

REVISIONS		
REV	DESCRIPTION	DATE
-	INITIAL REVISION	OCT 29, 2015
A	GENERAL NOTES 1-9 UPDATED TO REFERENCE SAE AIR4171A SPECIFICATION AND TO PROVIDE MORE SPECIFIC INSTRUCTIONS. PART MARKING POSITION ON ALL VIEWS UPDATED TO SPECIFY PART MARKING ON LONGER SIDE OF FOAM BLOCK.	NOV 06, 2015
B	UPDATED GN2, GN3 & GN9 WITH REVISED REFERENCES.	NOV 11, 2015
C	PART NUMBERS -11, -71 THRU -75, -79 THRU -83, -89, -93 AND -97 REMOVED. PART NUMBERS -99 THRU -263 ADDED.	DEC 15, 2015
D	DRAWING UPDATED ON SH42, SH44, SH89 & SH93	JAN 12, 2016
E	QTY FOR VARIANT -15, -33, -85 CHANGED TO 3, 1, 9 RESPECTIVELY ON SHEET 1.  MARKINGS ADDED TO THE FOAMS TO ASSIST INSTALLATION PROCESS.  PARTS UPDATED -9, -127, -129, -131, -143, -201, -243, -245, -247 AND -257 DUE TO CHANGES IN DESIGN.  ANGULAR AND LINEAR DIMENSIONS INTRODUCED IN ALL DRAWINGS.  GN8 AMENDED. GN10, GN11 & GN12 ADDED.	OCT 27, 2017

INDEX															
SHEET	REV	DESCRIPTION	NHA	SHEET	REV	DESCRIPTION	NHA	SHEET	REV	DESCRIPTION	NHA	SHEET	REV	DESCRIPTION	NHA
0	E	INDEX	-	32	E	DETAIL -61	-	64	E	DETAIL -143	-	96	E	DETAIL -207	-
1	E	PARTS LIST	-	33	E	DETAIL -63	-	65	E	DETAIL -145	-	97	E	DETAIL -209	-
2	E	NOTES	-	34	E	DETAIL -65	-	66	E	DETAIL -147	-	98	E	DETAIL -211	-
3	E	DETAIL -1	-	35	E	DETAIL -67	-	67	E	DETAIL -149	-	99	E	DETAIL -213	-
4	E	DETAIL -3	-	36	E	DETAIL -69	-	68	E	DETAIL -151	-	100	E	DETAIL -215	-
5	E	DETAIL -5	-	37	E	DETAIL -77	-	69	E	DETAIL -153	-	101	E	DETAIL -217	-
6	E	DETAIL -7	-	38	E	DETAIL -85	-	70	E	DETAIL -155	-	102	E	DETAIL -219	-
7	E	DETAIL -9	-	39	E	DETAIL -89	-	71	E	DETAIL -157	-	103	E	DETAIL -221	-
8	E	DETAIL -13	-	40	E	DETAIL -91	-	72	E	DETAIL -159	-	104	E	DETAIL -223	-
9	E	DETAIL -15	-	41	E	DETAIL -95	-	73	E	DETAIL -161	-	105	E	DETAIL -225	-
10	E	DETAIL -17	-	42	E	DETAIL -99	-	74	E	DETAIL -163	-	106	E	DETAIL -227	-
11	E	DETAIL -19	-	43	E	DETAIL -101	-	75	E	DETAIL -165	-	107	E	DETAIL -229	-
12	E	DETAIL -21	-	44	E	DETAIL -103	-	76	E	DETAIL -167	-	108	E	DETAIL -231	-
13	E	DETAIL -23	-	45	E	DETAIL -105	-	77	E	DETAIL -169	-	109	E	DETAIL -233	-
14	E	DETAIL -25	-	46	E	DETAIL -107	-	78	E	DETAIL -171	-	110	E	DETAIL -235	-
15	E	DETAIL -27	-	47	E	DETAIL -109	-	79	E	DETAIL -173	-	111	E	DETAIL -237	-
16	E	DETAIL -29	-	48	E	DETAIL -111	-	80	E	DETAIL -175	-	112	E	DETAIL -239	-
17	E	DETAIL -31	-	49	E	DETAIL -113	-	81	E	DETAIL -177	-	113	E	DETAIL -241	-
18	E	DETAIL -33	-	50	E	DETAIL -115	-	82	E	DETAIL -179	-	114	E	DETAIL -243	-
19	E	DETAIL -35	-	51	E	DETAIL -117	-	83	E	DETAIL -181	-	115	E	DETAIL -245	-
20	E	DETAIL -37	-	52	E	DETAIL -119	-	84	E	DETAIL -183	-	116	E	DETAIL -247	-
21	E	DETAIL -39	-	53	E	DETAIL -121	-	85	E	DETAIL -185	-	117	E	DETAIL -249	-
22	E	DETAIL -41	-	54	E	DETAIL -123	-	86	E	DETAIL -187	-	118	E	DETAIL -251	-
23	E	DETAIL -43	-	55	E	DETAIL -125	-	87	E	DETAIL -189	-	119	E	DETAIL -253	-
24	E	DETAIL -45	-	56	E	DETAIL -127	-	88	E	DETAIL -191	-	120	E	DETAIL -255	-
25	E	DETAIL -47	-	57	E	DETAIL -129	-	89	E	DETAIL -193	-	121	E	DETAIL -257	-
26	E	DETAIL -49	-	58	E	DETAIL -131	-	90	E	DETAIL -195	-	122	E	DETAIL -259	-
27	E	DETAIL -51	-	59	E	DETAIL -133	-	91	E	DETAIL -197	-	123	E	DETAIL -261	-
28	E	DETAIL -53	-	60	E	DETAIL -135	-	92	E	DETAIL -199	-	124	E	DETAIL -263	-
29	E	DETAIL -55	-	61	E	DETAIL -137	-	93	E	DETAIL -201	-				
30	E	DETAIL -57	-	62	E	DETAIL -139	-	94	E	DETAIL -203	-				
31	E	DETAIL -59	-	63	E	DETAIL -141	-	95	E	DETAIL -205	-				

UNLESS OTHERWISE SPECIFIED DIMENSIONS ARE IN INCHES [MM] TOLERANCES ARE:

.X ±.25 ±[6.35]	.XX ±.25 ±[6.35]	.XXX ±.25 ±[6.35]	ANGLE ±2°
-----------------------	------------------------	-------------------------	--------------

THIRD ANGLE PROJECTION

DO NOT SCALE DRAWING

THE INFORMATION CONTAINED HEREIN IS PROPRIETARY TO COMTECH AVIATION SERVICES AND SHALL NOT BE REPRODUCED OR DISCLOSED IN WHOLE OR IN PART OR USED FOR ANY DESIGN OR MANUFACTURE EXCEPT WHEN SUCH USER POSSESSES DIRECT, WRITTEN AUTHORIZATION FROM COMTECH AVIATION SERVICES.

CAD DRAWING NOT TO BE REVISED BY HAND

APPROVALS	DATE	APPROVALS	DATE
DRAWN A. CHONG 	OCT 27 2017	STRUCTURES N/A	
CHECKED F. WAHAB 	OCT 27 2017	SYSTEMS N/A	
INTERIORS N/A		APPROVED R. BLASCO 	OCT 27 2017

121 ALHAMBRA PLAZA  
SUITE 1700, CORAL GABLES  
FL 33134 USA  
WWW.AERSALE.COM

DRAWING TITLE  
**FOAM BLOCK**

SIZE **A3** DRAWING NUMBER **AES-D0001** REV **E**

SCALE **NONE** DATASET **AES-D0001E** SHEET **0** OF **124**



**GENERAL NOTES:**

- GN1 FOAM TO BE IN ACCORDANCE WITH MIL SPEC MIL-PRF-87260B, CLASS 2 - GRADE 1 (COARSE PORE).
- GN2 IF BULK FOAM MATERIAL IS PROVIDED, THE FOAM SHOULD BE RECEIVED IN A MULTIPACKED CONFIGURATION FROM THE SUPPLIER TO ENSURE NO CONTAMINATION. MULTIPLE BUNS MAY BE CONTAINED IN A PACKAGE BUT EACH BUN MUST BE INDIVIDUALLY PACKED. UPON RECEIPT OF THE PACKAGES, CHECK THE PACKAGING FOR DAMAGE. IF DAMAGE IS PRESENT, CHECK THE FOAM FOR DAMAGE / CONTAMINATION. REFER TO SAE SPECIFICATION AIR4170 REV. A, PARAGRAPH 3.6.1 FOR INFORMATION ON PACKAGING DAMAGE.
- GN3 STORAGE OF THE FOAM MUST BE IN UNDAMAGED PACKAGING AWAY FROM ULTRAVIOLET LIGHT AND IN AN ENVIRONMENT WHERE CONTAMINATION IS AVOIDED. REFER TO SAE SPECIFICATION AIR4170 REV. A, PARAGRAPH 3.6.1 FOR INFORMATION ON PACKAGING DAMAGE.
- GN4 THE FABRICATOR'S MANUFACTURING AREA SHOULD MEET REQUIRED CLEANLINESS TO CONTROL CONTAMINANTS THAT WOULD ADVERSELY AFFECT THE MATERIAL OR ITS FUNCTIONALITY. IT IS EXTREMELY IMPORTANT TO CONTROL SUCH CONTAMINANTS AS FOREIGN PARTICLES, METAL PARTICLES, DUST, SUNLIGHT, WATER, WATER VAPOR STEAM, HARMFUL LIQUIDS, AND HARMFUL GASES. MANUFACTURING MANAGEMENT SHOULD ADDRESS THE REQUIREMENTS IDENTIFIED IN SAE SPECIFICATION AIR4170 REV. A, PARAGRAPH 3.6.3.
- GN5 CUTTING AND SHAPING OF INDIVIDUAL FOAM COMPONENTS CAN BE ACCOMPLISHED BY THE FOLLOWING METHODS:  
 A. HOT WIRE CUTTING (SEE SAE SPECIFICATION AIR4170 REV. A, PARAGRAPH 3.6.3.1).  
 B. MECHANICAL BLADE TYPE CUTTING (BAND SAW, ELECTRIC KNIFE) (SEE SAE SPECIFICATION AIR4170 REV. A, PARAGRAPH 3.6.3.2)  
 C. SPECIALLY DESIGNED / MANUFACTURED SMOOTH BLADE TYPE CUTTING TOOLS.
- GN6 HANDLING OF RETICULATED POLYURETHANE FOAM SHOULD NOT RESULT IN THE TRANSFER OF FOREIGN MATERIALS ONTO, OR INTO THE FOAM STRUCTURE. THE CLOTHING WORN BY PERSONNEL FABRICATING THE COMPONENTS/KITS SHOULD NOT BE A SOURCE OF CONTAMINATION TO THE FUEL CELL BAFFLE MATERIAL. REFER TO SAE SPECIFICATION AIR4170 REV. A, PARAGRAPH 3.6.3.3 FOR FURTHER DETAILS.
- GN7 UPON COMPLETION OF FABRICATION AND BEFORE FINAL INSPECTION, COMPONENTS WILL REQUIRE A FINAL CLEANING TO REMOVE ANY FOAM DEBRIS OR CONTAMINANTS LEFT FROM THE FABRICATING PROCESS. ALL COMPONENTS MUST BE BOUNCED AND THOROUGHLY SCRUBBED ON A SCREEN OR HARDWARE CLOTH TO REMOVE LOOSE PARTICLES OF FOAM AND/OR BEADS OF MELTED FOAM AS A RESULT OF FABRICATION. REFER TO SAE SPECIFICATION AIR4170 REV. A, PARAGRAPH 3.6.3.4 FOR INFORMATION ON CLEANING.
- GN8 COMPONENT IDENTIFICATION NUMBERS/LETTERS MUST BE APPLIED TO EACH COMPONENT AFTER FABRICATION IN THE POSITION SHOWN ON THE DRAWINGS. REFER GN10 & GN11 FOR ADDITIONAL DETAILS ON MARKING. PART MARKING MUST ALSO INCLUDE DATE OF FABRICATION. INK TO BE IN ACCORDANCE WITH FEDERAL SPECIFICATION A-A-208() IN A CONTRASTING COLOUR.
- GN9 IMMEDIATELY UPON COMPLETING THE CLEANING AND IDENTIFICATION MARKING OF A COMPONENT IT SHALL BE PACKAGED TO PREVENT POSSIBLE CONTAMINATION. MINIMUM LEVEL OF PROTECTION WHEN PACKAGING SHOULD BE AS FOLLOWS:  
 - EACH INDIVIDUAL COMPONENT SHALL BE WRAPPED IN A 4-MIL, BLACK POLYETHYLENE FILM, TAPED OR SEALED CLOSED, AND PROPERLY IDENTIFIED  
 - INDIVIDUALLY WRAPPED COMPONENTS SHALL THEN BE MULTIPACKED INTO COMMERCIAL GRADE CORRUGATED CARTONS, AND SEALED CLOSED WITH TAPE. MARKINGS ON THE EXTERIOR CARTON SHALL IDENTIFY THE CONTENTS. THE PACKAGED COMPONENTS/KITS SHALL BE STORED IN AN AREA TO PROTECT THEM FROM THE OUTDOOR ENVIRONMENT.
- REFER TO SAE SPECIFICATION AIR4170 REV. A, PARAGRAPH 3.6.6 FOR INFORMATION ON PACKAGING AND STORAGE
- GN10 MARKINGS ON THE FOAM REPRESENT THE FOLLOWING:  
 'F' - FACE OF FOAM FACING FORWARD OF THE AIRCRAFT  
 - 'THIS END UP' ARROW
- 
- GN11 PART NUMBER AND ALL MARKINGS PER GN10 TO BE MARKED IN POSITION SHOWN ON DRAWING. THE TEXT HEIGHT OF FACE OF FOAM ('F') AND ARROW IS 3 INCHES. THE TEXT HEIGHT OF PART NUMBER IS 2.5 INCHES. CHANGE TEXT HEIGHT OF MARKINGS AS REQUIRED. HOWEVER, IF CONSTRAINED FOR SPACE PART NUMBER CAN BE MARKED ON ADJACENT FACES. ARROWS NEEDS TO BE CONSPICUOUS.
- GN12 PAGE 0 CONTAINS REV BLOCK, DOC NAME/REV/DATE/NUMBER, TOLERANCES, SIGNATURES AND INDEX.

NOTE: ALL VIEWS TAKEN AS TRUE VIEWS PARALLEL TO SURFACE OF PART

	DRAWING NUMBER				AES-D0001
	SIZE	SCALE	SHEET	OF	REVISION
A3	NONE	2	124	E	

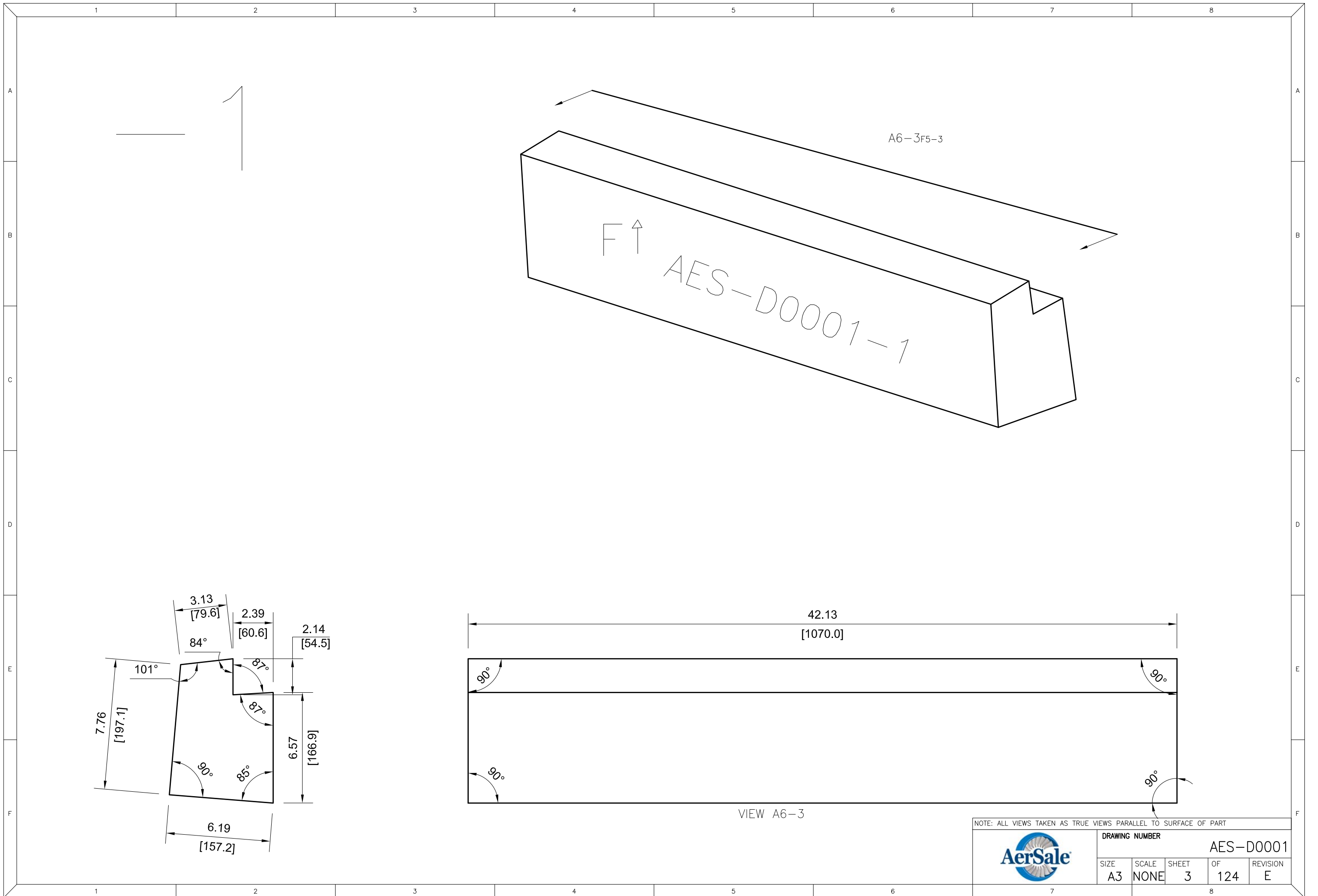

— 3

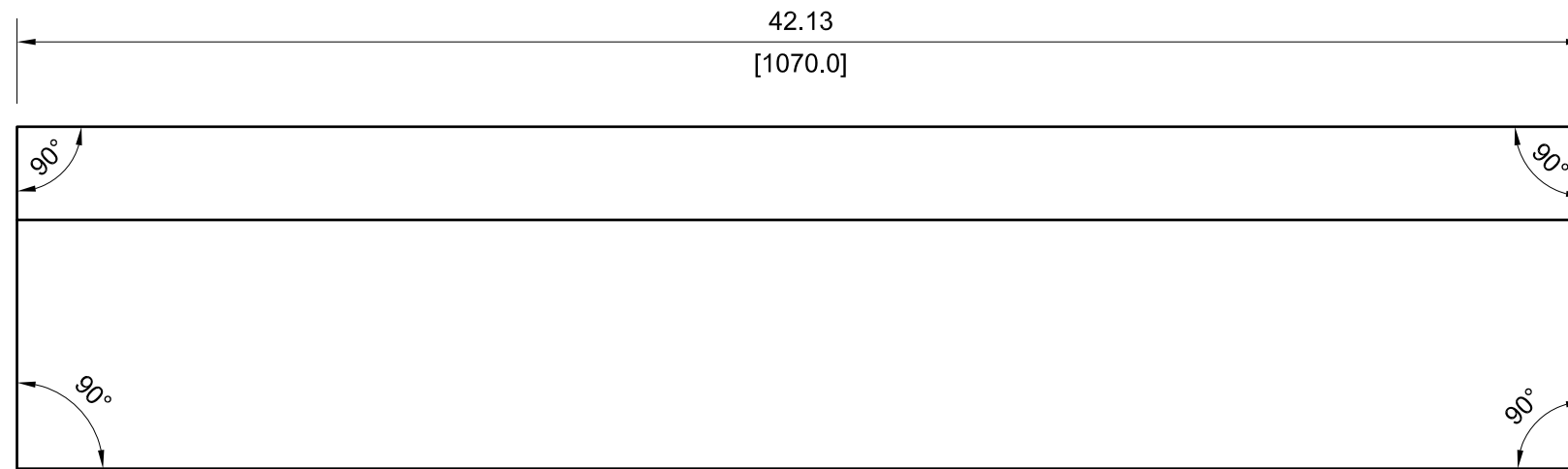
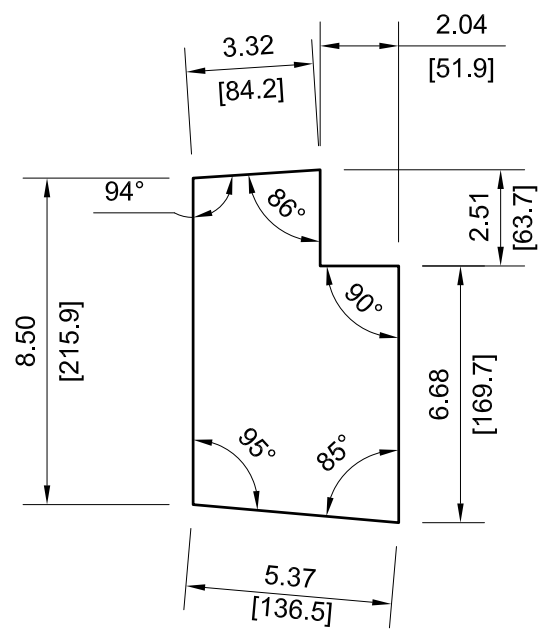
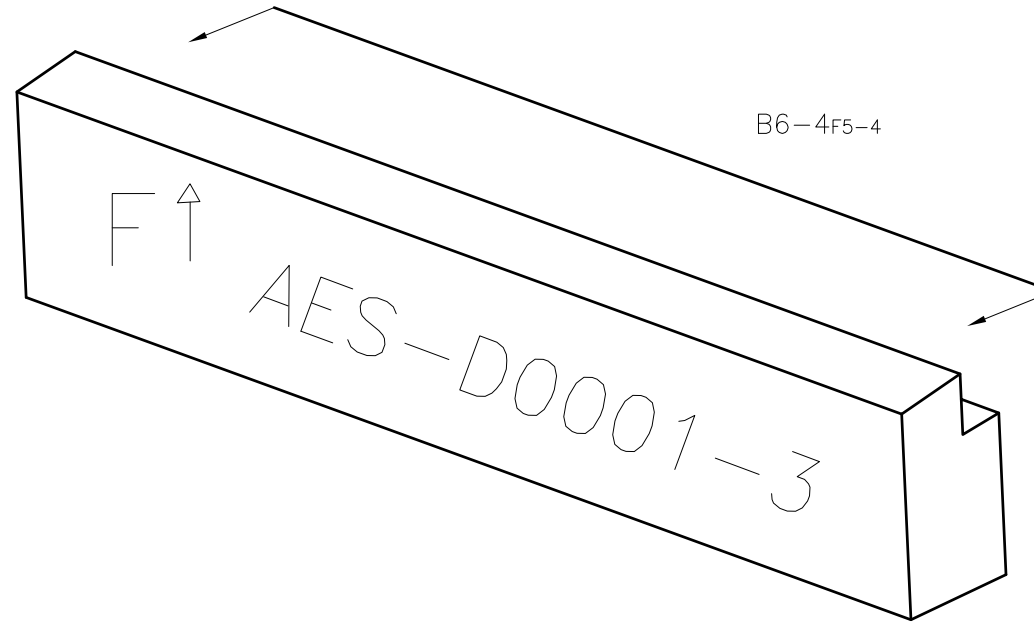

VIEW B6-4

NOTE: ALL VIEWS TAKEN AS TRUE VIEWS PARALLEL TO SURFACE OF PART



DRAWING NUMBER				
AES-D0001				
SIZE	SCALE	SHEET	OF	REVISION
A3	NONE	4	124	E

1 2 3 4 5 6 7 8

A  
B  
C  
D  
E  
F

5

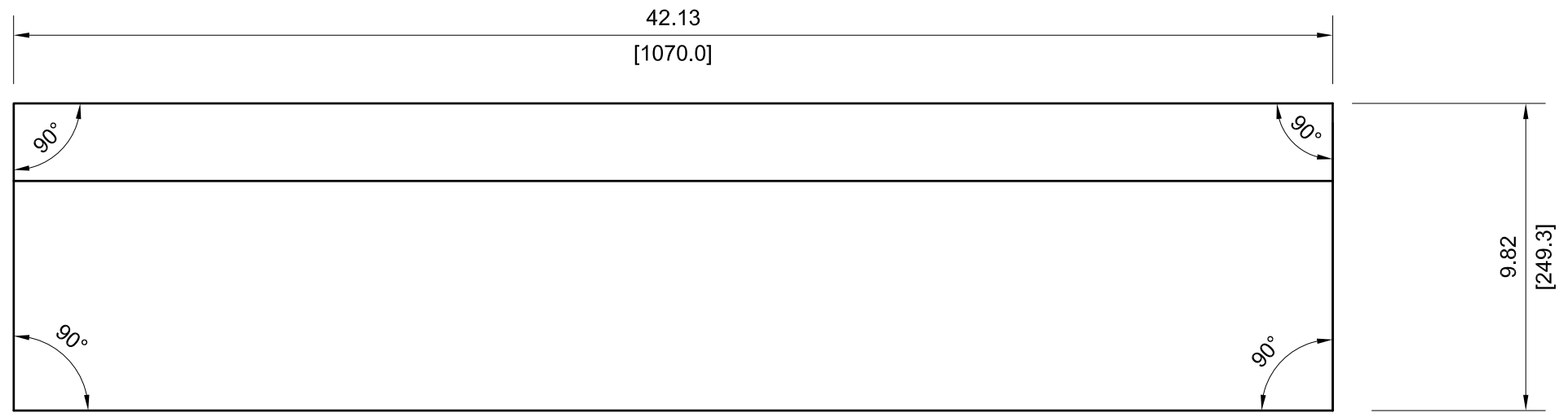
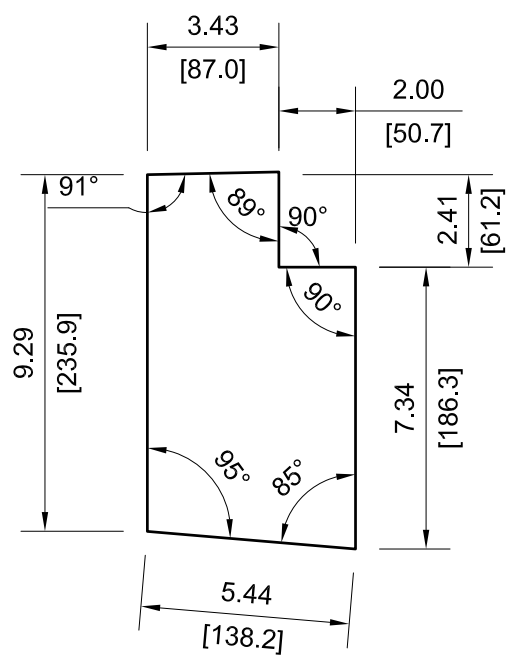
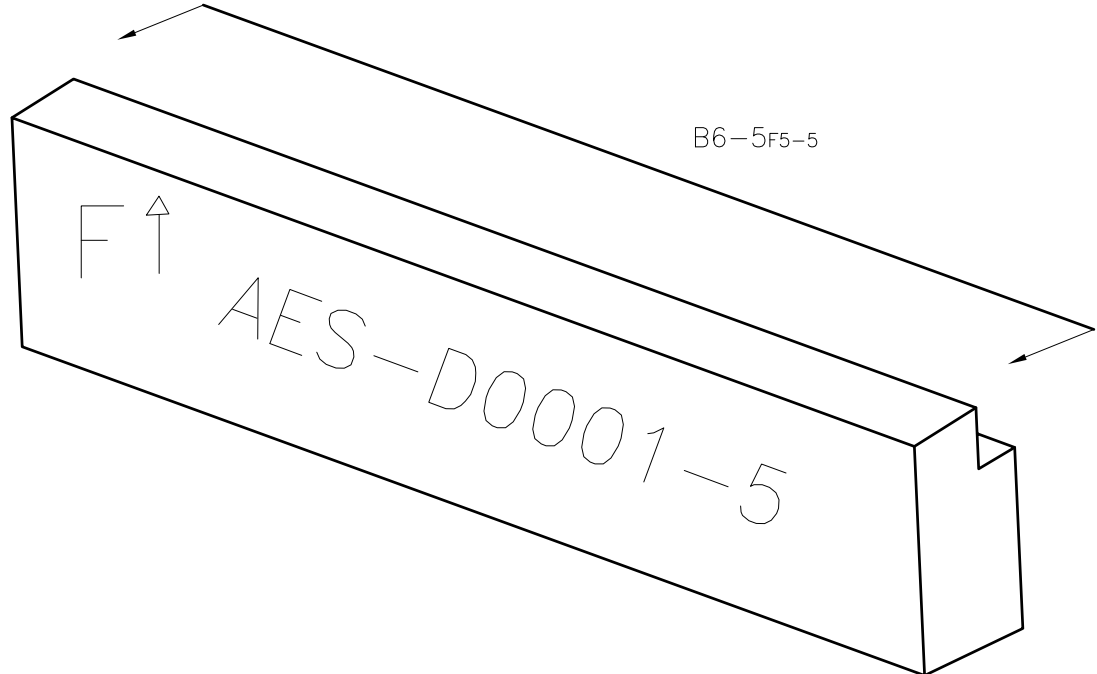

VIEW B6-5

NOTE: ALL VIEWS TAKEN AS TRUE VIEWS PARALLEL TO SURFACE OF PART

		DRAWING NUMBER			
		AES-D0001			
SIZE	SCALE	SHEET	OF	REVISION	
A3	NONE	5	124	E	

1 2 3 4 5 6 7 8

1 2 3 4 5 6 7 8

A

A

B

B

C

C

D

D

E

E

F

F

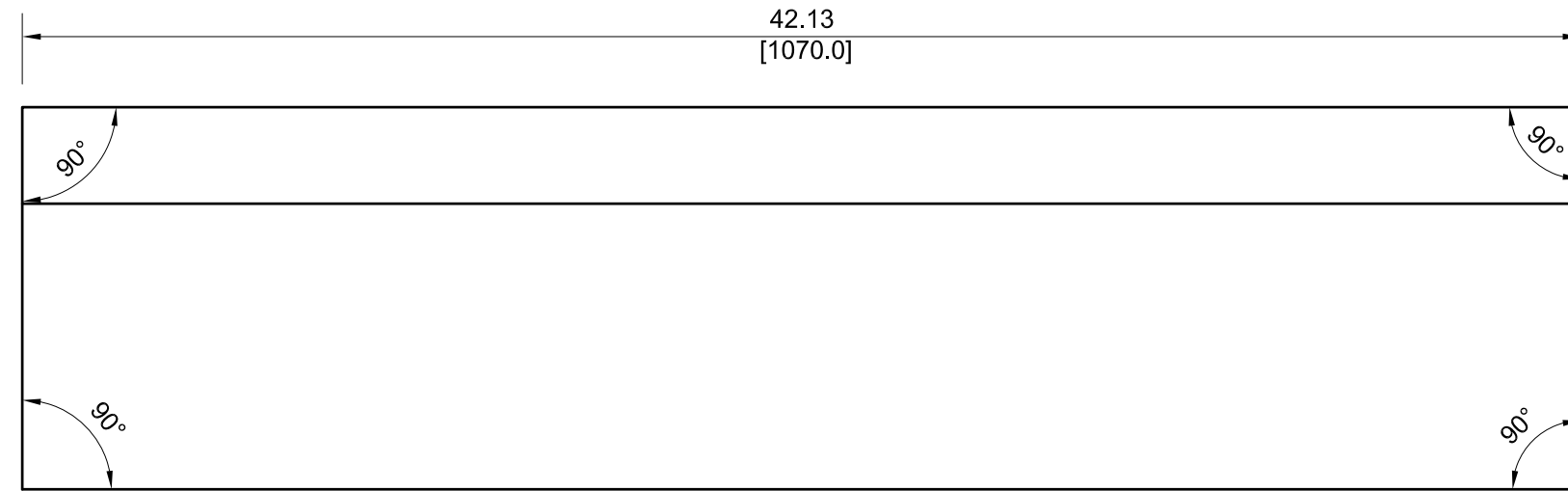
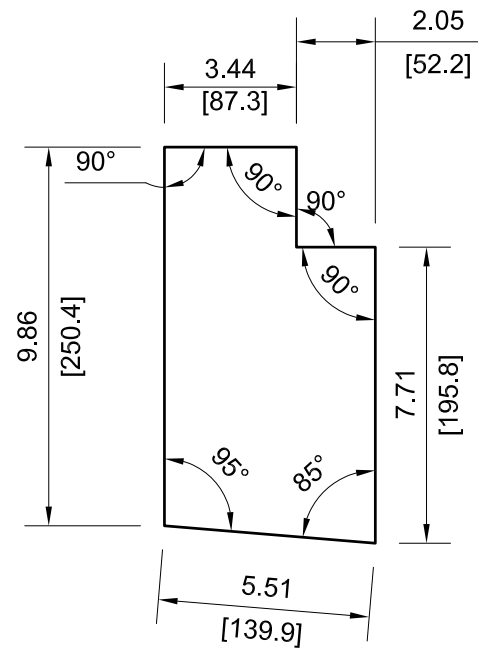
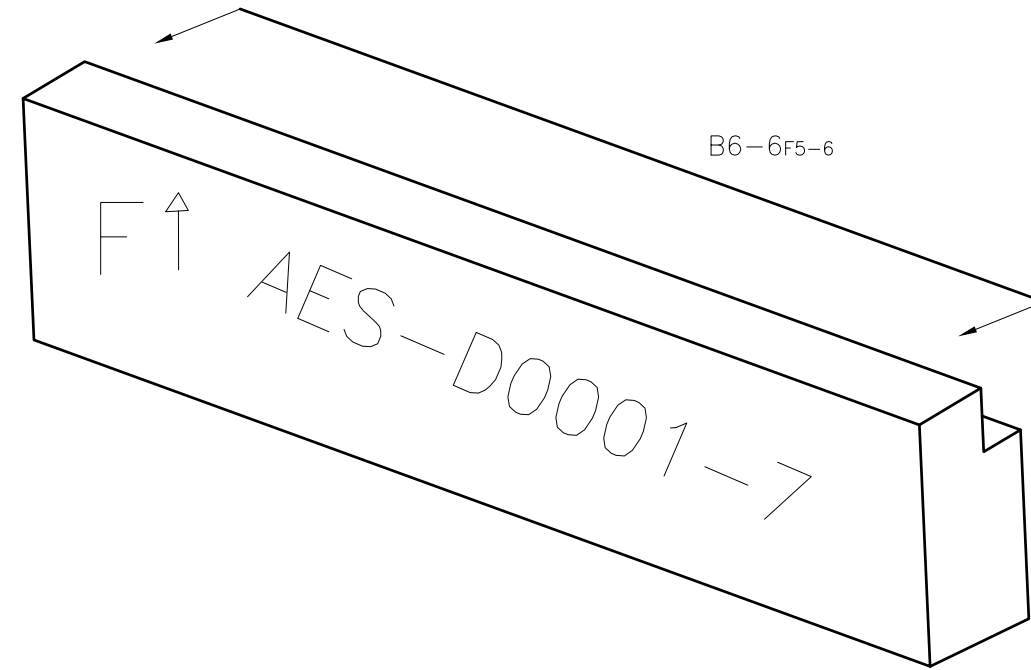
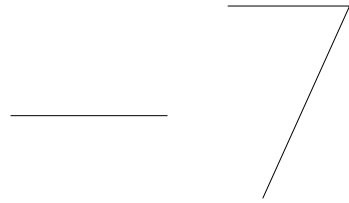

VIEW B6-6

NOTE: ALL VIEWS TAKEN AS TRUE VIEWS PARALLEL TO SURFACE OF PART



DRAWING NUMBER					AES-D0001	
SIZE	SCALE	SHEET	OF	REVISION		
A3	NONE	6	124	E		

1 2 3 4 5 6 7 8

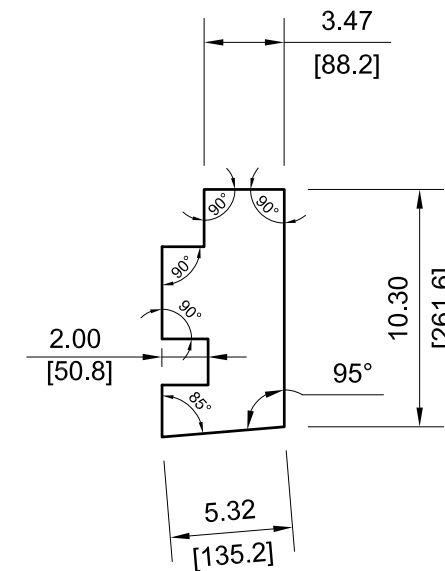
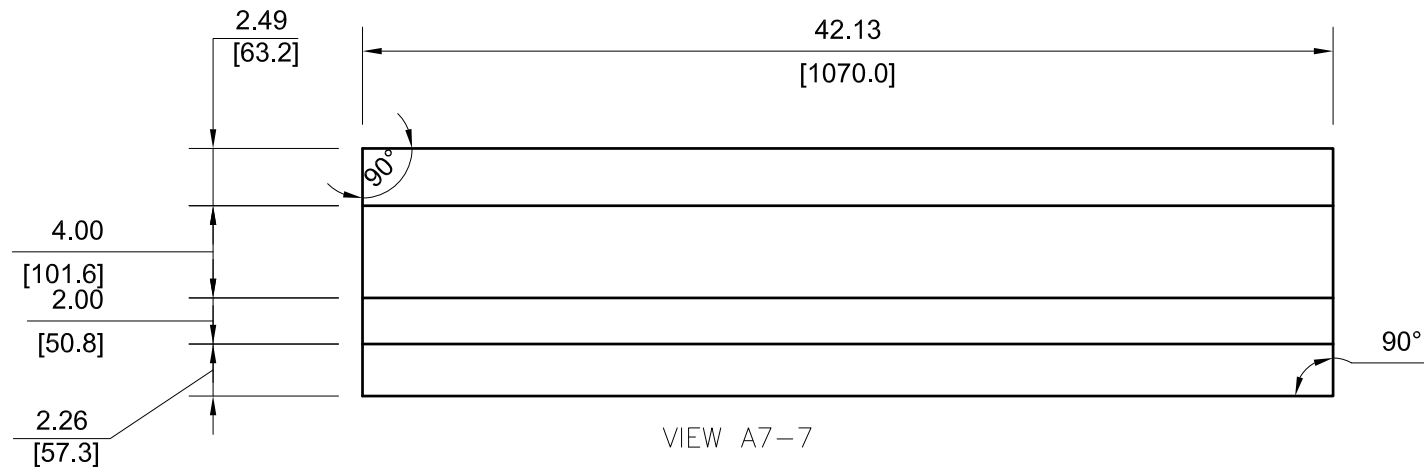
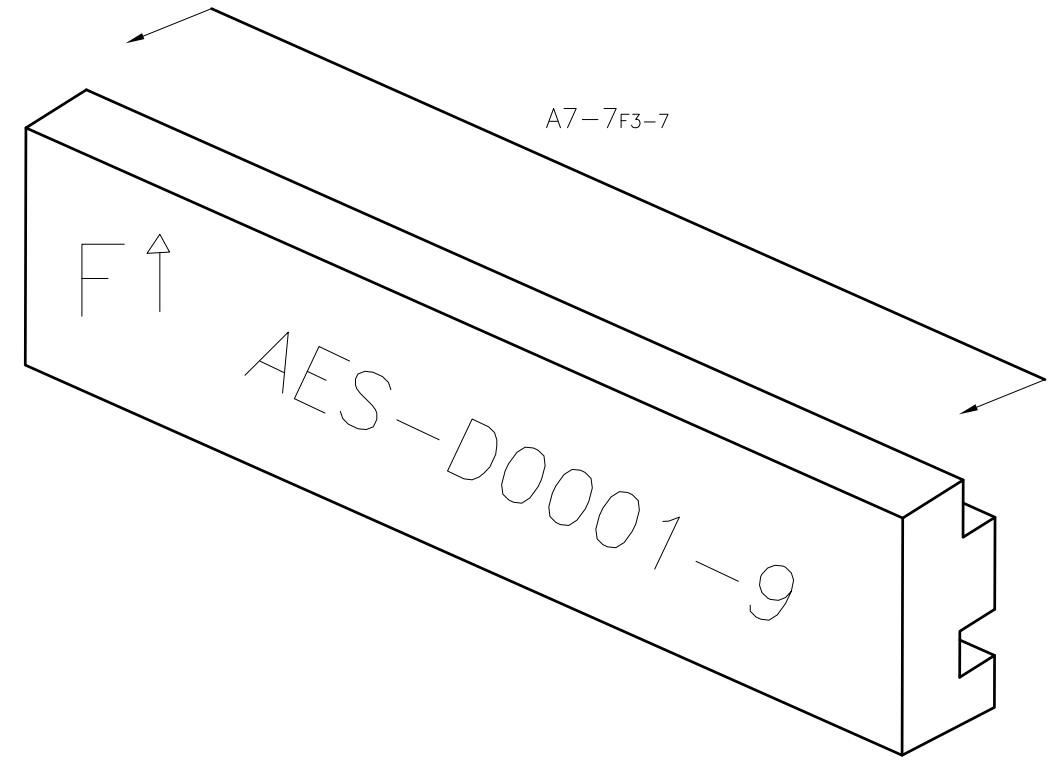
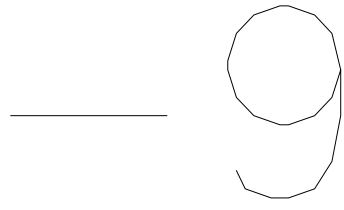

NOTE: ALL VIEWS TAKEN AS TRUE VIEWS PARALLEL TO SURFACE OF PART

		DRAWING NUMBER			
		AES-D0001			
SIZE	SCALE	SHEET	OF	REVISION	
A3	NONE	7	124	E	

— 13

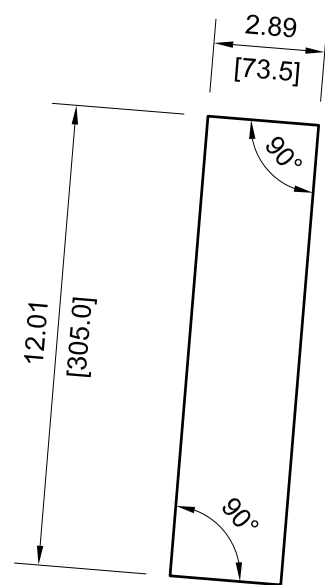
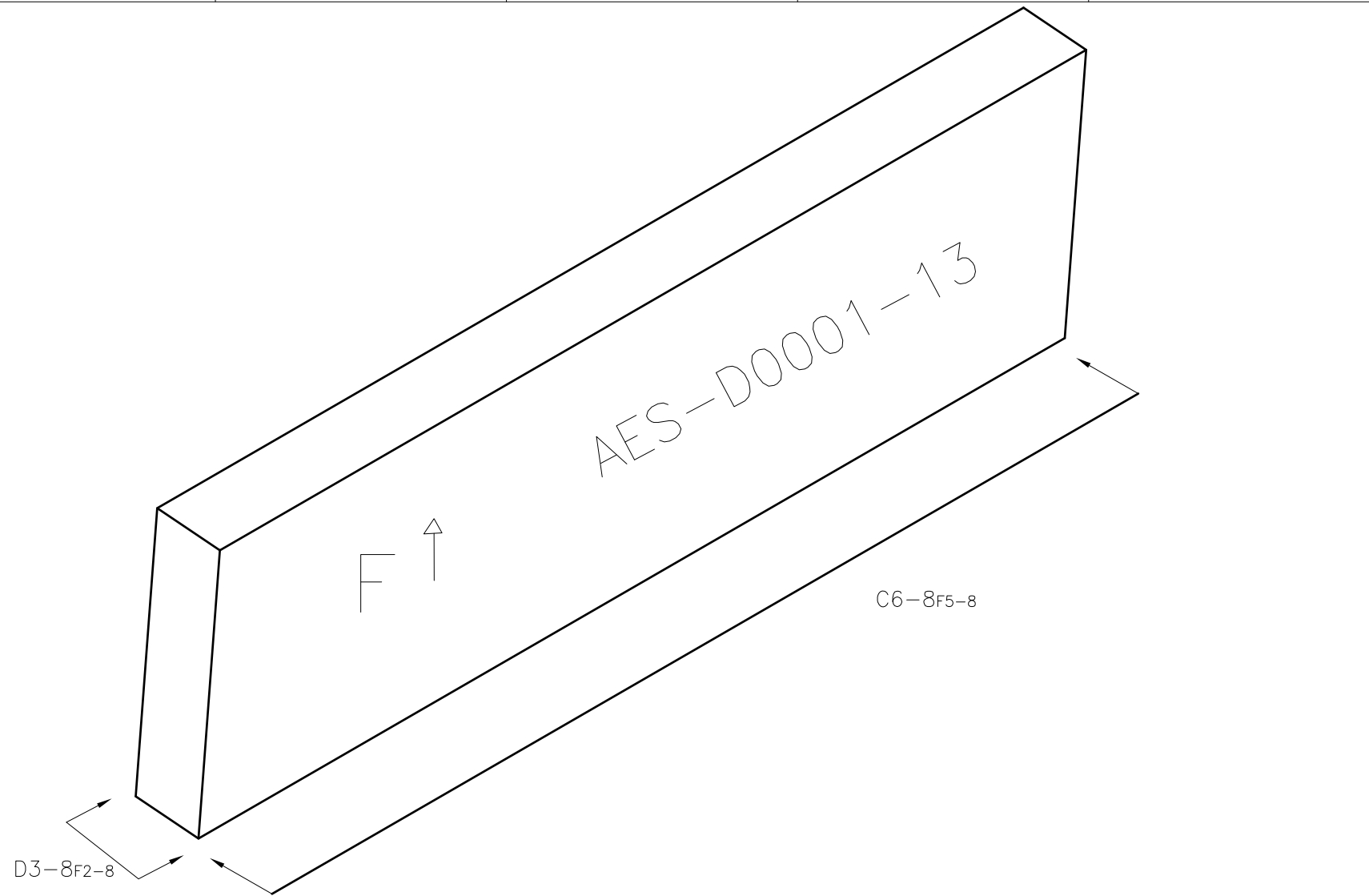

VIEW D3-8

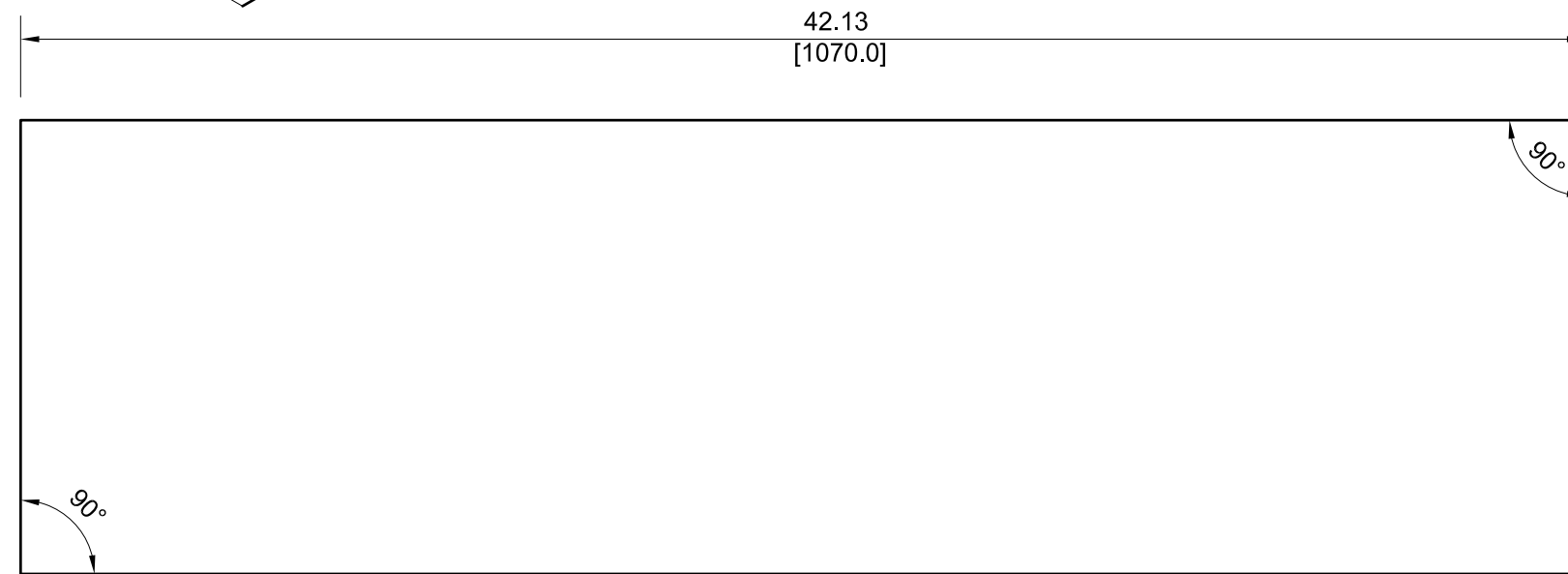

VIEW C6-8

NOTE: ALL VIEWS TAKEN AS TRUE VIEWS PARALLEL TO SURFACE OF PART



DRAWING NUMBER					AES-D0001		
SIZE	SCALE	SHEET	OF	REVISION			
A3	NONE	8	124	E			

15

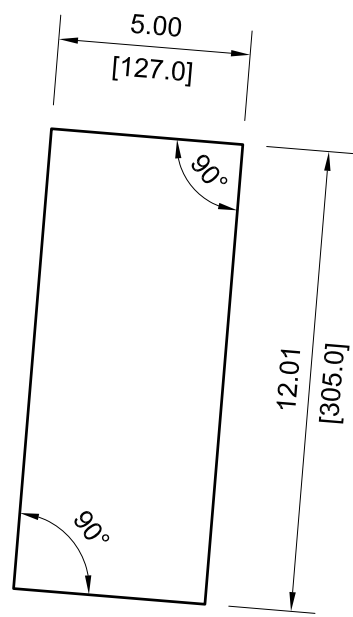
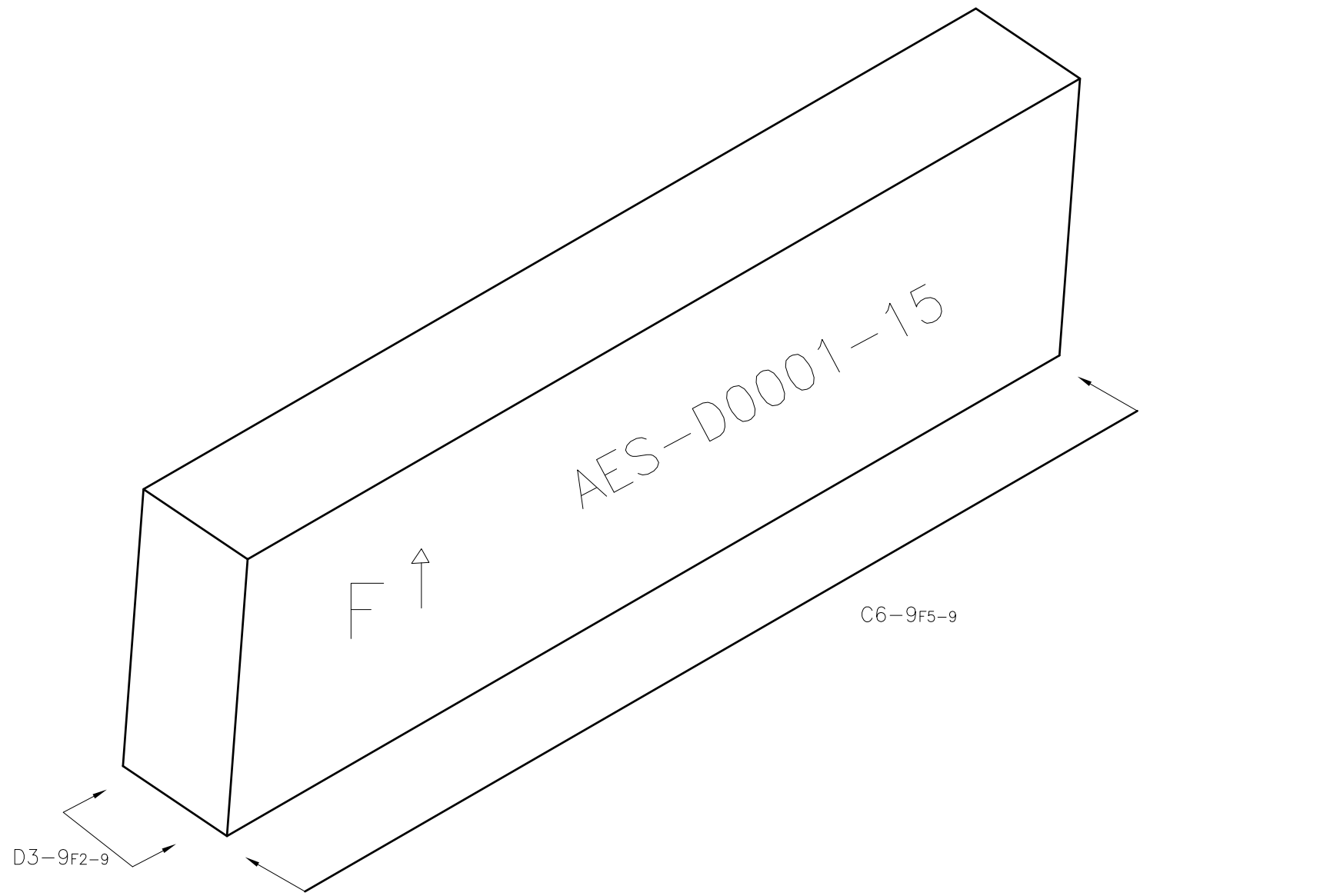

VIEW D3-9

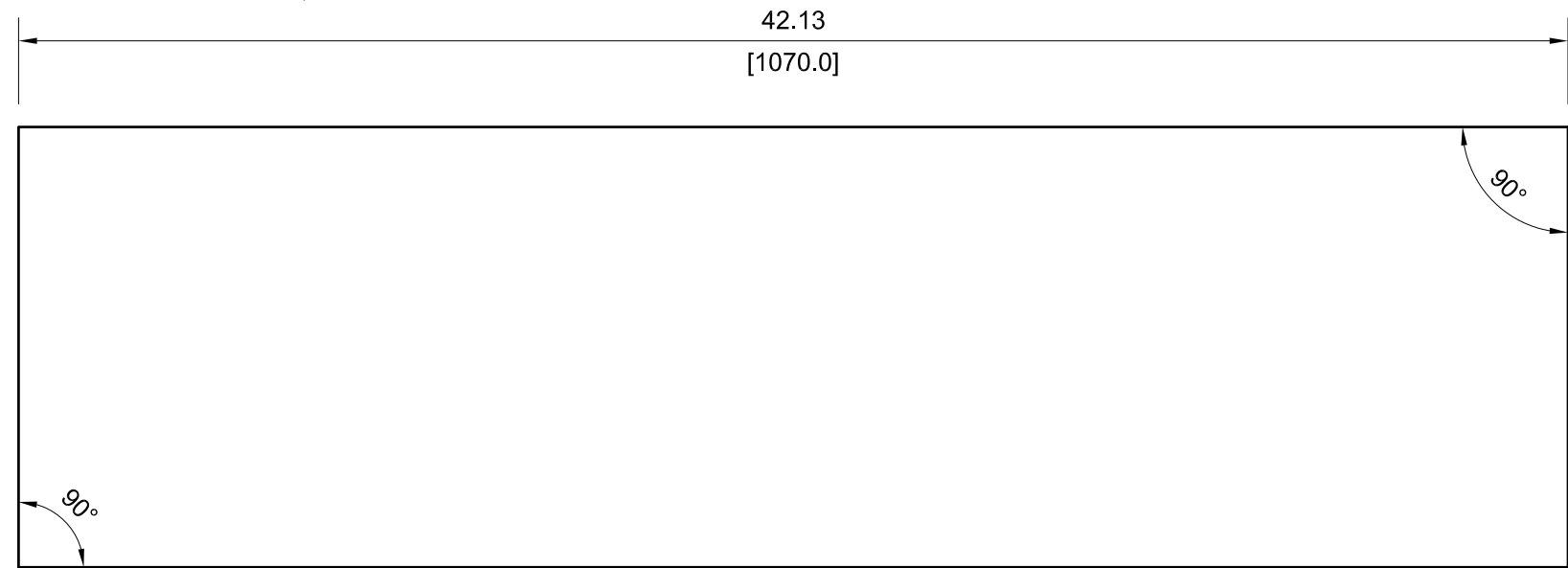

VIEW C6-9

NOTE: ALL VIEWS TAKEN AS TRUE VIEWS PARALLEL TO SURFACE OF PART



DRAWING NUMBER				
AES-D0001				
SIZE	SCALE	SHEET	OF	REVISION
A3	NONE	9	124	E

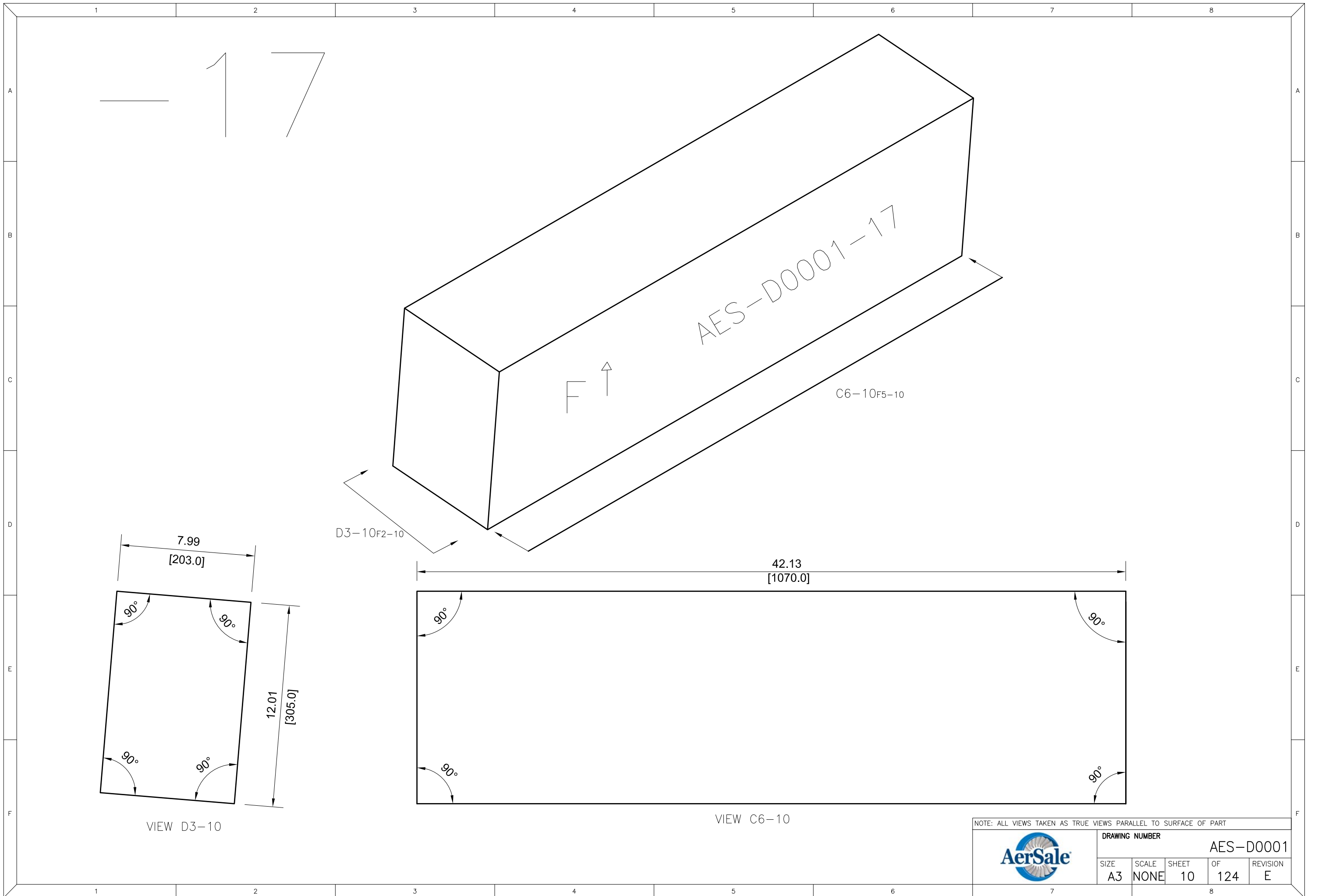

17

AES-D0001-17

F ↑

C6-10F5-10

D3-10F2-10

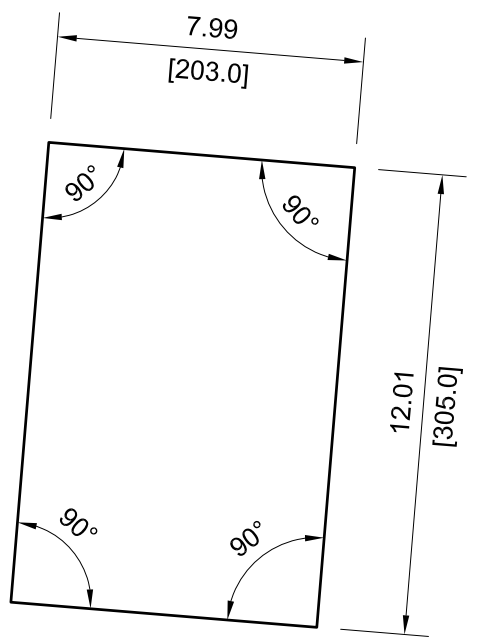

VIEW D3-10

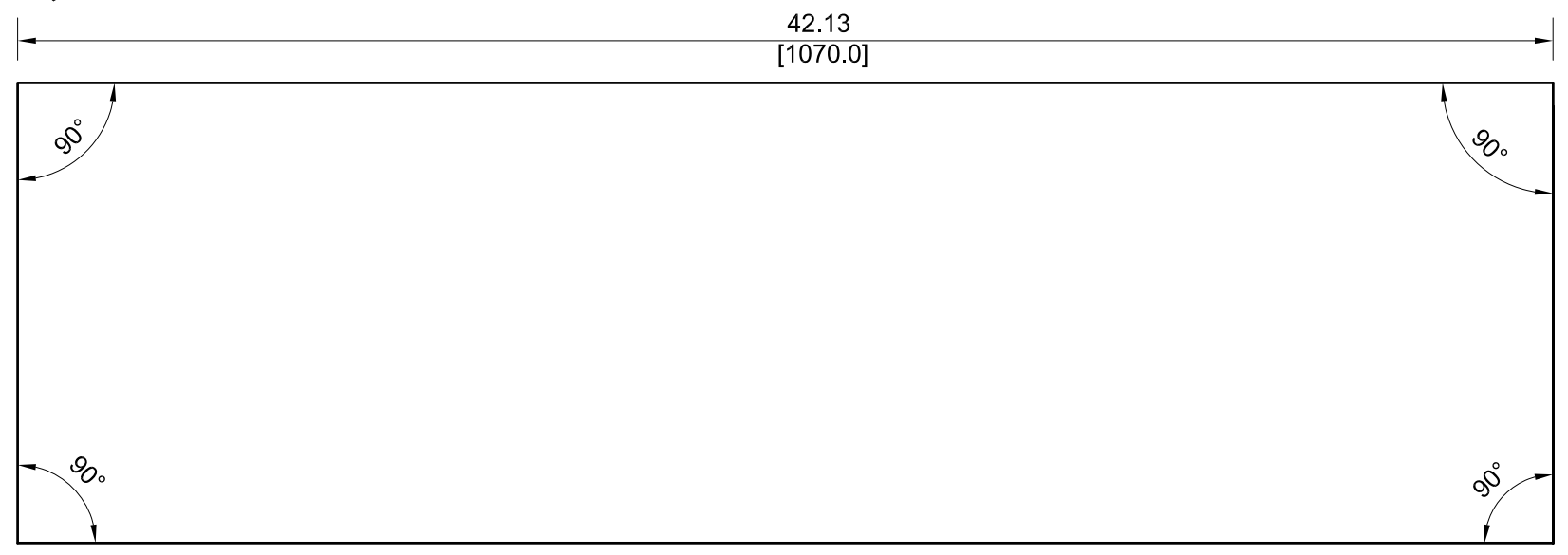

VIEW C6-10

NOTE: ALL VIEWS TAKEN AS TRUE VIEWS PARALLEL TO SURFACE OF PART

		DRAWING NUMBER			
		AES-D0001			
SIZE	SCALE	SHEET	OF	REVISION	
A3	NONE	10	124	E	

1 2 3 4 5 6 7 8

A

— 19

B

C

D

E

F

A

B

C

D

E

F

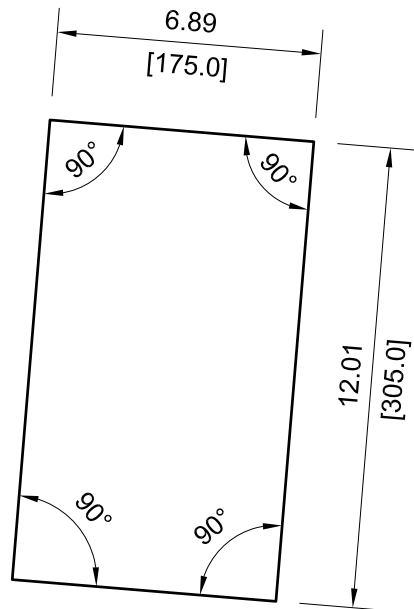
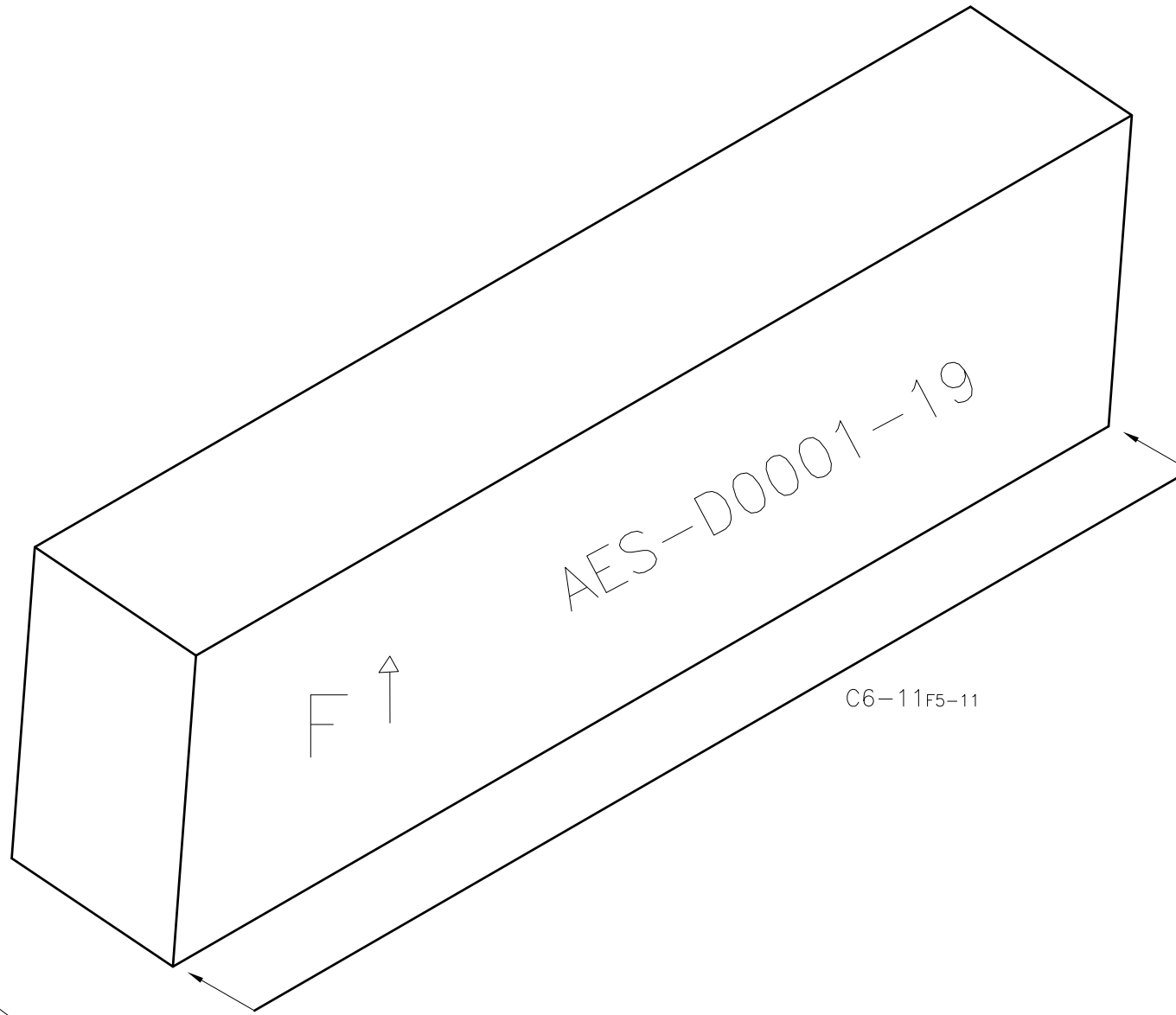

VIEW D3-11

D3-11F2-11

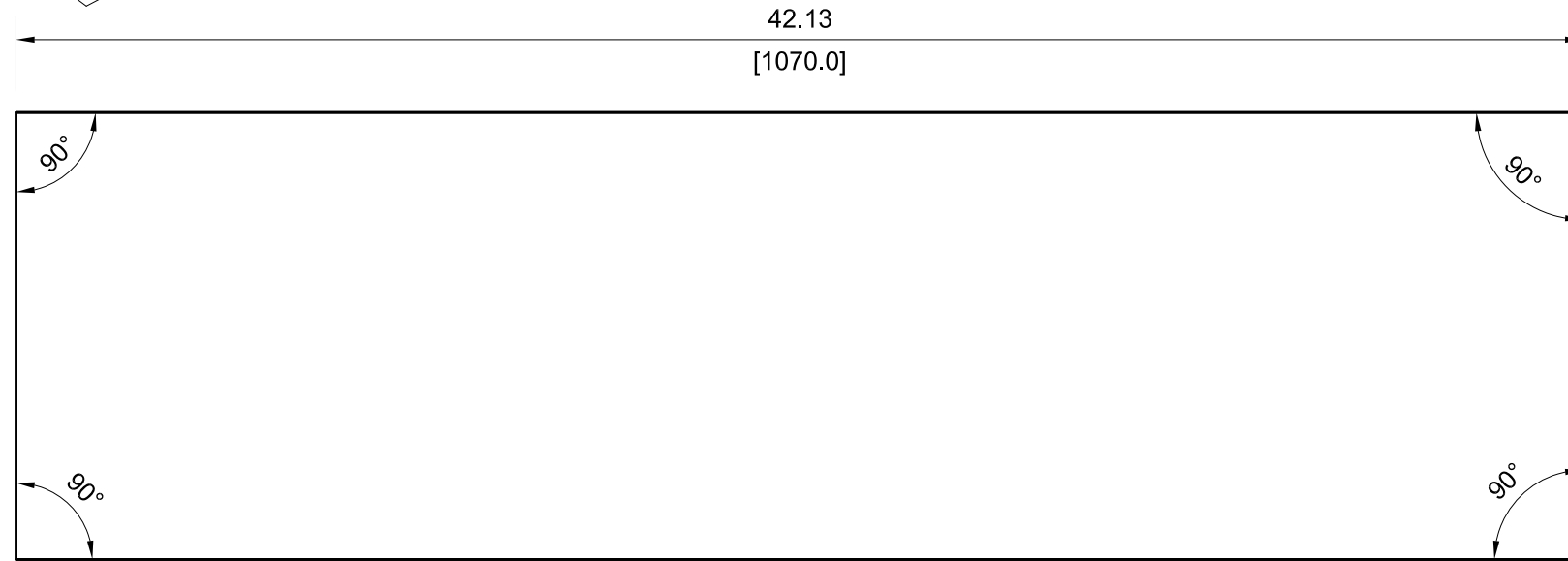

VIEW C6-11

NOTE: ALL VIEWS TAKEN AS TRUE VIEWS PARALLEL TO SURFACE OF PART



DRAWING NUMBER					AES-D0001	
SIZE	SCALE	SHEET	OF	REVISION		
A3	NONE	11	124	E		

1 2 3 4 5 6 7 8

1 2 3 4 5 6 7 8

A  
B  
C  
D  
E  
F

— 21

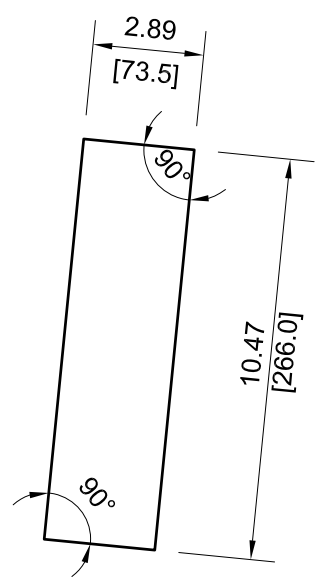
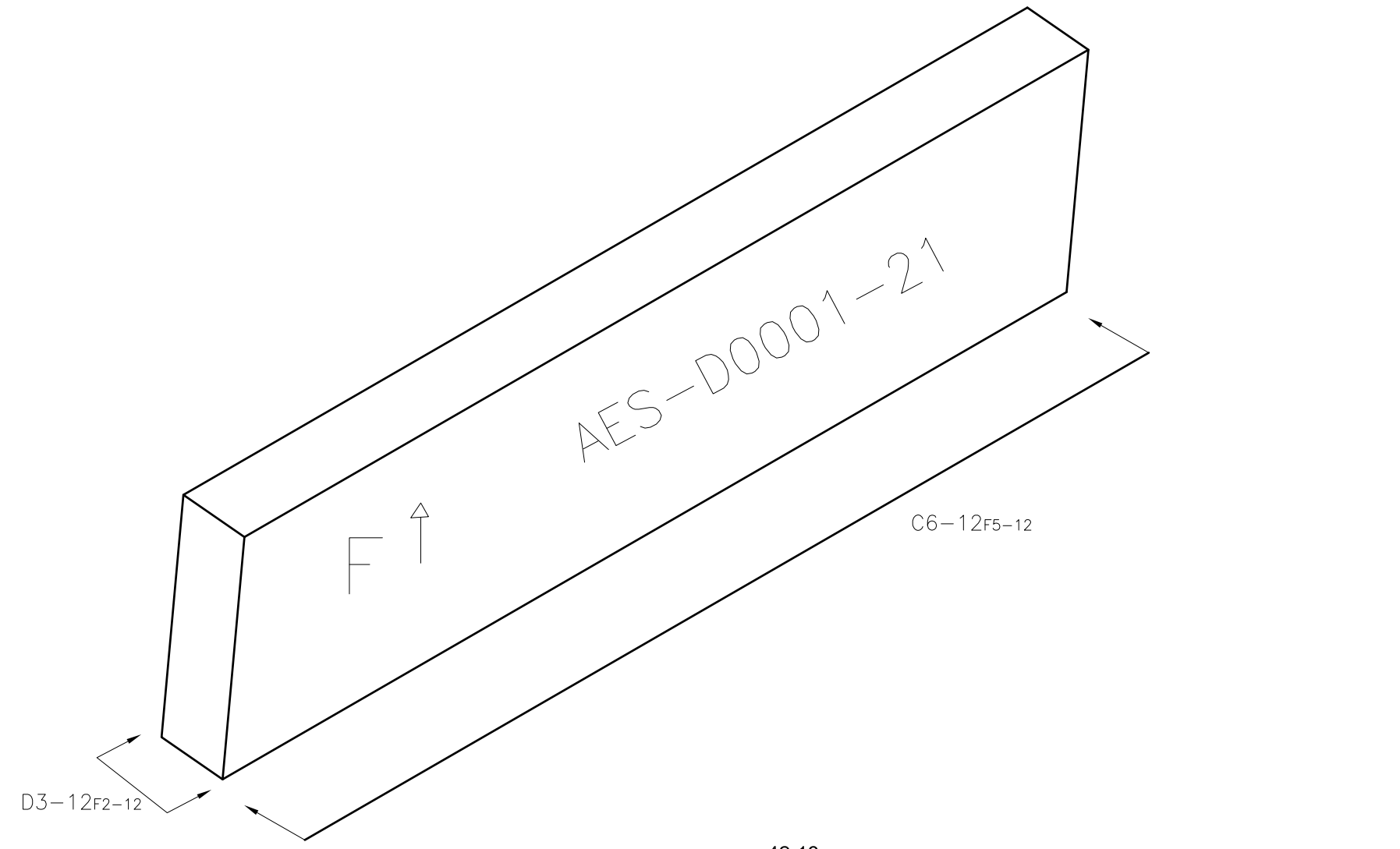

VIEW D3-12

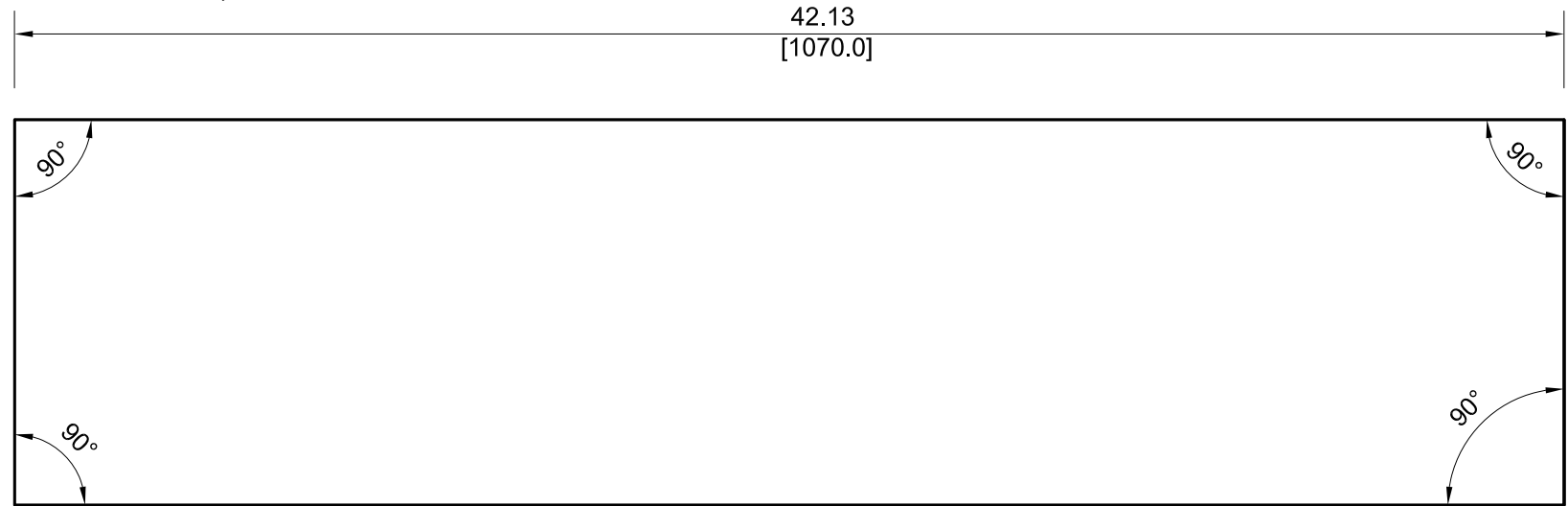

VIEW C6-12

NOTE: ALL VIEWS TAKEN AS TRUE VIEWS PARALLEL TO SURFACE OF PART



DRAWING NUMBER					AES-D0001	
SIZE	SCALE	SHEET	OF	REVISION		
A3	NONE	12	124	E		

1 2 3 4 5 6 7 8

— 23

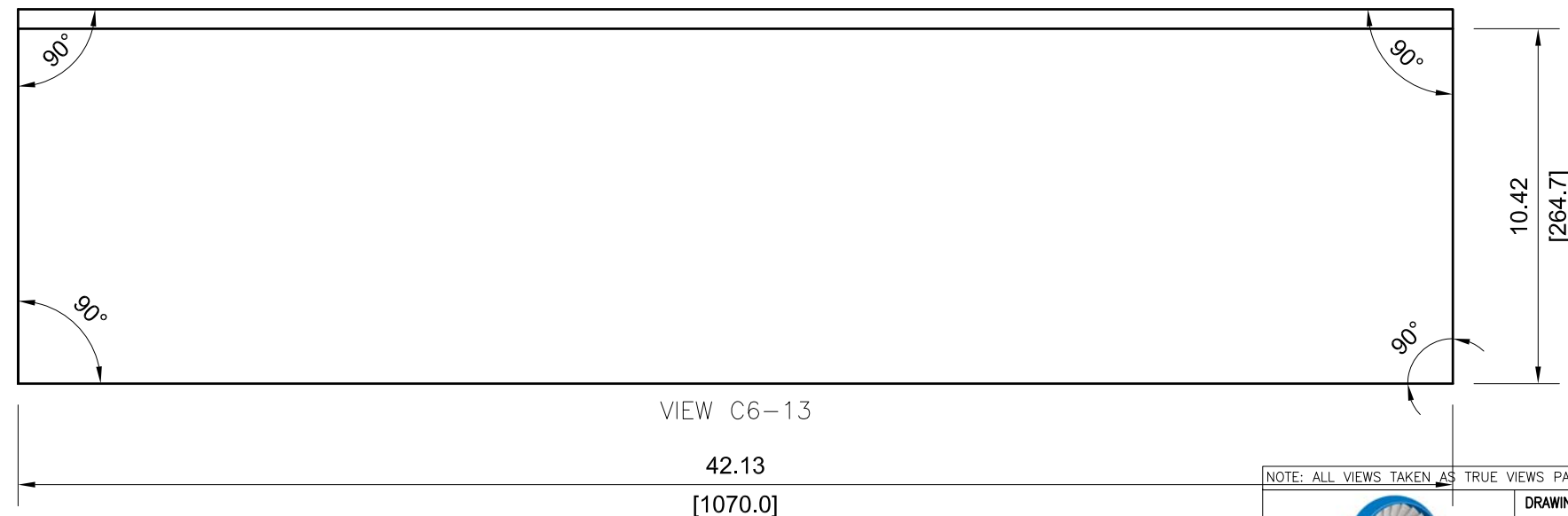
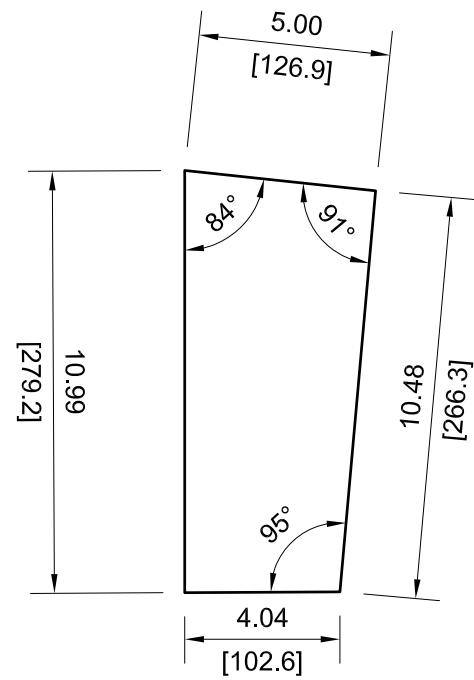
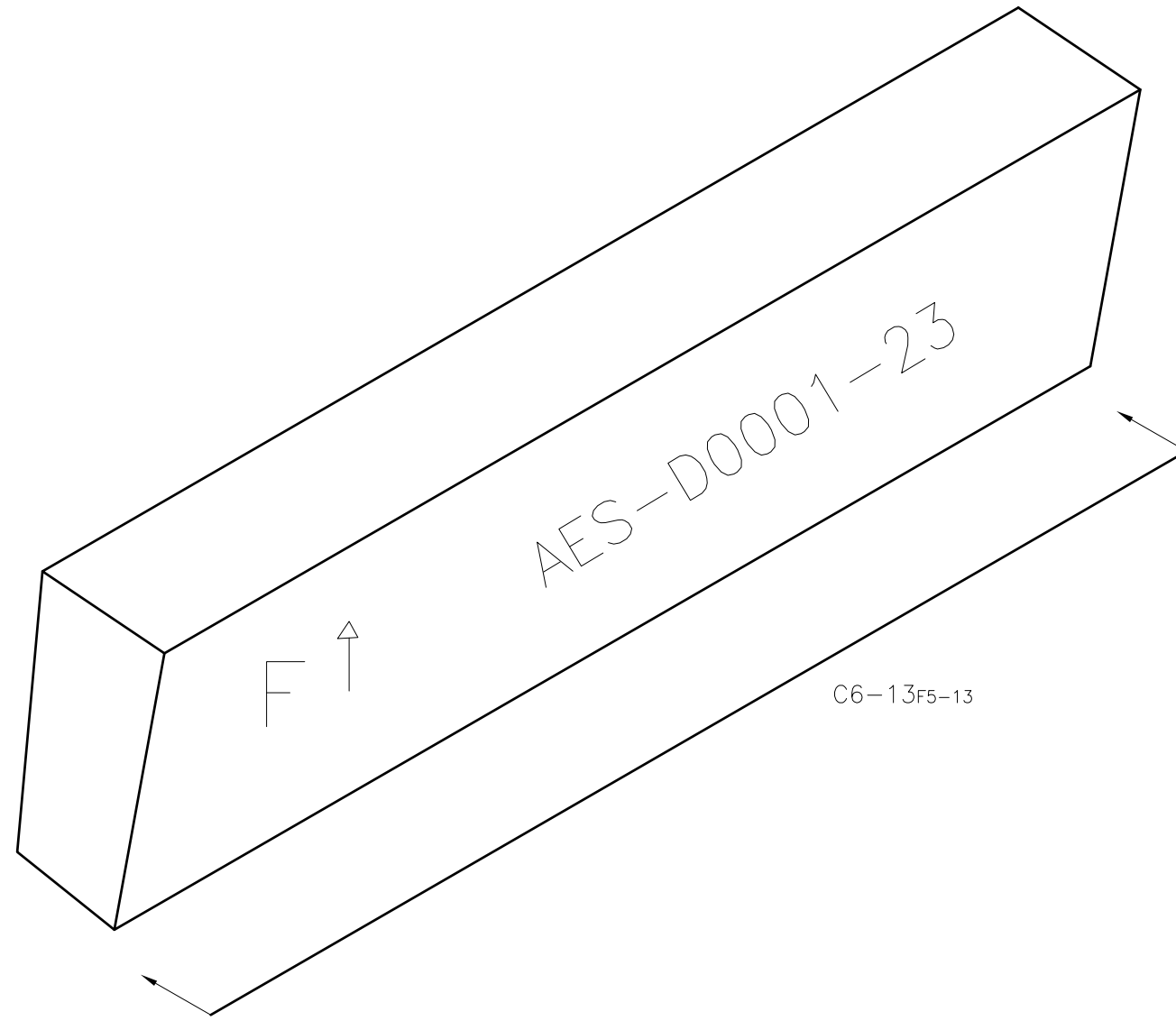

NOTE: ALL VIEWS TAKEN AS TRUE VIEWS PARALLEL TO SURFACE OF PART



DRAWING NUMBER				
AES-D0001				
SIZE	SCALE	SHEET	OF	REVISION
A3	NONE	13	124	E

— 25

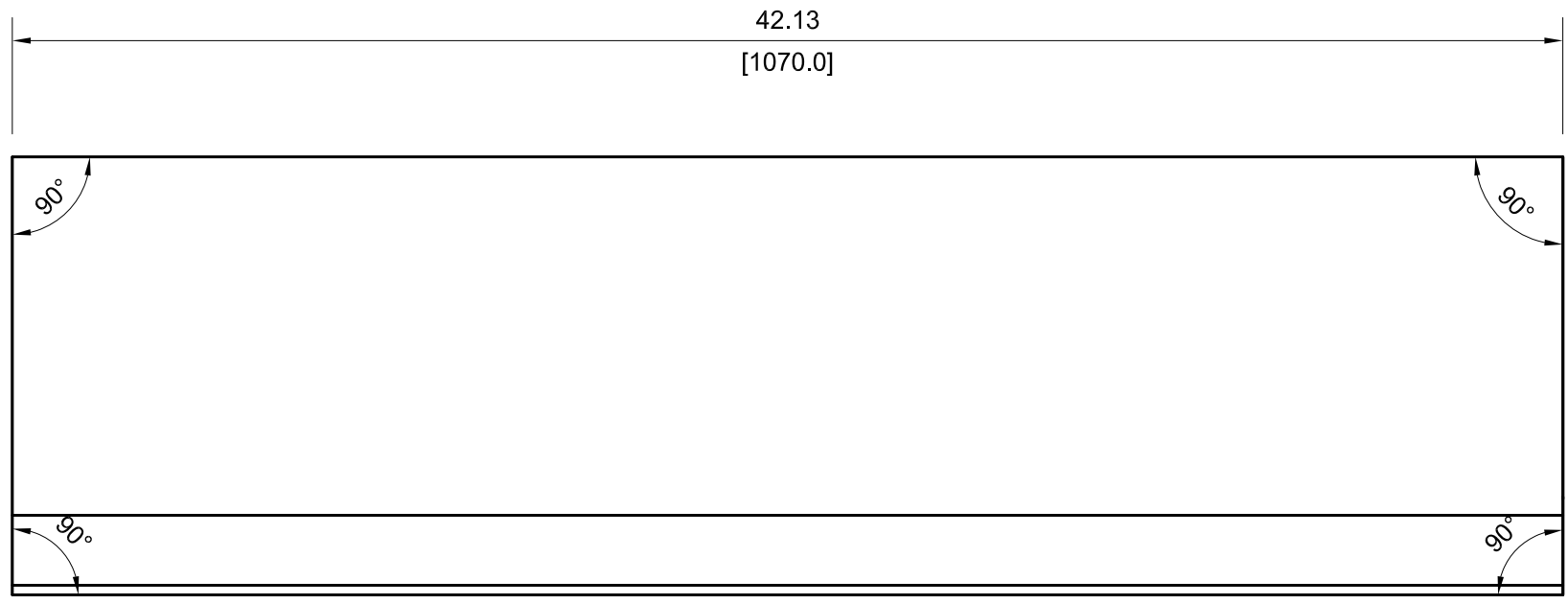
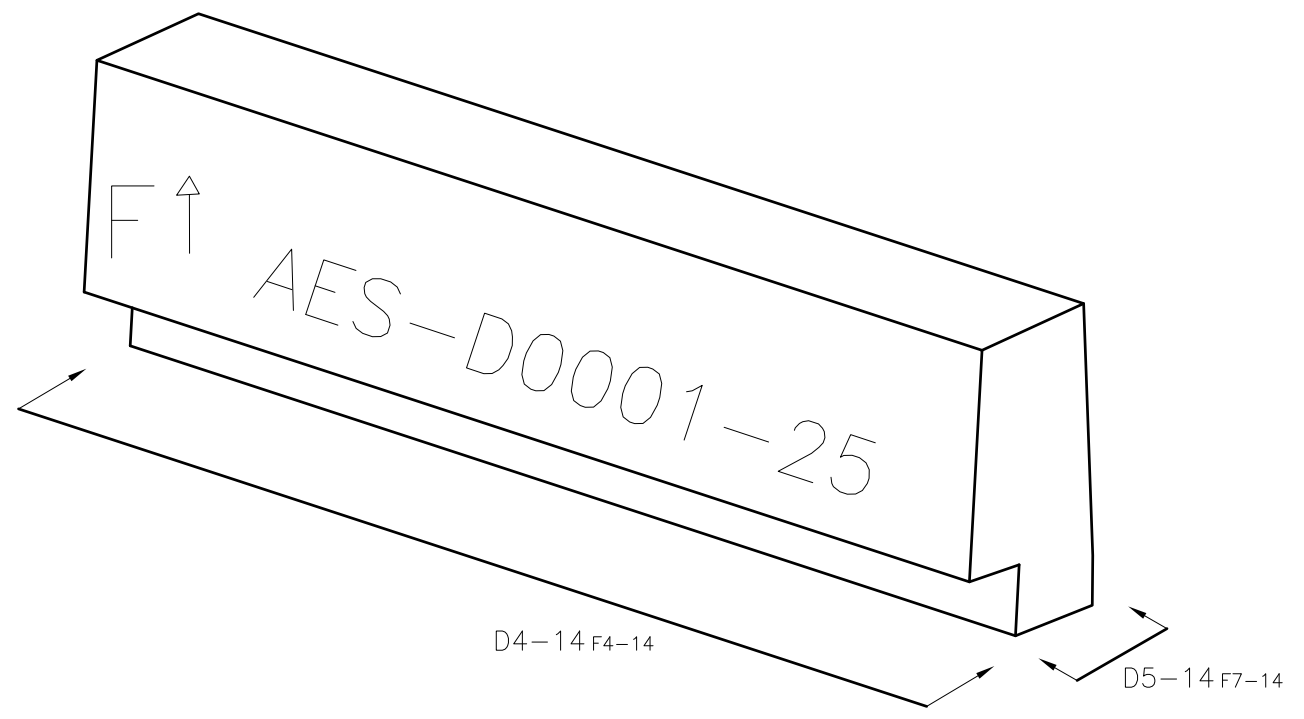

VIEW D4-14

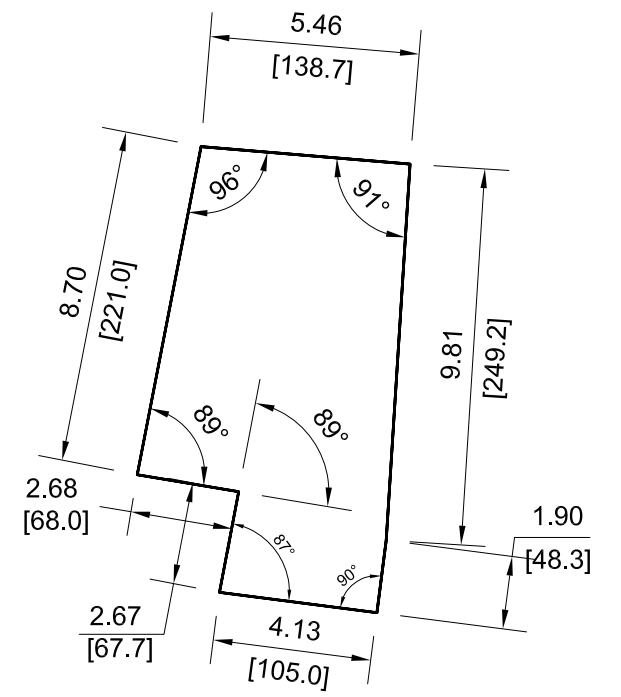

VIEW D5-14

NOTE: ALL VIEWS TAKEN AS TRUE VIEWS PARALLEL TO SURFACE OF PART

	DRAWING NUMBER				
	AES-D0001				
SIZE	SCALE	SHEET	OF	REVISION	
A3	NONE	14	124	E	

1 2 3 4 5 6 7 8

A  
B  
C  
D  
E  
F

-27

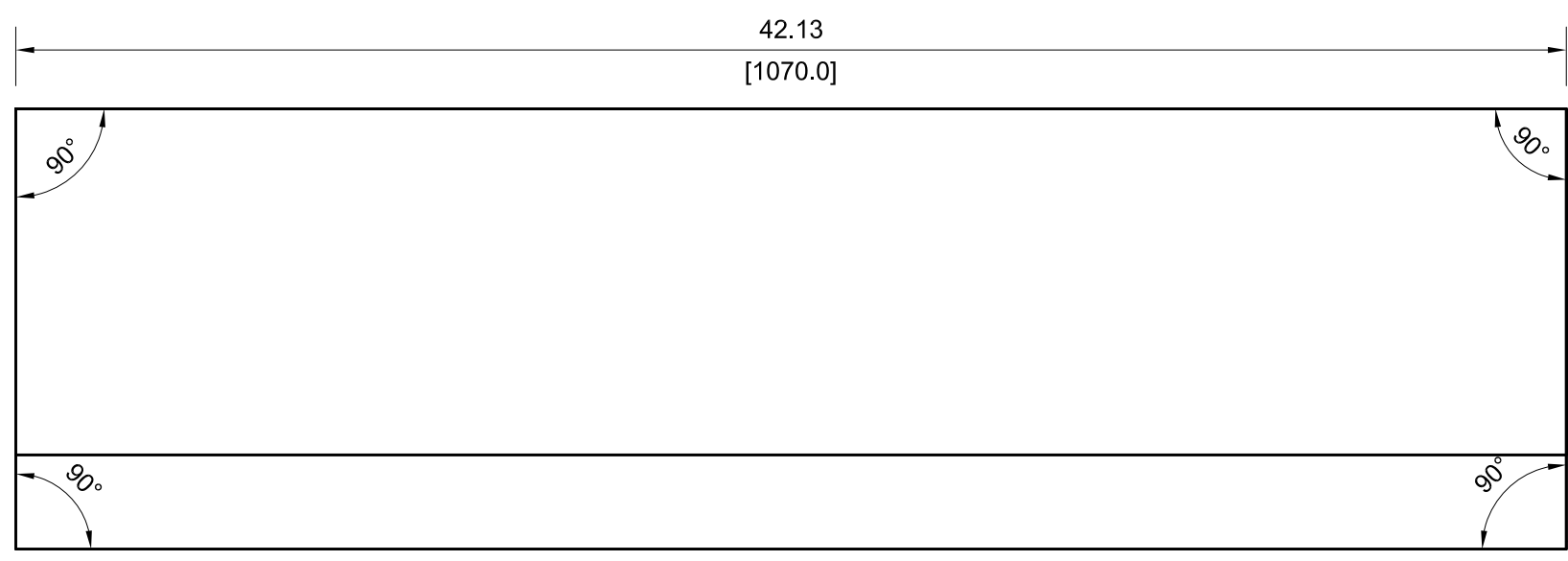
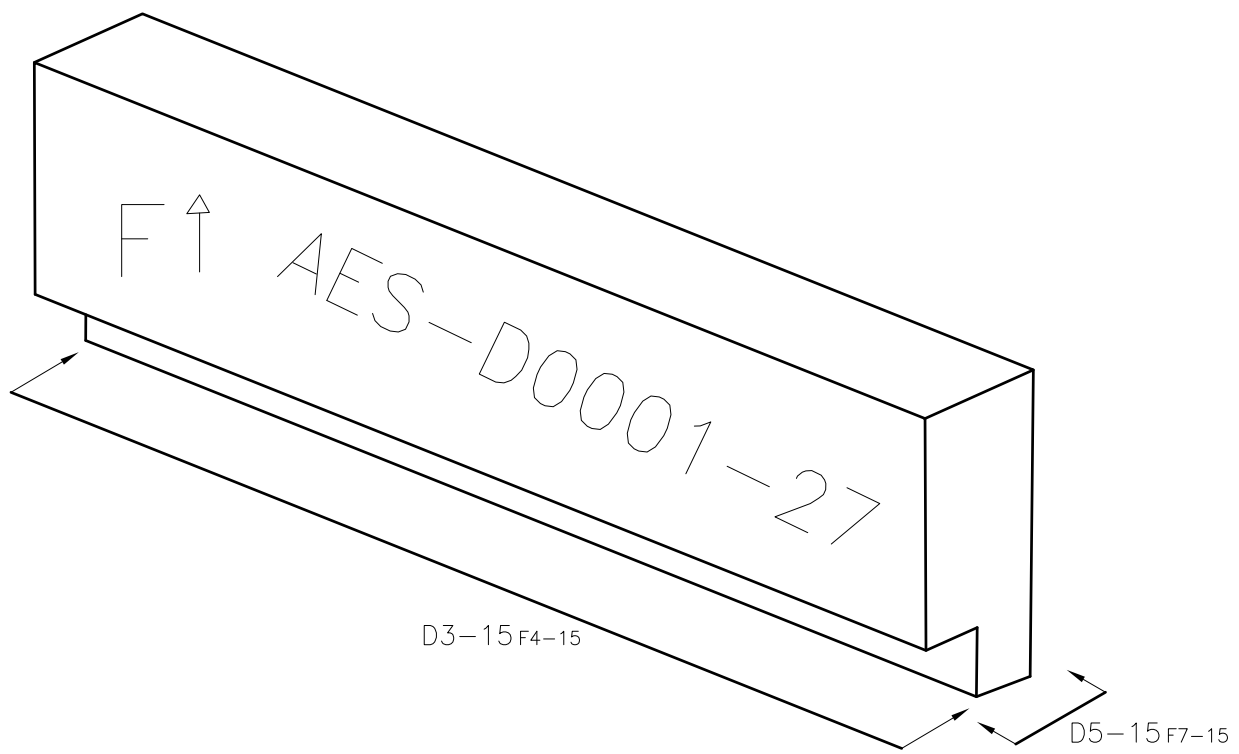

VIEW D3-15

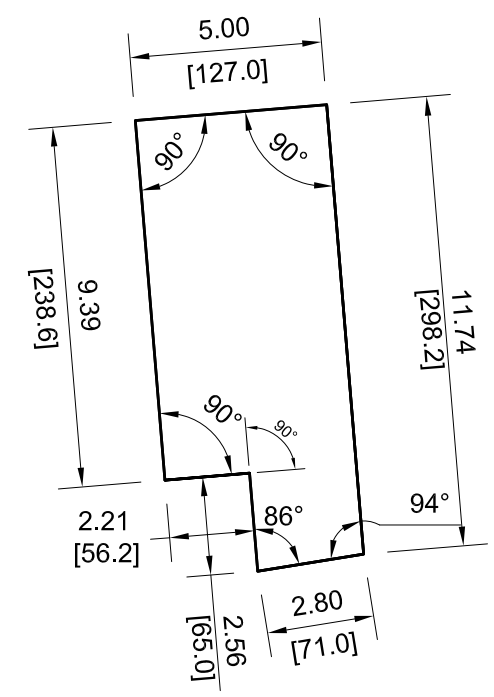

VIEW D5-15

NOTE: ALL VIEWS TAKEN AS TRUE VIEWS PARALLEL TO SURFACE OF PART



DRAWING NUMBER					AES-D0001	
SIZE	SCALE	SHEET	OF	REVISION		
A3	NONE	15	124	E		

1 2 3 4 5 6 7 8

29

B2-16 F7-16

B4-16 F3-16

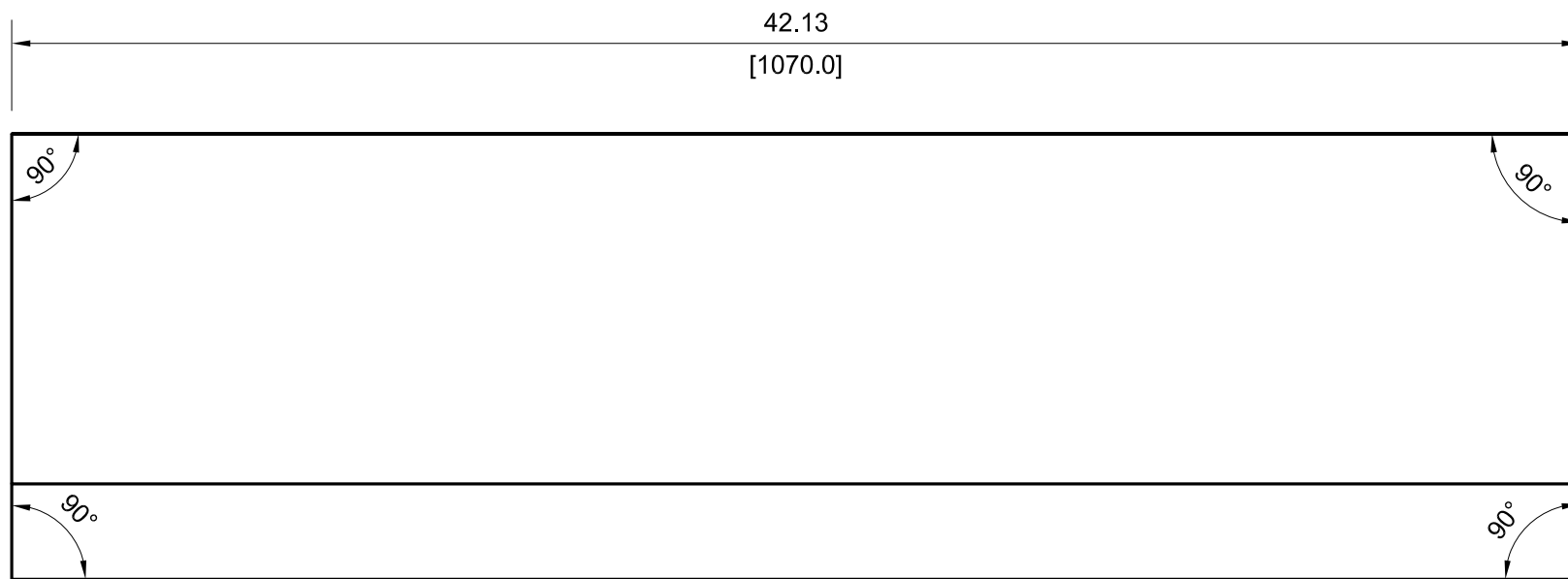
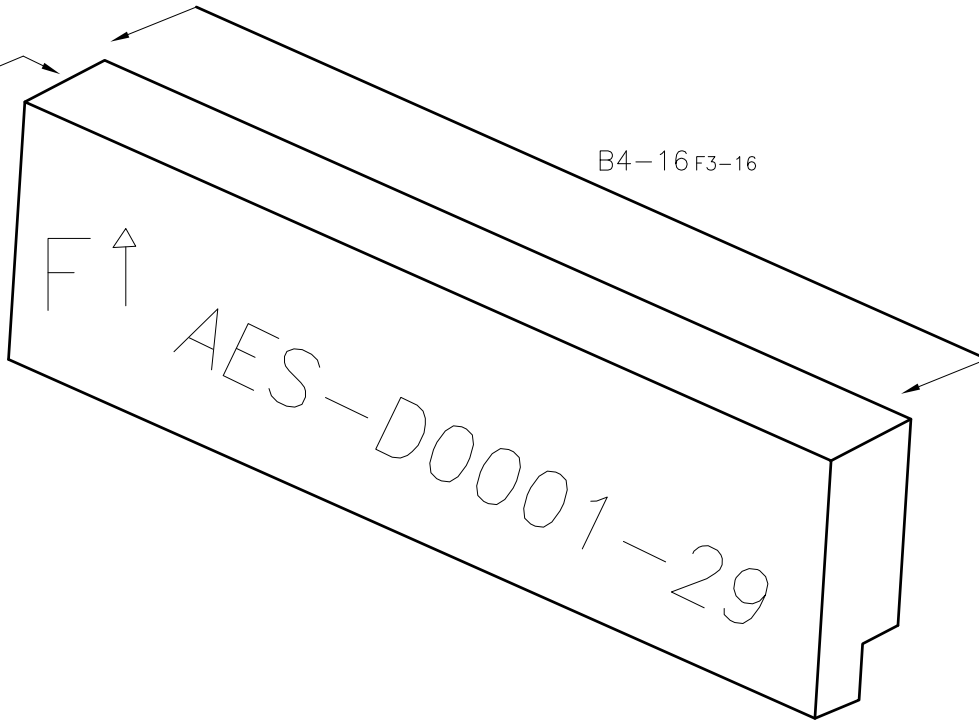

VIEW B4-16



VIEW B2-16

NOTE: ALL VIEWS TAKEN AS TRUE VIEWS PARALLEL TO SURFACE OF PART



DRAWING NUMBER					AES-D0001	
SIZE	SCALE	SHEET	OF	REVISION		
A3	NONE	16	124	E		

— 31

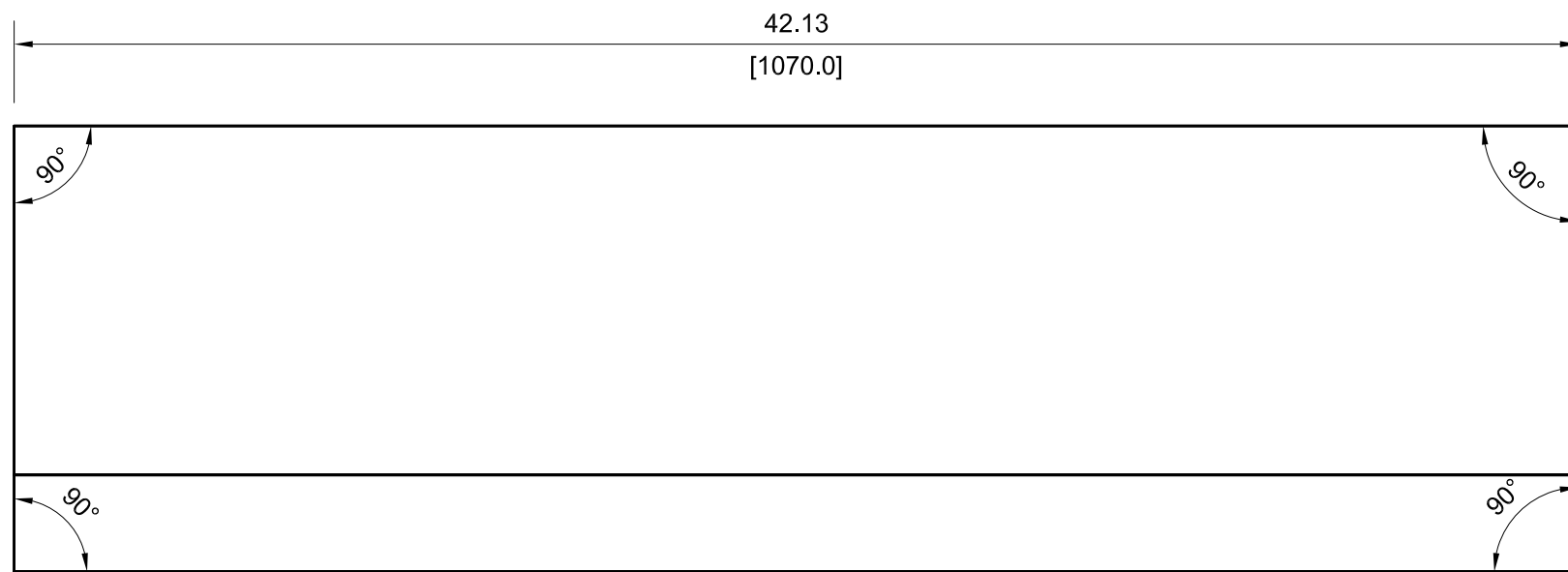
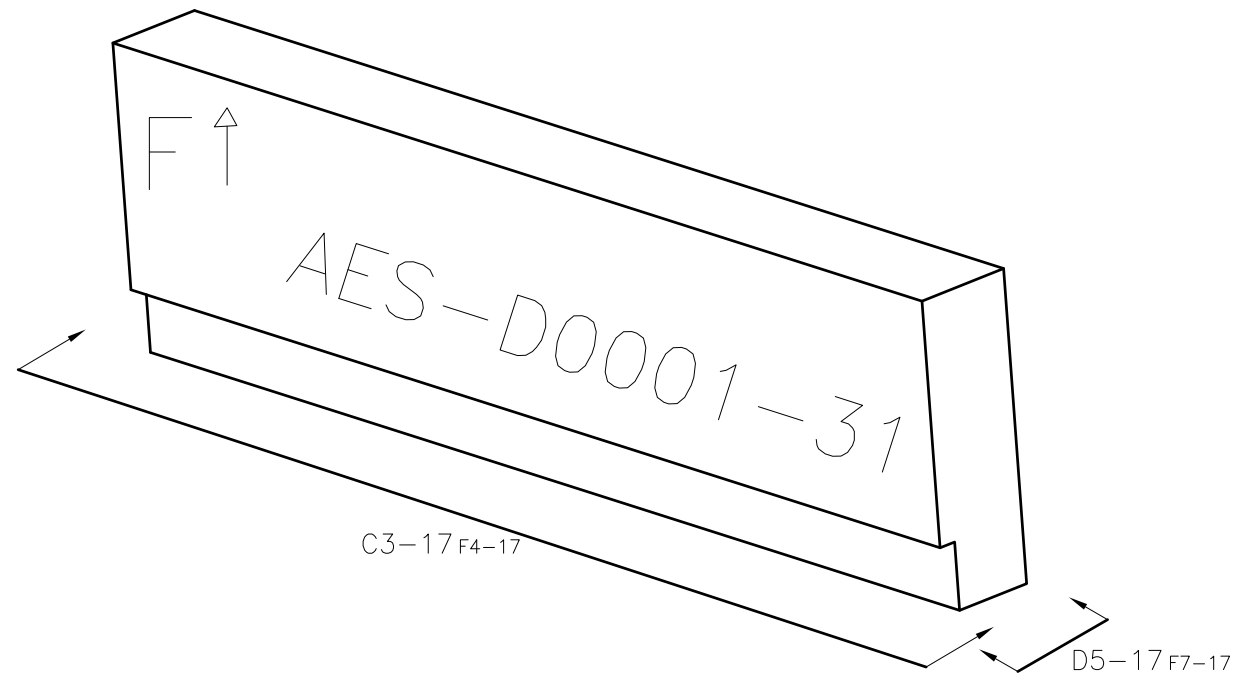

VIEW C3-17

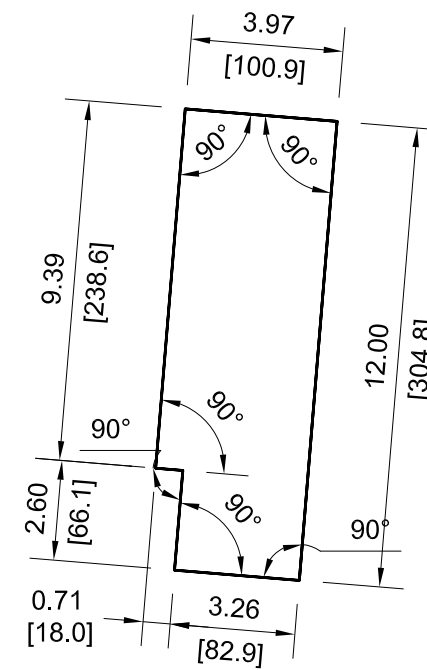

VIEW D5-17

NOTE: ALL VIEWS TAKEN AS TRUE VIEWS PARALLEL TO SURFACE OF PART



DRAWING NUMBER					AES-D0001	
SIZE	SCALE	SHEET	OF	REVISION		
A3	NONE	17	124	E		

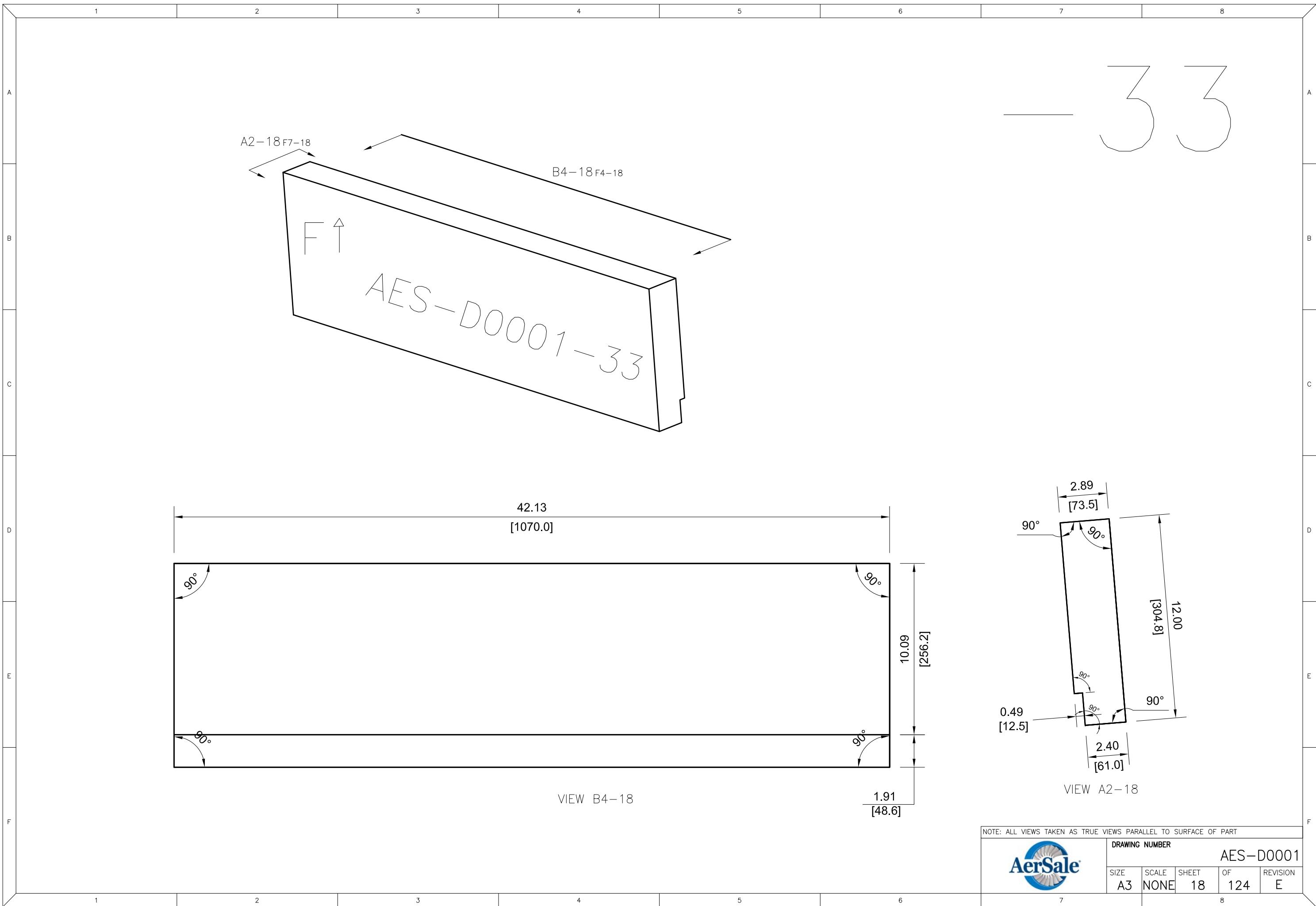

NOTE: ALL VIEWS TAKEN AS TRUE VIEWS PARALLEL TO SURFACE OF PART

	DRAWING NUMBER				
	AES-D0001				
SIZE	SCALE	SHEET	OF	REVISION	
A3	NONE	18	124	E	

— 35

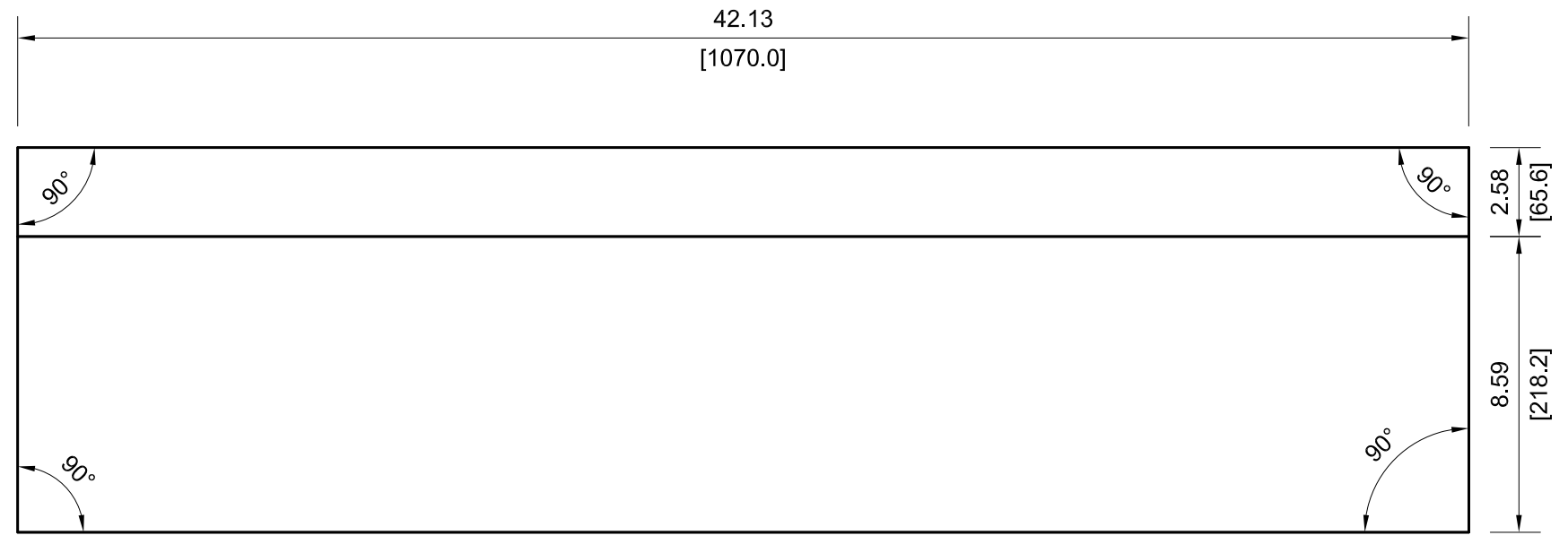
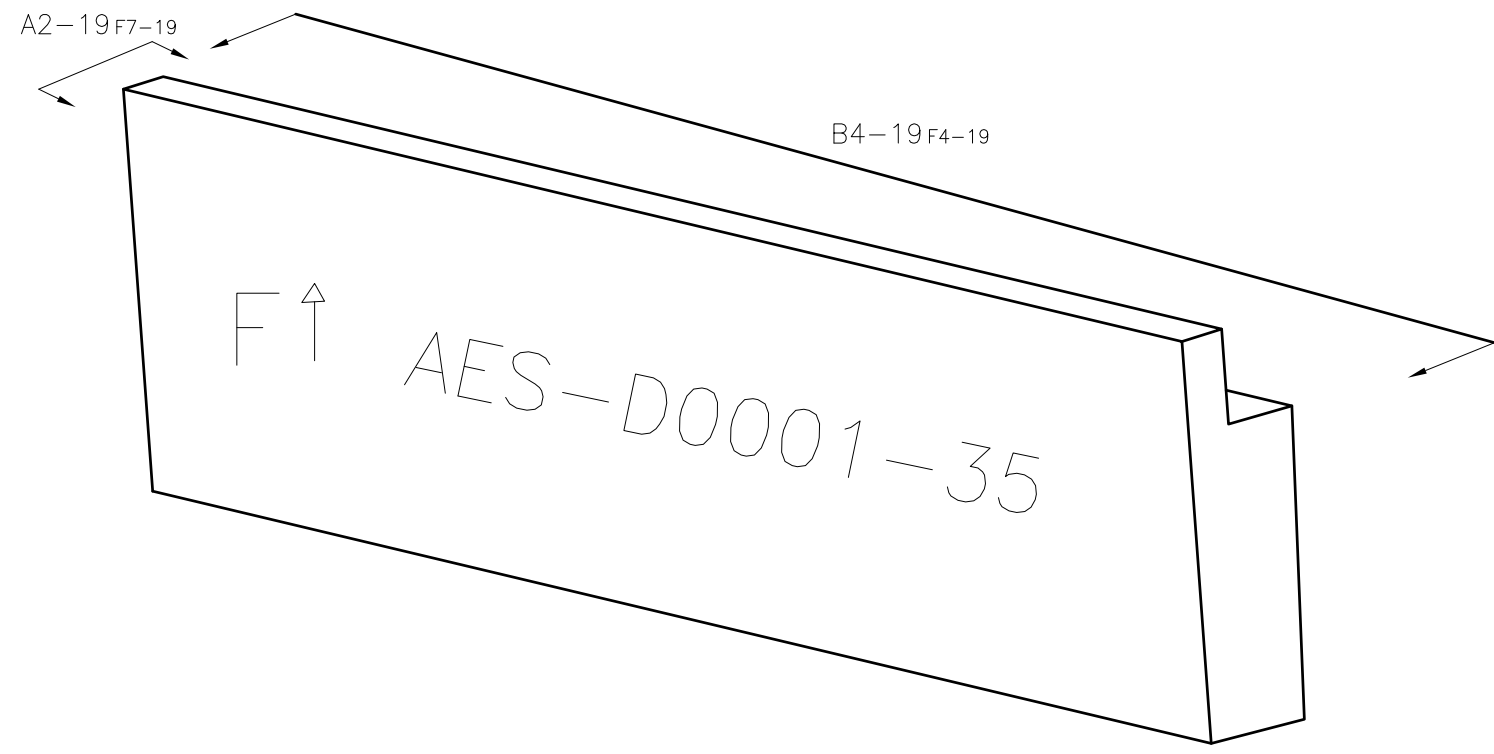

VIEW B4-19

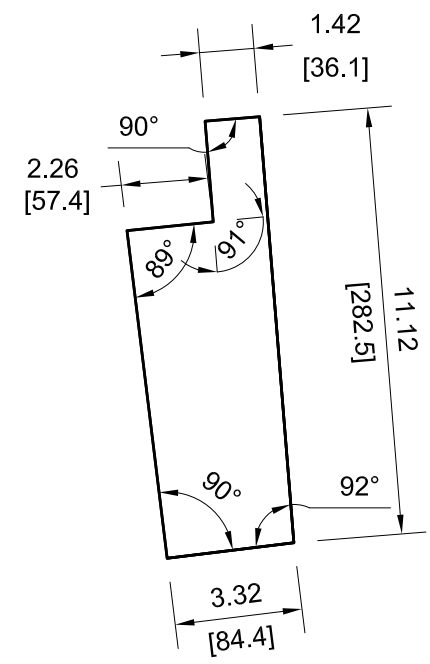

VIEW A2-19

NOTE: ALL VIEWS TAKEN AS TRUE VIEWS PARALLEL TO SURFACE OF PART

	DRAWING NUMBER				AES-D0001
	SIZE	SCALE	SHEET	OF	REVISION
A3	NONE	19	124	E	

37

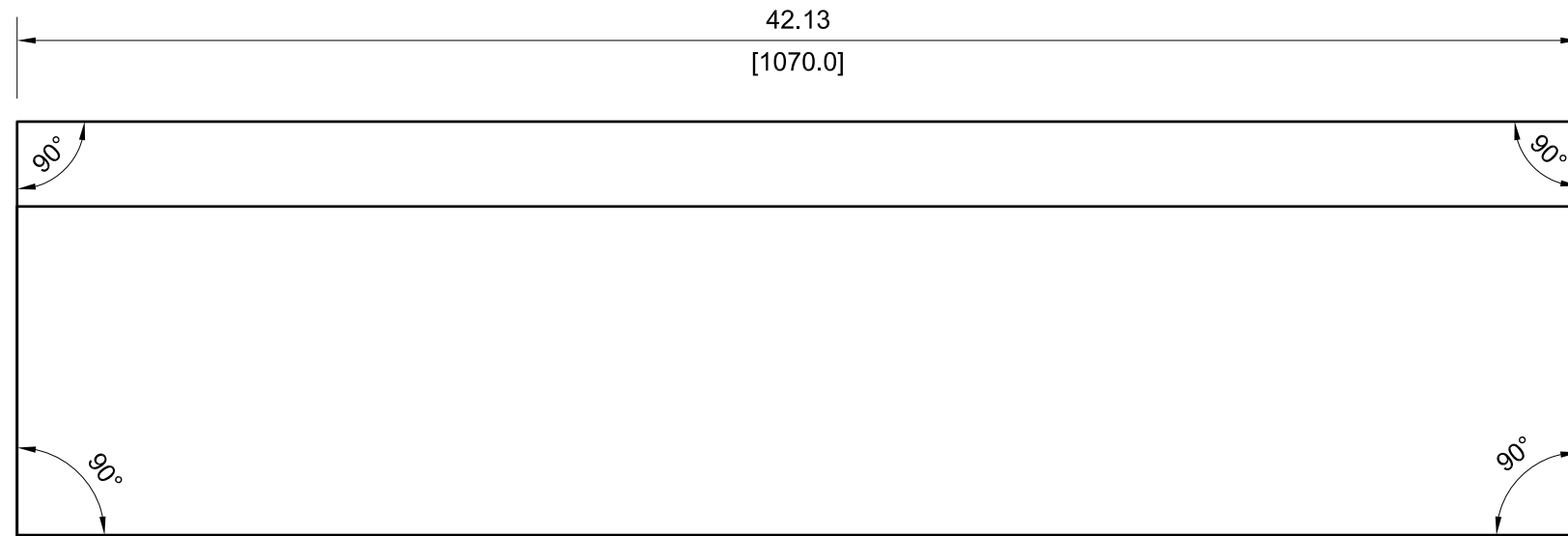
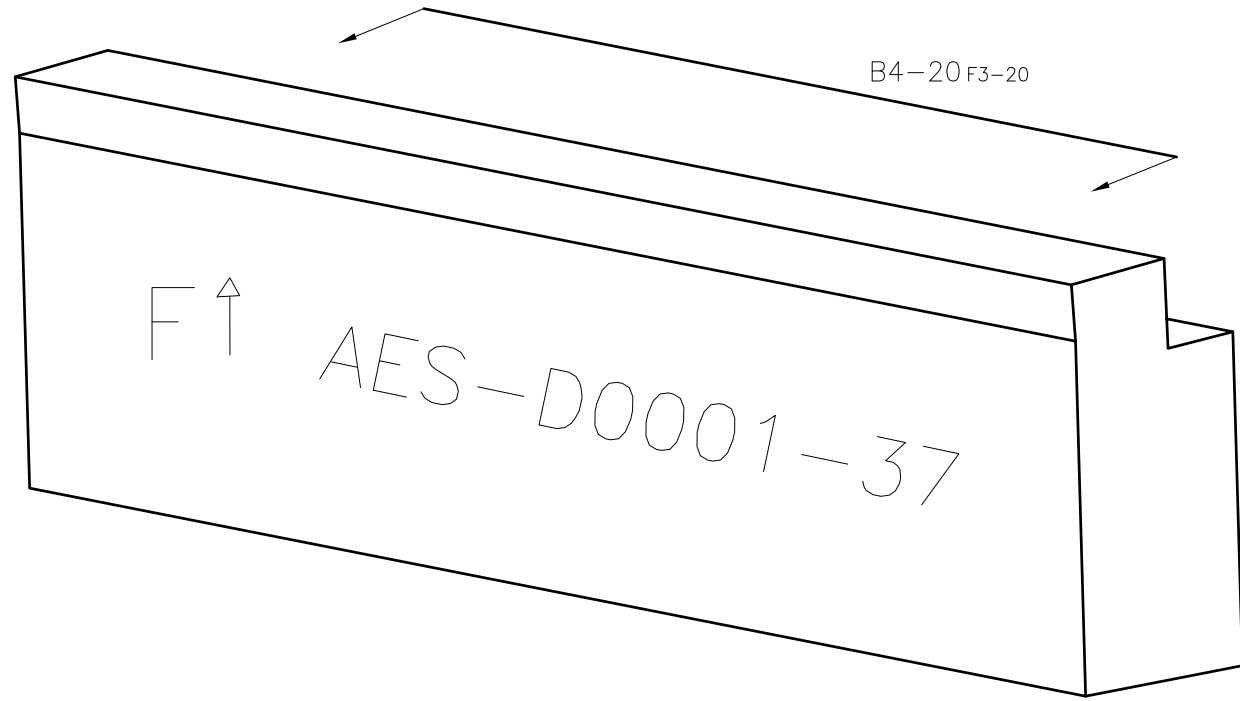

VIEW B4-20

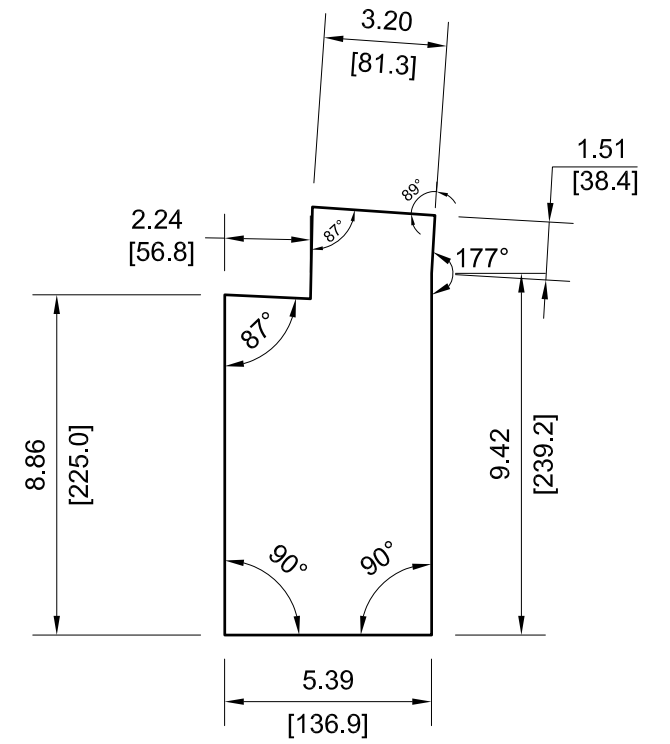

NOTE: ALL VIEWS TAKEN AS TRUE VIEWS PARALLEL TO SURFACE OF PART



DRAWING NUMBER					AES-D0001				
SIZE	SCALE	SHEET	OF	REVISION					
A3	NONE	20	124	E					

— 39

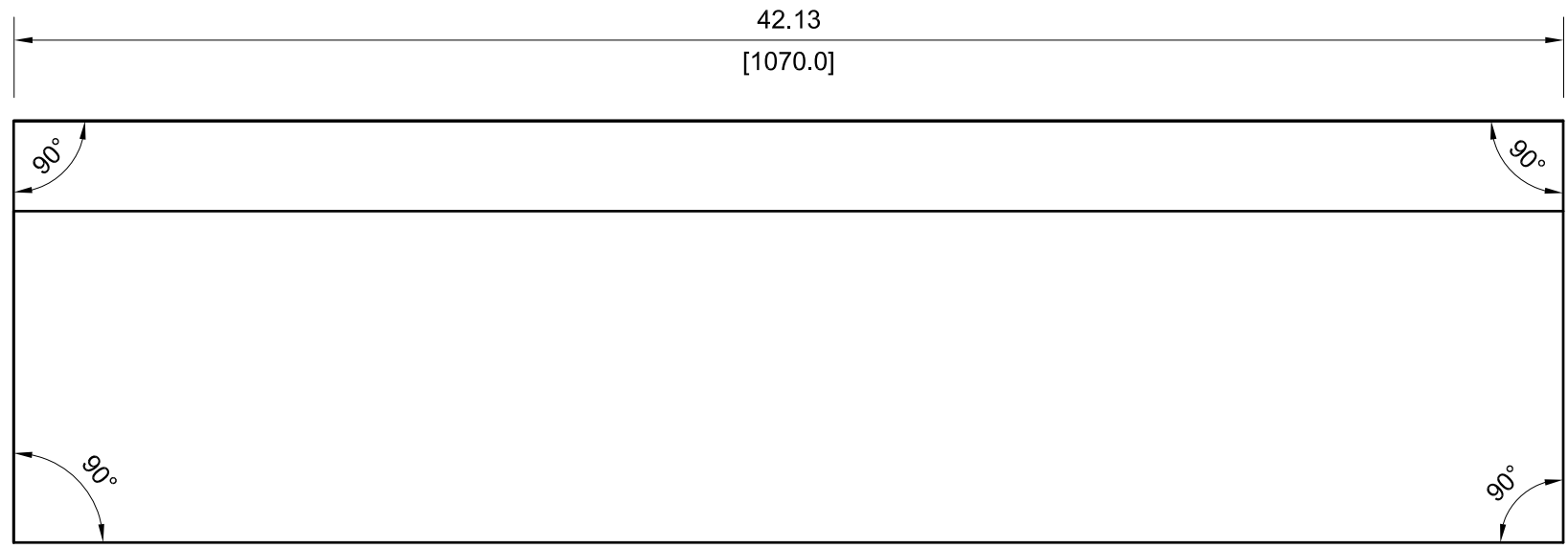
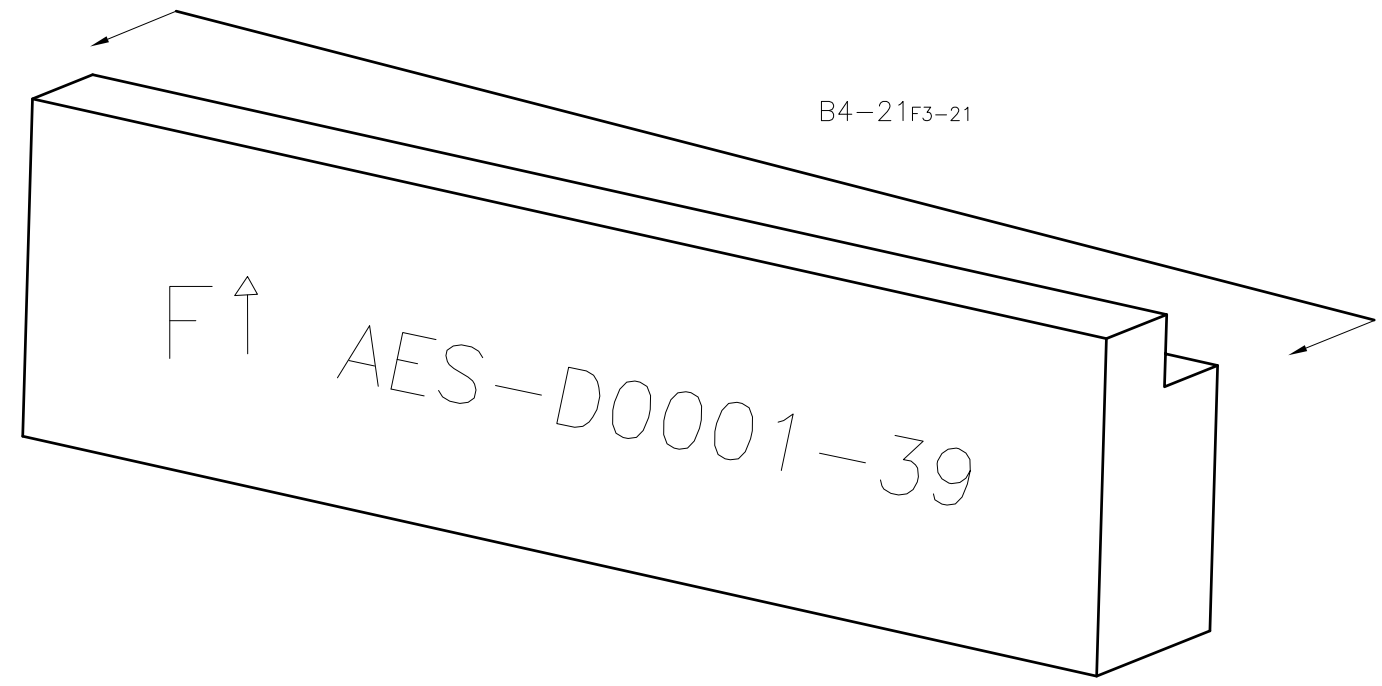

VIEW B4-21

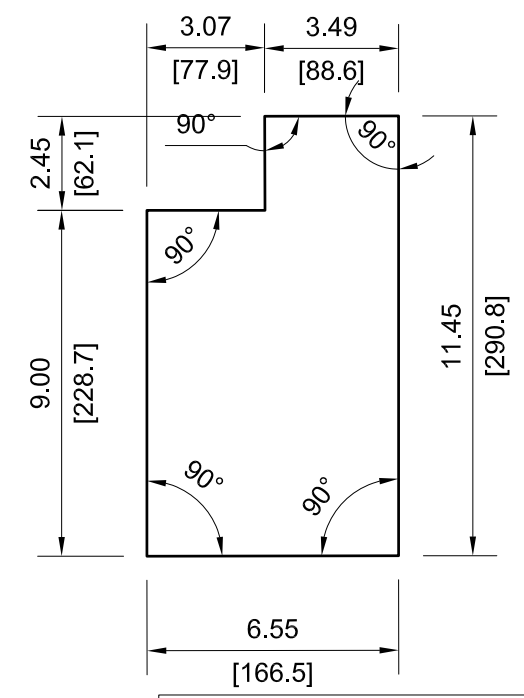

NOTE: ALL VIEWS TAKEN AS TRUE VIEWS PARALLEL TO SURFACE OF PART

	DRAWING NUMBER				AES-D0001
	SIZE	SCALE	SHEET	OF	REVISION
A3	NONE	21	124	E	

1 2 3 4 5 6 7 8

A  
B  
C  
D  
E  
F

41

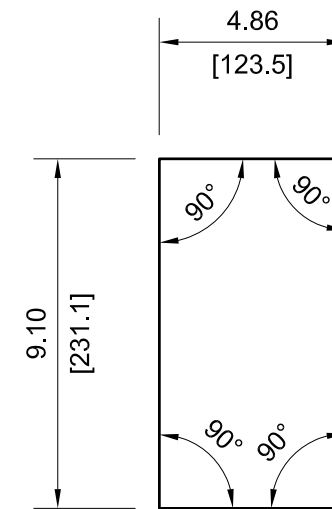
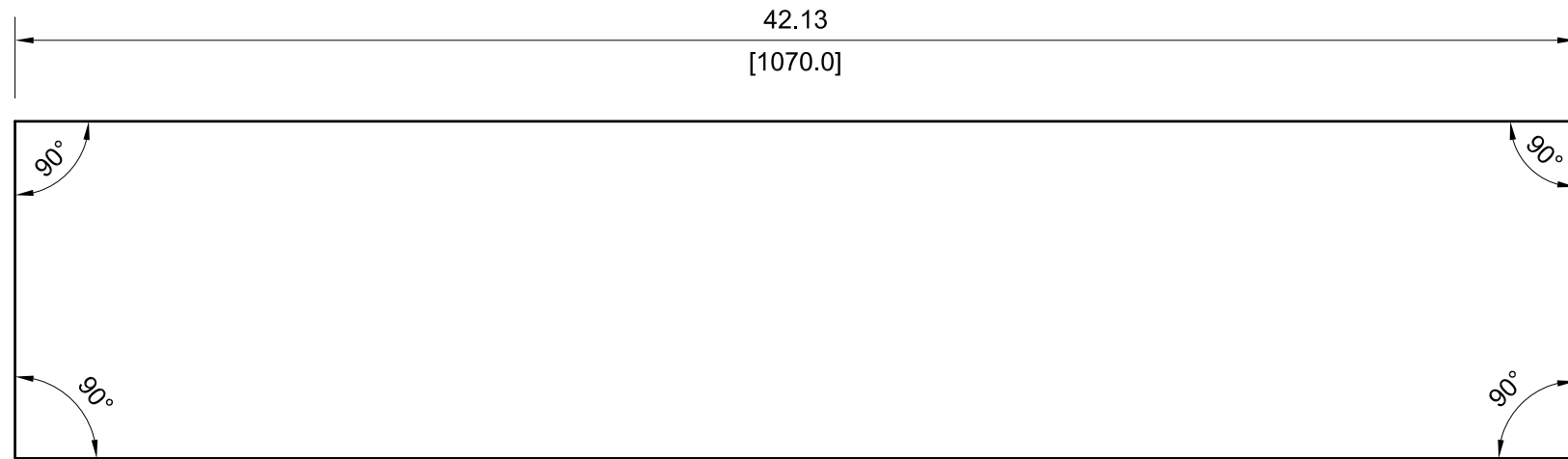
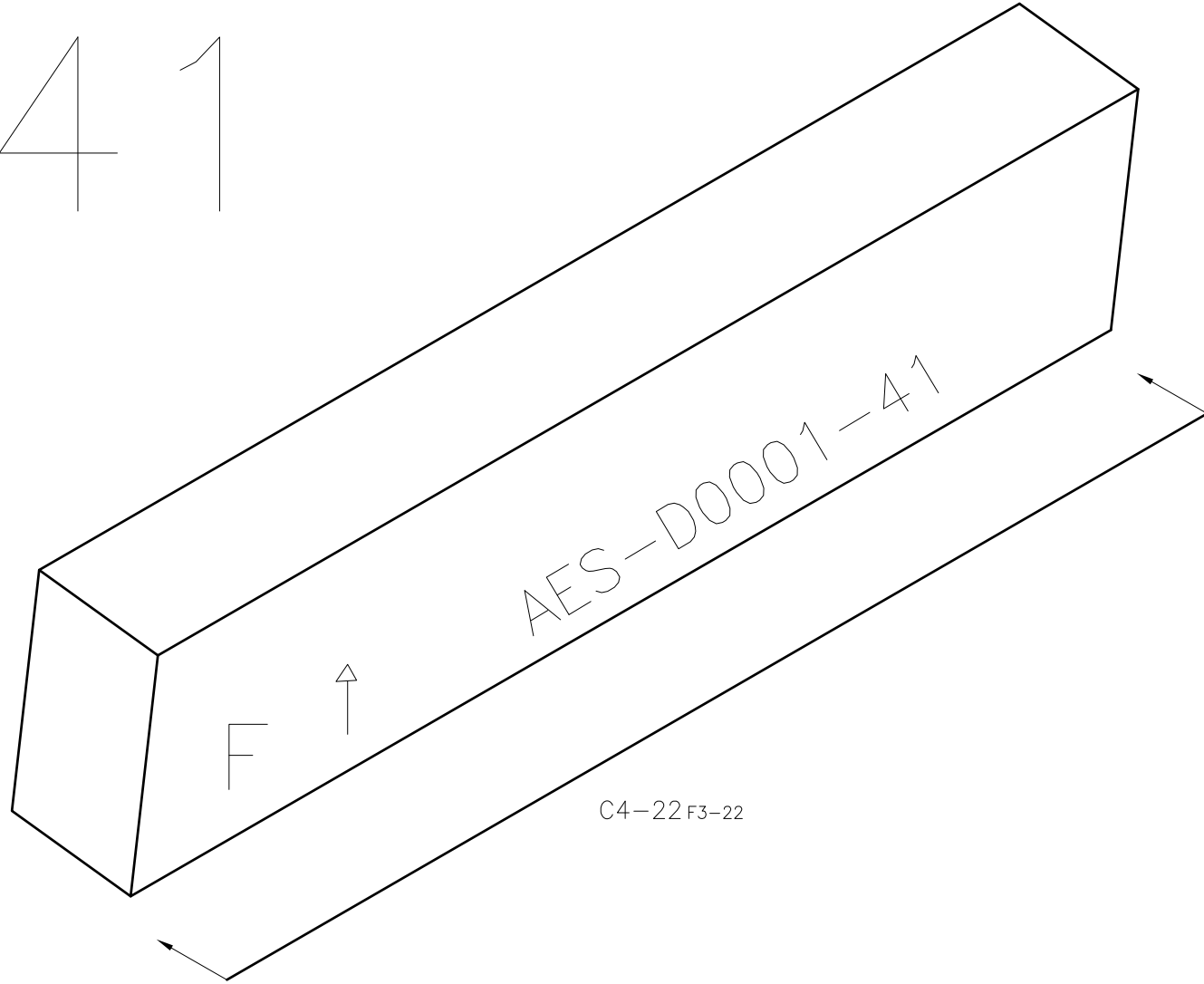

VIEW C4-22

NOTE: ALL VIEWS TAKEN AS TRUE VIEWS PARALLEL TO SURFACE OF PART



DRAWING NUMBER					AES-D0001	
SIZE	SCALE	SHEET	OF	REVISION		
A3	NONE	22	124	E		

1 2 3 4 5 6 7 8

43

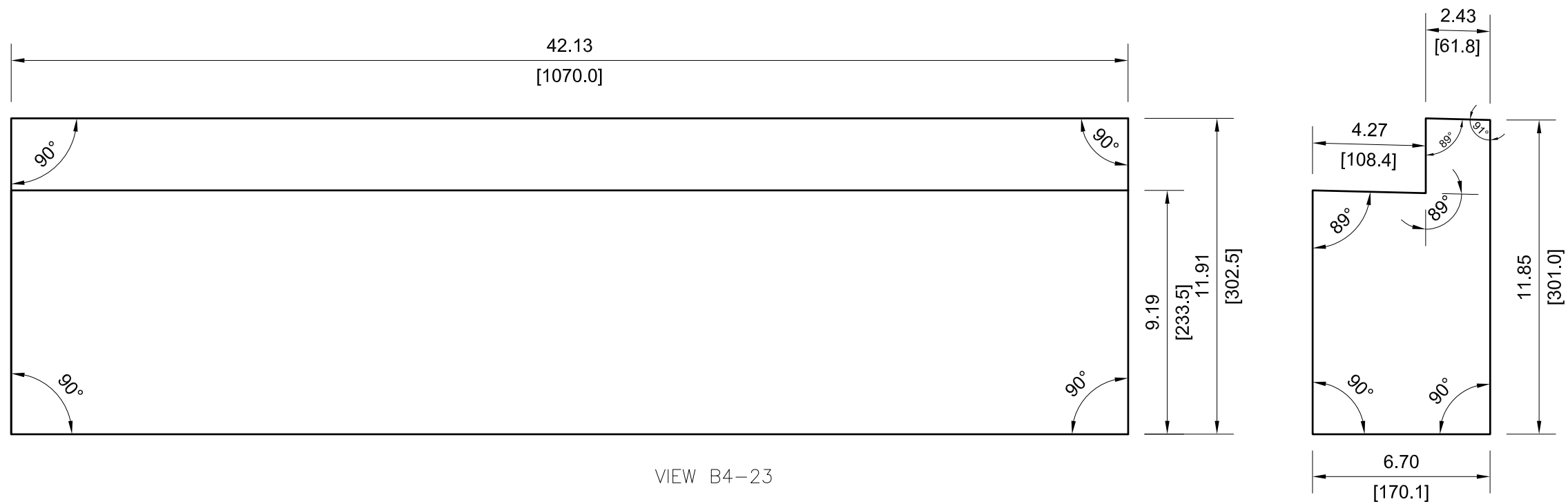
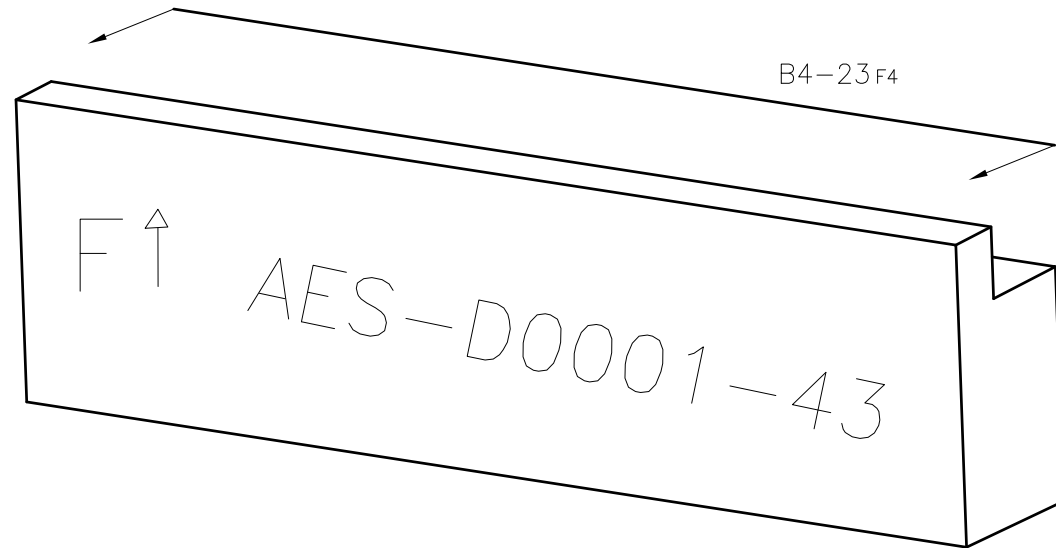

VIEW B4-23

NOTE: ALL VIEWS TAKEN AS TRUE VIEWS PARALLEL TO SURFACE OF PART



DRAWING NUMBER				
AES-D0001				
SIZE	SCALE	SHEET	OF	REVISION
A3	NONE	23	124	E

— 45

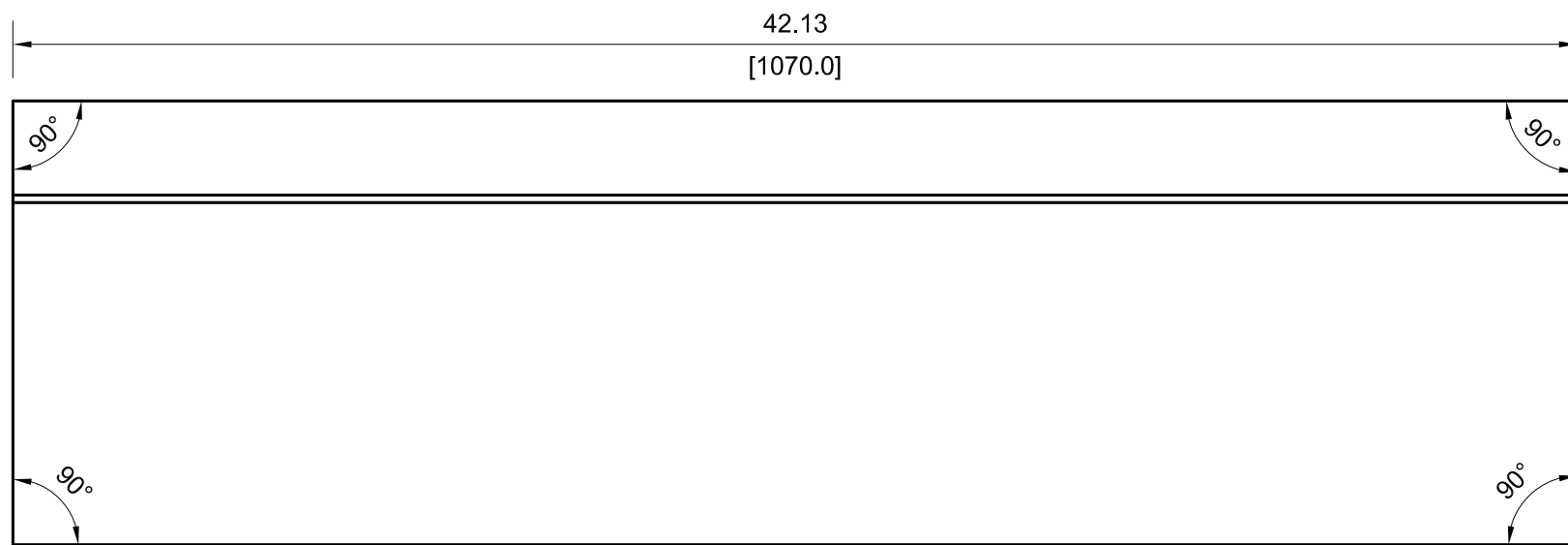
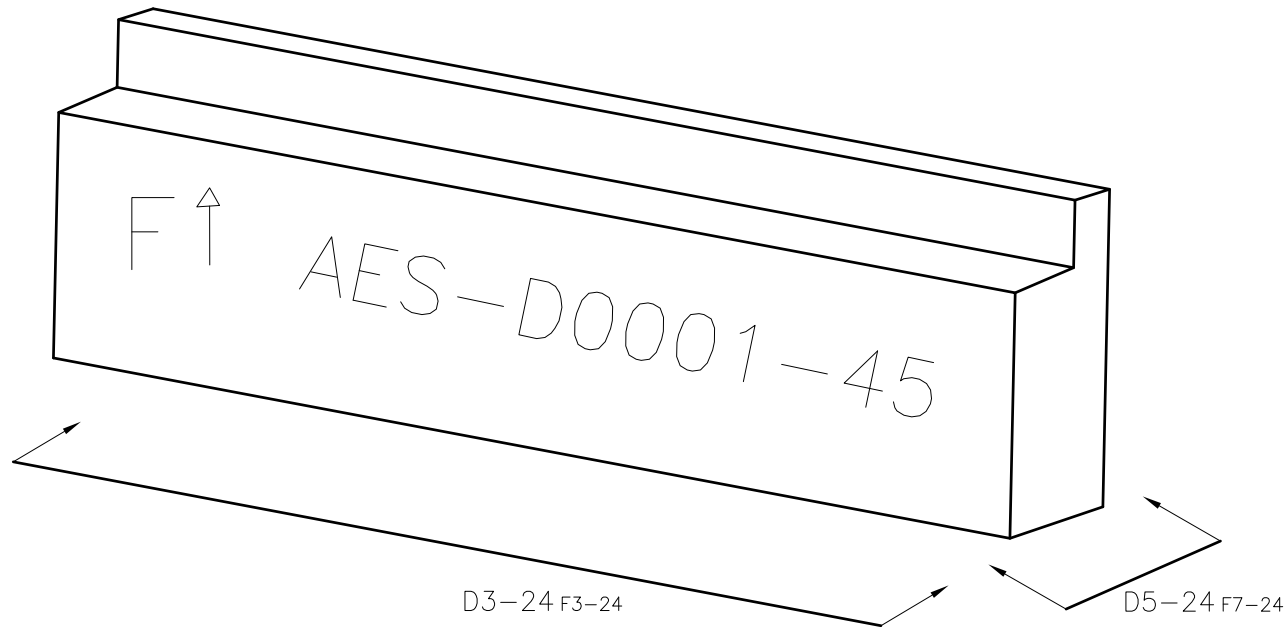

VIEW D3-24

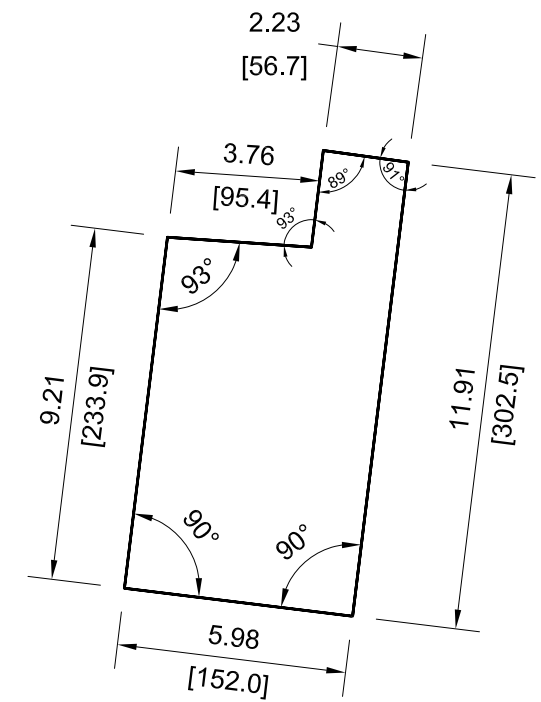

VIEW D5-24

NOTE: ALL VIEWS TAKEN AS TRUE VIEWS PARALLEL TO SURFACE OF PART



DRAWING NUMBER					AES-D0001	
SIZE	SCALE	SHEET	OF	REVISION		
A3	NONE	24	124	E		

47

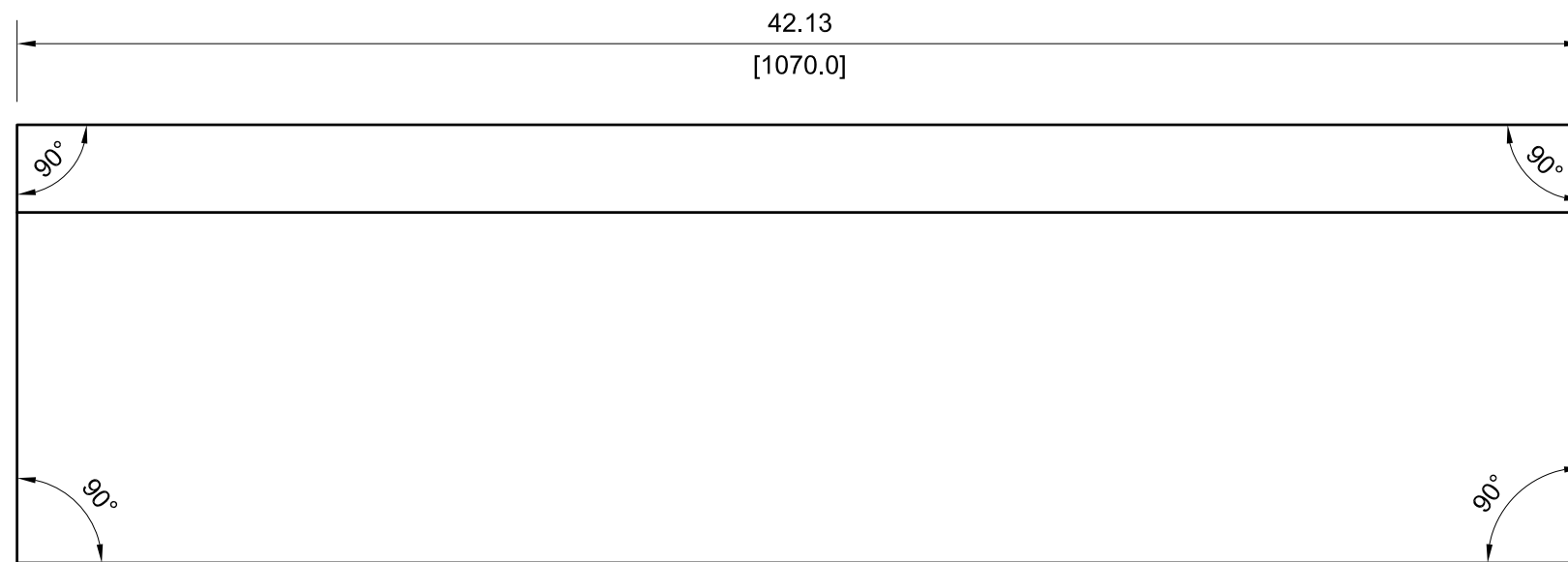
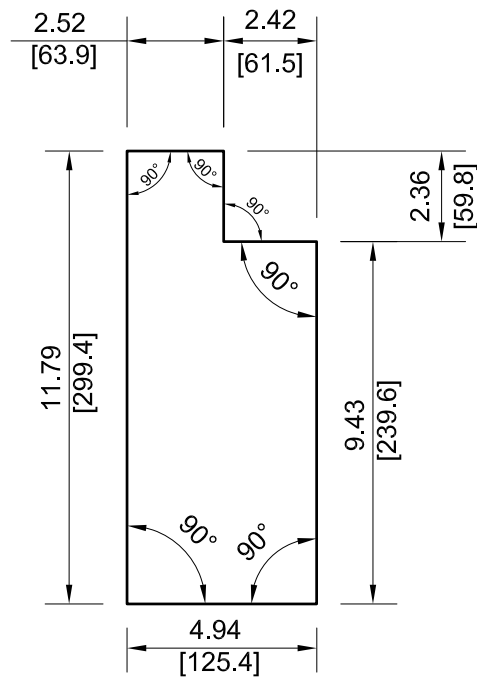
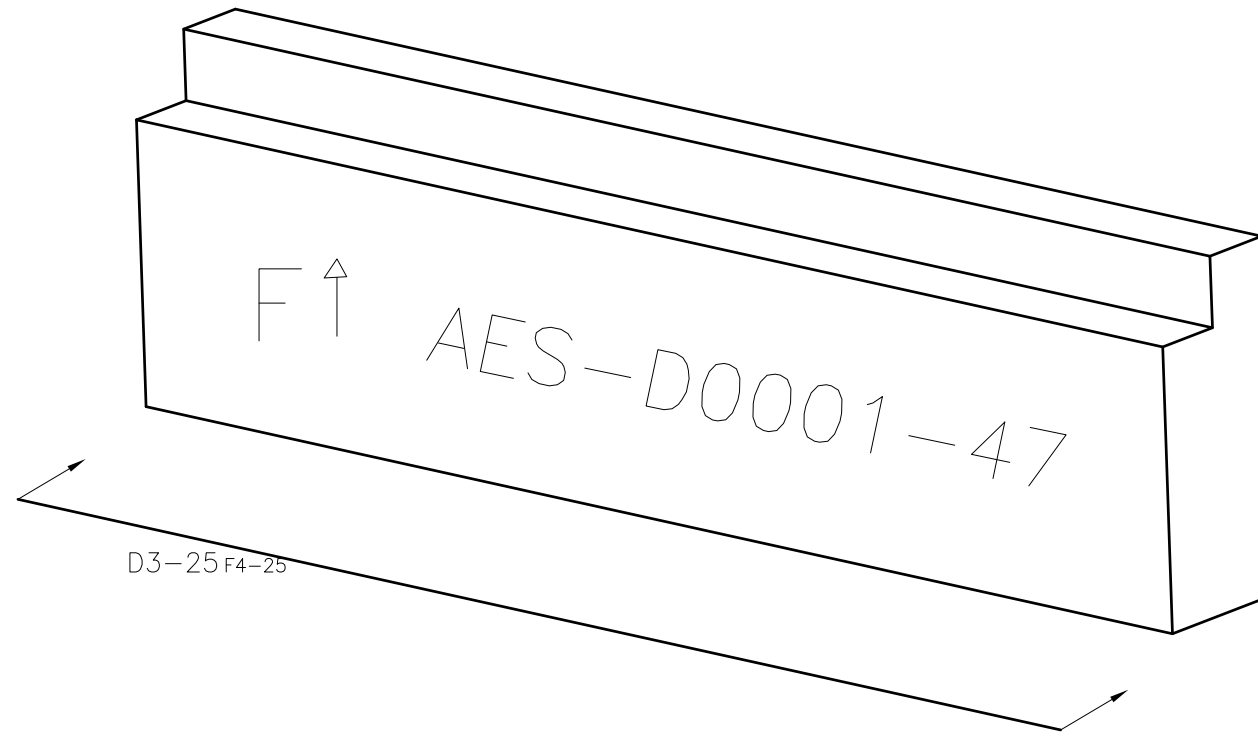

VIEW D3-25

NOTE: ALL VIEWS TAKEN AS TRUE VIEWS PARALLEL TO SURFACE OF PART

	DRAWING NUMBER				AES-D0001
	SIZE	SCALE	SHEET	OF	REVISION
A3	NONE	25	124	E	

— 49

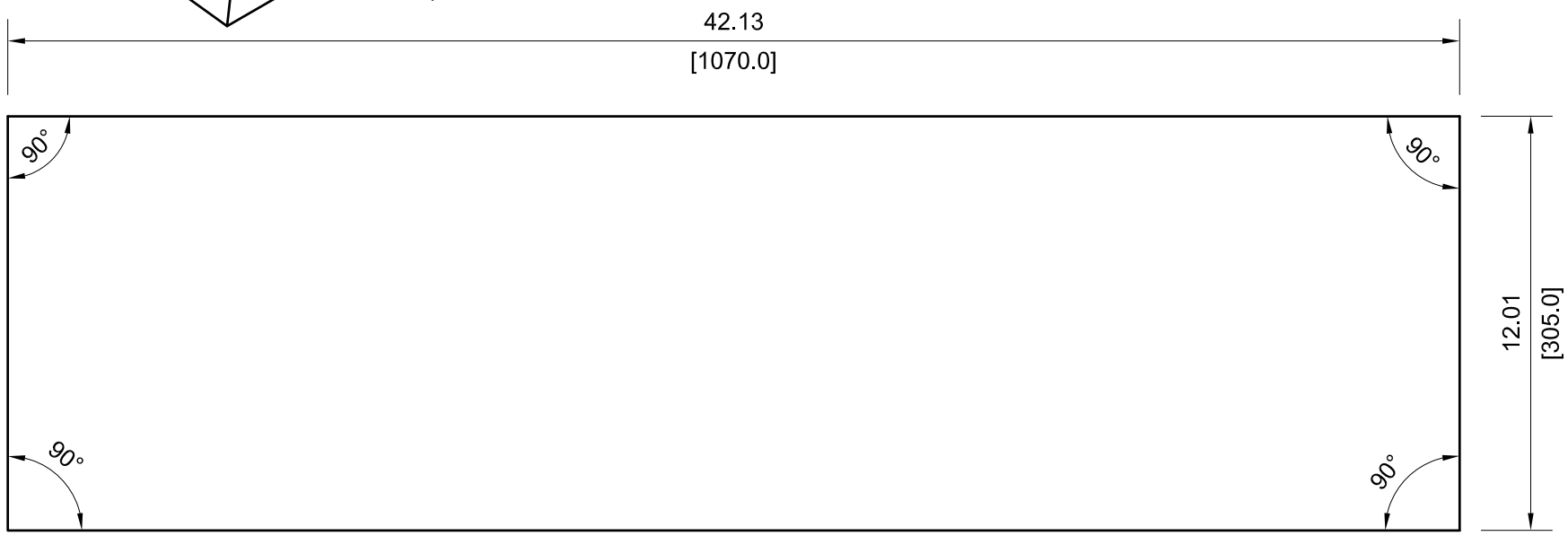
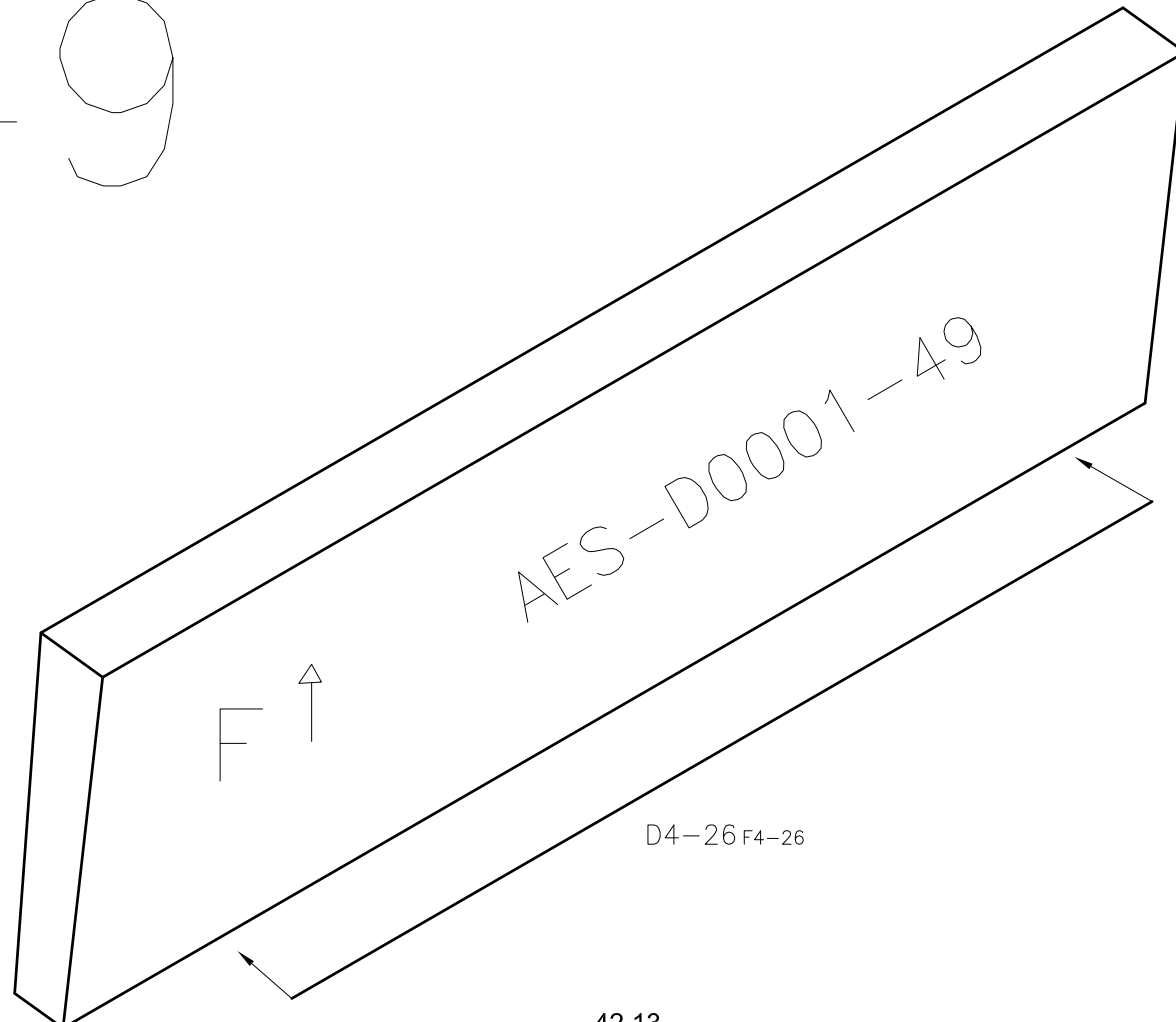

VIEW D4-26

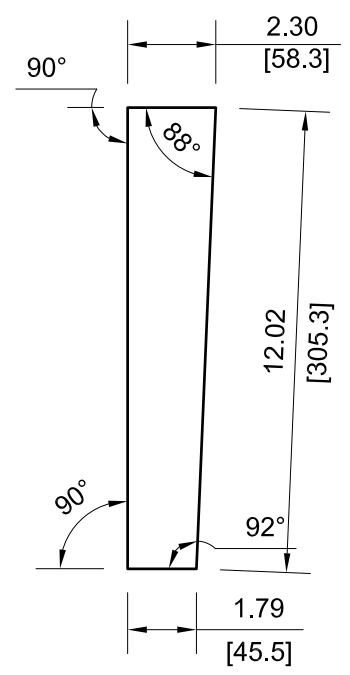

NOTE: ALL VIEWS TAKEN AS TRUE VIEWS PARALLEL TO SURFACE OF PART

	DRAWING NUMBER				AES-D0001	
	SIZE	SCALE	SHEET	OF	REVISION	
A3	NONE	26	124	E		

— 51

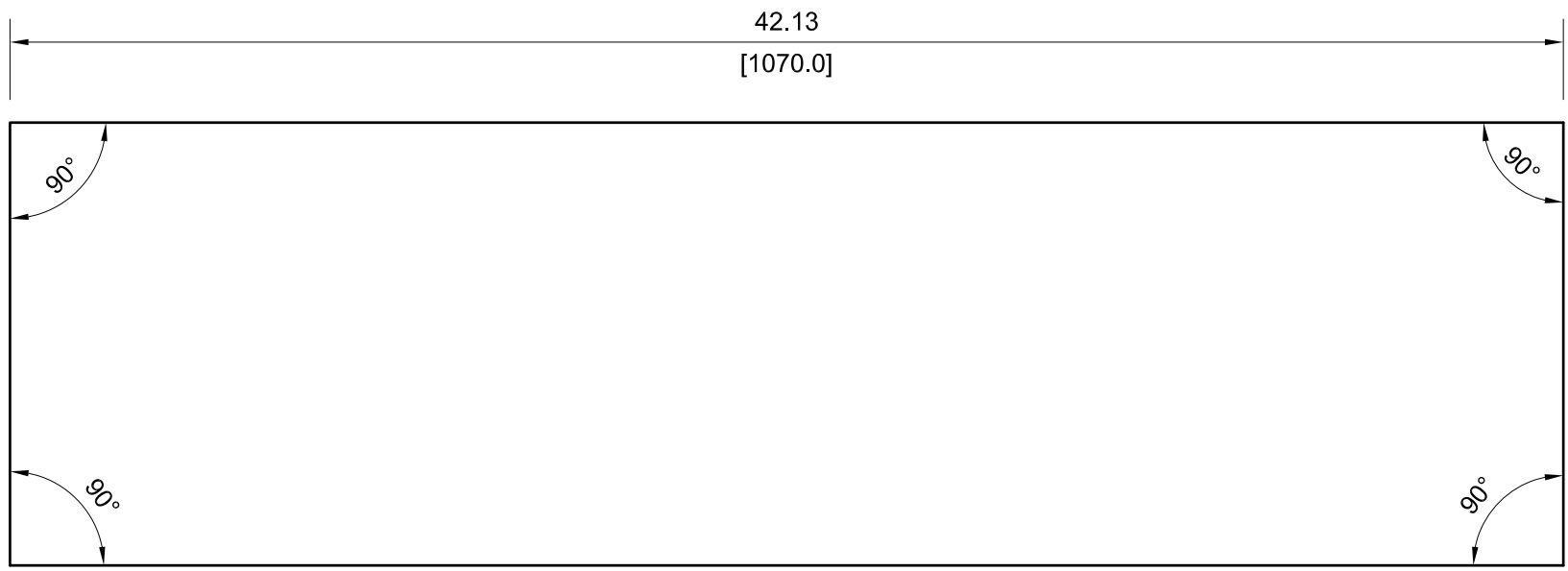
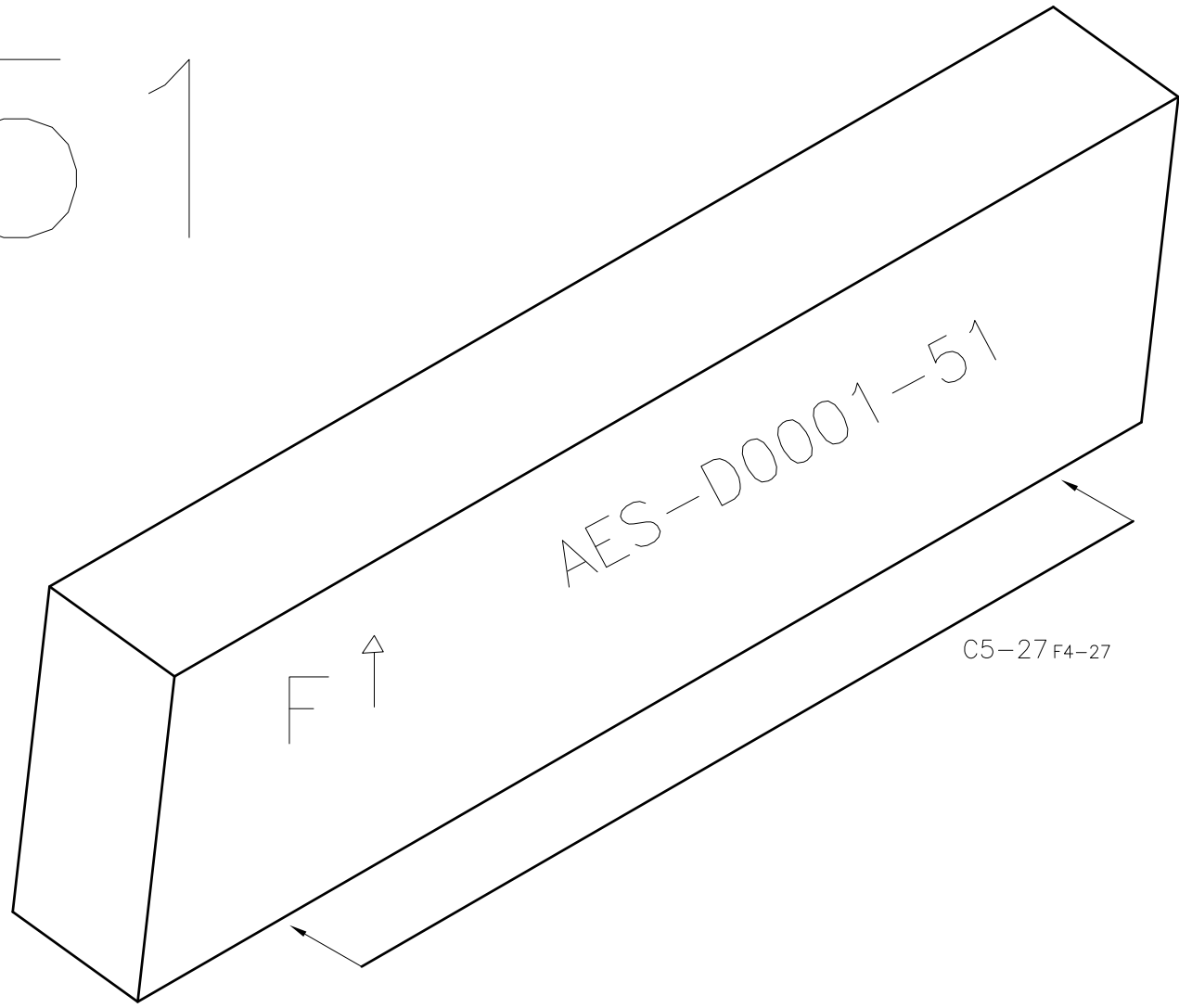

VIEW C5-27

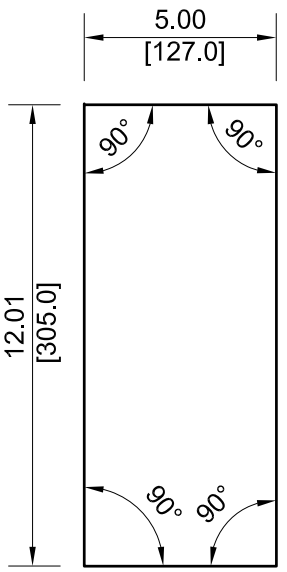

NOTE: ALL VIEWS TAKEN AS TRUE VIEWS PARALLEL TO SURFACE OF PART



DRAWING NUMBER				
AES-D0001				
SIZE	SCALE	SHEET	OF	REVISION
A3	NONE	27	124	E

— 53

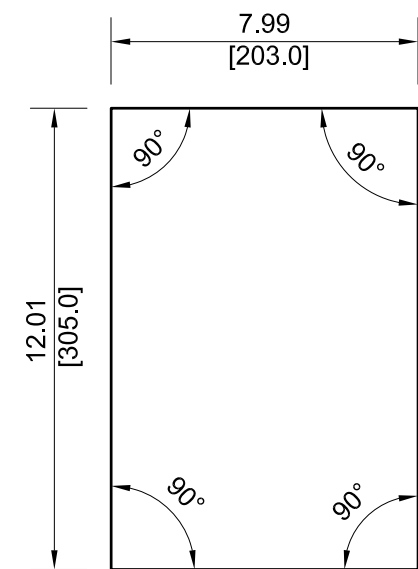
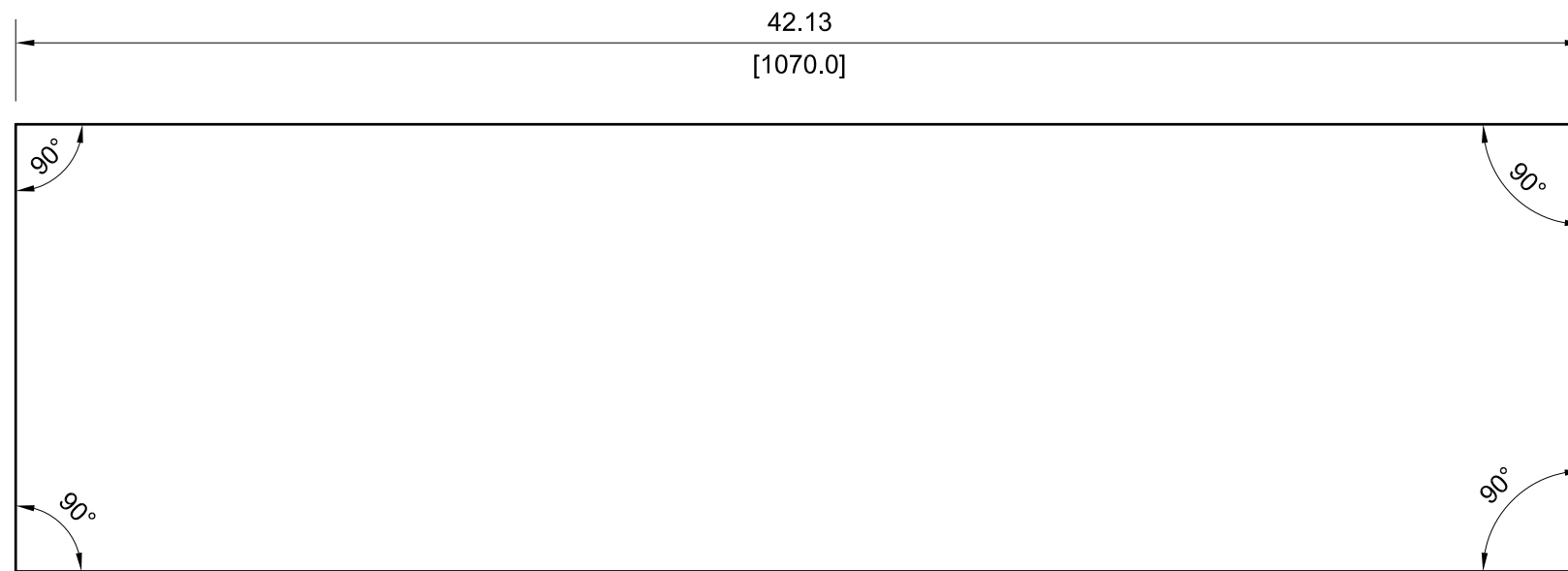
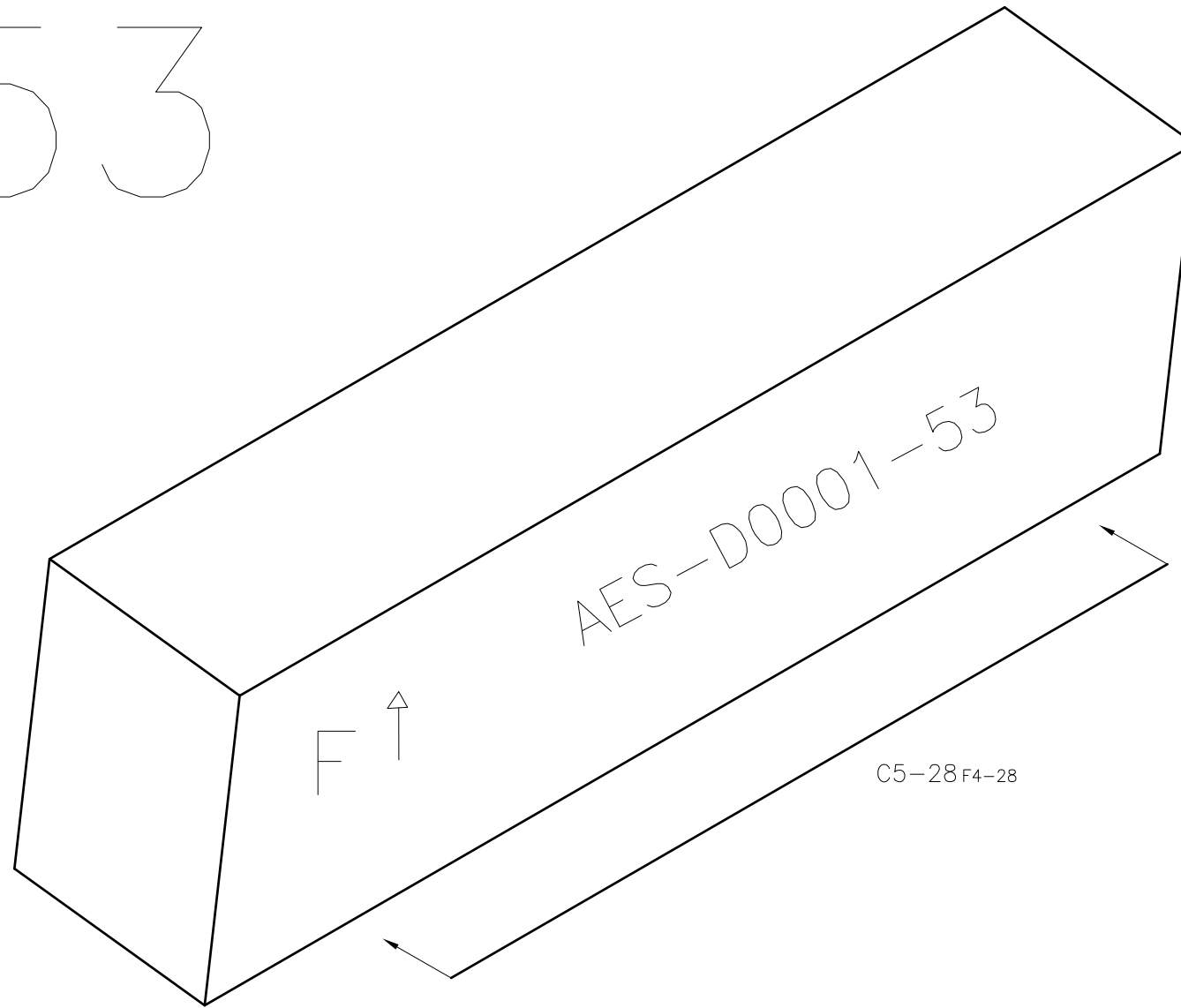

VIEW C5-28

NOTE: ALL VIEWS TAKEN AS TRUE VIEWS PARALLEL TO SURFACE OF PART



DRAWING NUMBER				
AES-D0001				
SIZE	SCALE	SHEET	OF	REVISION
A3	NONE	28	124	E

55

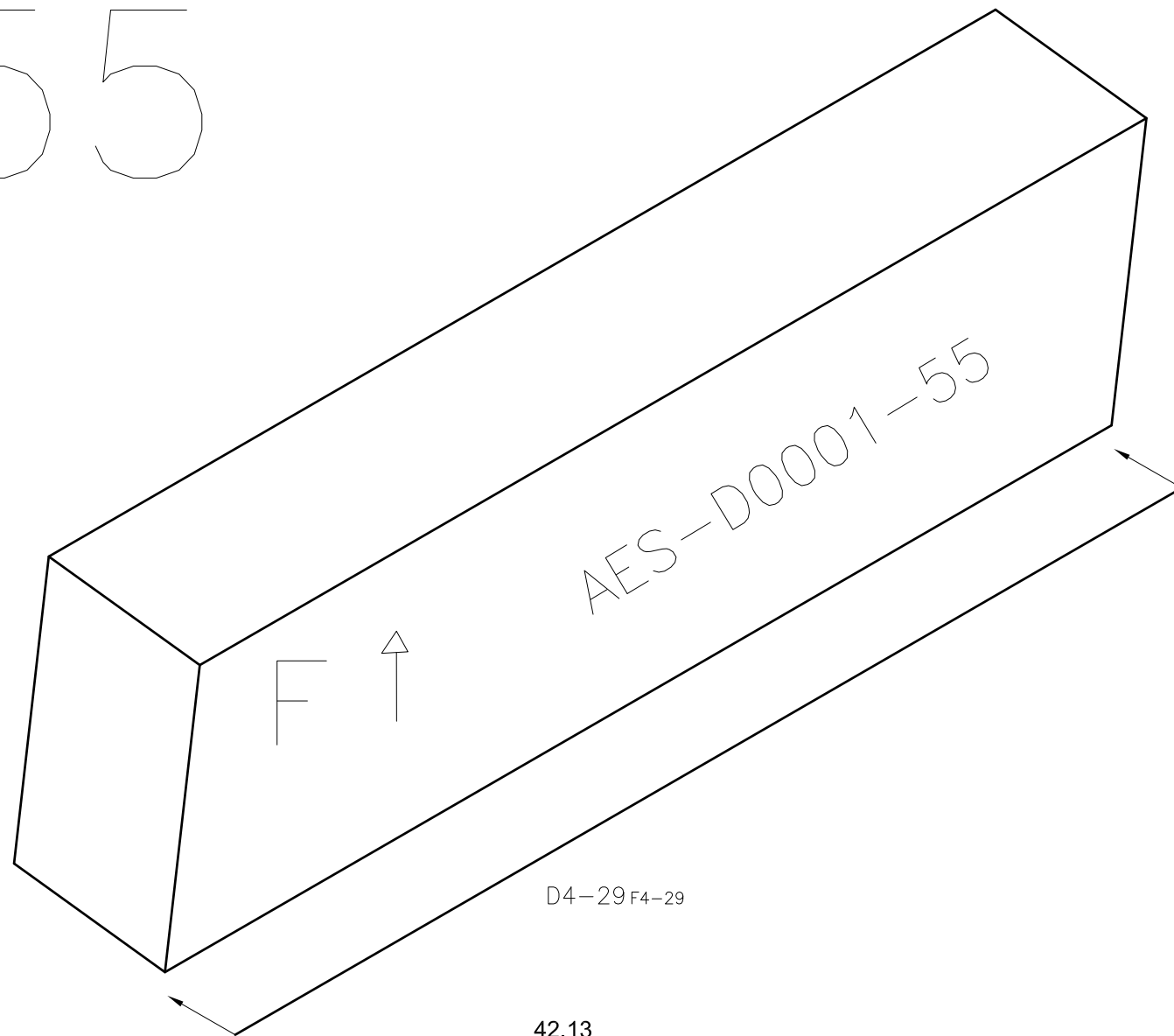

D4-29 F4-29

42.13  
[1070.0]



VIEW D4-29

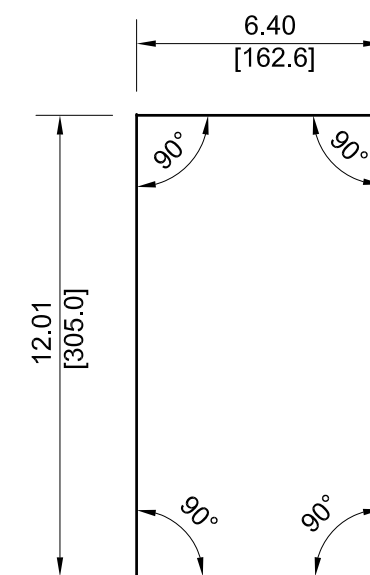

NOTE: ALL VIEWS TAKEN AS TRUE VIEWS PARALLEL TO SURFACE OF PART



DRAWING NUMBER				
AES-D0001				
SIZE	SCALE	SHEET	OF	REVISION
A3	NONE	29	124	E

— 57

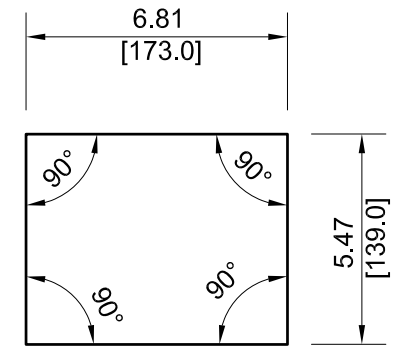
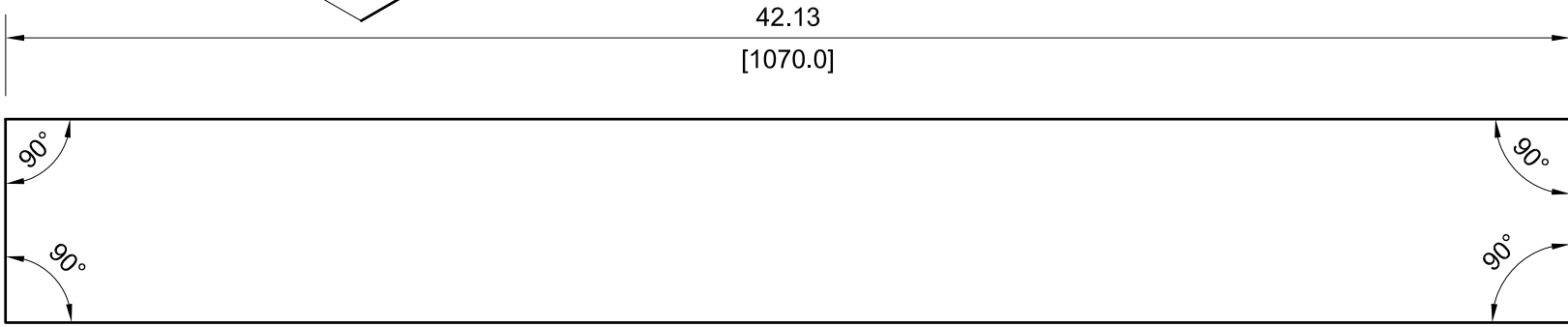
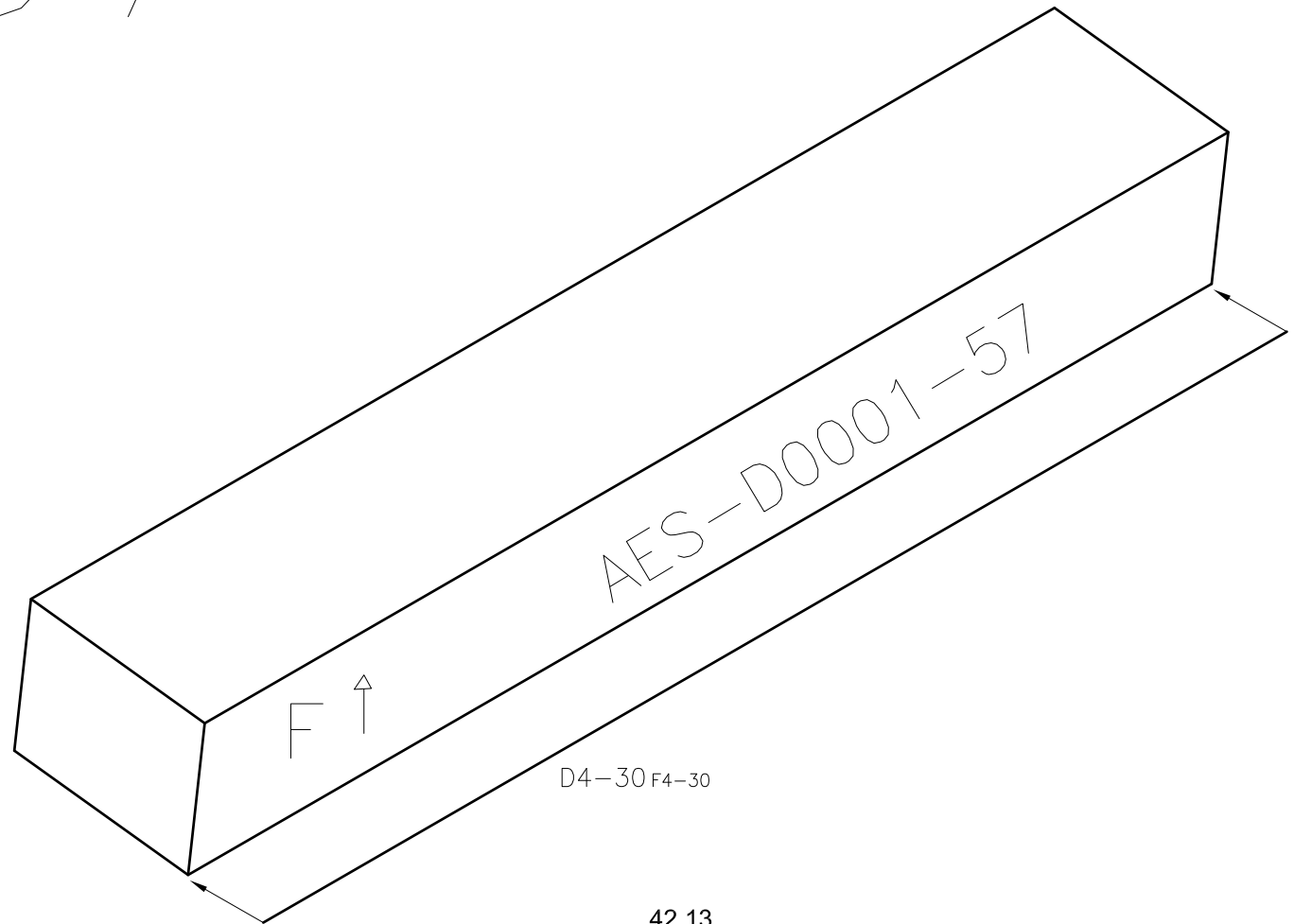

VIEW D4-30

NOTE: ALL VIEWS TAKEN AS TRUE VIEWS PARALLEL TO SURFACE OF PART

	DRAWING NUMBER				AES-D0001
	SIZE	SCALE	SHEET	OF	REVISION
A3	NONE	30	124	E	

— 59

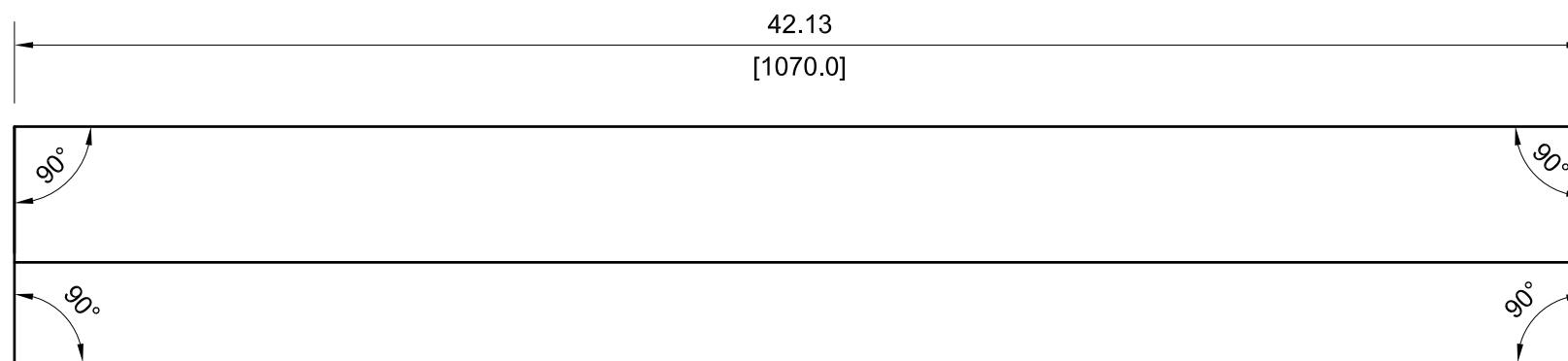
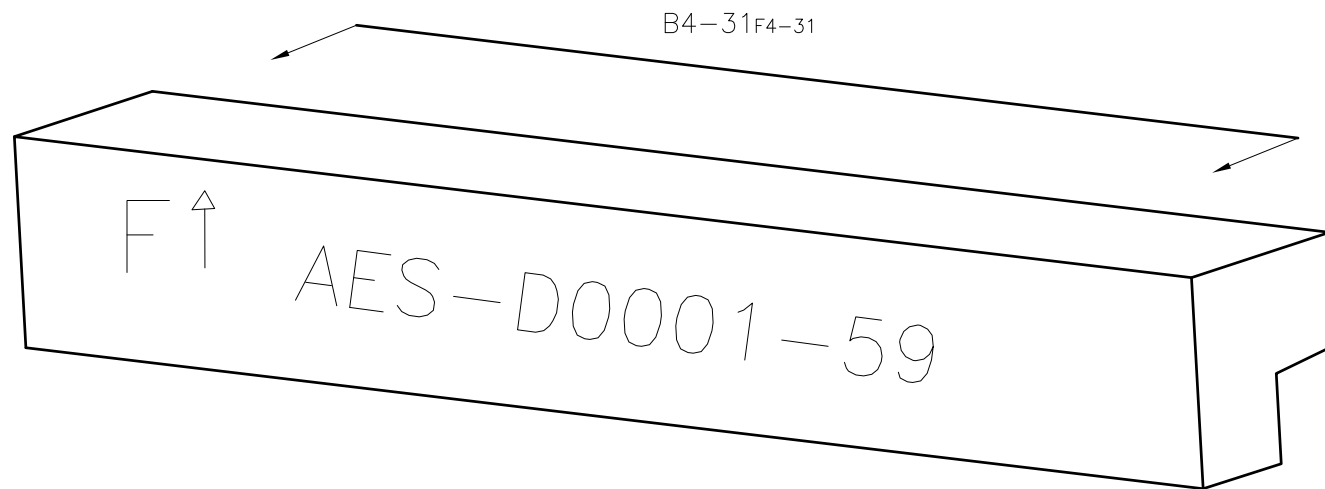

VIEW B4-31

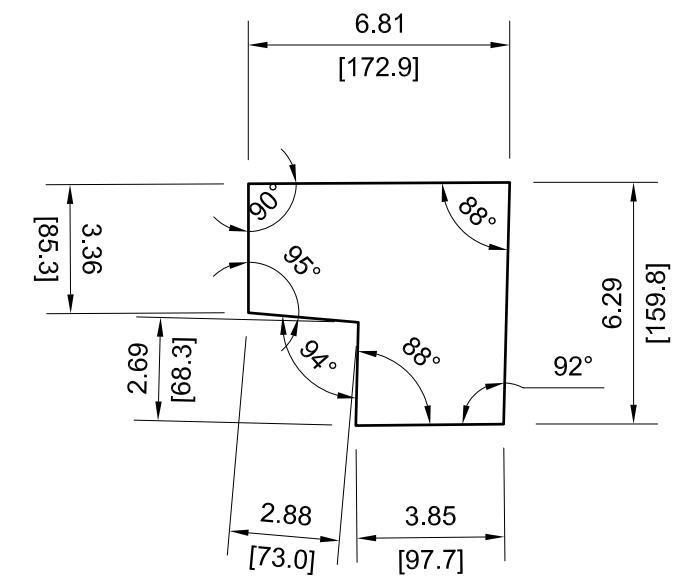

NOTE: ALL VIEWS TAKEN AS TRUE VIEWS PARALLEL TO SURFACE OF PART



DRAWING NUMBER				
AES-D0001				
SIZE	SCALE	SHEET	OF	REVISION
A3	NONE	31	124	E

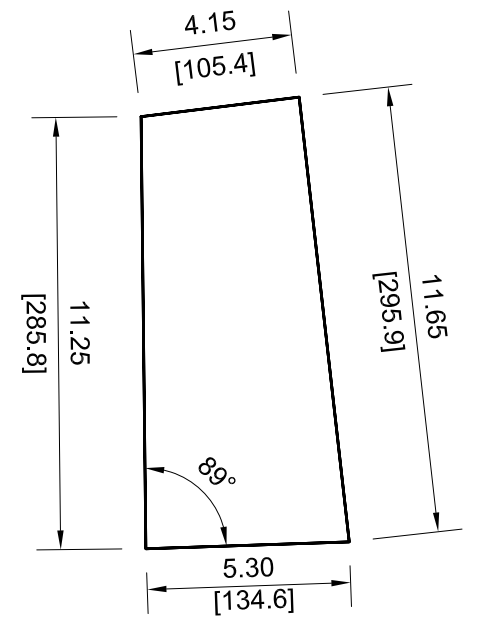
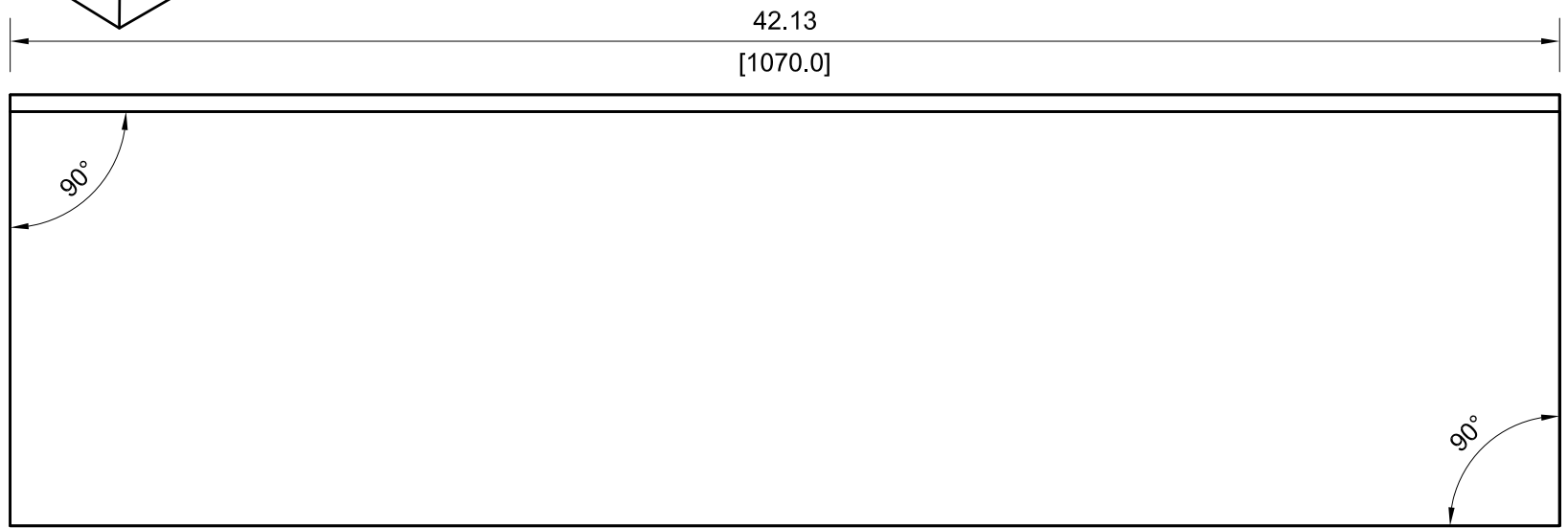
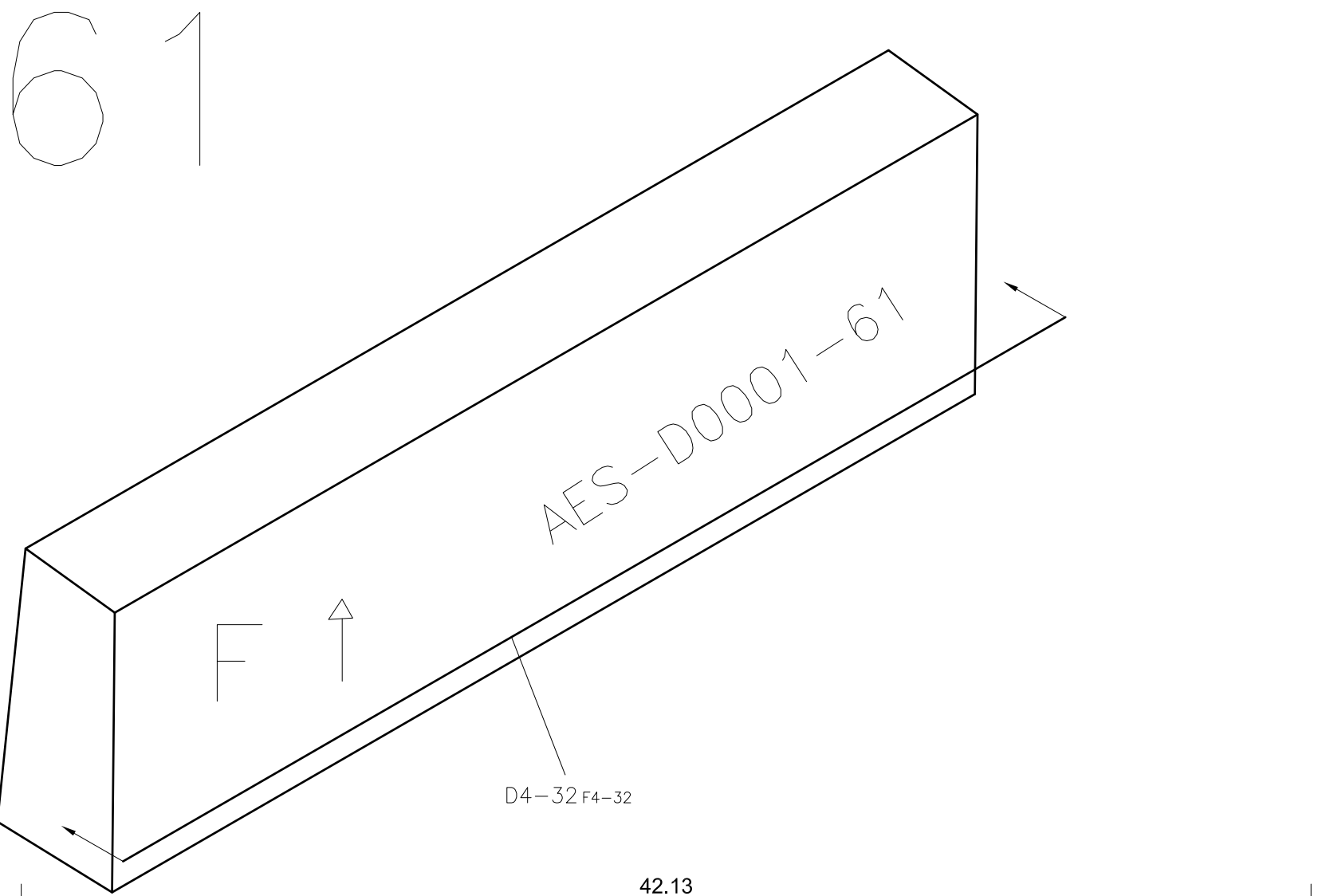

NOTE: ALL VIEWS TAKEN AS TRUE VIEWS PARALLEL TO SURFACE OF PART

	DRAWING NUMBER			
	AES-D0001			
SIZE	SCALE	SHEET	OF	REVISION
A3	NONE	32	124	E

— 63

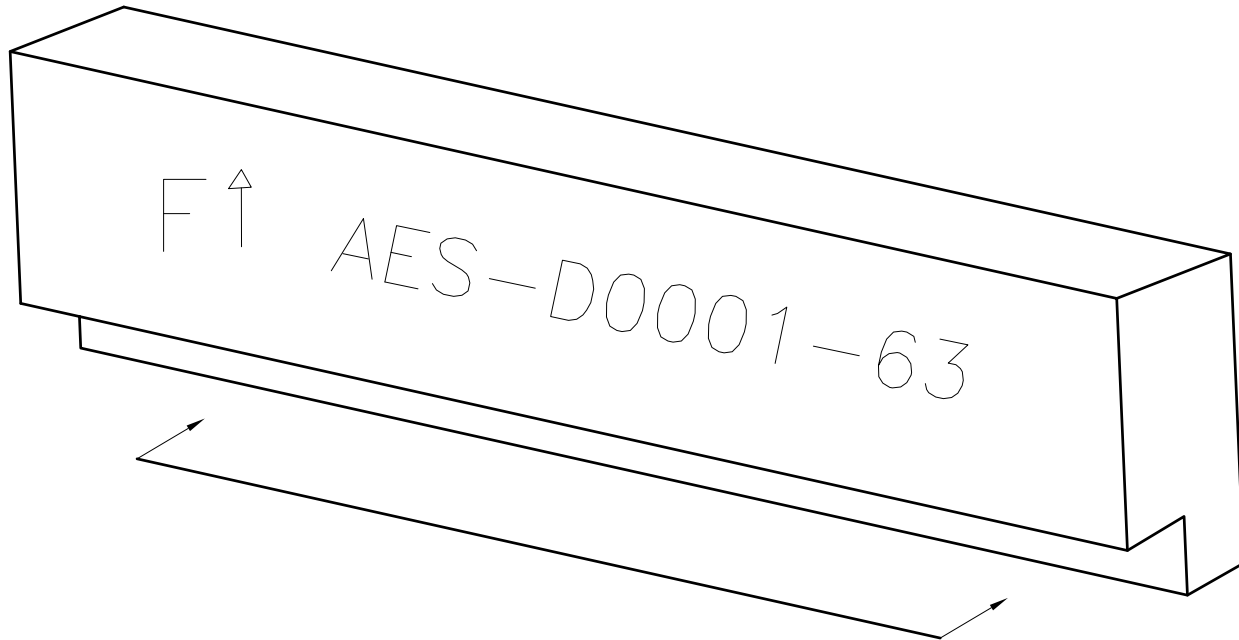

D4-33 F4-33

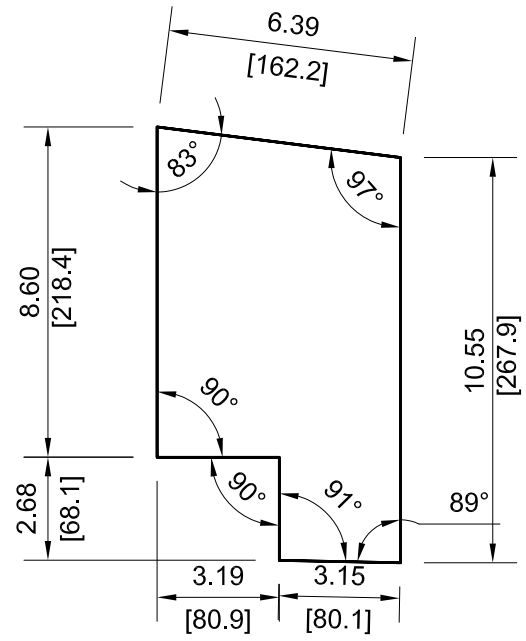
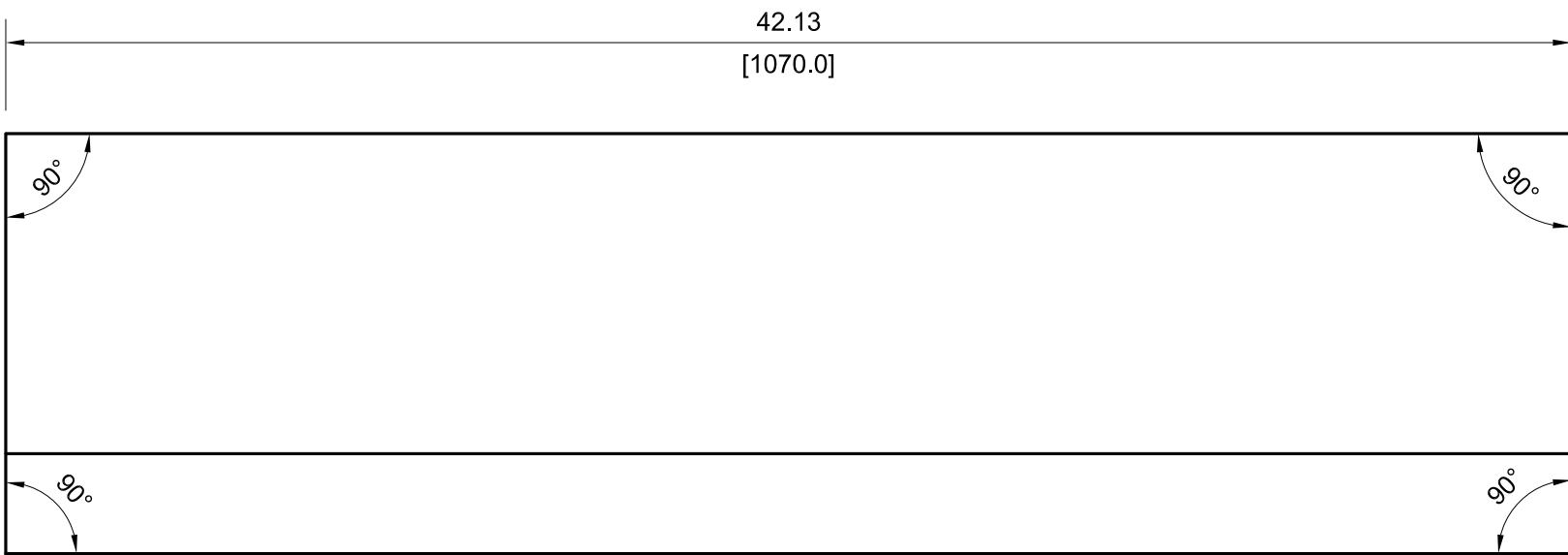

VIEW D4-33

NOTE: ALL VIEWS TAKEN AS TRUE VIEWS PARALLEL TO SURFACE OF PART

	DRAWING NUMBER				AES-D0001	
	SIZE	SCALE	SHEET	OF	REVISION	
A3	NONE	33	124	E		

65

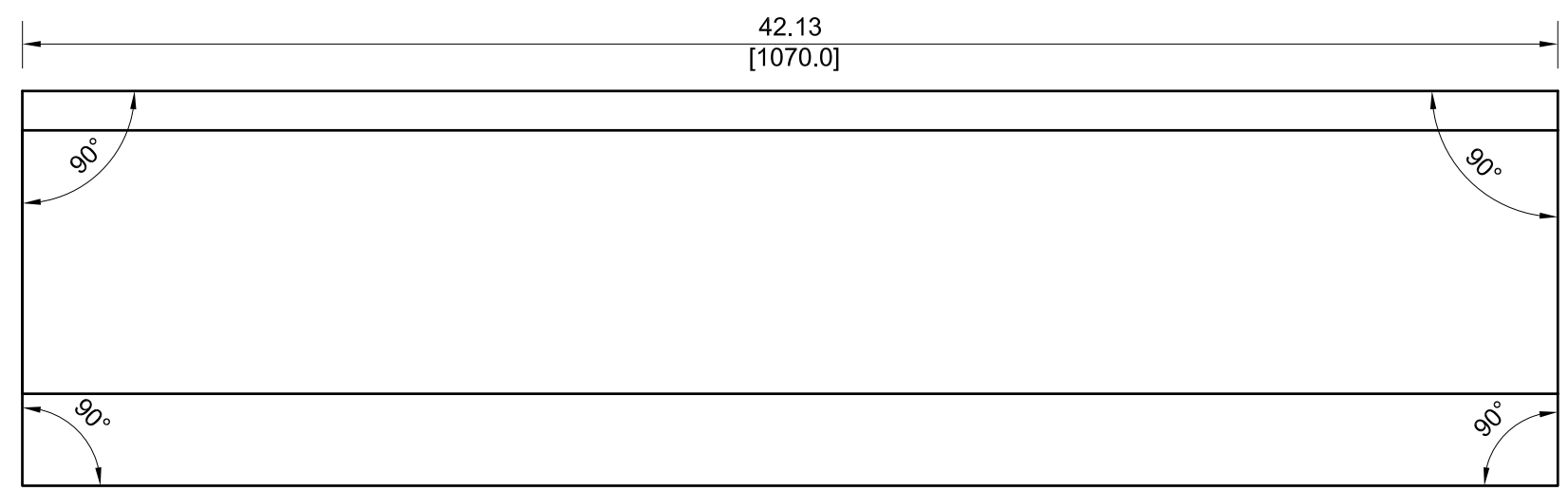
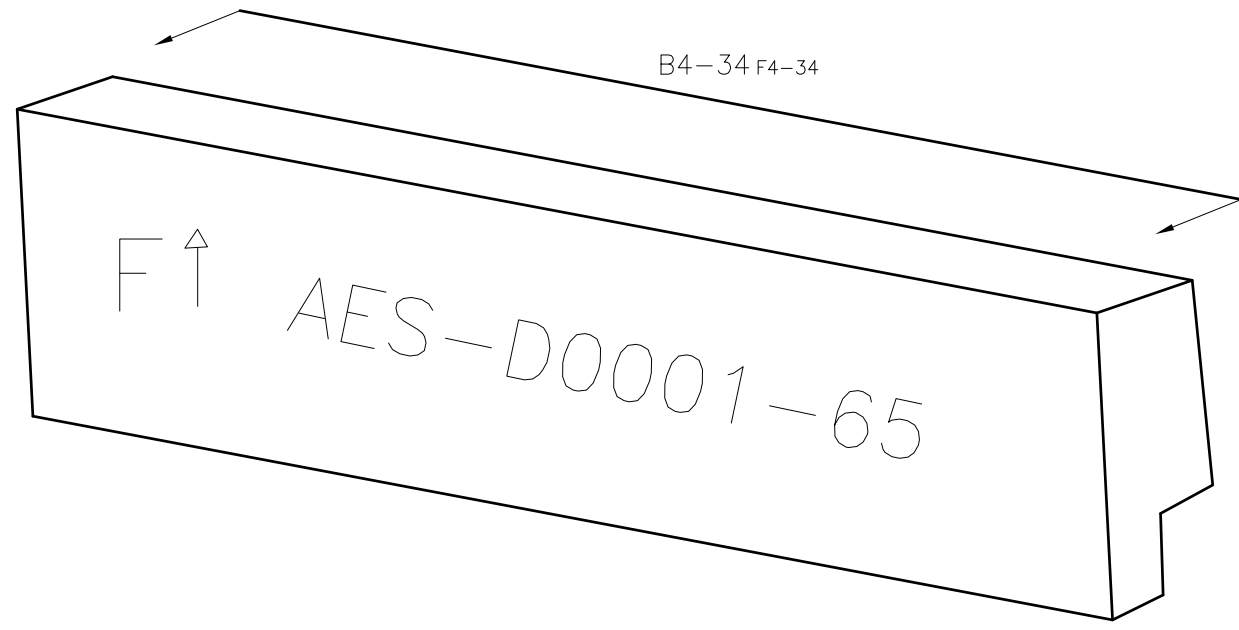

VIEW B4-34

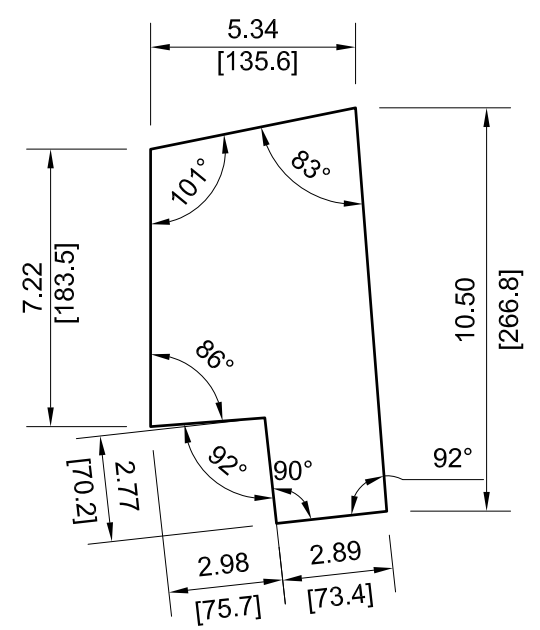

NOTE: ALL VIEWS TAKEN AS TRUE VIEWS PARALLEL TO SURFACE OF PART

	DRAWING NUMBER				AES-D0001
	SIZE	SCALE	SHEET	OF	REVISION
A3	NONE	34	124	E	

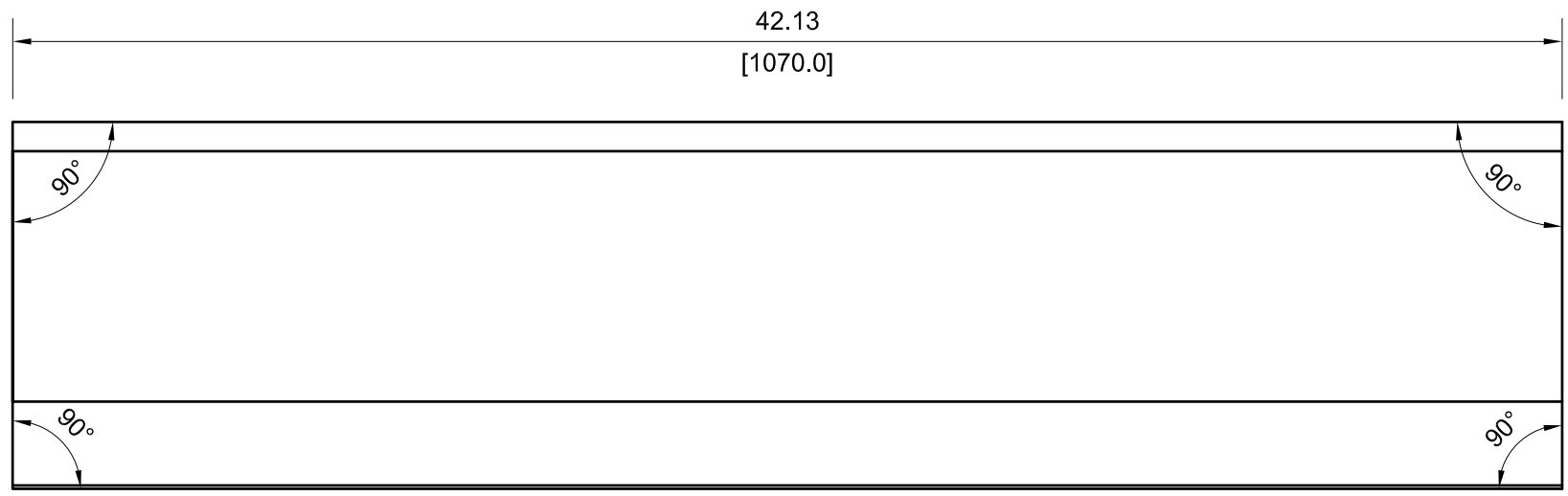
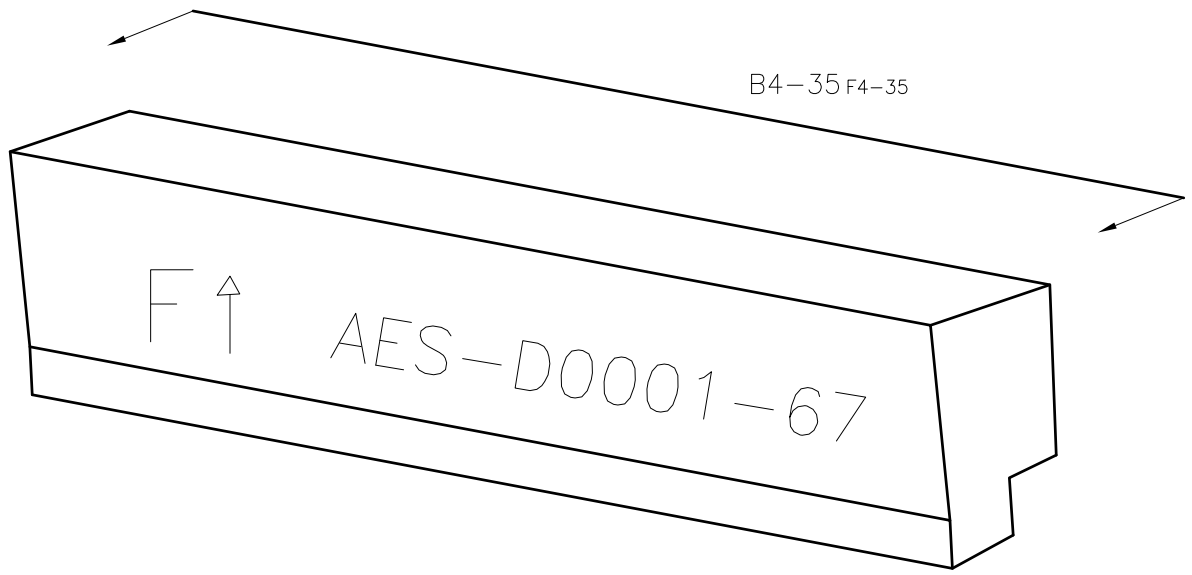
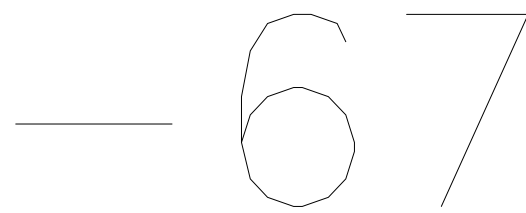

VIEW B4-35

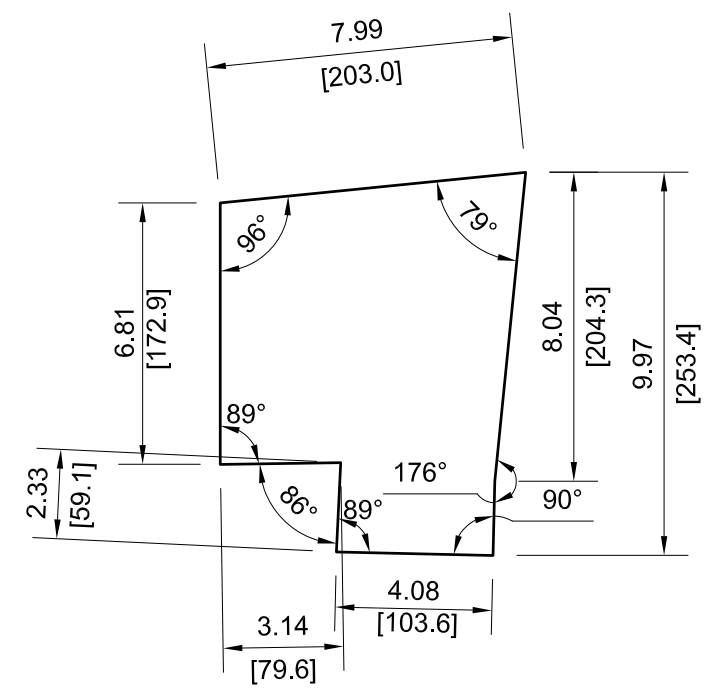

NOTE: ALL VIEWS TAKEN AS TRUE VIEWS PARALLEL TO SURFACE OF PART

	DRAWING NUMBER				AES-D0001
	SIZE	SCALE	SHEET	OF	REVISION
A3	NONE	35	124	E	

69

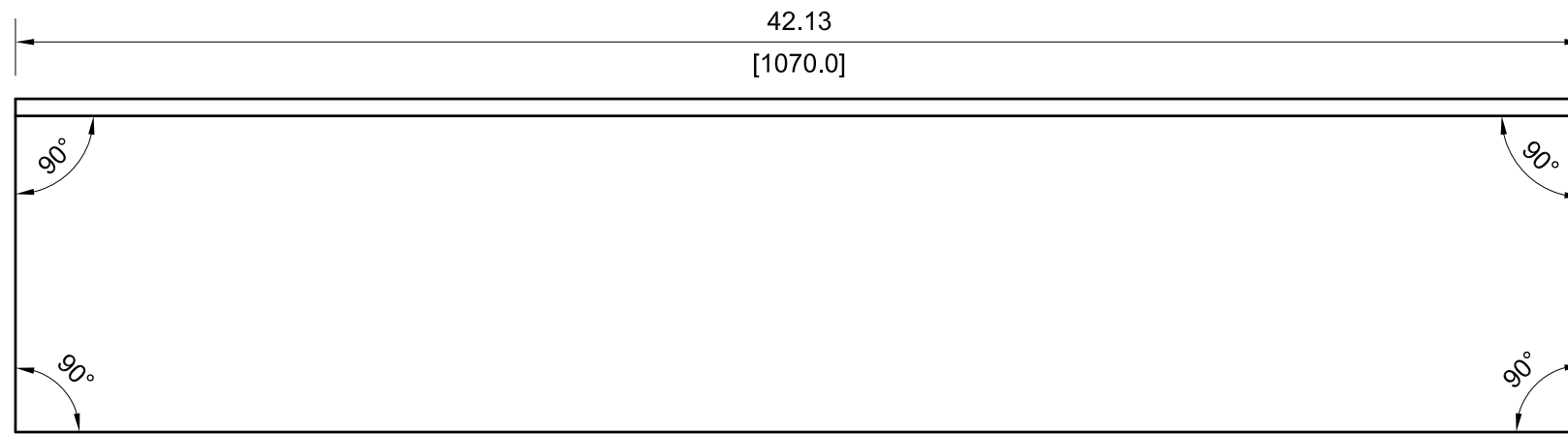
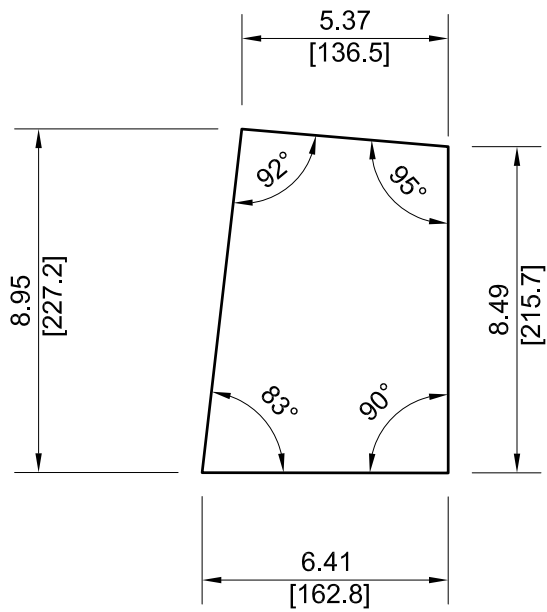

VIEW B4-36

NOTE: ALL VIEWS TAKEN AS TRUE VIEWS PARALLEL TO SURFACE OF PART



DRAWING NUMBER					AES-D0001	
SIZE	SCALE	SHEET	OF	REVISION		
A3	NONE	36	124	E		

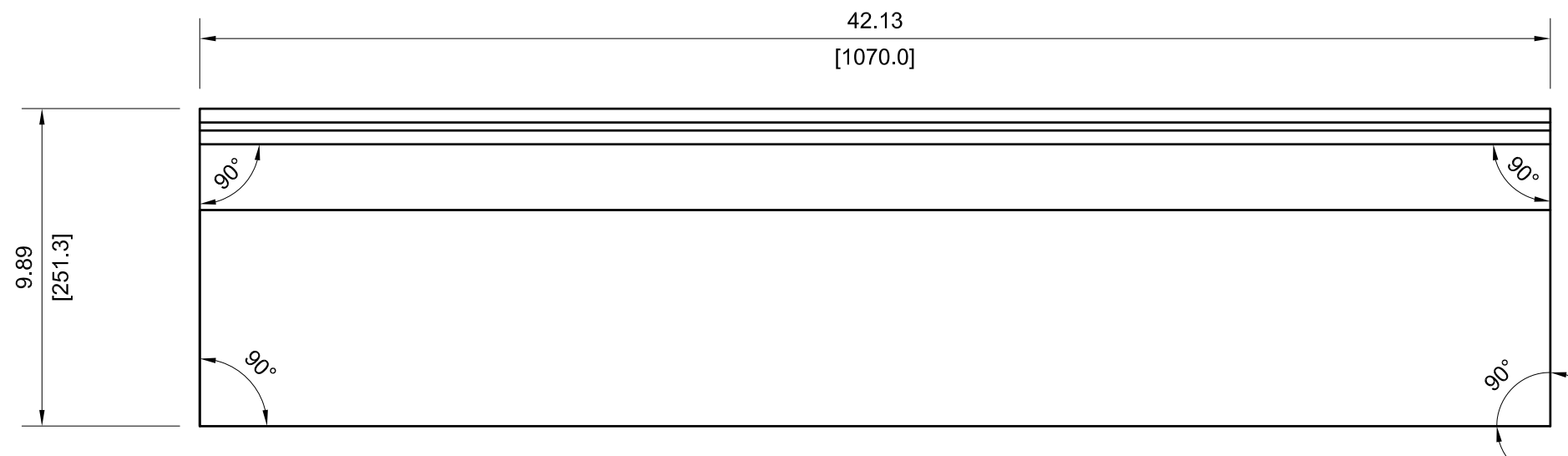
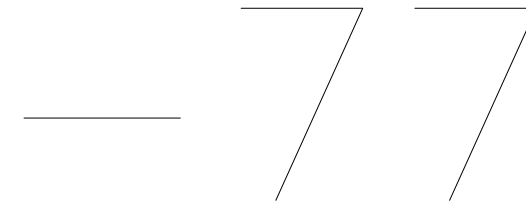

VIEW A4-37

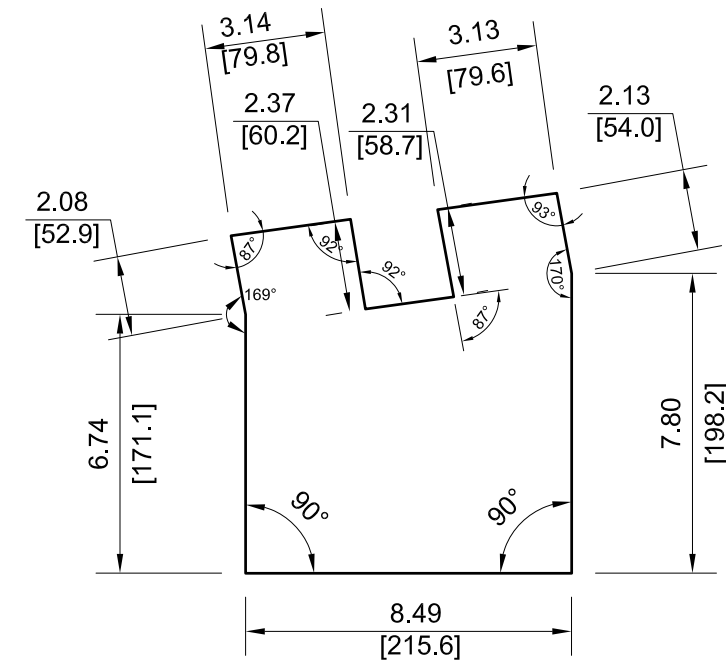

NOTE: ALL VIEWS TAKEN AS TRUE VIEWS PARALLEL TO SURFACE OF PART



DRAWING NUMBER					AES-D0001	
SIZE	SCALE	SHEET	OF	REVISION		
A3	NONE	37	124	E		

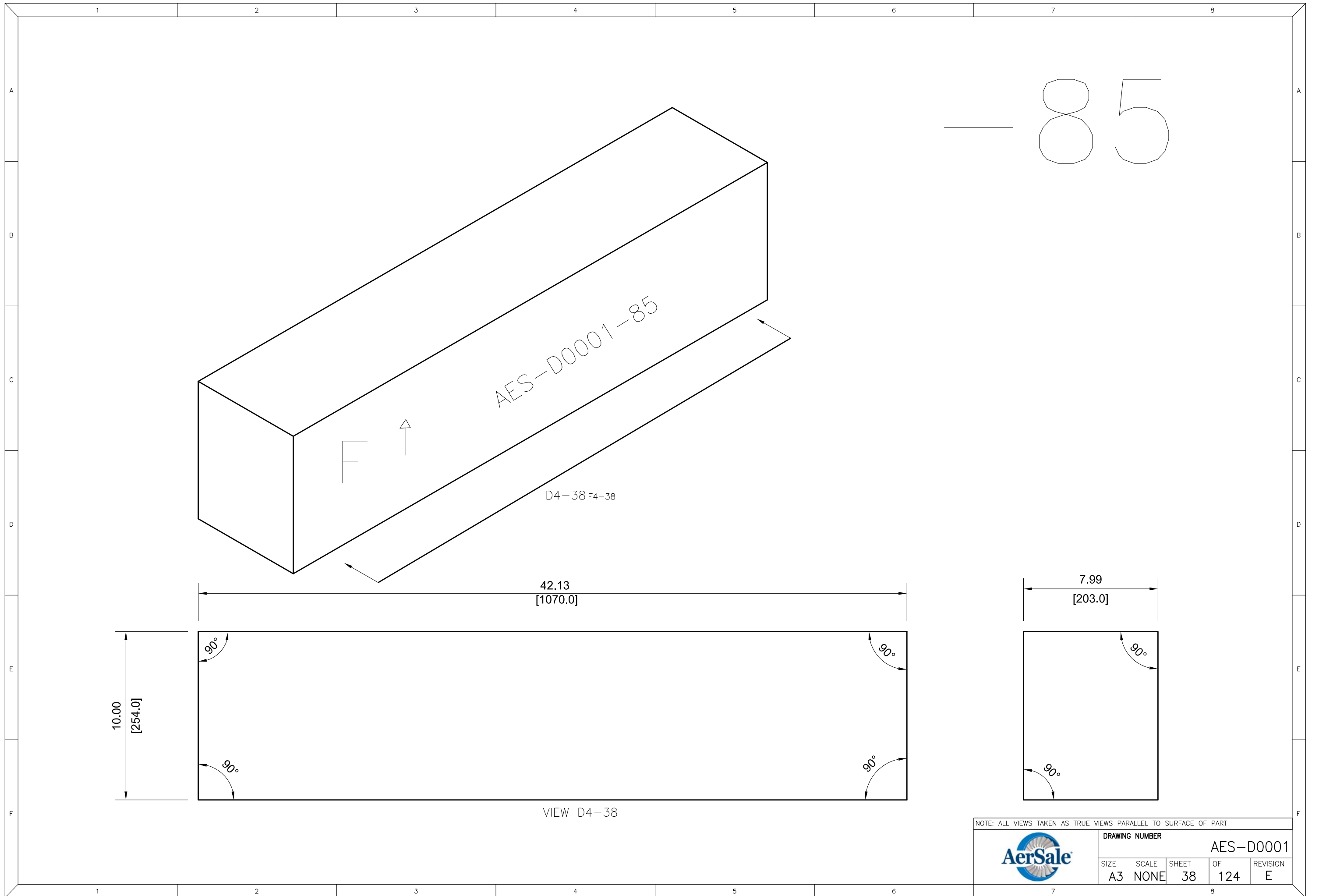

— 85

AES-D0001-85

F ↑

D4-38 F4-38

42.13  
[1070.0]

10.00  
[254.0]



VIEW D4-38

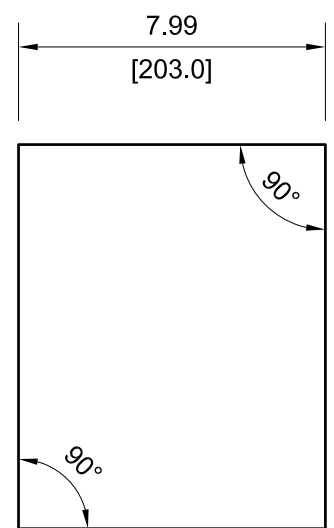

NOTE: ALL VIEWS TAKEN AS TRUE VIEWS PARALLEL TO SURFACE OF PART

	DRAWING NUMBER				
	AES-D0001				
SIZE	SCALE	SHEET	OF	REVISION	
A3	NONE	38	124	E	

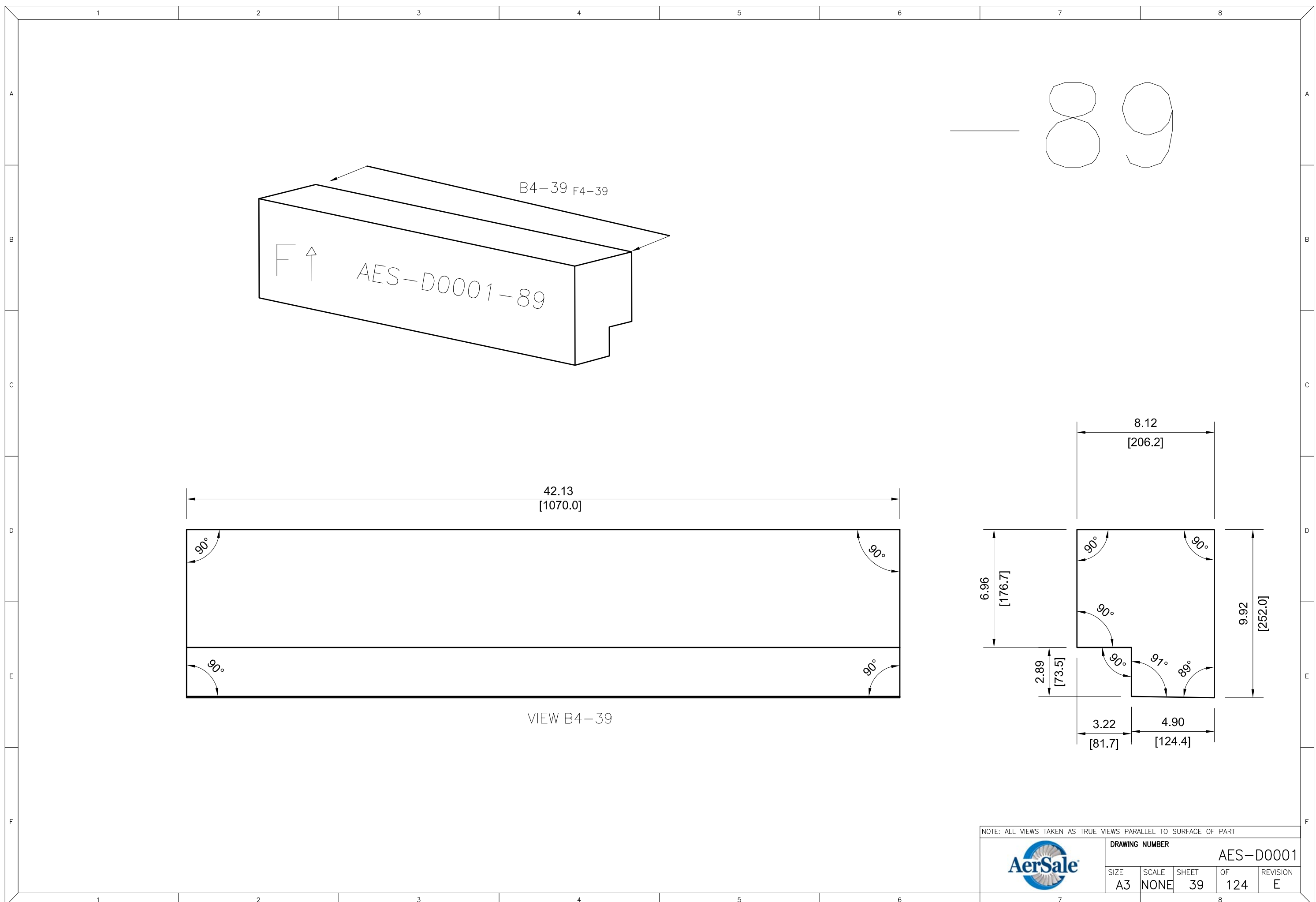

NOTE: ALL VIEWS TAKEN AS TRUE VIEWS PARALLEL TO SURFACE OF PART

		DRAWING NUMBER			
		AES-D0001			
SIZE	SCALE	SHEET	OF	REVISION	
A3	NONE	39	124	E	

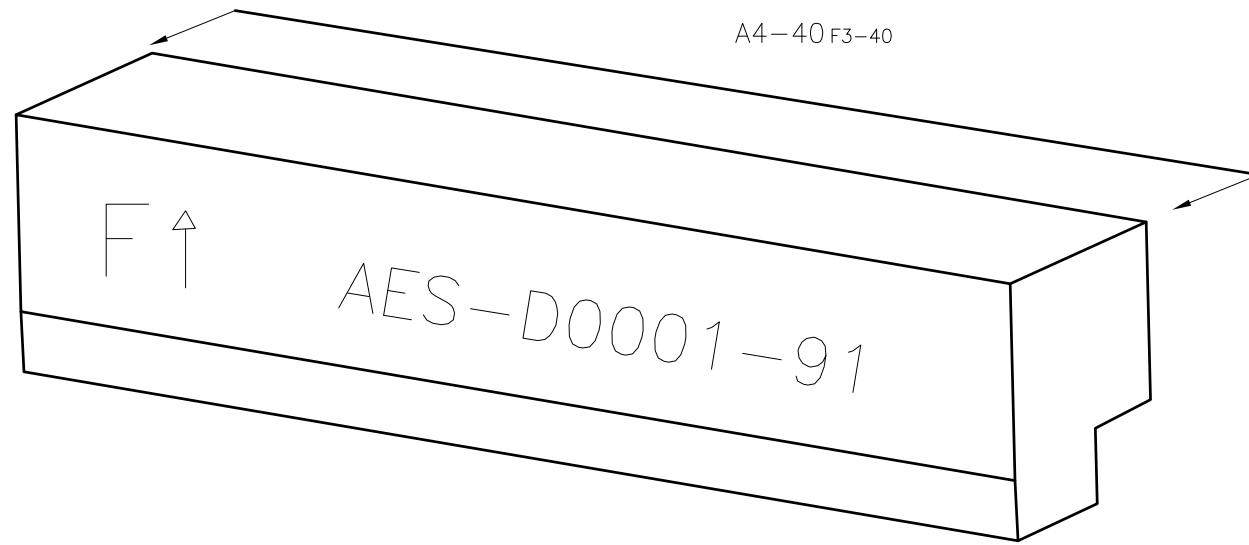

— 91

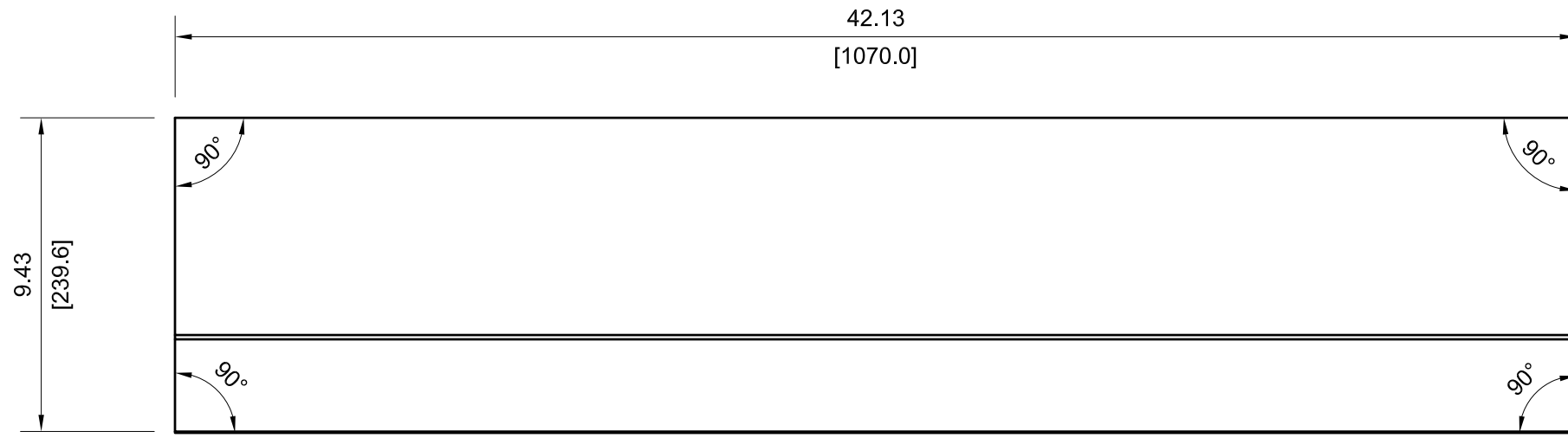

VIEW A4-40

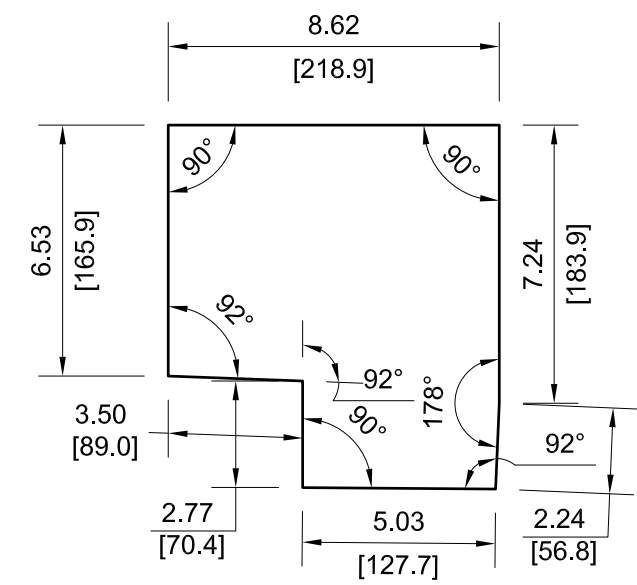

NOTE: ALL VIEWS TAKEN AS TRUE VIEWS PARALLEL TO SURFACE OF PART

	DRAWING NUMBER				
	AES-D0001				
SIZE	SCALE	SHEET	OF	REVISION	
A3	NONE	40	124	E	

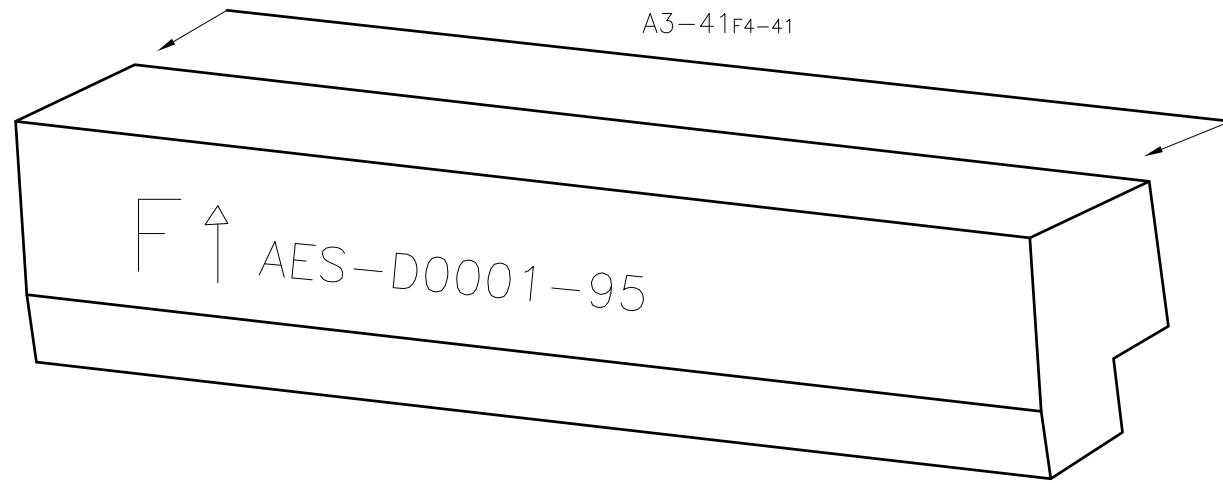

— 95

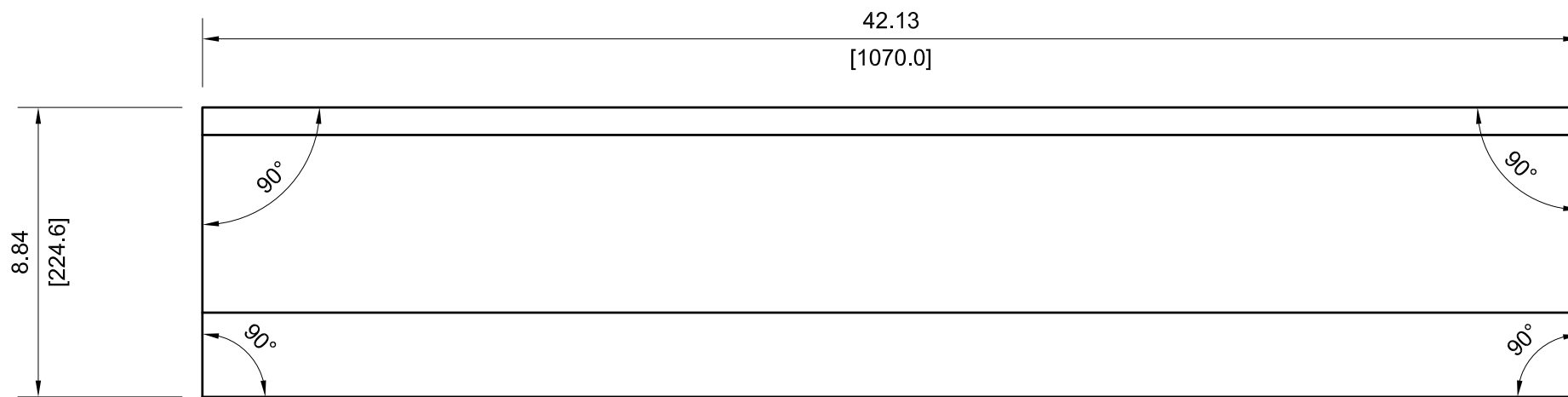

VIEW A3-41

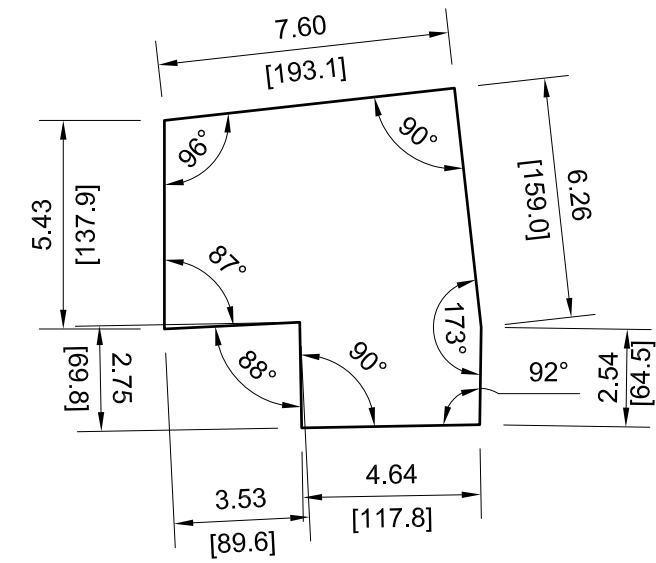

NOTE: ALL VIEWS TAKEN AS TRUE VIEWS PARALLEL TO SURFACE OF PART



DRAWING NUMBER					AES-D0001	
SIZE	SCALE	SHEET	OF	REVISION		
A3	NONE	41	124	E		

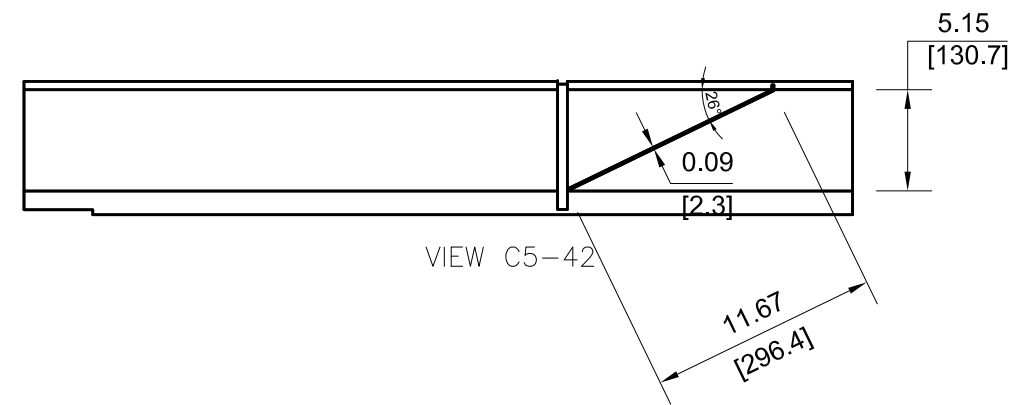
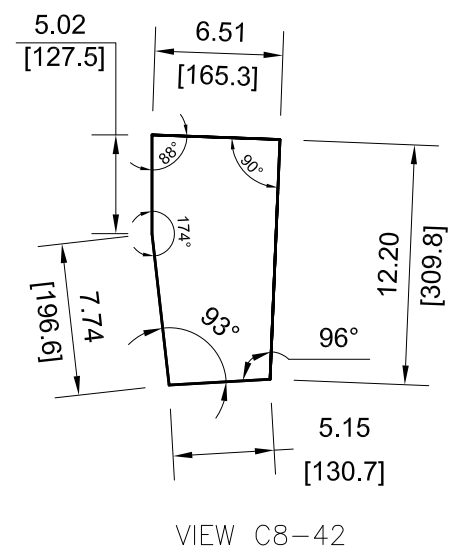
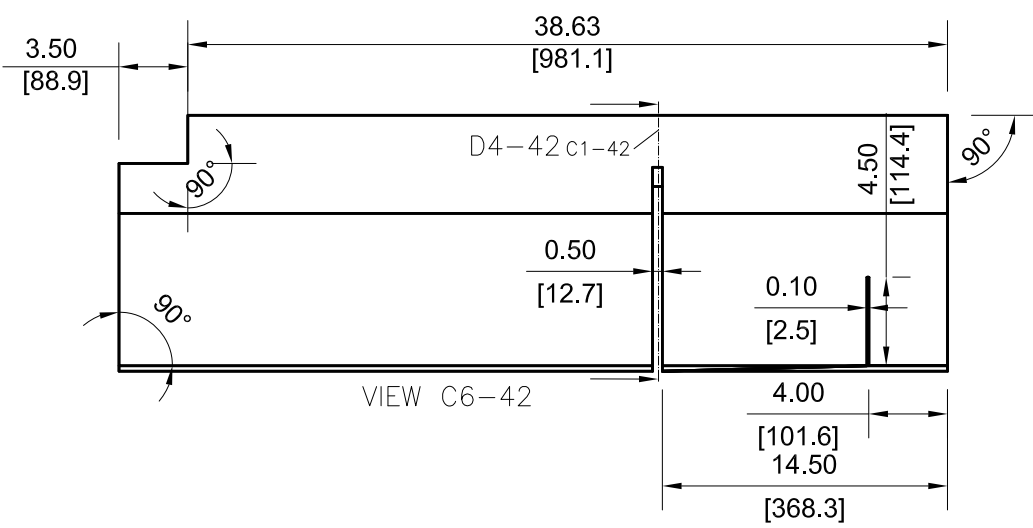
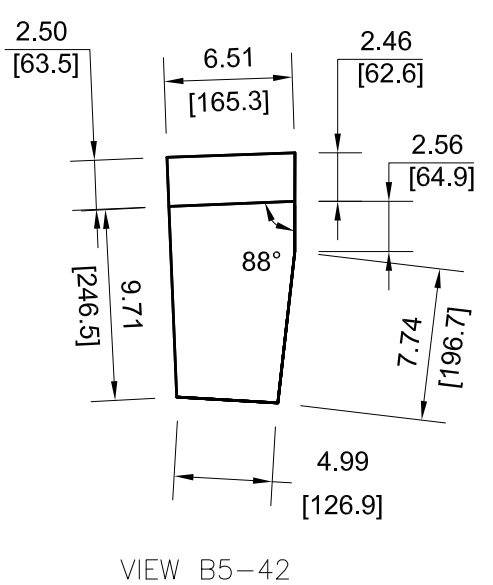
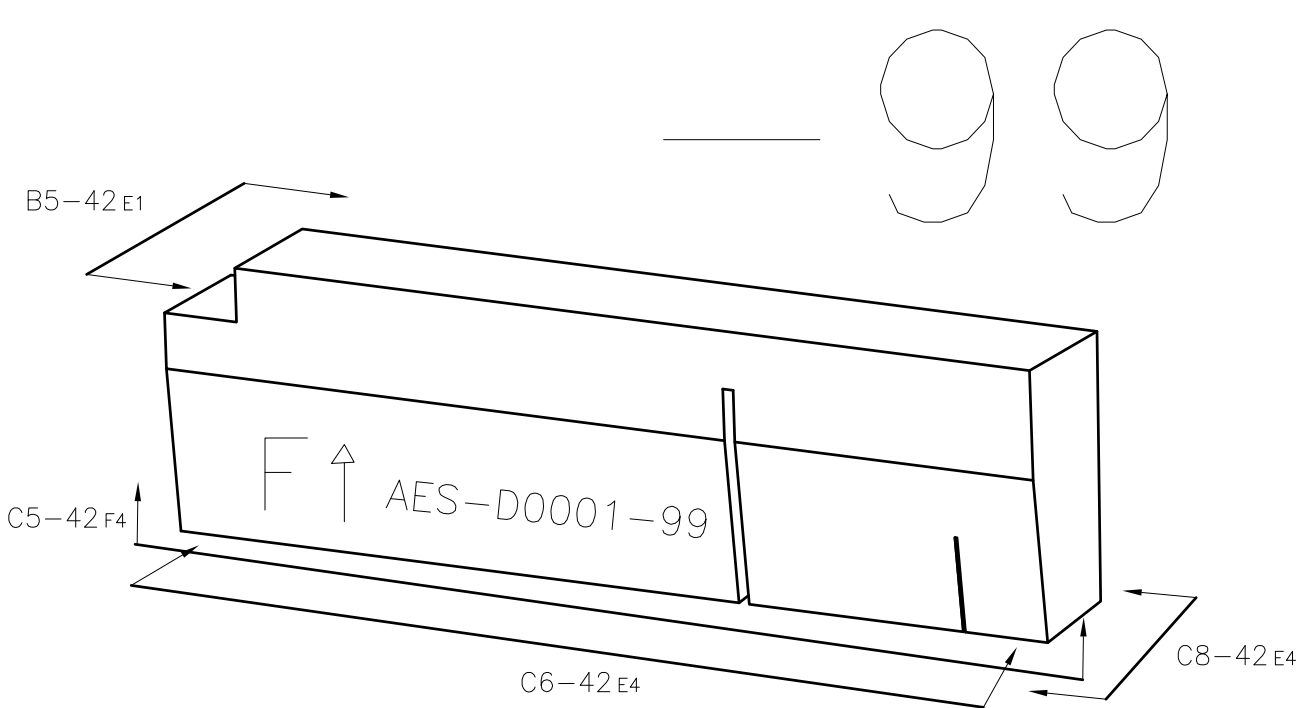
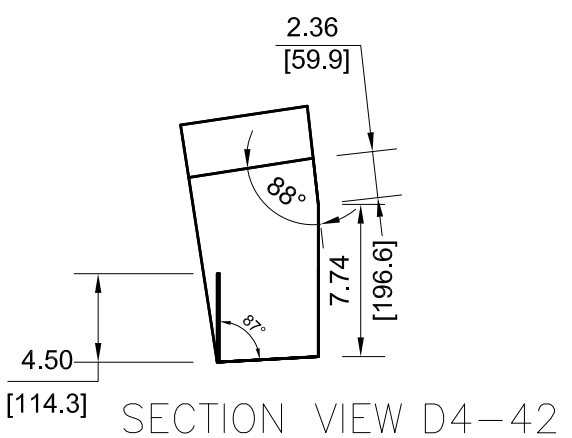
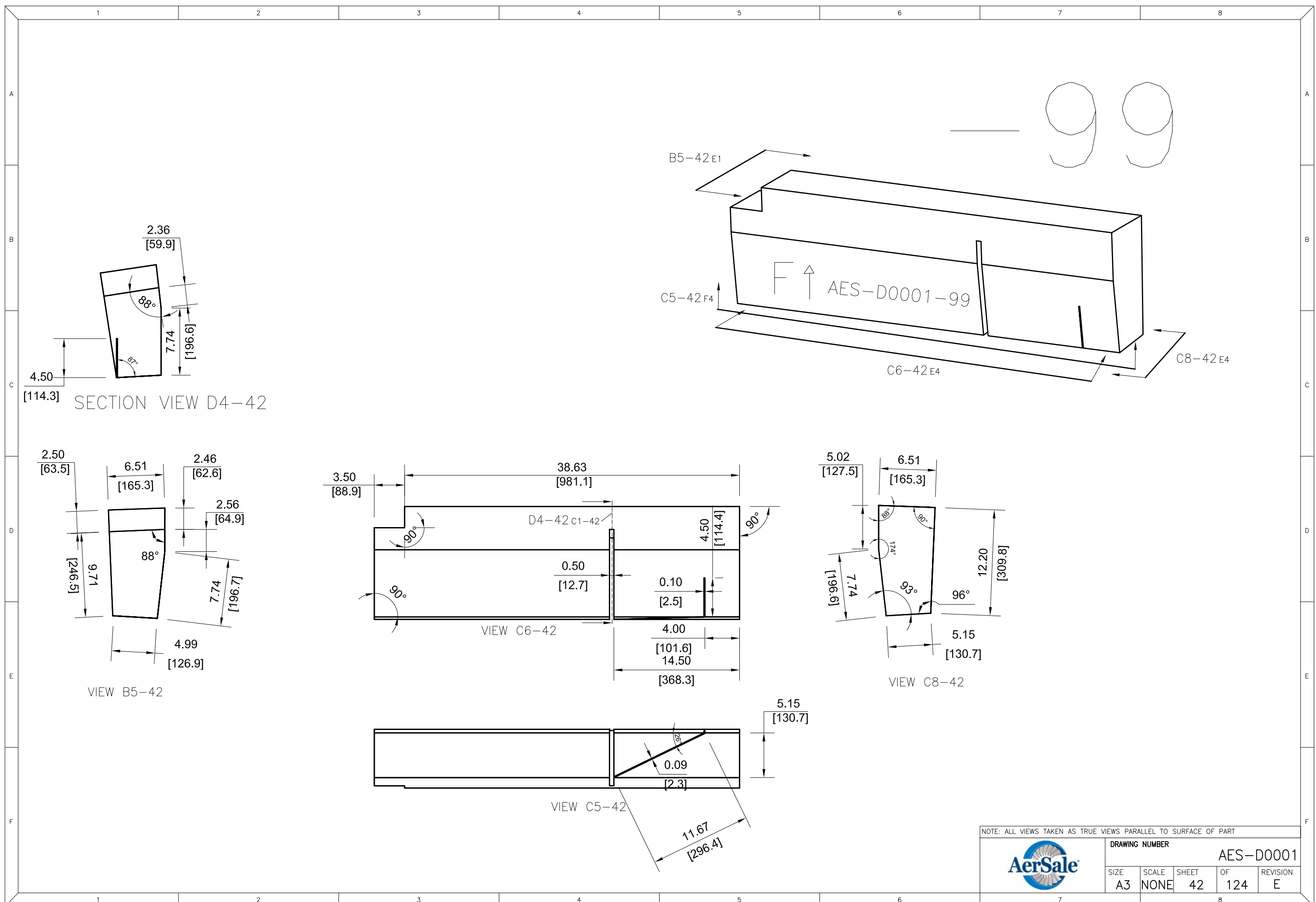

NOTE: ALL VIEWS TAKEN AS TRUE VIEWS PARALLEL TO SURFACE OF PART

		DRAWING NUMBER			
		AES-D0001			
SIZE	SCALE	SHEET	OF	REVISION	
A3	NONE	42	124	E	

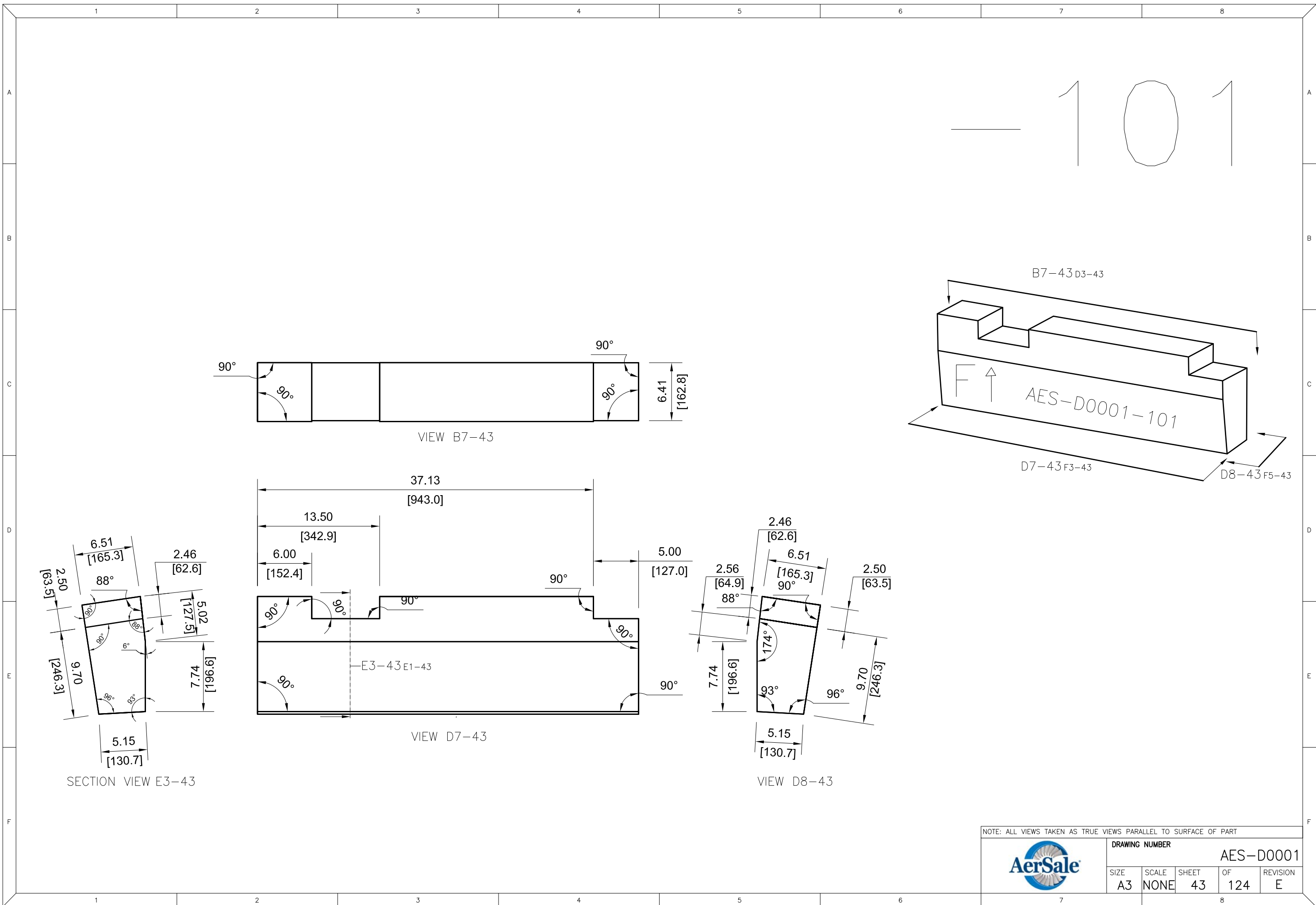

103

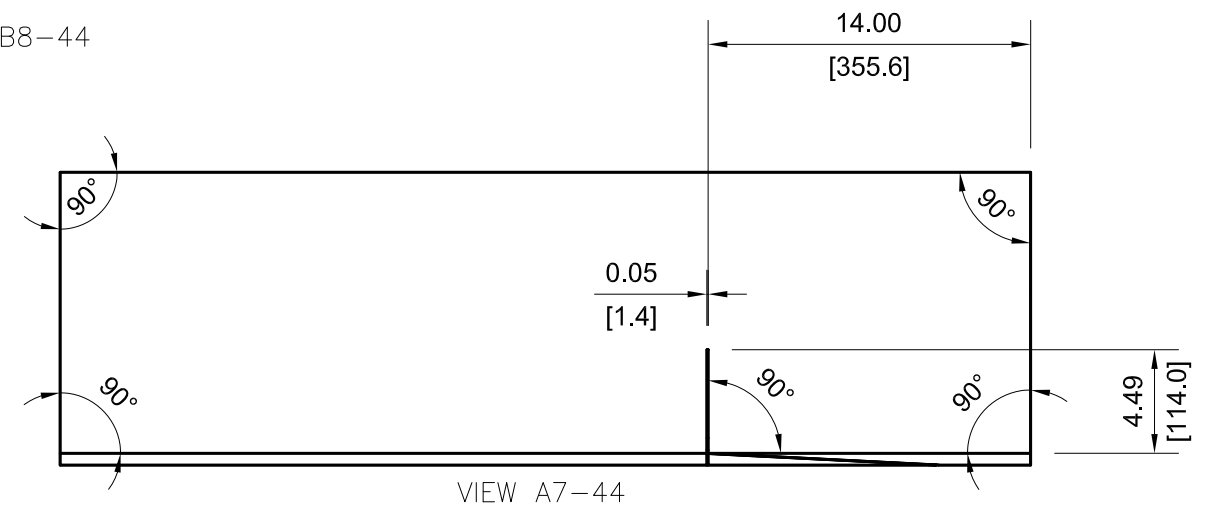
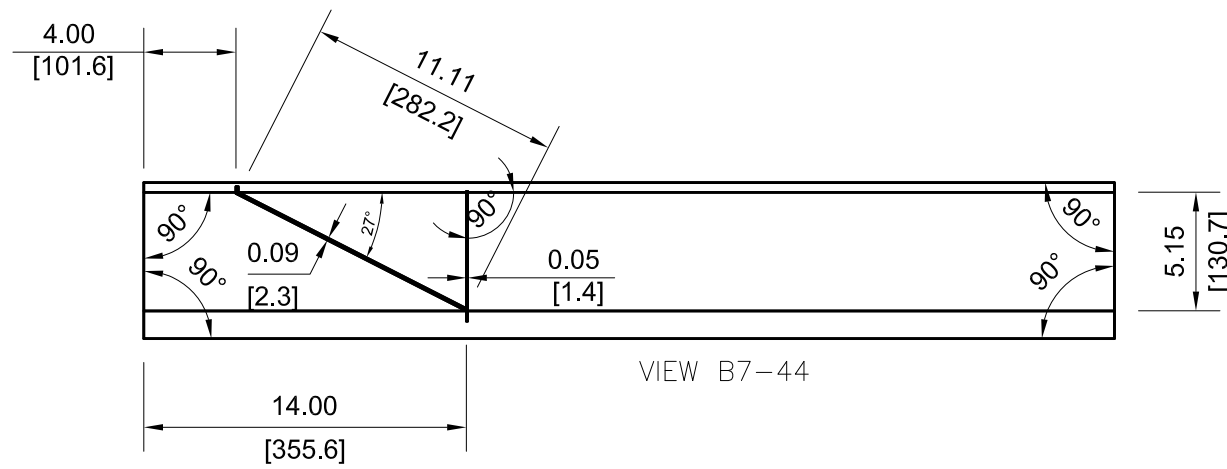
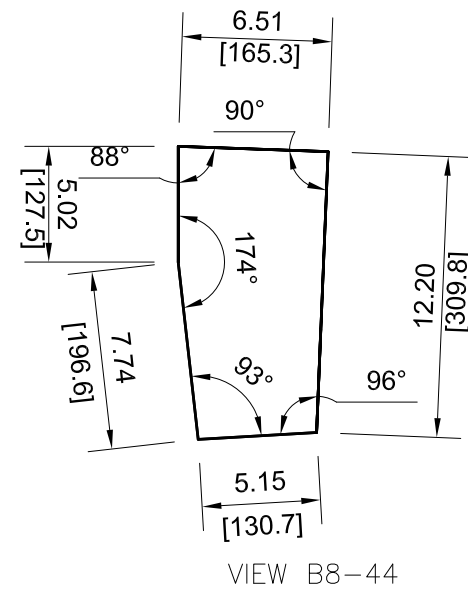
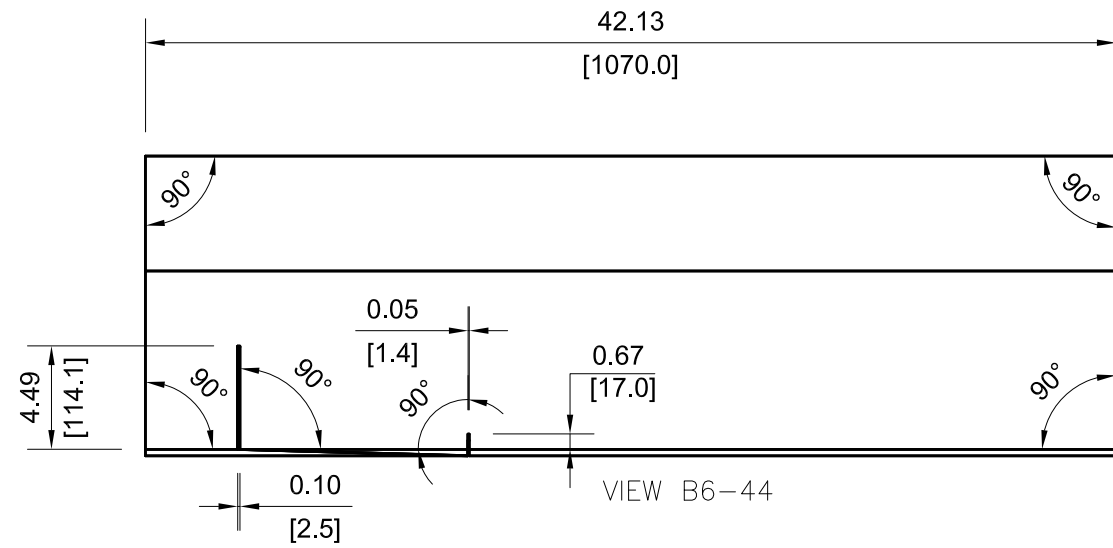
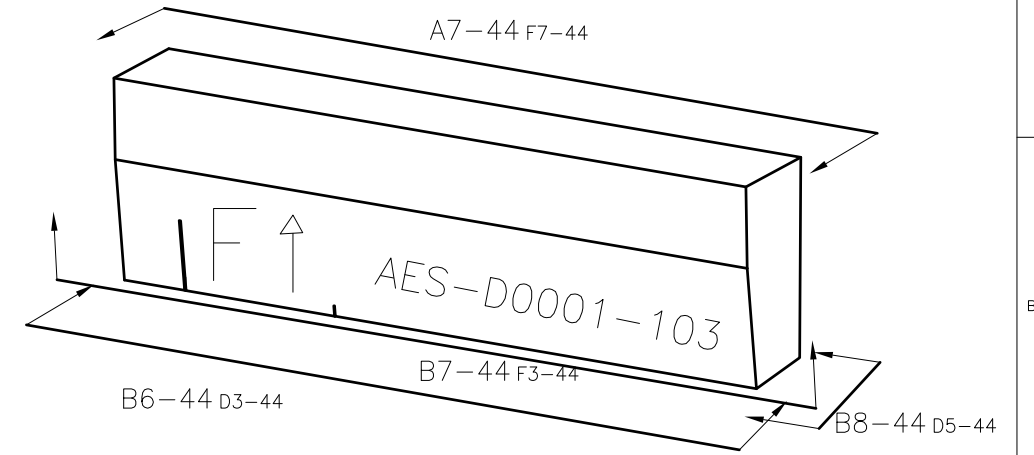

NOTE: ALL VIEWS TAKEN AS TRUE VIEWS PARALLEL TO SURFACE OF PART

		DRAWING NUMBER			
		AES-D0001			
SIZE	SCALE	SHEET	OF	REVISION	
A3	NONE	44	124	E	

105

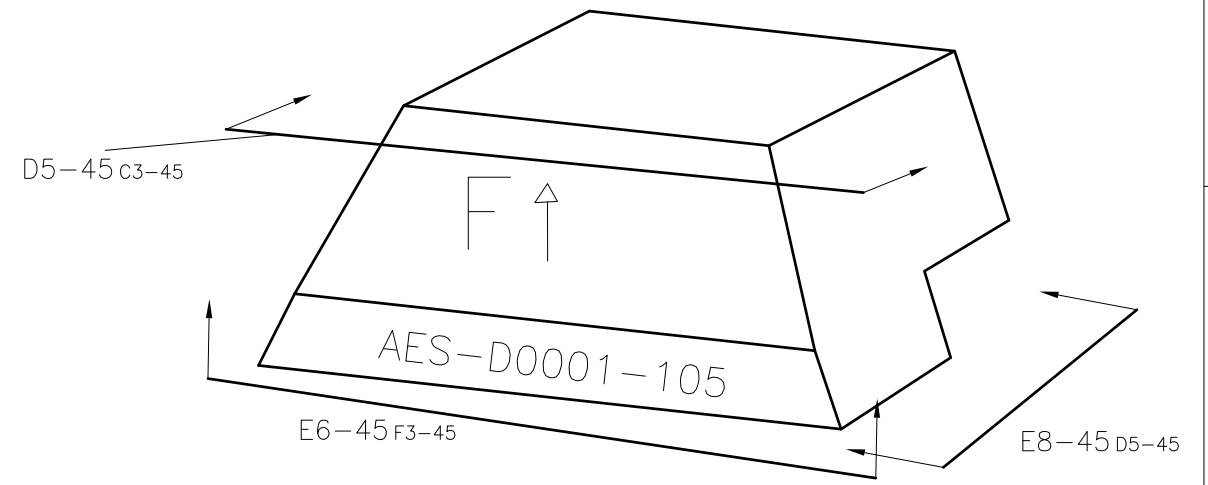
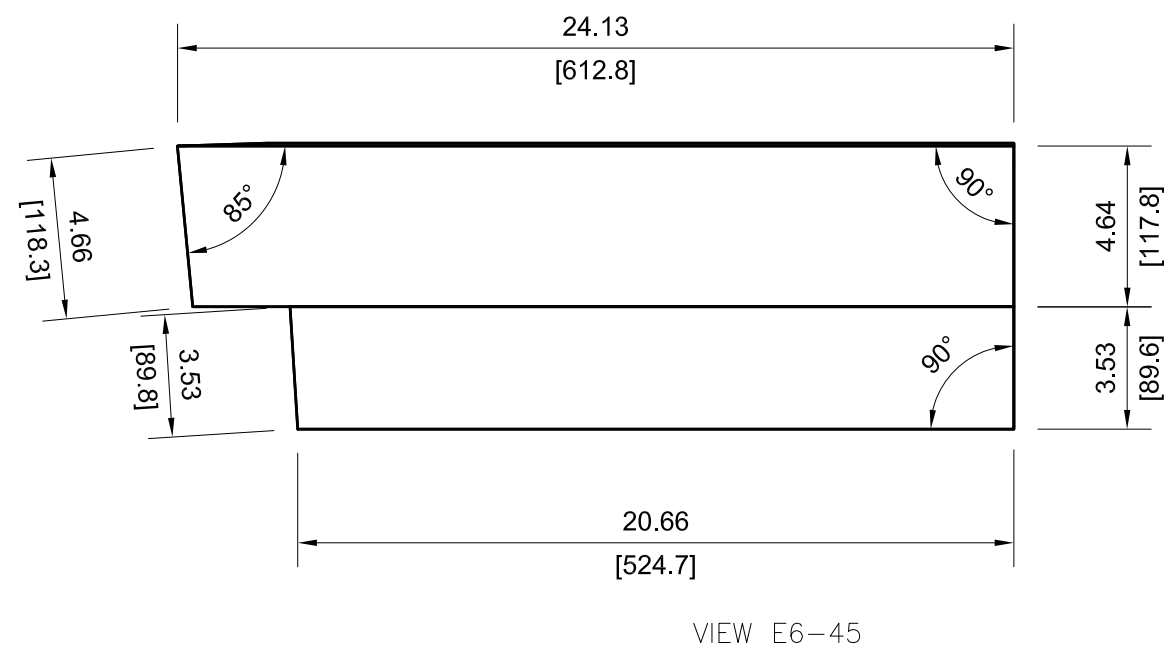
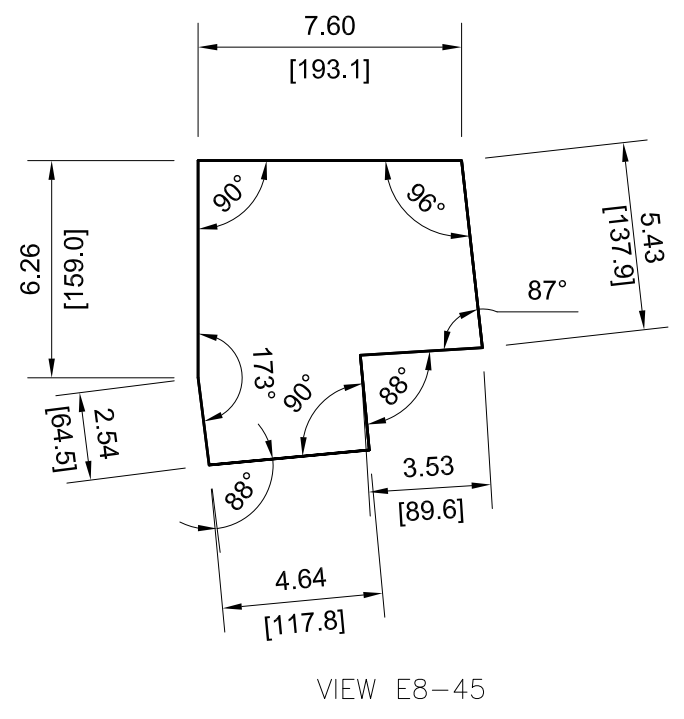
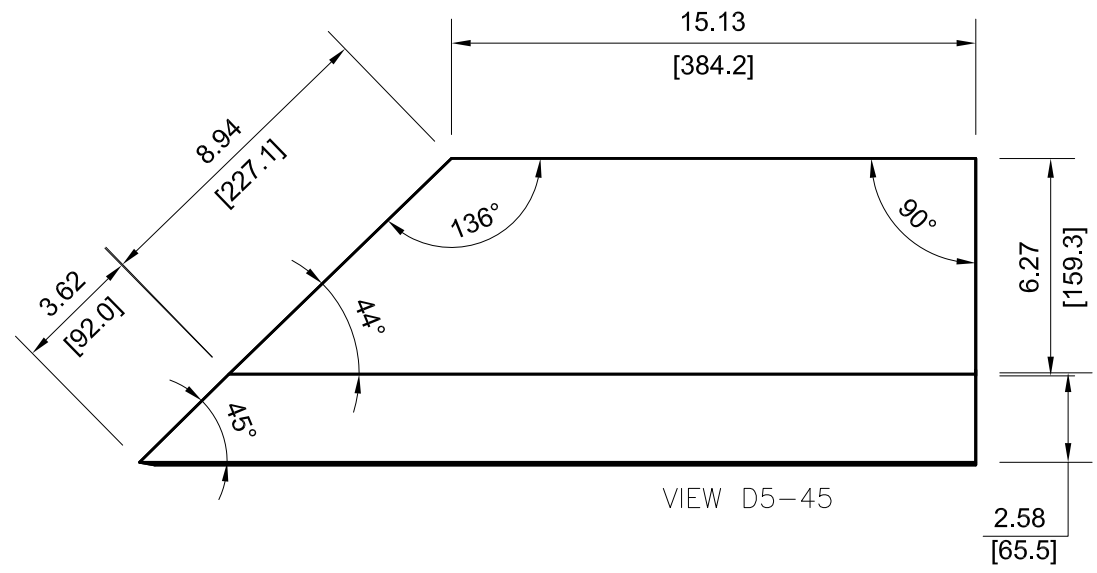

NOTE: ALL VIEWS TAKEN AS TRUE VIEWS PARALLEL TO SURFACE OF PART

	DRAWING NUMBER				
	AES-D0001				
SIZE	SCALE	SHEET	OF	REVISION	
A3	NONE	45	124	E	

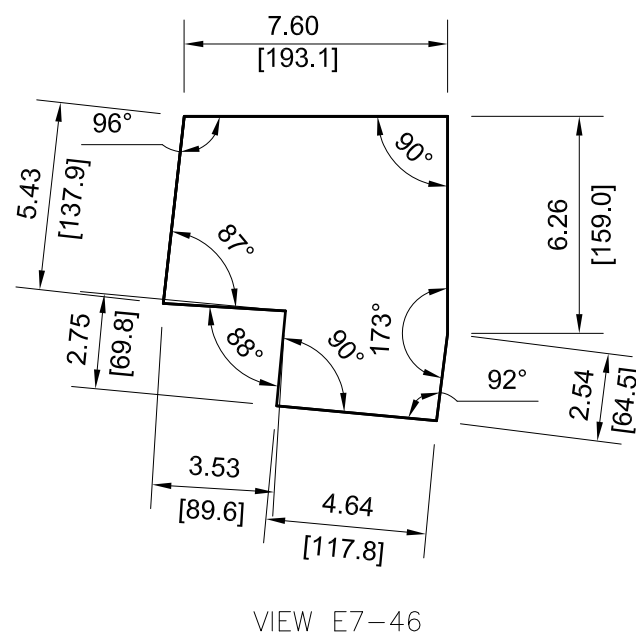
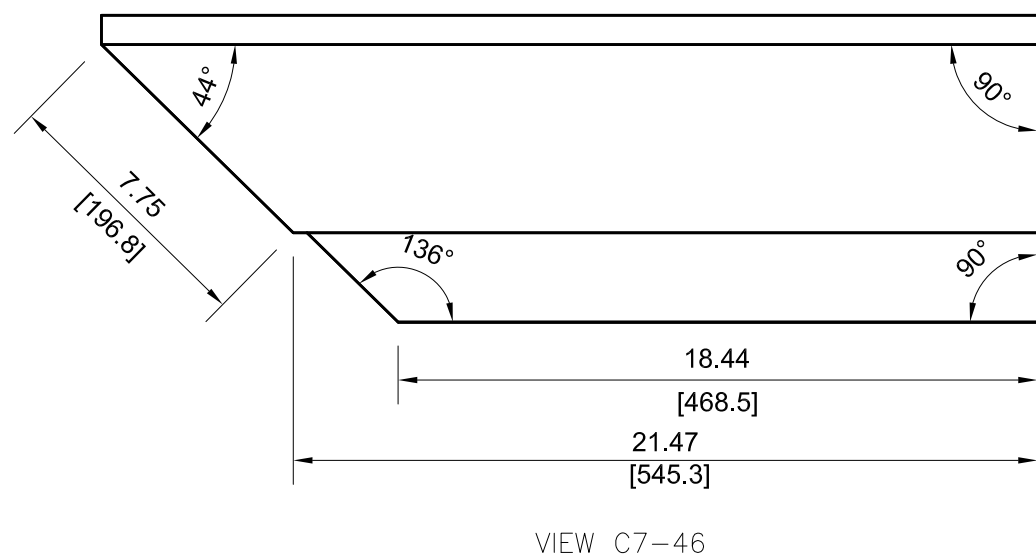
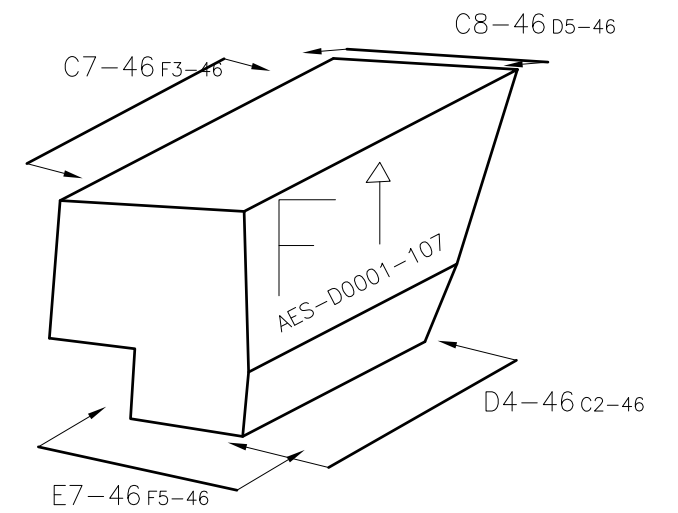
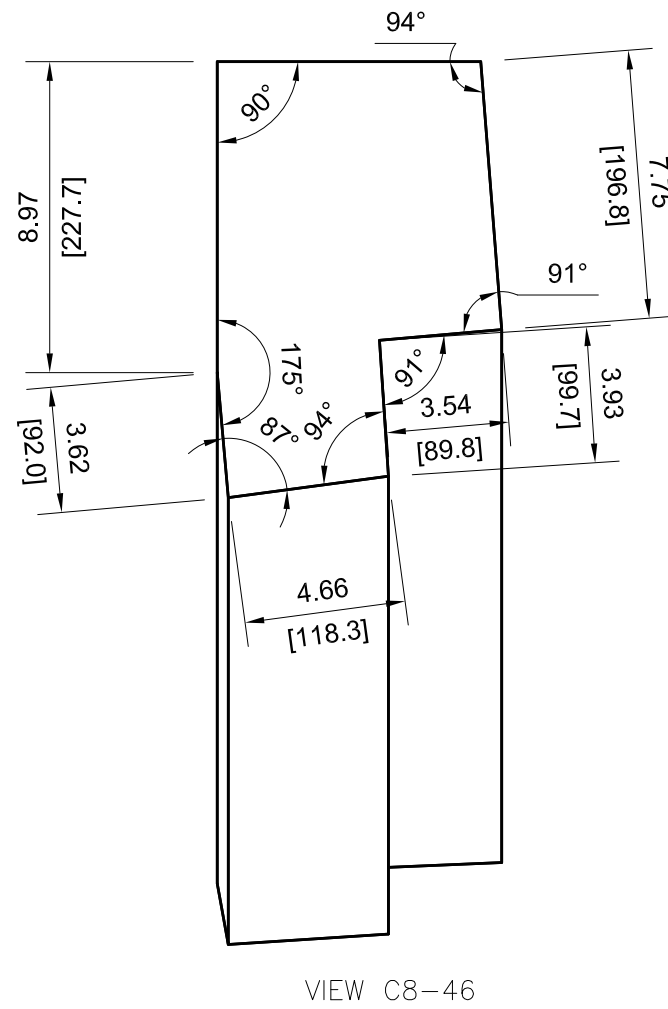
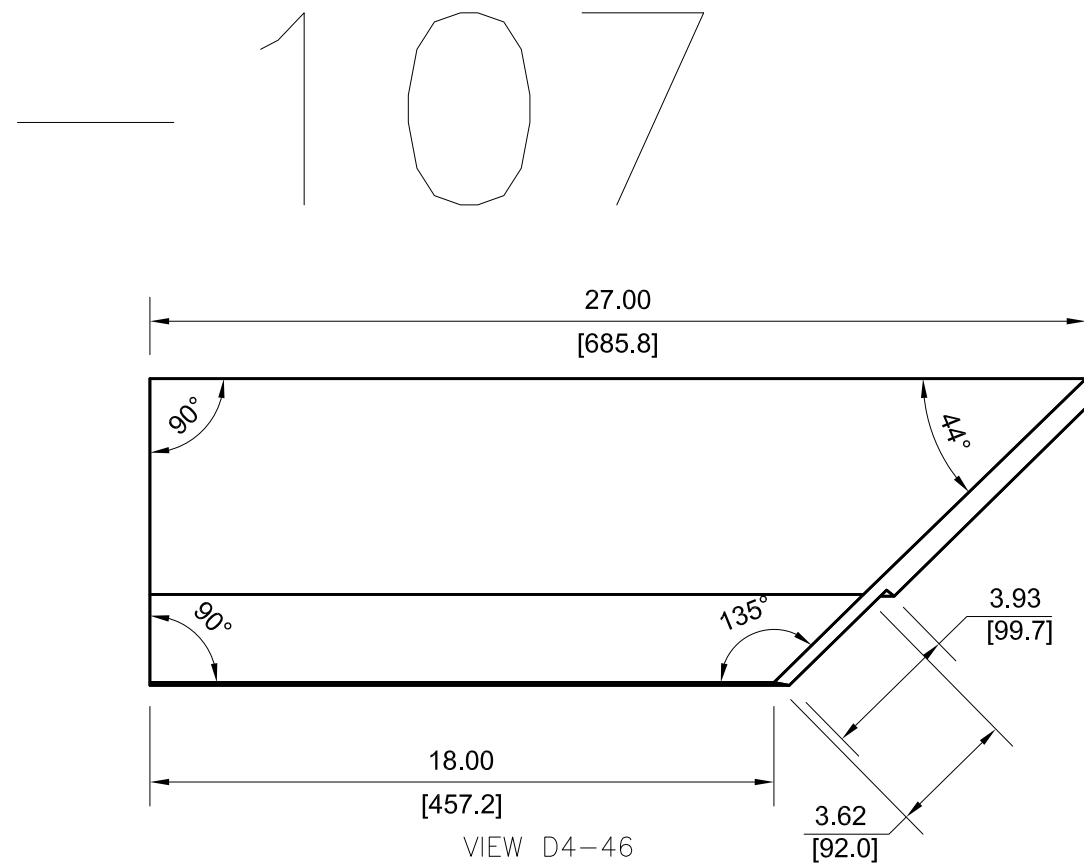

NOTE: ALL VIEWS TAKEN AS TRUE VIEWS PARALLEL TO SURFACE OF PART

	DRAWING NUMBER			
	AES-D0001			
SIZE	SCALE	SHEET	OF	REVISION
A3	NONE	46	124	E

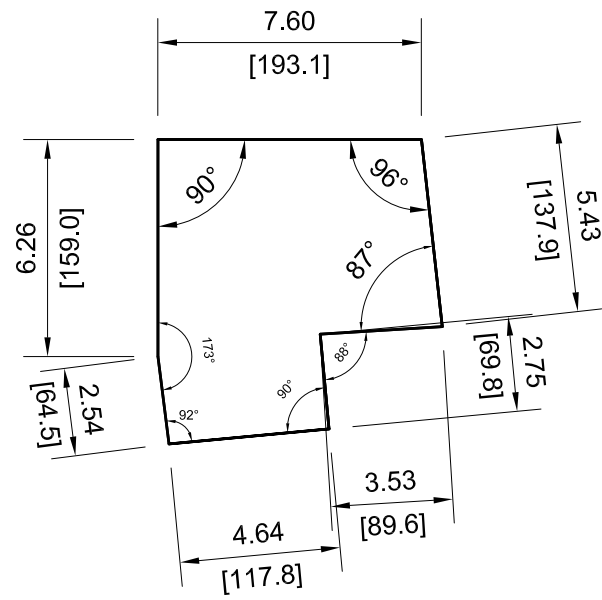

VIEW D8-47

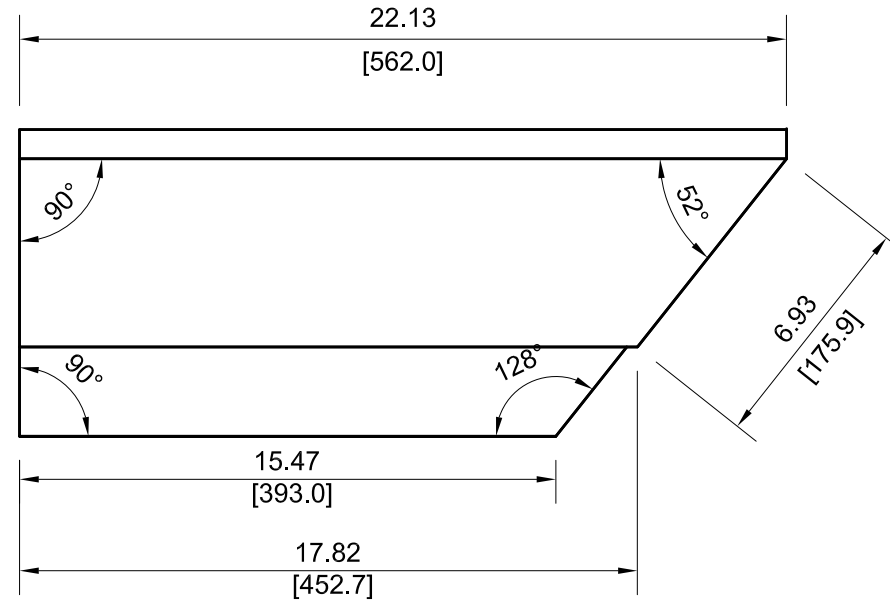

VIEW B8-47

109

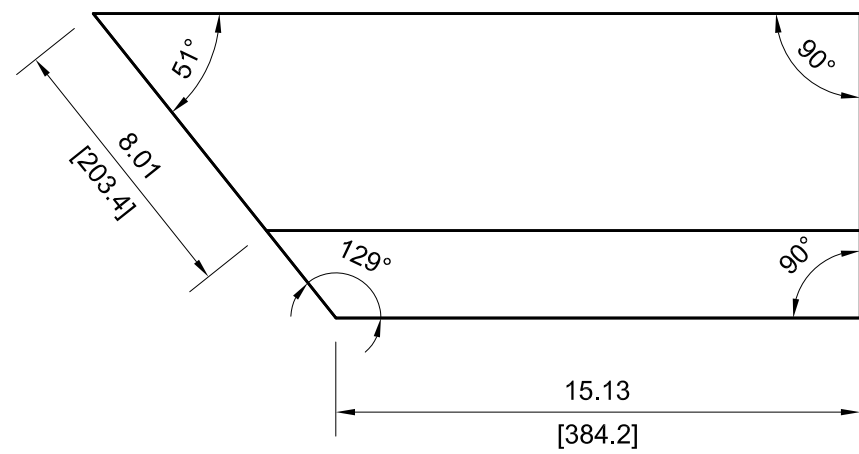
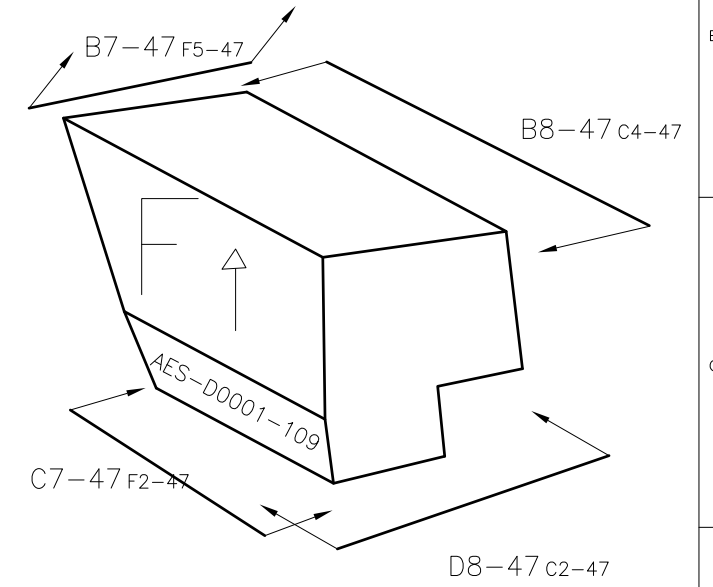

VIEW C7-47

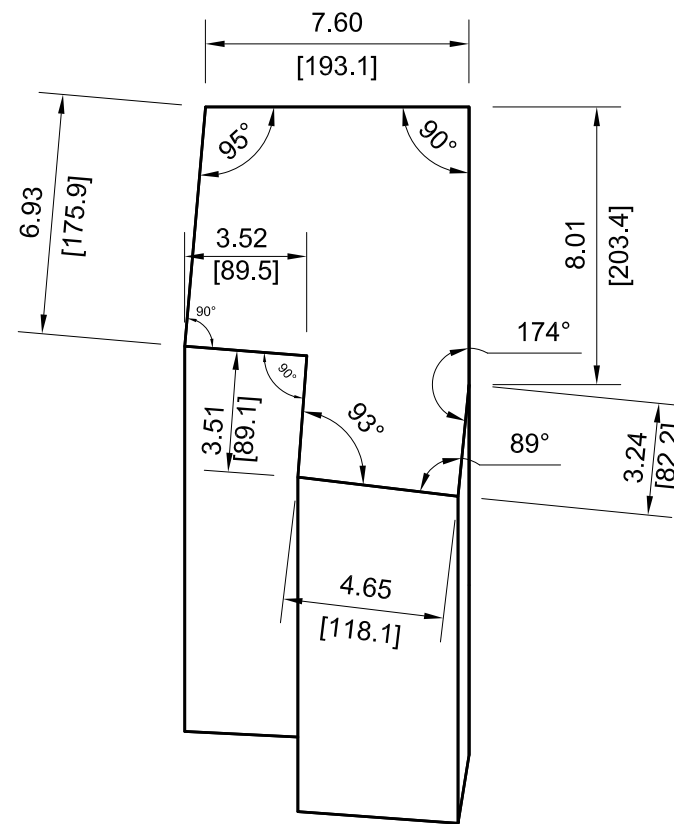

VIEW B7-47

NOTE: ALL VIEWS TAKEN AS TRUE VIEWS PARALLEL TO SURFACE OF PART



DRAWING NUMBER					AES-D0001	
SIZE	SCALE	SHEET	OF	REVISION		
A3	NONE	47	124	E		

1 1 1

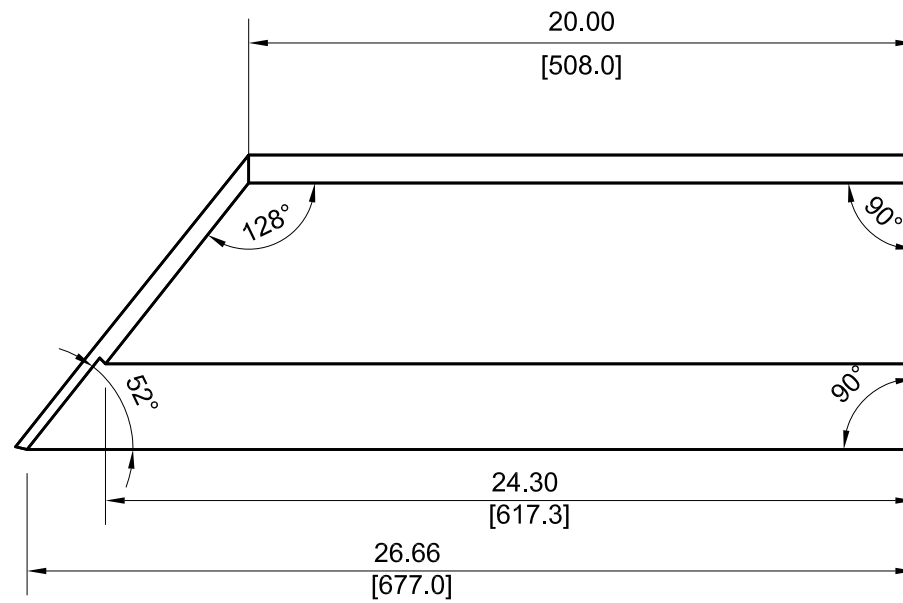

VIEW A7-48

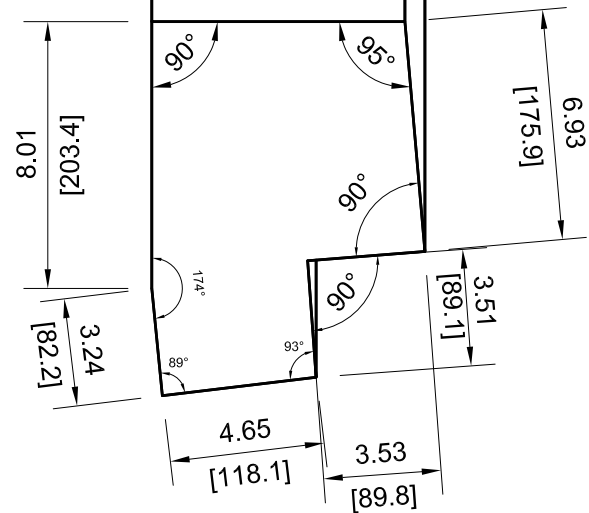

VIEW C8-48

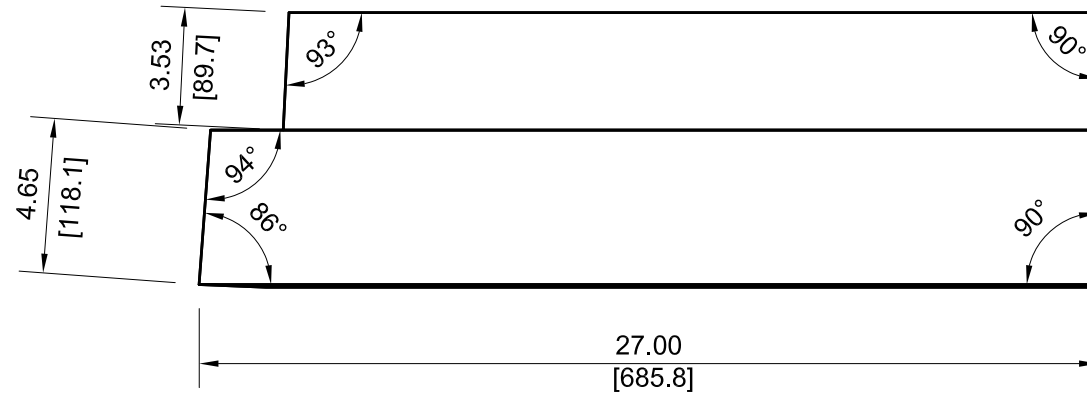

VIEW C7-48

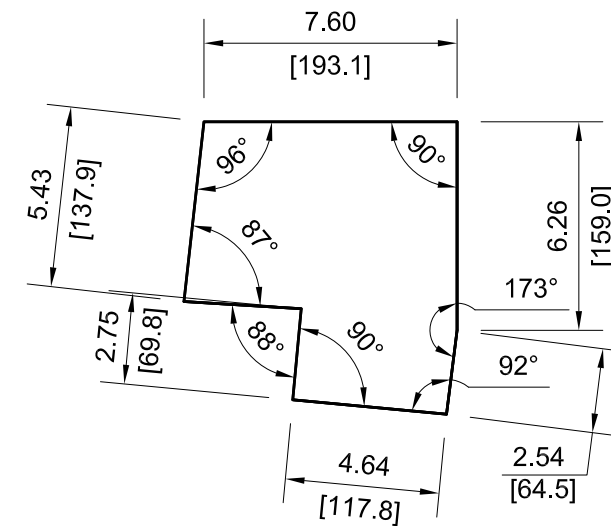
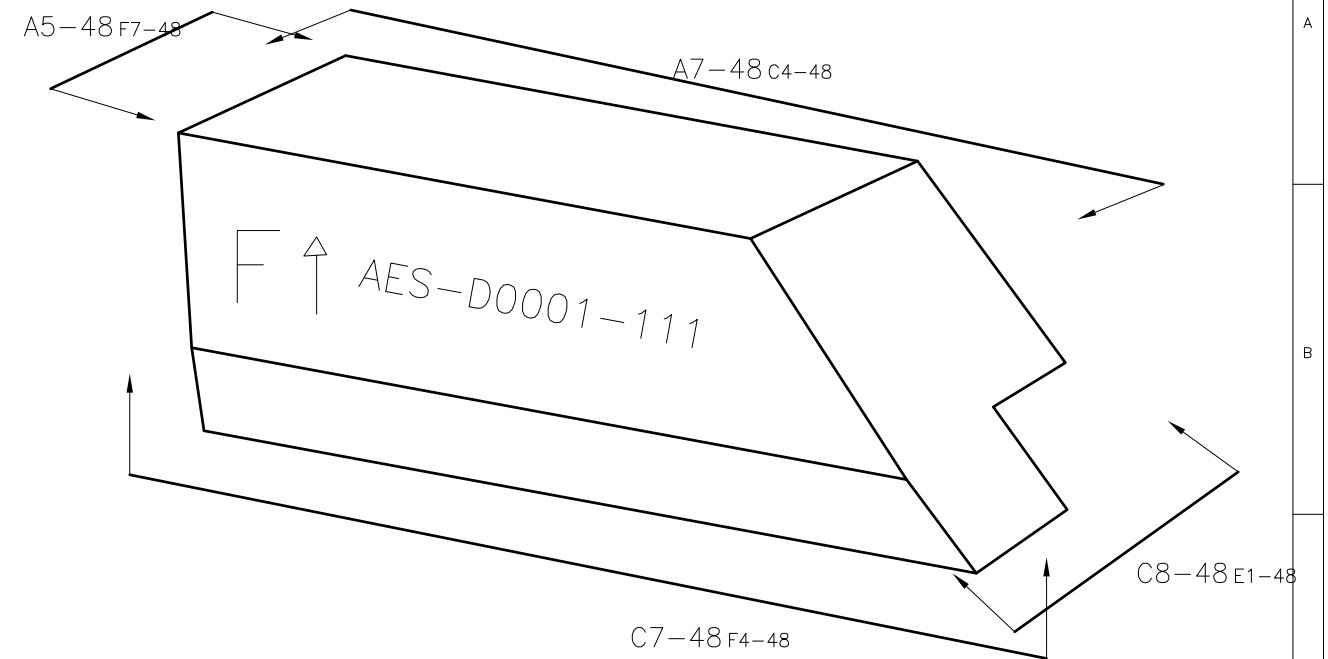

VIEW A5-48

NOTE: ALL VIEWS TAKEN AS TRUE VIEWS PARALLEL TO SURFACE OF PART

		DRAWING NUMBER			
		AES-D0001			
SIZE	SCALE	SHEET	OF	REVISION	
A3	NONE	48	124	E	

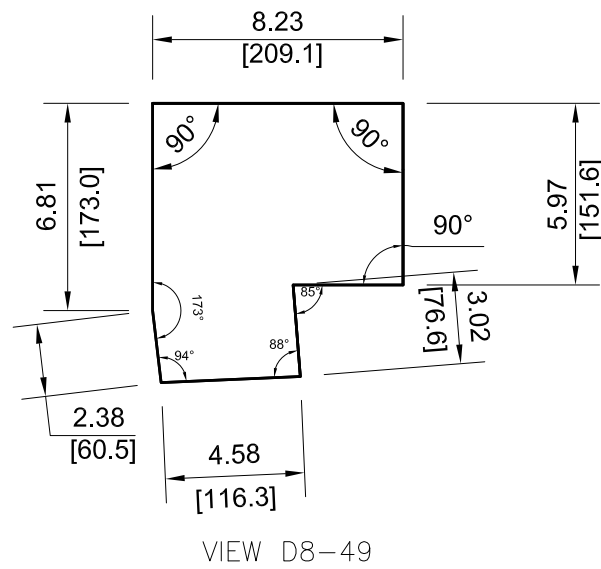
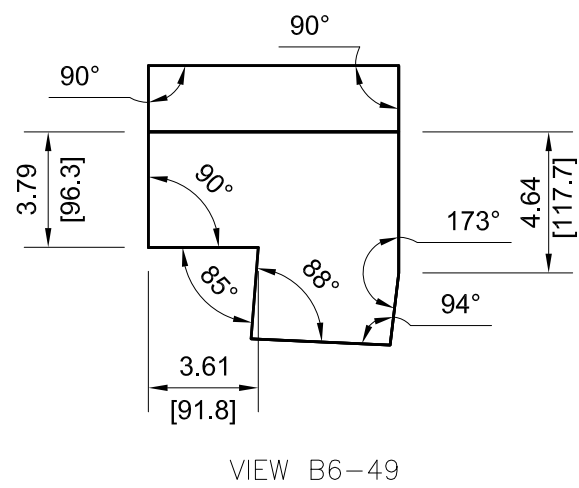
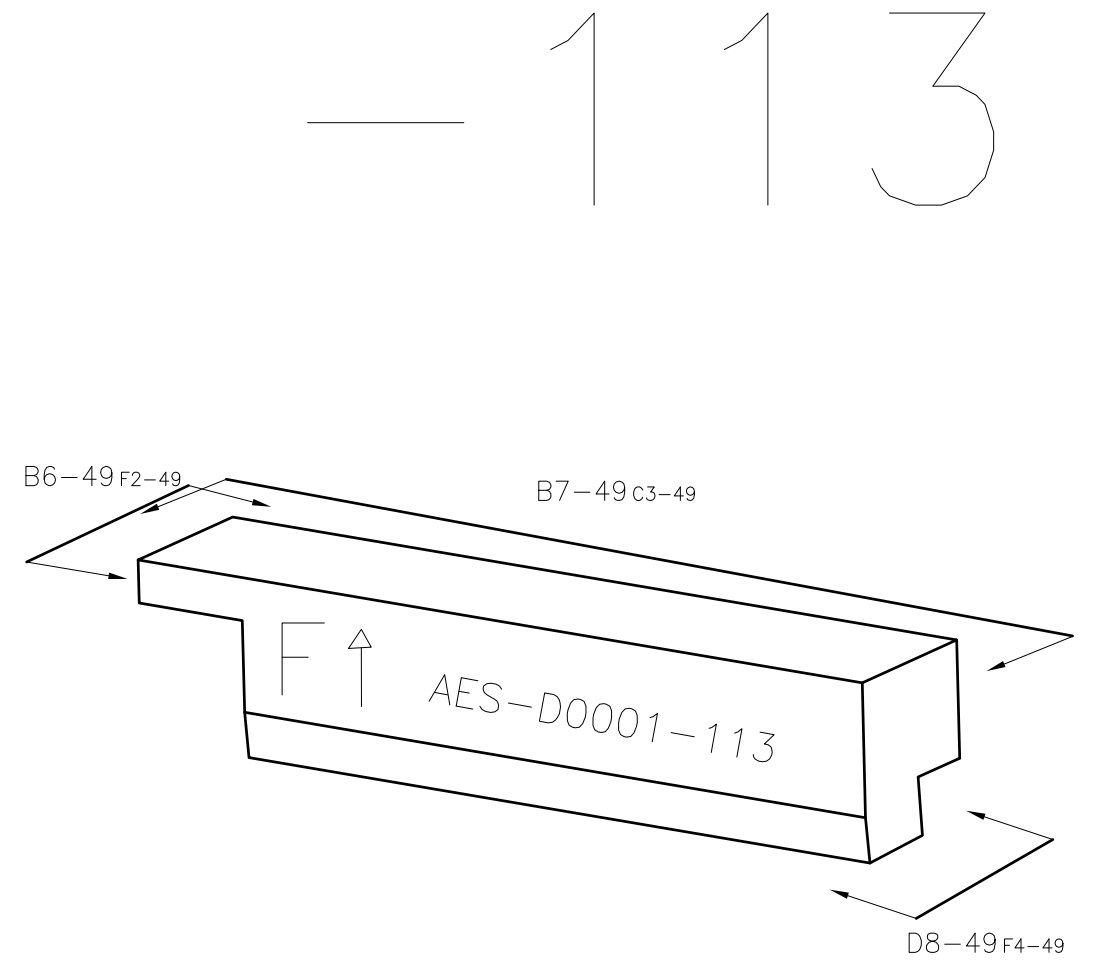
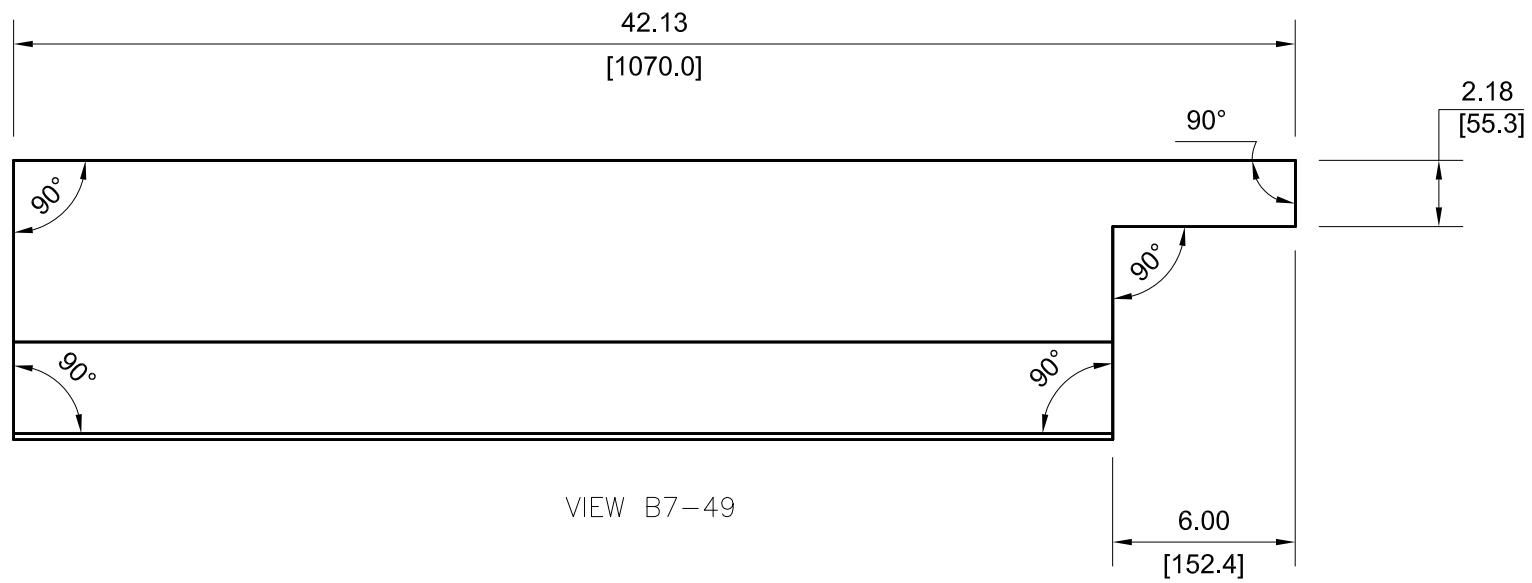

NOTE: ALL VIEWS TAKEN AS TRUE VIEWS PARALLEL TO SURFACE OF PART

	DRAWING NUMBER				
	AES-D0001				
SIZE	SCALE	SHEET	OF	REVISION	
A3	NONE	49	124	E	

115

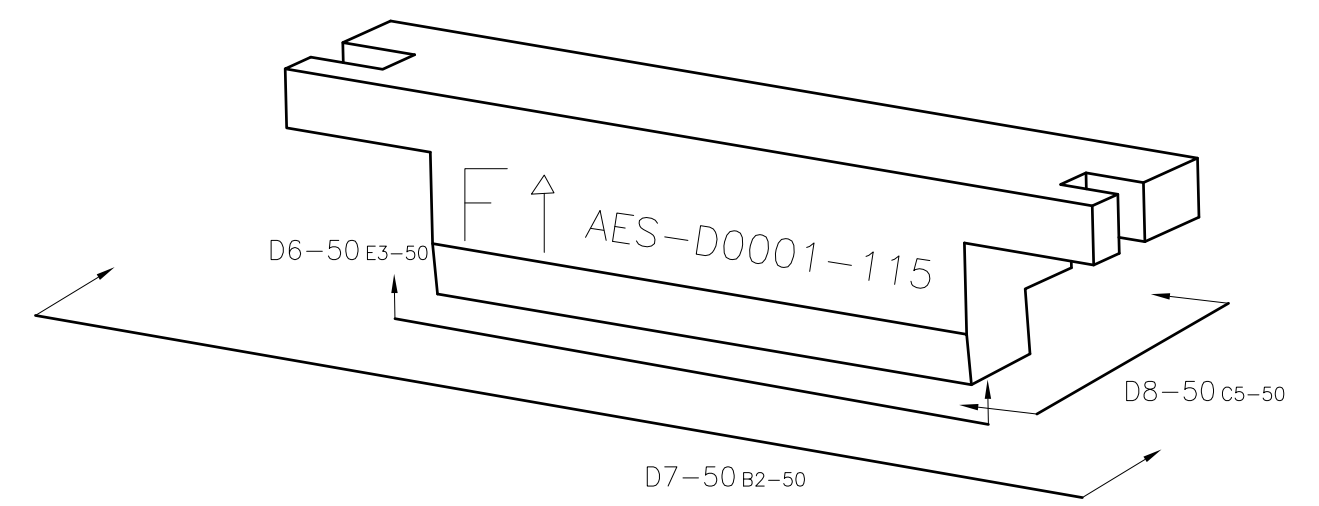
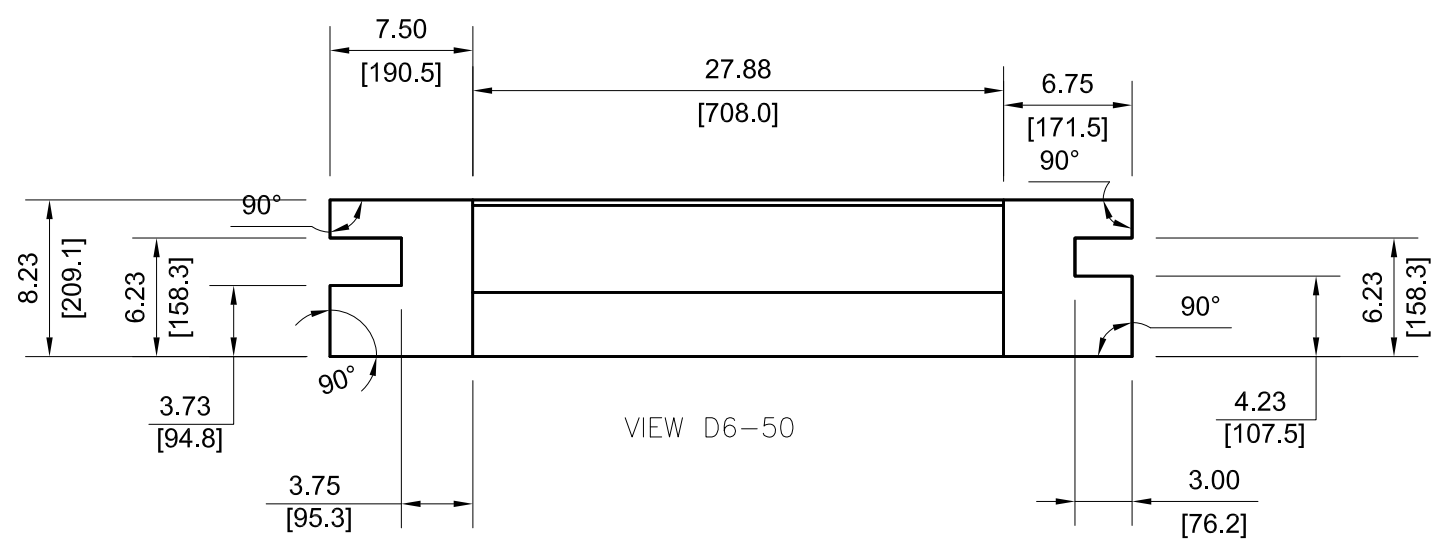
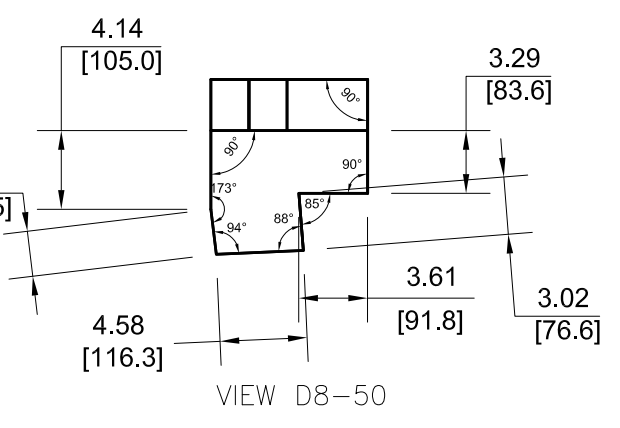
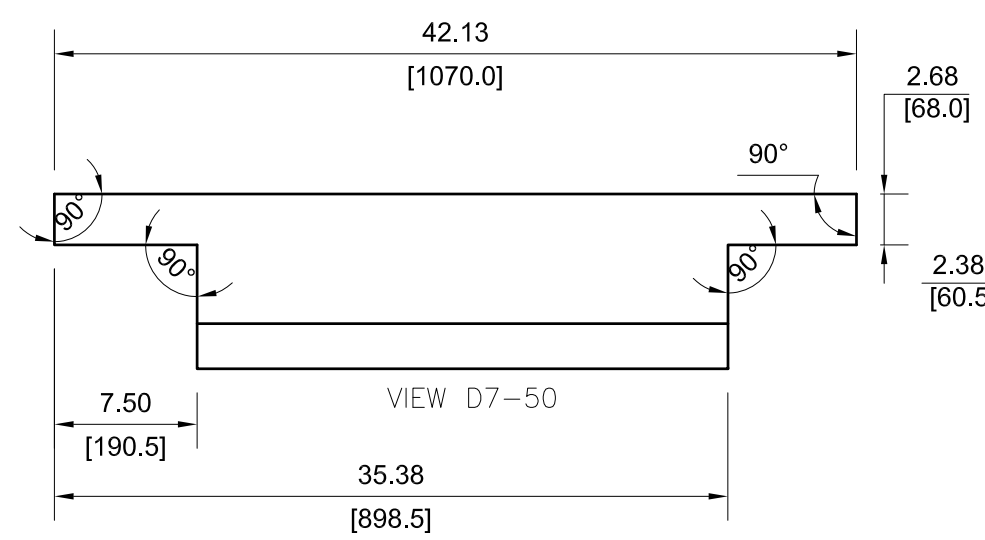

NOTE: ALL VIEWS TAKEN AS TRUE VIEWS PARALLEL TO SURFACE OF PART

	DRAWING NUMBER				
	AES-D0001				
SIZE	SCALE	SHEET	OF	REVISION	
A3	NONE	50	124	E	

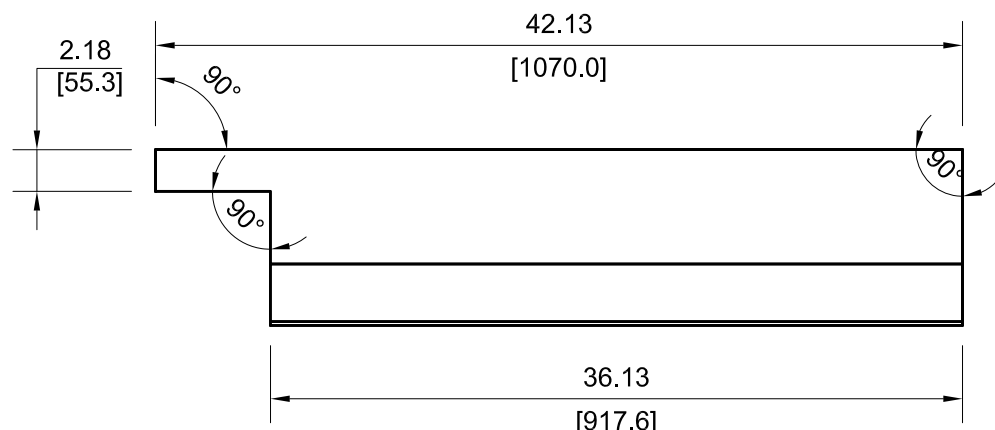

VIEW D7-51

117

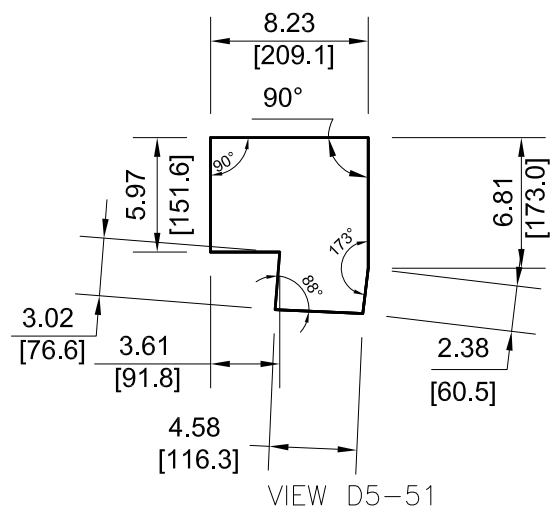

VIEW D5-51

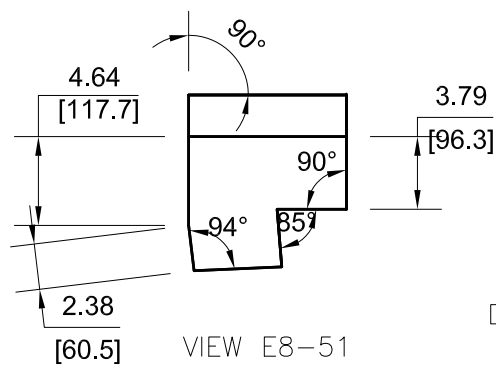

VIEW E8-51

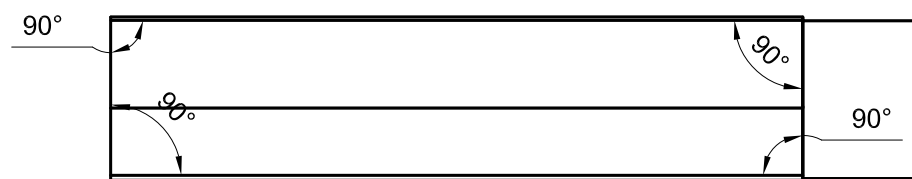
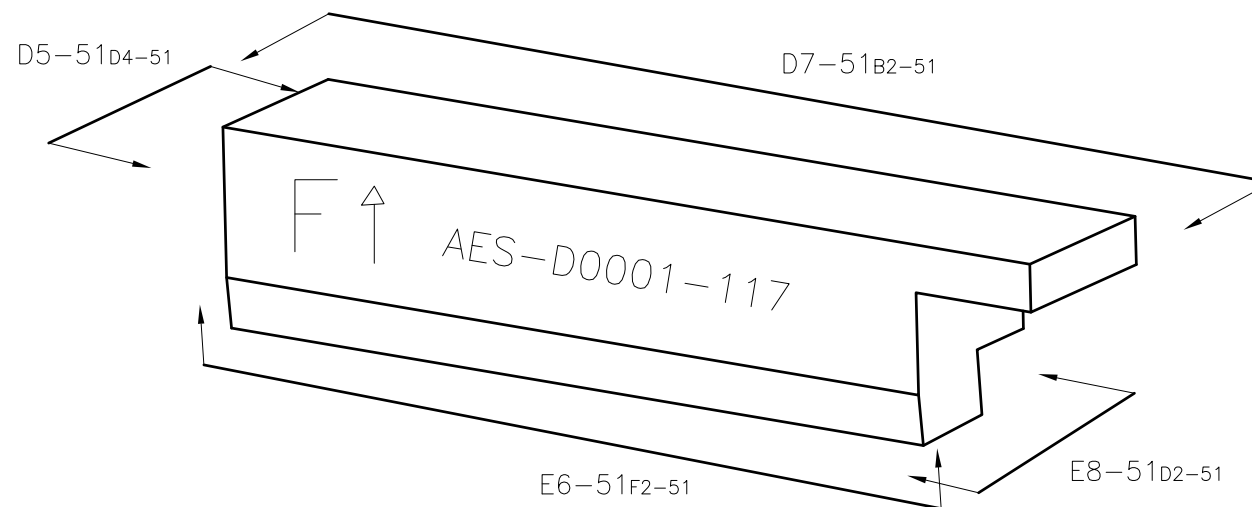

VIEW E6-51

NOTE: ALL VIEWS TAKEN AS TRUE VIEWS PARALLEL TO SURFACE OF PART



DRAWING NUMBER					AES-D0001	
SIZE	SCALE	SHEET	OF	REVISION		
A3	NONE	51	124	E		

119

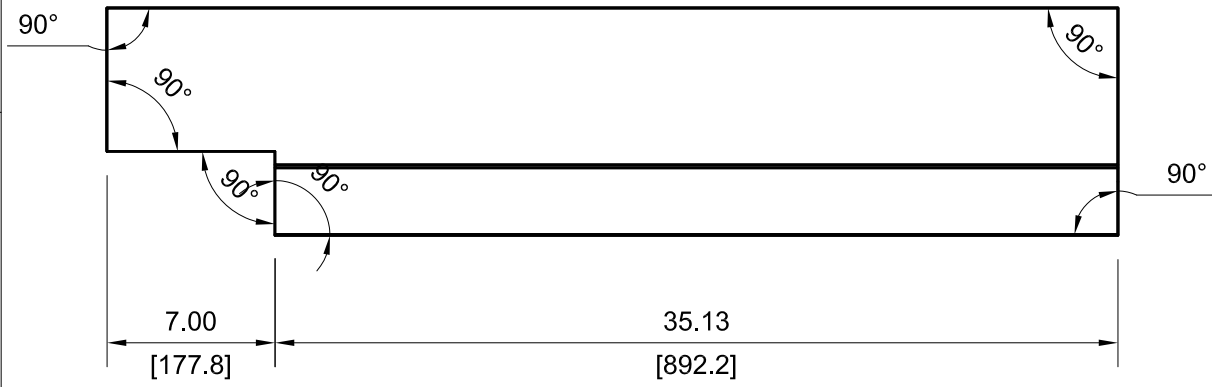
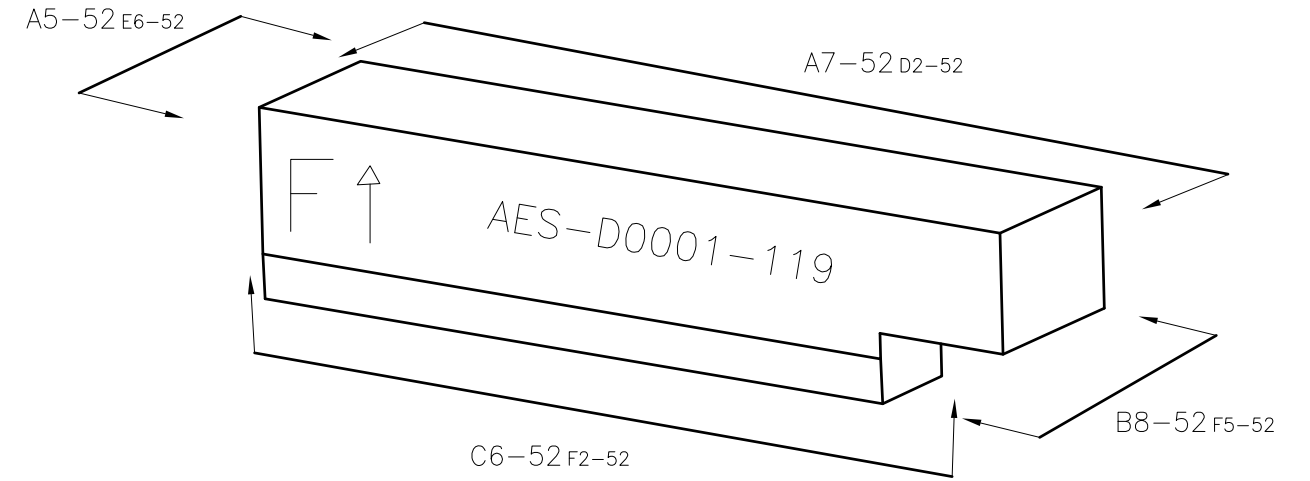

VIEW A7-52

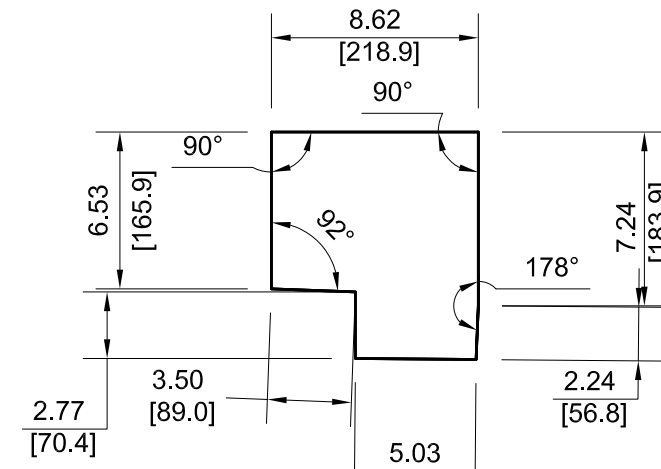

VIEW A5-52

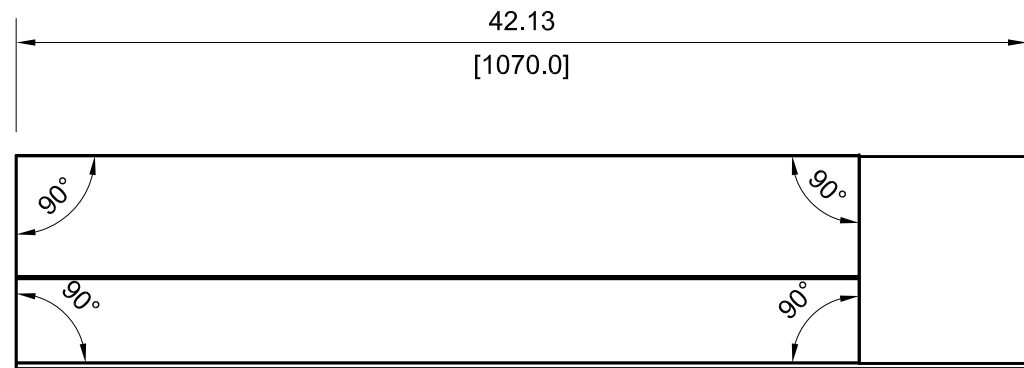

VIEW C6-52

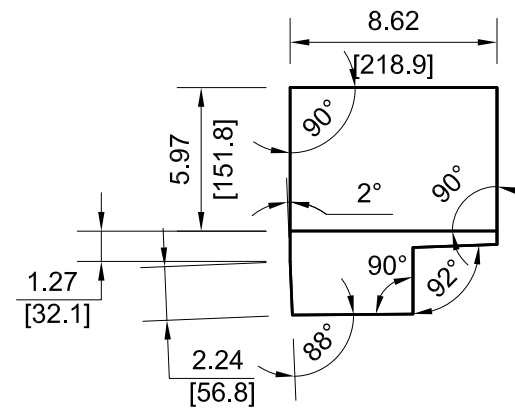

VIEW B8-52

NOTE: ALL VIEWS TAKEN AS TRUE VIEWS PARALLEL TO SURFACE OF PART



DRAWING NUMBER					AES-D0001	
SIZE	SCALE	SHEET	OF	REVISION		
A3	NONE	52	124	E		

# 121

A5-53 D3-53

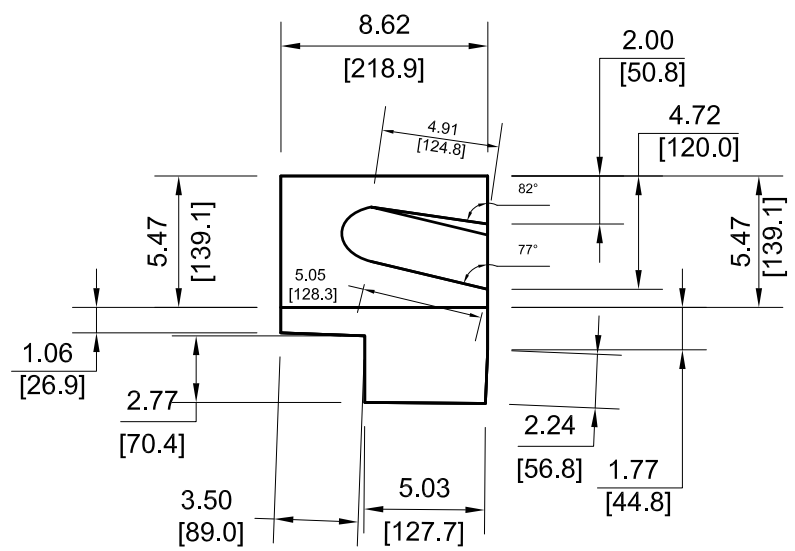
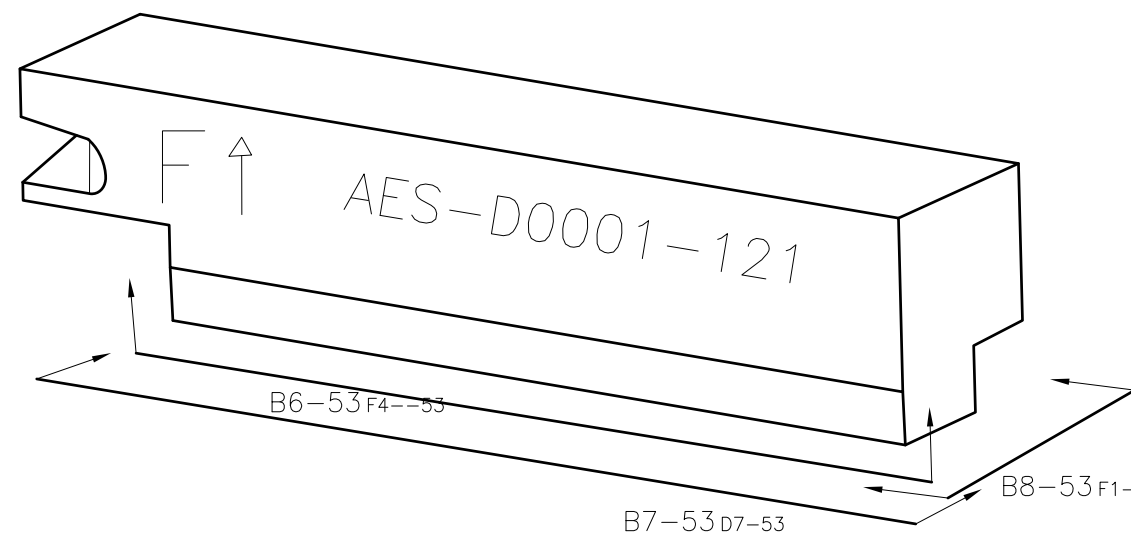

VIEW A5-53

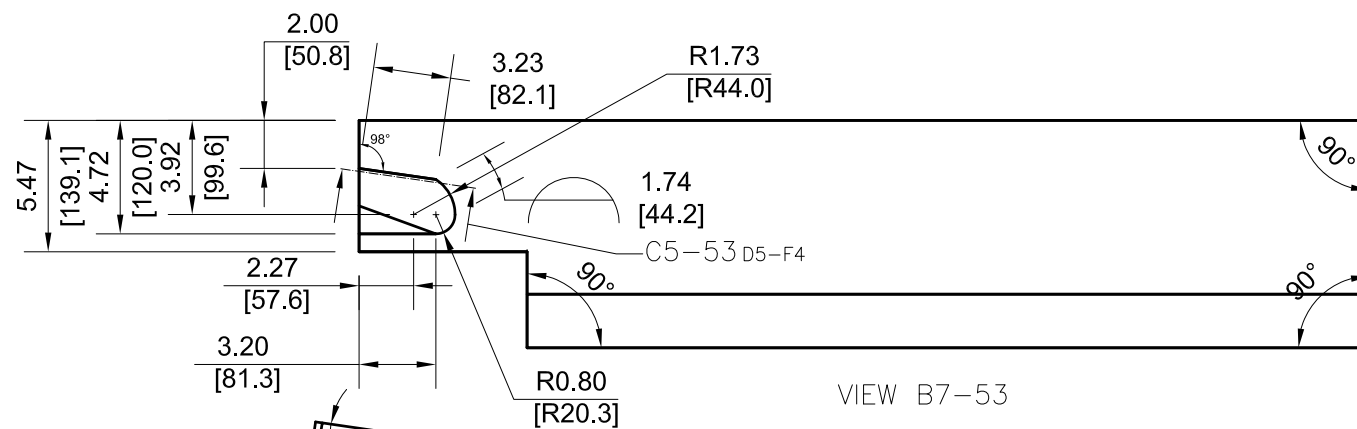

VIEW B7-53

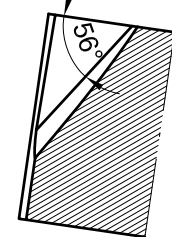

SECTION VIEW C5-53

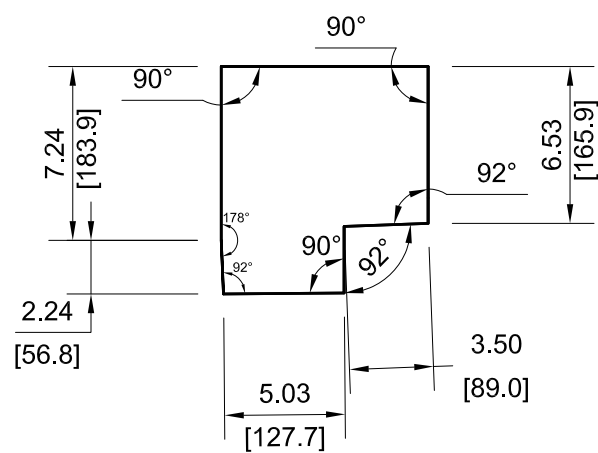

VIEW B8-53

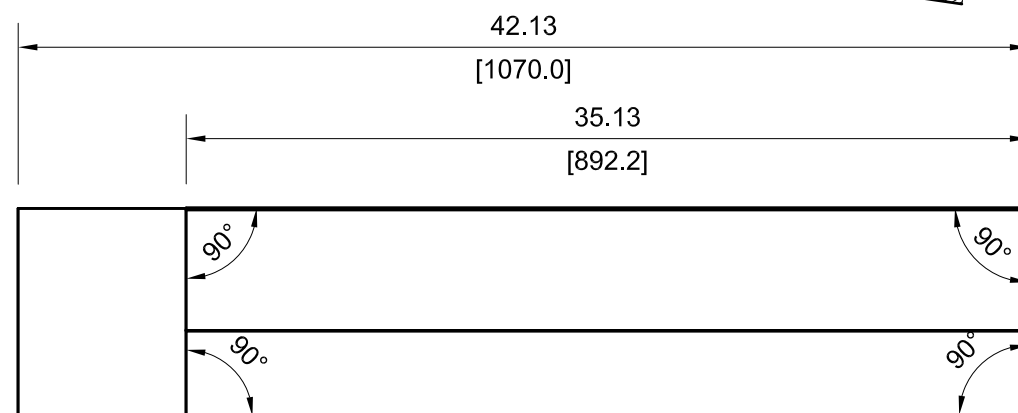

VIEW B6-53

NOTE: ALL VIEWS TAKEN AS TRUE VIEWS PARALLEL TO SURFACE OF PART



DRAWING NUMBER					AES-D0001				
SIZE	SCALE	SHEET	OF	REVISION					
A3	NONE	53	124	E					

123

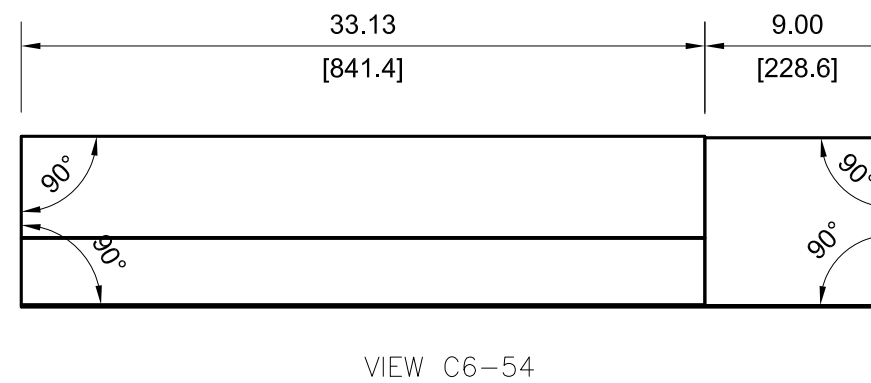
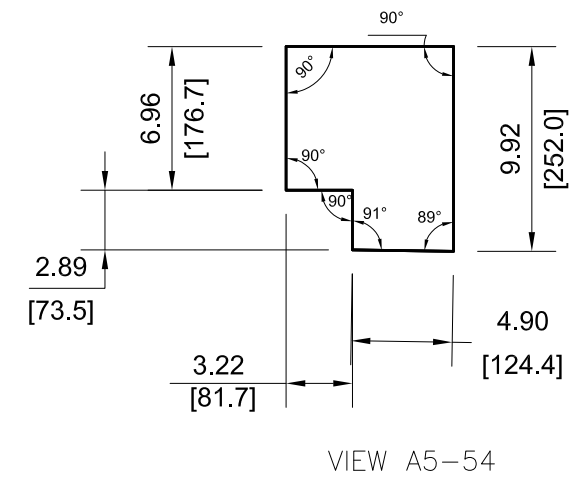
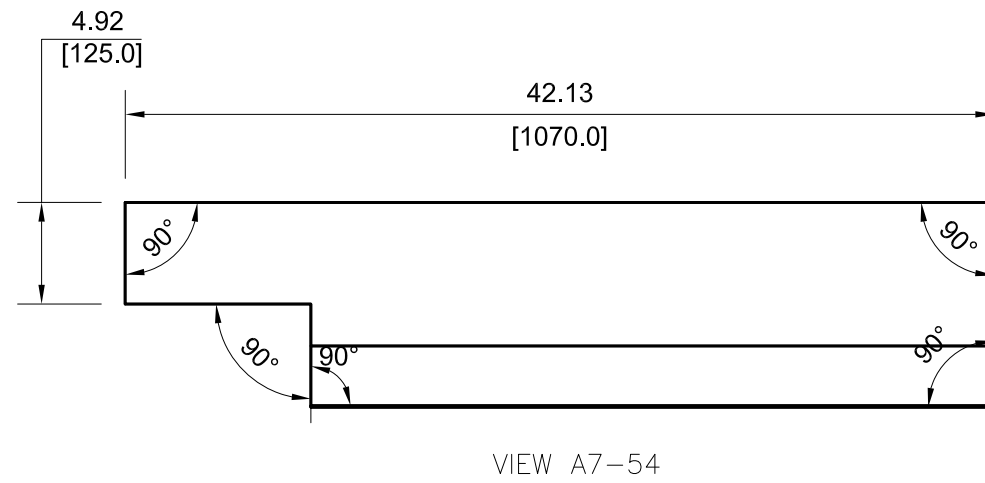
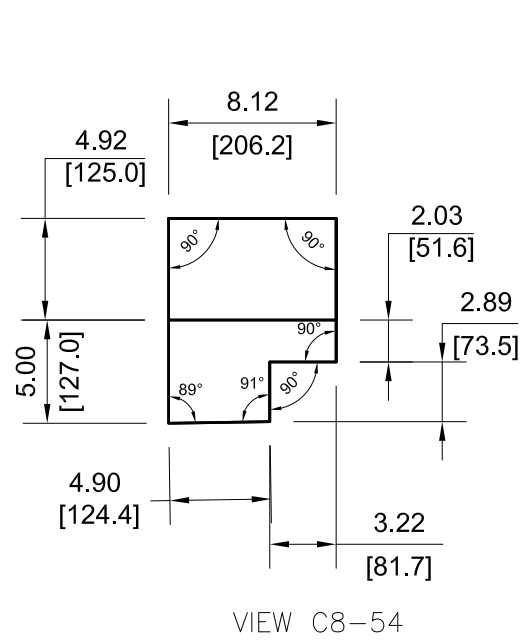
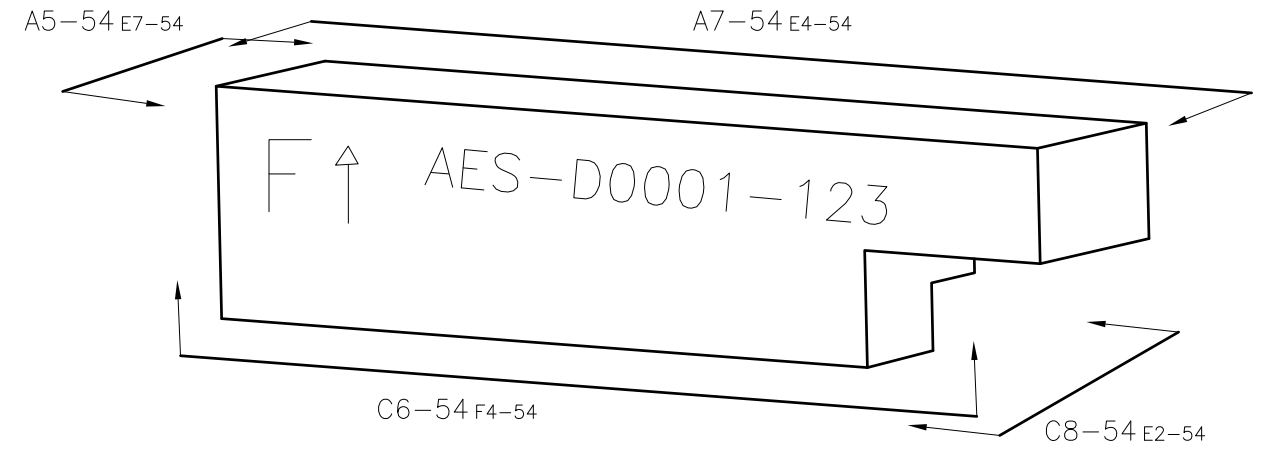

NOTE: ALL VIEWS TAKEN AS TRUE VIEWS PARALLEL TO SURFACE OF PART

		DRAWING NUMBER			
		AES-D0001			
SIZE	SCALE	SHEET	OF	REVISION	
A3	NONE	54	124	E	

125

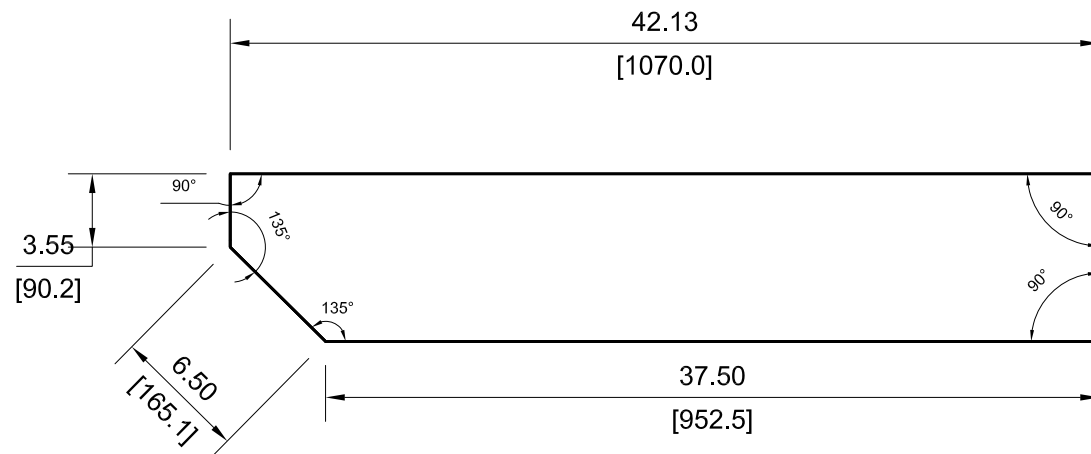

VIEW A7-55

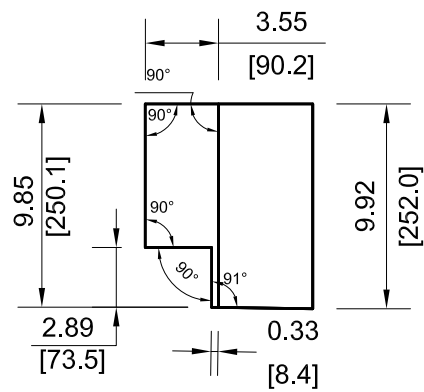

VIEW B5-55

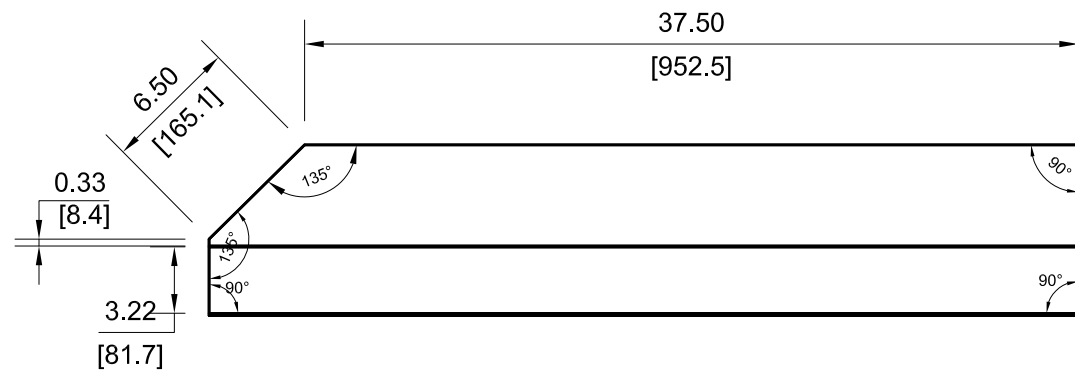

VIEW C7-55

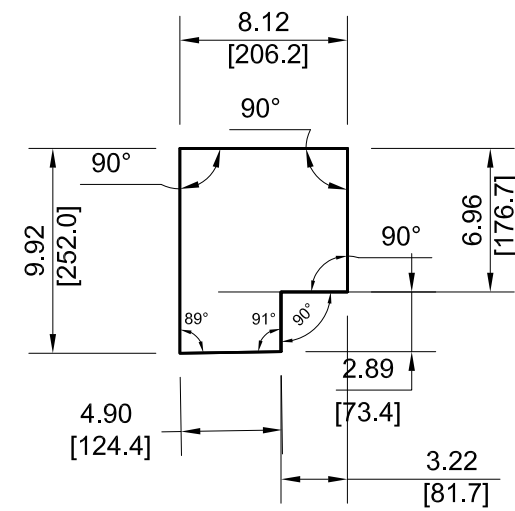
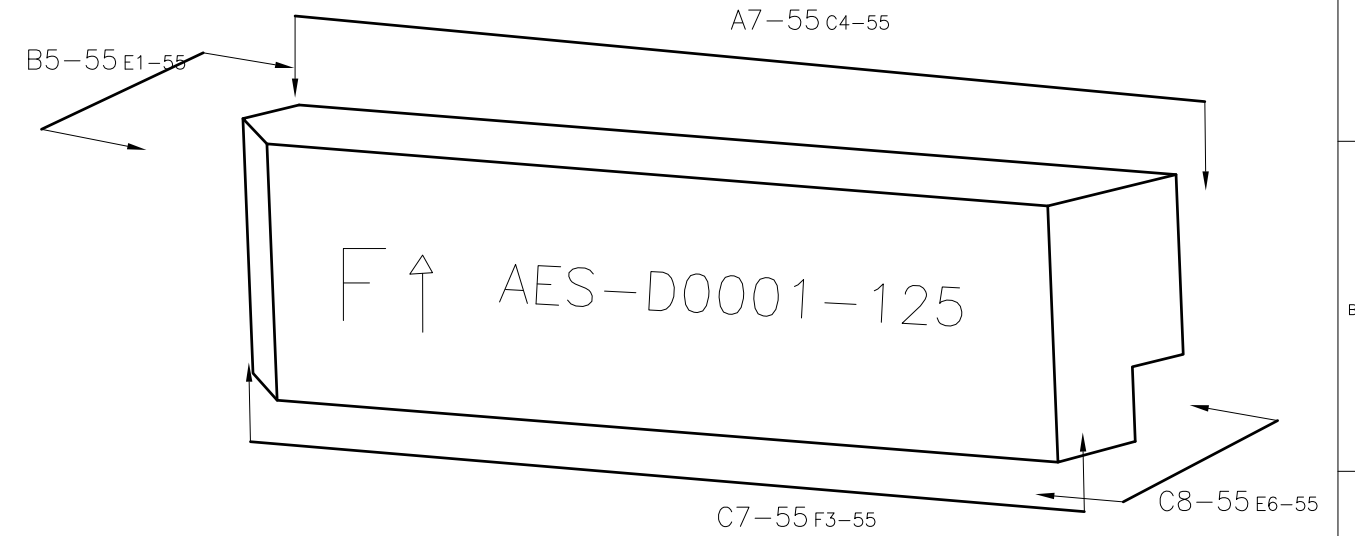

VIEW C8-55

NOTE: ALL VIEWS TAKEN AS TRUE VIEWS PARALLEL TO SURFACE OF PART



DRAWING NUMBER					AES-D0001	
SIZE	SCALE	SHEET	OF	REVISION		
A3	NONE	55	124	E		

# 127

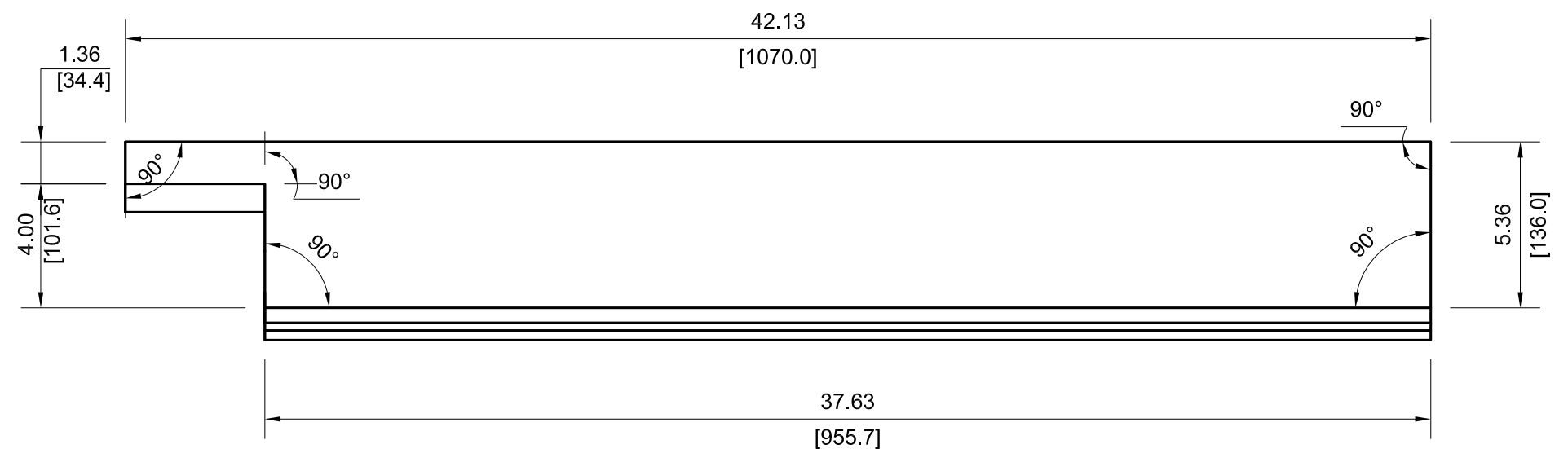
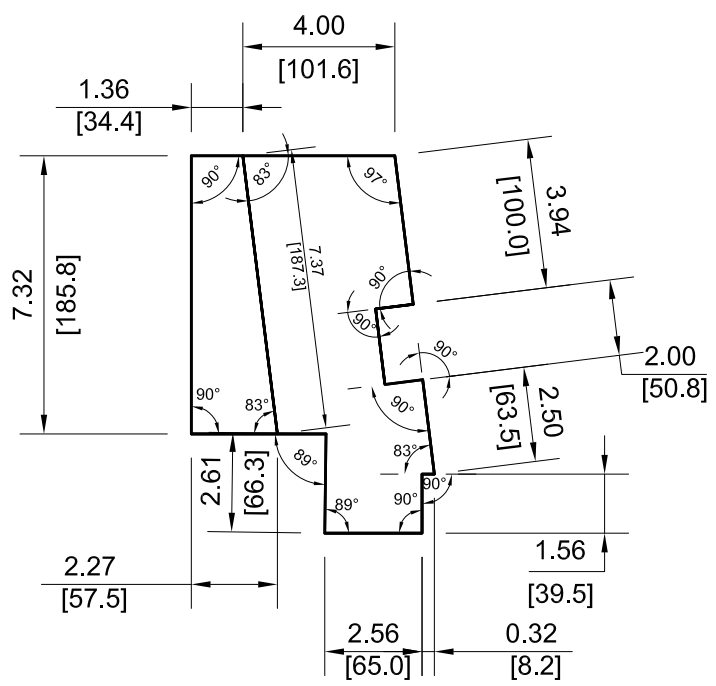
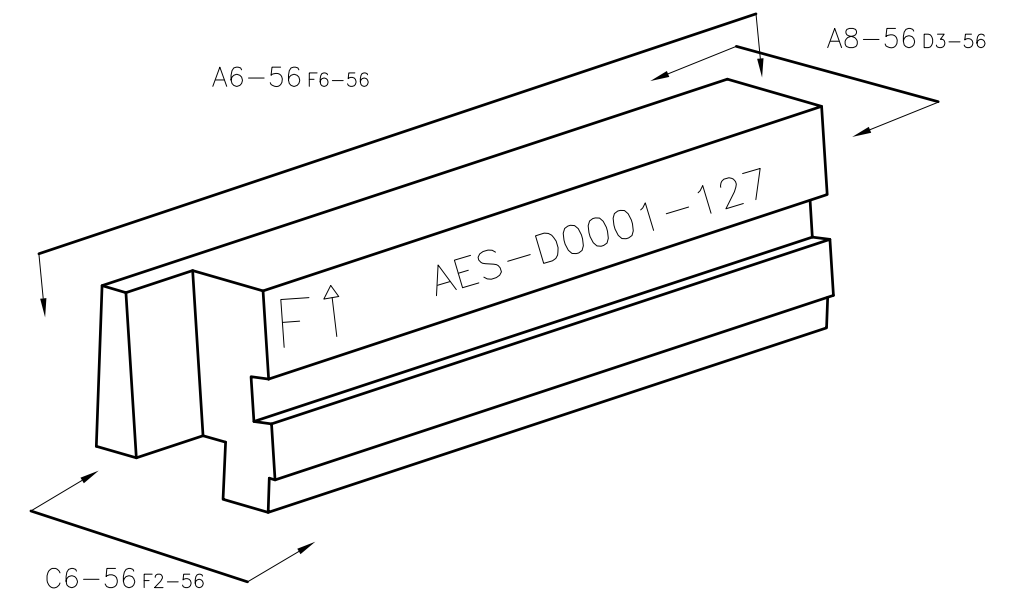
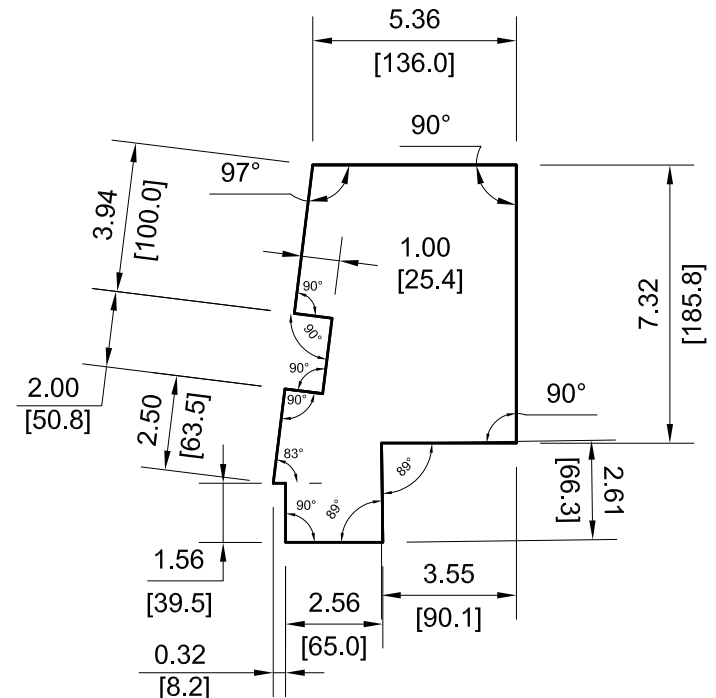

NOTE: ALL VIEWS TAKEN AS TRUE VIEWS PARALLEL TO SURFACE OF PART

		DRAWING NUMBER			
		AES-D0001			
SIZE	SCALE	SHEET	OF	REVISION	
A3	NONE	56	124	E	

129

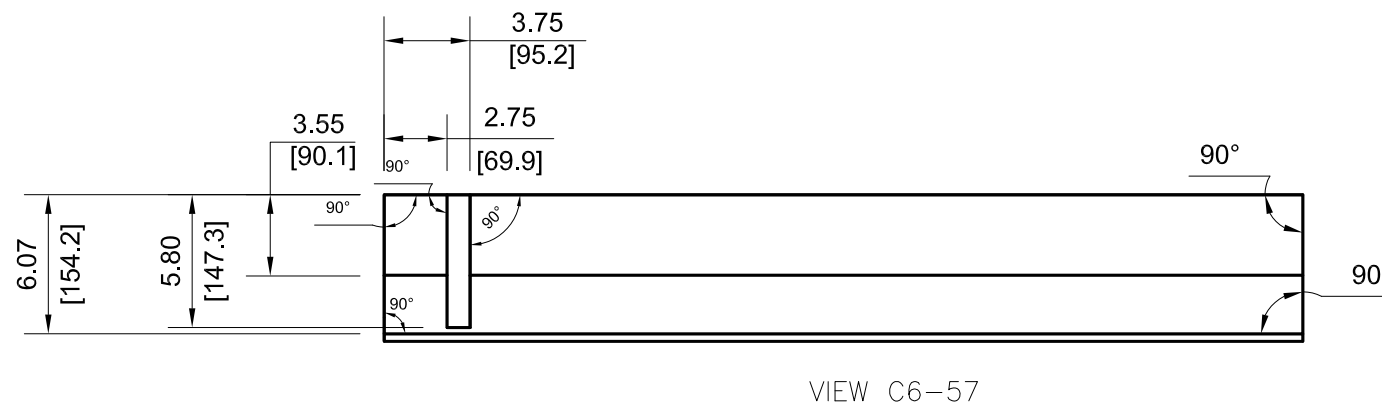
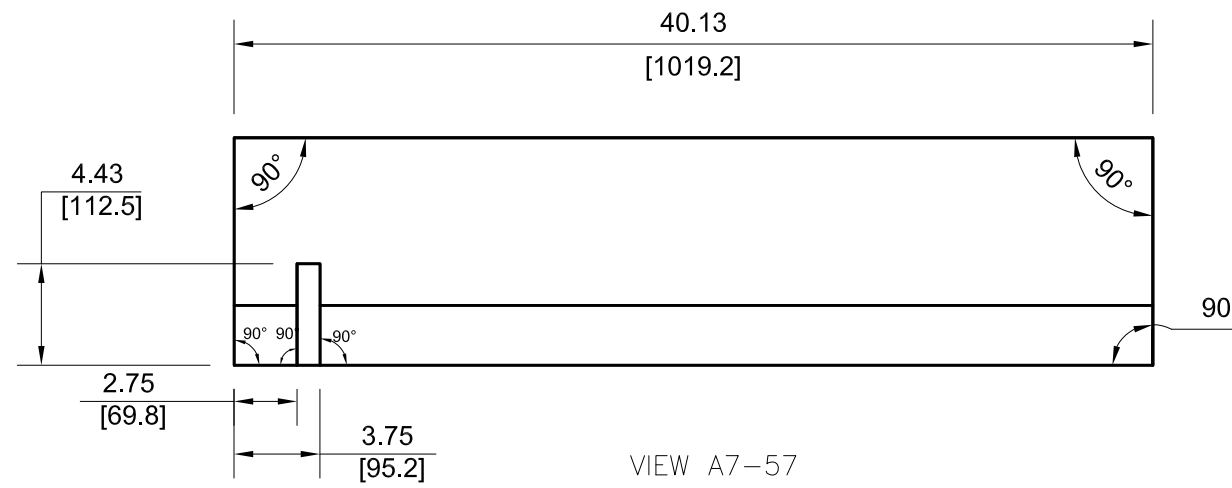
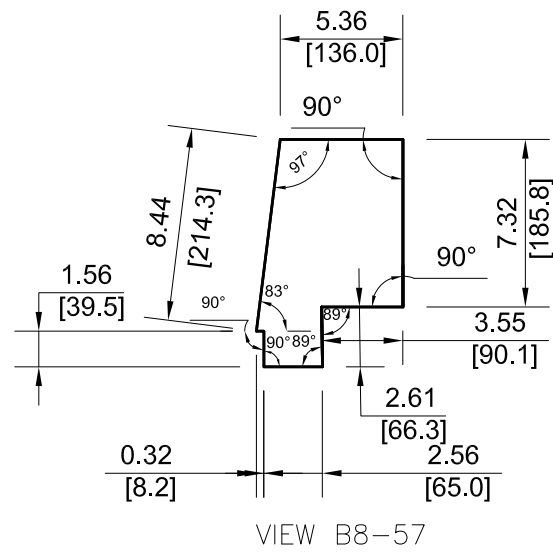
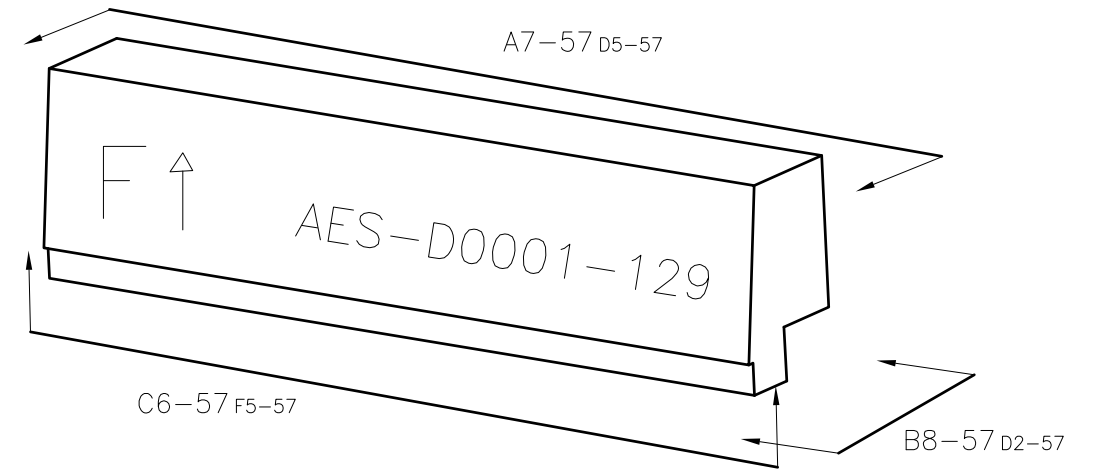

NOTE: ALL VIEWS TAKEN AS TRUE VIEWS PARALLEL TO SURFACE OF PART

		DRAWING NUMBER			
		AES-D0001			
SIZE	SCALE	SHEET	OF	REVISION	
A3	NONE	57	124	E	

131

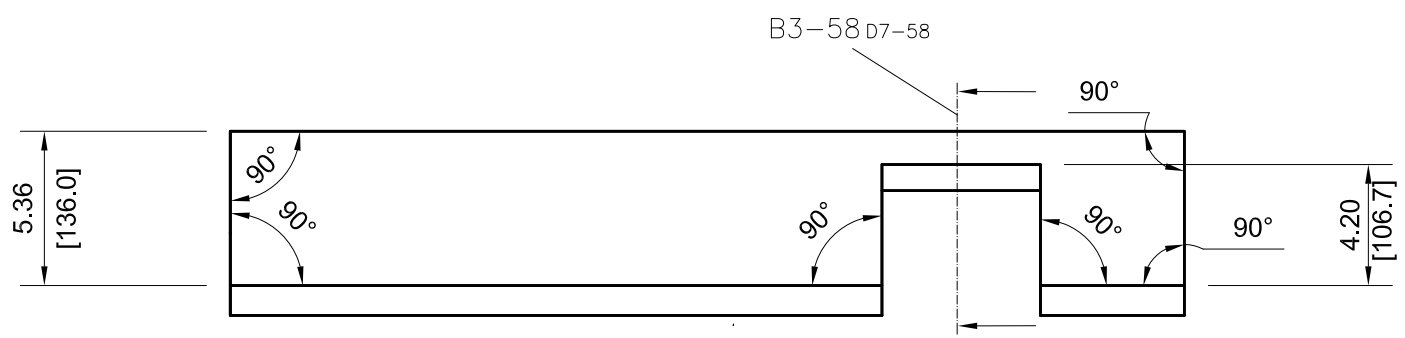
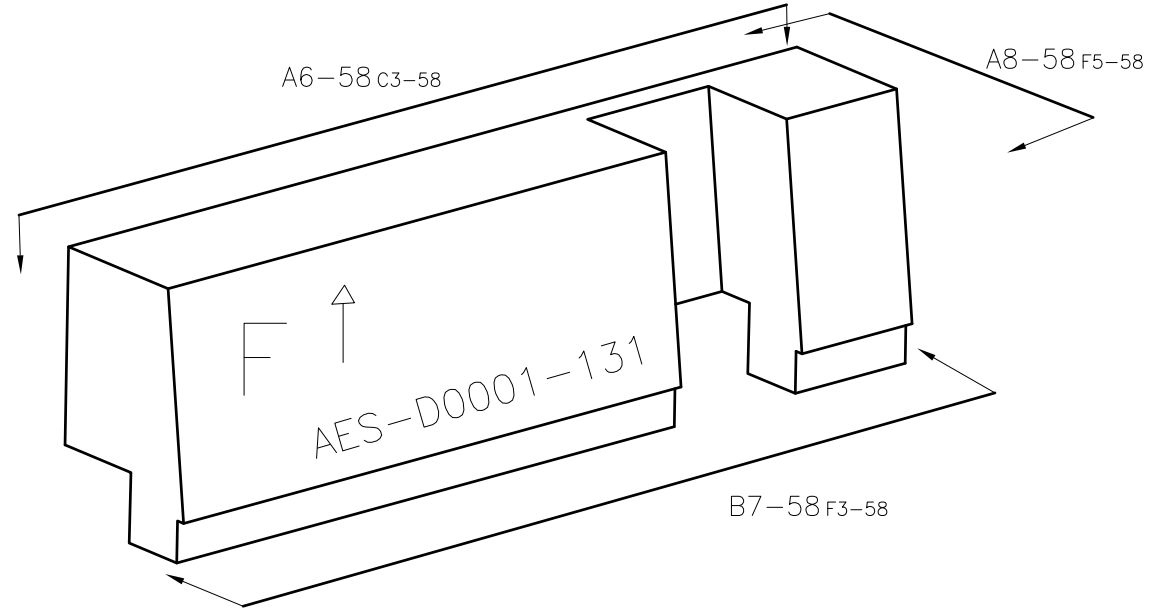

VIEW A6-58

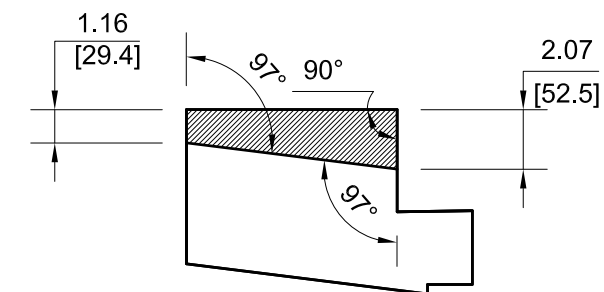

SECTION VIEW B3-58

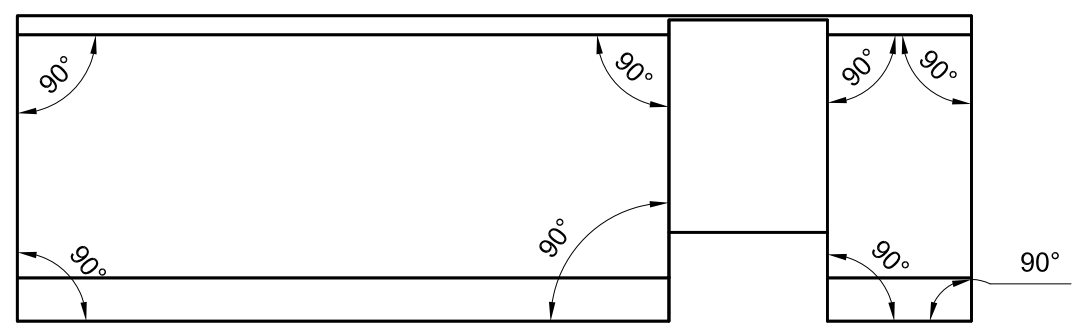
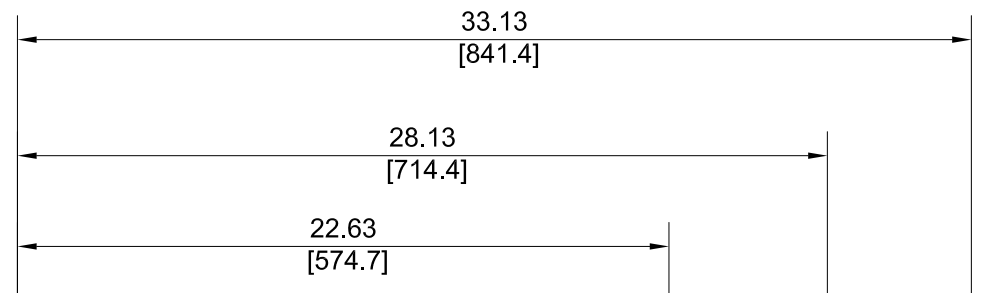

VIEW B7-58

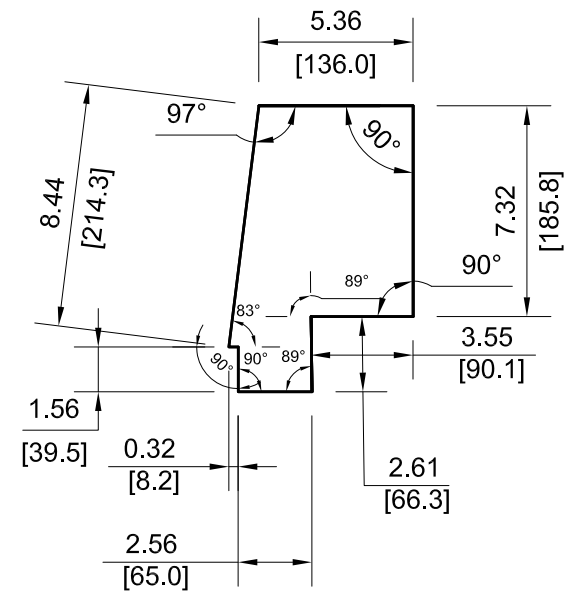

VIEW A8-58

NOTE: ALL VIEWS TAKEN AS TRUE VIEWS PARALLEL TO SURFACE OF PART



DRAWING NUMBER					AES-D0001	
SIZE	SCALE	SHEET	OF	REVISION		
A3	NONE	58	124	E		

— 133

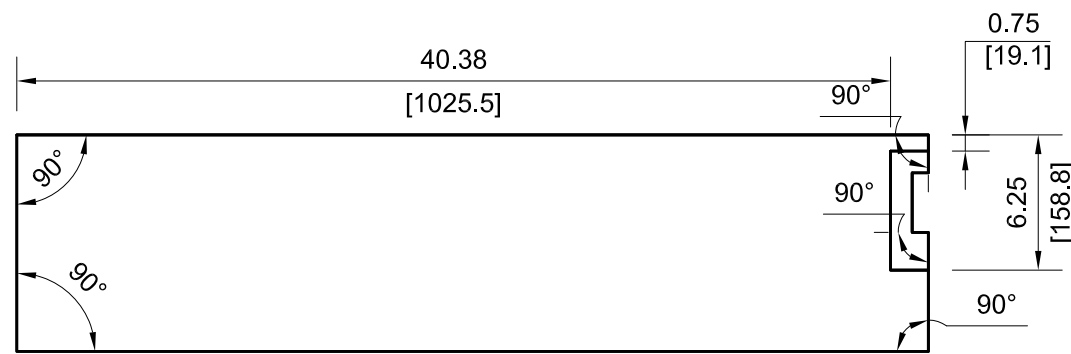
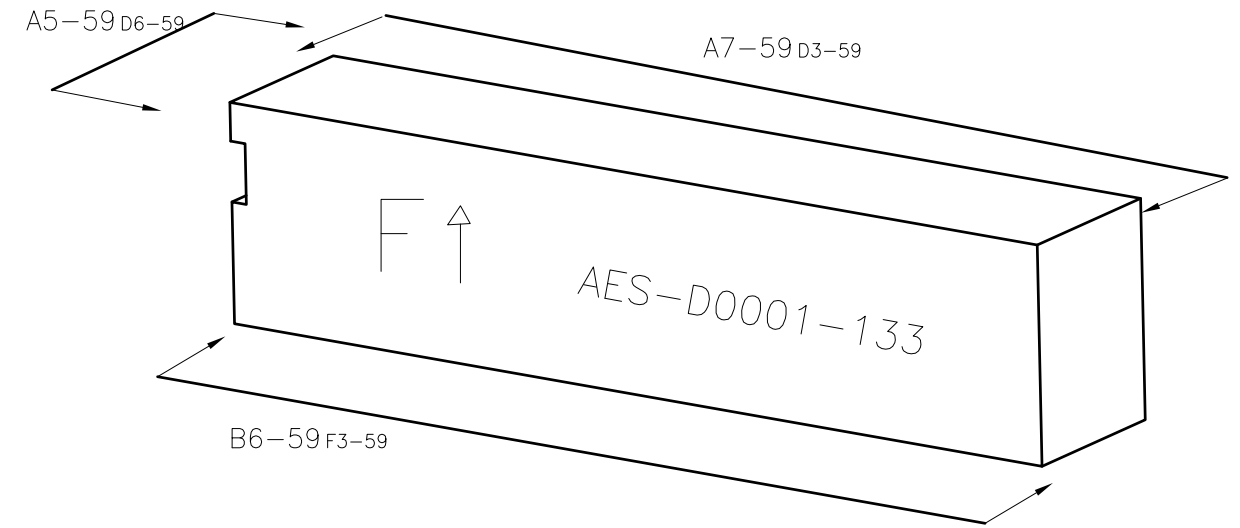

VIEW A7-59

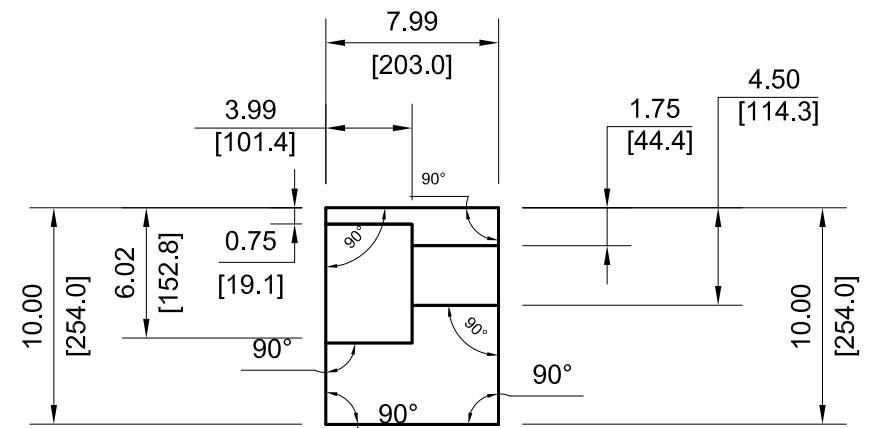

VIEW A5-59

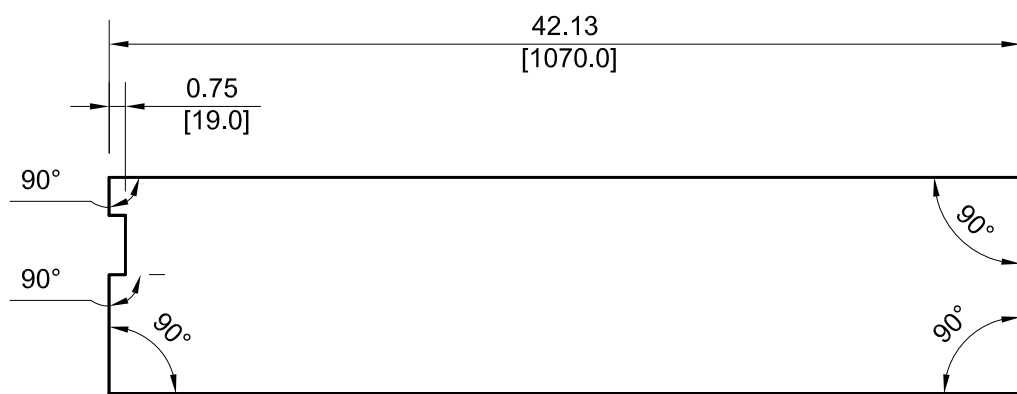

VIEW B6-59

NOTE: ALL VIEWS TAKEN AS TRUE VIEWS PARALLEL TO SURFACE OF PART



DRAWING NUMBER					AES-D0001	
SIZE	SCALE	SHEET	OF	REVISION		
A3	NONE	59	124	E		

135

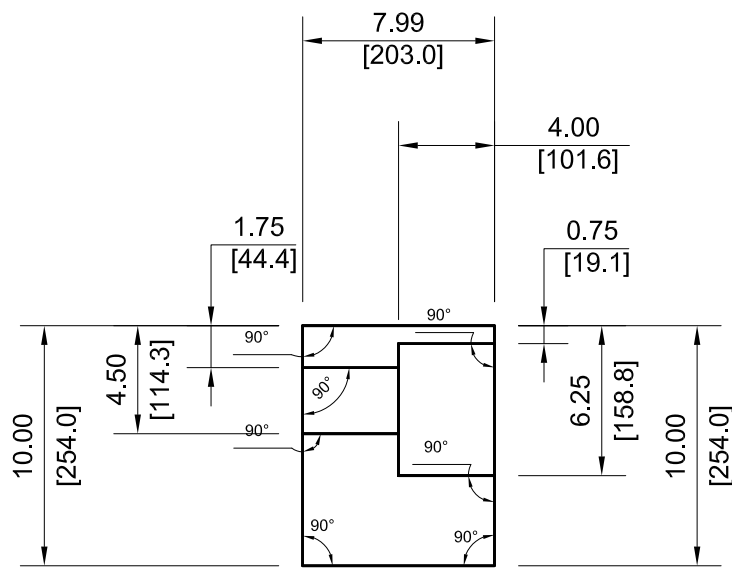
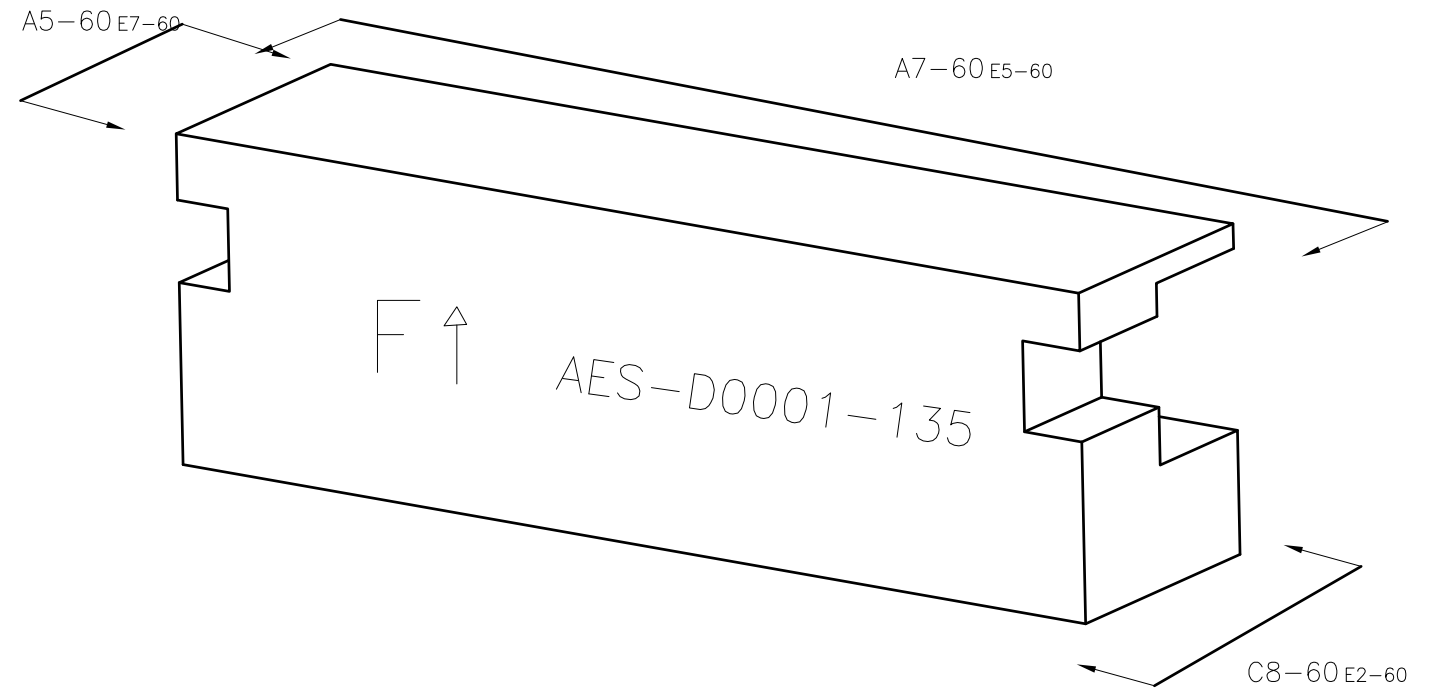

VIEW C8-60

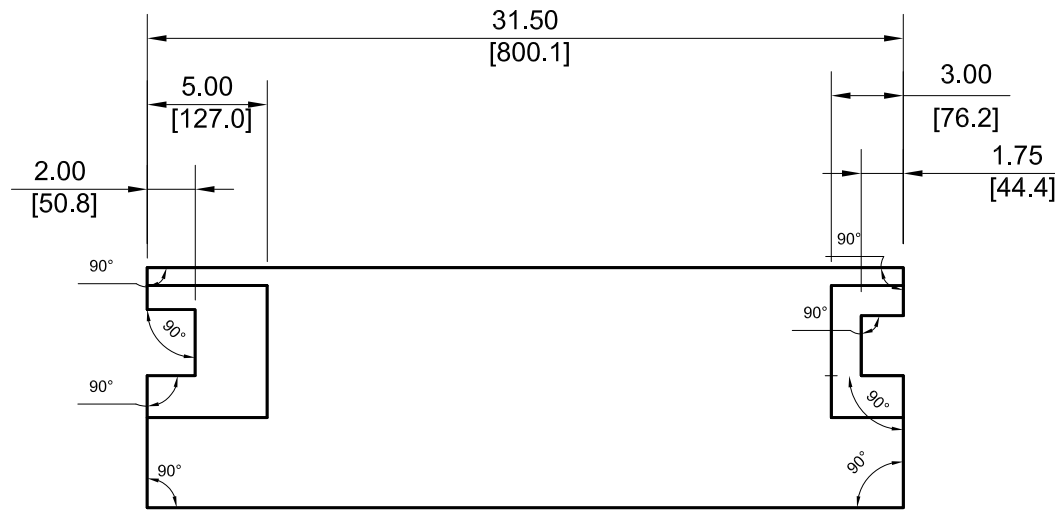

VIEW A7-60

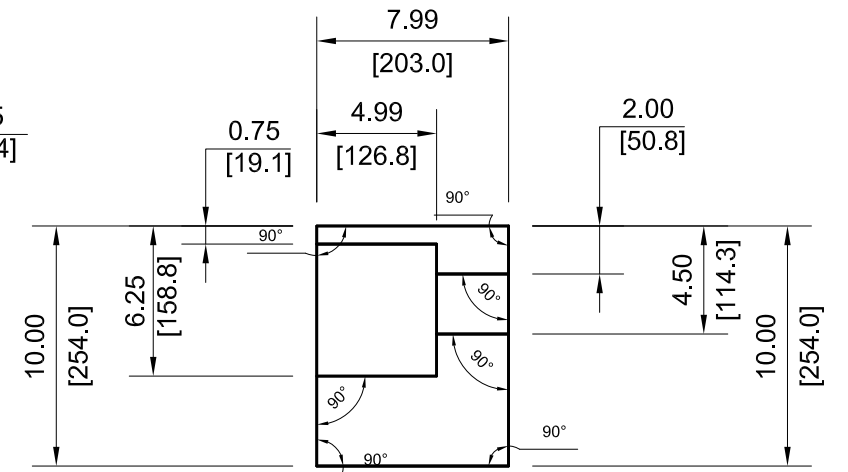

VIEW A5-60

NOTE: ALL VIEWS TAKEN AS TRUE VIEWS PARALLEL TO SURFACE OF PART

	DRAWING NUMBER			
	AES-D0001			
SIZE	SCALE	SHEET	OF	REVISION
A3	NONE	60	124	E

— 137

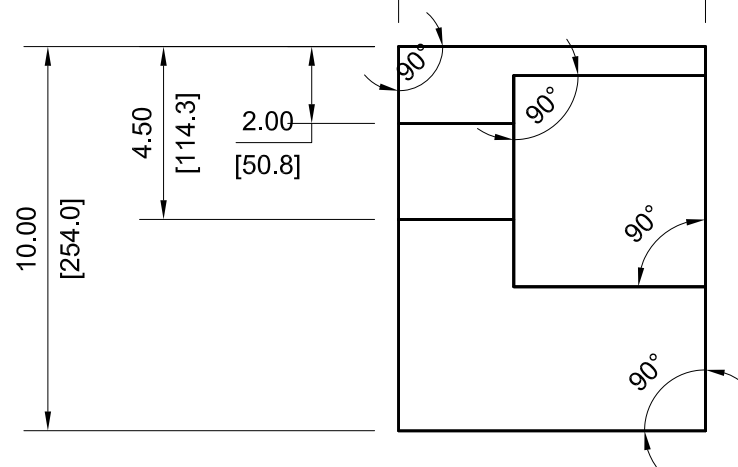
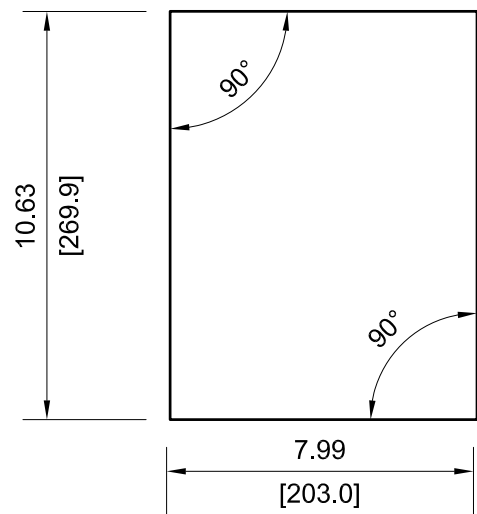
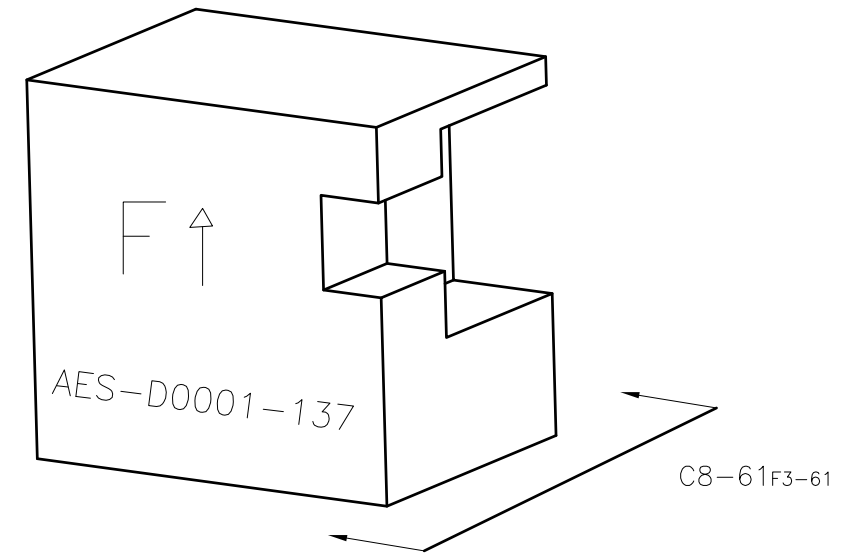

VIEW C8-61

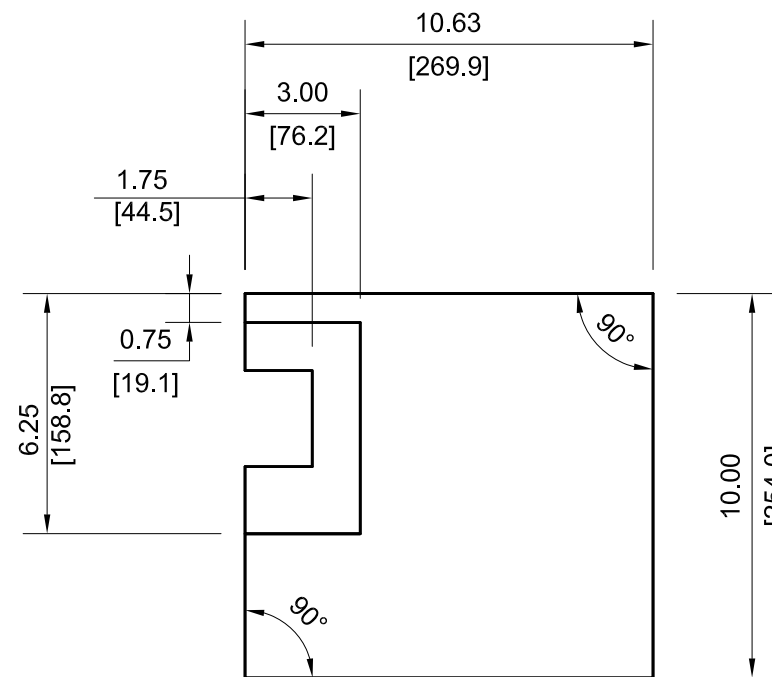

NOTE: ALL VIEWS TAKEN AS TRUE VIEWS PARALLEL TO SURFACE OF PART



DRAWING NUMBER					AES-D0001				
SIZE	SCALE	SHEET	OF	REVISION					
A3	NONE	61	124	E					

-139

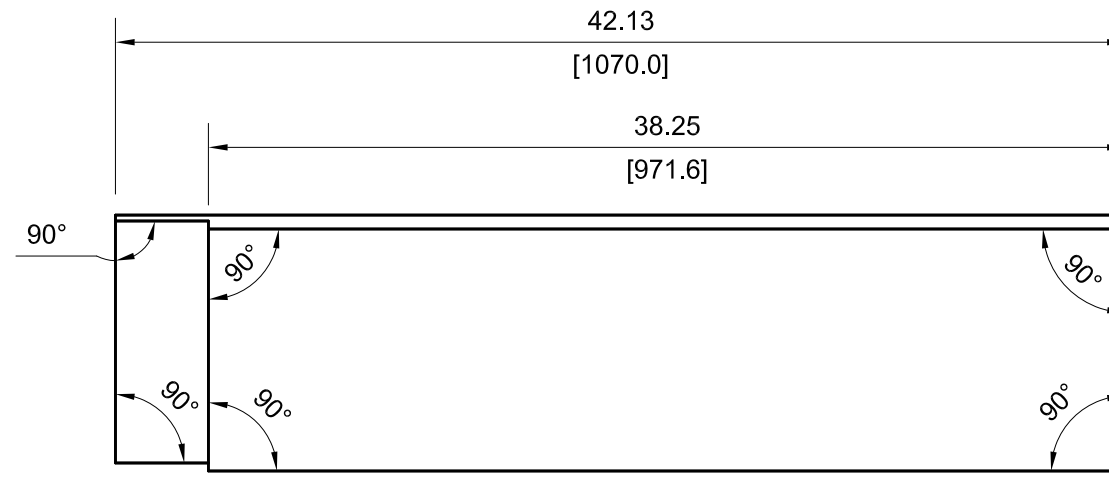
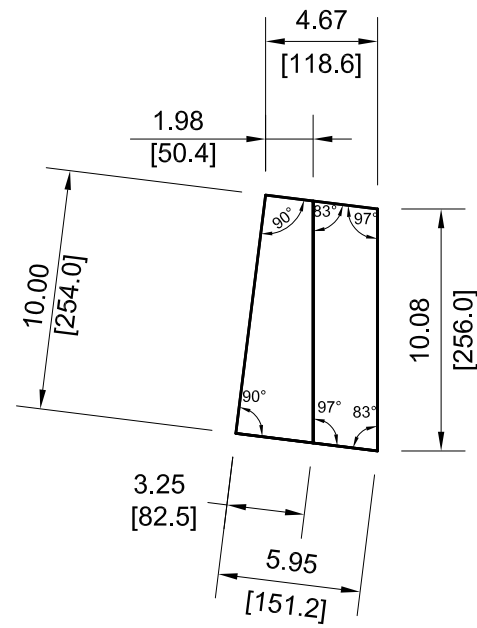
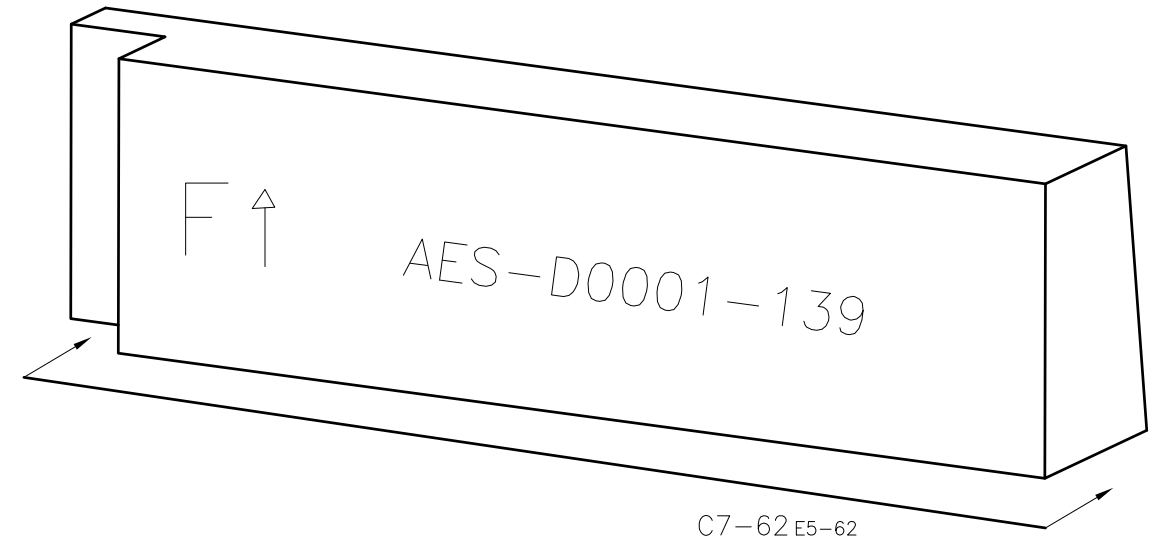

VIEW C7-62

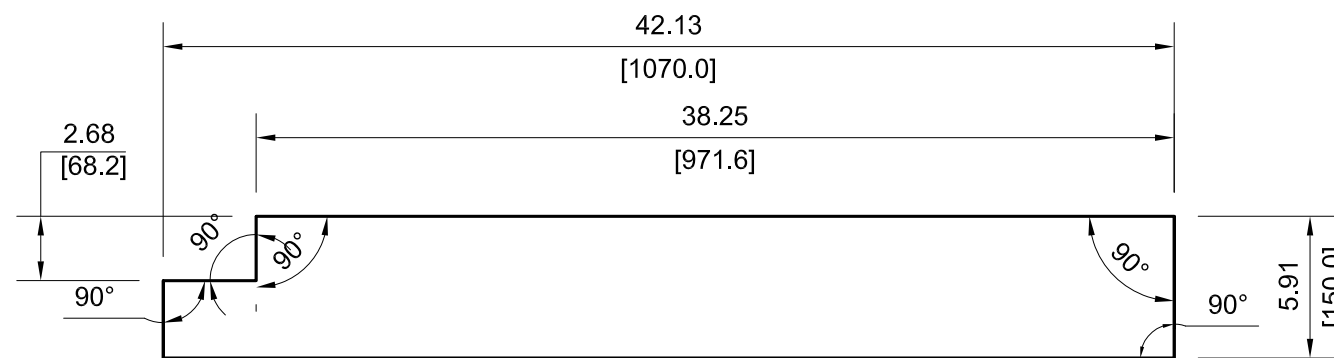

NOTE: ALL VIEWS TAKEN AS TRUE VIEWS PARALLEL TO SURFACE OF PART



DRAWING NUMBER					AES-D0001	
SIZE	SCALE	SHEET	OF	REVISION		
A3	NONE	62	124	E		

141

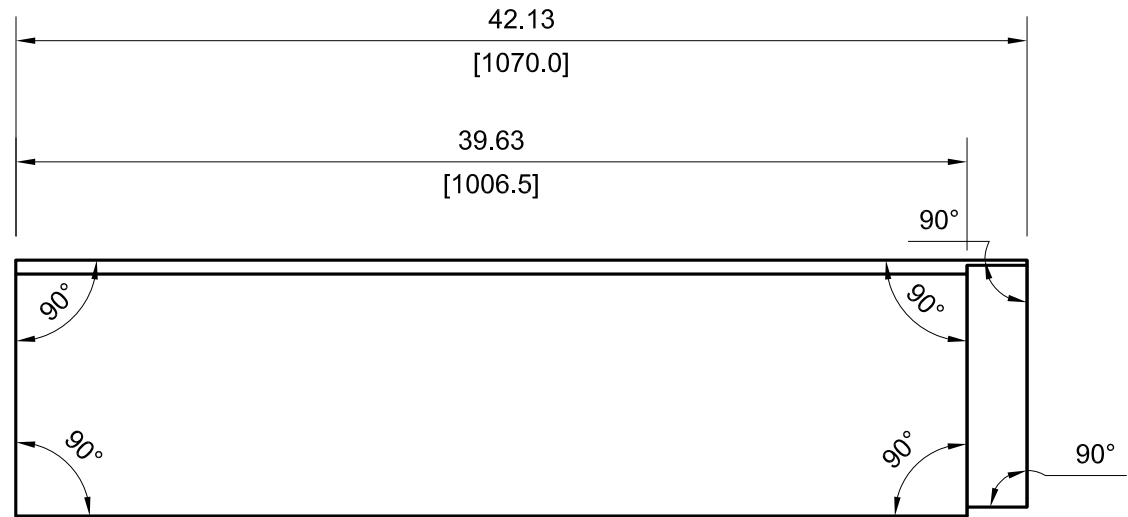
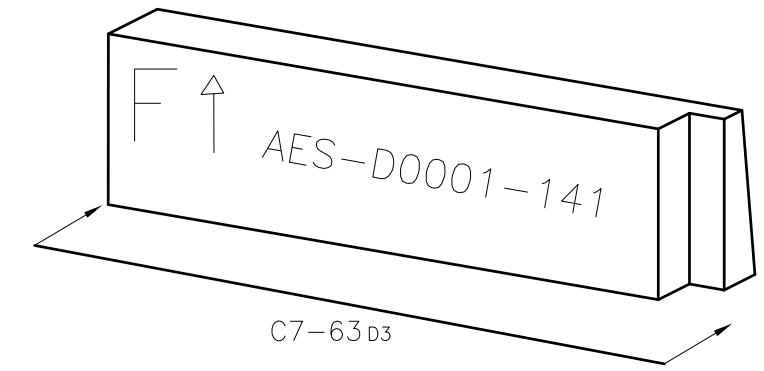

VIEW C7-63

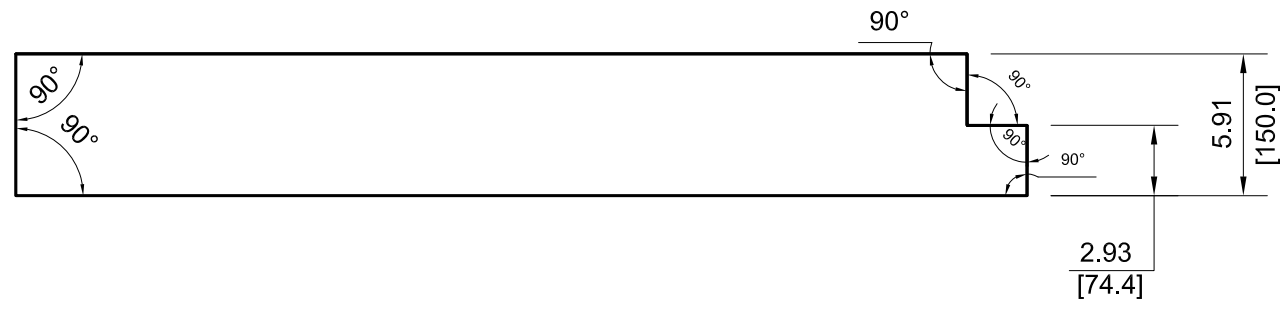
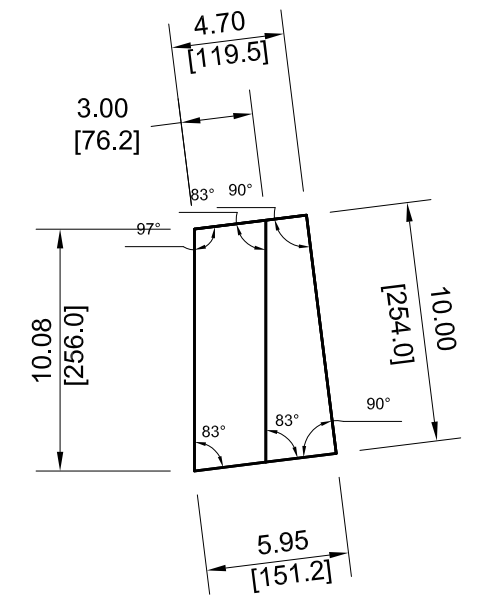

NOTE: ALL VIEWS TAKEN AS TRUE VIEWS PARALLEL TO SURFACE OF PART

		DRAWING NUMBER			
		AES-D0001			
SIZE	SCALE	SHEET	OF	REVISION	
A3	NONE	63	124	E	

143

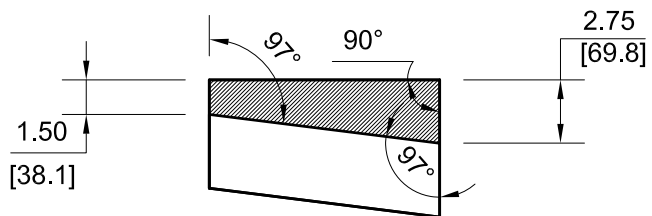

SECTION VIEW B3-64

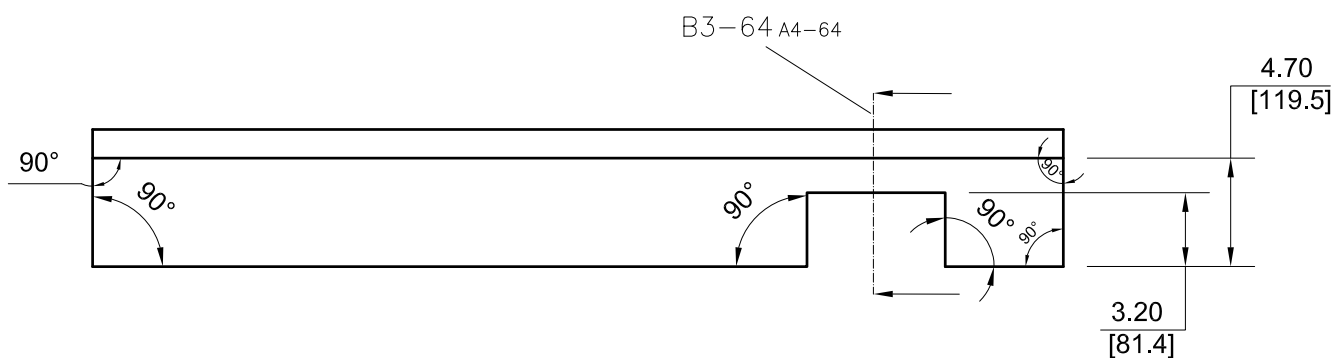

B3-64 A4-64

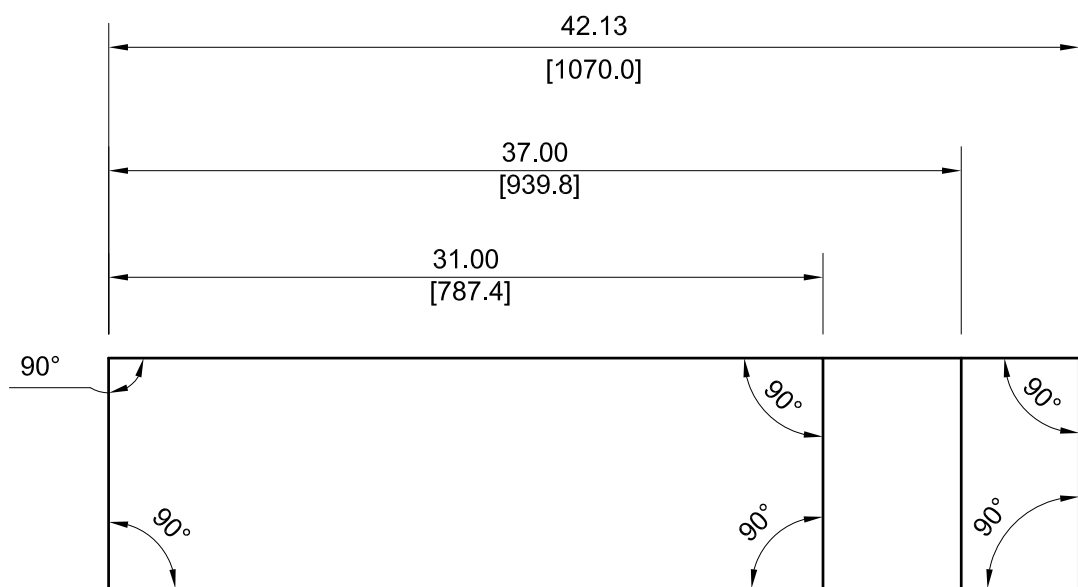
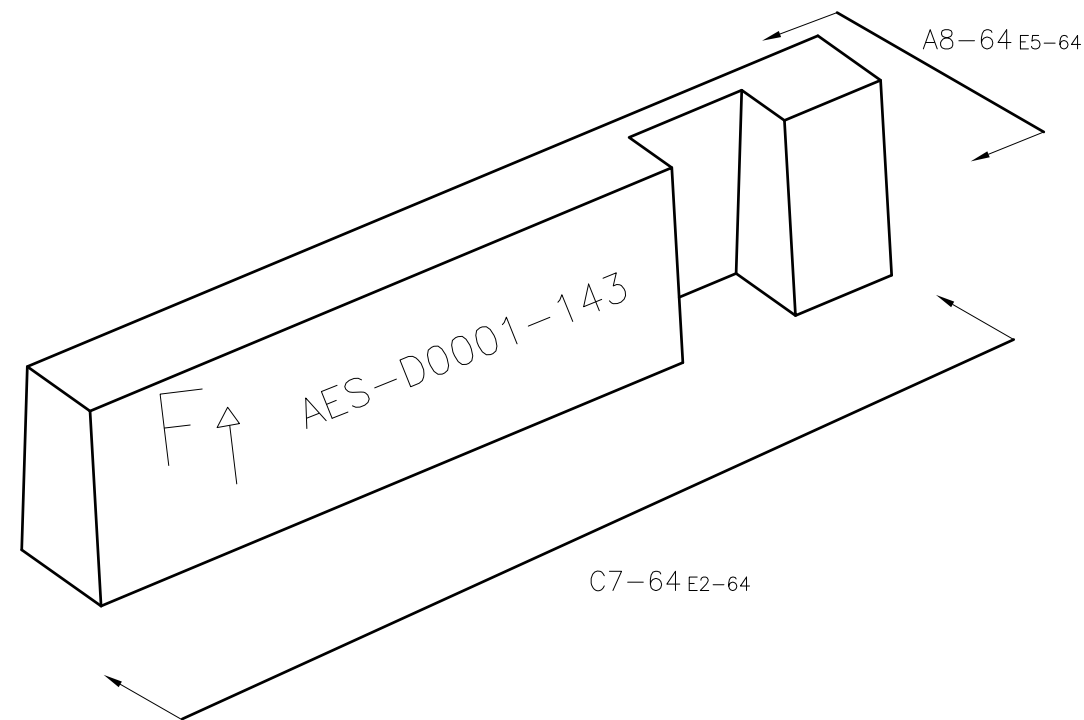

VIEW C7-64

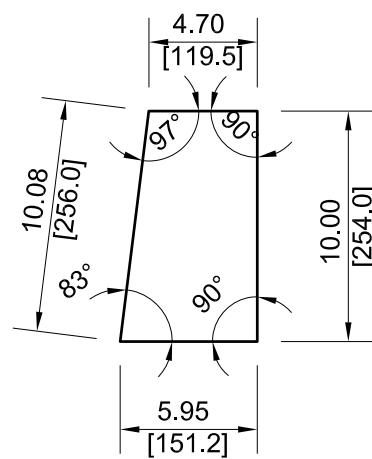

VIEW A8-64

NOTE: ALL VIEWS TAKEN AS TRUE VIEWS PARALLEL TO SURFACE OF PART



DRAWING NUMBER					AES-D0001	
SIZE	SCALE	SHEET	OF	REVISION		
A3	NONE	64	124	E		

145

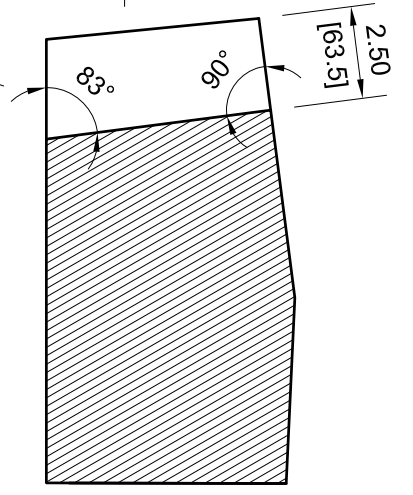
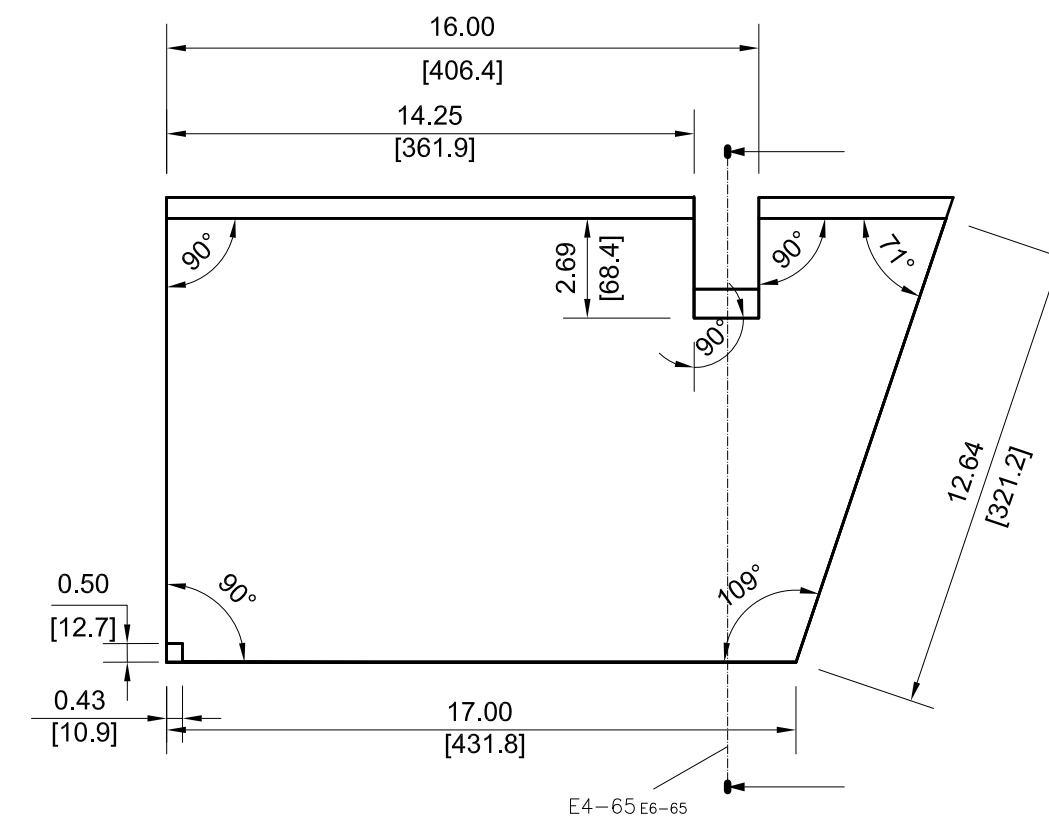
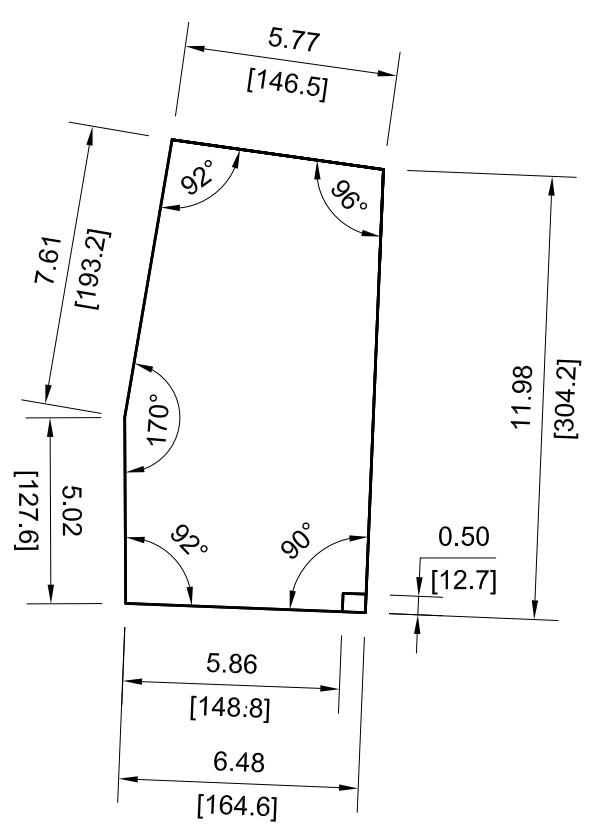
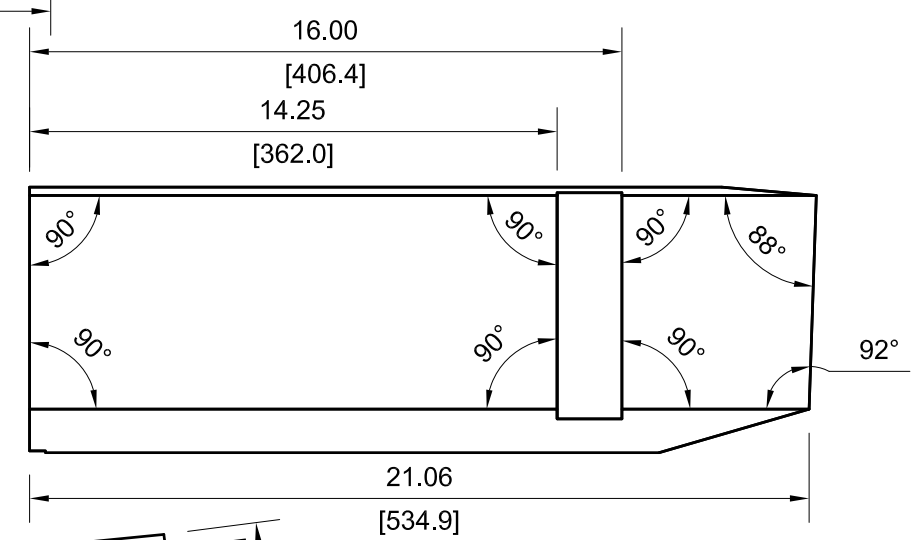
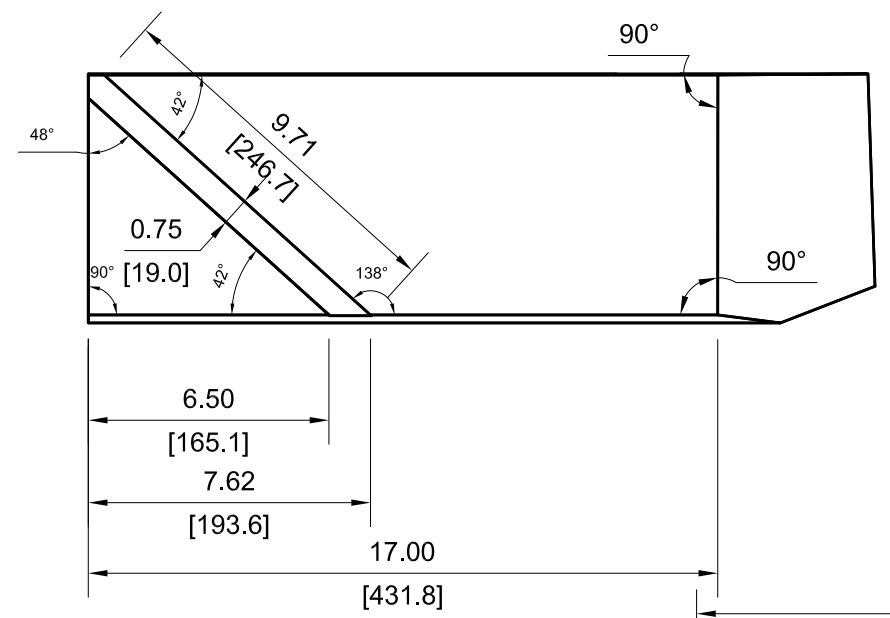
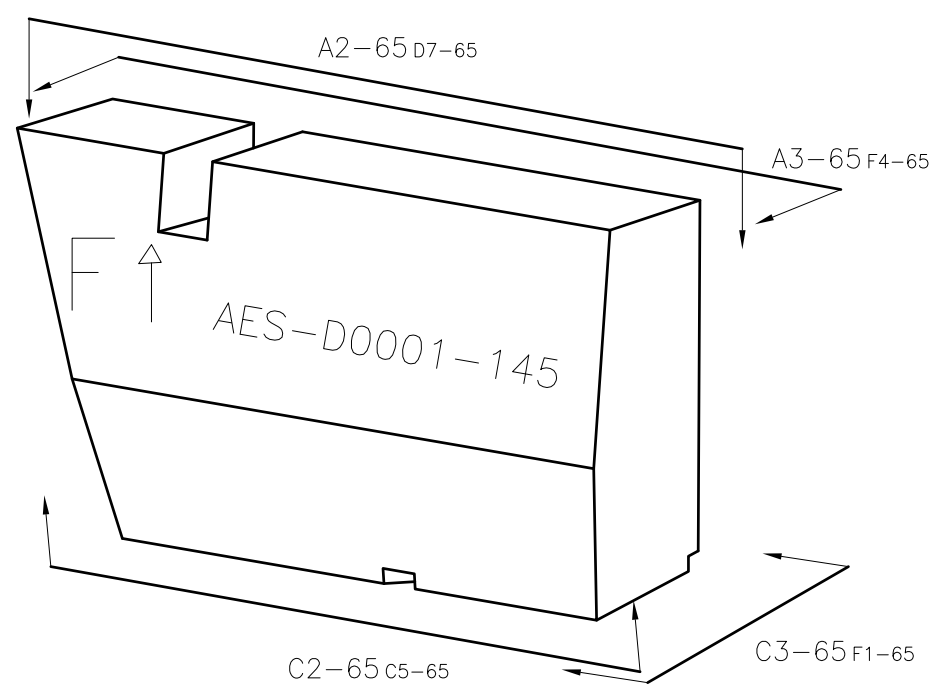

NOTE: ALL VIEWS TAKEN AS TRUE VIEWS PARALLEL TO SURFACE OF PART

		DRAWING NUMBER			
		AES-D0001			
SIZE	SCALE	SHEET	OF	REVISION	
A3	NONE	65	124	E	

147

SECTION VIEW C5-66

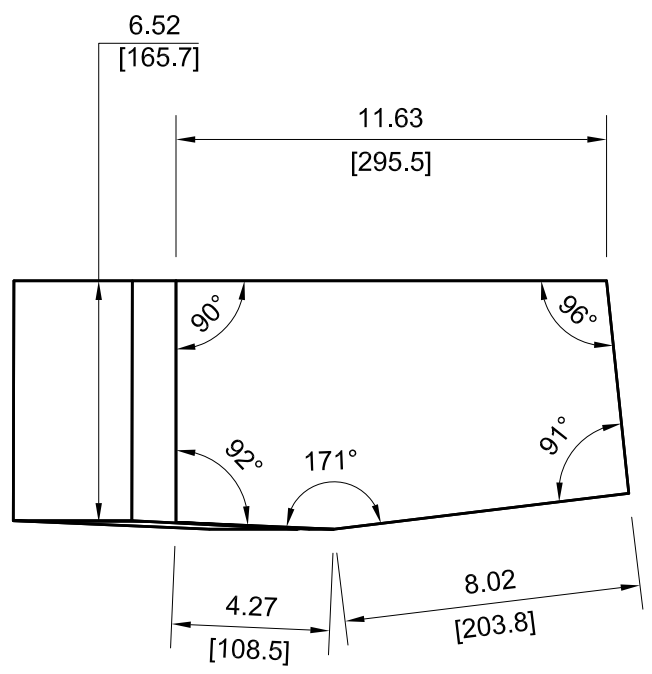
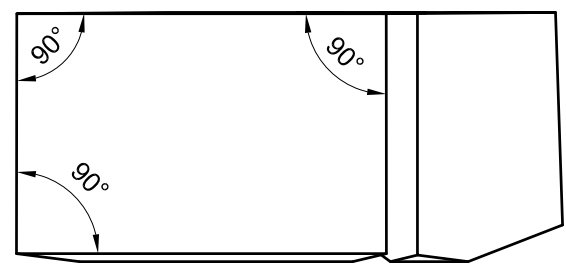
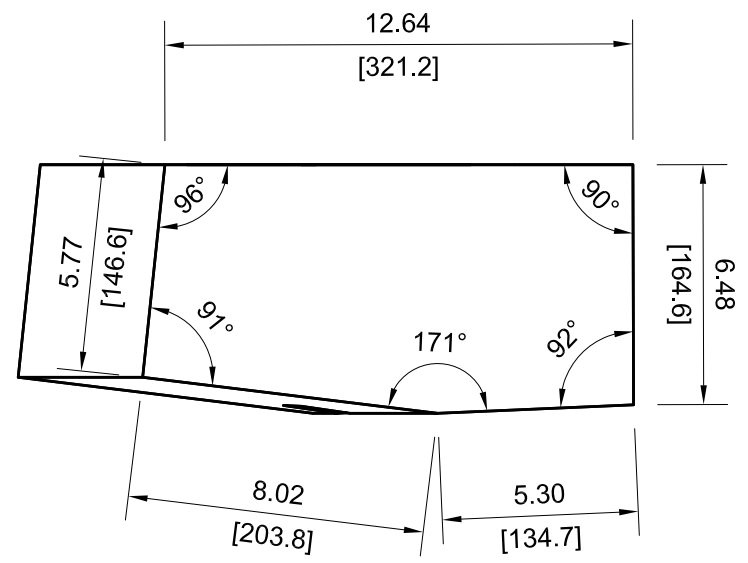
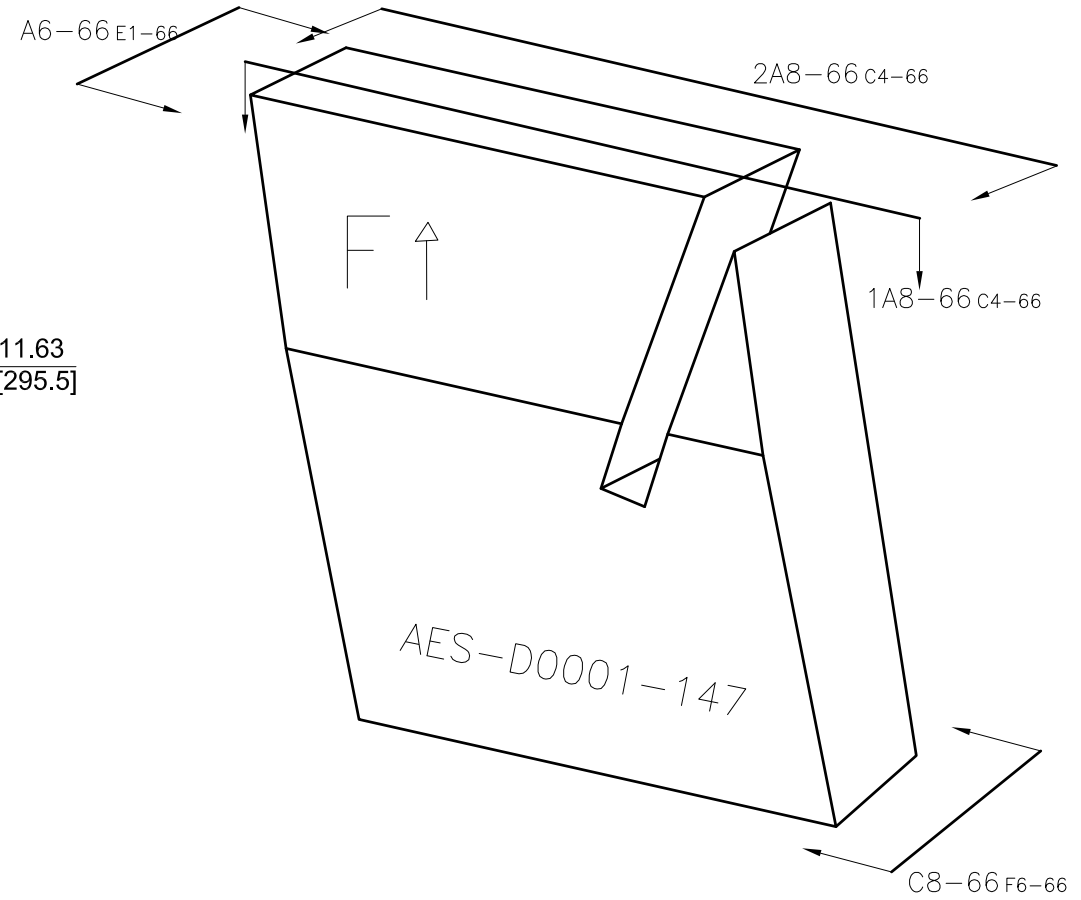
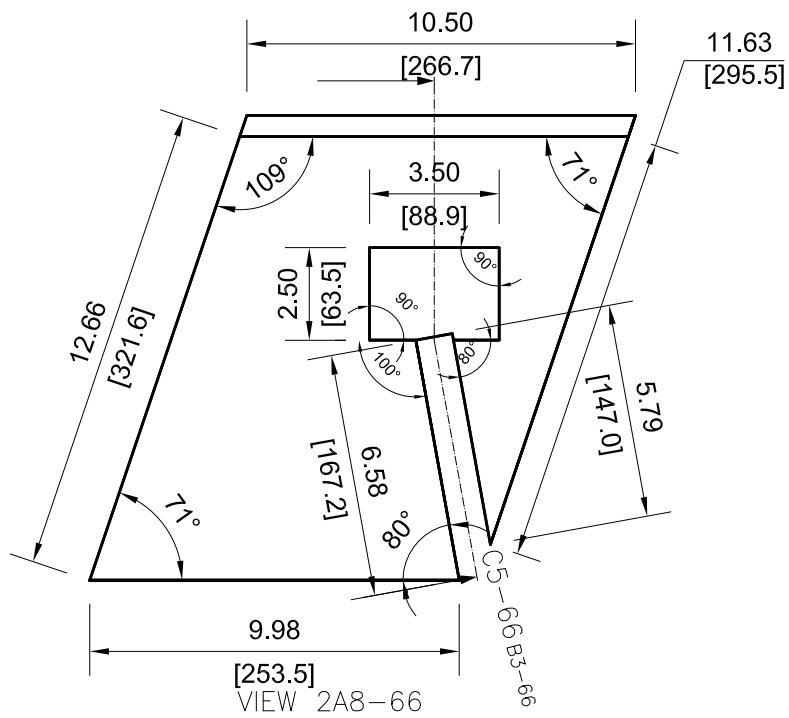
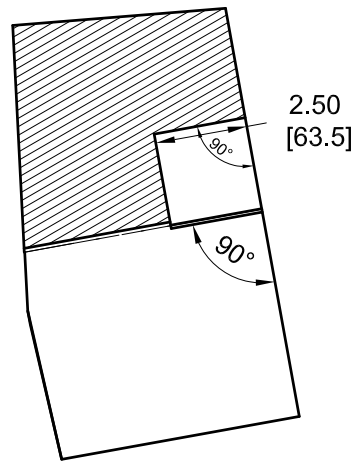

NOTE: ALL VIEWS TAKEN AS TRUE VIEWS PARALLEL TO SURFACE OF PART

		DRAWING NUMBER			
		AES-D0001			
SIZE	SCALE	SHEET	OF	REVISION	
A3	NONE	66	124	E	

1 2 3 4 5 6 7 8

A  
B  
C  
D  
E  
F

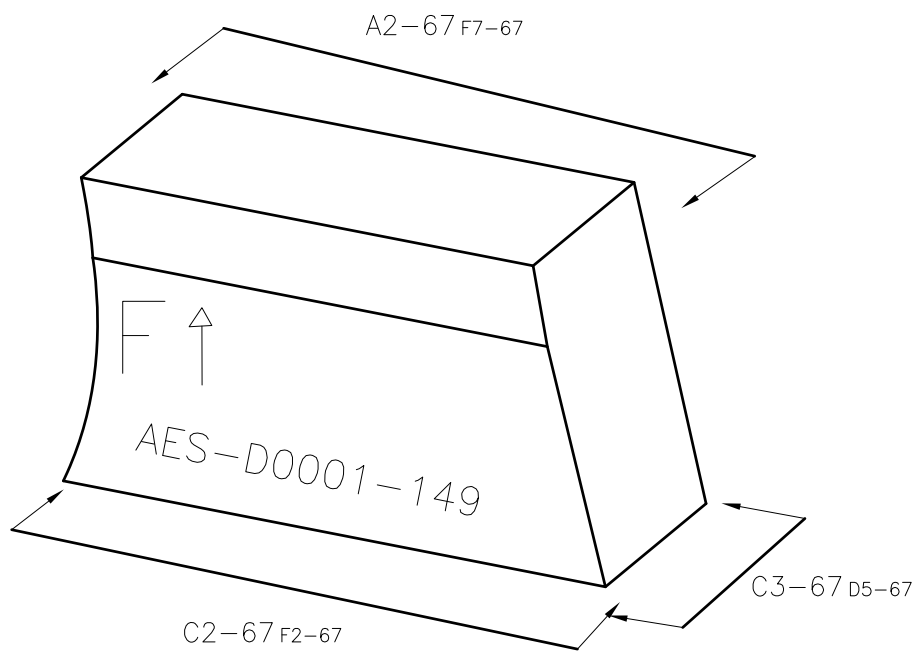

149

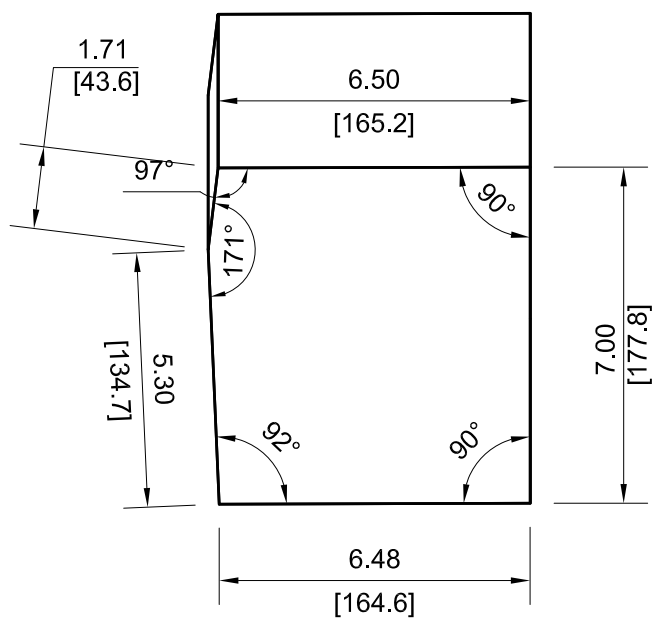

VIEW C3-67

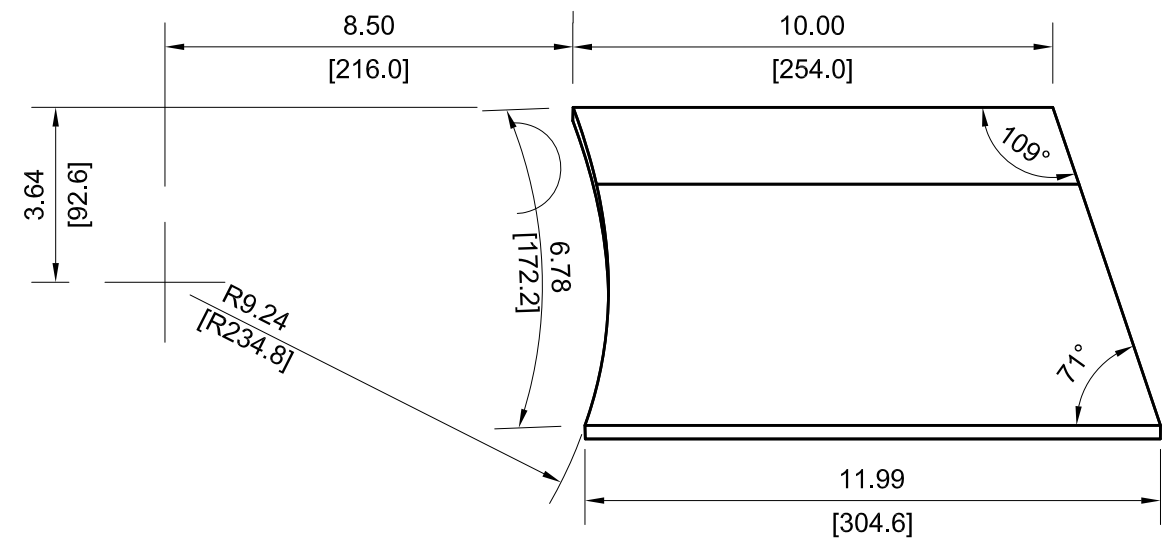

VIEW C2-67

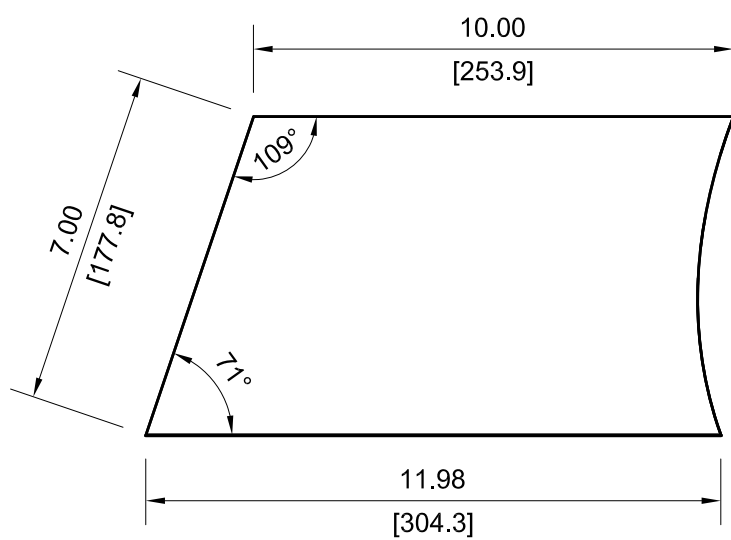

VIEW A2-67

NOTE: ALL VIEWS TAKEN AS TRUE VIEWS PARALLEL TO SURFACE OF PART



DRAWING NUMBER					AES-D0001	
SIZE	SCALE	SHEET	OF	REVISION		
A3	NONE	67	124	E		

1 2 3 4 5 6 7 8

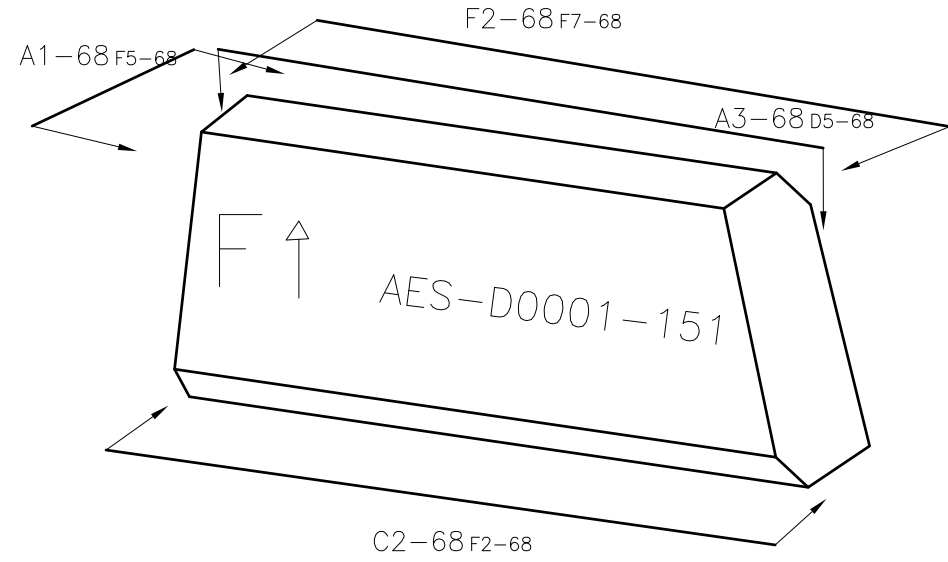

151

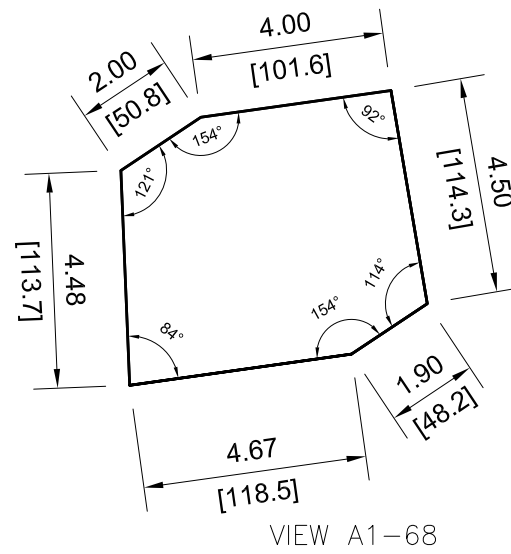
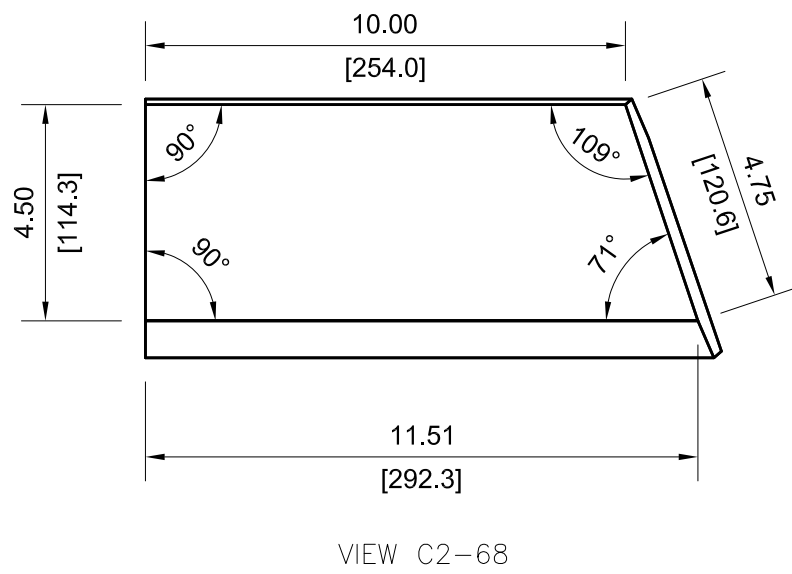
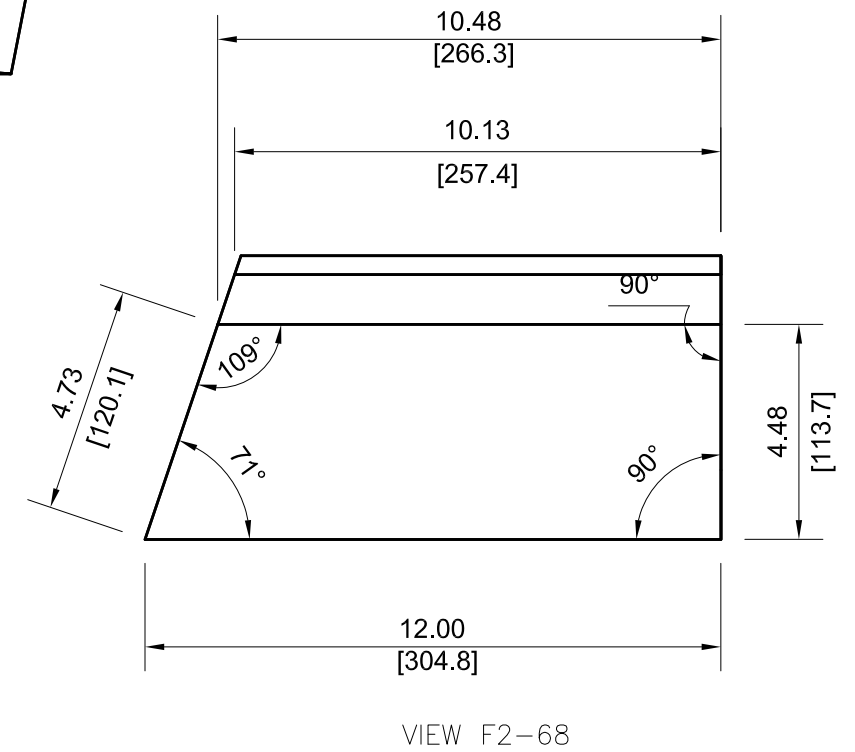
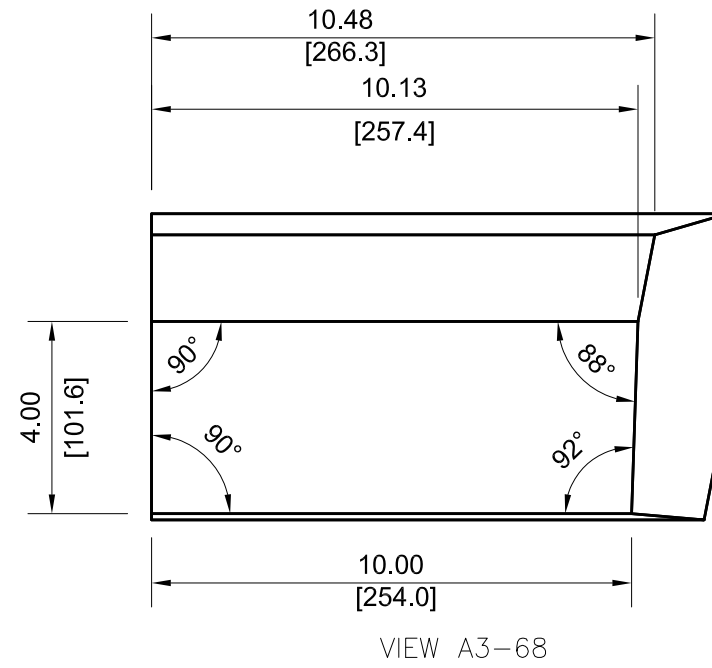

NOTE: ALL VIEWS TAKEN AS TRUE VIEWS PARALLEL TO SURFACE OF PART

	DRAWING NUMBER			
	AES-D0001			
SIZE	SCALE	SHEET	OF	REVISION
A3	NONE	68	124	E

# 153

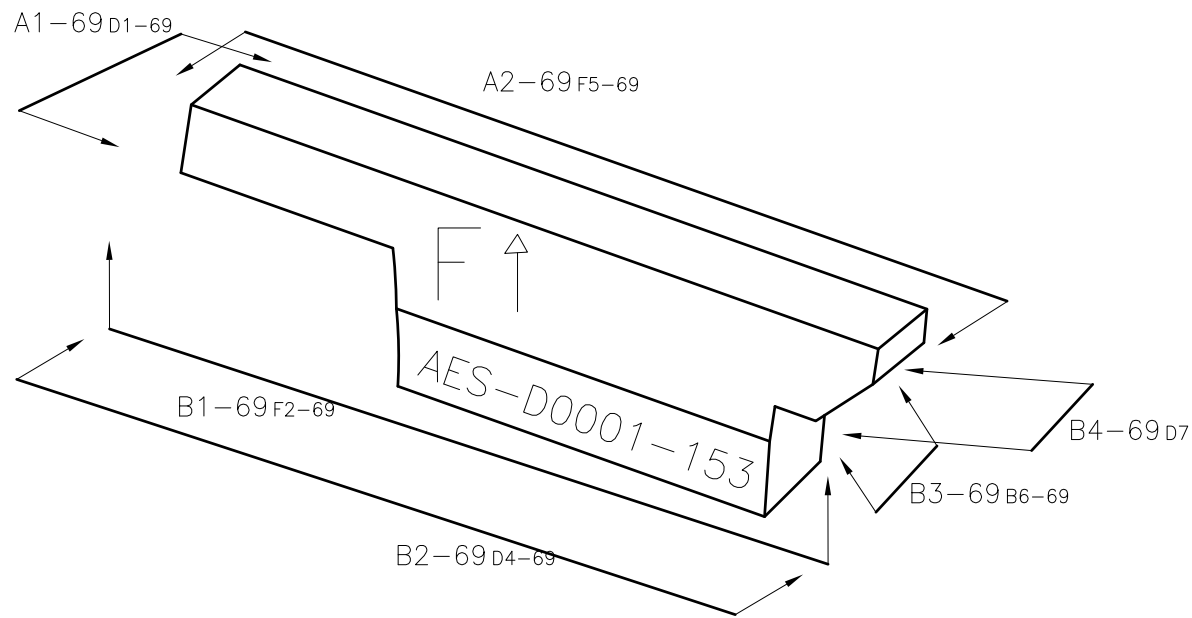

VIEW B3-69

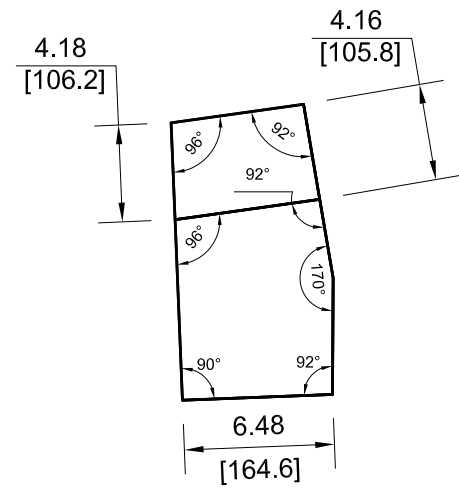

VIEW A1-69

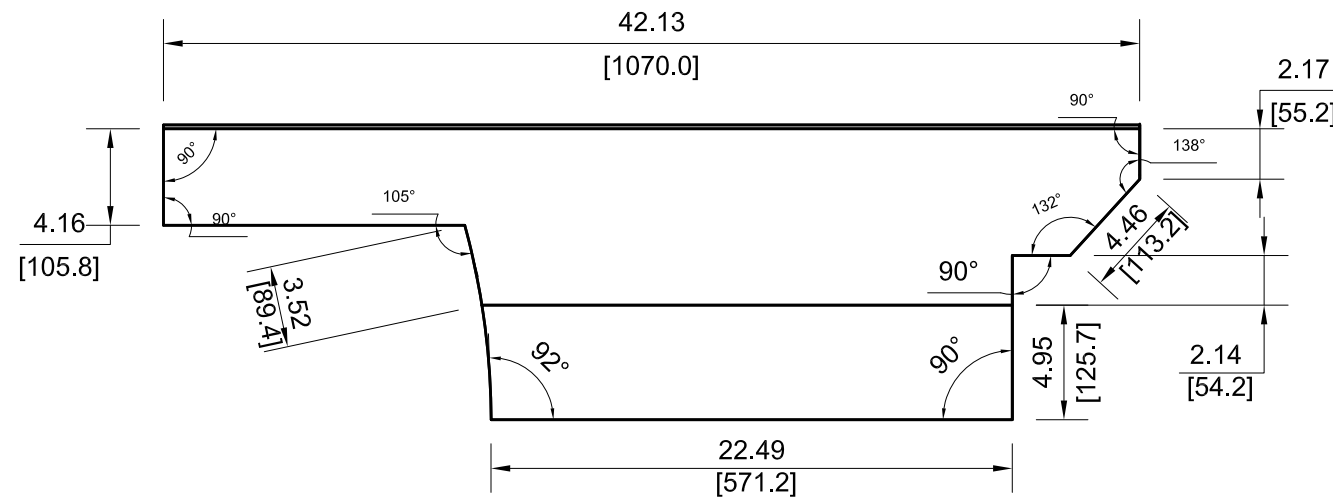

VIEW B2-69

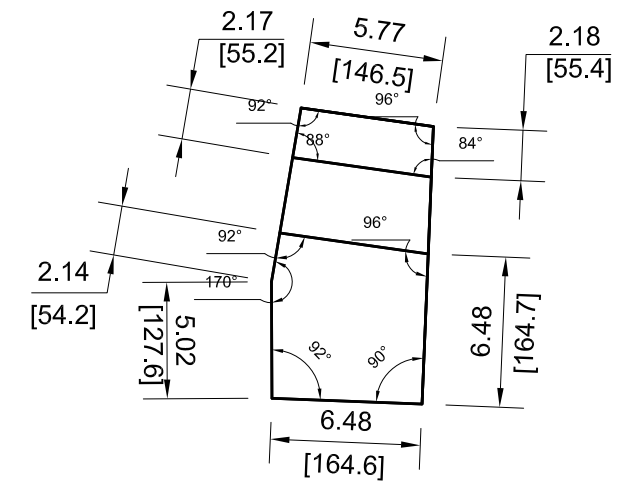

VIEW B4-69

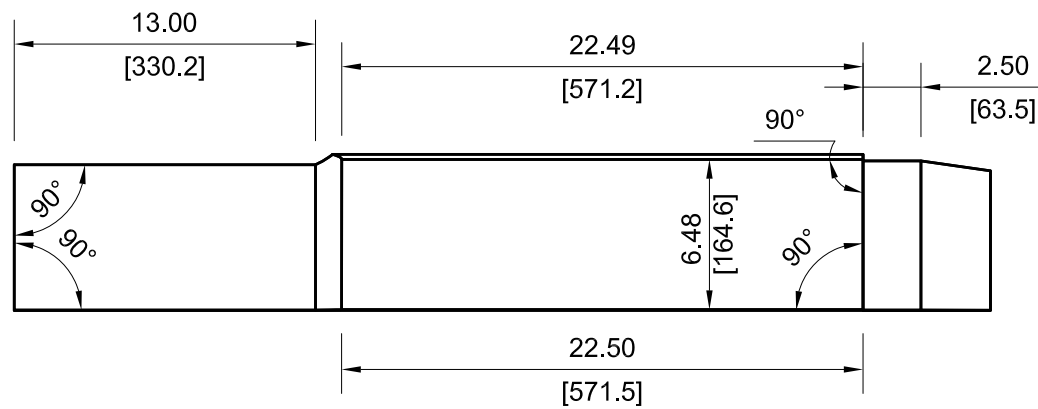

VIEW B1-69

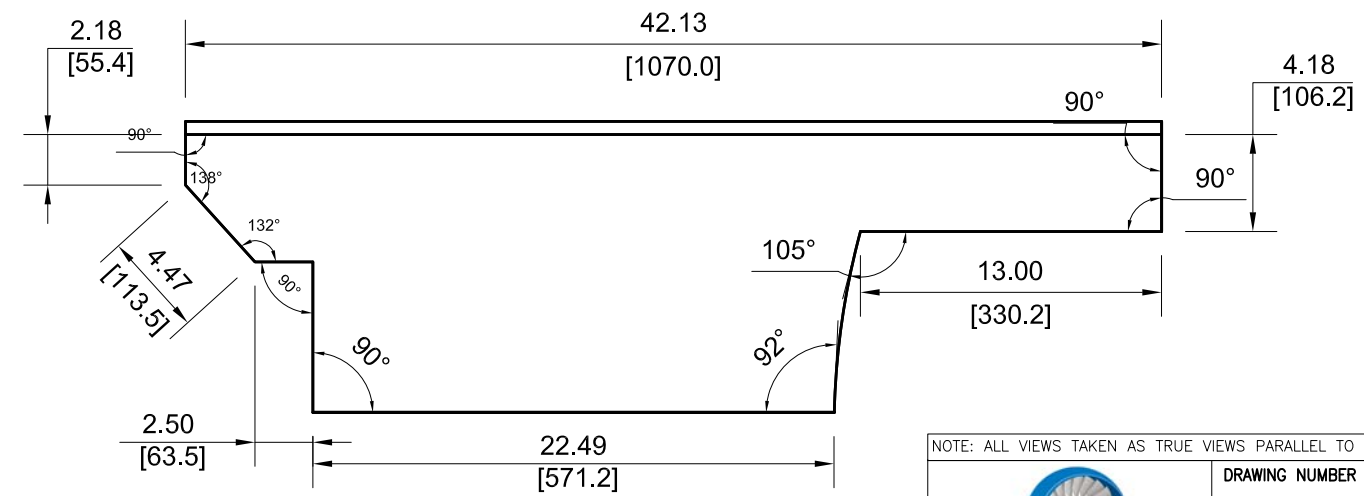

VIEW A2-69

NOTE: ALL VIEWS TAKEN AS TRUE VIEWS PARALLEL TO SURFACE OF PART

		DRAWING NUMBER			
		AES-D0001			
SIZE	SCALE	SHEET	OF	REVISION	
A3	NONE	69	124	E	

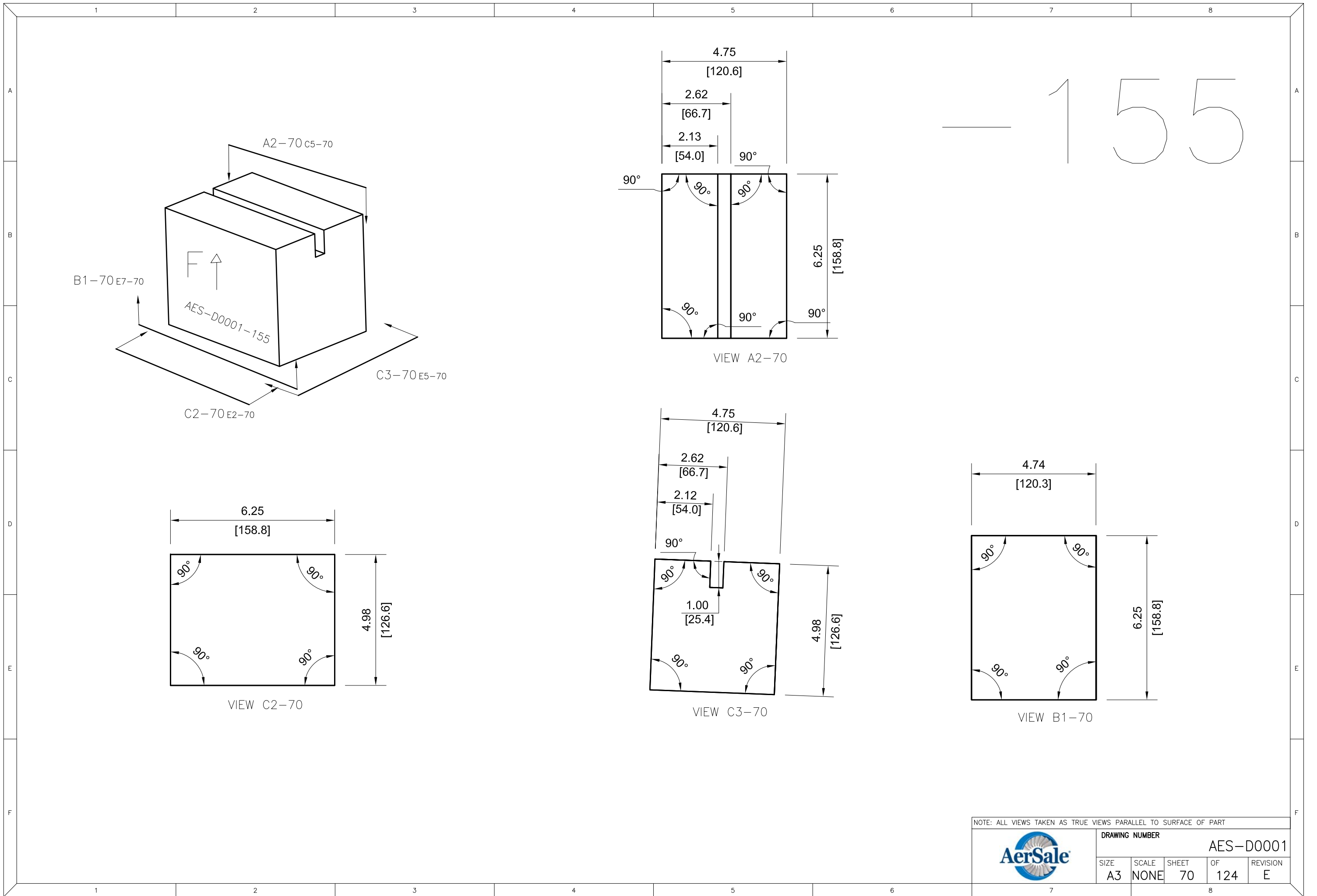

NOTE: ALL VIEWS TAKEN AS TRUE VIEWS PARALLEL TO SURFACE OF PART



DRAWING NUMBER					AES-D0001				
SIZE	SCALE	SHEET	OF	REVISION					
A3	NONE	70	124	E					

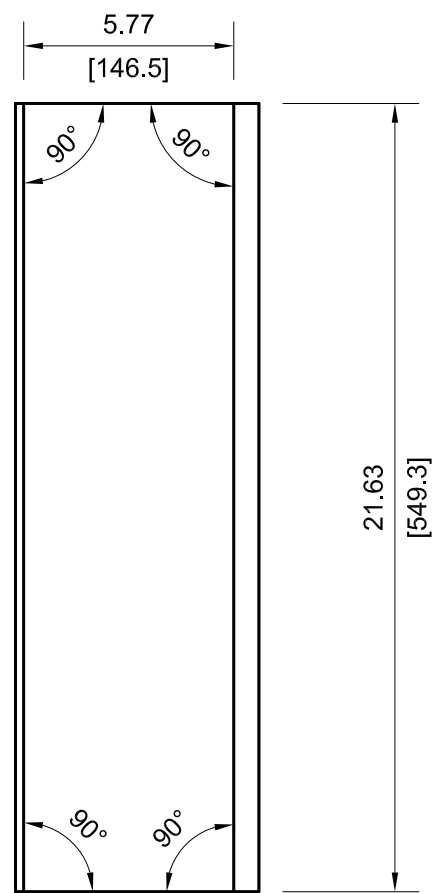
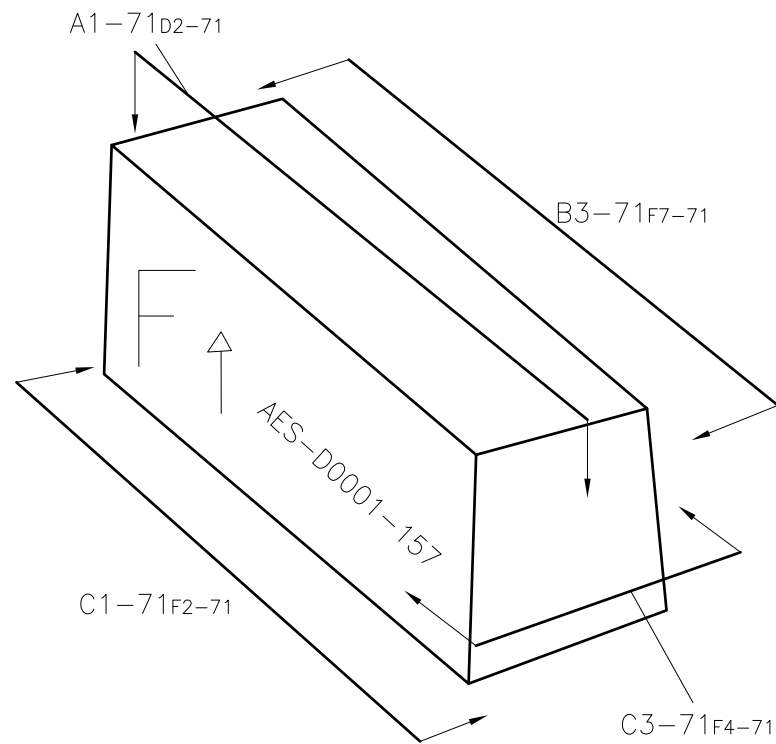

VIEW A1-71

157

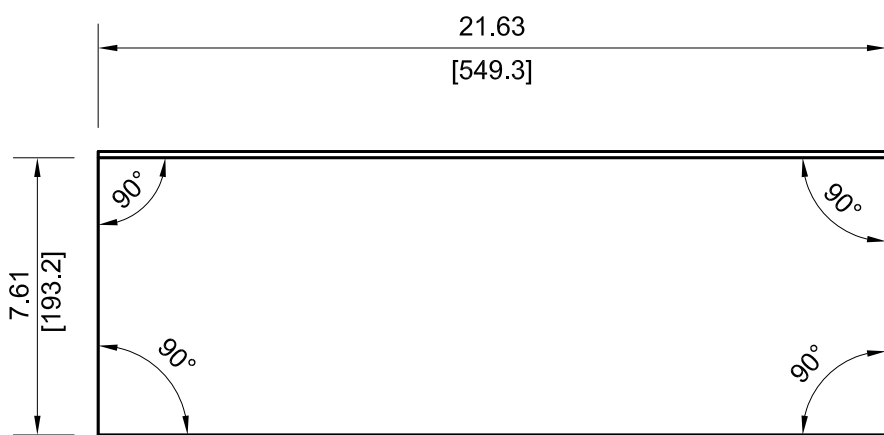

VIEW C1-71

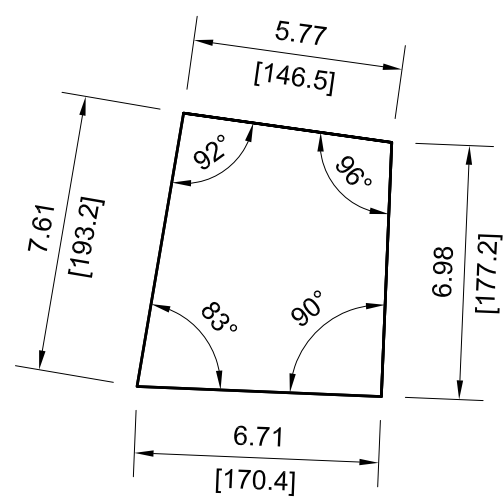

VIEW C3-71

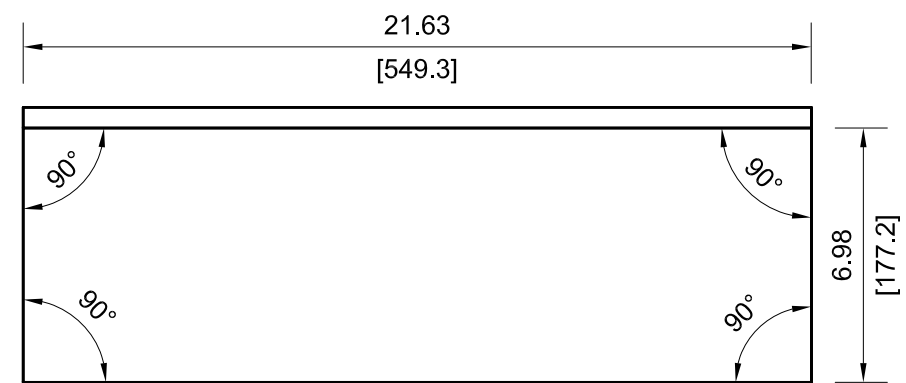

VIEW B3-71

NOTE: ALL VIEWS TAKEN AS TRUE VIEWS PARALLEL TO SURFACE OF PART



DRAWING NUMBER					AES-D0001	
SIZE	SCALE	SHEET	OF	REVISION		
A3	NONE	71	124	E		

159

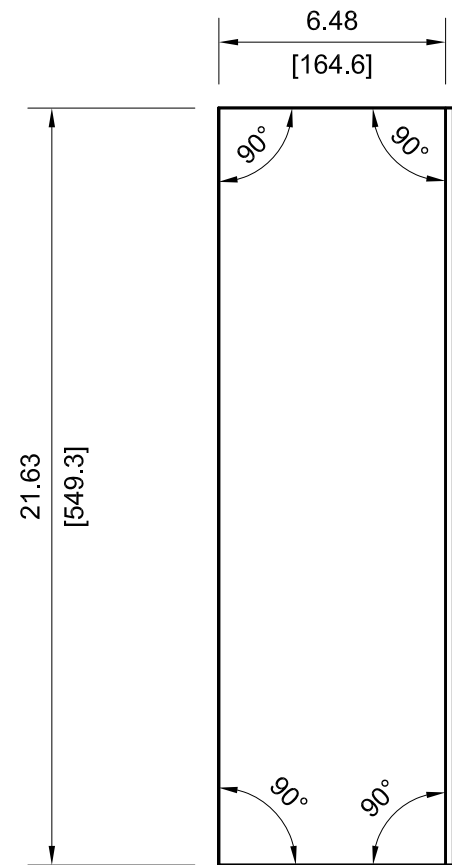

VIEW F2-72

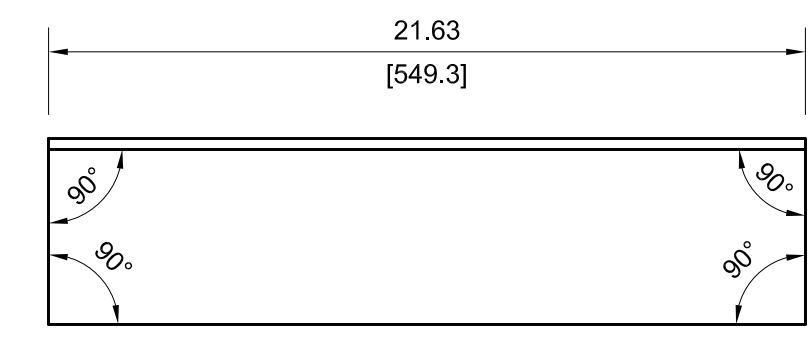
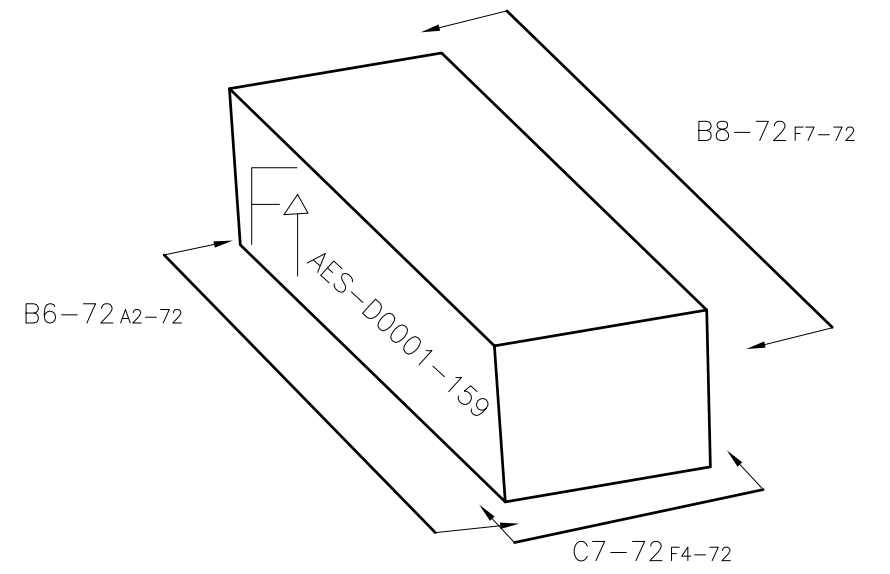

VIEW B8-72

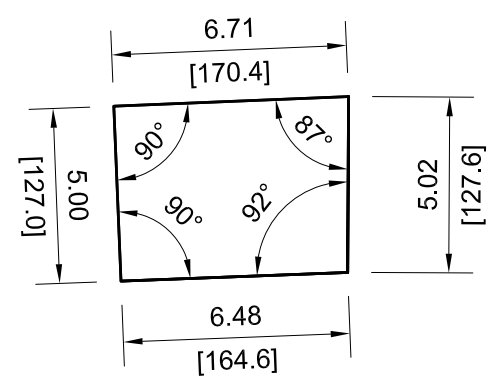

VIEW C7-72

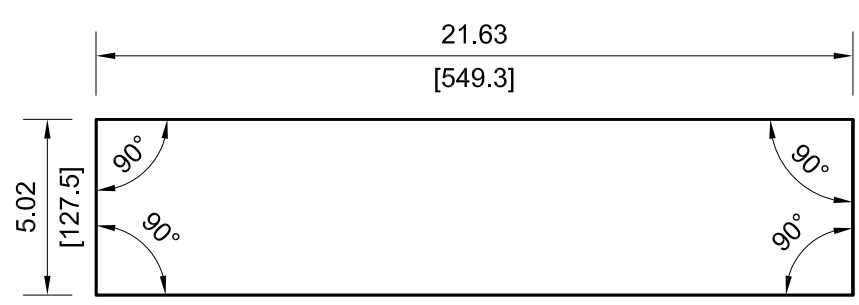

VIEW B6-72

NOTE: ALL VIEWS TAKEN AS TRUE VIEWS PARALLEL TO SURFACE OF PART



DRAWING NUMBER					AES-D0001				
SIZE	SCALE	SHEET	OF	REVISION					
A3	NONE	72	124	E					

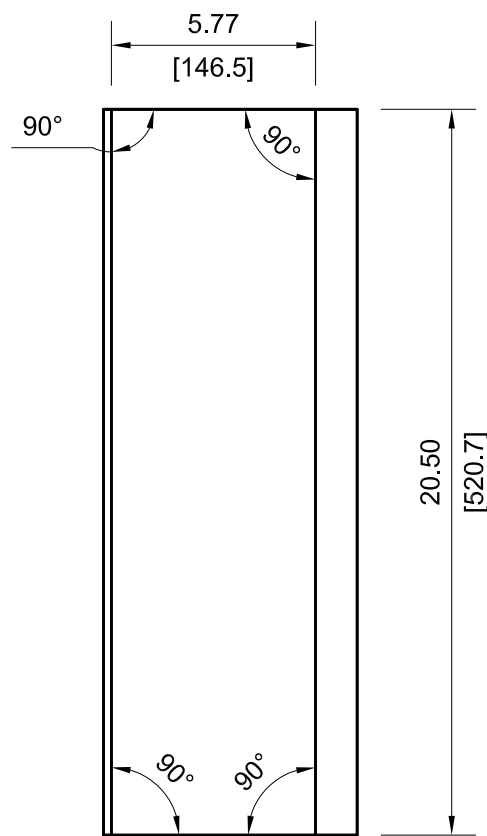

VIEW D7-73

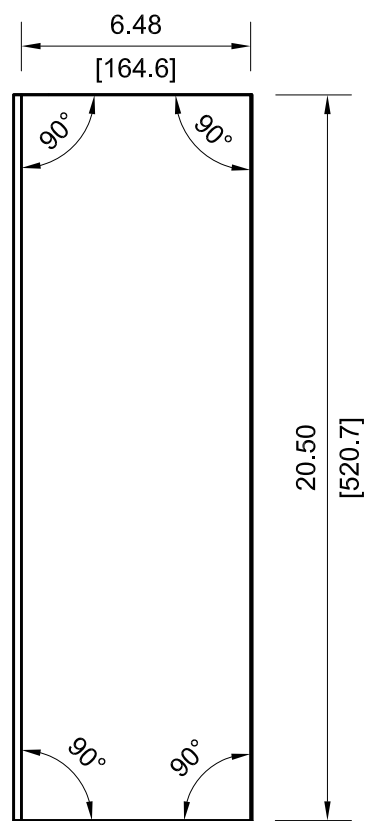

VIEW F7-73

161

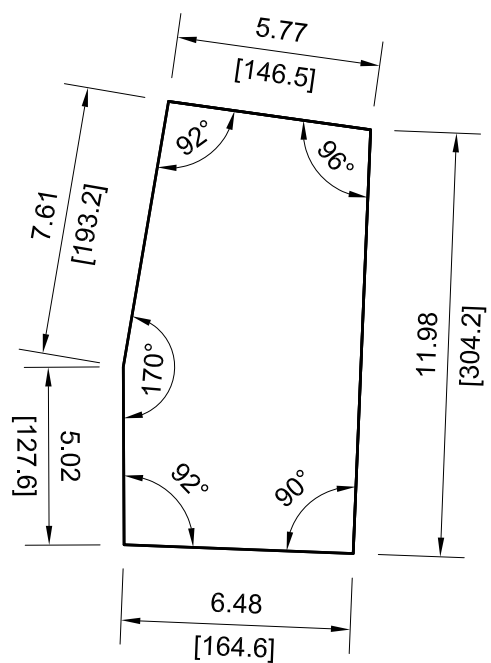

VIEW F8-73

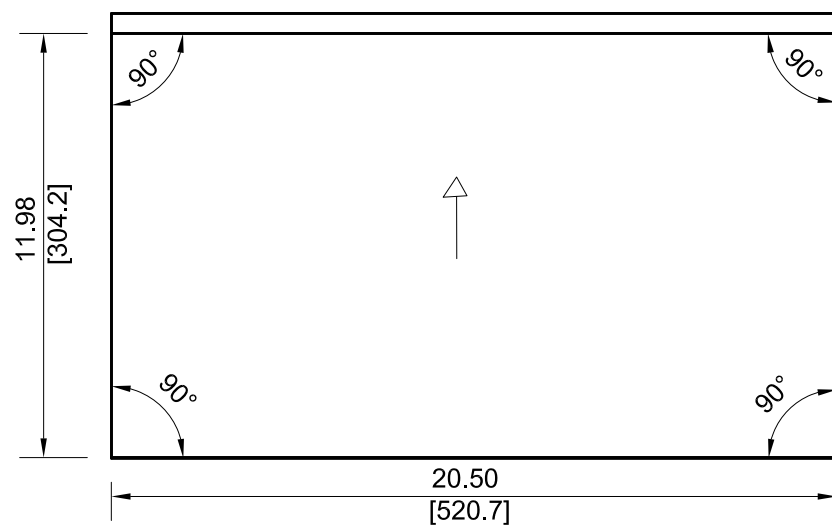

VIEW D8-73

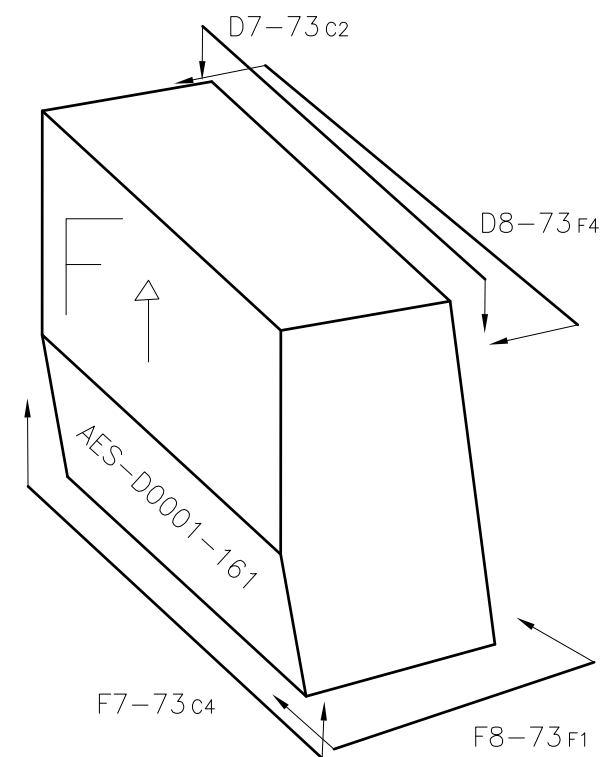

NOTE: ALL VIEWS TAKEN AS TRUE VIEWS PARALLEL TO SURFACE OF PART



DRAWING NUMBER					AES-D0001				
SIZE	SCALE	SHEET	OF	REVISION					
A3	NONE	73	124	E					

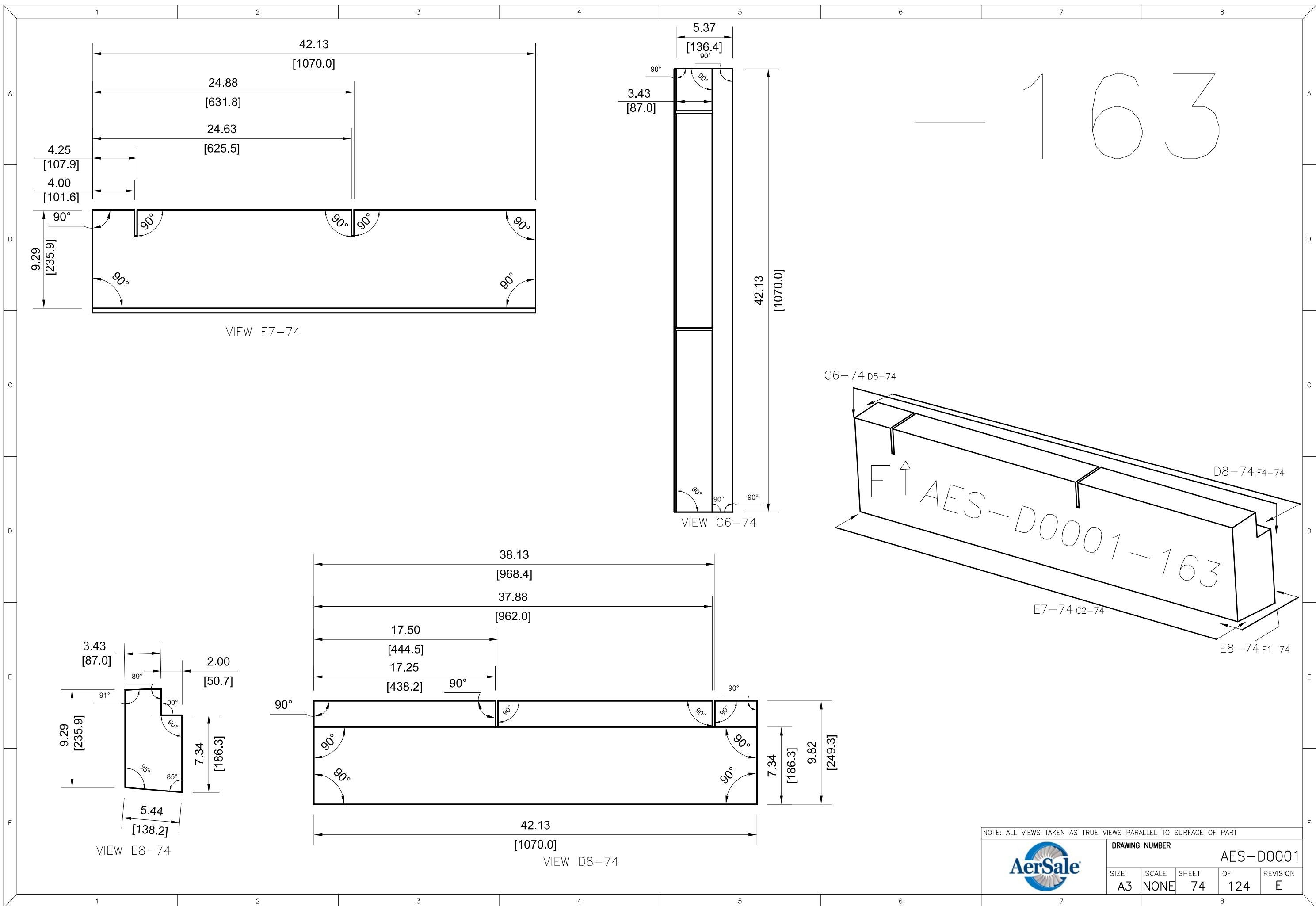

NOTE: ALL VIEWS TAKEN AS TRUE VIEWS PARALLEL TO SURFACE OF PART

	DRAWING NUMBER				
	AES-D0001				
SIZE	SCALE	SHEET	OF	REVISION	
A3	NONE	74	124	E	

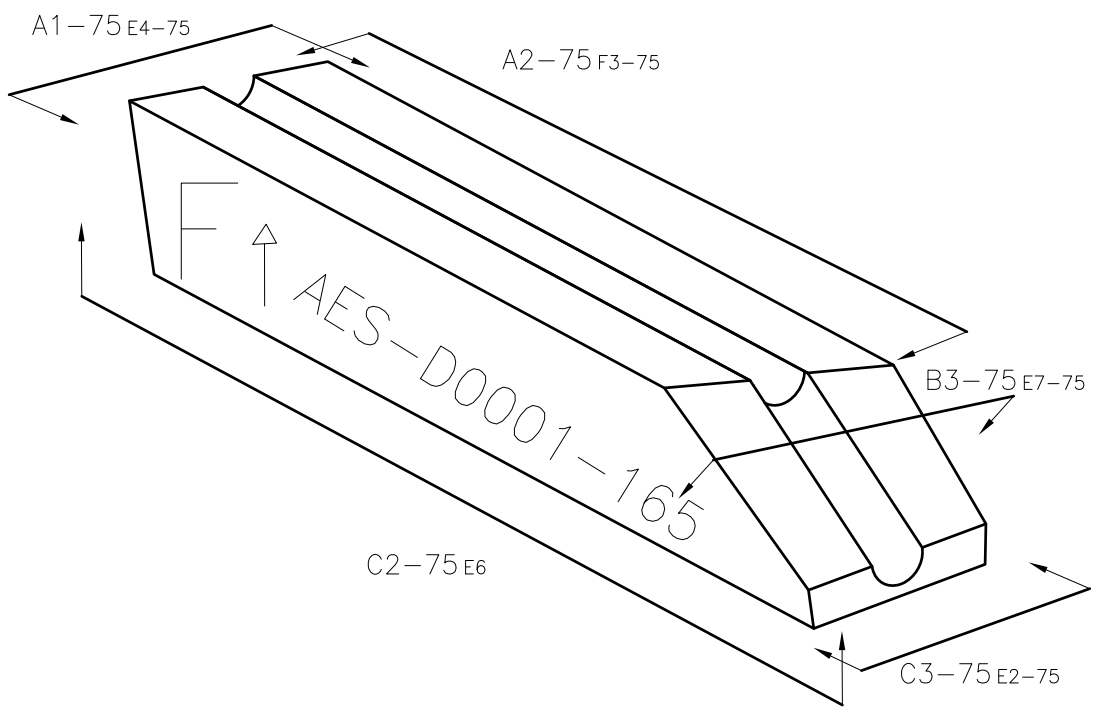

165

SECTION VIEW C8-75

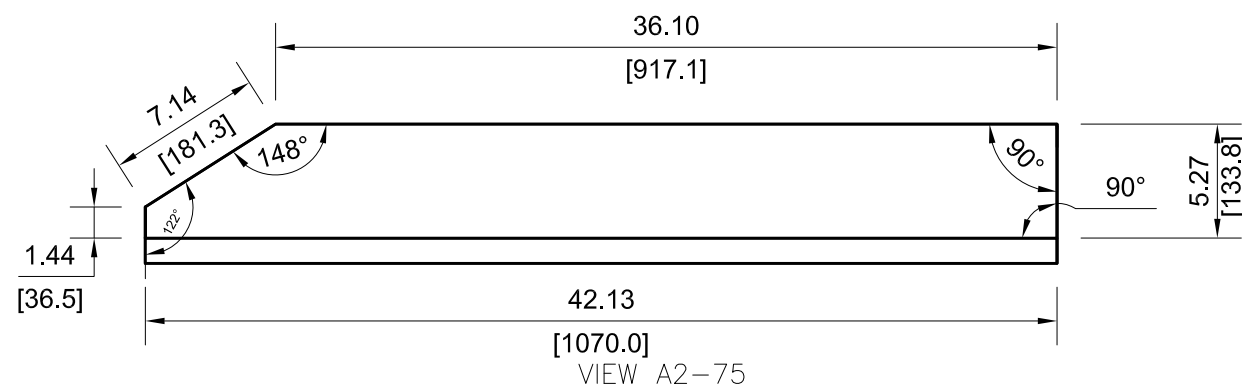
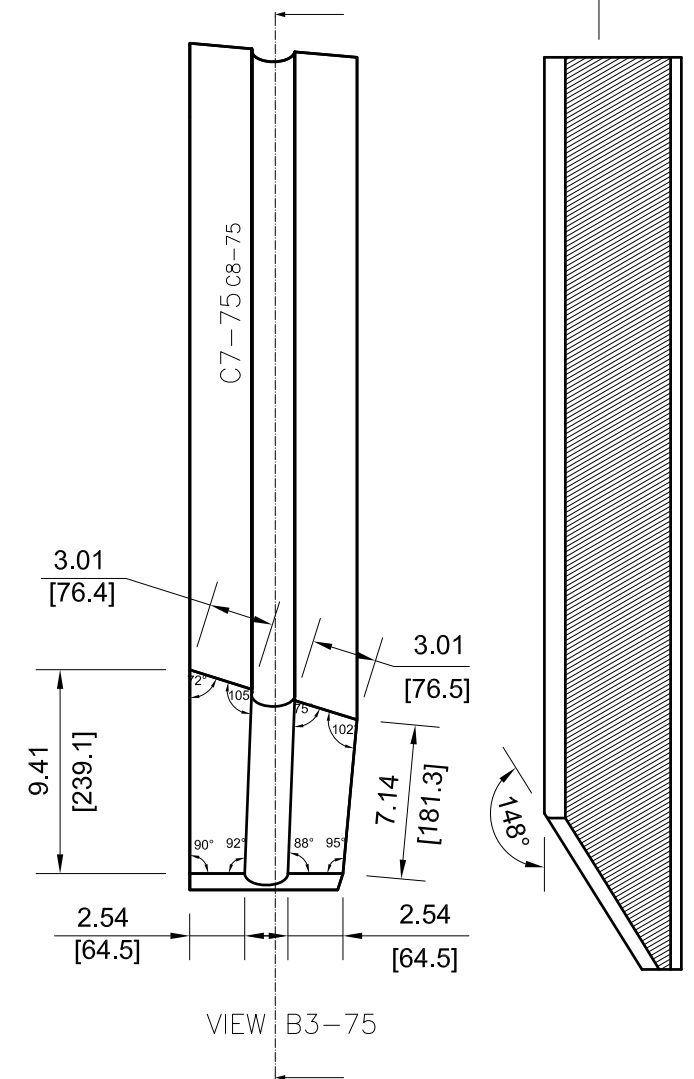
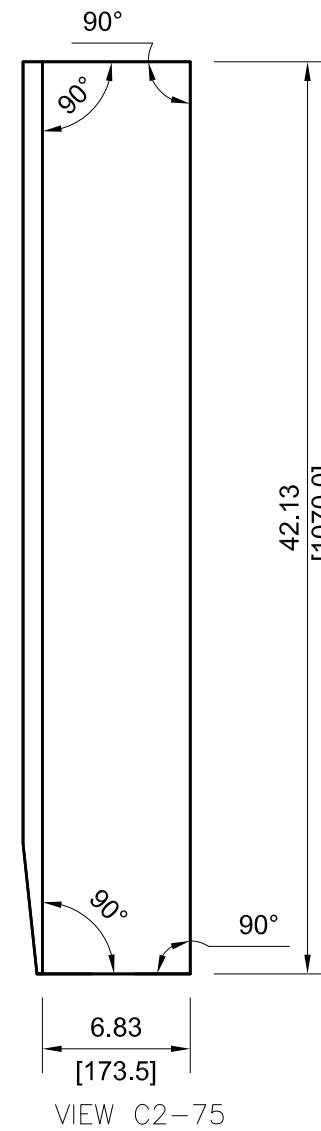
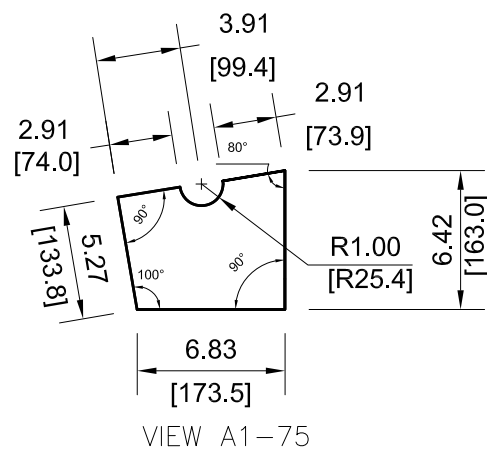
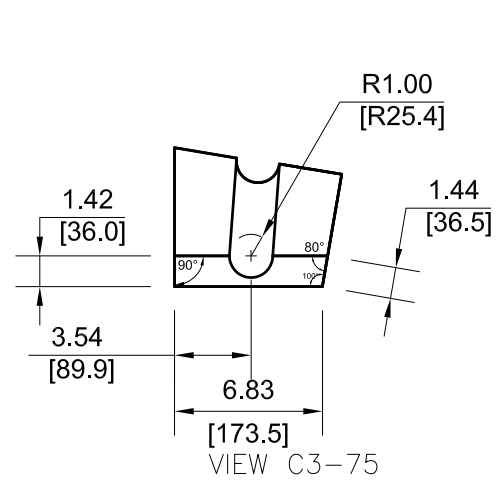

NOTE: ALL VIEWS TAKEN AS TRUE VIEWS PARALLEL TO SURFACE OF PART



DRAWING NUMBER					AES-D0001				
SIZE	SCALE	SHEET	OF	REVISION					
A3	NONE	75	124	E					

167

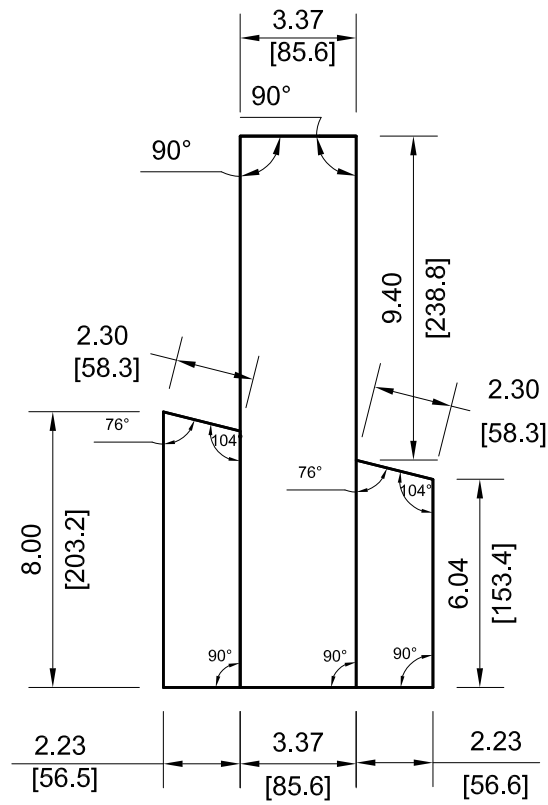

VIEW A7-76

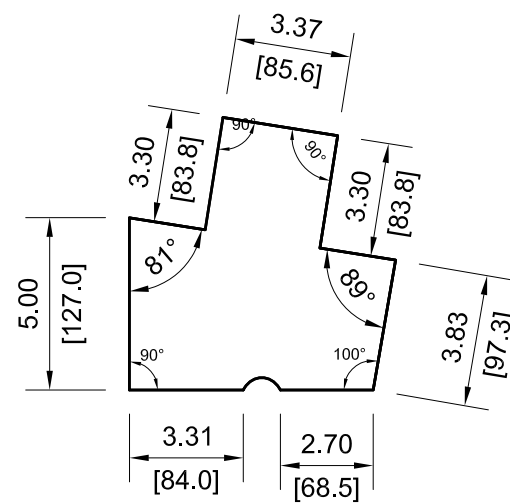

VIEW B8-76

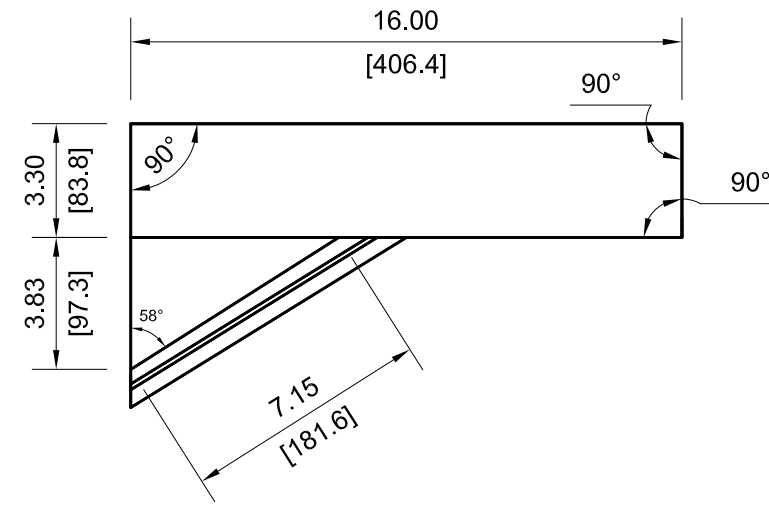

VIEW A8-76

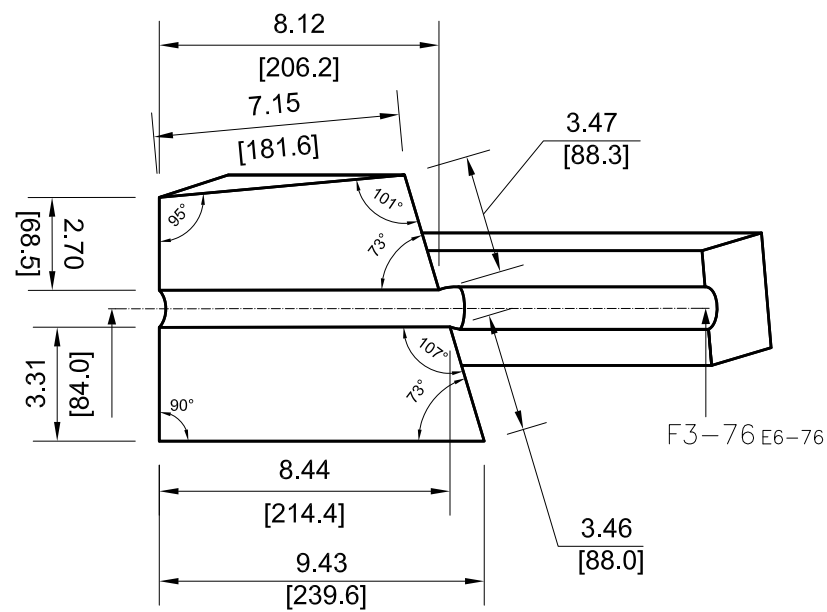
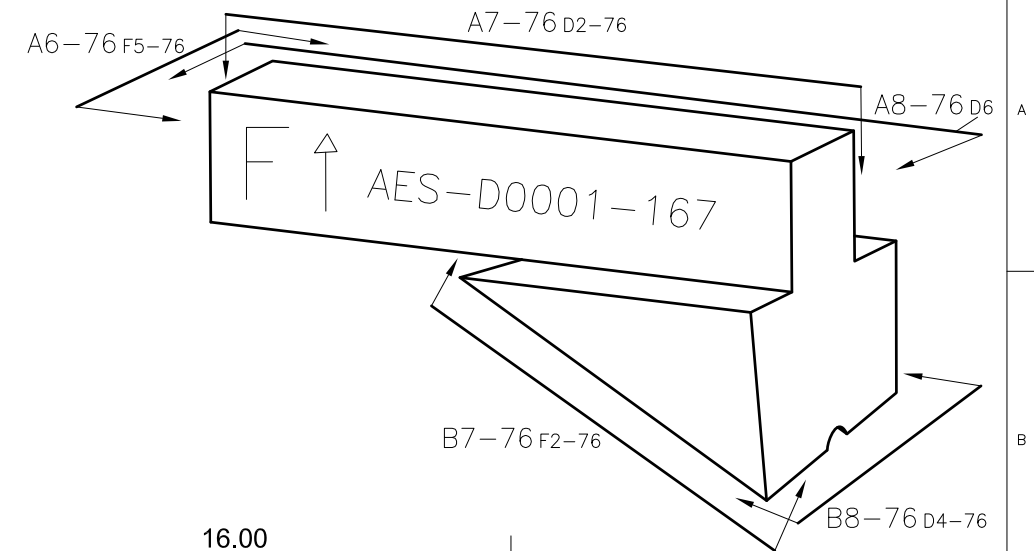

VIEW B7-76

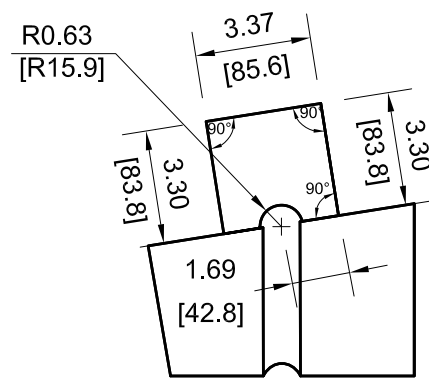

VIEW A6-76

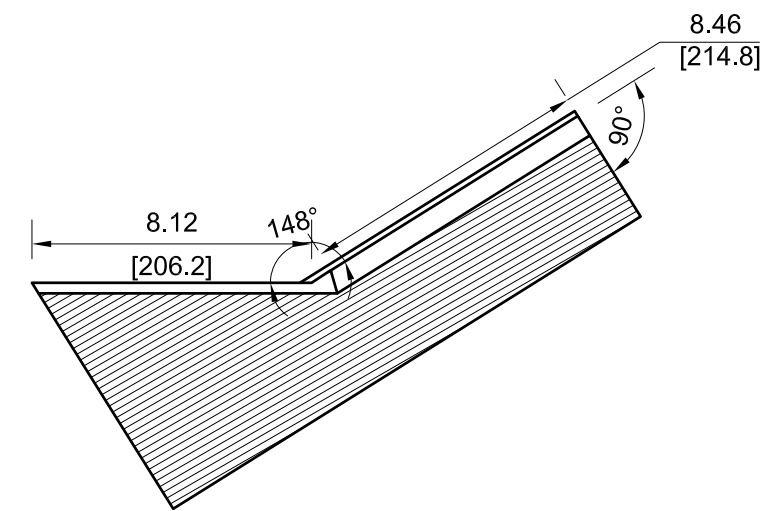

SECTION VIEW F3-76

NOTE: ALL VIEWS TAKEN AS TRUE VIEWS PARALLEL TO SURFACE OF PART

		DRAWING NUMBER			
		AES-D0001			
SIZE	SCALE	SHEET	OF	REVISION	
A3	NONE	76	124	E	

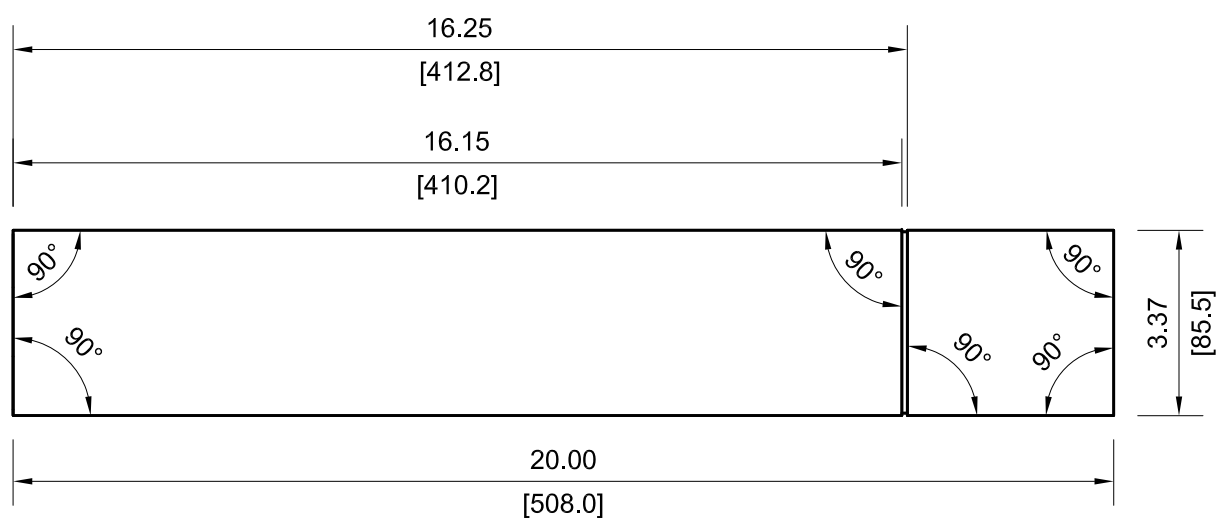
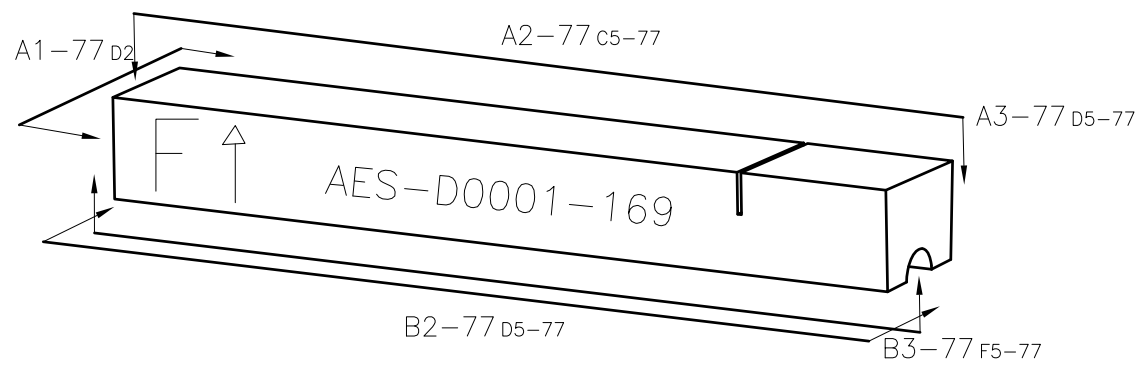

VIEW A2-77

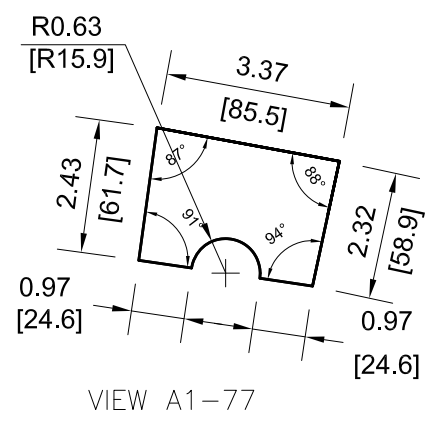

VIEW A1-77

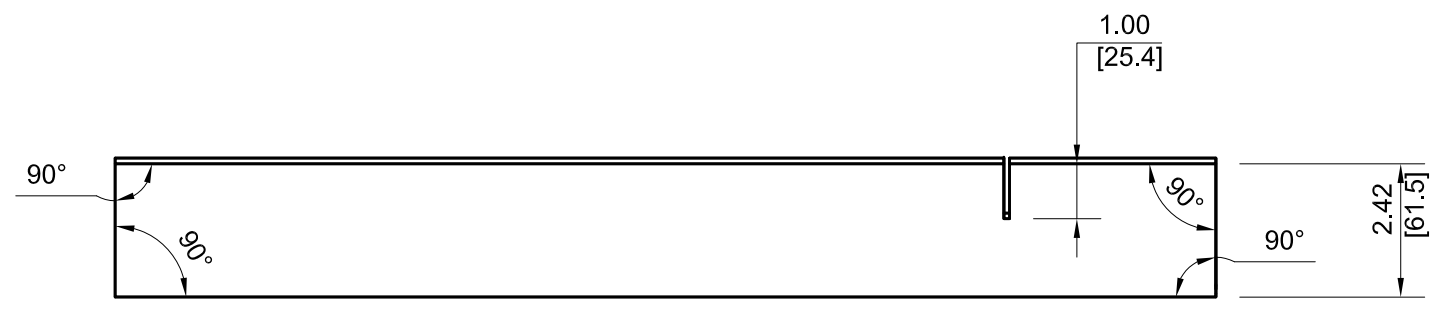

VIEW B2-77

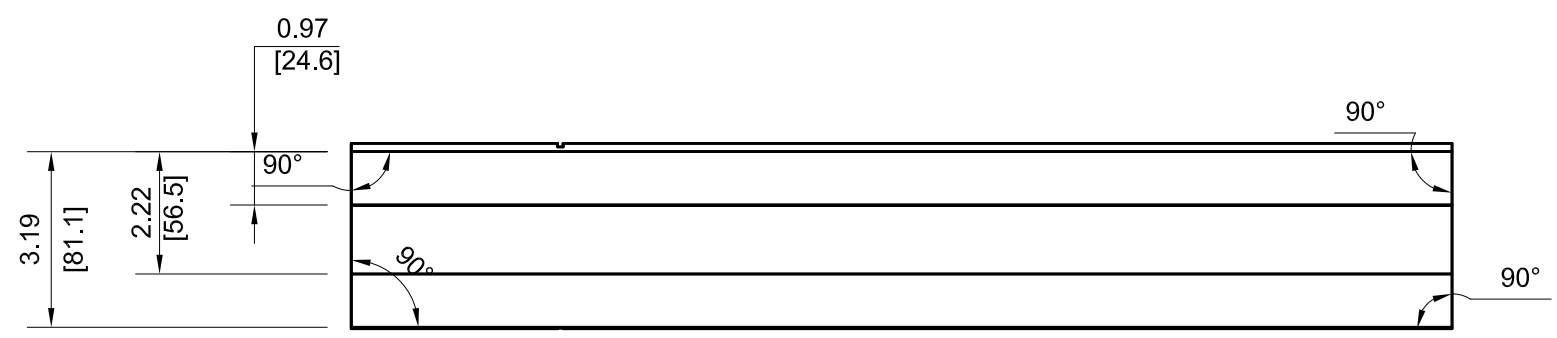

VIEW B3-77

1  
69

NOTE: ALL VIEWS TAKEN AS TRUE VIEWS PARALLEL TO SURFACE OF PART

		DRAWING NUMBER			
		AES-D0001			
SIZE	SCALE	SHEET	OF	REVISION	
A3	NONE	77	124	E	

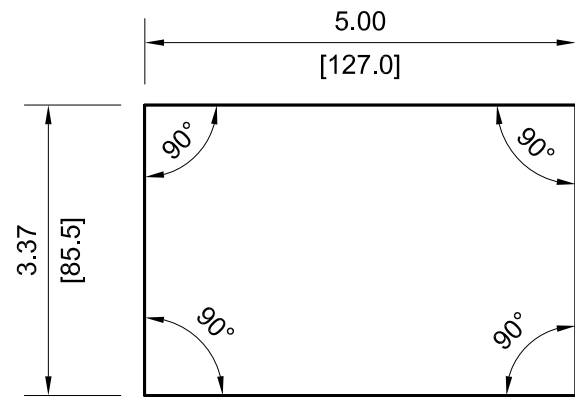

VIEW C7-78

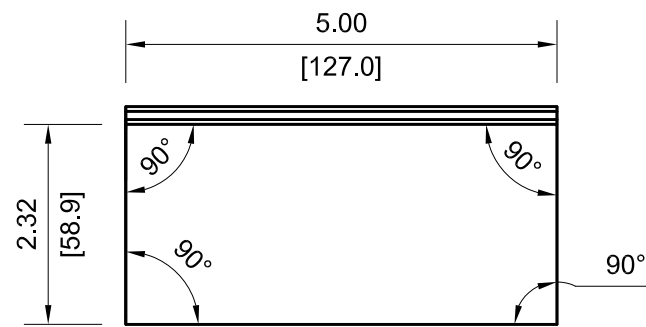

VIEW E6-78

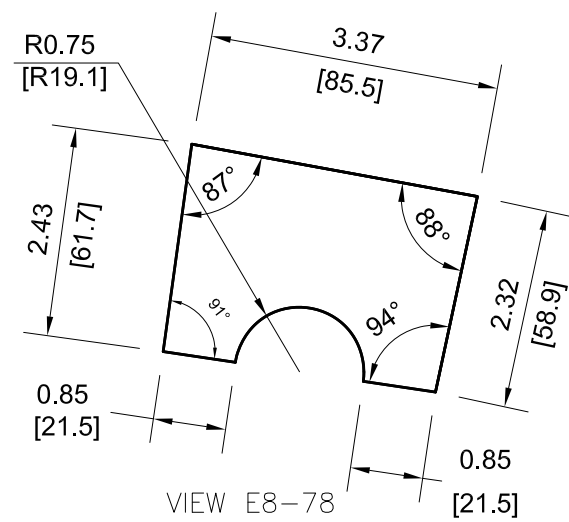

VIEW E8-78

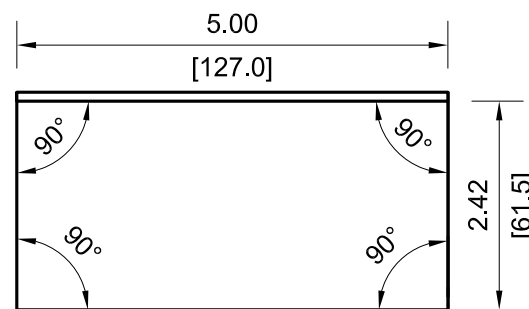

VIEW C6-78

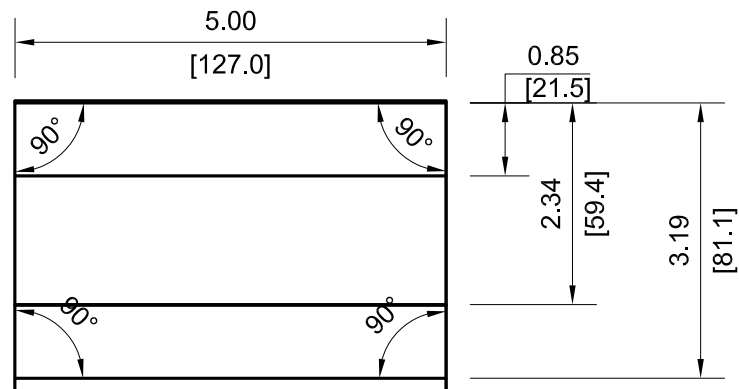

VIEW E7-78

171

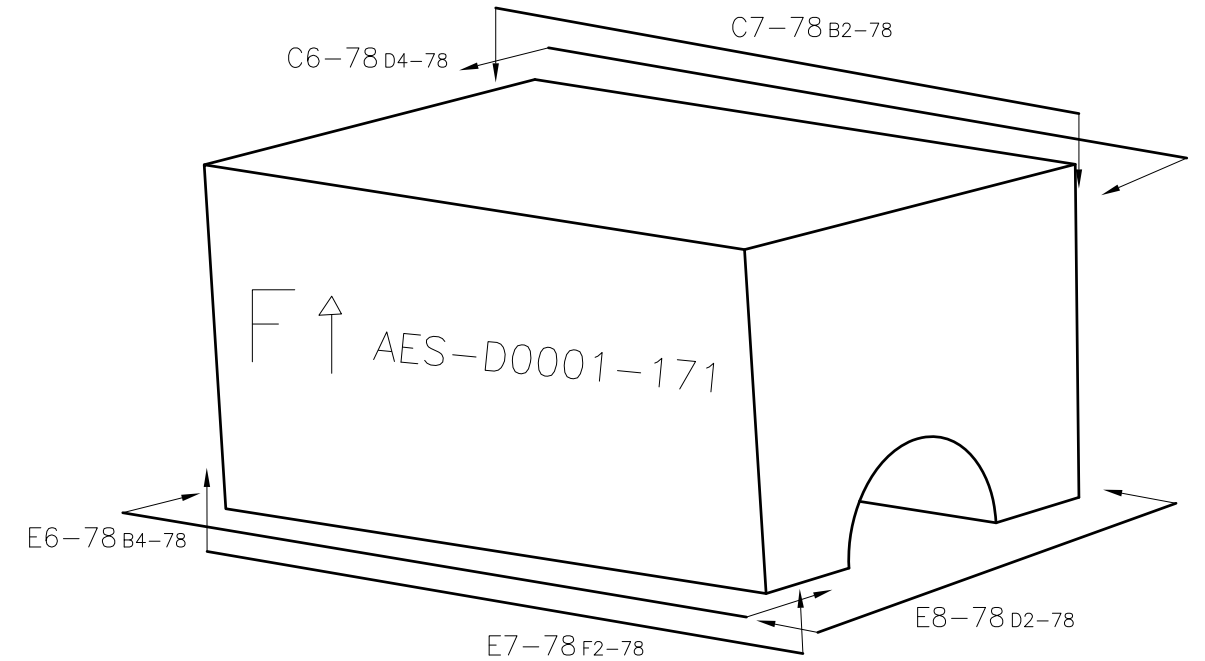

NOTE: ALL VIEWS TAKEN AS TRUE VIEWS PARALLEL TO SURFACE OF PART



DRAWING NUMBER					AES-D0001	
SIZE	SCALE	SHEET	OF	REVISION		
A3	NONE	78	124	E		

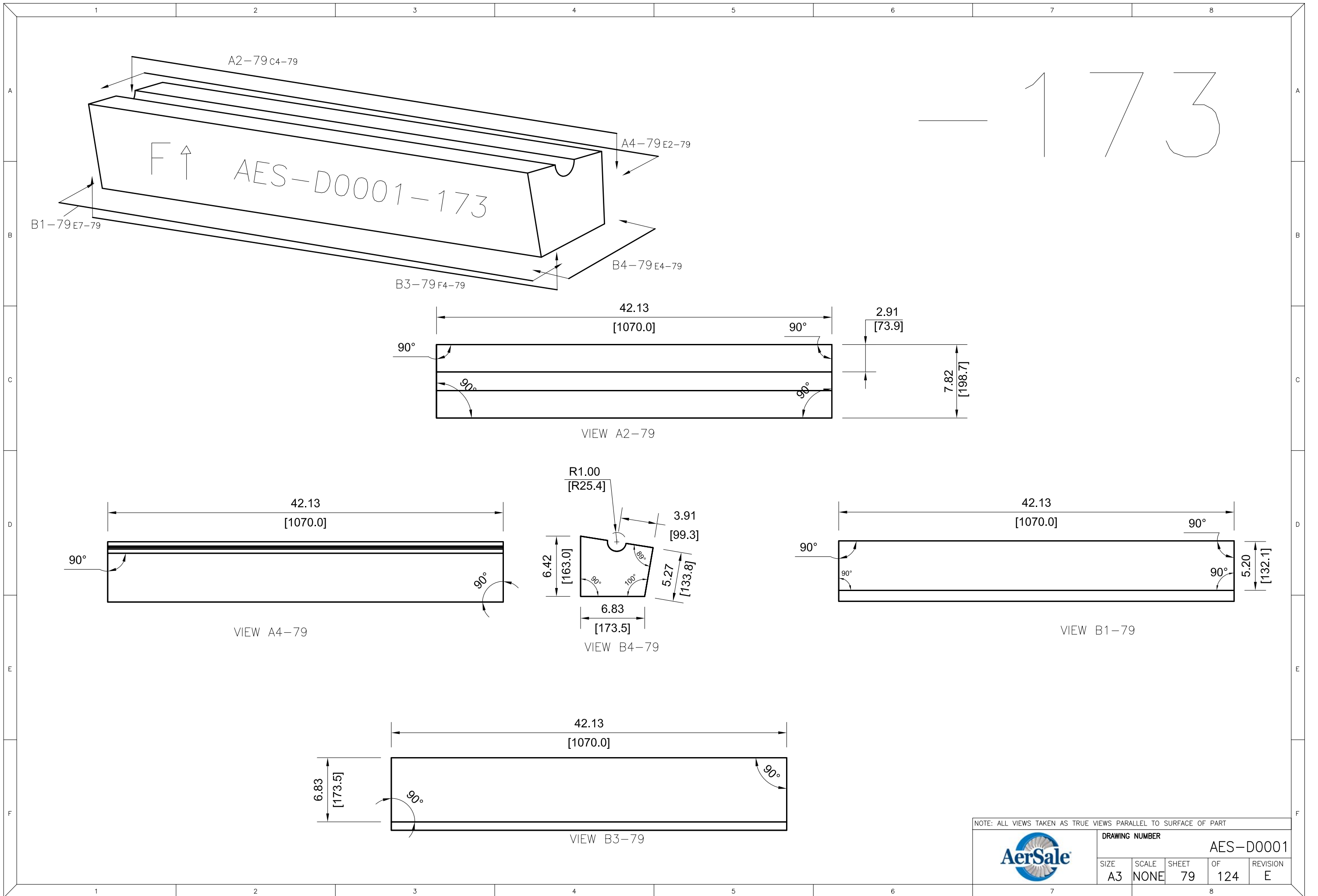

1 2 3 4 5 6 7 8

A  
B  
C  
D  
E  
F

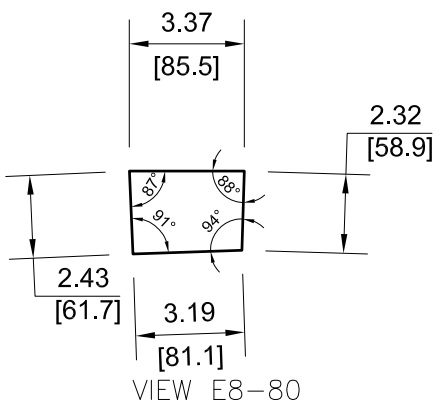
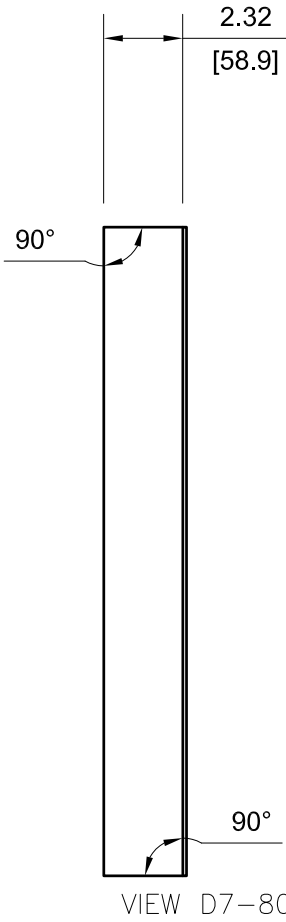
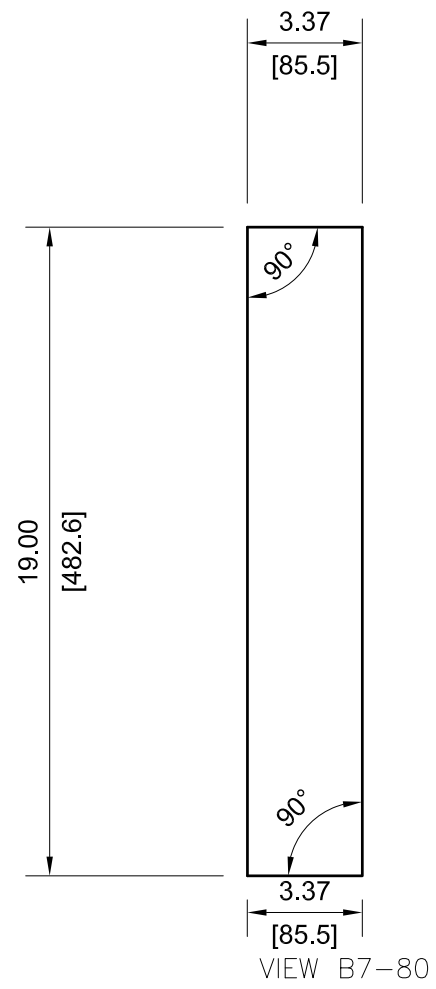

— 175

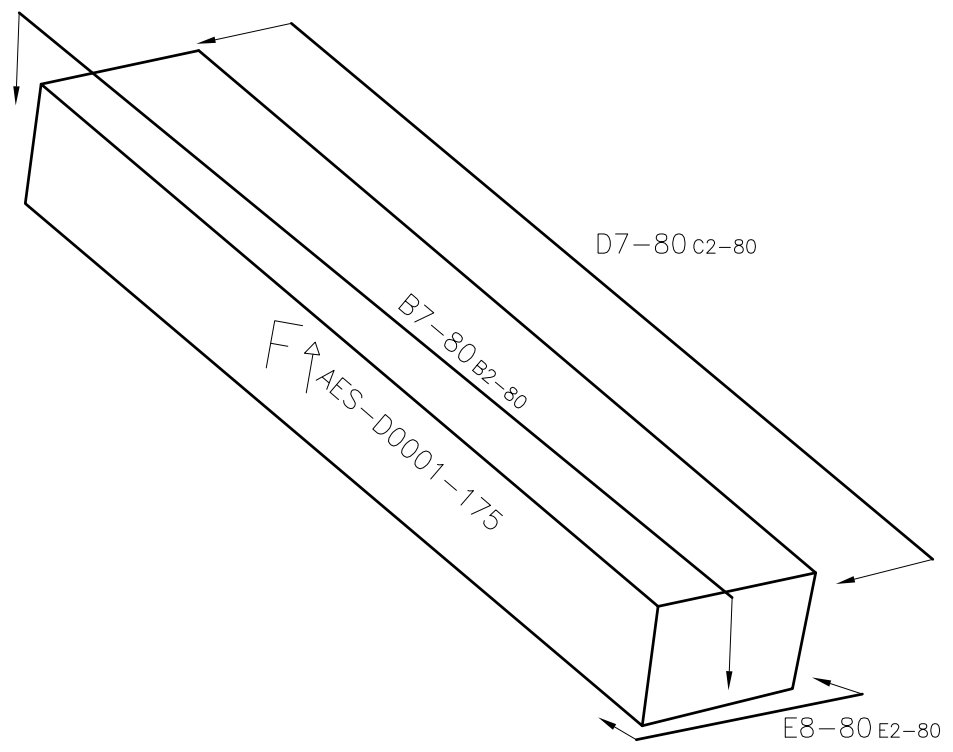

NOTE: ALL VIEWS TAKEN AS TRUE VIEWS PARALLEL TO SURFACE OF PART

	DRAWING NUMBER				
	AES-D0001				
SIZE	SCALE	SHEET	OF	REVISION	
A3	NONE	80	124	E	

1 2 3 4 5 6 7 8

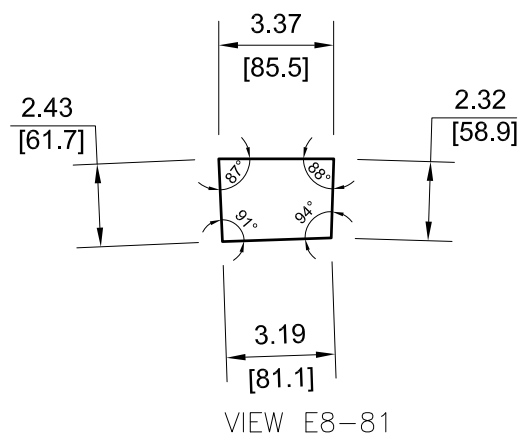
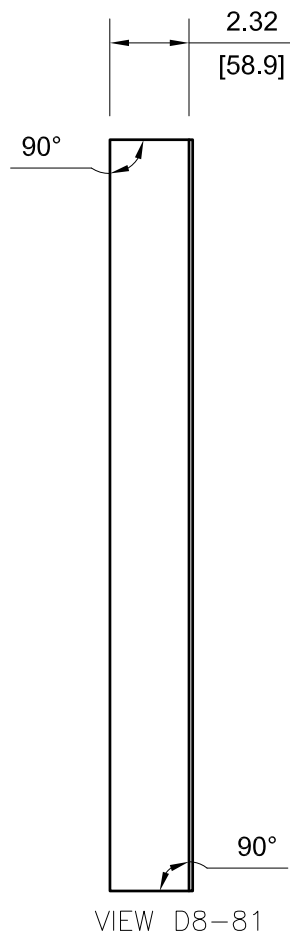
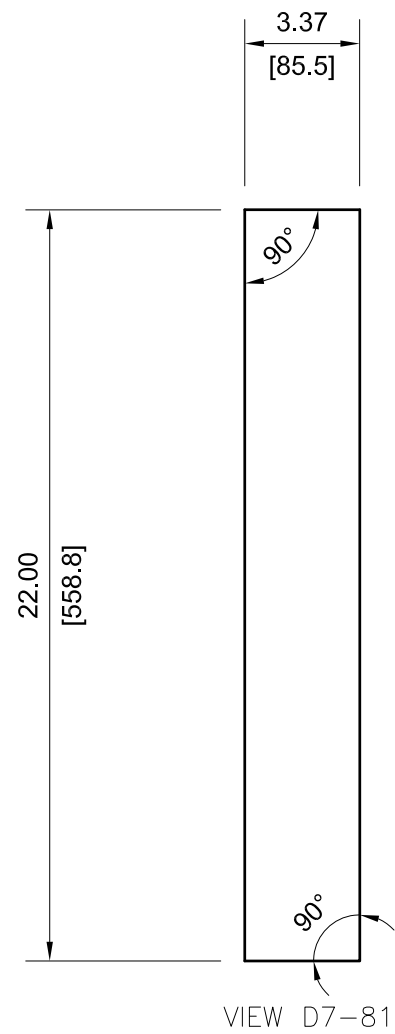

— 177

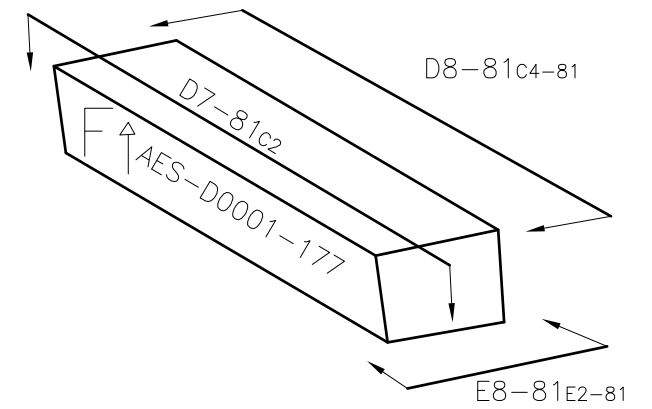

NOTE: ALL VIEWS TAKEN AS TRUE VIEWS PARALLEL TO SURFACE OF PART



DRAWING NUMBER					AES-D0001				
SIZE	SCALE	SHEET	OF	REVISION					
A3	NONE	81	124	E					

179

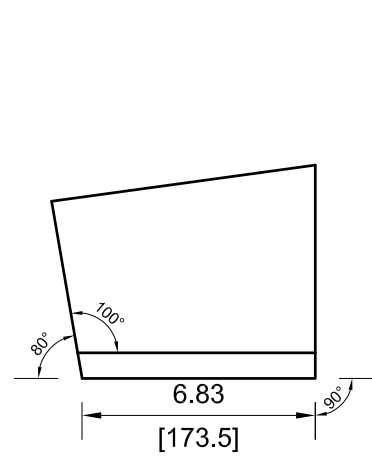

VIEW D6-82

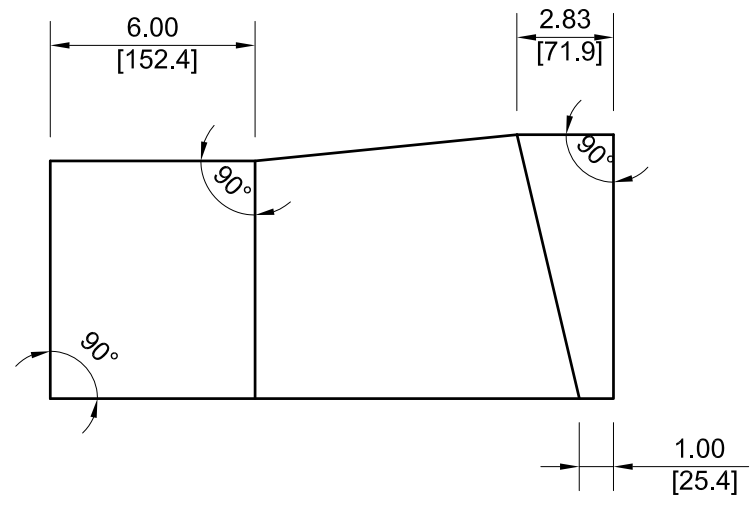

VIEW D7-82

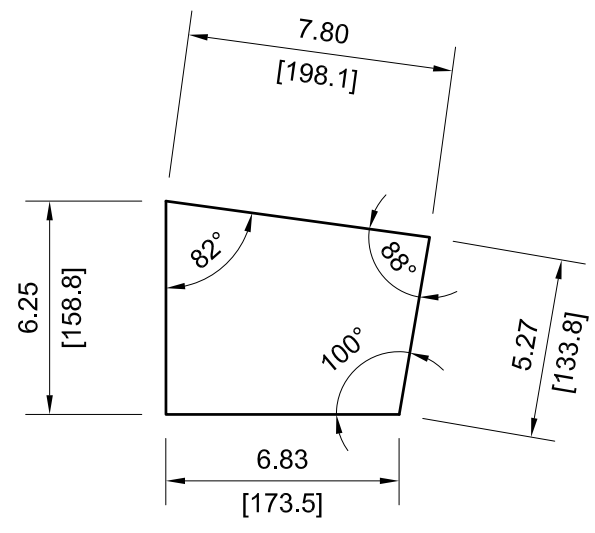

VIEW E8-82

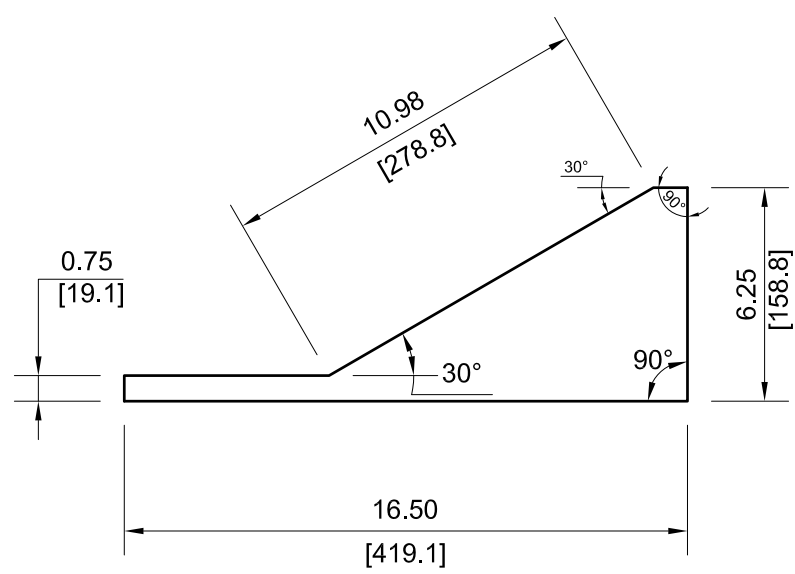

VIEW E6-82

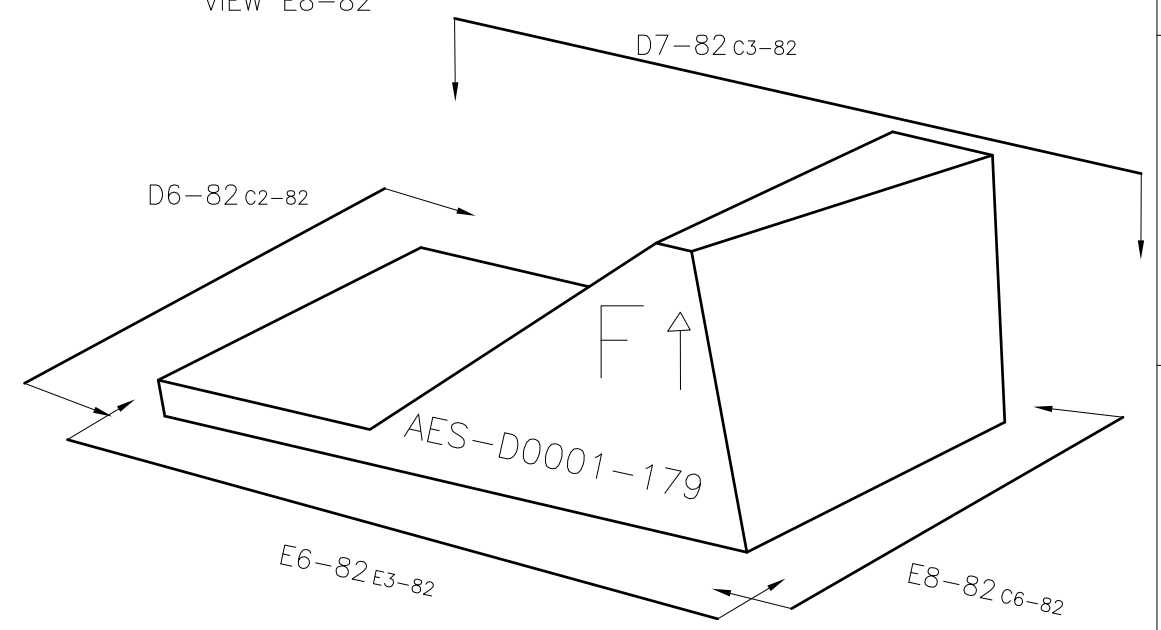

NOTE: ALL VIEWS TAKEN AS TRUE VIEWS PARALLEL TO SURFACE OF PART

		DRAWING NUMBER			
		AES-D0001			
SIZE	SCALE	SHEET	OF	REVISION	
A3	NONE	82	124	E	

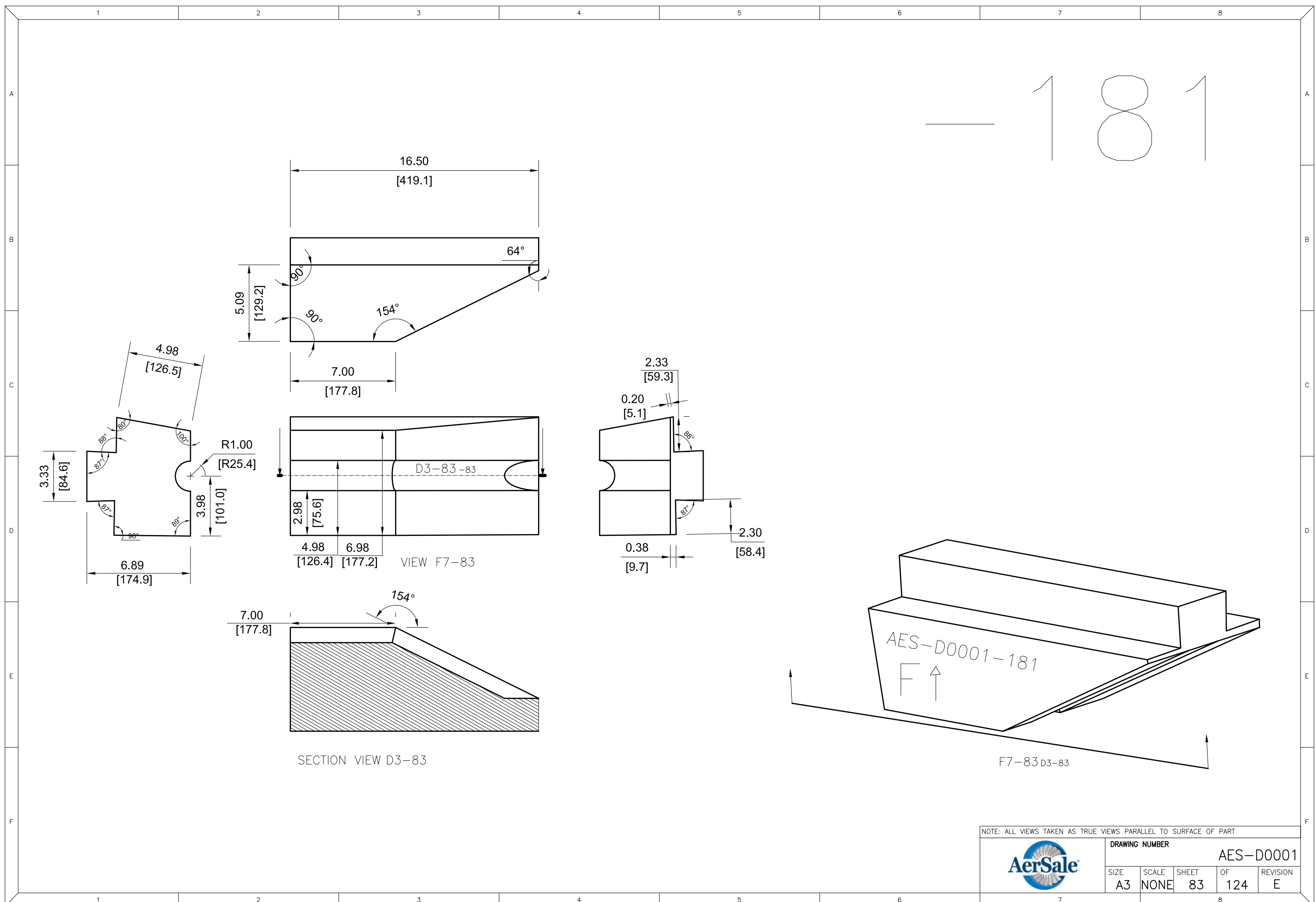

181

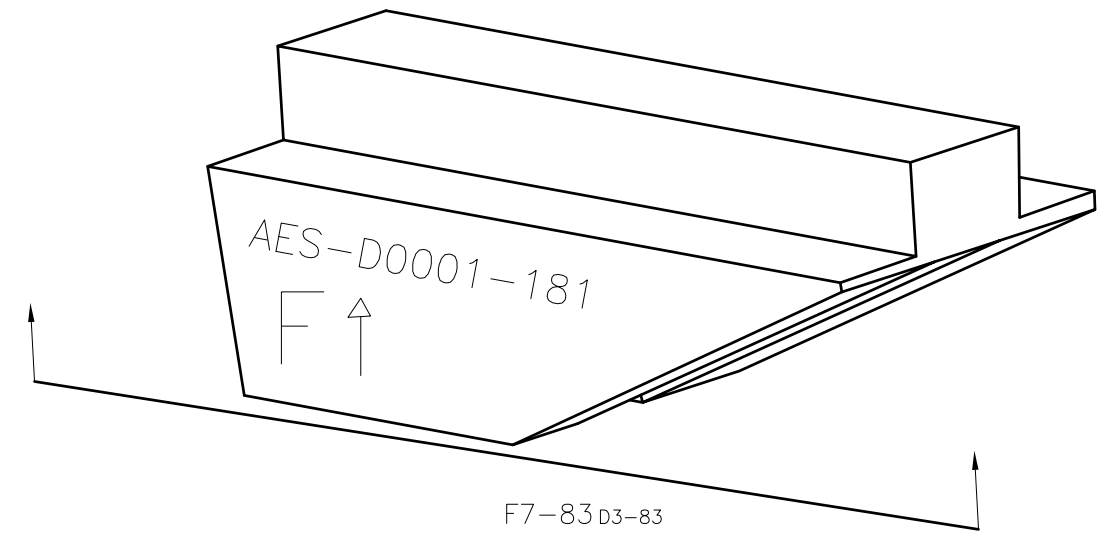

F7-83 D3-83

NOTE: ALL VIEWS TAKEN AS TRUE VIEWS PARALLEL TO SURFACE OF PART

		DRAWING NUMBER			
		AES-D0001			
SIZE	SCALE	SHEET	OF	REVISION	
A3	NONE	83	124	E	

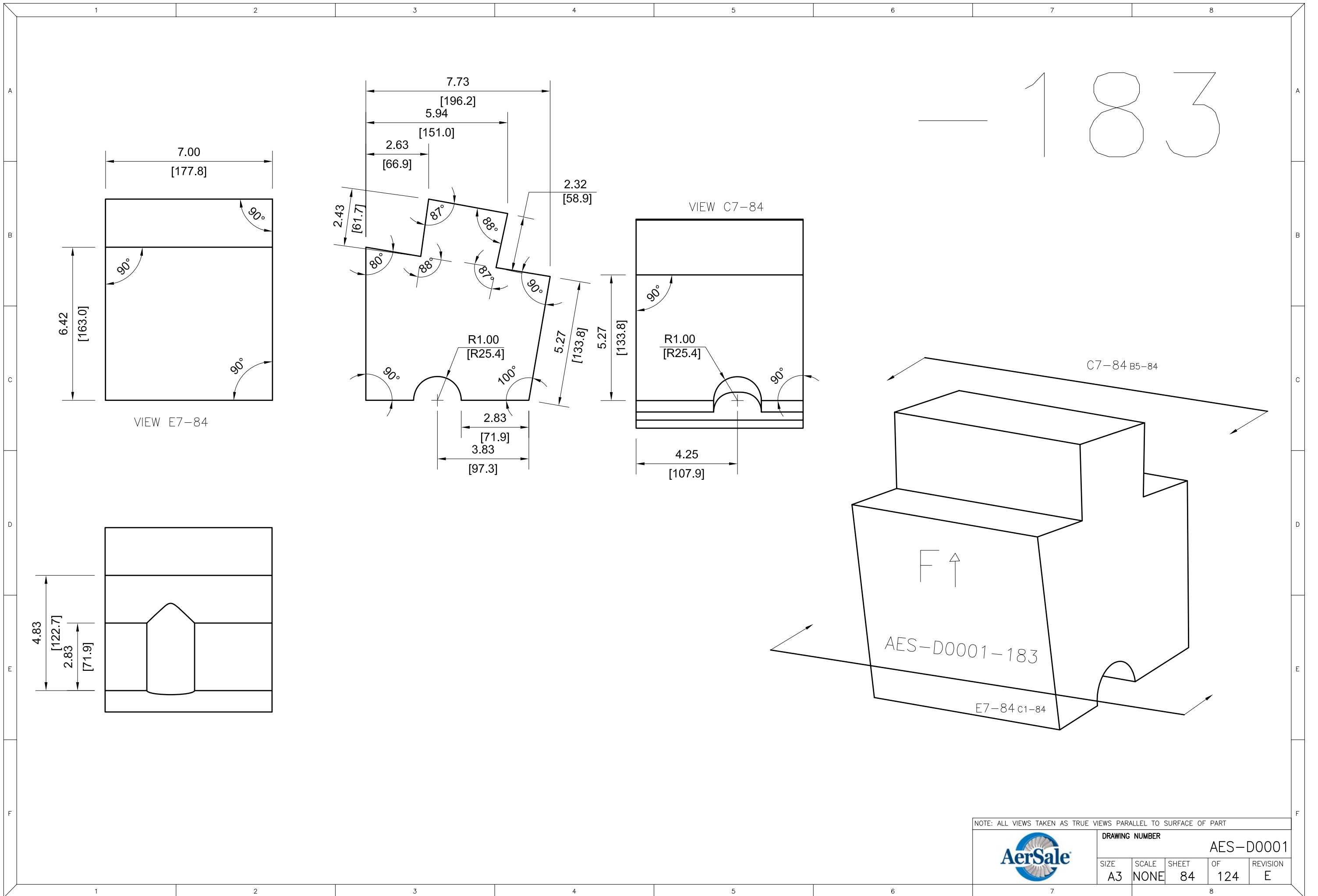

183

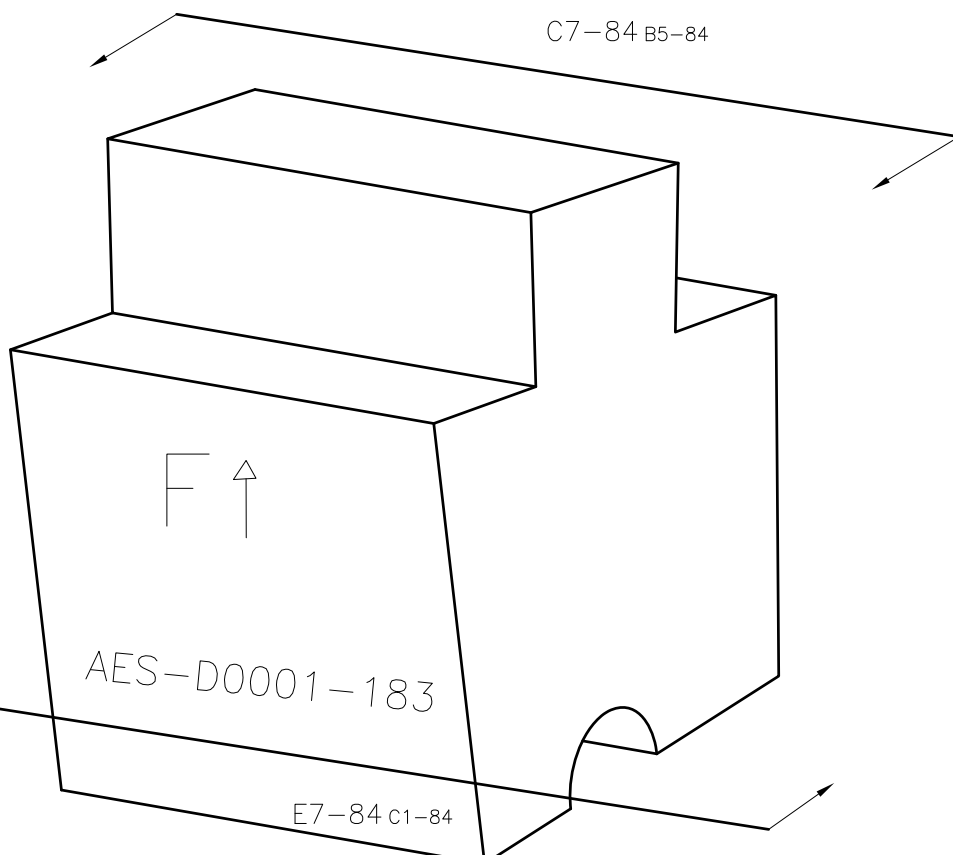

NOTE: ALL VIEWS TAKEN AS TRUE VIEWS PARALLEL TO SURFACE OF PART

		DRAWING NUMBER			
		AES-D0001			
SIZE	SCALE	SHEET	OF	REVISION	
A3	NONE	84	124	E	

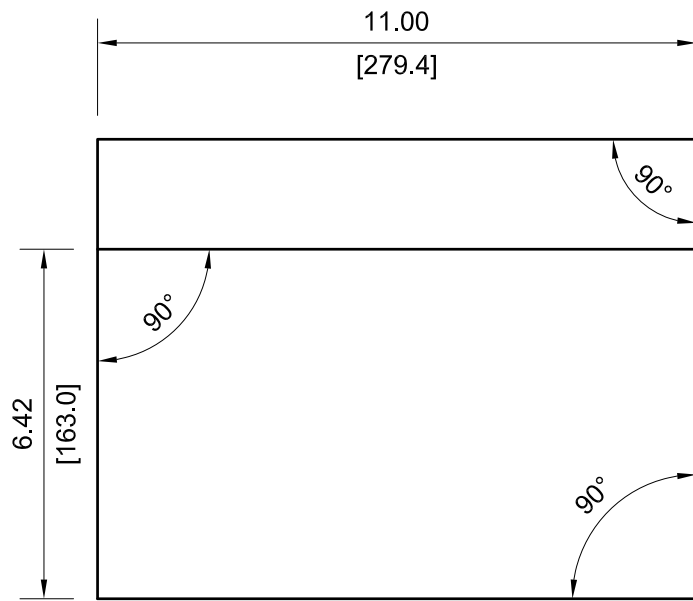

VIEW D6-85

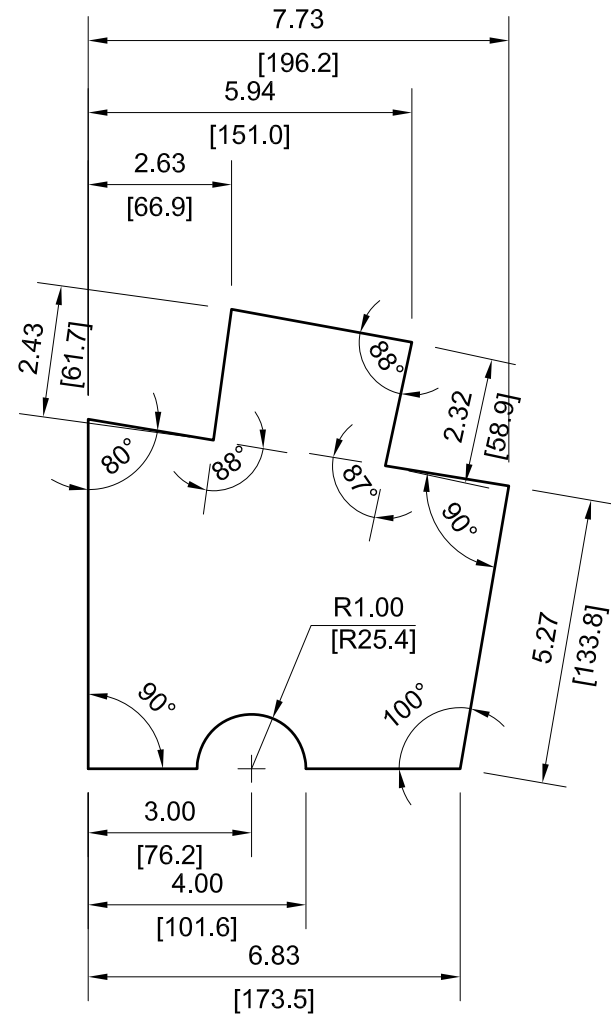

185

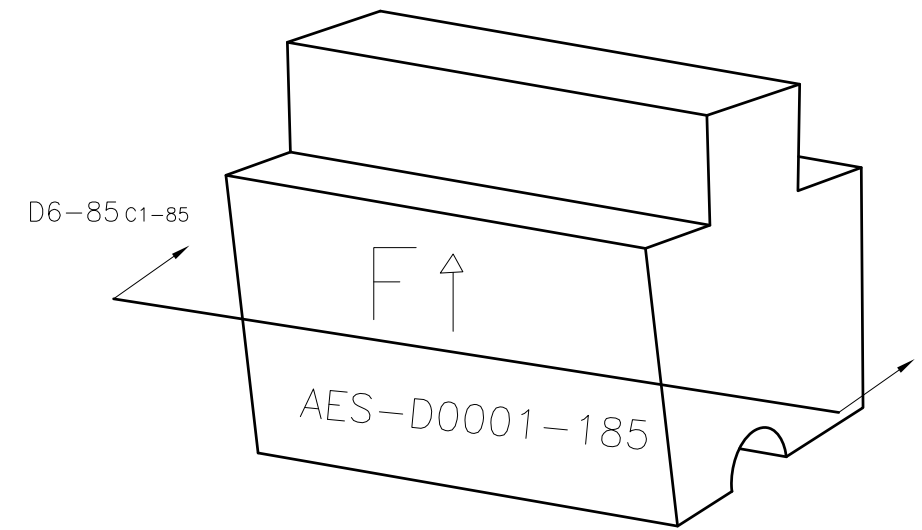
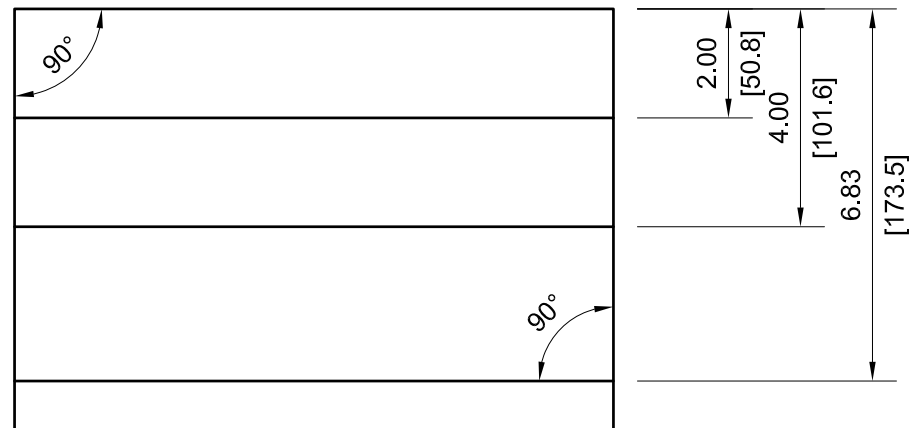

NOTE: ALL VIEWS TAKEN AS TRUE VIEWS PARALLEL TO SURFACE OF PART

	DRAWING NUMBER				
	AES-D0001				
SIZE	SCALE	SHEET	OF	REVISION	
A3	NONE	85	124	E	

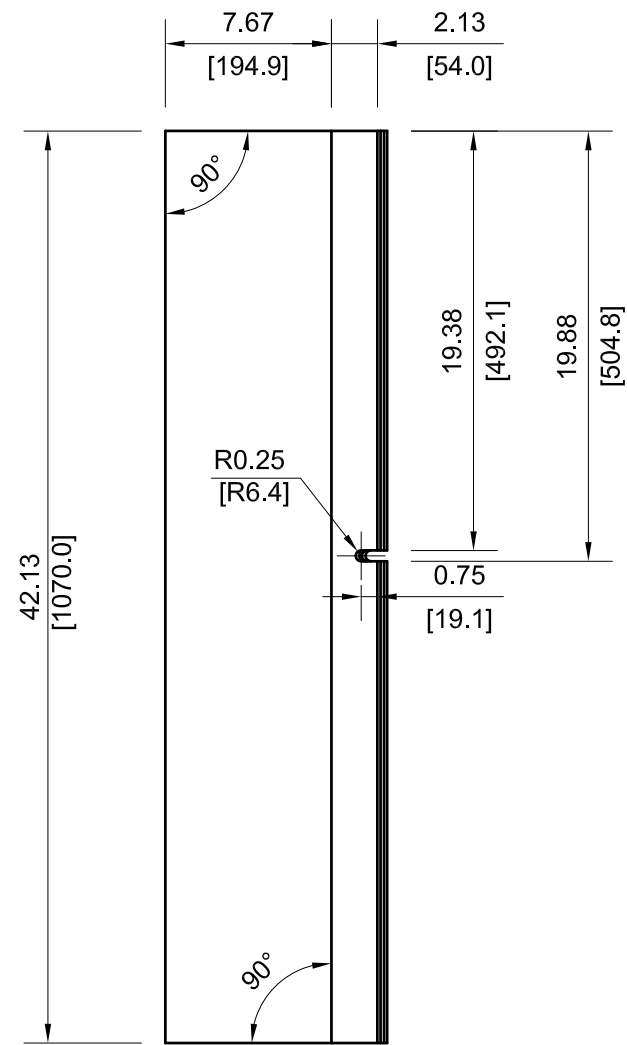

VIEW D6-86

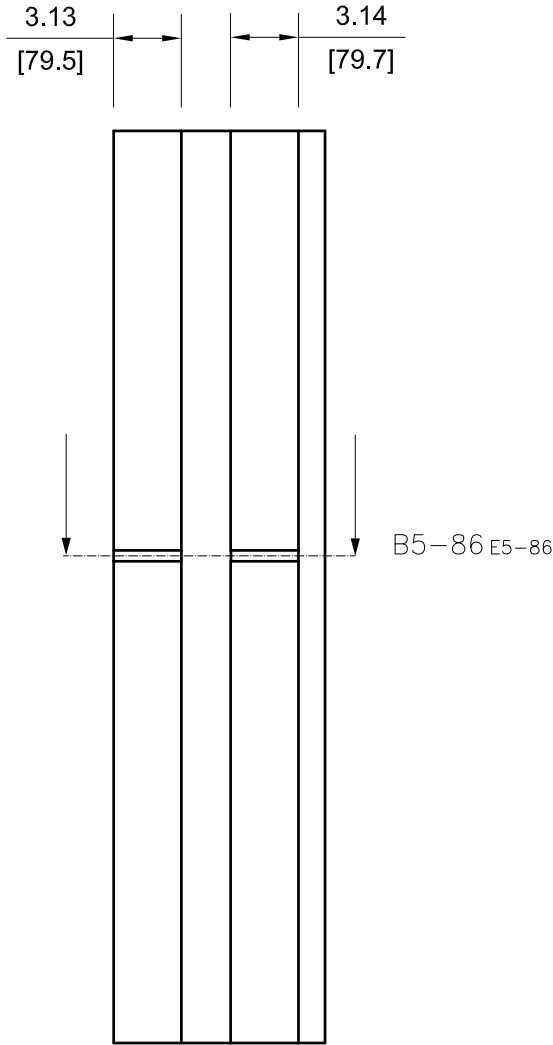

VIEW D8-86

187

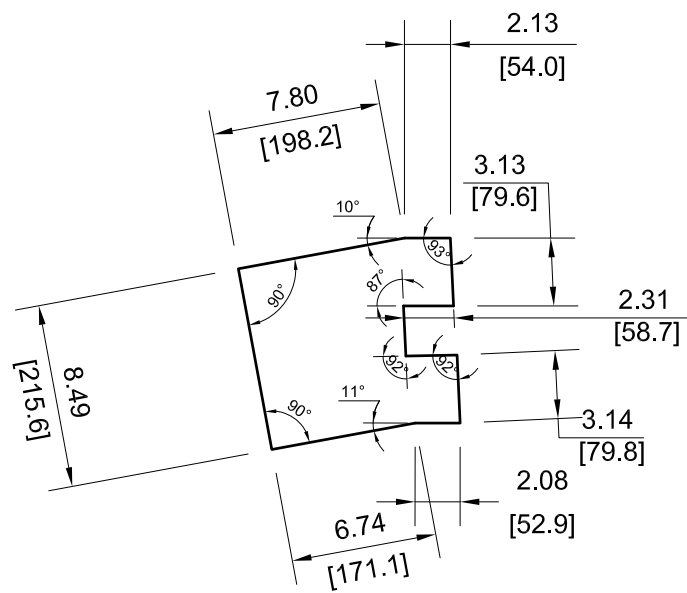

VIEW E8-86

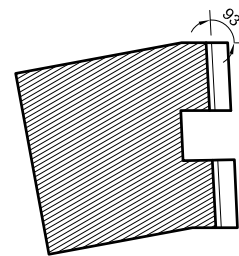

SECTION VIEW B5-86

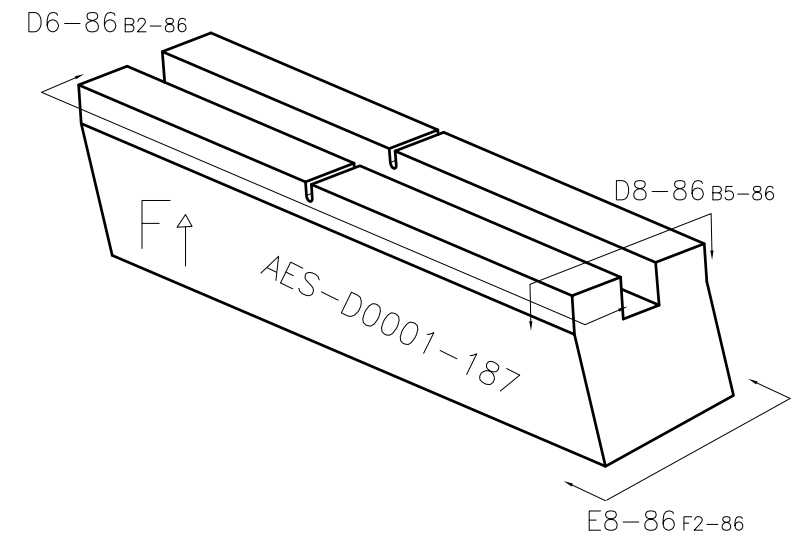

NOTE: ALL VIEWS TAKEN AS TRUE VIEWS PARALLEL TO SURFACE OF PART

		DRAWING NUMBER			
		AES-D0001			
SIZE	SCALE	SHEET	OF	REVISION	
A3	NONE	86	124	E	

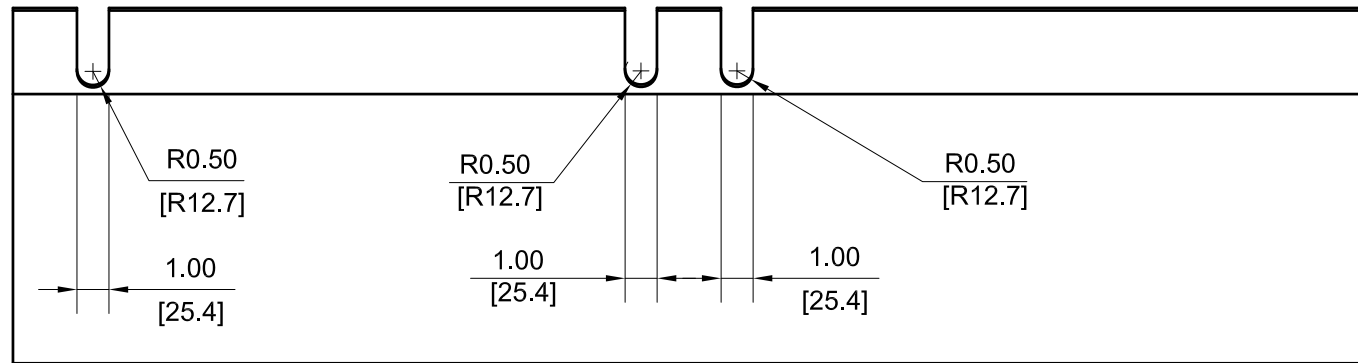

VIEW B6-87

B6-87 A2-87

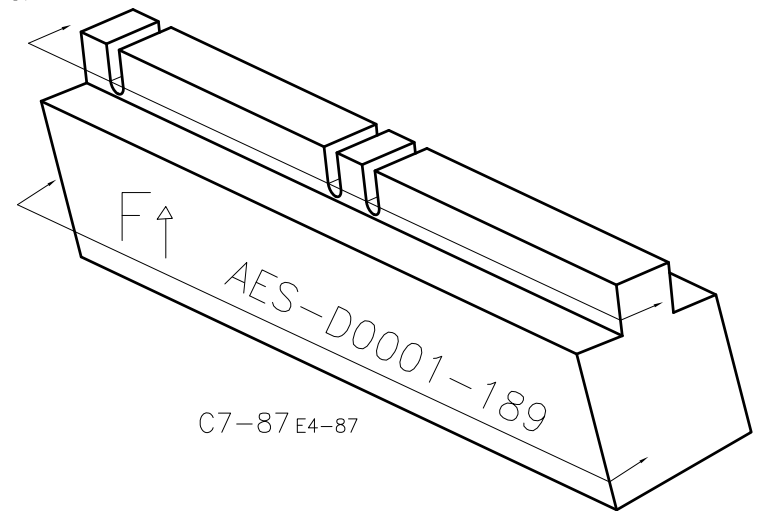

C7-87 E4-87

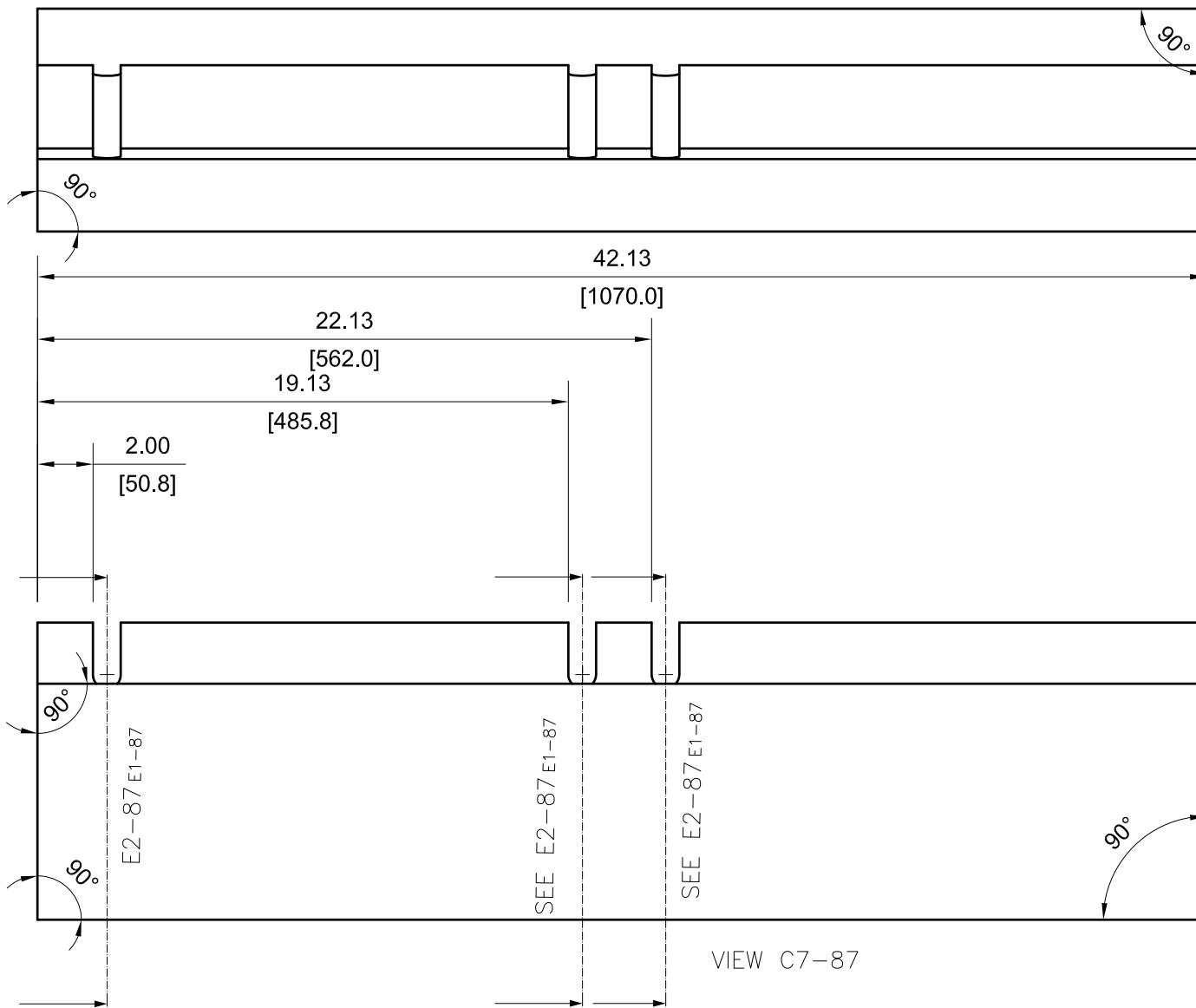

VIEW C7-87

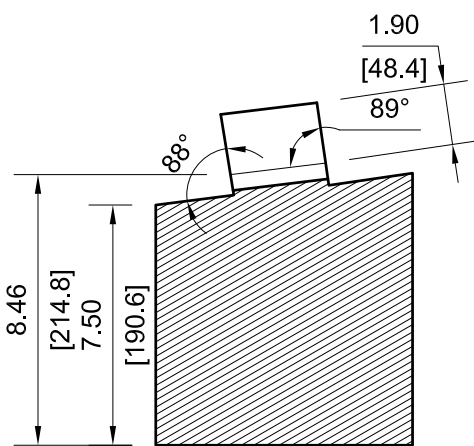

SECTION VIEW E2-87

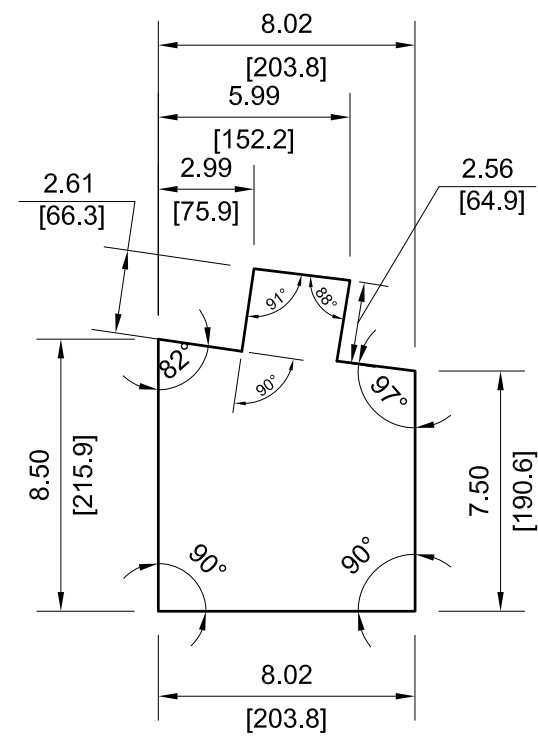

NOTE: ALL VIEWS TAKEN AS TRUE VIEWS PARALLEL TO SURFACE OF PART



DRAWING NUMBER					AES-D0001	
SIZE	SCALE	SHEET	OF	REVISION		
A3	NONE	87	124	E		

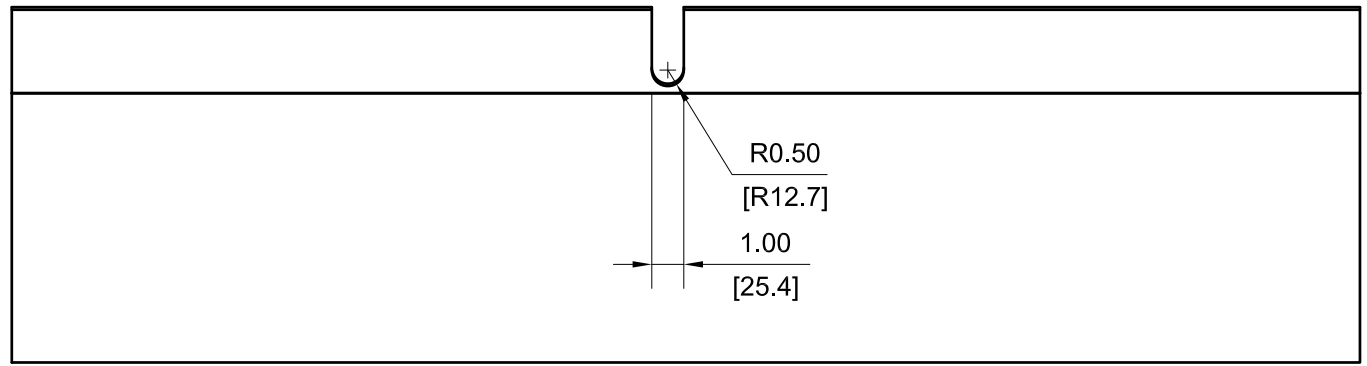

VIEW B6-88

B6-88 A2-88

191

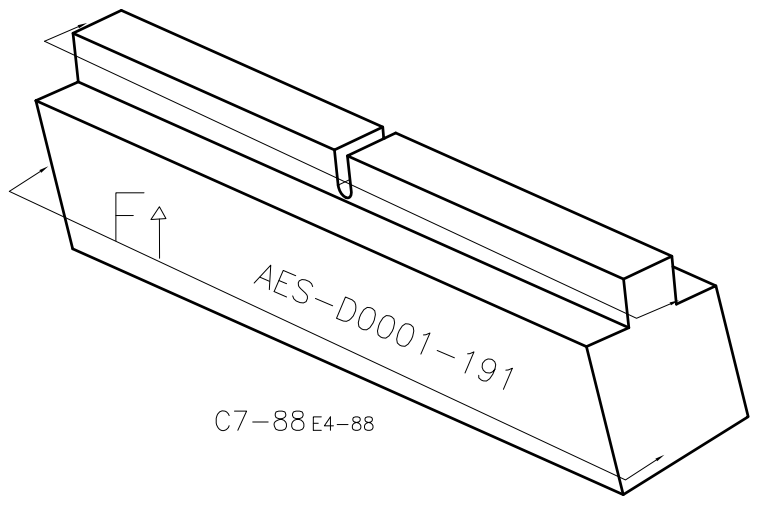

C7-88 E4-88

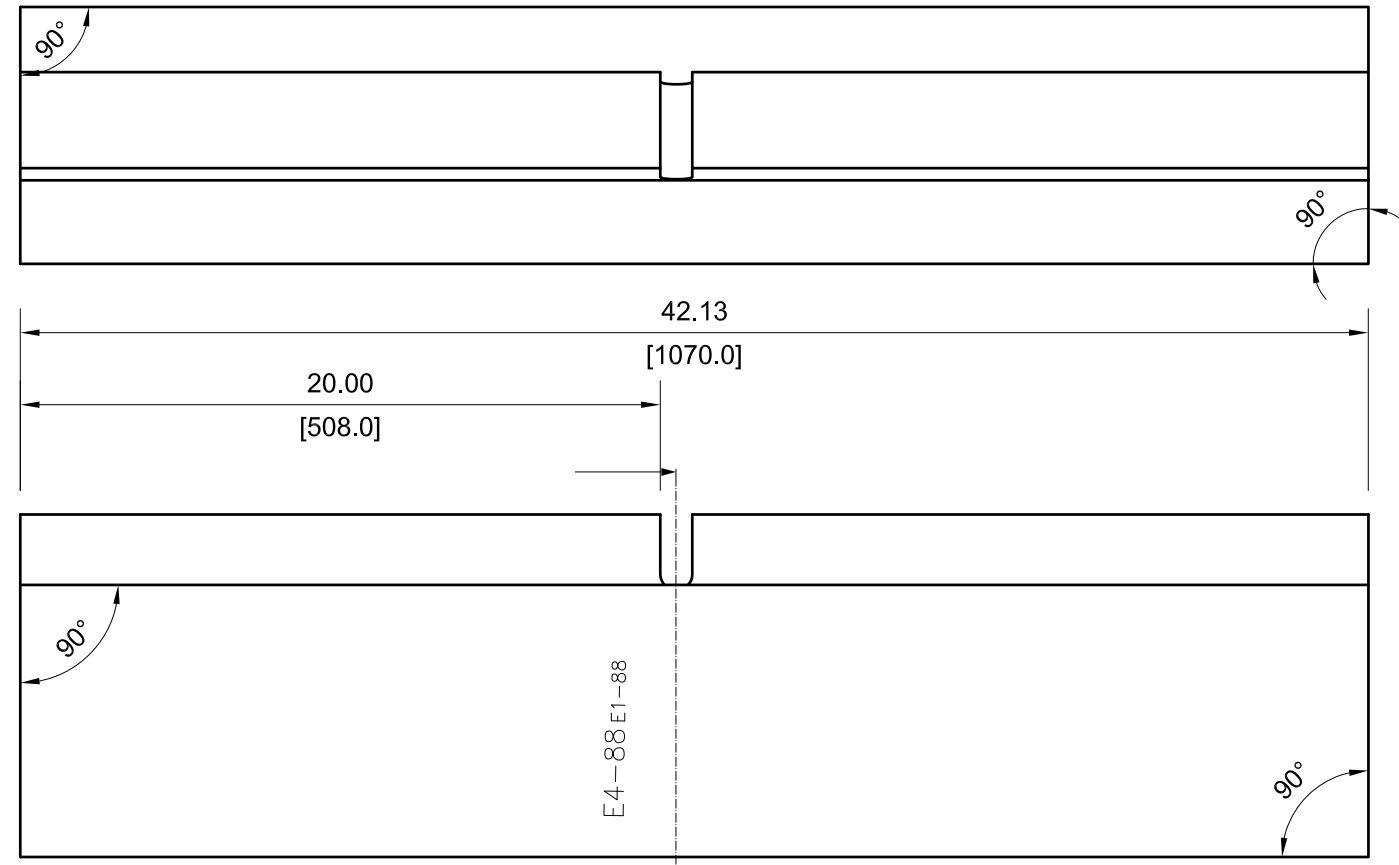

VIEW C7-88

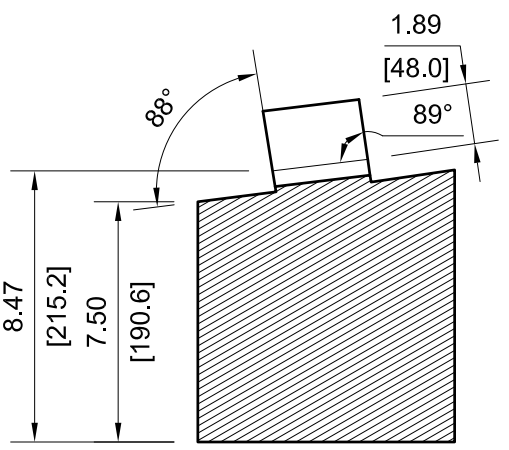

SECTION VIEW E4-88

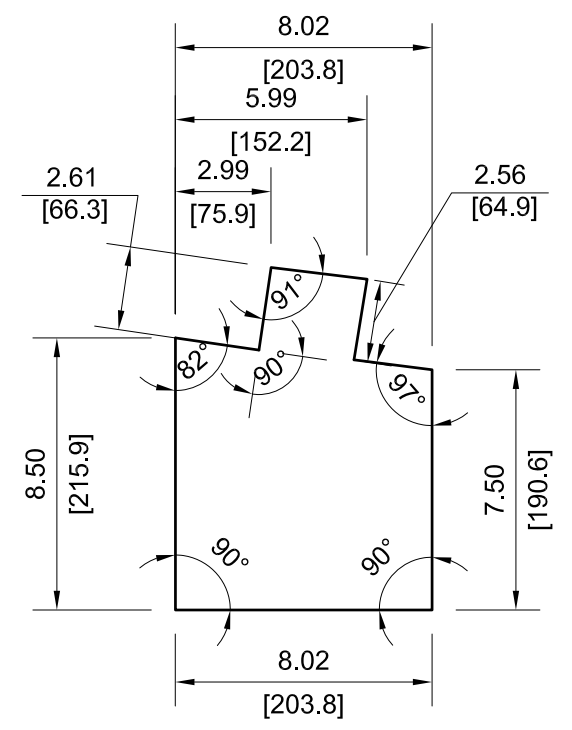

NOTE: ALL VIEWS TAKEN AS TRUE VIEWS PARALLEL TO SURFACE OF PART



DRAWING NUMBER					AES-D0001	
SIZE	SCALE	SHEET	OF	REVISION		
A3	NONE	88	124	E		

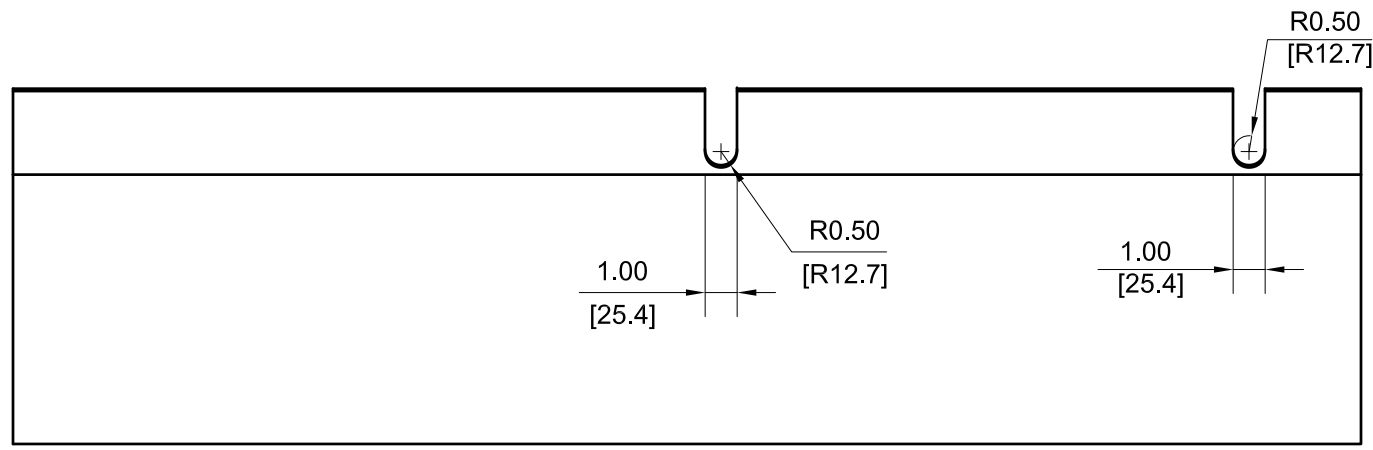

VIEW B6-89

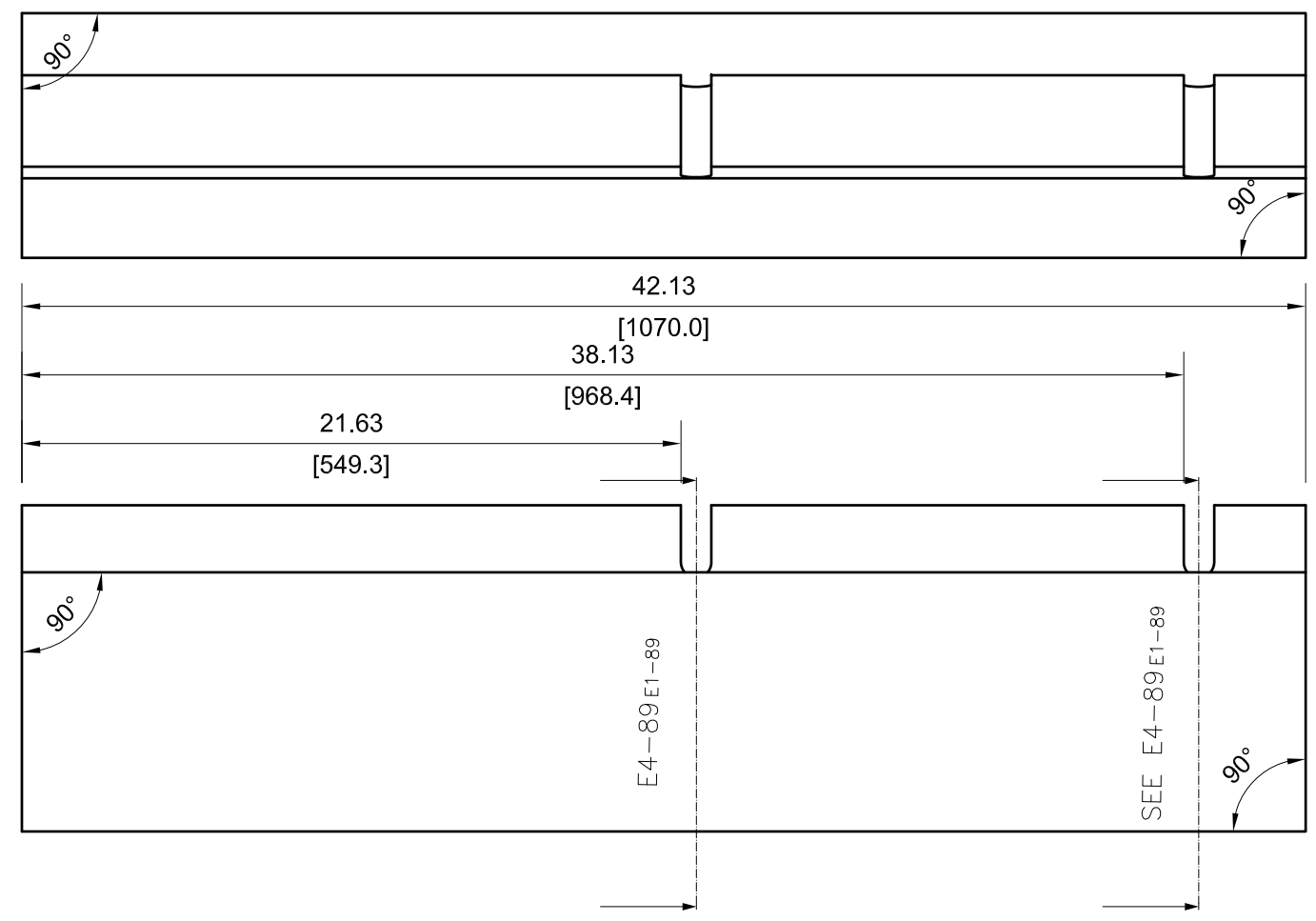
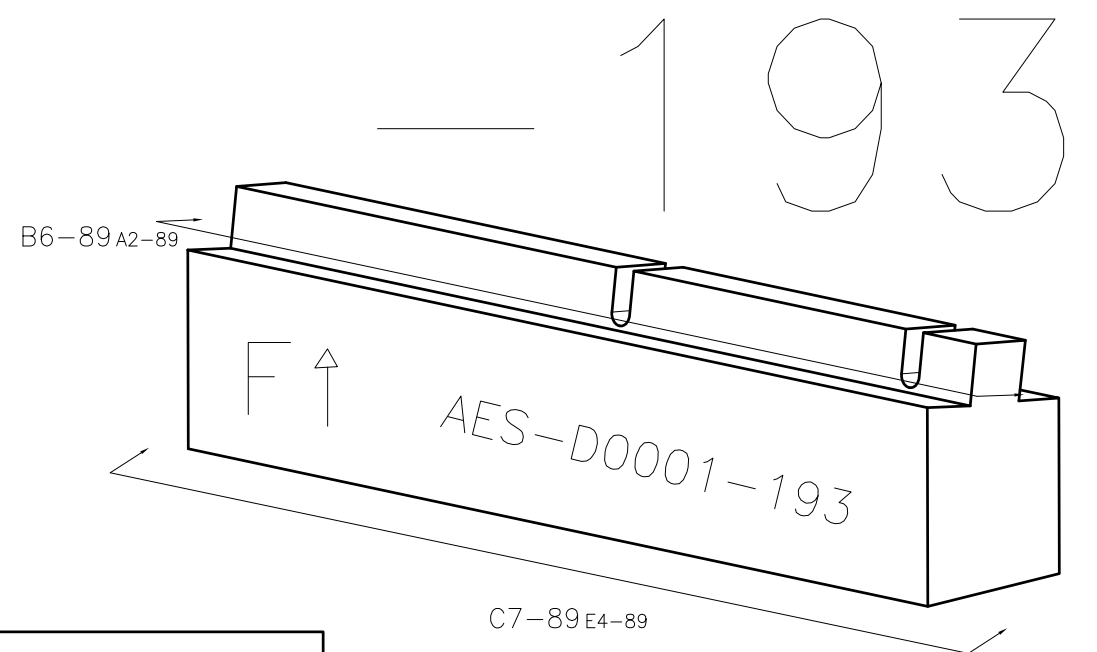

VIEW C7-89

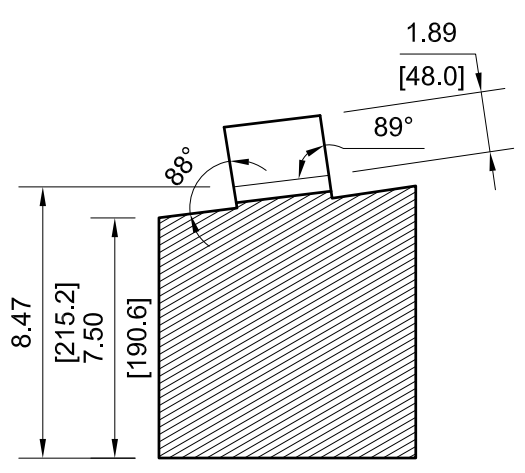

SECTION VIEW E4-89

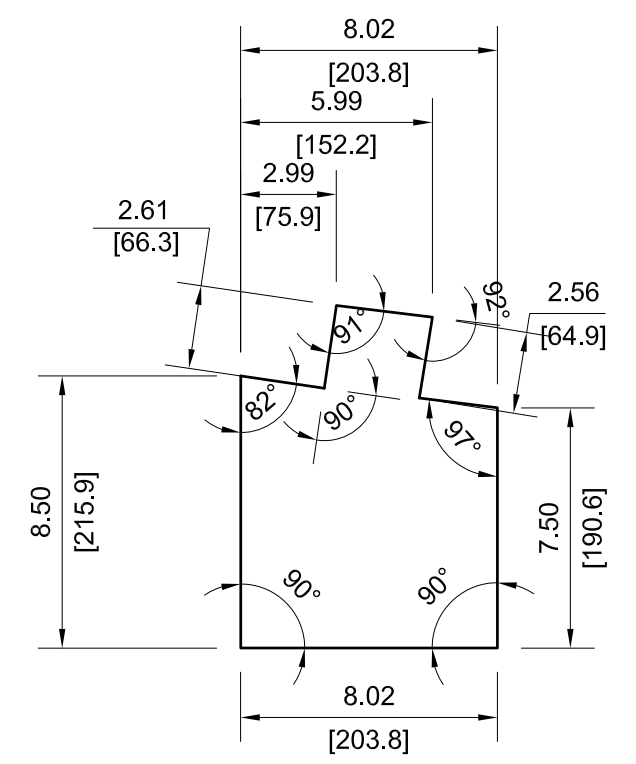

NOTE: ALL VIEWS TAKEN AS TRUE VIEWS PARALLEL TO SURFACE OF PART

	DRAWING NUMBER				
	AES-D0001				
SIZE	SCALE	SHEET	OF	REVISION	
A3	NONE	89	124	E	

195

SECTION VIEW B7-90

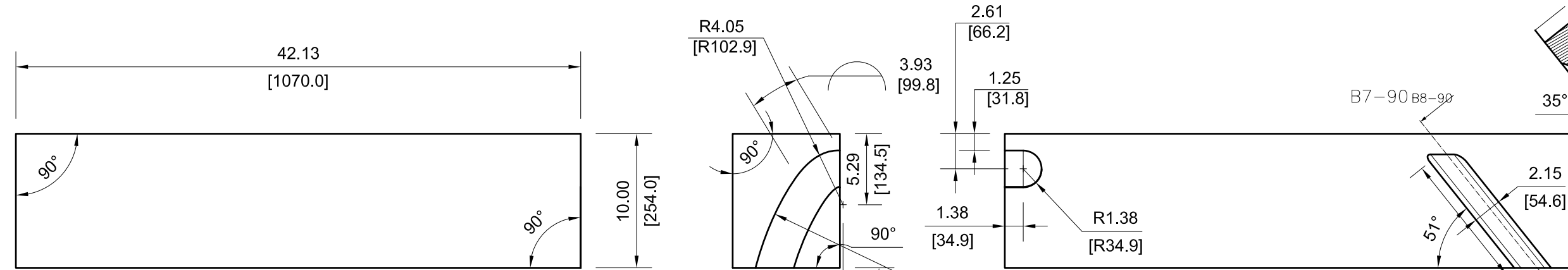
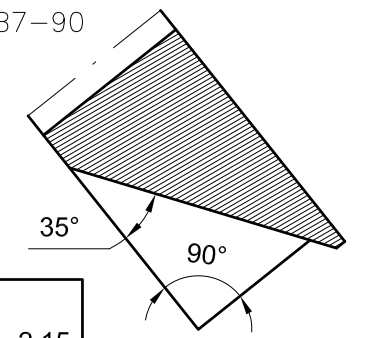

VIEW E8-90

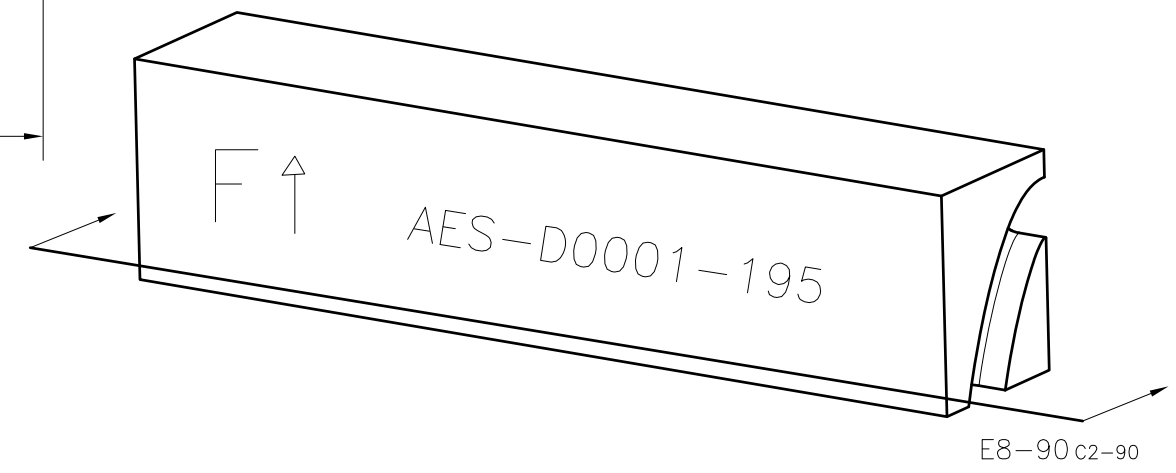
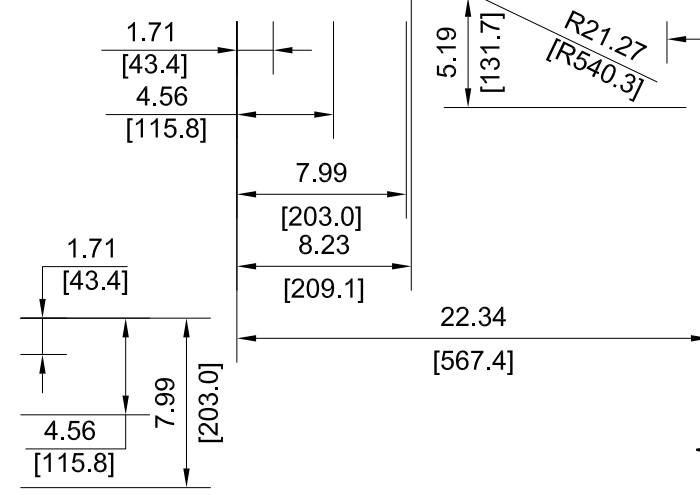
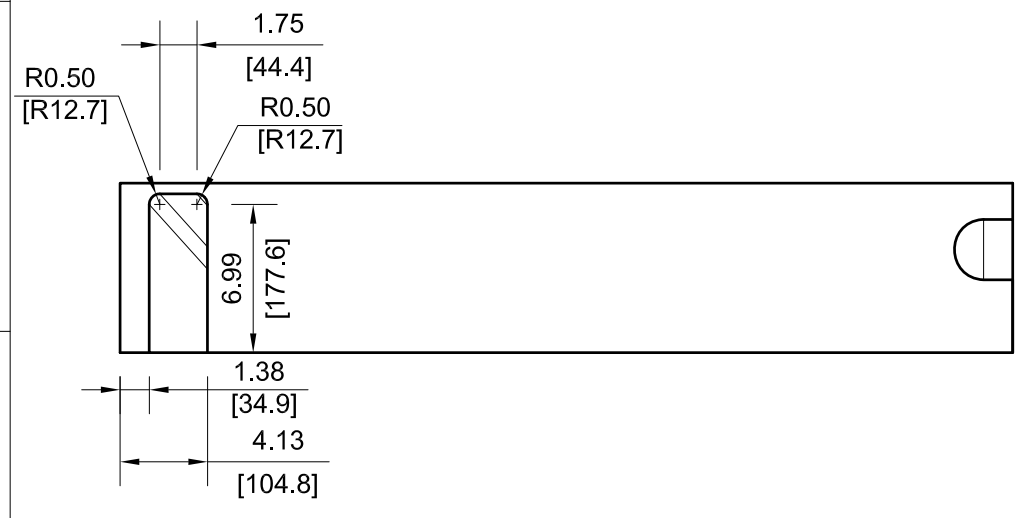

NOTE: ALL VIEWS TAKEN AS TRUE VIEWS PARALLEL TO SURFACE OF PART

	DRAWING NUMBER				
	AES-D0001				
SIZE	SCALE	SHEET	OF	REVISION	
A3	NONE	90	124	E	

197

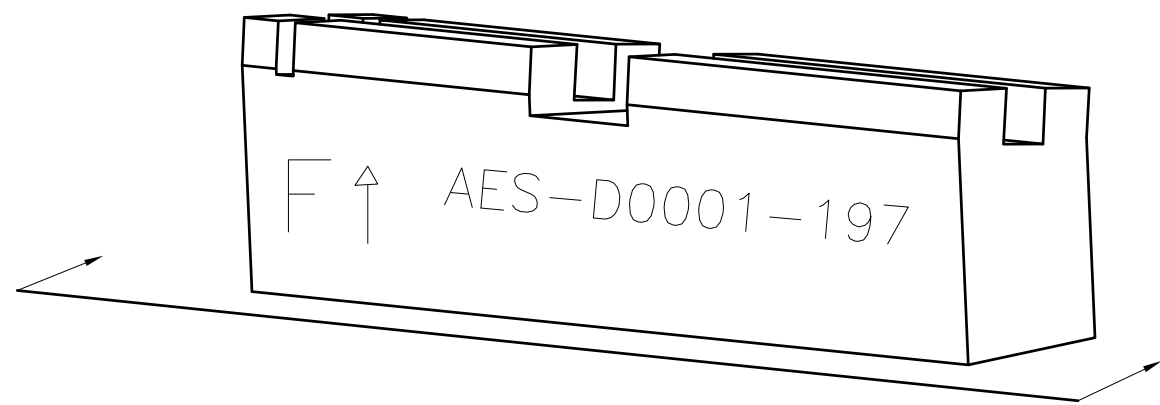

C8-91E5-91

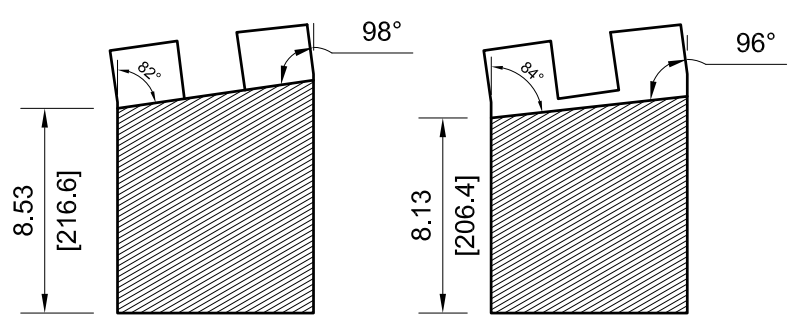
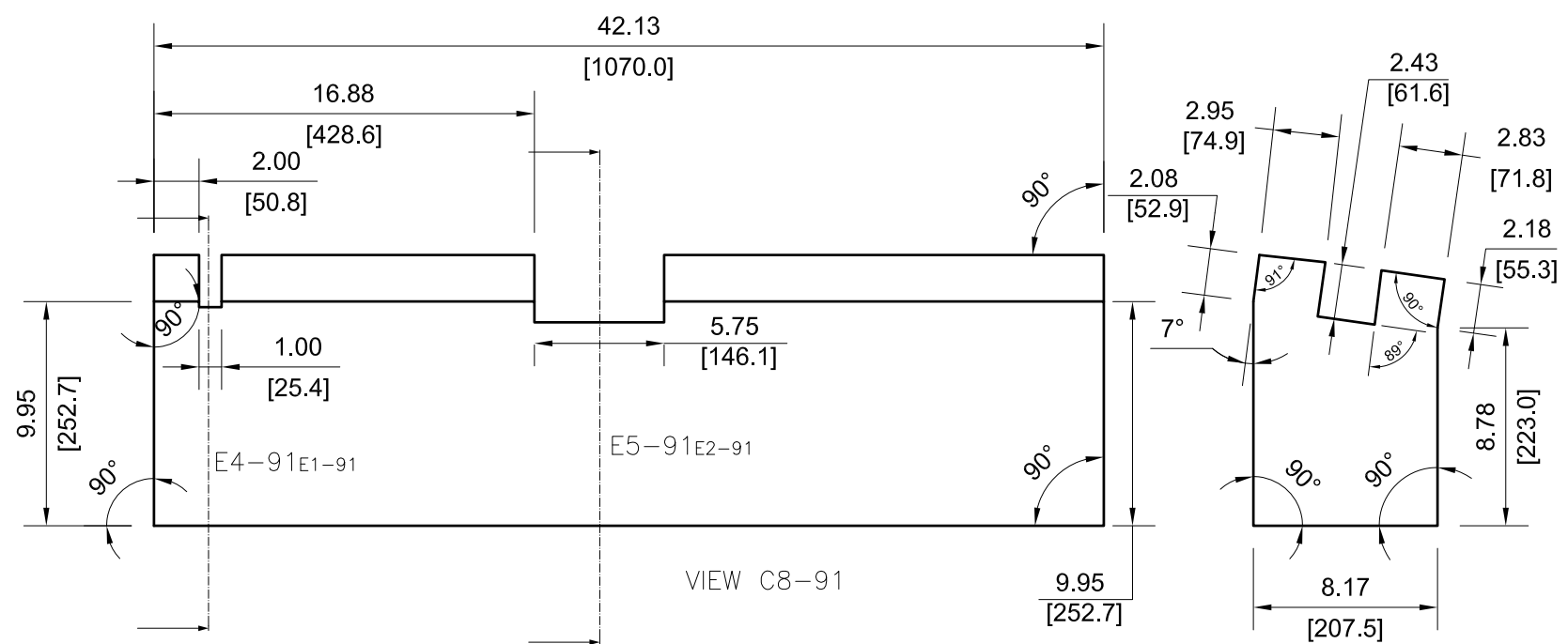
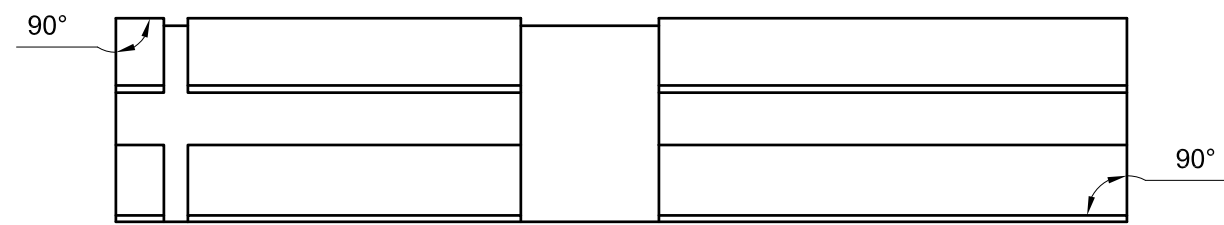

SECTION VIEW E4-91

SECTION VIEW E2-91

VIEW C8-91

NOTE: ALL VIEWS TAKEN AS TRUE VIEWS PARALLEL TO SURFACE OF PART



DRAWING NUMBER					AES-D0001	
SIZE	SCALE	SHEET	OF	REVISION		
A3	NONE	91	124	E		

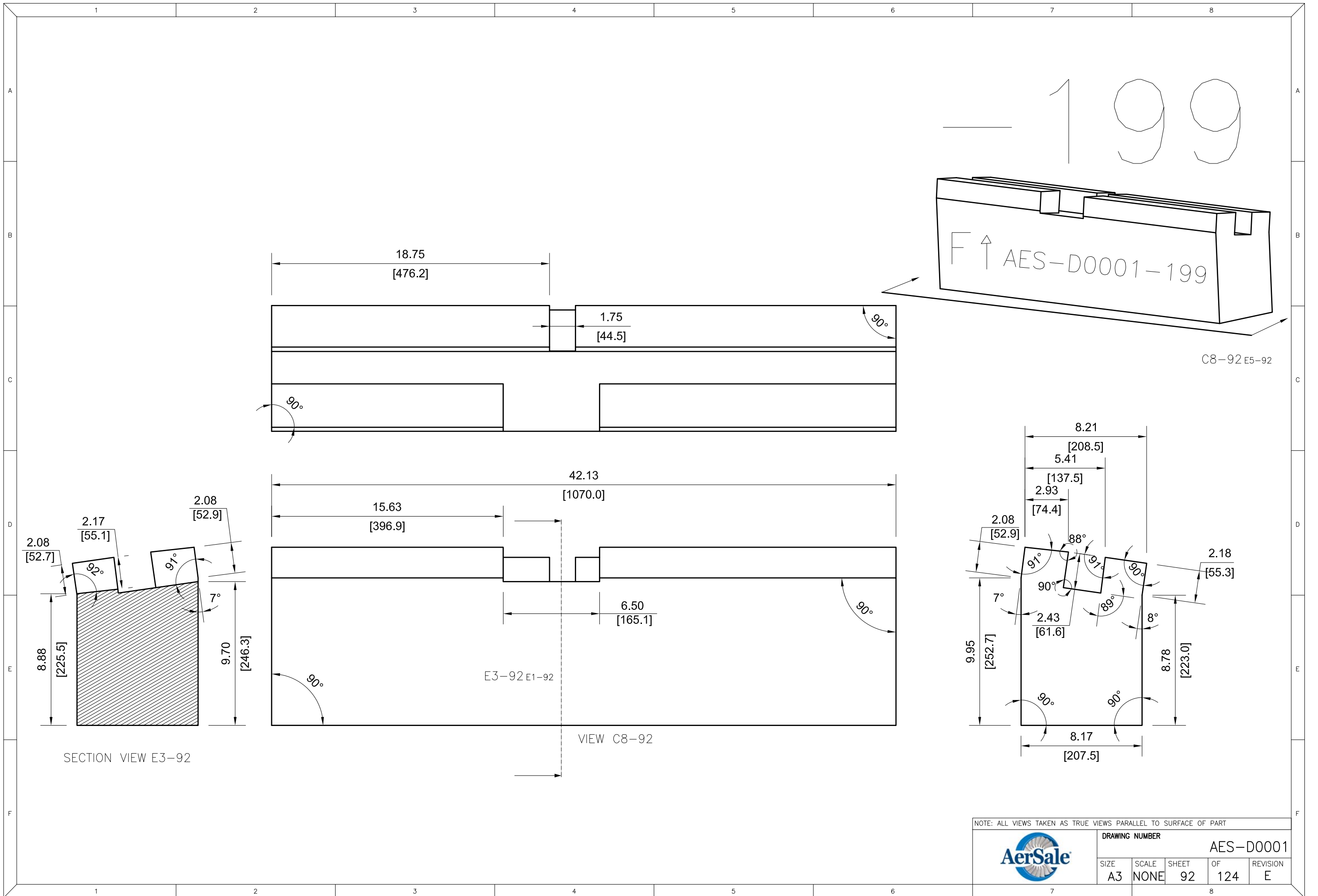

— 201

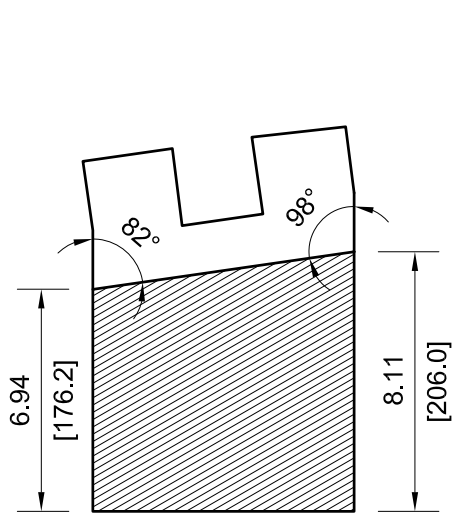
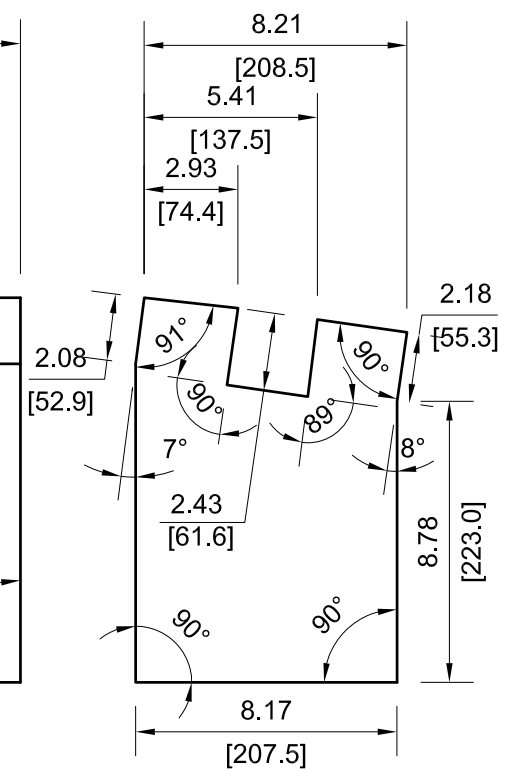
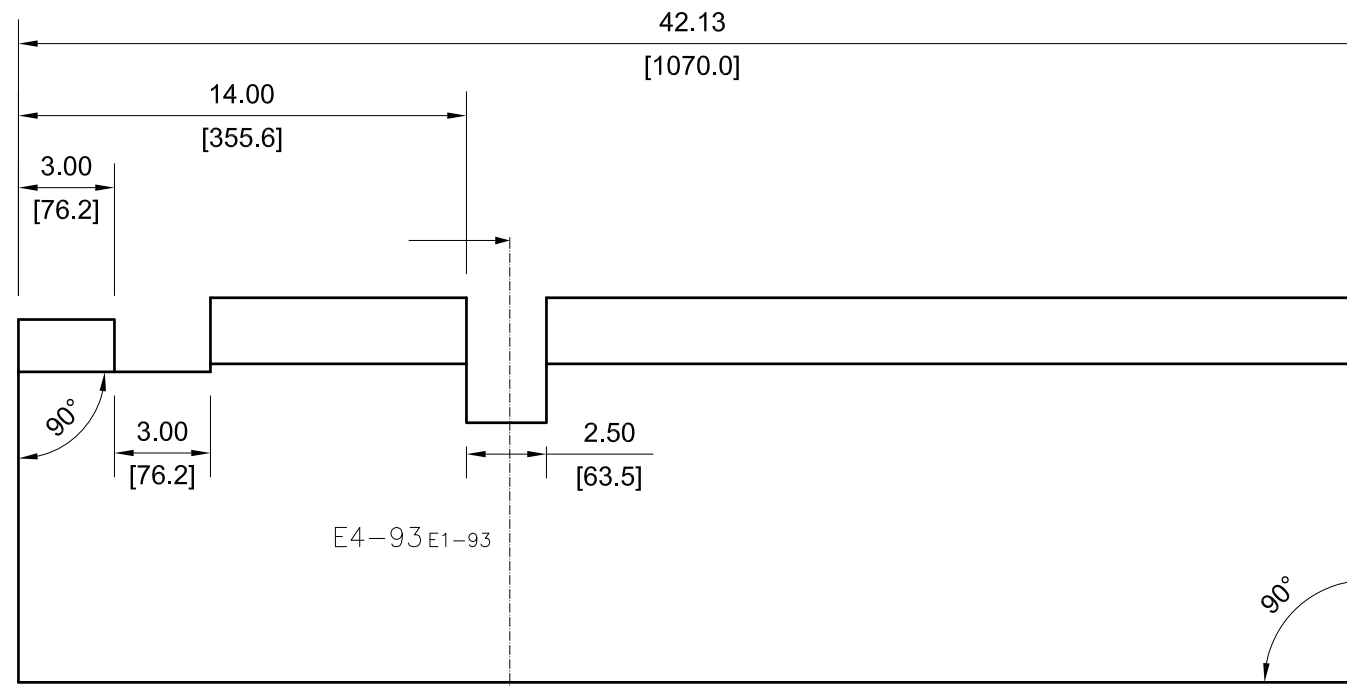
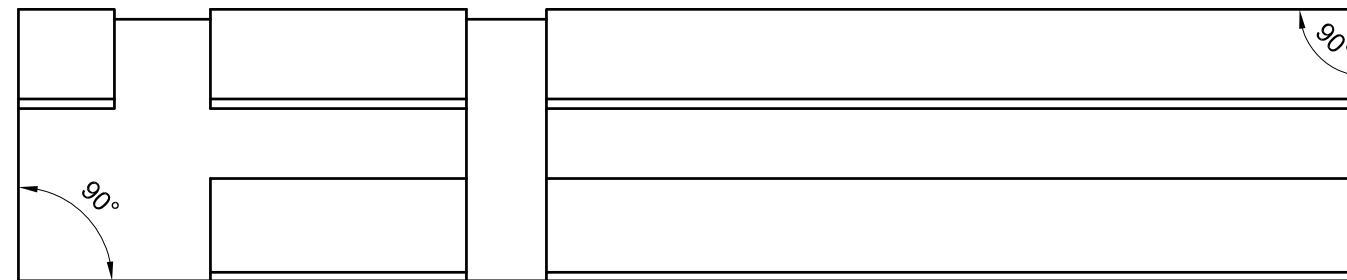
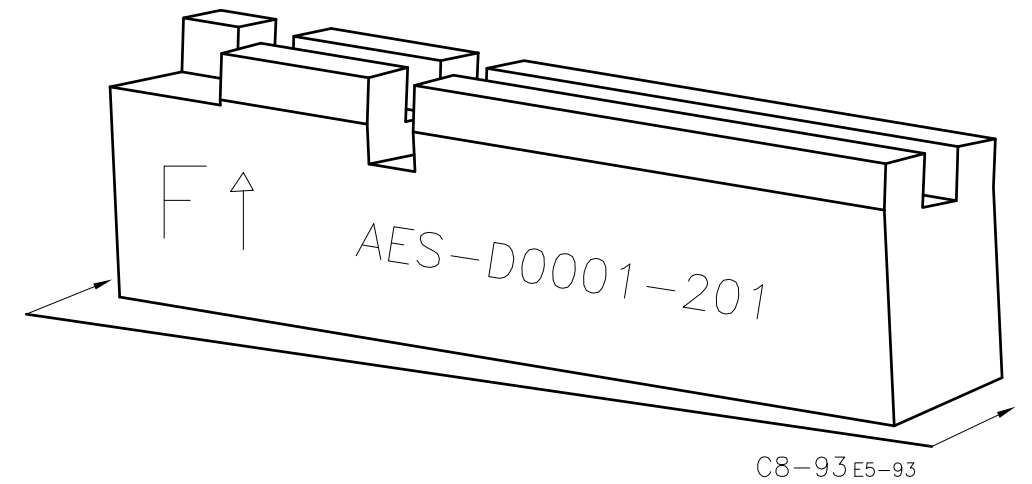

SECTION VIEW E4-93

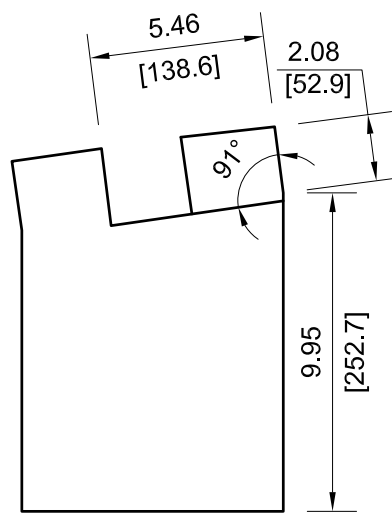

8.17 [207.5]

VIEW C8-93

NOTE: ALL VIEWS TAKEN AS TRUE VIEWS PARALLEL TO SURFACE OF PART



DRAWING NUMBER				
AES-D0001				
SIZE	SCALE	SHEET	OF	REVISION
A3	NONE	93	124	E

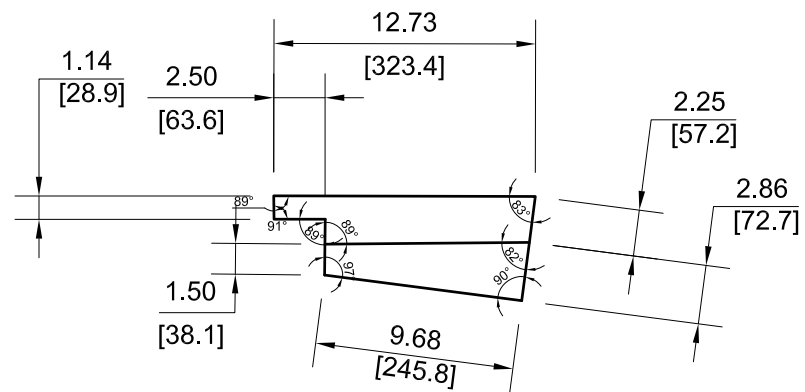

VIEW D6-94

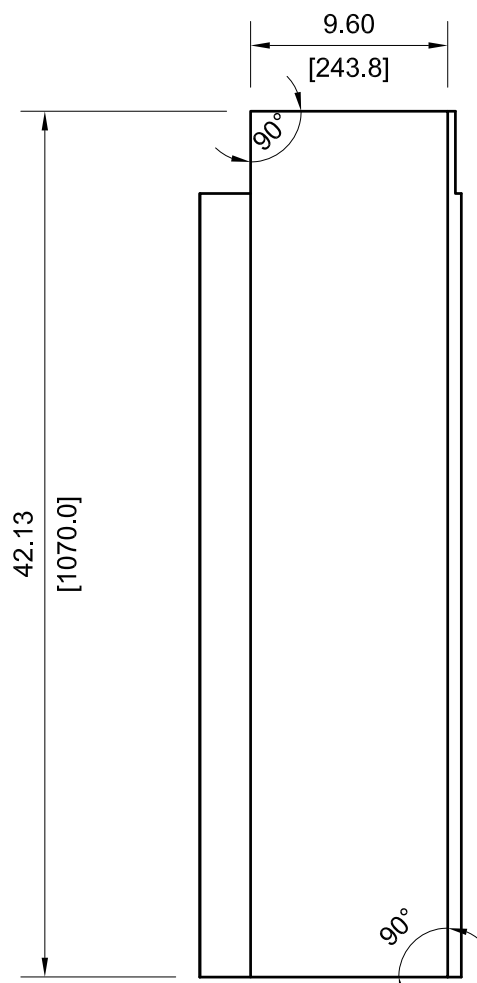

VIEW C7-94

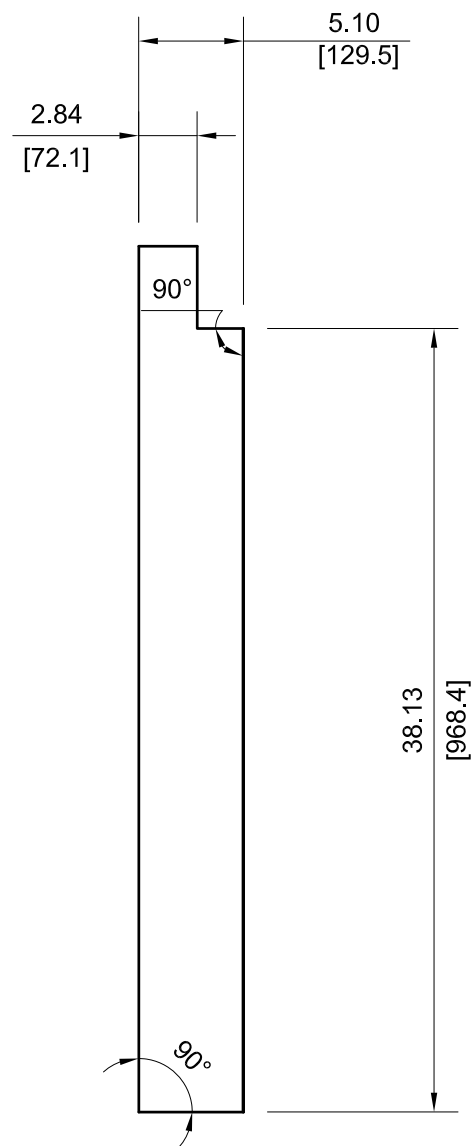

VIEW E6-94

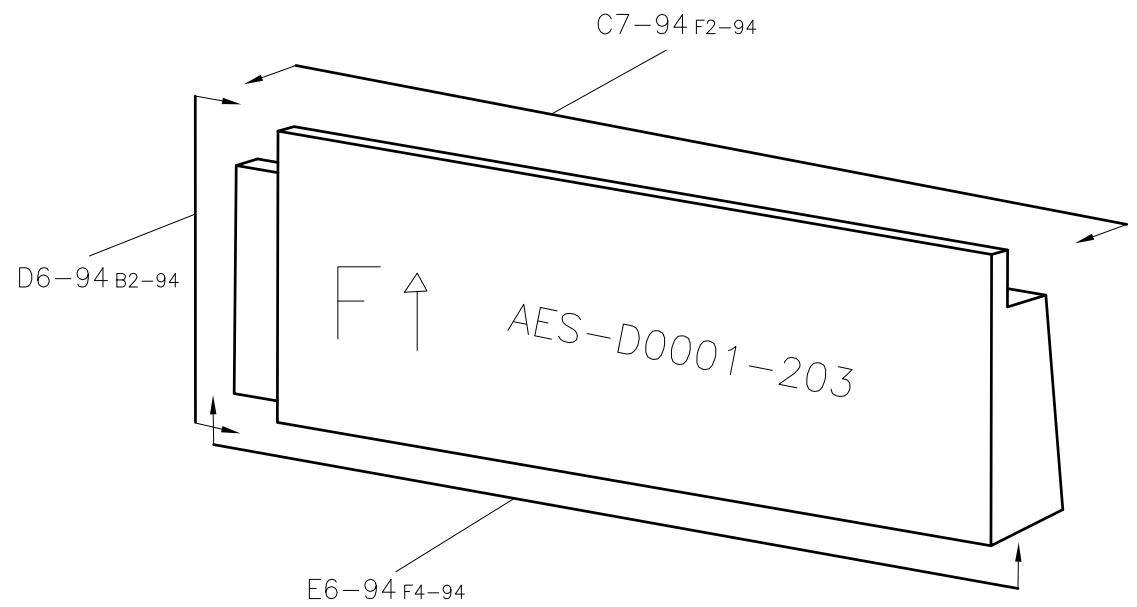

— 203

NOTE: ALL VIEWS TAKEN AS TRUE VIEWS PARALLEL TO SURFACE OF PART

	DRAWING NUMBER				
	AES-D0001				
SIZE	SCALE	SHEET	OF	REVISION	
A3	NONE	94	124	E	

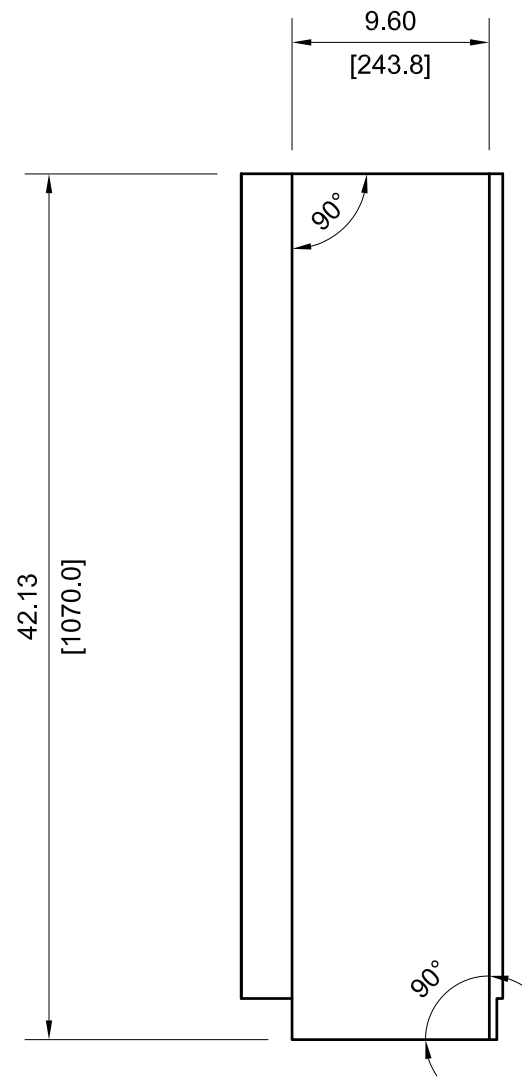

VIEW D7-95

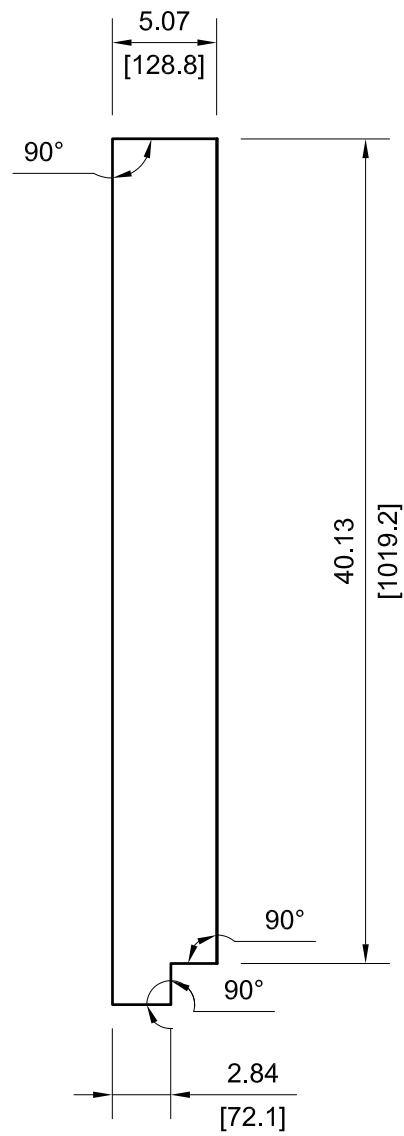

VIEW E7-95

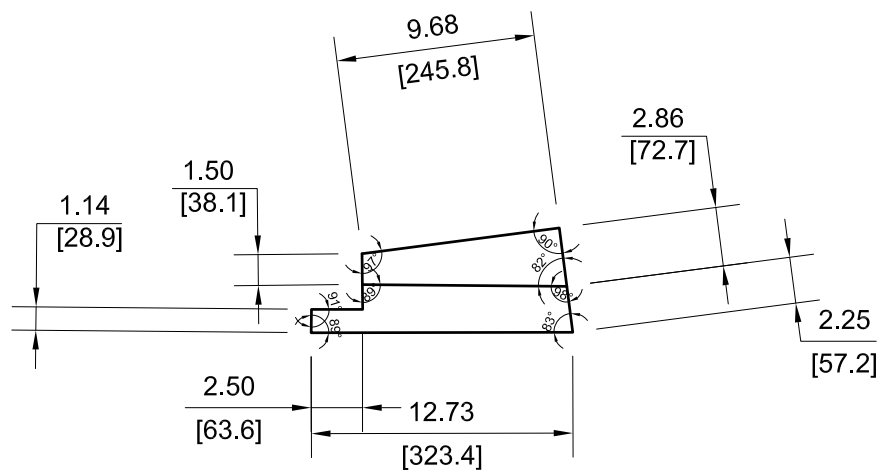

VIEW E8-95

— 205

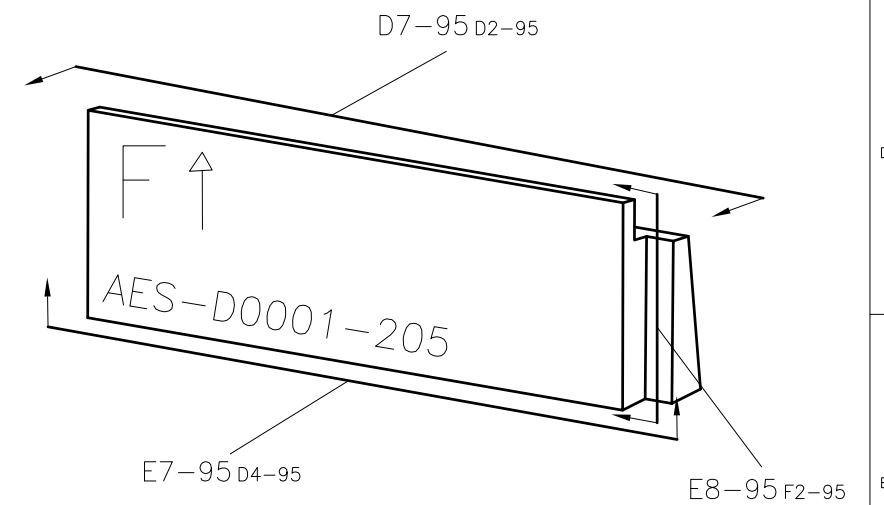

NOTE: ALL VIEWS TAKEN AS TRUE VIEWS PARALLEL TO SURFACE OF PART

	DRAWING NUMBER				
	AES-D0001				
SIZE	SCALE	SHEET	OF	REVISION	
A3	NONE	95	124	E	

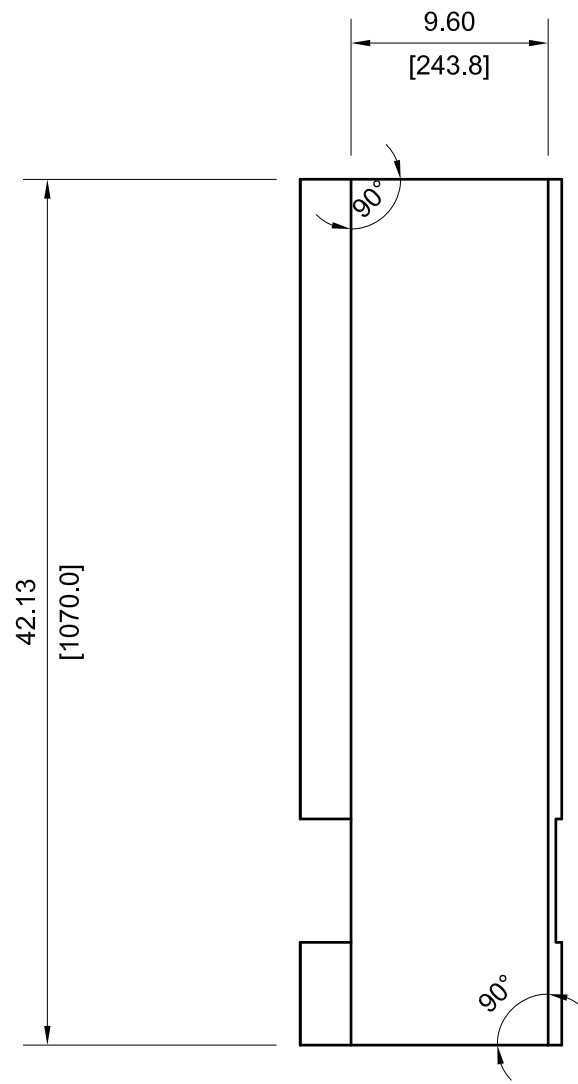

VIEW C7-96

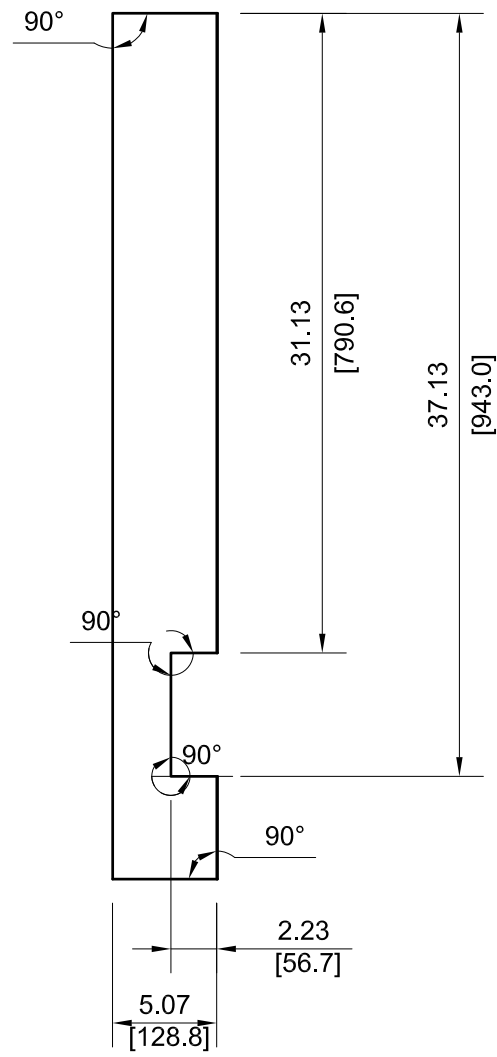

VIEW D6-96

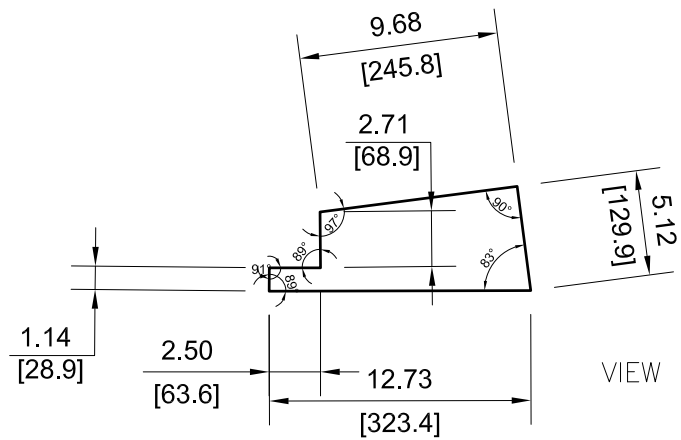

VIEW F8-96

— 207

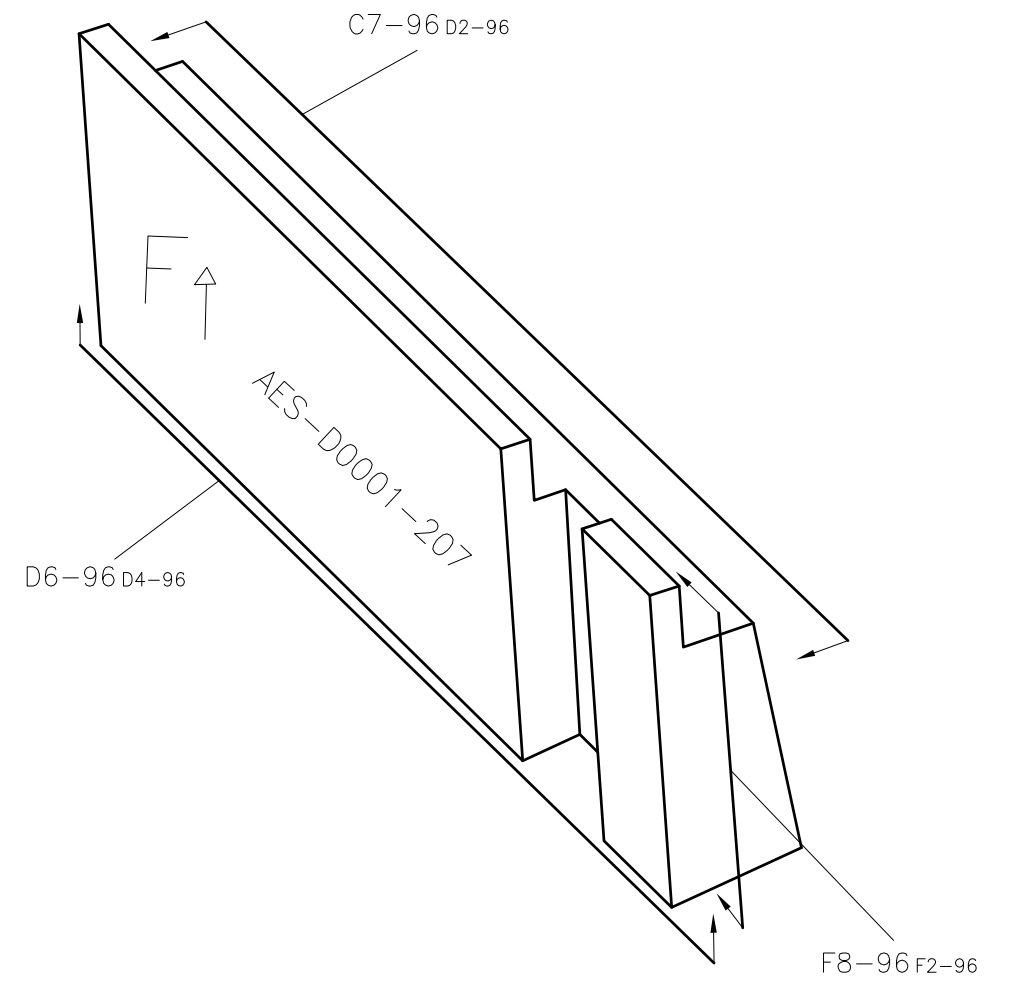

NOTE: ALL VIEWS TAKEN AS TRUE VIEWS PARALLEL TO SURFACE OF PART



DRAWING NUMBER					AES-D0001				
SIZE	SCALE	SHEET	OF	REVISION					
A3	NONE	96	124	E					

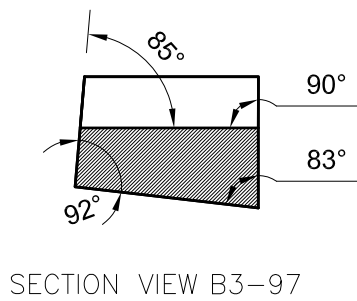
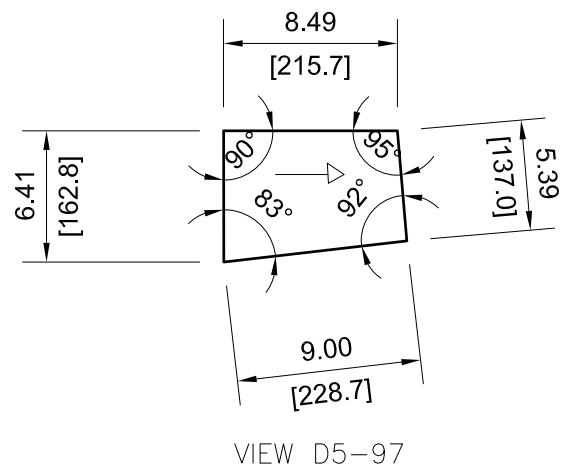
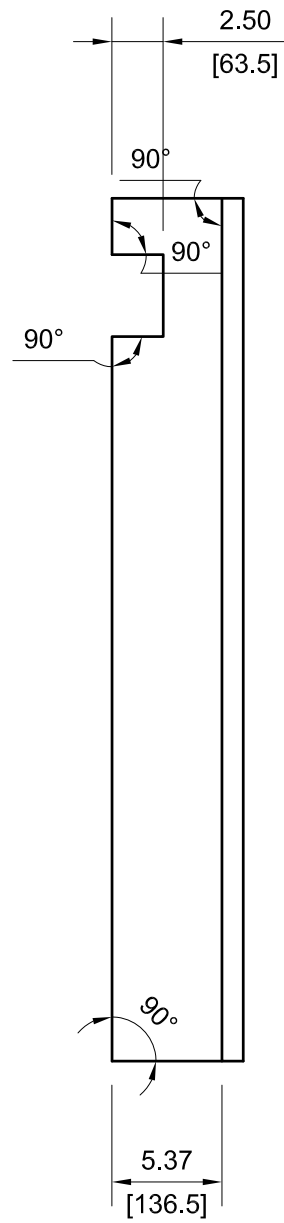
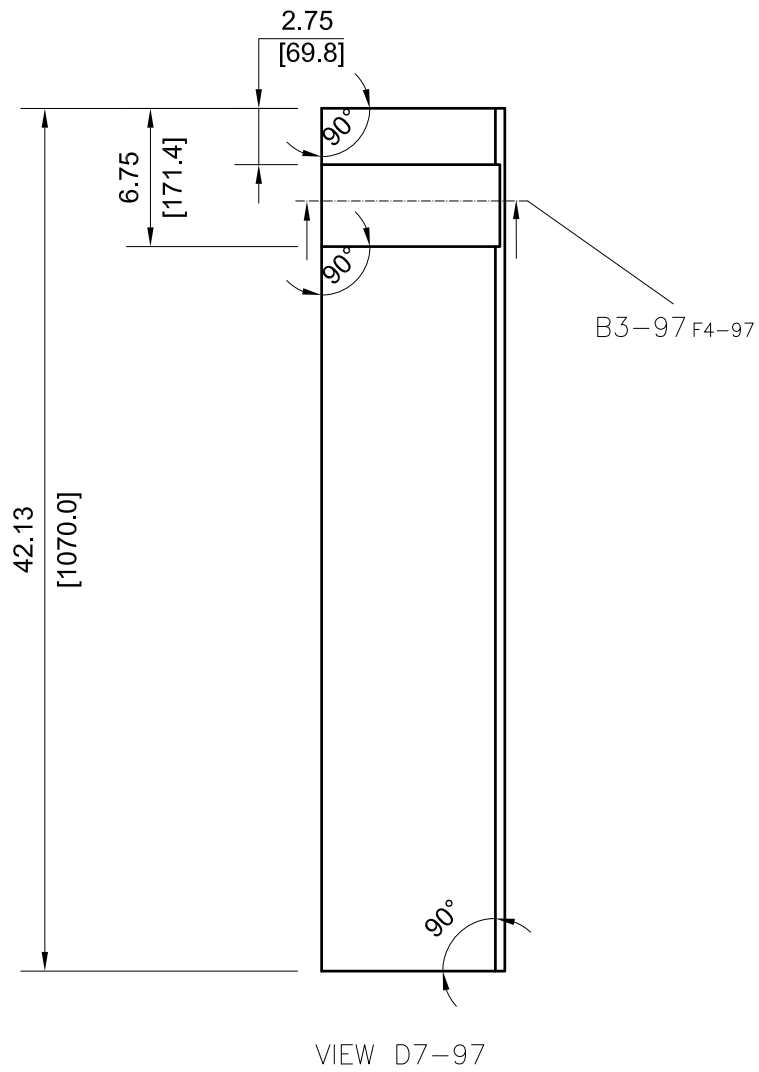

— 2009

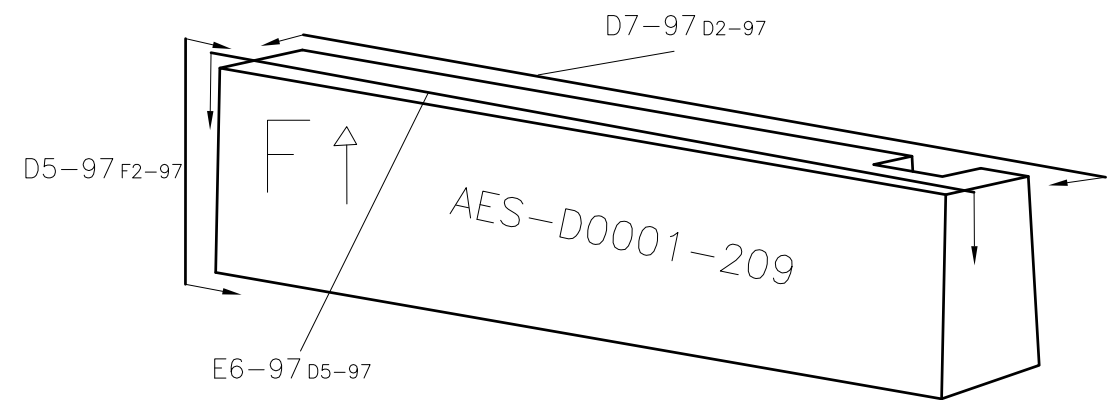

NOTE: ALL VIEWS TAKEN AS TRUE VIEWS PARALLEL TO SURFACE OF PART

	DRAWING NUMBER				
	AES-D0001				
SIZE	SCALE	SHEET	OF	REVISION	
A3	NONE	97	124	E	

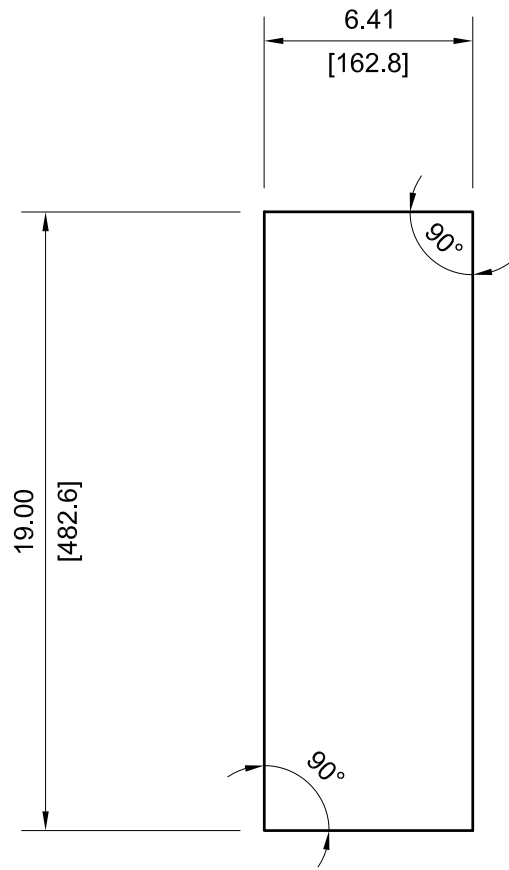

VIEW E6-98

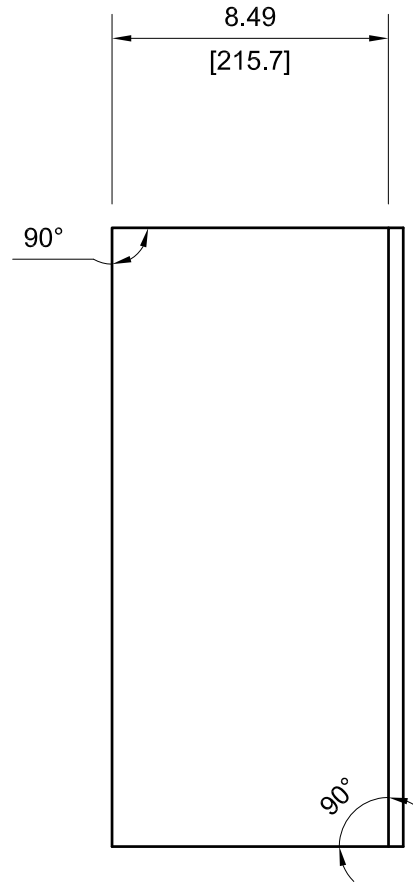

VIEW D7-98

— 211

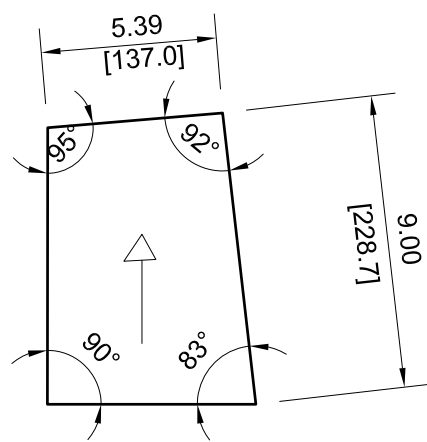

VIEW D6-98

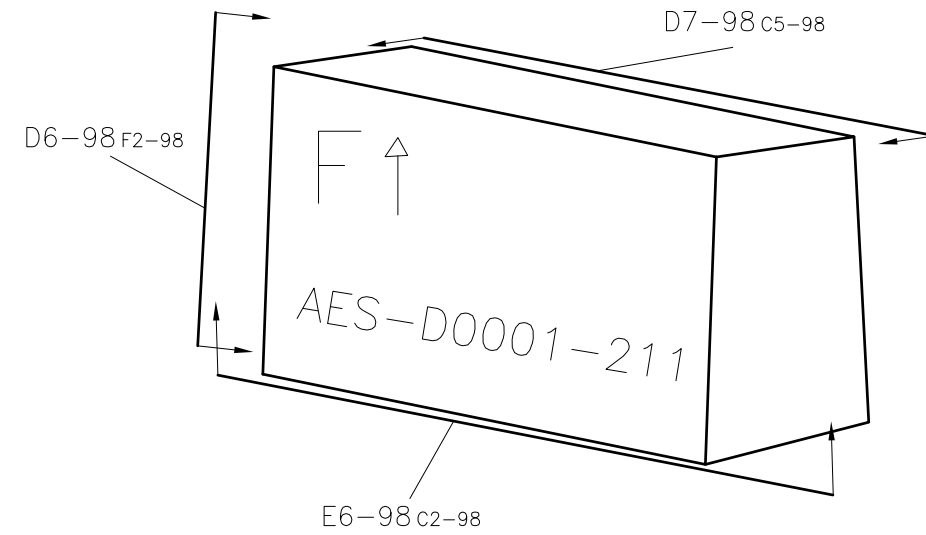

NOTE: ALL VIEWS TAKEN AS TRUE VIEWS PARALLEL TO SURFACE OF PART



DRAWING NUMBER					AES-D0001	
SIZE	SCALE	SHEET	OF	REVISION		
A3	NONE	98	124	E		

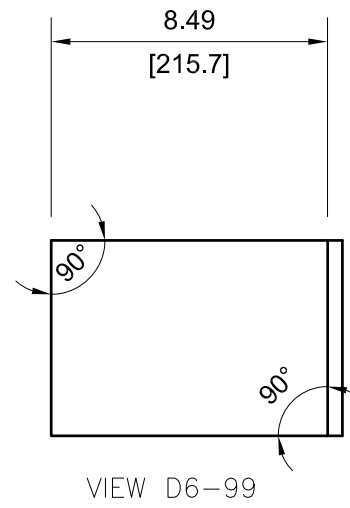
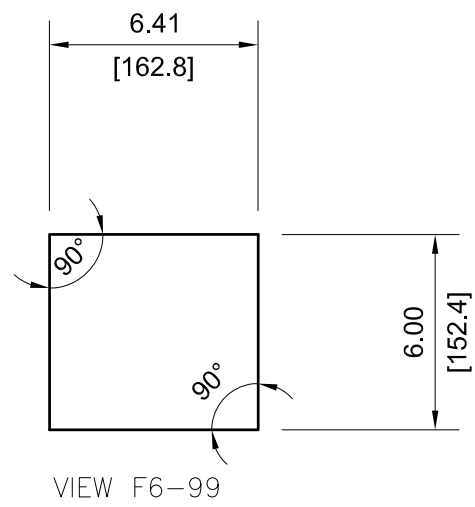

- 213

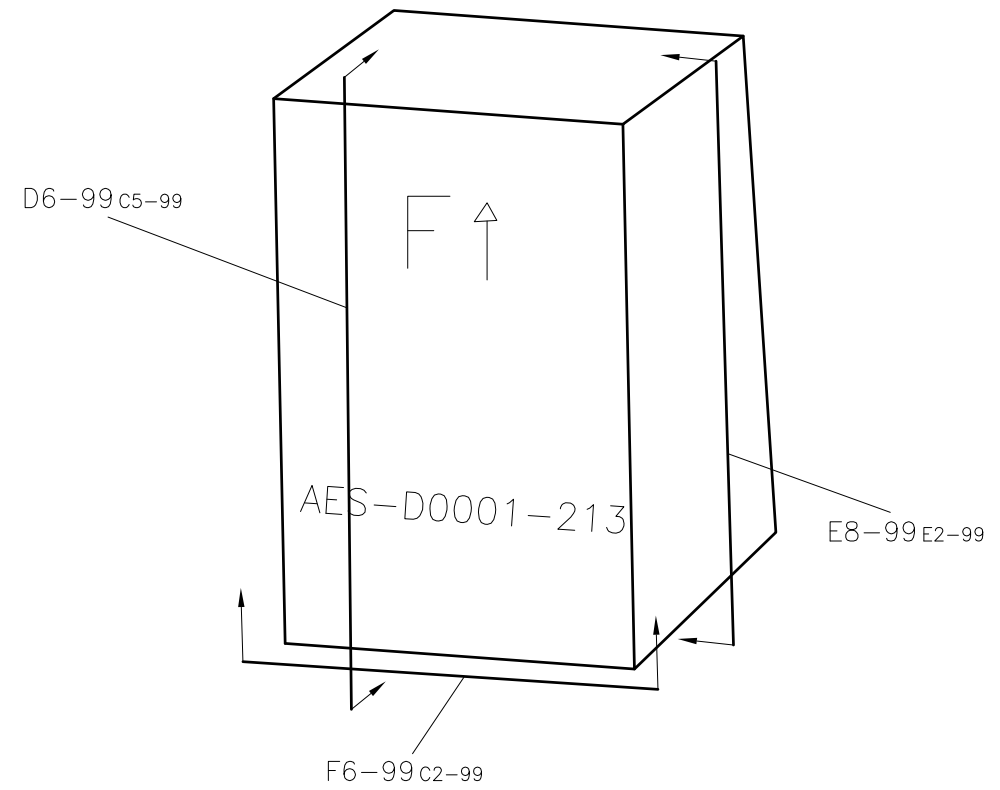
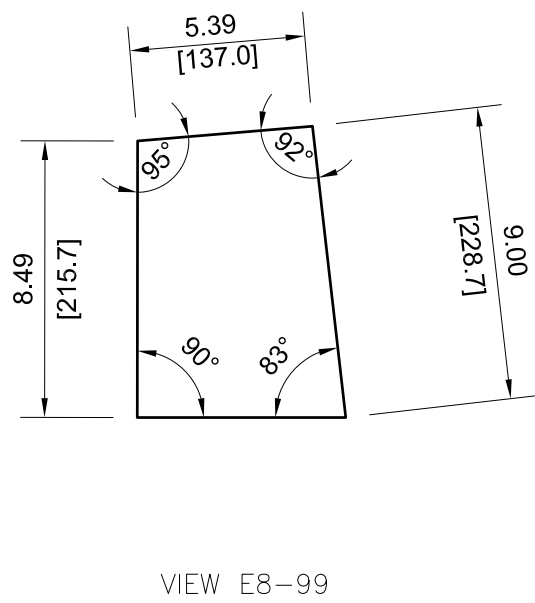

NOTE: ALL VIEWS TAKEN AS TRUE VIEWS PARALLEL TO SURFACE OF PART

	DRAWING NUMBER				AES-D0001
	SIZE	SCALE	SHEET	OF	REVISION
A3	NONE	99	124	E	

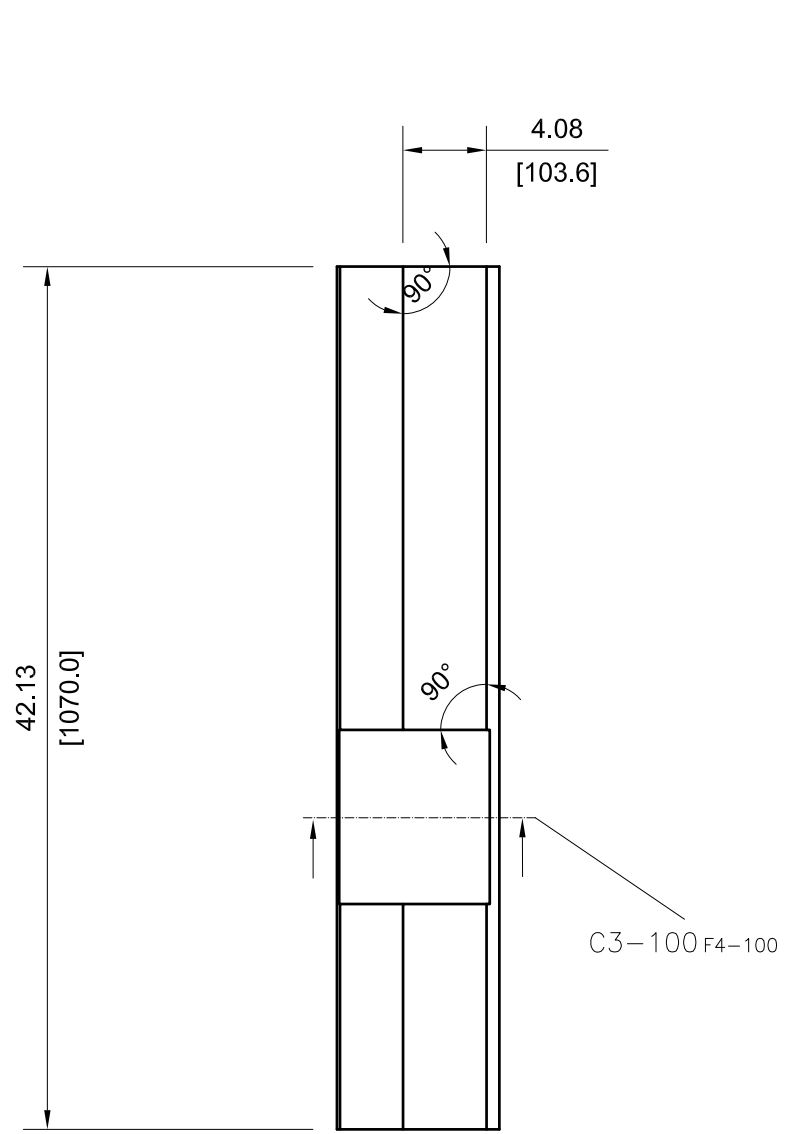

VIEW E6-100

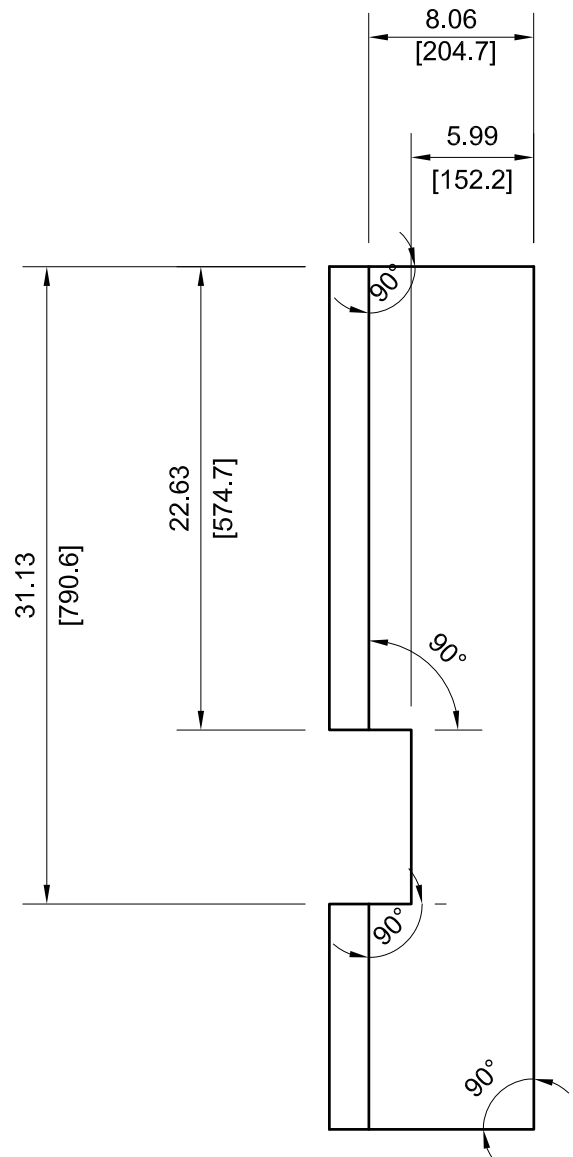

VIEW D7-100

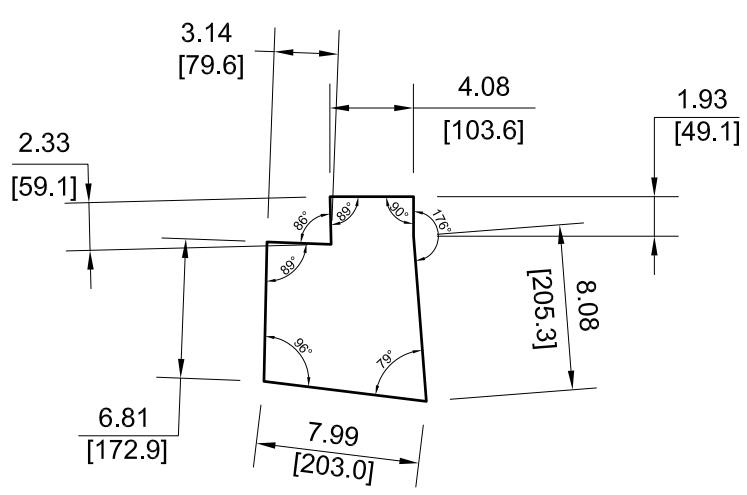

VIEW E8-100

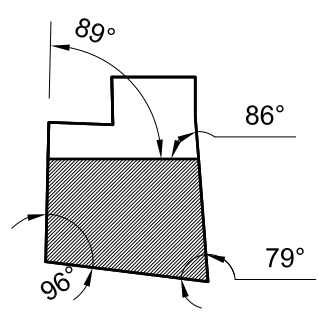

SECTION VIEW C3-100

— 215

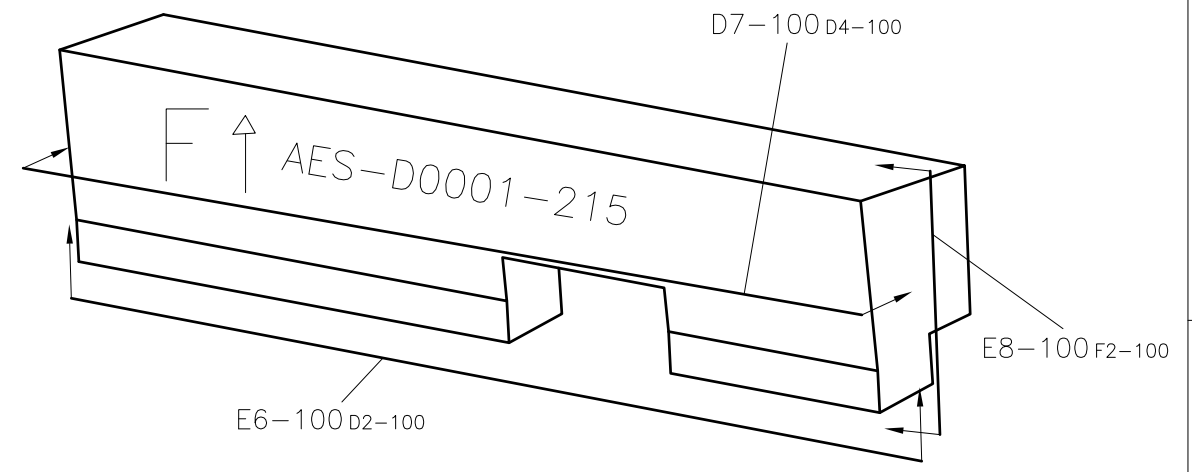

NOTE: ALL VIEWS TAKEN AS TRUE VIEWS PARALLEL TO SURFACE OF PART



DRAWING NUMBER					AES-D0001	
SIZE	SCALE	SHEET	OF	REVISION		
A3	NONE	100	124	E		

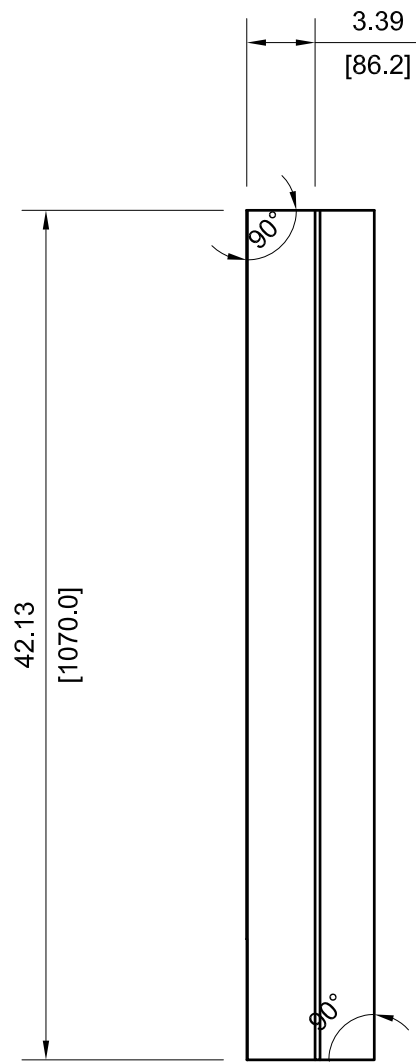

VIEW D7-101

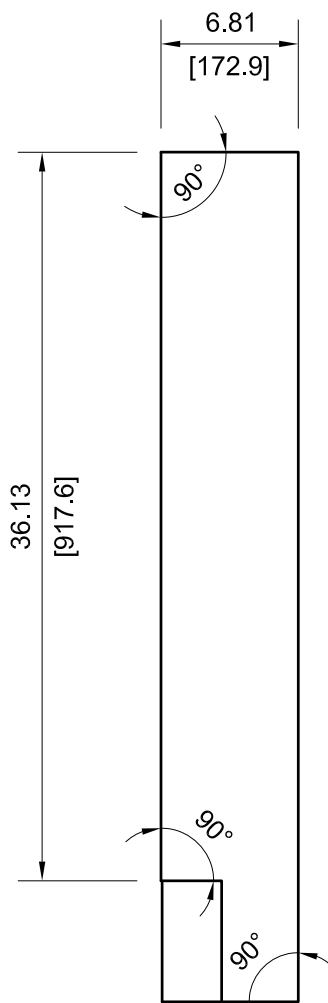

VIEW E5-101

— 217

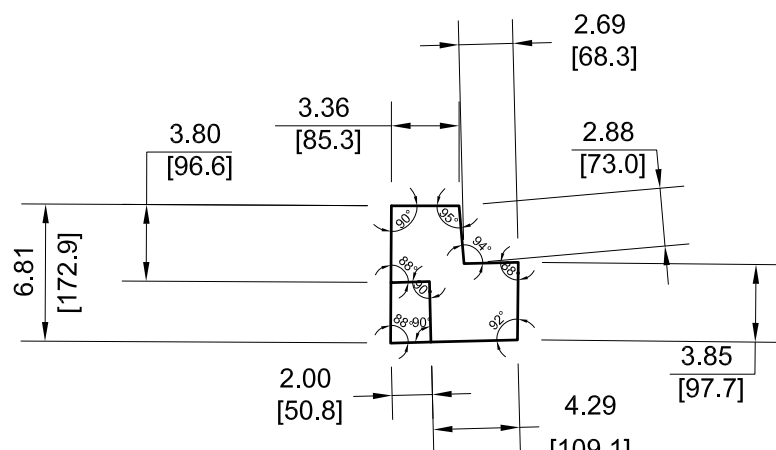

VIEW E8-101

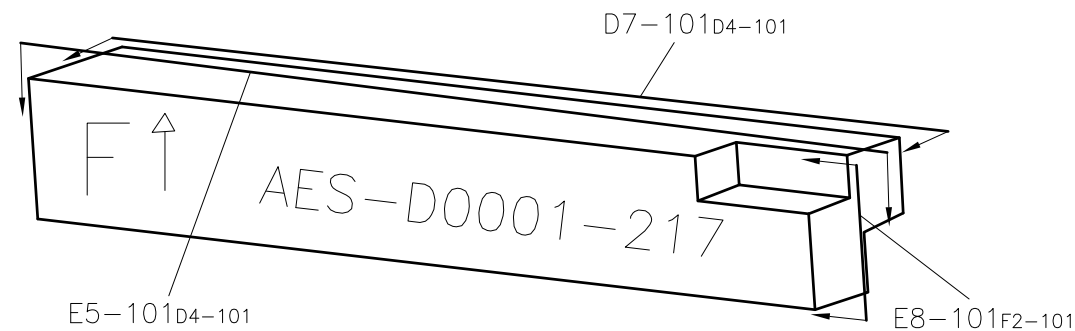

NOTE: ALL VIEWS TAKEN AS TRUE VIEWS PARALLEL TO SURFACE OF PART



DRAWING NUMBER					AES-D0001	
SIZE	SCALE	SHEET	OF	REVISION		
A3	NONE	101	124	E		

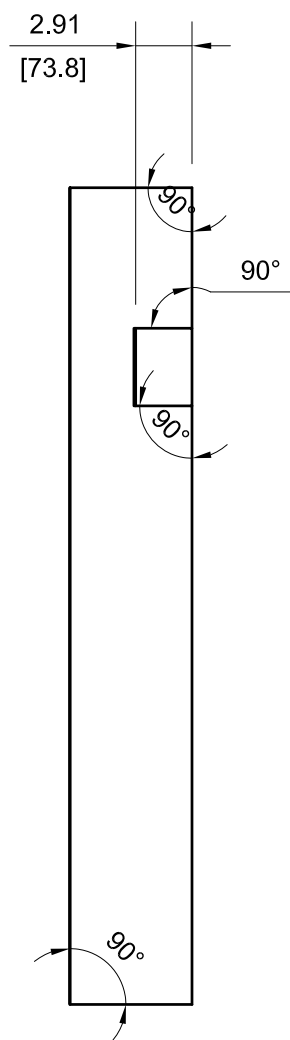

VIEW E7-102

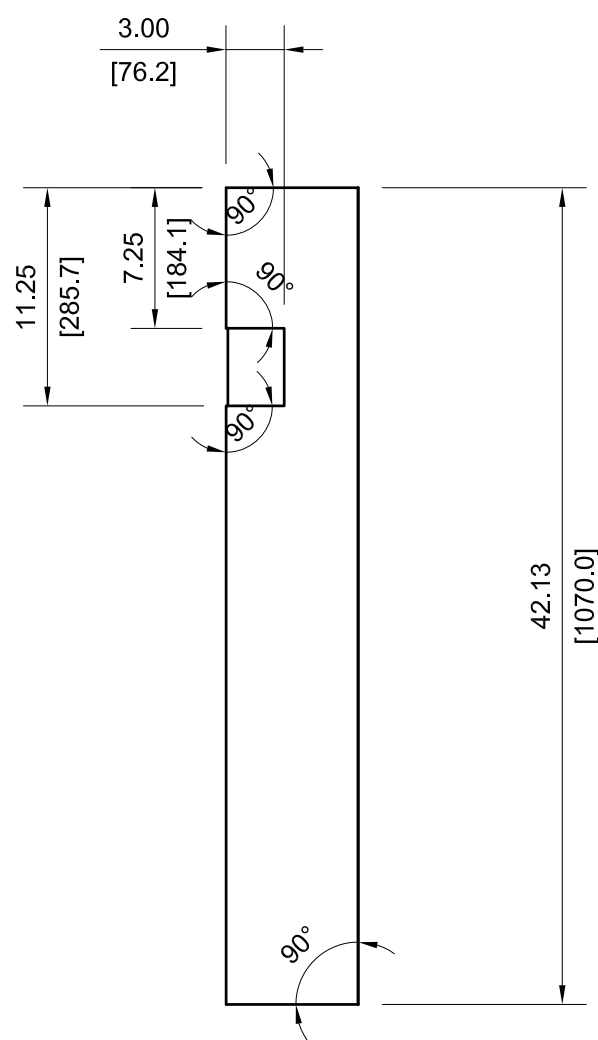

VIEW D8-102

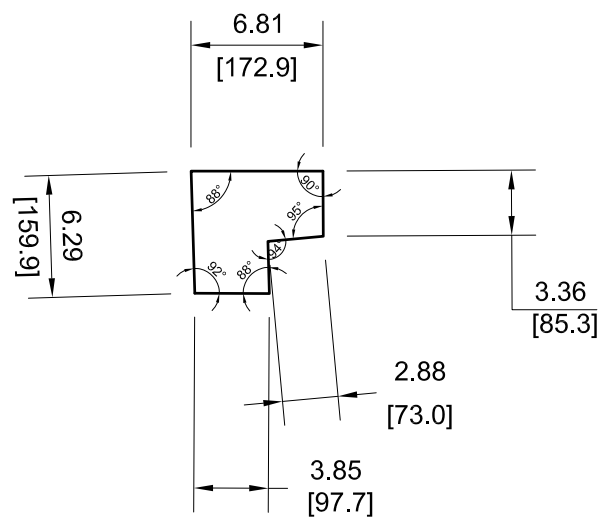

VIEW E8-102

- 219

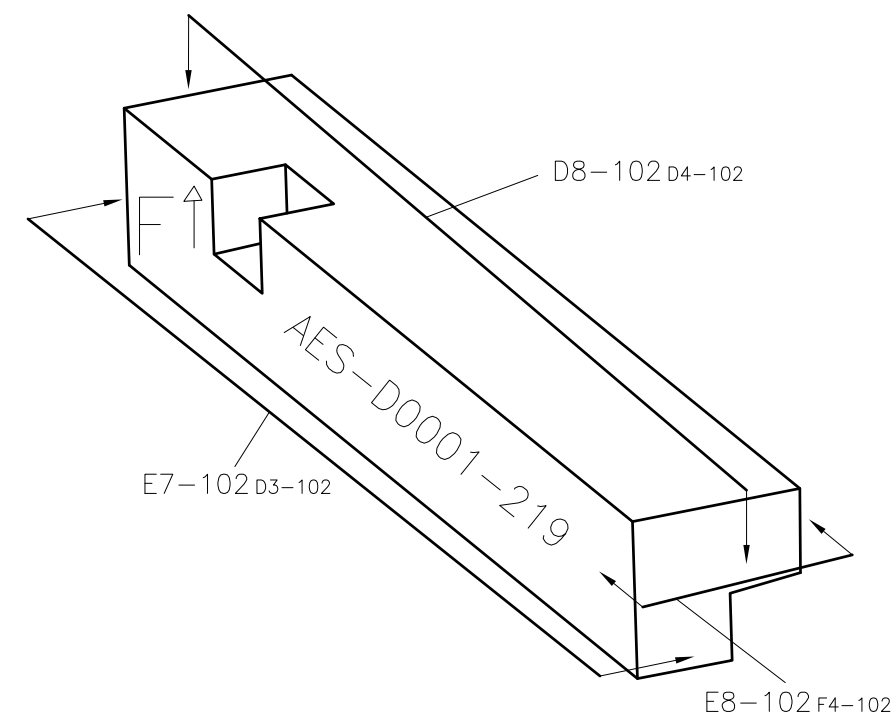

NOTE: ALL VIEWS TAKEN AS TRUE VIEWS PARALLEL TO SURFACE OF PART



DRAWING NUMBER					AES-D0001	
SIZE	SCALE	SHEET	OF	REVISION		
A3	NONE	102	124	E		

— 221

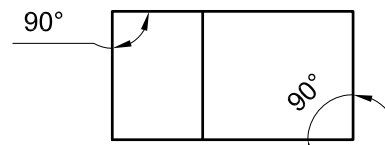

VIEW E8-103

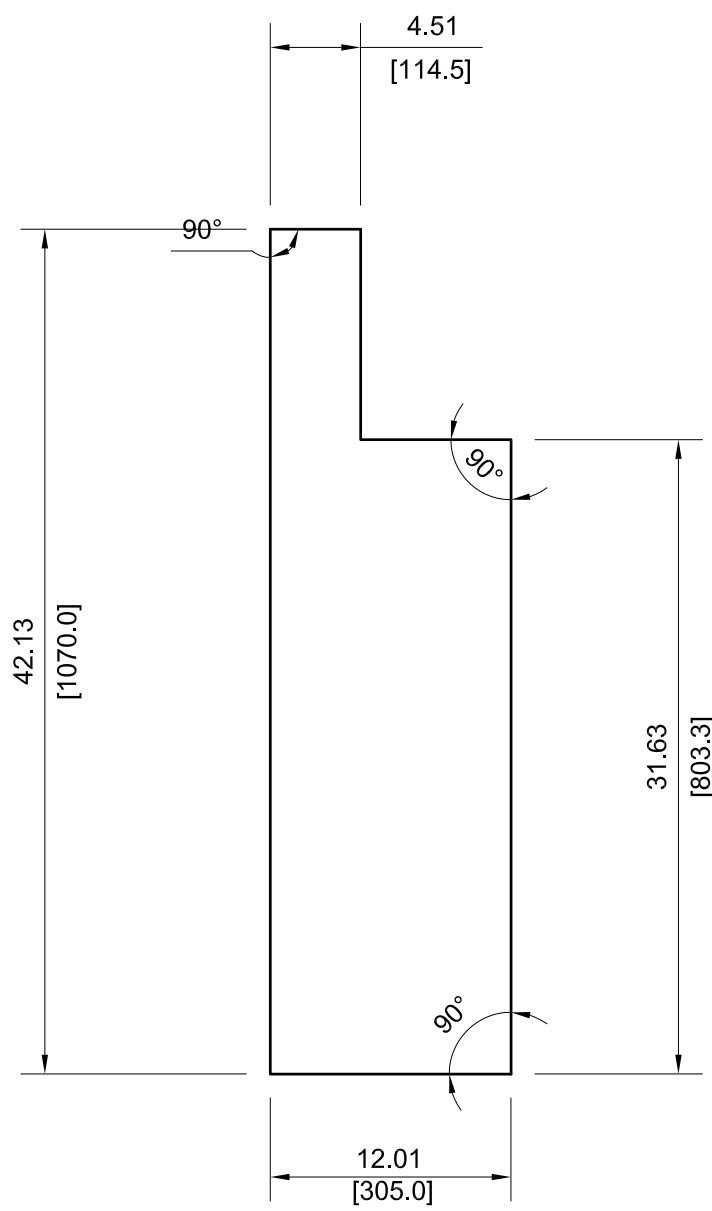

VIEW D5-103

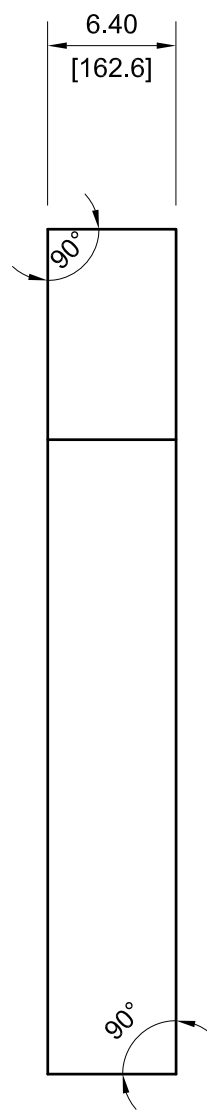

VIEW E6-103

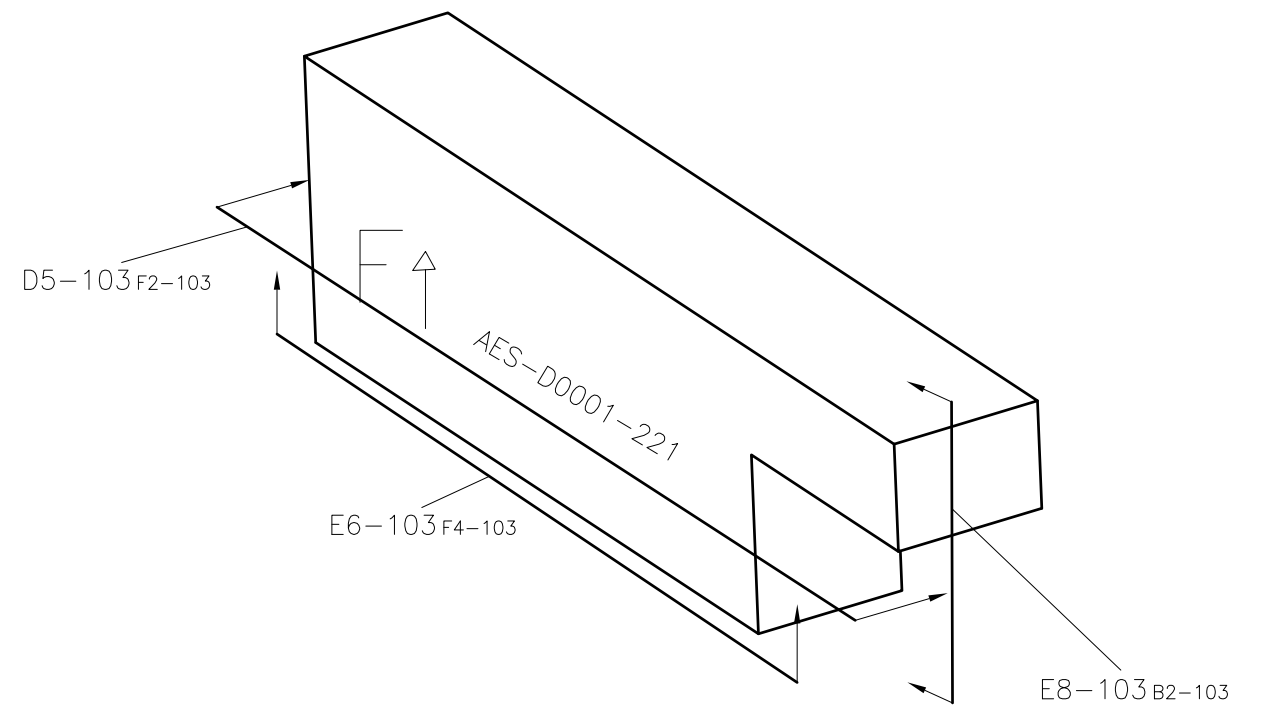

NOTE: ALL VIEWS TAKEN AS TRUE VIEWS PARALLEL TO SURFACE OF PART



DRAWING NUMBER				
AES-D0001				
SIZE	SCALE	SHEET	OF	REVISION
A3	NONE	103	124	E

- 223

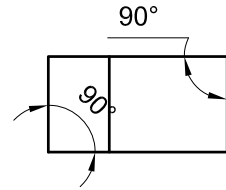

VIEW D6-104

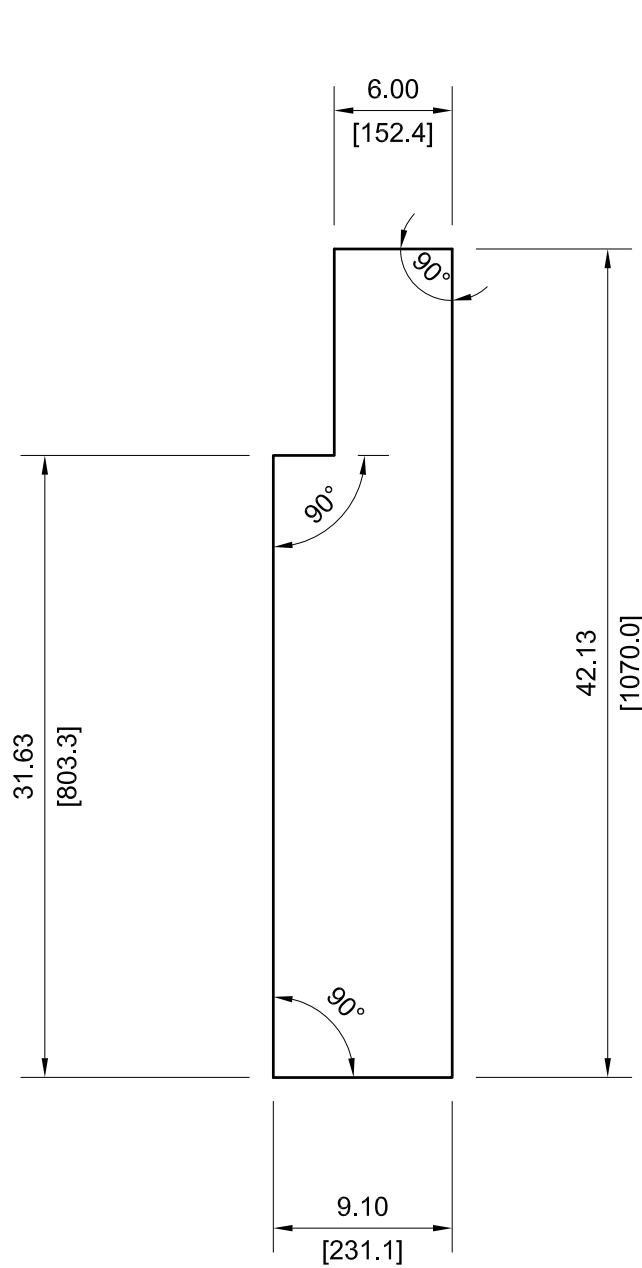

VIEW D8-104

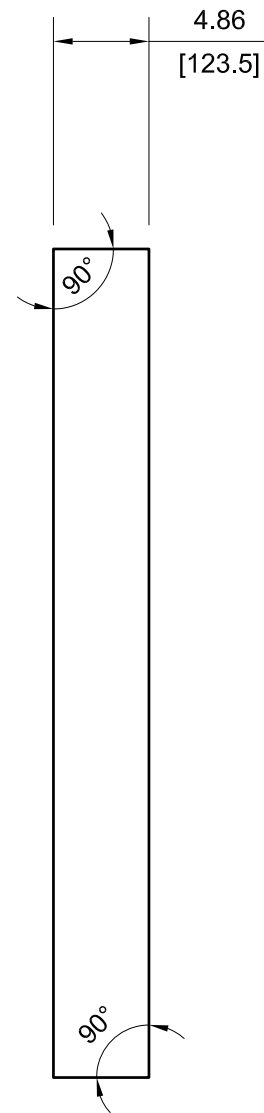

VIEW E7-104

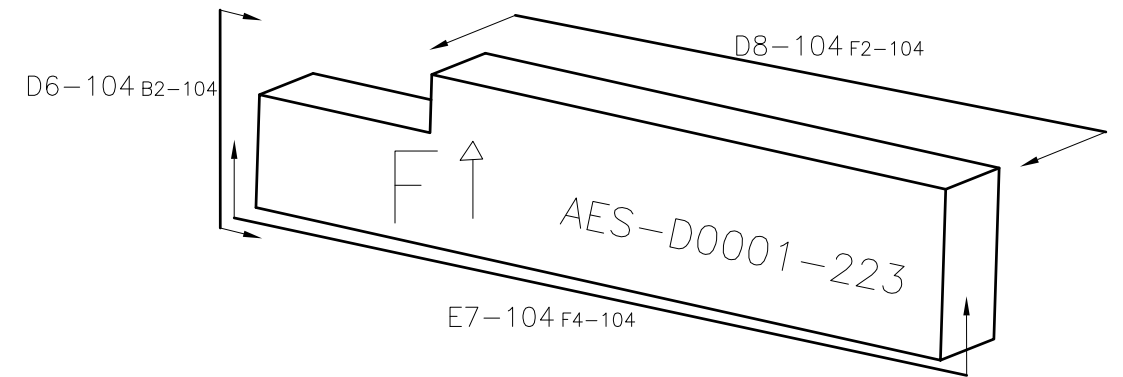

NOTE: ALL VIEWS TAKEN AS TRUE VIEWS PARALLEL TO SURFACE OF PART

		DRAWING NUMBER			
		AES-D0001			
SIZE	SCALE	SHEET	OF	REVISION	
A3	NONE	104	124	E	

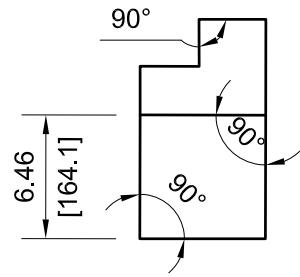

VIEW E5-105

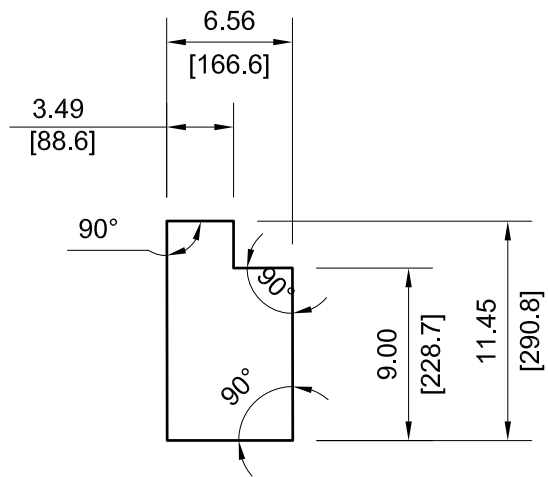

VIEW E8-105

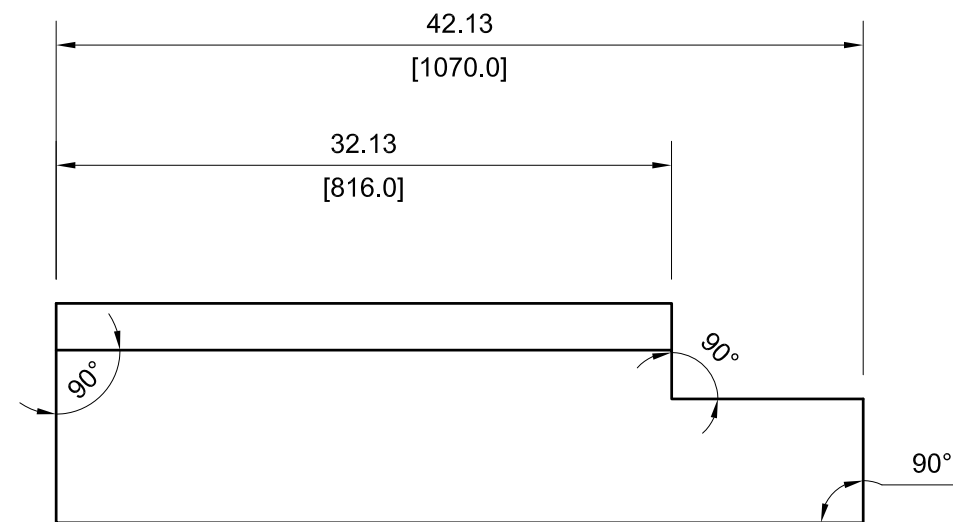

VIEW D7-105

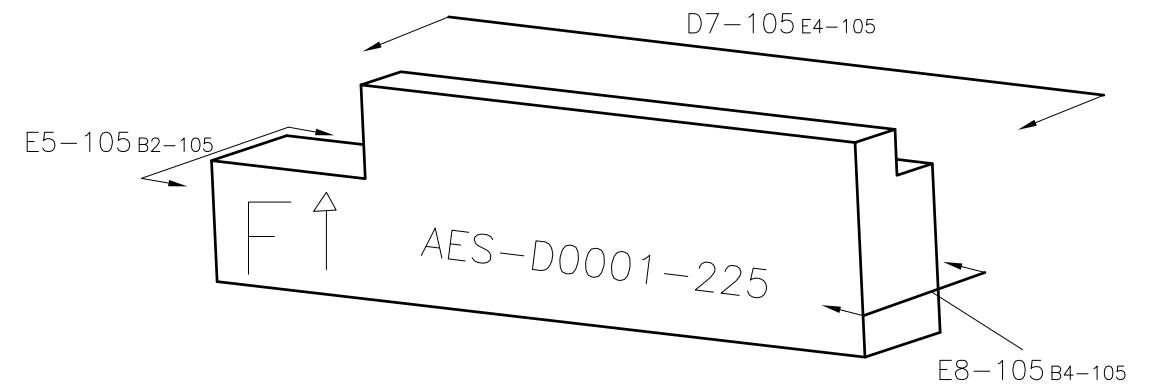

— 225

NOTE: ALL VIEWS TAKEN AS TRUE VIEWS PARALLEL TO SURFACE OF PART

	DRAWING NUMBER				AES-D0001
	SIZE	SCALE	SHEET	OF	
A3	NONE	105	124	E	

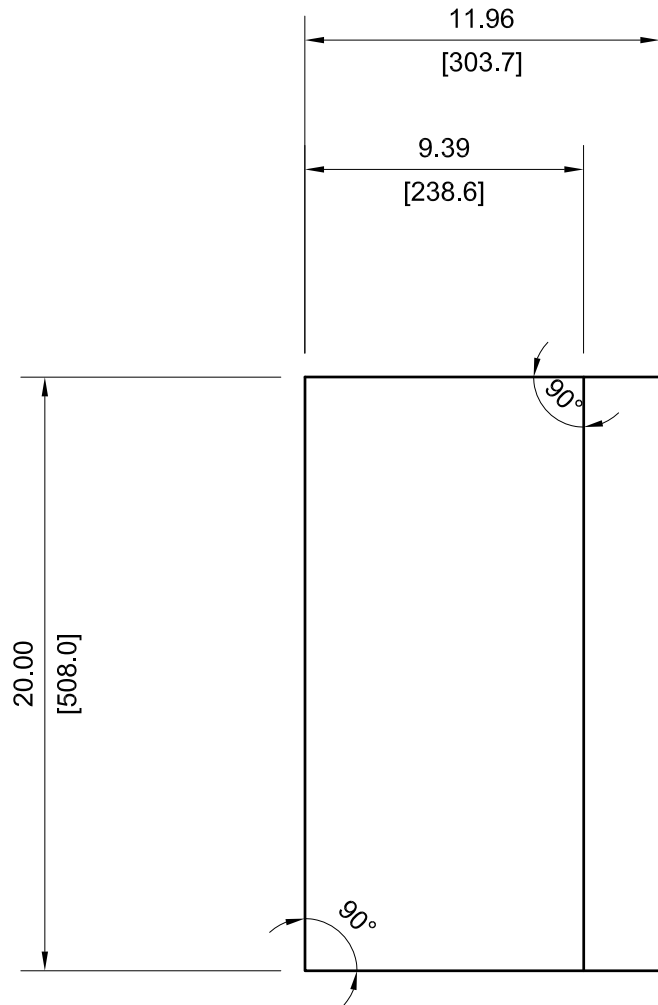

VIEW C7-106

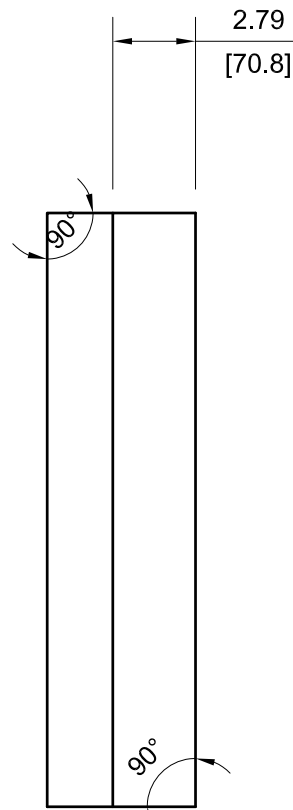

VIEW E6-106

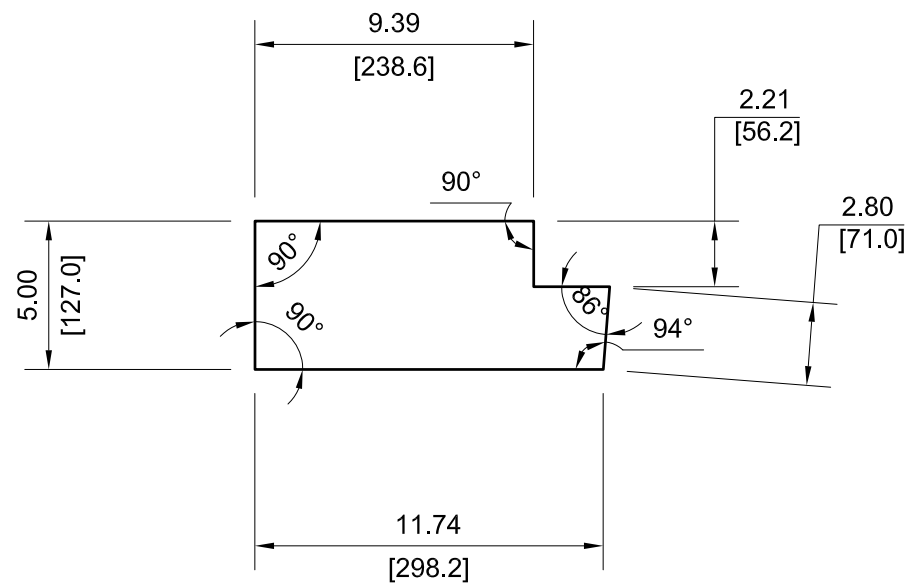

VIEW D8-106

— 227

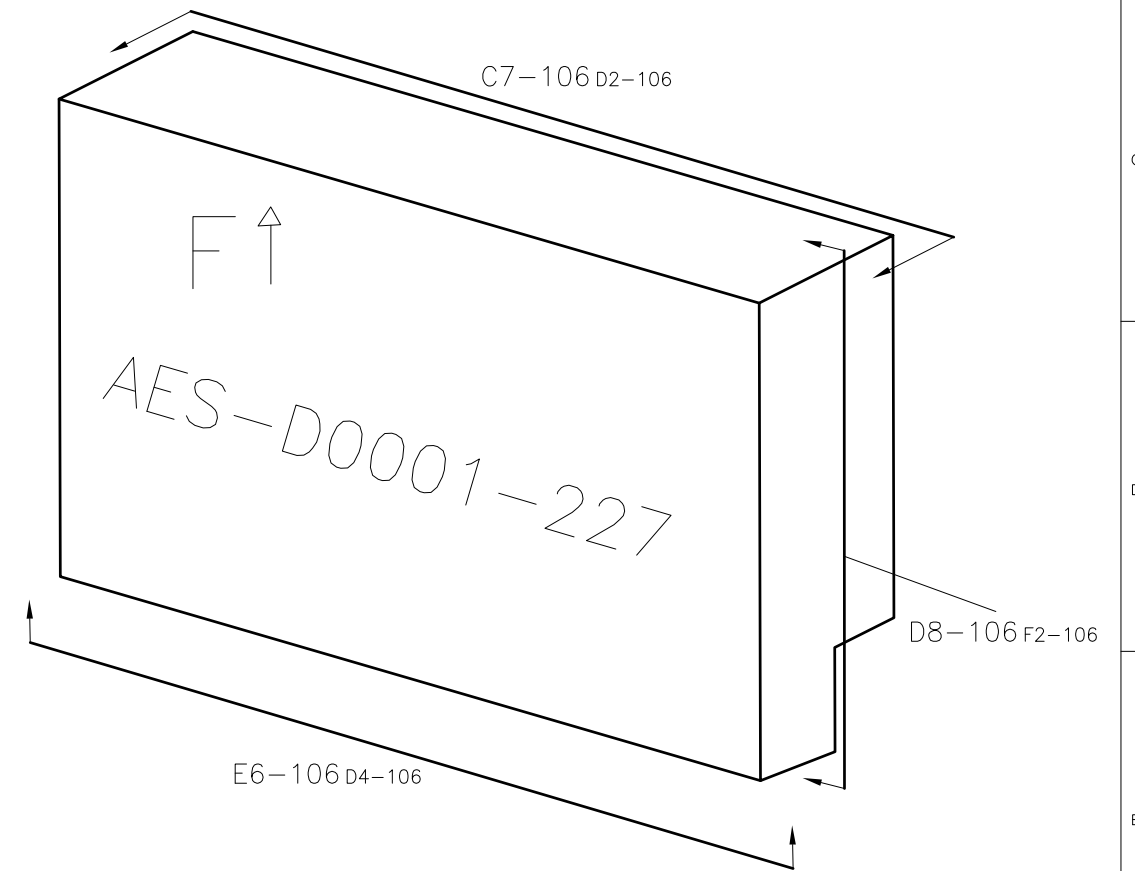

NOTE: ALL VIEWS TAKEN AS TRUE VIEWS PARALLEL TO SURFACE OF PART

		DRAWING NUMBER			
		AES-D0001			
SIZE	SCALE	SHEET	OF	REVISION	
A3	NONE	106	124	E	

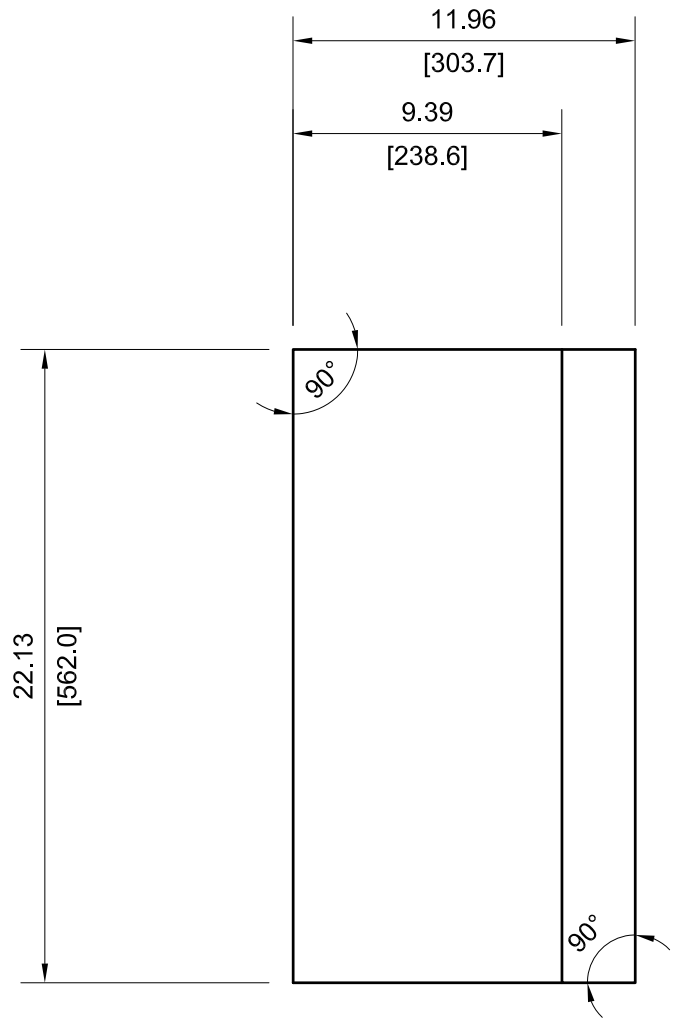

VIEW C7-107

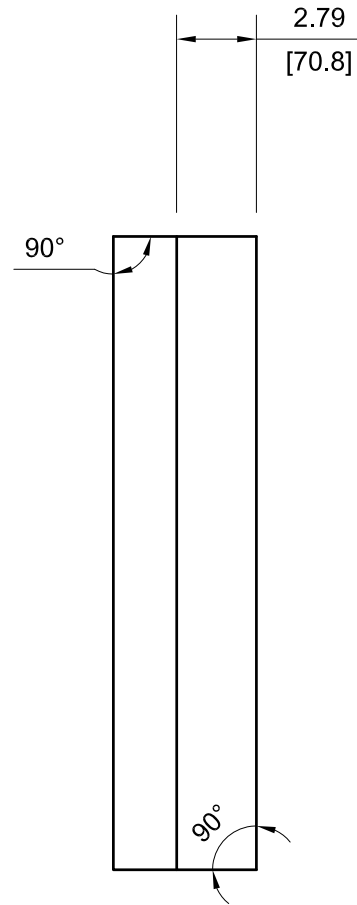

VIEW E6-107

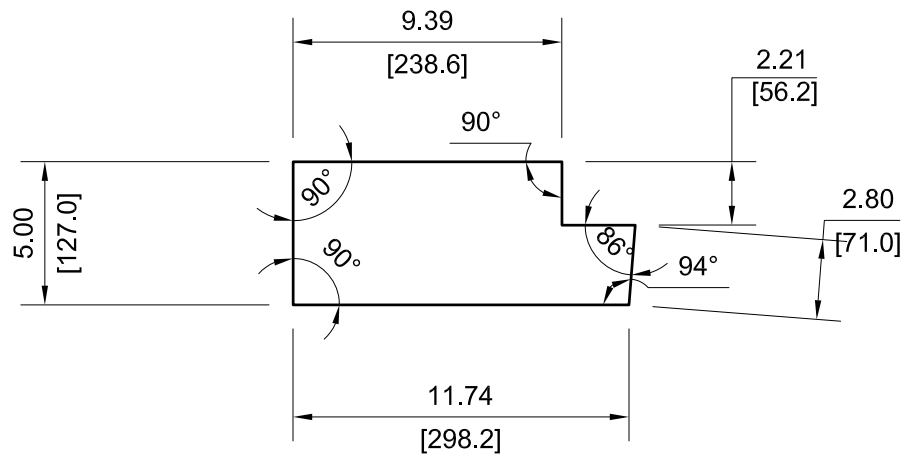

VIEW D8-107

— 229

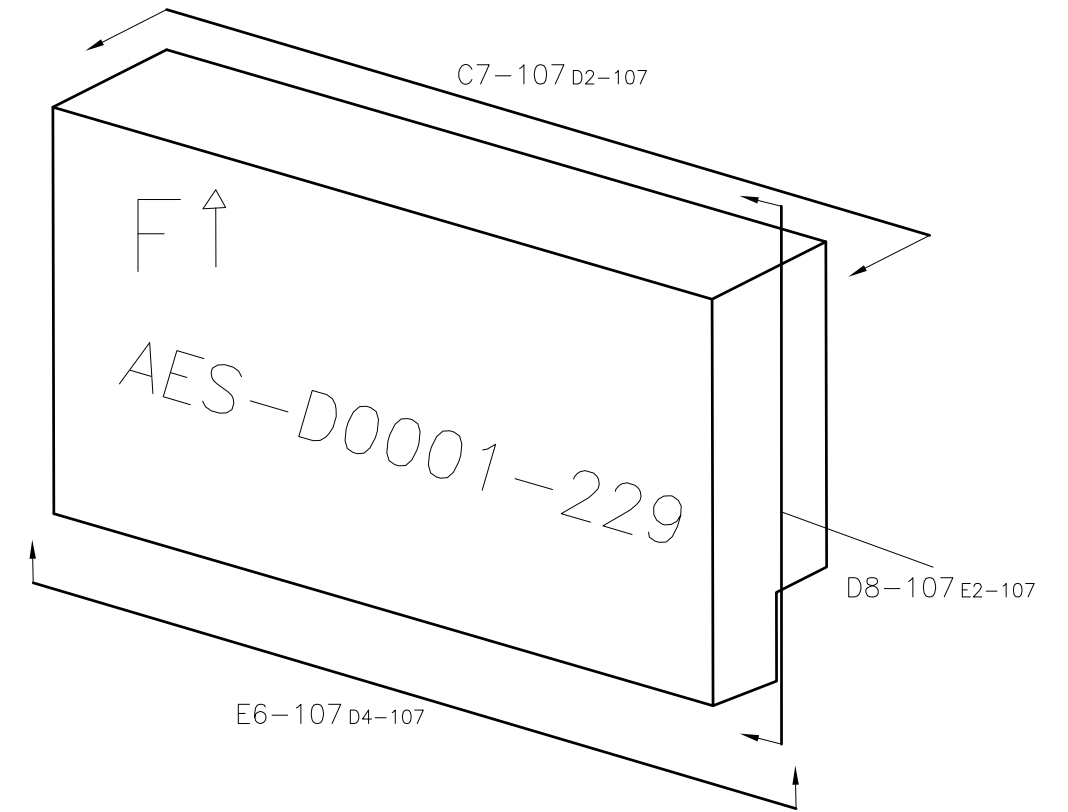

NOTE: ALL VIEWS TAKEN AS TRUE VIEWS PARALLEL TO SURFACE OF PART

		DRAWING NUMBER			
		AES-D0001			
SIZE	SCALE	SHEET	OF	REVISION	
A3	NONE	107	124	E	

- 231

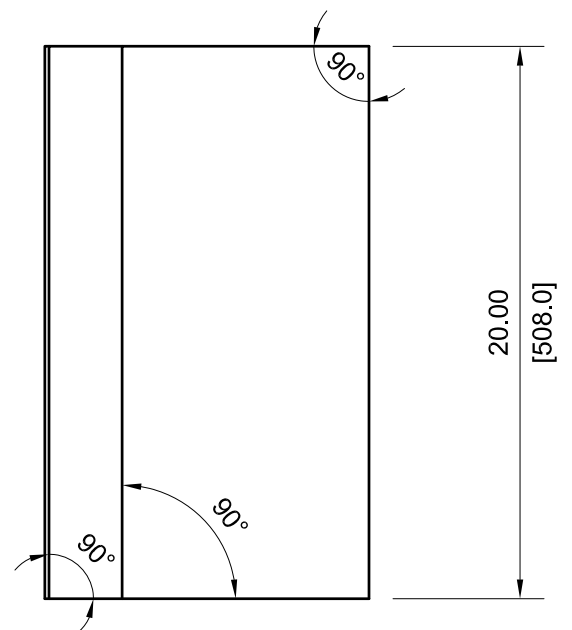

VIEW E6-108

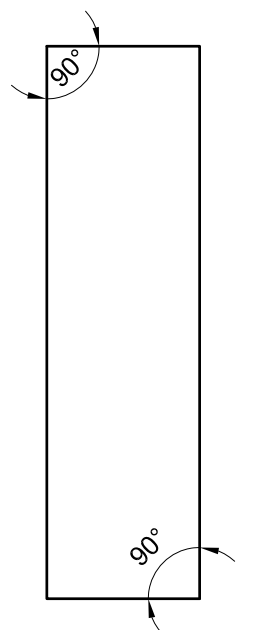

VIEW C7-108

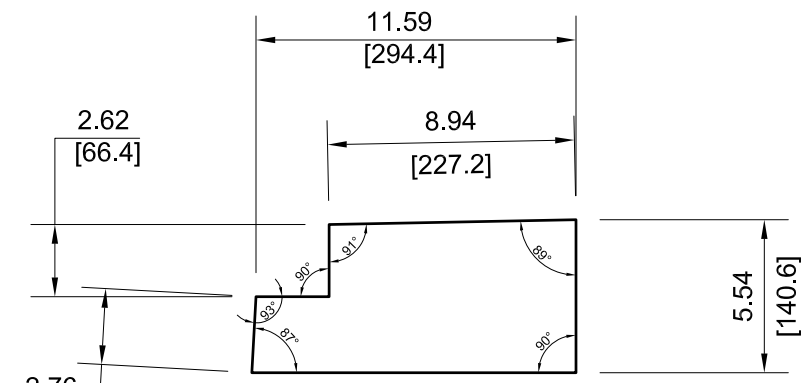
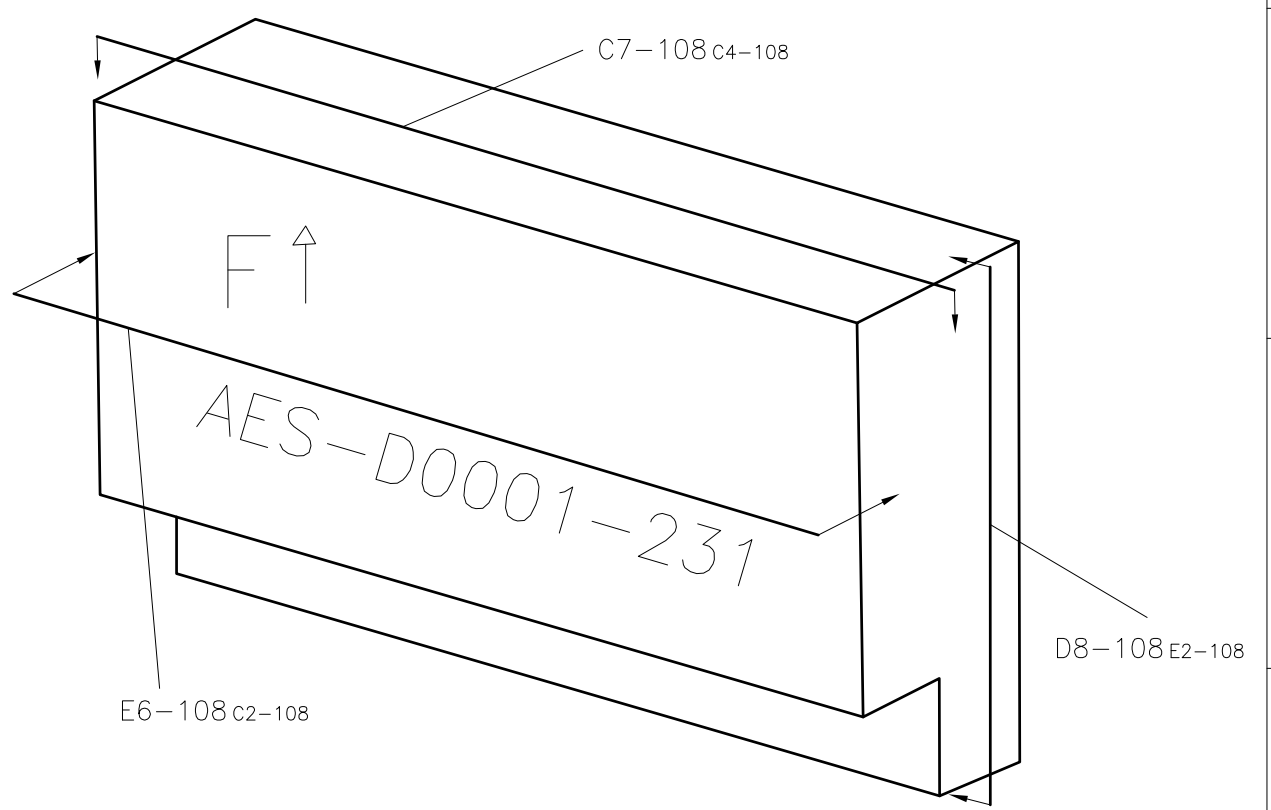

VIEW D8-108

NOTE: ALL VIEWS TAKEN AS TRUE VIEWS PARALLEL TO SURFACE OF PART



DRAWING NUMBER					AES-D0001	
SIZE	SCALE	SHEET	OF	REVISION		
A3	NONE	108	124	E		

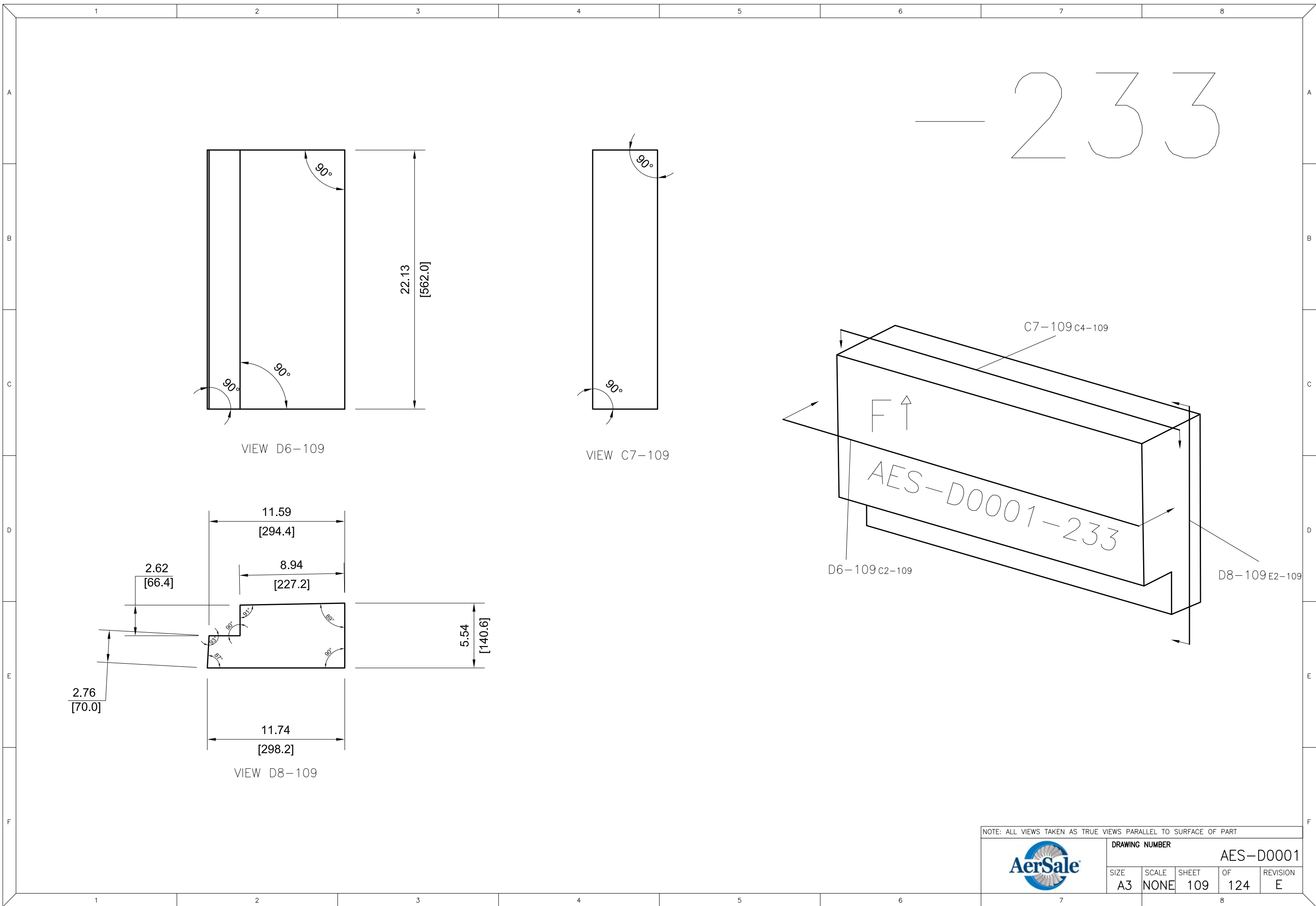

— 233

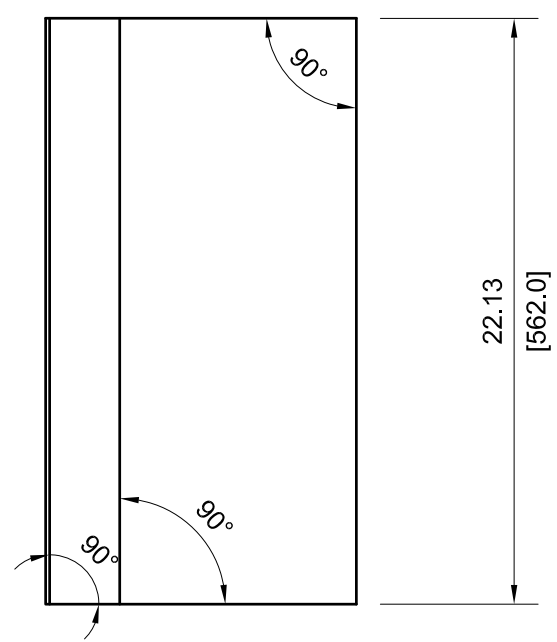

VIEW D6-109

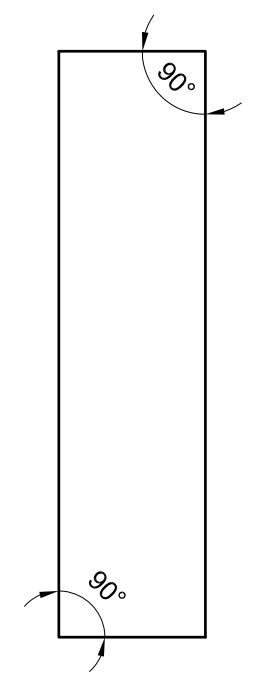

VIEW C7-109

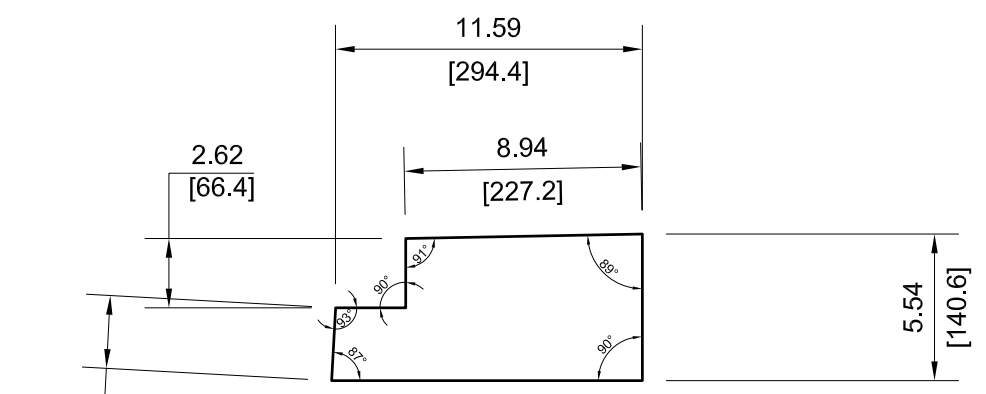

VIEW D8-109

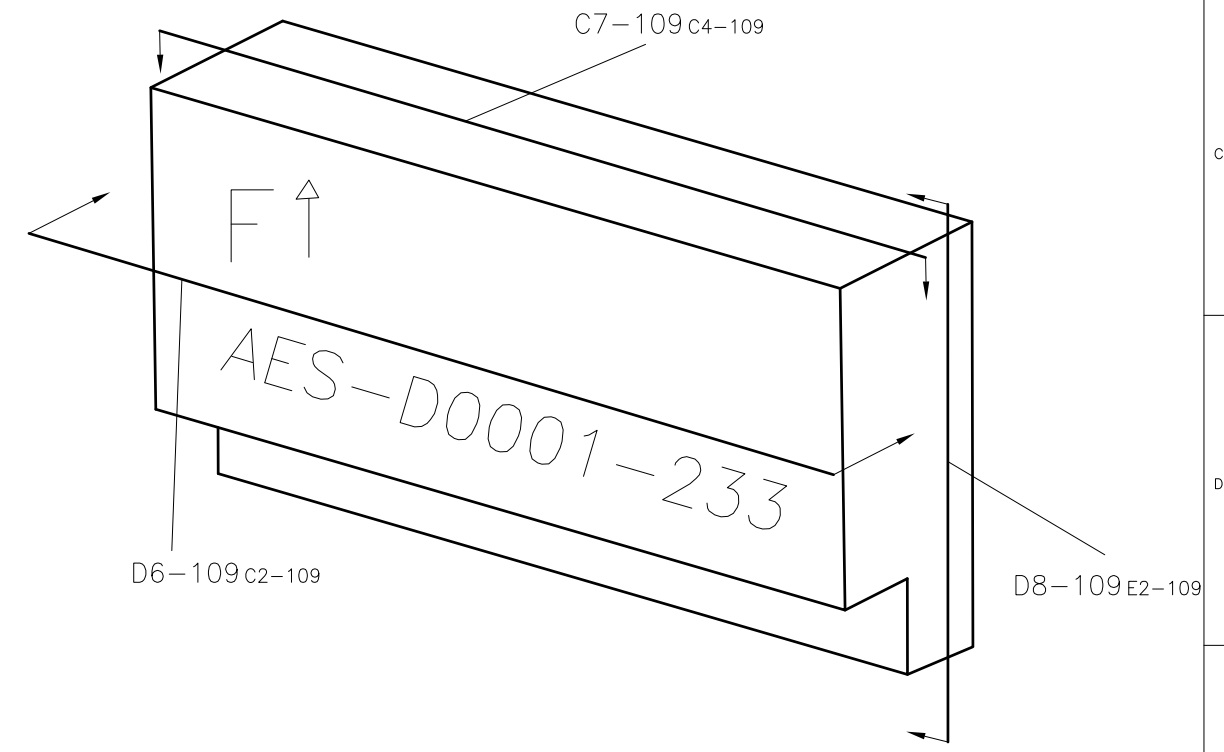

NOTE: ALL VIEWS TAKEN AS TRUE VIEWS PARALLEL TO SURFACE OF PART

	DRAWING NUMBER				AES-D0001
	SIZE	SCALE	SHEET	OF	REVISION
A3	NONE	109	124	E	

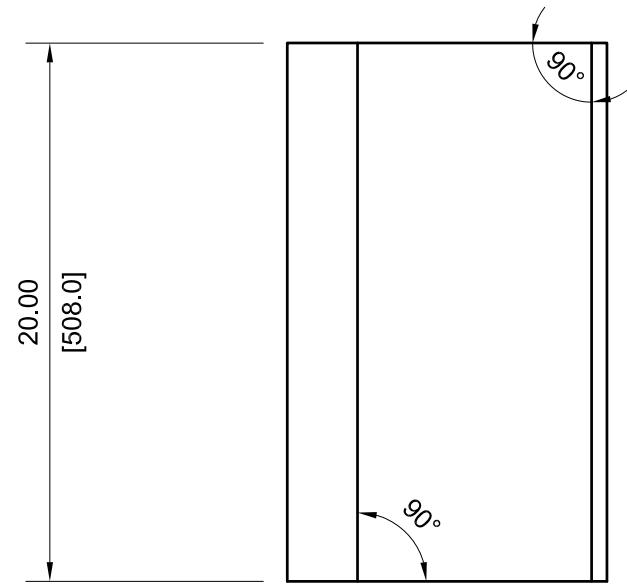

VIEW D6-110

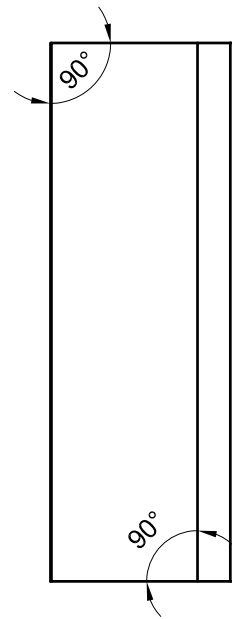

VIEW C7-110

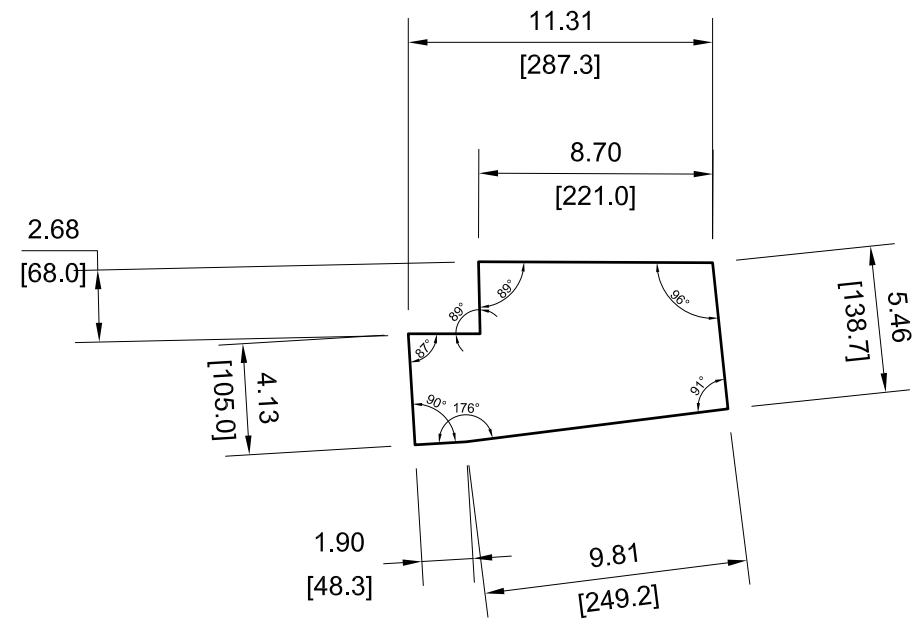

VIEW D8-110

— 235

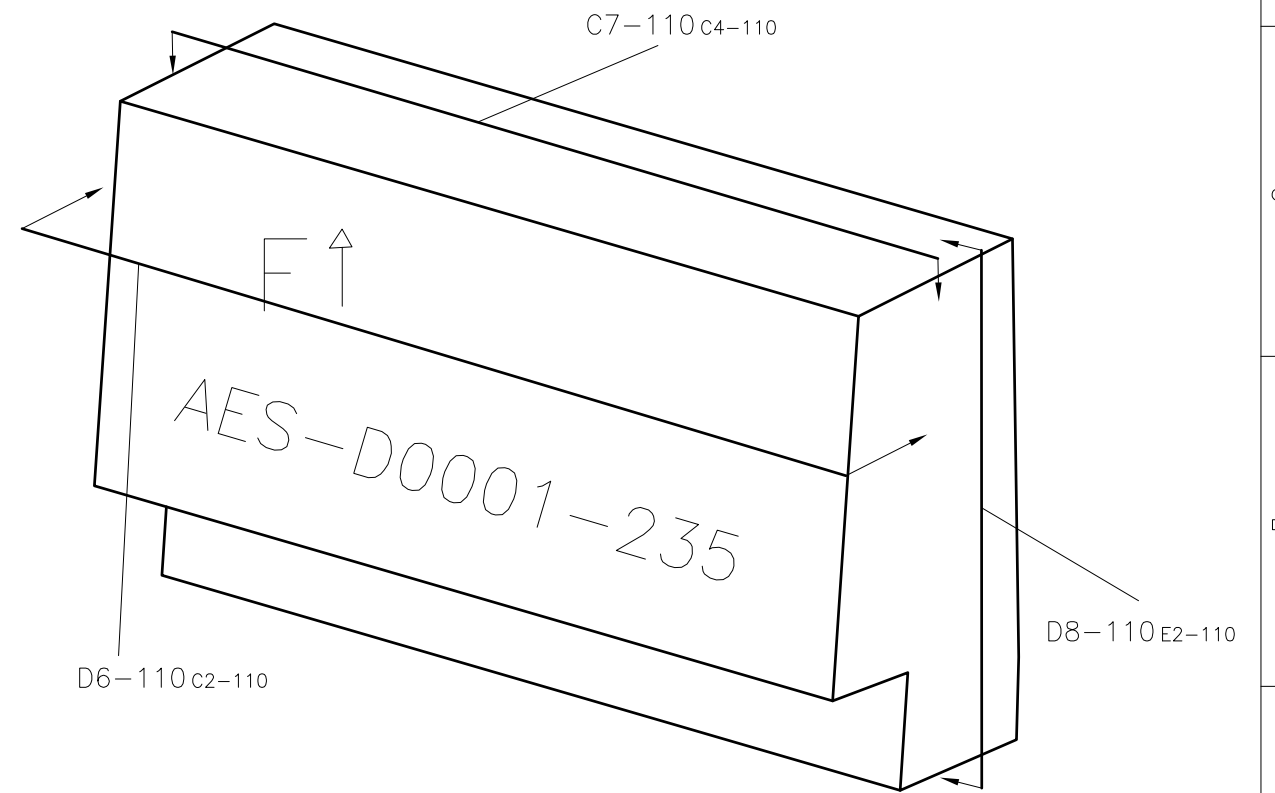

NOTE: ALL VIEWS TAKEN AS TRUE VIEWS PARALLEL TO SURFACE OF PART

	DRAWING NUMBER				AES-D0001
	SIZE	SCALE	SHEET	OF	REVISION
A3	NONE	110	124	E	

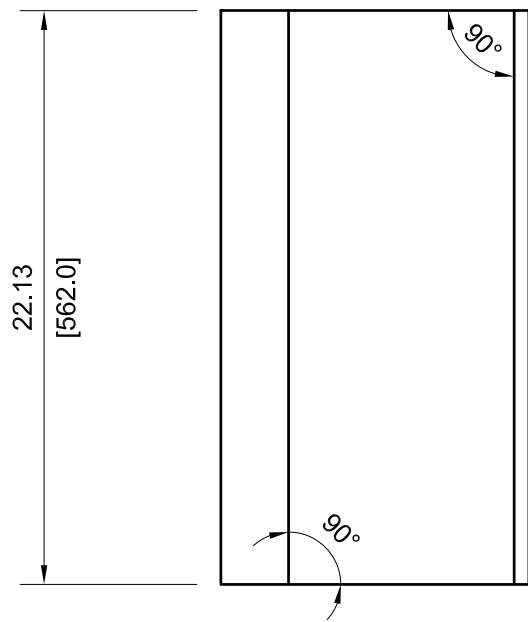

VIEW D6-111

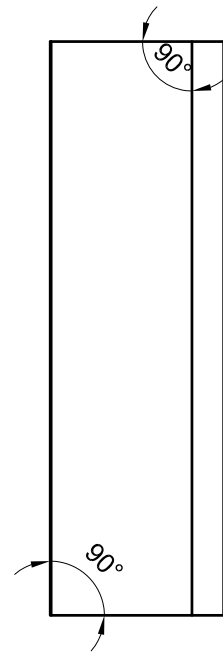

VIEW C7-111

- 237

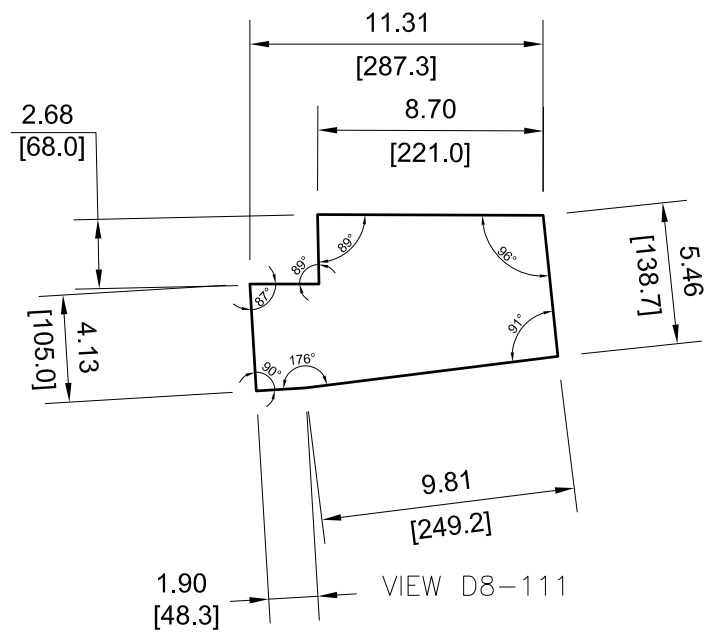
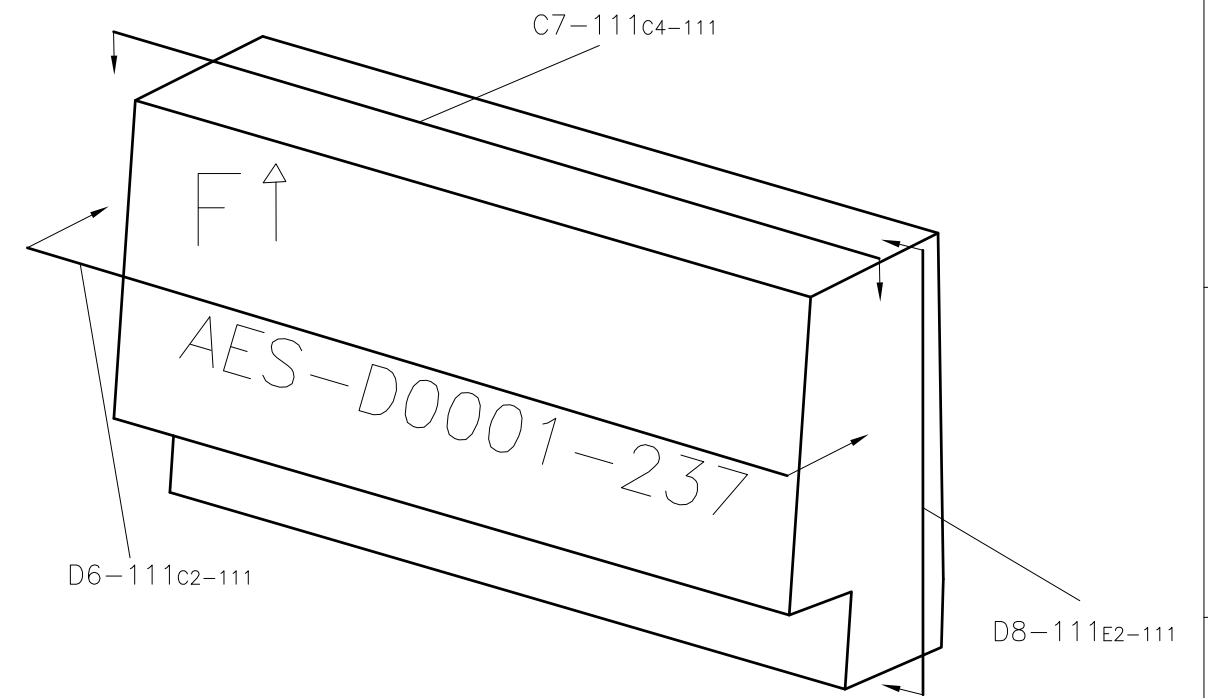

VIEW D8-111

NOTE: ALL VIEWS TAKEN AS TRUE VIEWS PARALLEL TO SURFACE OF PART



DRAWING NUMBER					AES-D0001	
SIZE	SCALE	SHEET	OF	REVISION		
A3	NONE	111	124	E		

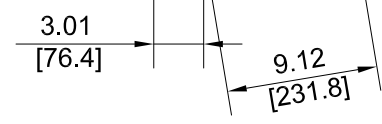
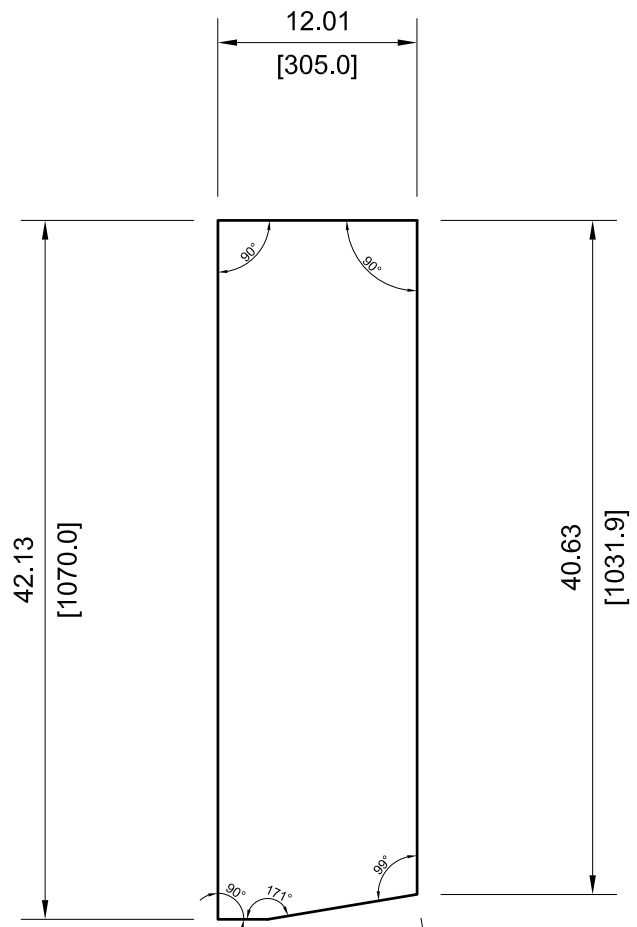

VIEW D7-112

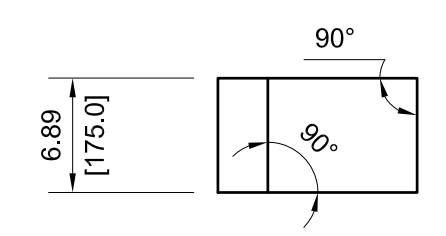

VIEW D8-112

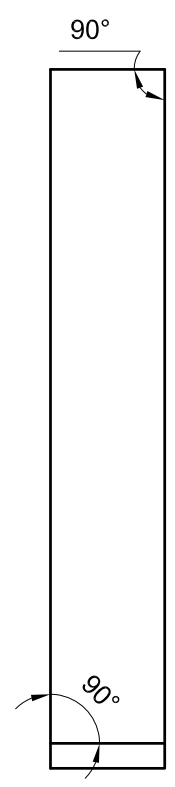

VIEW C7-112

— 239

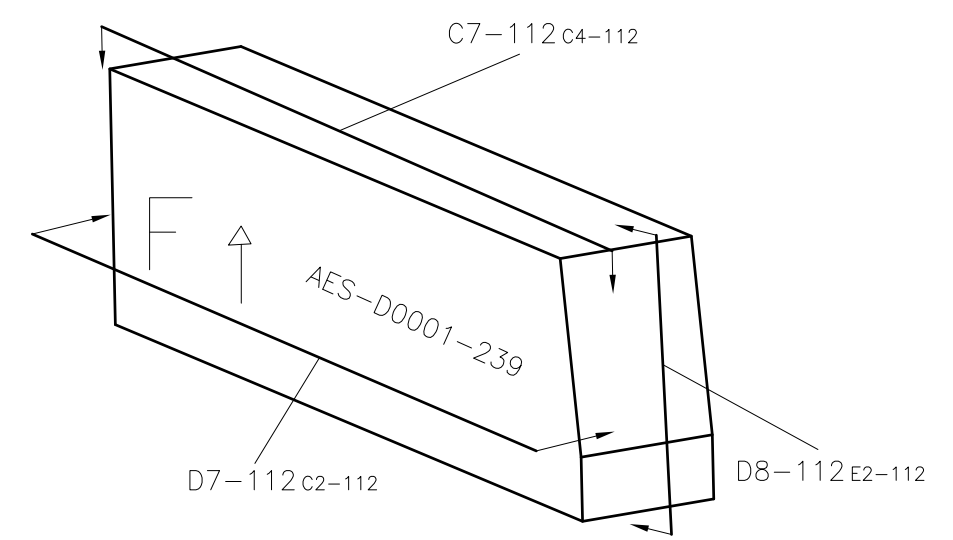

NOTE: ALL VIEWS TAKEN AS TRUE VIEWS PARALLEL TO SURFACE OF PART

	DRAWING NUMBER				AES-D0001
	SIZE	SCALE	SHEET	OF	REVISION
A3	NONE	112	124	E	

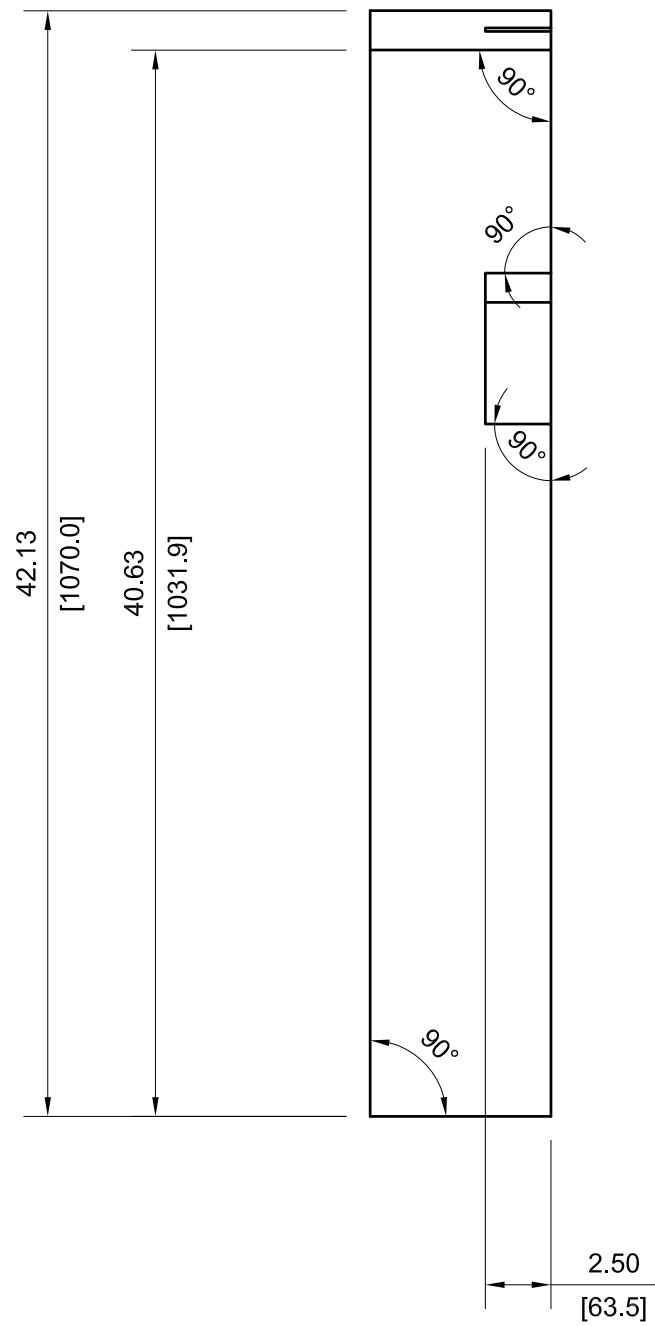

VIEW C5-113

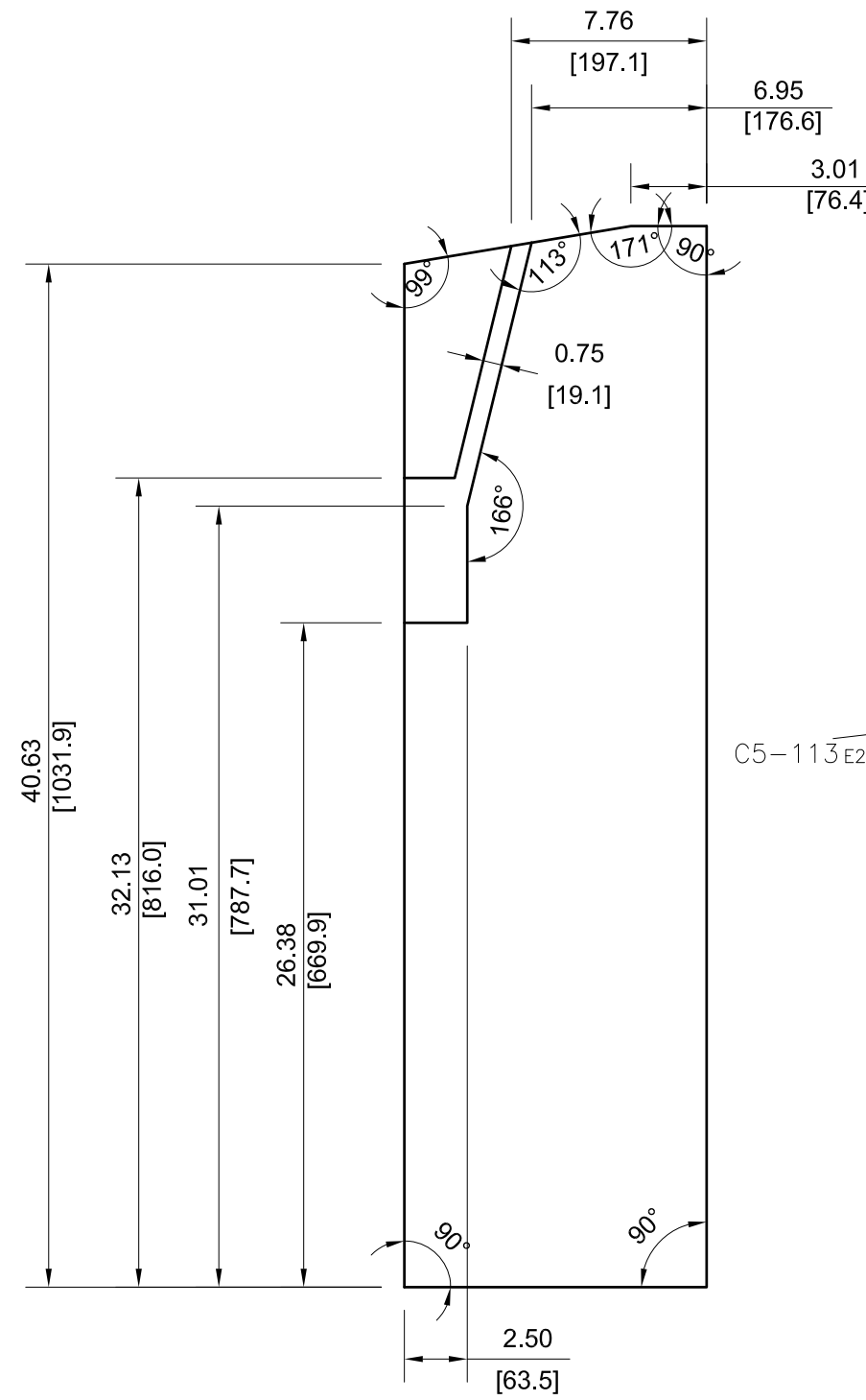

VIEW C7-113

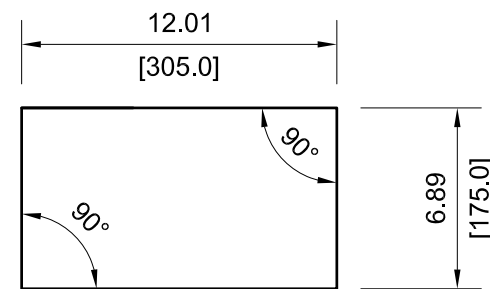

VIEW D8-113

— 241

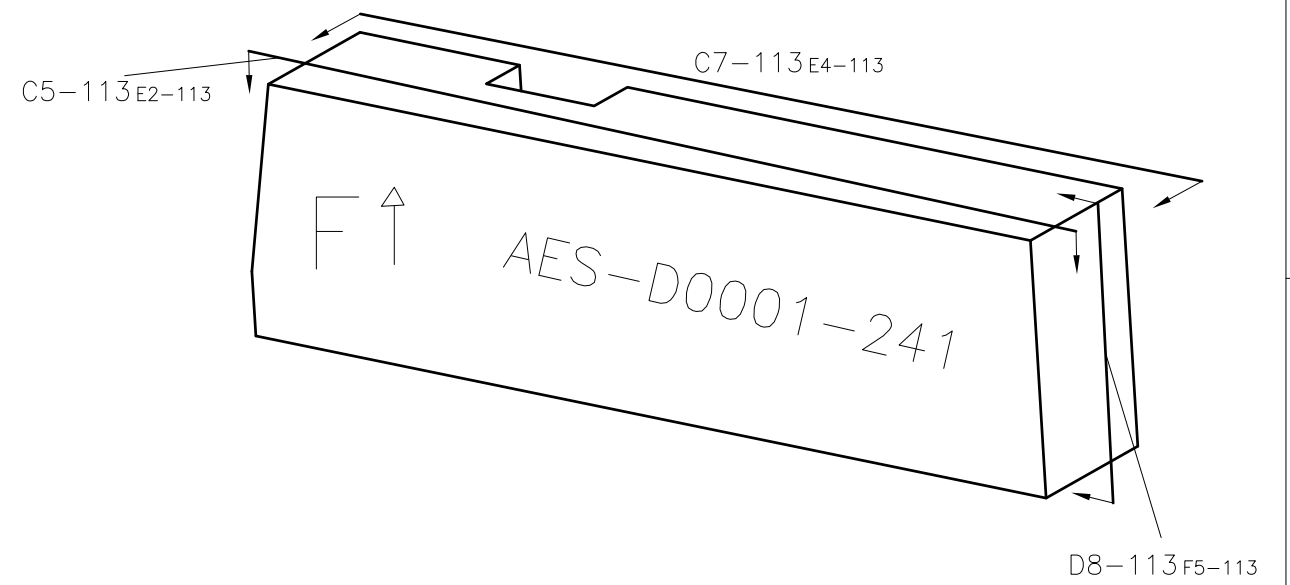

NOTE: ALL VIEWS TAKEN AS TRUE VIEWS PARALLEL TO SURFACE OF PART

		DRAWING NUMBER			
		AES-D0001			
SIZE	SCALE	SHEET	OF	REVISION	
A3	NONE	113	124	E	

- 243

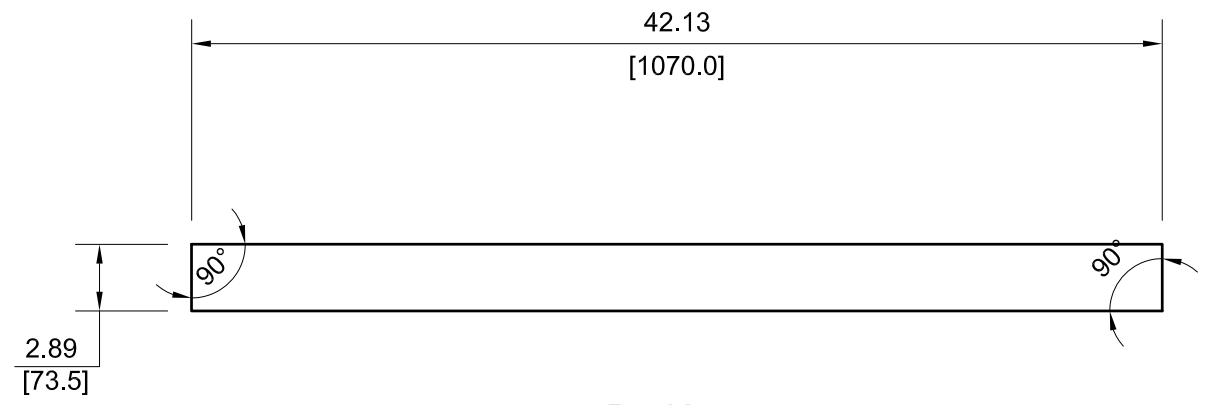

VIEW C8-114

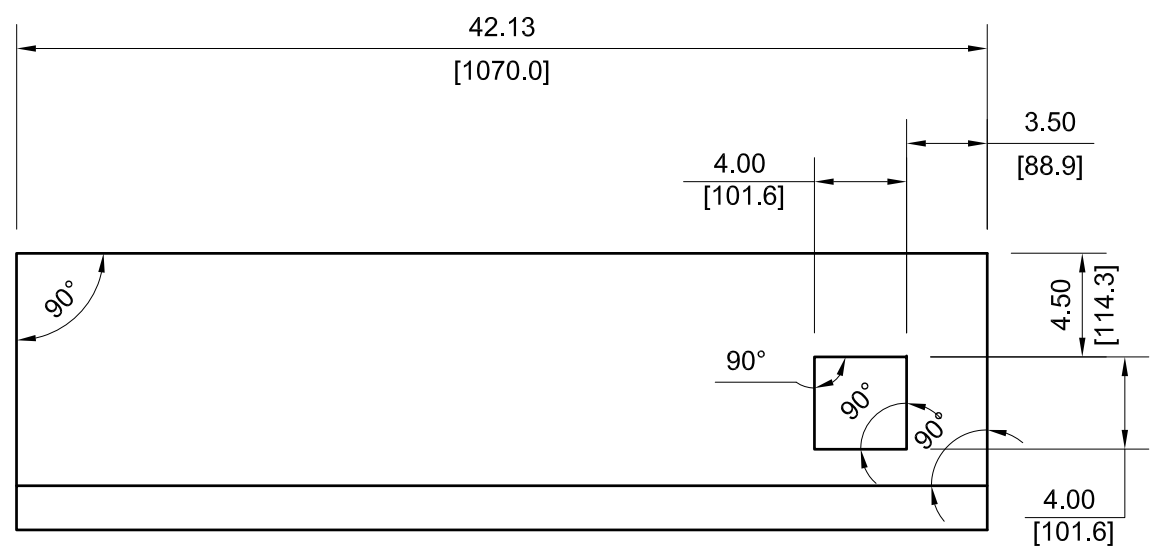
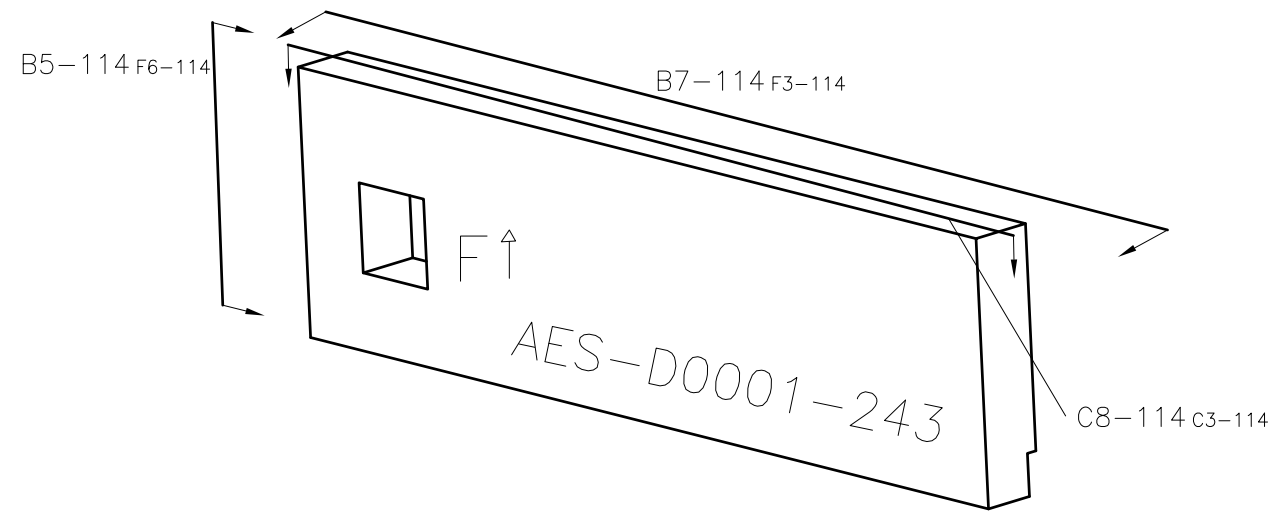

VIEW B7-114

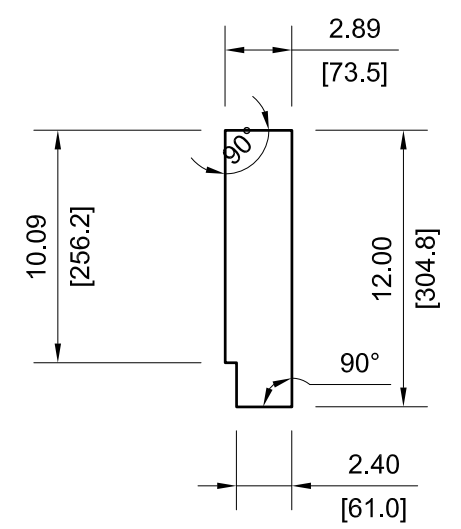

VIEW B5-114

NOTE: ALL VIEWS TAKEN AS TRUE VIEWS PARALLEL TO SURFACE OF PART

		DRAWING NUMBER			
		AES-D0001			
SIZE	SCALE	SHEET	OF	REVISION	
A3	NONE	114	124	E	

- 245

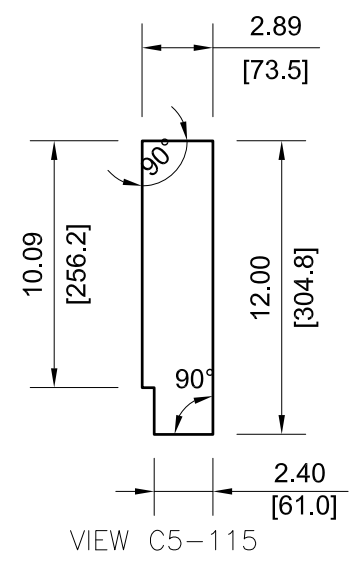
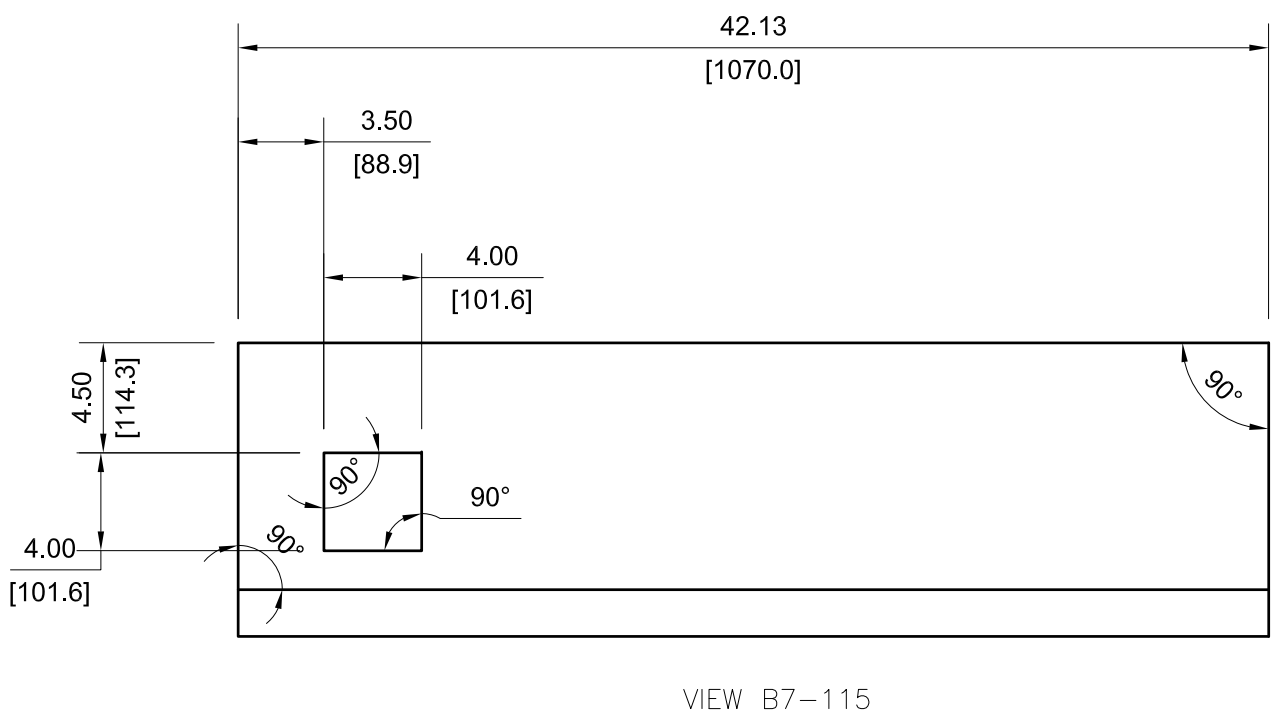
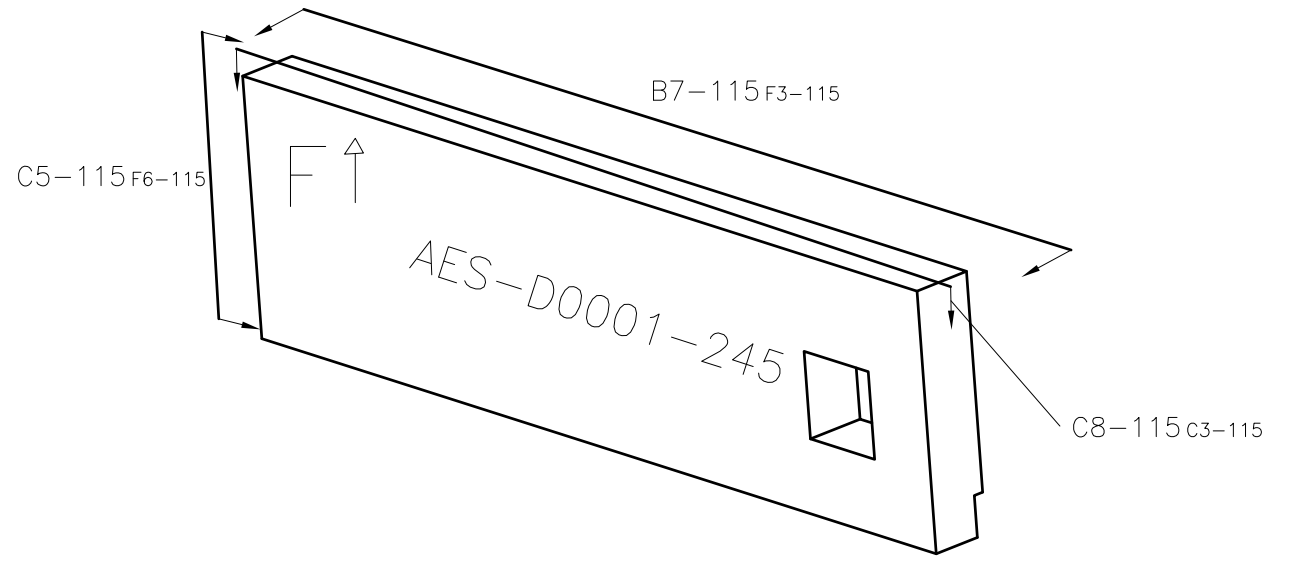
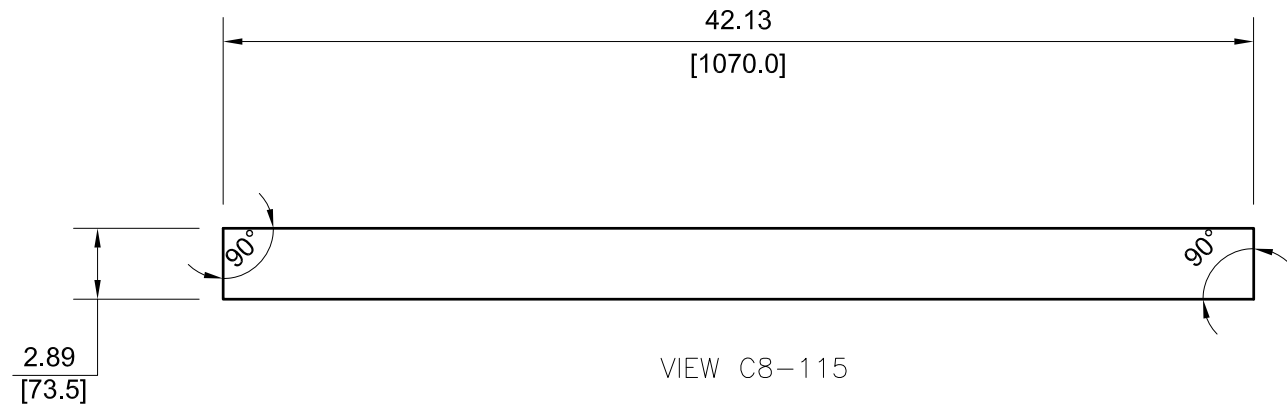

NOTE: ALL VIEWS TAKEN AS TRUE VIEWS PARALLEL TO SURFACE OF PART

	DRAWING NUMBER				
	AES-D0001				
SIZE	SCALE	SHEET	OF	REVISION	
A3	NONE	115	124	E	

— 247

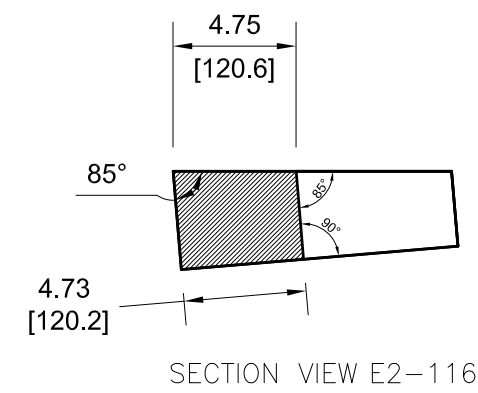
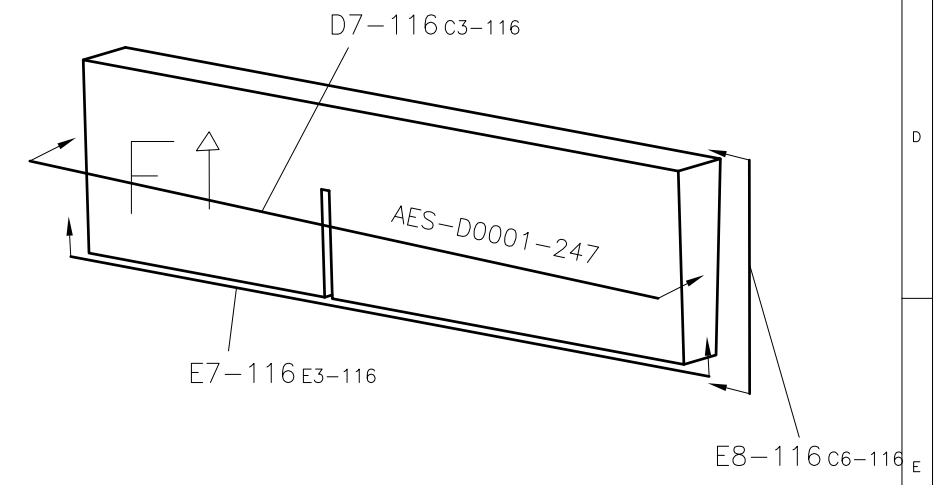
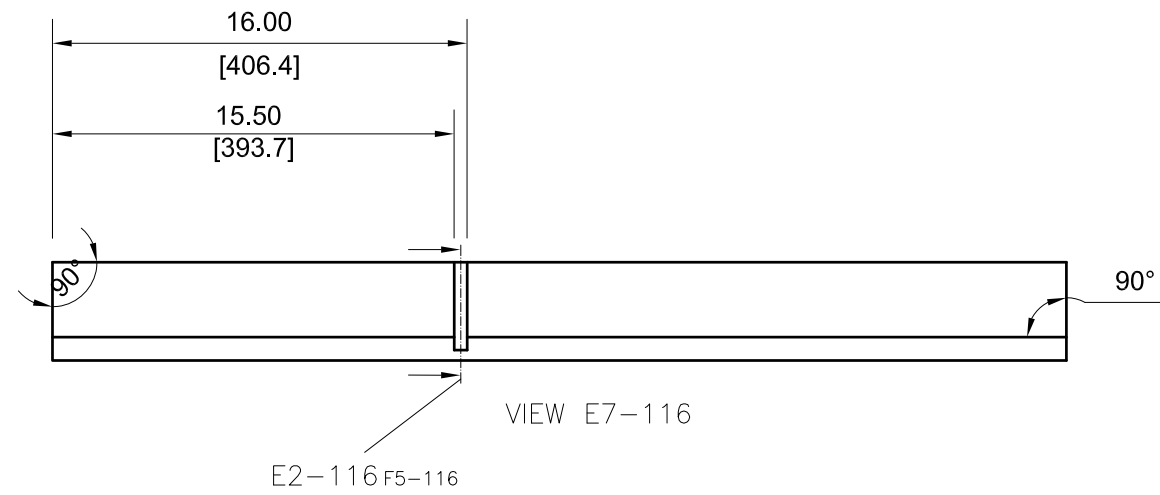
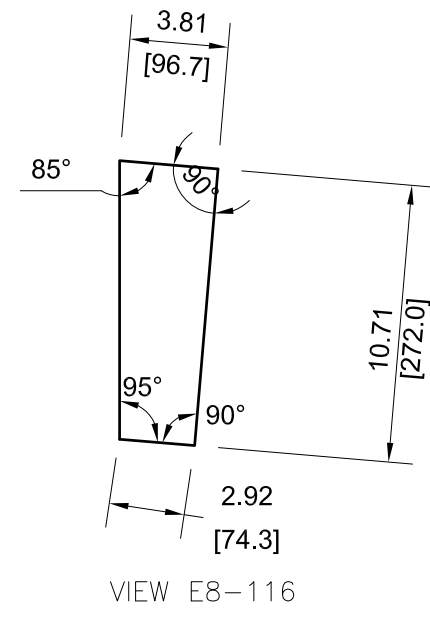
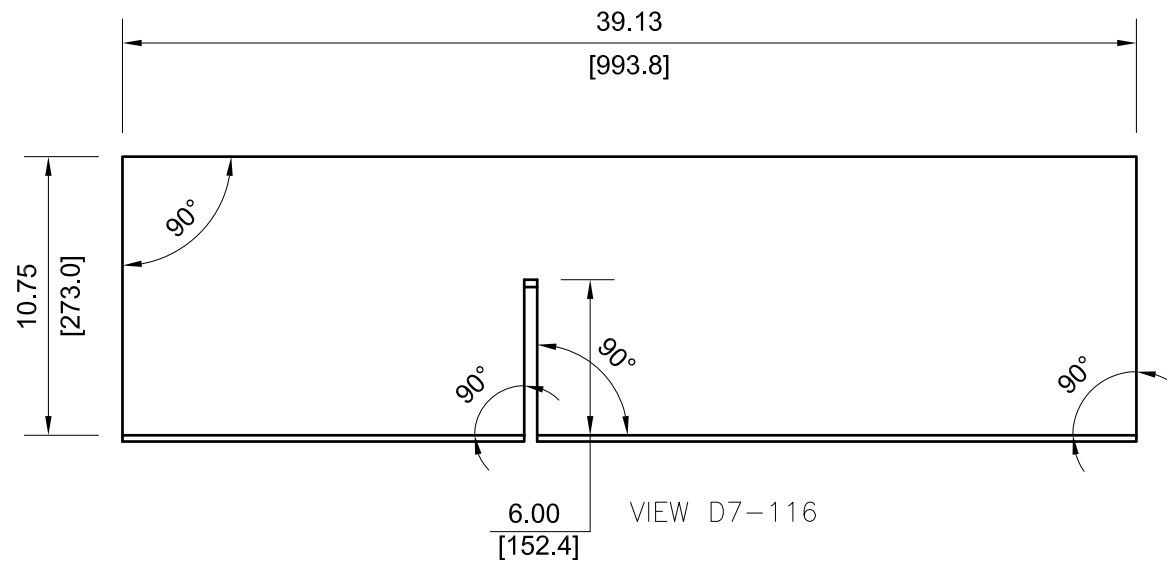

NOTE: ALL VIEWS TAKEN AS TRUE VIEWS PARALLEL TO SURFACE OF PART

	DRAWING NUMBER			
	AES-D0001			
SIZE	SCALE	SHEET	OF	REVISION
A3	NONE	116	124	E

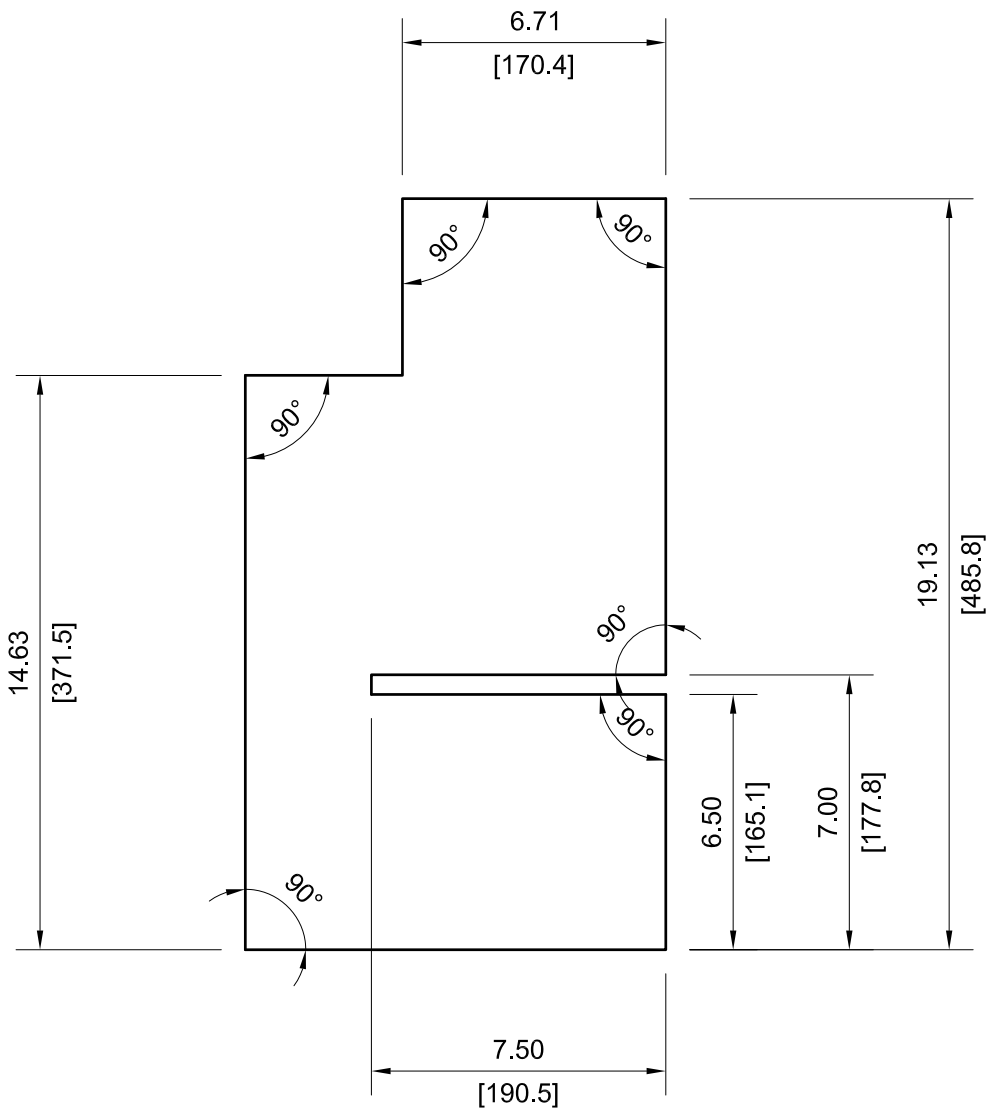

VIEW D7-117

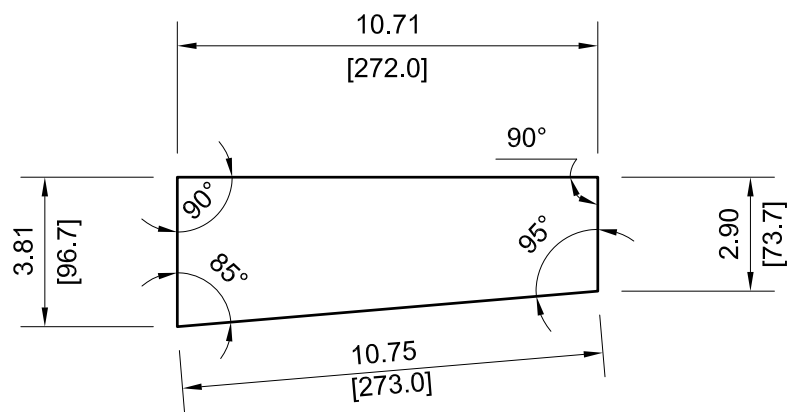

VIEW D6-117

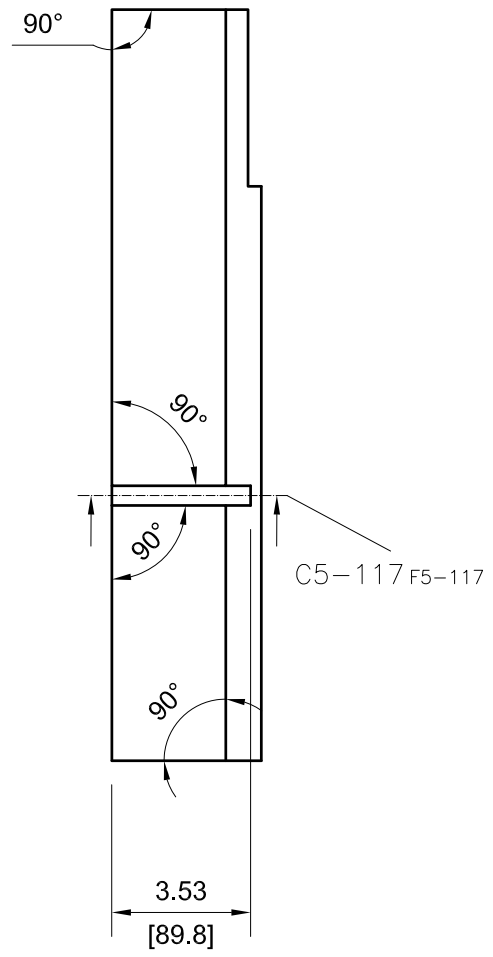

VIEW E7-117

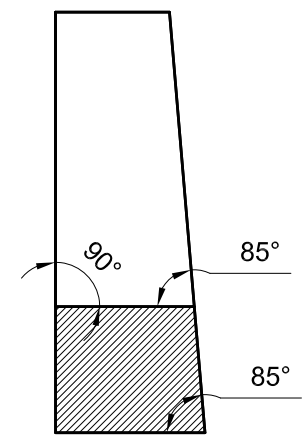

SECTION VIEW C5-117

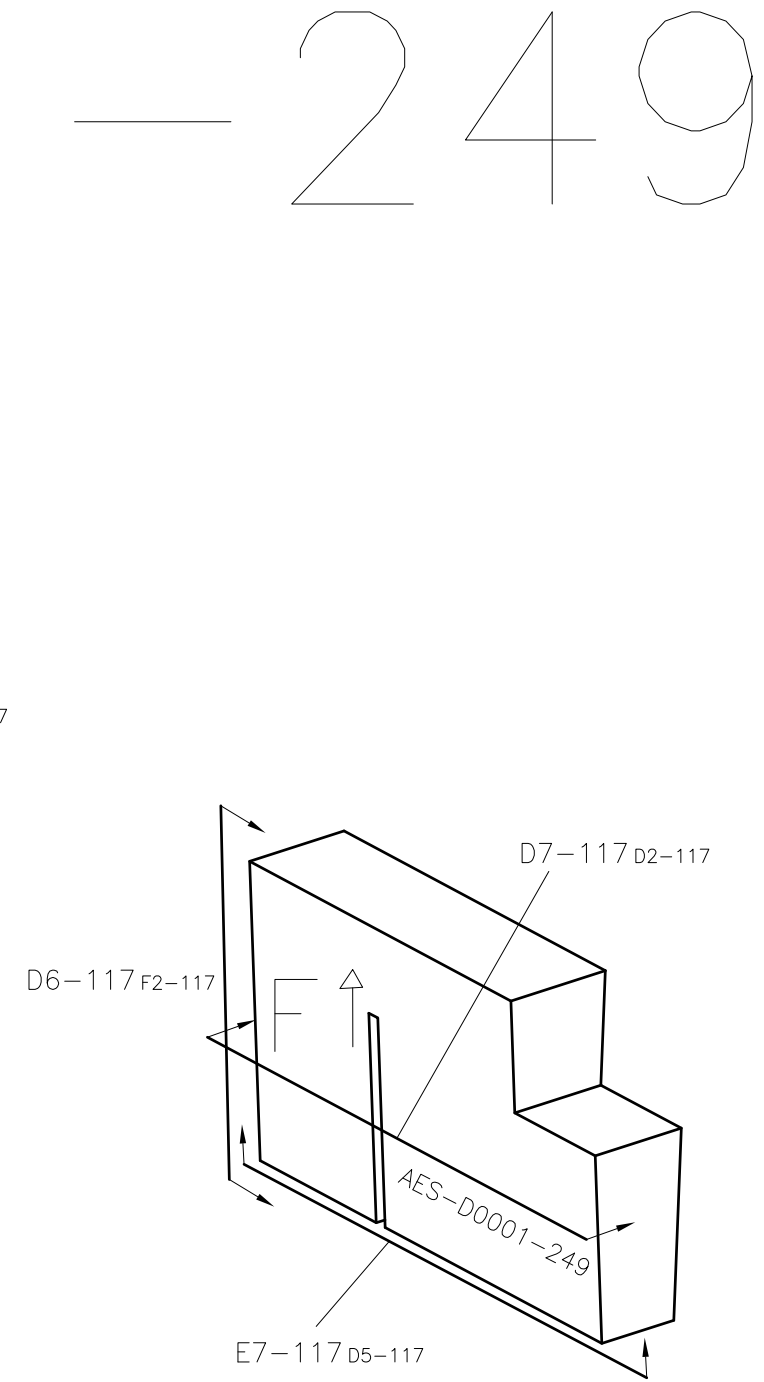

NOTE: ALL VIEWS TAKEN AS TRUE VIEWS PARALLEL TO SURFACE OF PART

		DRAWING NUMBER			
		AES-D0001			
SIZE	SCALE	SHEET	OF	REVISION	
A3	NONE	117	124	E	

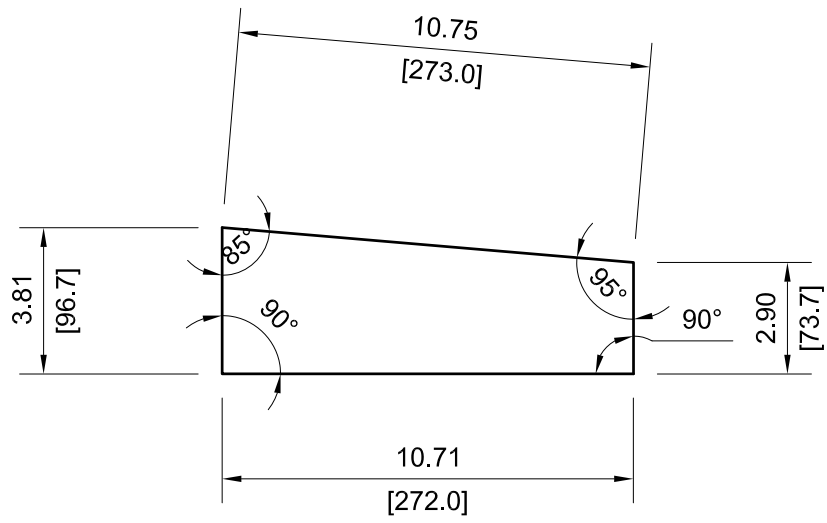

VIEW E8-118

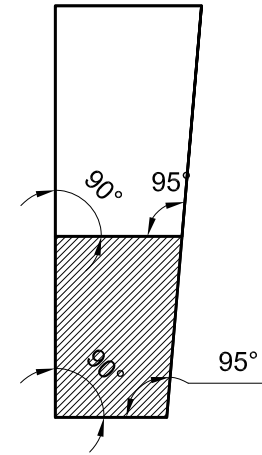

SECTION VIEW E5-118

— 251

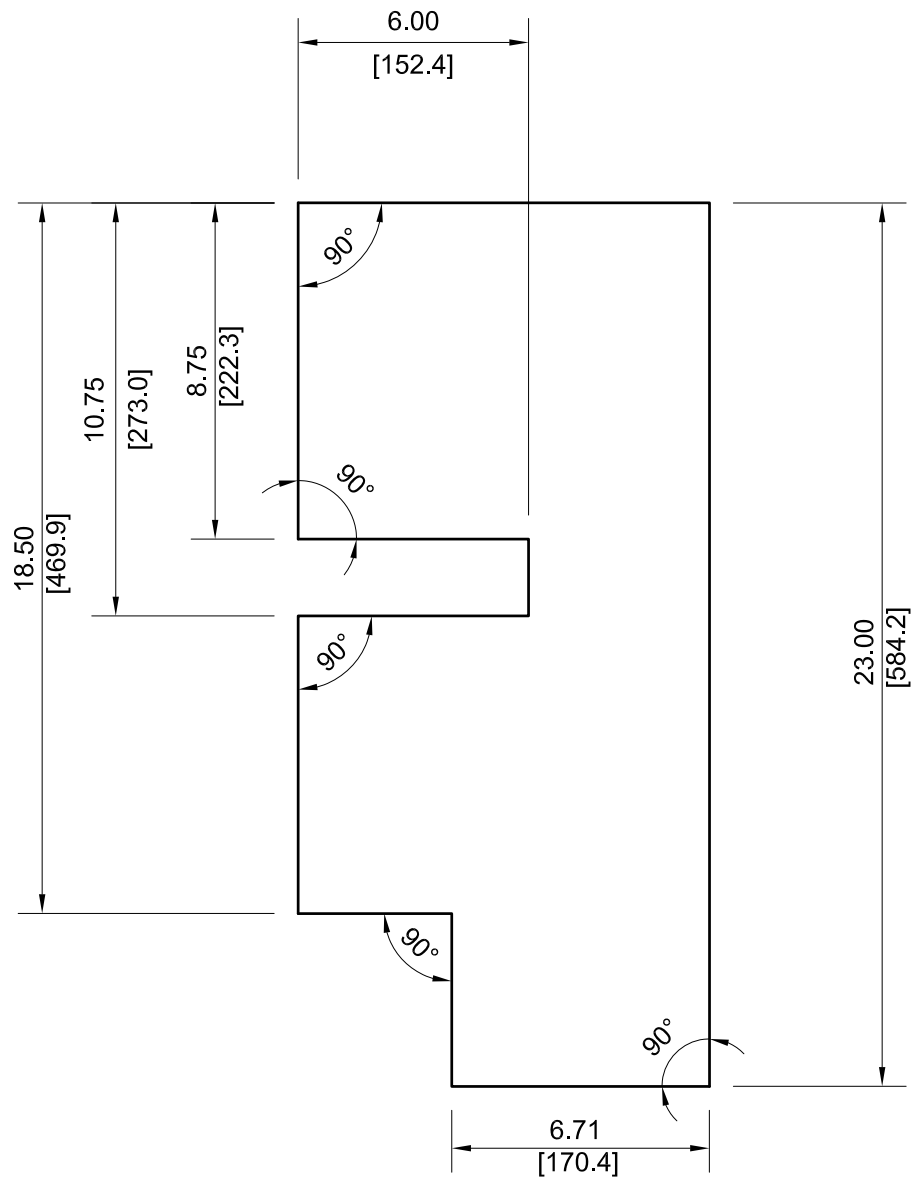

VIEW C7-118

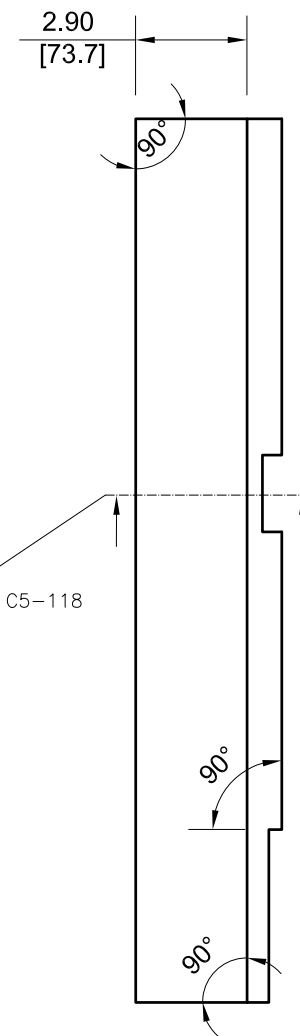

VIEW E7-118

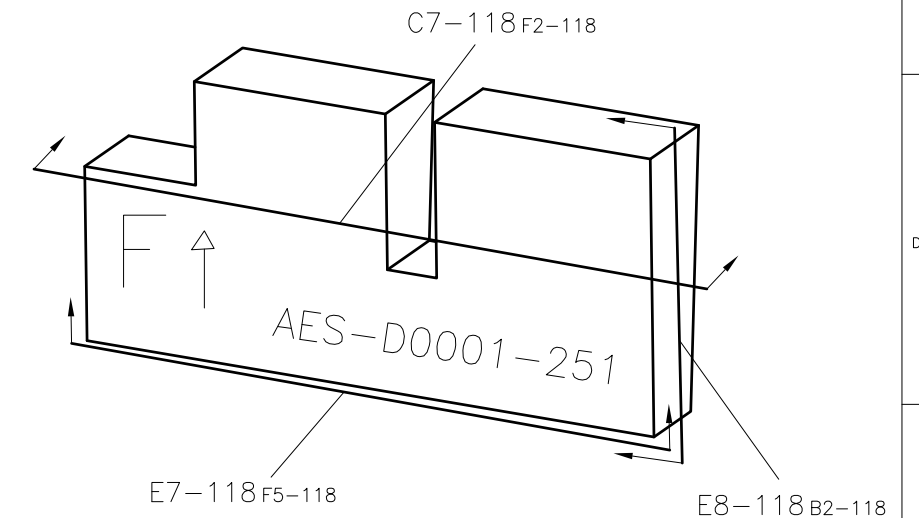

NOTE: ALL VIEWS TAKEN AS TRUE VIEWS PARALLEL TO SURFACE OF PART

	DRAWING NUMBER				
	AES-D0001				
SIZE	SCALE	SHEET	OF	REVISION	
A3	NONE	118	124	E	

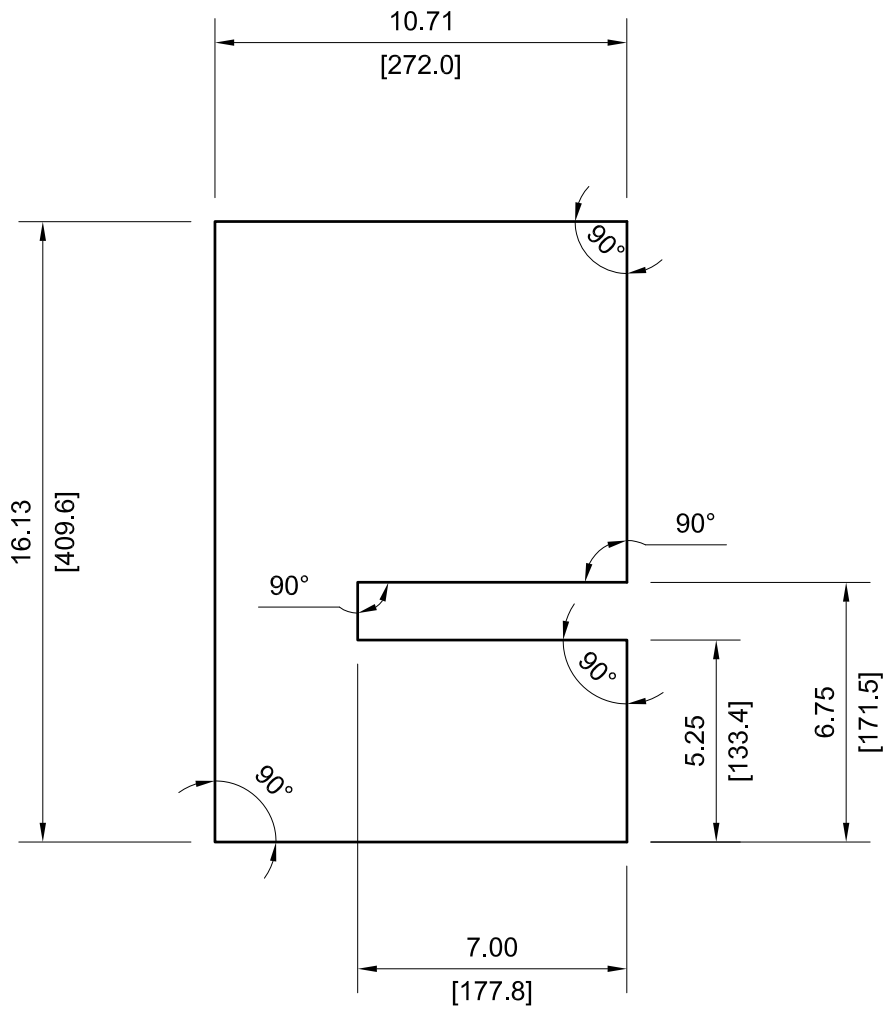

VIEW C8-119

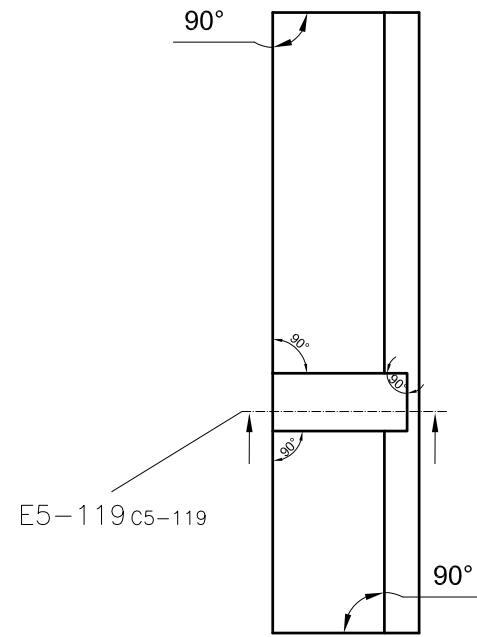

VIEW E6-119

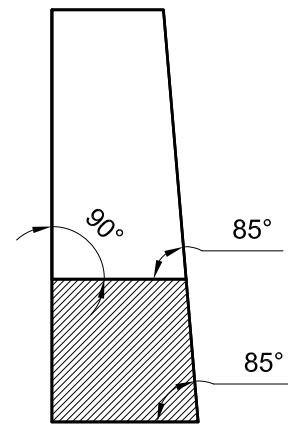

SECTION VIEW E5-119

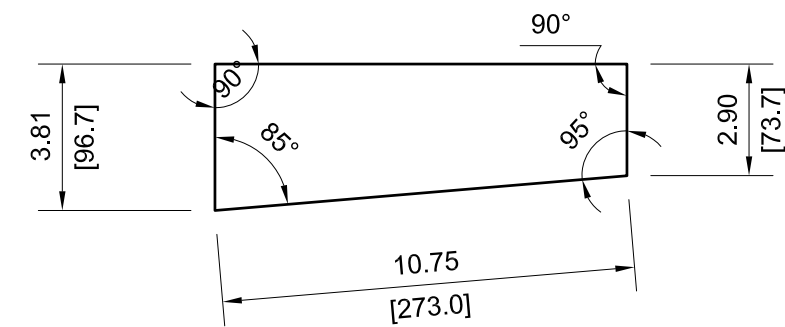

VIEW D6-119

— 253

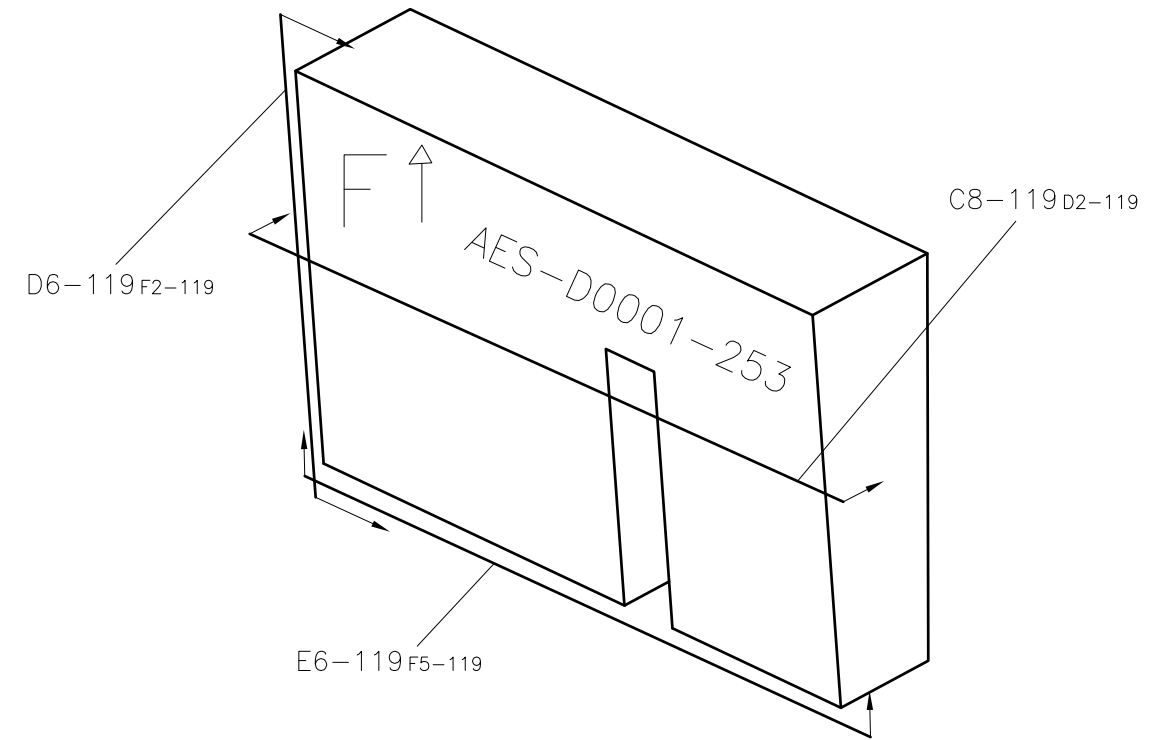

NOTE: ALL VIEWS TAKEN AS TRUE VIEWS PARALLEL TO SURFACE OF PART



DRAWING NUMBER					AES-D0001				
SIZE	SCALE	SHEET	OF	REVISION					
A3	NONE	119	124	E					

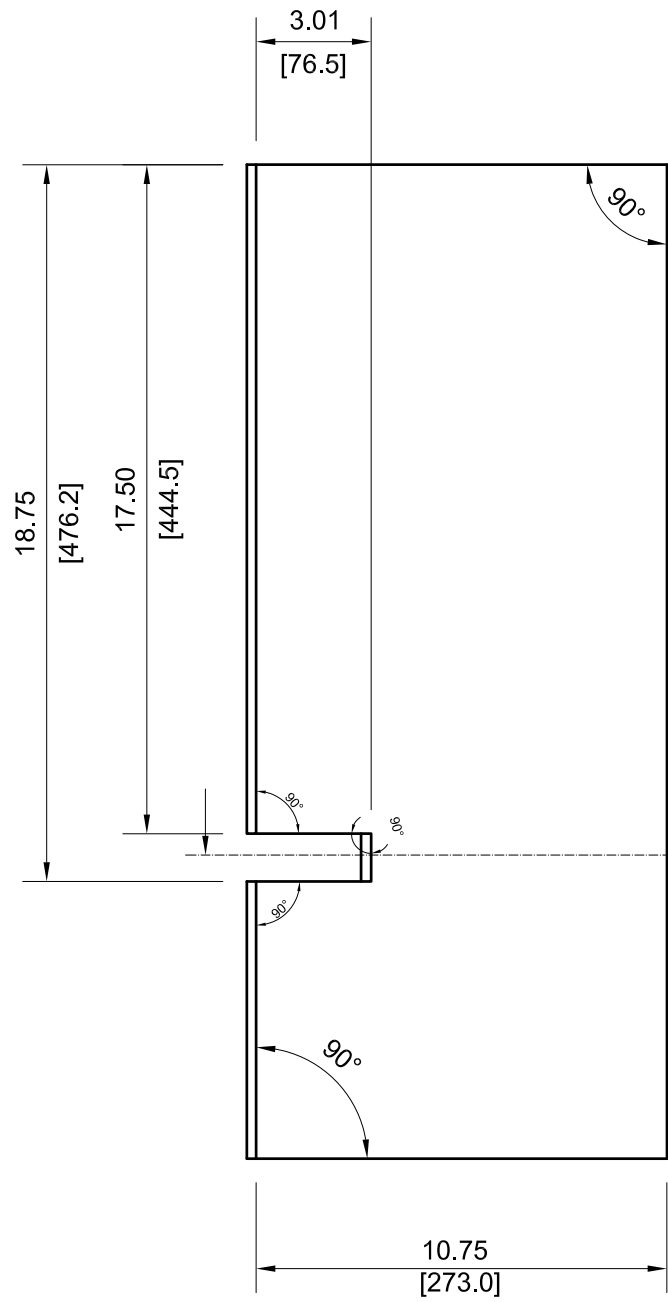

VIEW E7-120

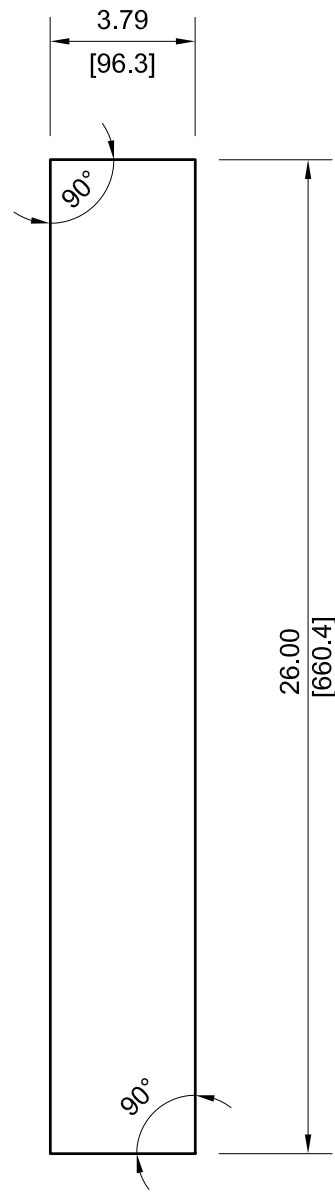

VIEW C8-120

— 255

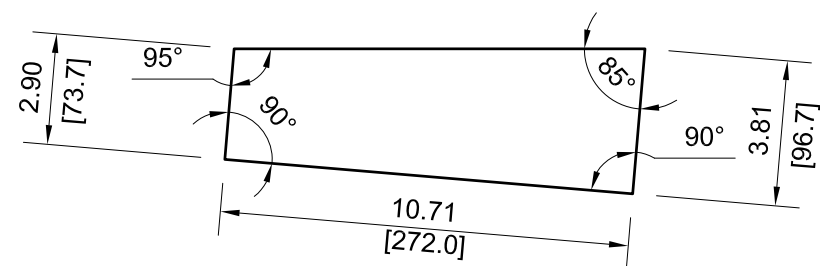
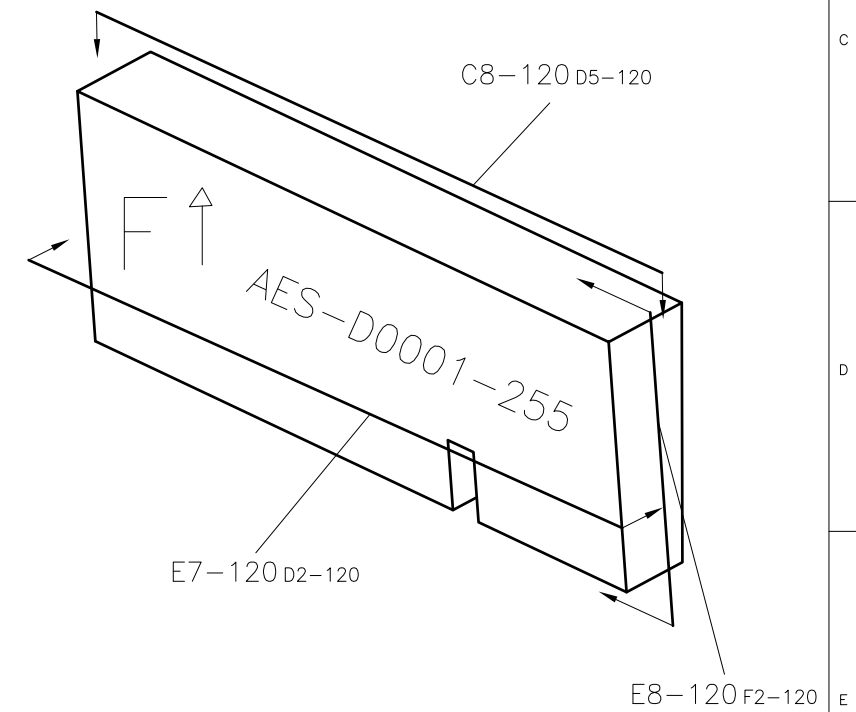

VIEW E8-120

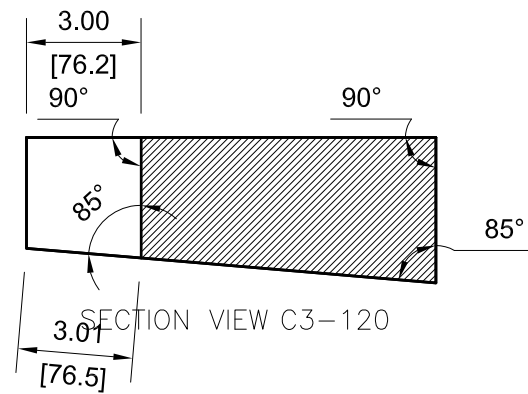

NOTE: ALL VIEWS TAKEN AS TRUE VIEWS PARALLEL TO SURFACE OF PART

	DRAWING NUMBER				
	AES-D0001				
SIZE	SCALE	SHEET	OF	REVISION	
A3	NONE	120	124	E	

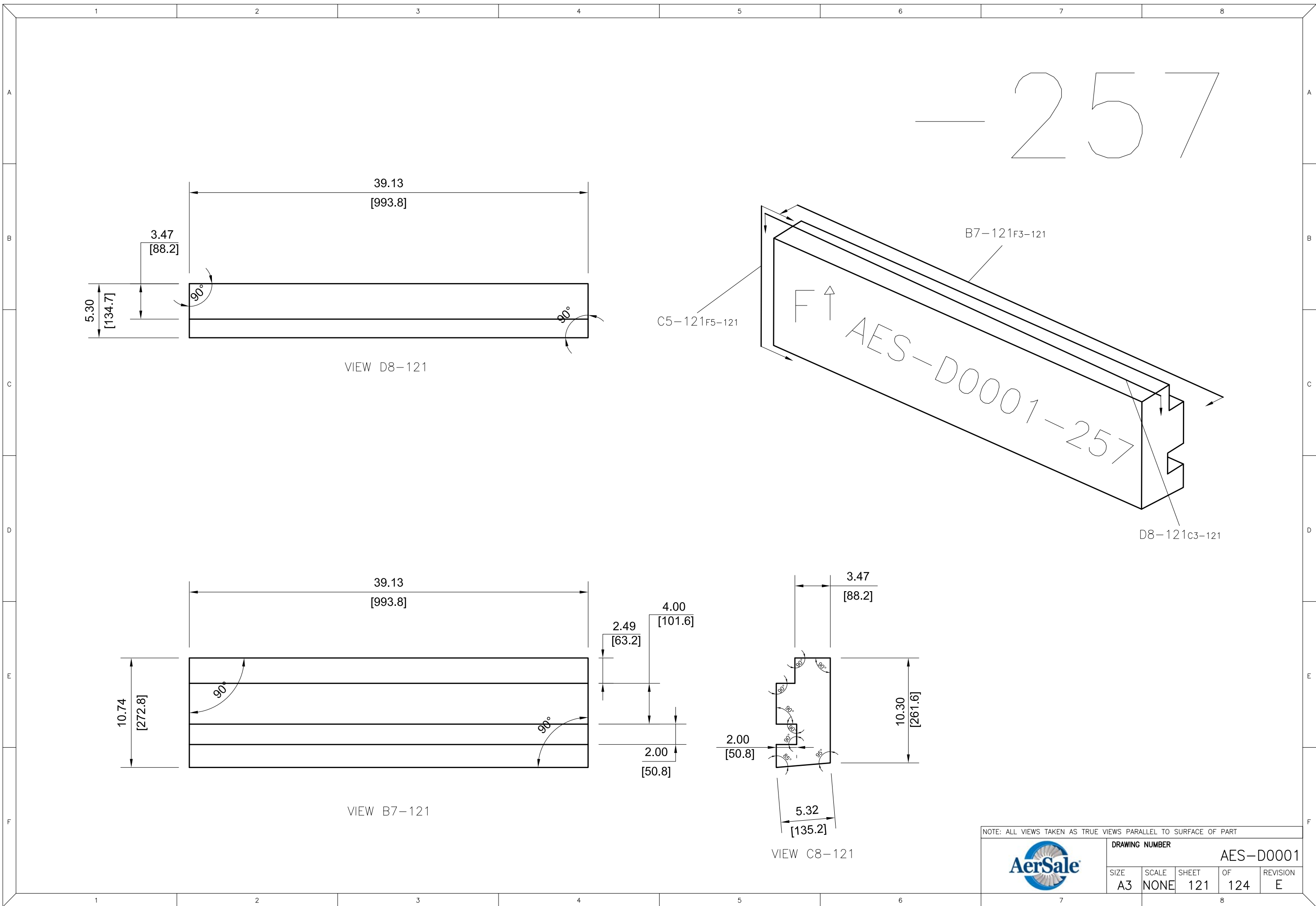

NOTE: ALL VIEWS TAKEN AS TRUE VIEWS PARALLEL TO SURFACE OF PART

		DRAWING NUMBER			
		AES-D0001			
SIZE	SCALE	SHEET	OF	REVISION	
A3	NONE	121	124	E	

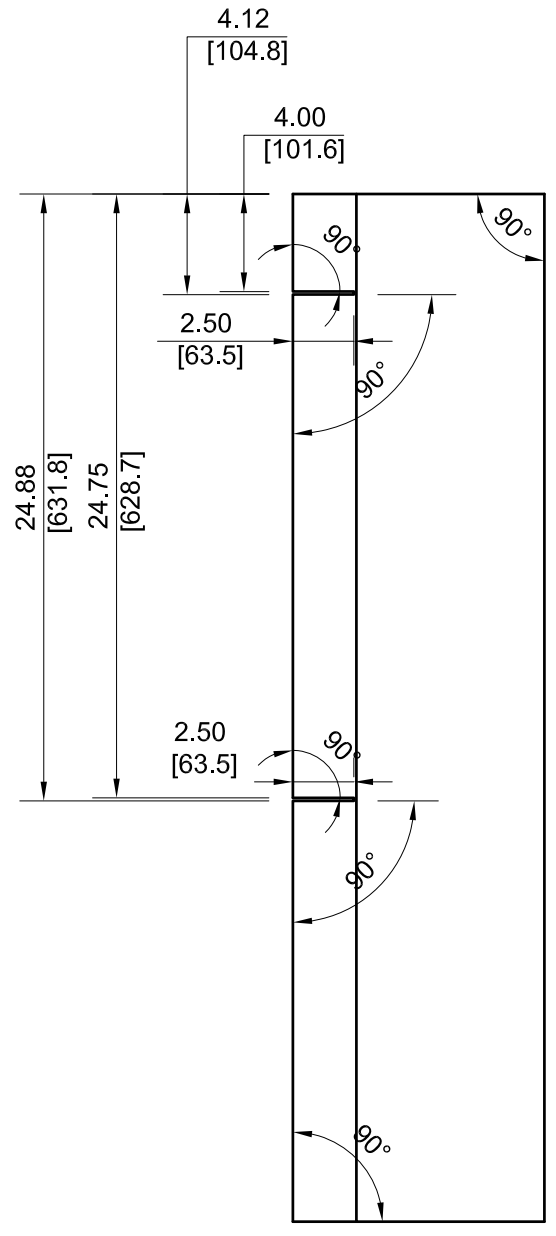

VIEW C7-122

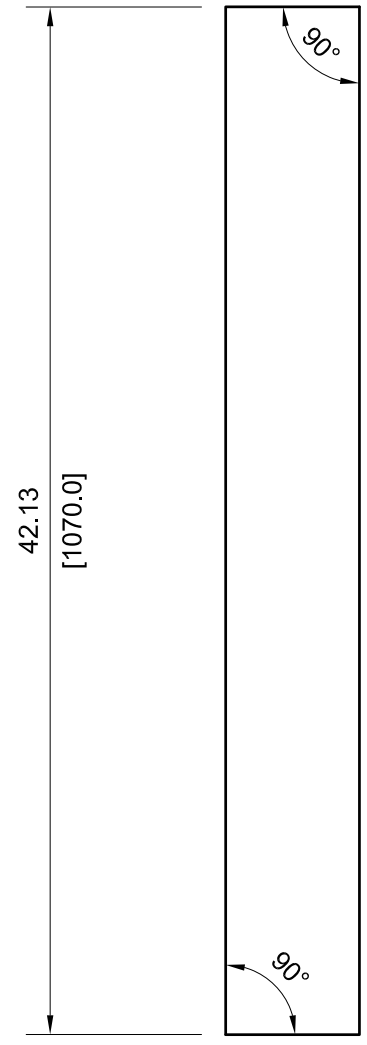

VIEW E7-122

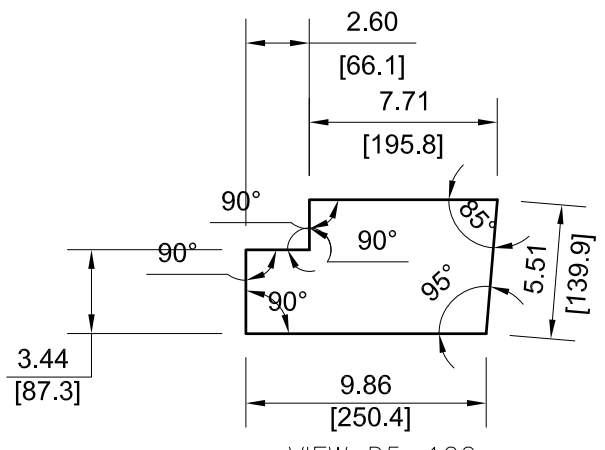

VIEW D5-122

— 259

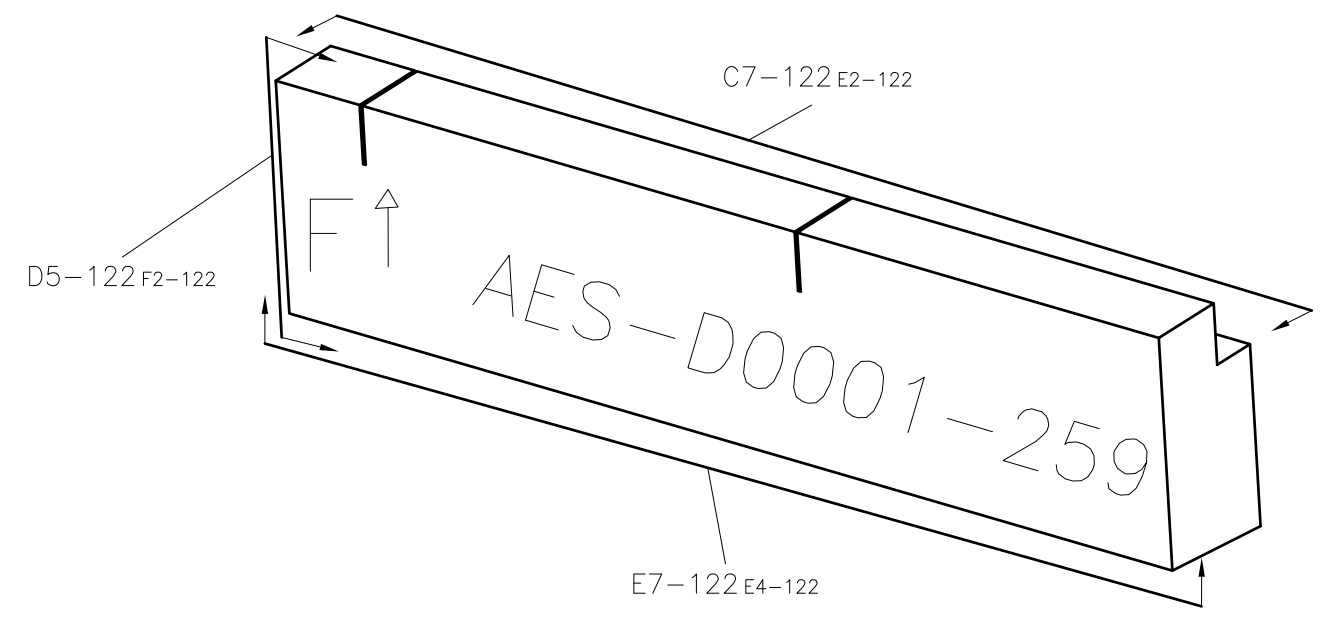

NOTE: ALL VIEWS TAKEN AS TRUE VIEWS PARALLEL TO SURFACE OF PART

		DRAWING NUMBER			
		AES-D0001			
SIZE	SCALE	SHEET	OF	REVISION	
A3	NONE	122	124	E	

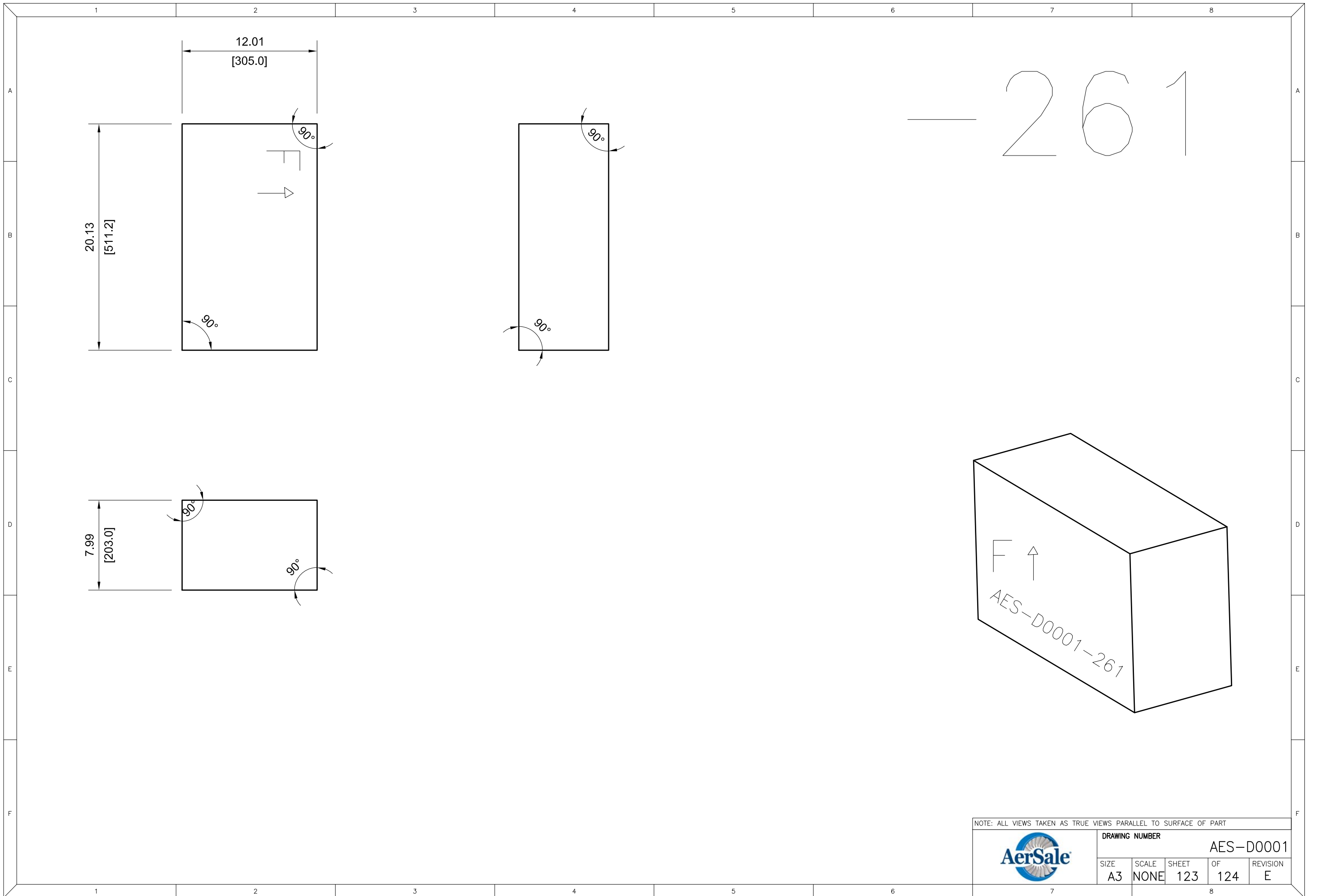

NOTE: ALL VIEWS TAKEN AS TRUE VIEWS PARALLEL TO SURFACE OF PART

	DRAWING NUMBER				AES-D0001
	SIZE	SCALE	SHEET	OF	REVISION
A3	NONE	123	124	E	

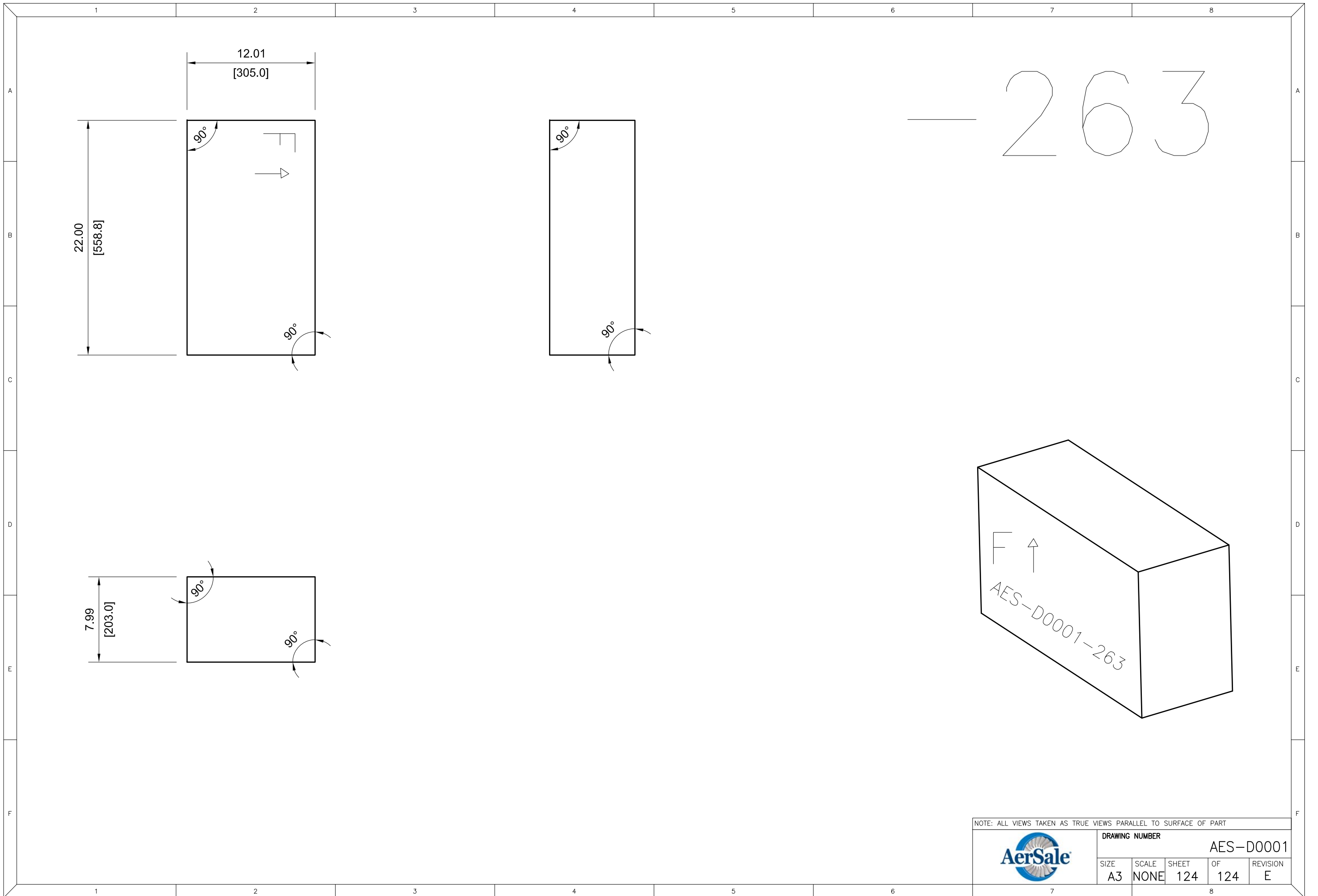

NOTE: ALL VIEWS TAKEN AS TRUE VIEWS PARALLEL TO SURFACE OF PART

	DRAWING NUMBER				AES-D0001
	SIZE	SCALE	SHEET	OF	REVISION
A3	NONE	124	124	E	