

REVISIONS		
REV	DESCRIPTION	DATE
-	INITIAL REVISION	OCT 29, 2015
A	GENERAL NOTES 1-9 UPDATED TO REFERENCE SAE AIR4171A SPECIFICATION AND TO PROVIDE MORE SPECIFIC INSTRUCTIONS. PART MARKING POSITION ON ALL VIEWS UPDATED TO SPECIFY PART MARKING ON LONGER SIDE OF FOAM BLOCK.	NOV 06, 2015
B	UPDATED DIMENSIONS THROUGHOUT DRAWING FOR ADDITIONAL DETAIL AND INSPECTION PURPOSES. ADDED GN10 TO PROVIDE GUIDANCE FOR DIMENSION CHANGES. UPDATED GN2, GN3 & GN9 WITH REVISED REFERENCES.	NOV 12, 2015
C	UPDATED SH12 WITH CORRECT PART.	NOV 17, 2015
D	ADDED NEW SET OF PART NUMBERS -79 THRU -399.	DEC 29, 2015
E	UPDATED DRAWING ON SH138, SH142, SH143, SH144, SH176, SH177, SH178 & SH202. CORRECTED VARIANT NUMBERS ON SH92, SH93, SH98 & SH99.	JAN 12, 2016
F	PART NUMBER TYPO FOR ITEMS 89-239 ON SHEET 1 CORRECTED FROM 'D0001' TO 'D0002'. PARTS - 1 TO -32, -39 TO -41, -43 TO -58, -60 TO -78 & -399 MADE OBSOLETE. MARKINGS ADDED TO THE FOAMS TO ASSIST INSTALLATION PROCESS. PARTS UPDATED -99, -101, -103, -197, -213, -267, -269, -271, -273, -275, -277, -279, -281, -283, -319, -323, -339, -341, -367, -371 DUE TO CHANGES IN DESIGN. ANGULAR AND LINEAR DIMENSIONS INTRODUCED IN ALL DRAWINGS. GN10 DELETED AND REMAINING NOTES RE-NUMBERED. GN8 AMENDED. GN10, GN11 & GN12 ADDED. FN1 INTRODUCED TO CLARIFY FOAM DIRECTION IN RELATION TO THE AIRCRAFT.	OCT 27, 2017

INDEX											
SHEET	REV	DESCRIPTION	NHA	SHEET	REV	DESCRIPTION	NHA	SHEET	REV	DESCRIPTION	NHA
0	F	INDEX	-								
1	F	PARTS LIST	-								
2	F	NOTES	-								

FOR FULL PART NUMBER & DRAWING SHEET REFERENCE REFER TO SH1 - PARTS LIST

<p>UNLESS OTHERWISE SPECIFIED DIMENSIONS ARE IN INCHES [MM] TOLERANCES ARE:</p> <table border="1" style="width: 100%; text-align: center;"> <tr> <td>.X ±.25 ±[6.35]</td> <td>.XX ±.25 ±[6.35]</td> <td>.XXX ±.25 ±[6.35]</td> <td>ANGLE ±2°</td> </tr> </table> <p>THIRD ANGLE PROJECTION</p> <p>DO NOT SCALE DRAWING</p>	.X ±.25 ±[6.35]	.XX ±.25 ±[6.35]	.XXX ±.25 ±[6.35]	ANGLE ±2°	<p style="font-size: small;">THE INFORMATION CONTAINED HEREIN IS PROPRIETARY TO COMTECH AVIATION SERVICES AND SHALL NOT BE REPRODUCED OR DISCLOSED IN WHOLE OR IN PART OR USED FOR ANY DESIGN OR MANUFACTURE EXCEPT WHEN SUCH USER POSSESSES DIRECT, WRITTEN AUTHORIZATION FROM COMTECH AVIATION SERVICES.</p> <p style="text-align: center; font-weight: bold;">CAD DRAWING NOT TO BE REVISED BY HAND</p> <table border="1" style="width: 100%;"> <thead> <tr> <th>APPROVALS</th> <th>DATE</th> <th>APPROVALS</th> <th>DATE</th> </tr> </thead> <tbody> <tr> <td>DRAWN A. CHONG </td> <td>OCT 27 2017</td> <td>STRUCTURES N/A</td> <td></td> </tr> <tr> <td>CHECKED F. WAHAB </td> <td>OCT 27 2017</td> <td>SYSTEMS N/A</td> <td></td> </tr> <tr> <td>INTERIORS N/A</td> <td></td> <td>APPROVED R. BLASCO </td> <td>OCT 27 2017</td> </tr> </tbody> </table>	APPROVALS	DATE	APPROVALS	DATE	DRAWN A. CHONG 	OCT 27 2017	STRUCTURES N/A		CHECKED F. WAHAB 	OCT 27 2017	SYSTEMS N/A		INTERIORS N/A		APPROVED R. BLASCO 	OCT 27 2017	<div style="text-align: center;"> <p>121 ALHAMBRA PLAZA SUITE 1700, CORAL GABLES FL 33134 USA WWW.AERSALE.COM</p> </div> <p>DRAWING TITLE</p> <h2 style="text-align: center;">FOAM BLOCK WING SECTION</h2> <p>SIZE A3 DRAWING NUMBER AES-D0002 REV F</p> <p>SCALE NONE DATASET AES-D0002F SHEET 0 OF 167</p>
.X ±.25 ±[6.35]	.XX ±.25 ±[6.35]	.XXX ±.25 ±[6.35]	ANGLE ±2°																			
APPROVALS	DATE	APPROVALS	DATE																			
DRAWN A. CHONG 	OCT 27 2017	STRUCTURES N/A																				
CHECKED F. WAHAB 	OCT 27 2017	SYSTEMS N/A																				
INTERIORS N/A		APPROVED R. BLASCO 	OCT 27 2017																			

GENERAL NOTES:

- GN1 FOAM TO BE IN ACCORDANCE WITH MIL SPEC MIL-PRF-87260B, CLASS 2 - GRADE 1 (COARSE PORE).
- GN2 IF BULK FOAM MATERIAL IS PROVIDED, THE FOAM SHOULD BE RECEIVED IN A MULTIPACKED CONFIGURATION FROM THE SUPPLIER TO ENSURE NO CONTAMINATION. MULTIPLE BUNS MAY BE CONTAINED IN A PACKAGE BUT EACH BUN MUST BE INDIVIDUALLY PACKED. UPON RECEIPT OF THE PACKAGES, CHECK THE PACKAGING FOR DAMAGE. IF DAMAGE IS PRESENT, CHECK THE FOAM FOR DAMAGE / CONTAMINATION. REFER TO SAE SPECIFICATION AIR4170 REV. A, PARAGRAPH 3.6.1 FOR INFORMATION ON PACKAGING DAMAGE.
- GN3 STORAGE OF THE FOAM MUST BE IN UNDAMAGED PACKAGING AWAY FROM ULTRAVIOLET LIGHT AND IN AN ENVIRONMENT WHERE CONTAMINATION IS AVOIDED. REFER TO SAE SPECIFICATION AIR4170 REV. A, PARAGRAPH 3.6.1 FOR INFORMATION ON PACKAGING DAMAGE.
- GN4 THE FABRICATOR'S MANUFACTURING AREA SHOULD MEET REQUIRED CLEANLINESS TO CONTROL CONTAMINANTS THAT WOULD ADVERSELY AFFECT THE MATERIAL OR ITS FUNCTIONALITY. IT IS EXTREMELY IMPORTANT TO CONTROL SUCH CONTAMINANTS AS FOREIGN PARTICLES, METAL PARTICLES, DUST, SUNLIGHT, WATER, WATER VAPOR STEAM, HARMFUL LIQUIDS, AND HARMFUL GASES. MANUFACTURING MANAGEMENT SHOULD ADDRESS THE REQUIREMENTS IDENTIFIED IN SAE SPECIFICATION AIR4170 REV. A, PARAGRAPH 3.6.3.
- GN5 CUTTING AND SHAPING OF INDIVIDUAL FOAM COMPONENTS CAN BE ACCOMPLISHED BY THE FOLLOWING METHODS:
A. HOT WIRE CUTTING (SEE SAE SPECIFICATION AIR4170 REV. A, PARAGRAPH 3.6.3.1).
B. MECHANICAL BLADE TYPE CUTTING (BAND SAW, ELECTRIC KNIFE) (SEE SAE SPECIFICATION AIR4170 REV. A, PARAGRAPH 3.6.3.2)
C. SPECIALLY DESIGNED / MANUFACTURED SMOOTH BLADE TYPE CUTTING TOOLS.
- GN6 HANDLING OF RETICULATED POLYURETHANE FOAM SHOULD NOT RESULT IN THE TRANSFER OF FOREIGN MATERIALS ONTO, OR INTO THE FOAM STRUCTURE. THE CLOTHING WORN BY PERSONNEL FABRICATING THE COMPONENTS/KITS SHOULD NOT BE A SOURCE OF CONTAMINATION TO THE FUEL CELL BAFFLE MATERIAL. REFER TO SAE SPECIFICATION AIR4170 REV. A, PARAGRAPH 3.6.3.3 FOR FURTHER DETAILS.
- GN7 UPON COMPLETION OF FABRICATION AND BEFORE FINAL INSPECTION, COMPONENTS WILL REQUIRE A FINAL CLEANING TO REMOVE ANY FOAM DEBRIS OR CONTAMINANTS LEFT FROM THE FABRICATING PROCESS. ALL COMPONENTS MUST BE BOUNCED AND THOROUGHLY SCRUBBED ON A SCREEN OR HARDWARE CLOTH TO REMOVE LOOSE PARTICLES OF FOAM AND/OR BEADS OF MELTED FOAM AS A RESULT OF FABRICATION. REFER TO SAE SPECIFICATION AIR4170 REV. A, PARAGRAPH 3.6.3.4 FOR INFORMATION ON CLEANING.
- GN8 COMPONENT IDENTIFICATION NUMBERS/LETTERS MUST BE APPLIED TO EACH COMPONENT AFTER FABRICATION IN THE POSITION SHOWN ON THE DRAWINGS. REFER GN11 & GN12 FOR ADDITIONAL DETAILS ON MARKING. PART MARKING MUST ALSO INCLUDE DATE OF FABRICATION. INK TO BE IN ACCORDANCE WITH FEDERAL SPECIFICATION A-A-208() IN A CONTRASTING COLOUR.
- GN9 IMMEDIATELY UPON COMPLETING THE CLEANING AND IDENTIFICATION MARKING OF A COMPONENT IT SHALL BE PACKAGED TO PREVENT POSSIBLE CONTAMINATION. MINIMUM LEVEL OF PROTECTION WHEN PACKAGING SHOULD BE AS FOLLOWS:
- EACH INDIVIDUAL COMPONENT SHALL BE WRAPPED IN A 4-MIL, BLACK POLYETHYLENE FILM, TAPED OR SEALED CLOSED, AND PROPERLY IDENTIFIED
- INDIVIDUALLY WRAPPED COMPONENTS SHALL THEN BE MULTIPACKED INTO COMMERCIAL GRADE CORRUGATED CARTONS, AND SEALED CLOSED WITH TAPE. MARKINGS ON THE EXTERIOR CARTON SHALL IDENTIFY THE CONTENTS. THE PACKAGED COMPONENTS/KITS SHALL BE STORED IN AN AREA TO PROTECT THEM FROM THE OUTDOOR ENVIRONMENT.
- REFER TO SAE SPECIFICATION AIR4170 REV. A, PARAGRAPH 3.6.6 FOR INFORMATION ON PACKAGING AND STORAGE
- GN10 MARKINGS ON THE FOAM REPRESENT THE FOLLOWING:
'F' - FACE OF FOAM FACING FORWARD OF THE AIRCRAFT
'A' - FACE OF FOAM FACING AFT OF THE AIRCRAFT
↑ - 'THIS END UP' ARROW
- GN11 PART NUMBER AND ALL MARKINGS PER GN11 TO BE MARKED IN POSITION SHOWN ON DRAWING. THE MINIMUM TEXT HEIGHT FOR BOTH FACE OF FOAM ('F' OR 'A') AND ARROW IS 2.5 INCHES AND THE MAXIMUM TEXT HEIGHT IS 5 INCHES. THE TEXT HEIGHT FOR PART NUMBER IS 1 INCH. CHANGE TEXT HEIGHT OF MARKINGS AS REQUIRED. HOWEVER, IF CONSTRAINED FOR SPACE PART NUMBER CAN BE MARKED ON ADJACENT FACES. ARROWS NEED TO BE CONSPICUOUS.
- GN12 PAGE 0 CONTAINS REV BLOCK, DOC NAME/REV/DATE/NUMBER, TOLERANCES, SIGNATURES AND INDEX.

FLAG NOTES:

- 1 → ARROW INDICATES DIRECTION OF AIRCRAFT RELATIVE TO THE FOAM SECTION VIEW. THIS IS TO ASSIST MARKINGS ON THE FOAM BLOCK.

NOTE: ALL VIEWS TAKEN AS TRUE VIEWS PARALLEL TO SURFACE OF PART



DRAWING NUMBER				
AES-D0002				
SIZE	SCALE	SHEET	OF	REVISION
A3	NONE	2	167	F

-33 L SHOWN
 -34 R OPPOSITE

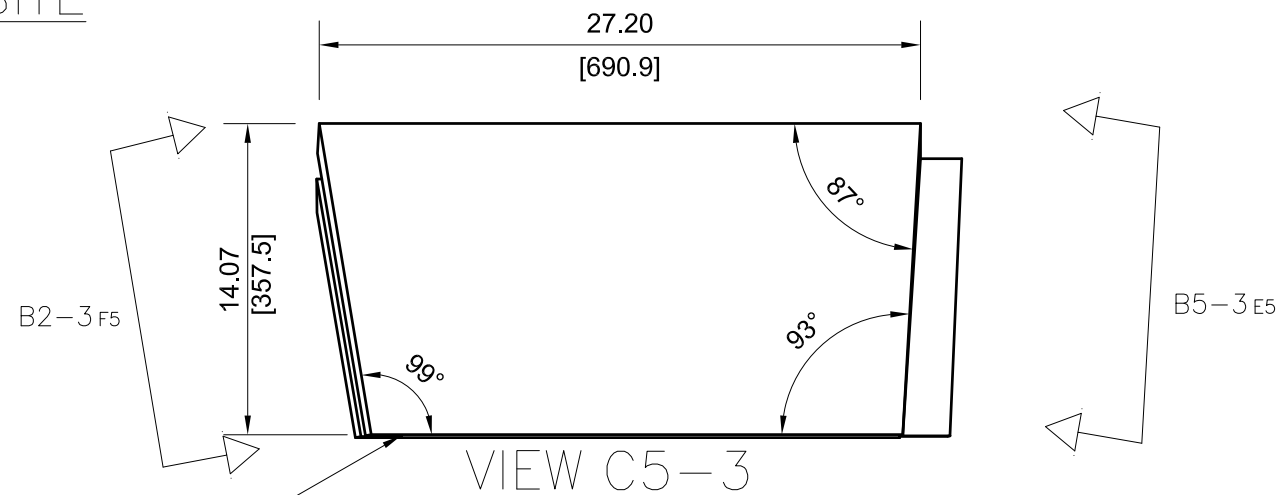

SLOPE OF GROOVE 100°

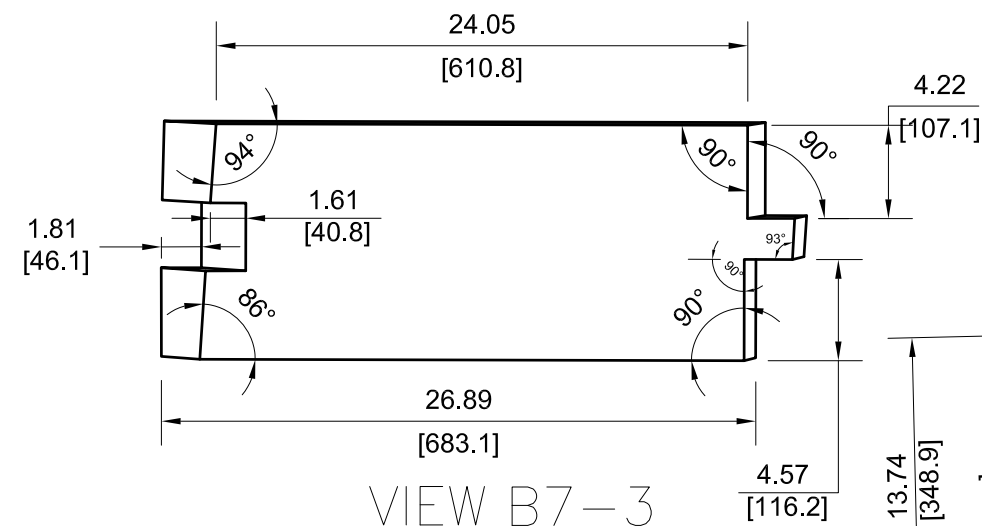

VIEW B7-3

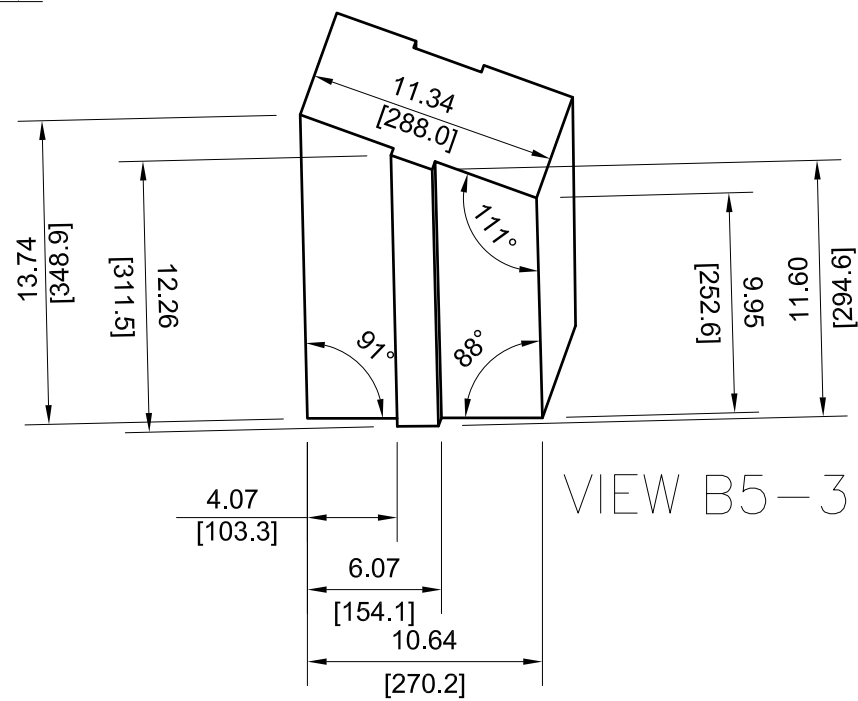

VIEW B5-3

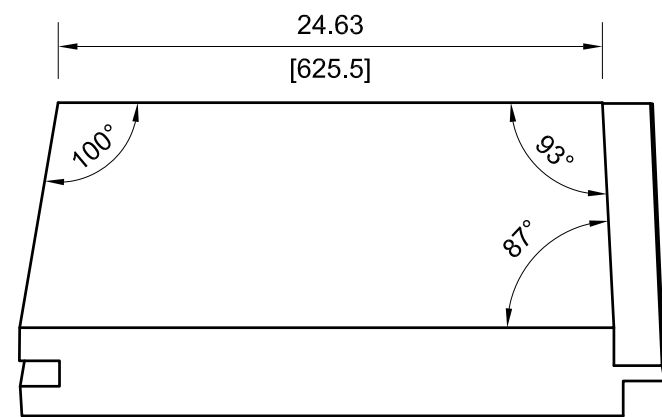

VIEW A7-3

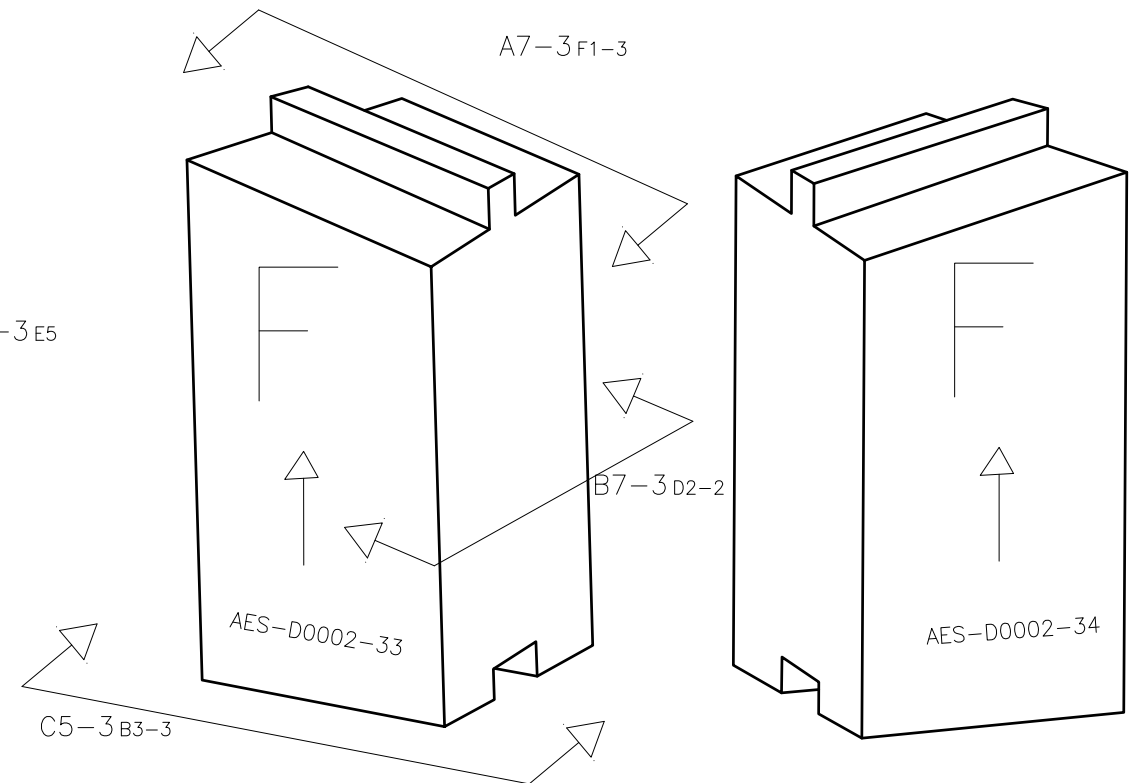

-33 L
 ISO VIEW

-34 R
 ISO VIEW

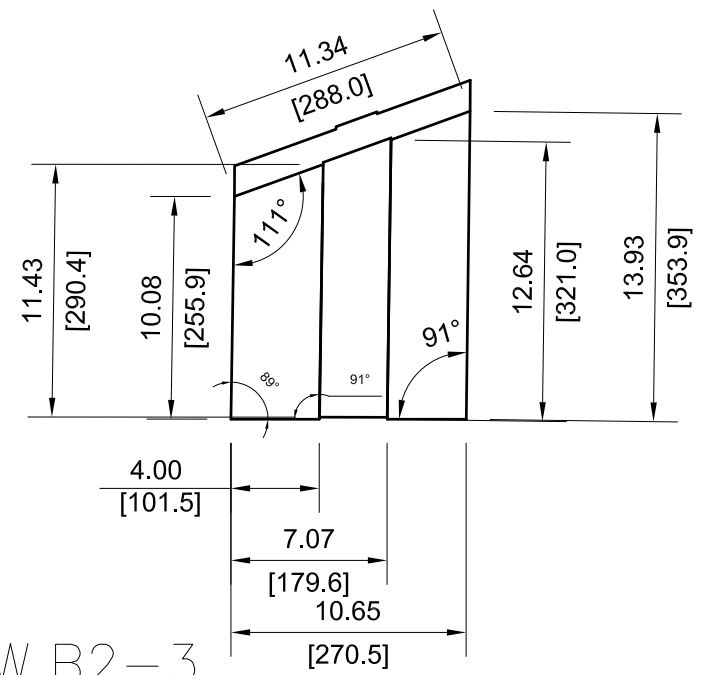

VIEW B2-3

NOTE: ALL VIEWS TAKEN AS TRUE VIEWS PARALLEL TO SURFACE OF PART

		DRAWING NUMBER			
		AES-D0002			
SIZE	SCALE	SHEET	OF	REVISION	
A3	NONE	3	167	F	

-35 L SHOWN
-36 R OPPOSITE

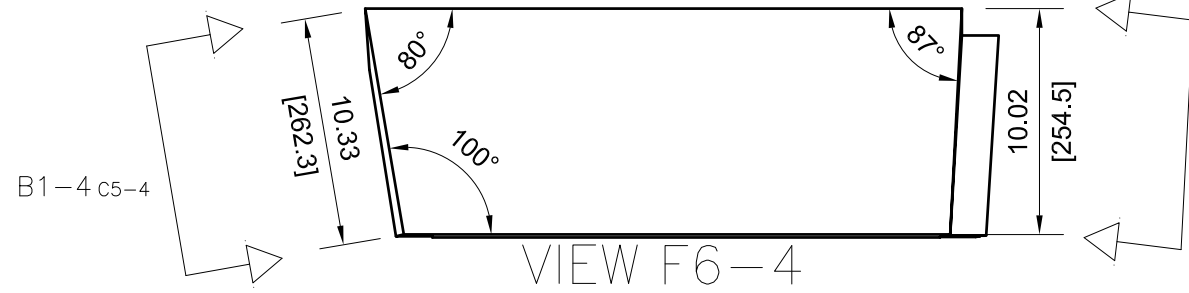

VIEW F6-4

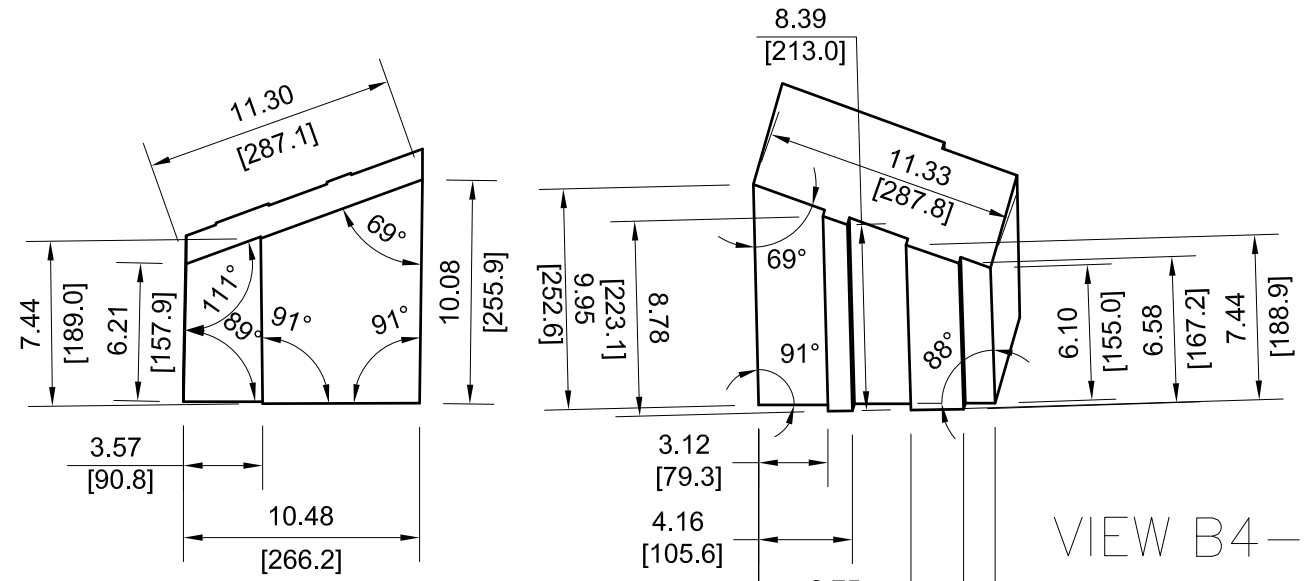

VIEW B1-4

VIEW B4-4

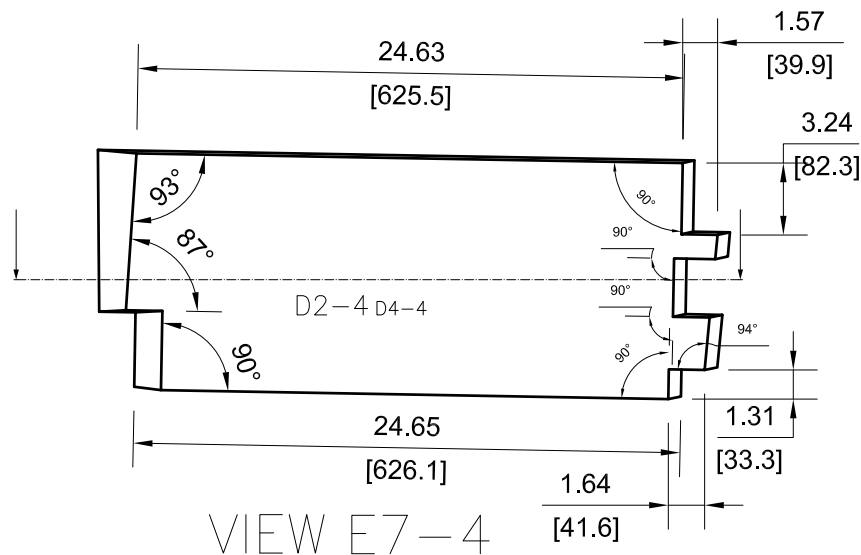

VIEW E7-4

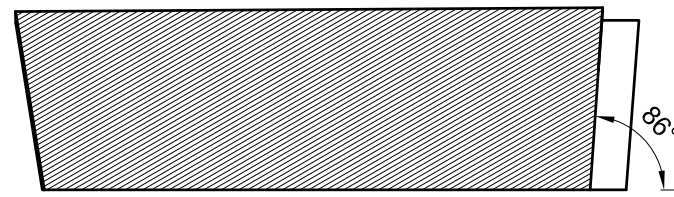

SECTION VIEW D2-4

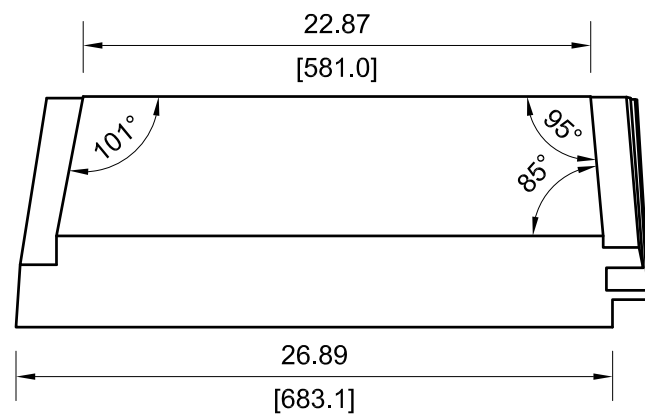

VIEW C7-4

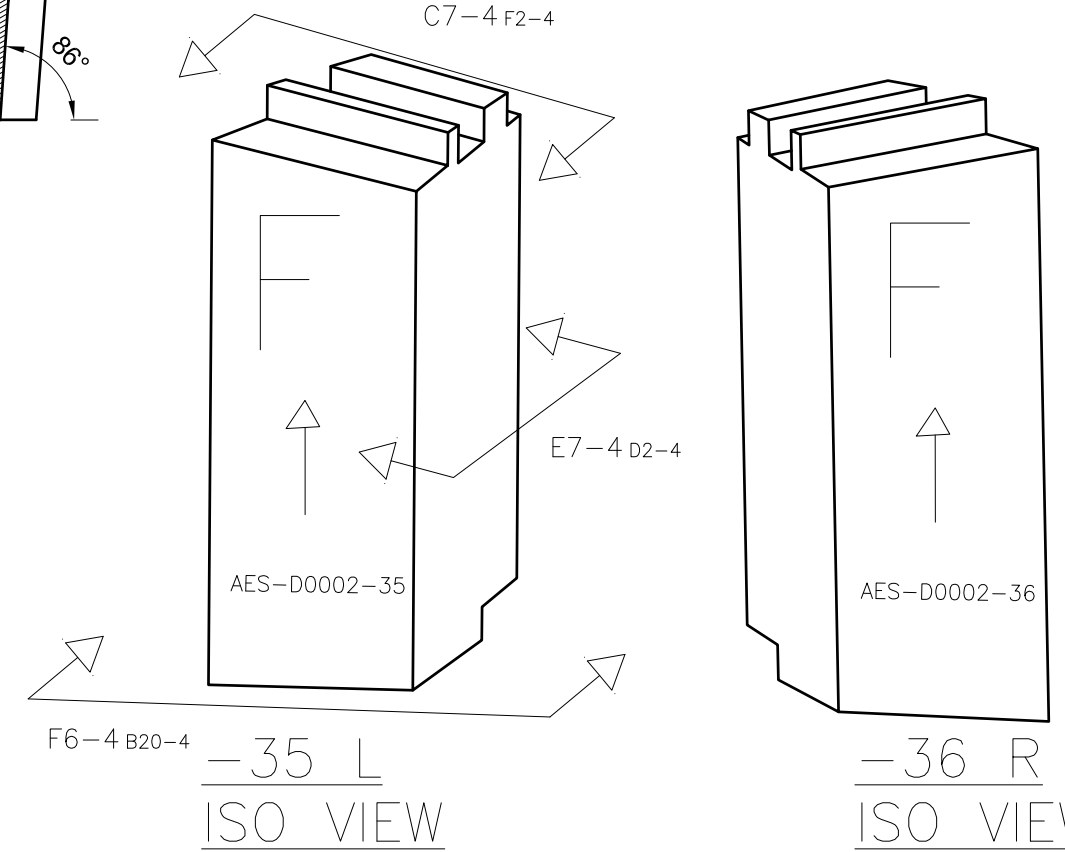

-35 L
ISO VIEW

-36 R
ISO VIEW

NOTE: ALL VIEWS TAKEN AS TRUE VIEWS PARALLEL TO SURFACE OF PART

		DRAWING NUMBER			
		AES-D0002			
SIZE	SCALE	SHEET	OF	REVISION	
A3	NONE	4	167	F	

-37 L SHOWN
-38 R OPPOSITE

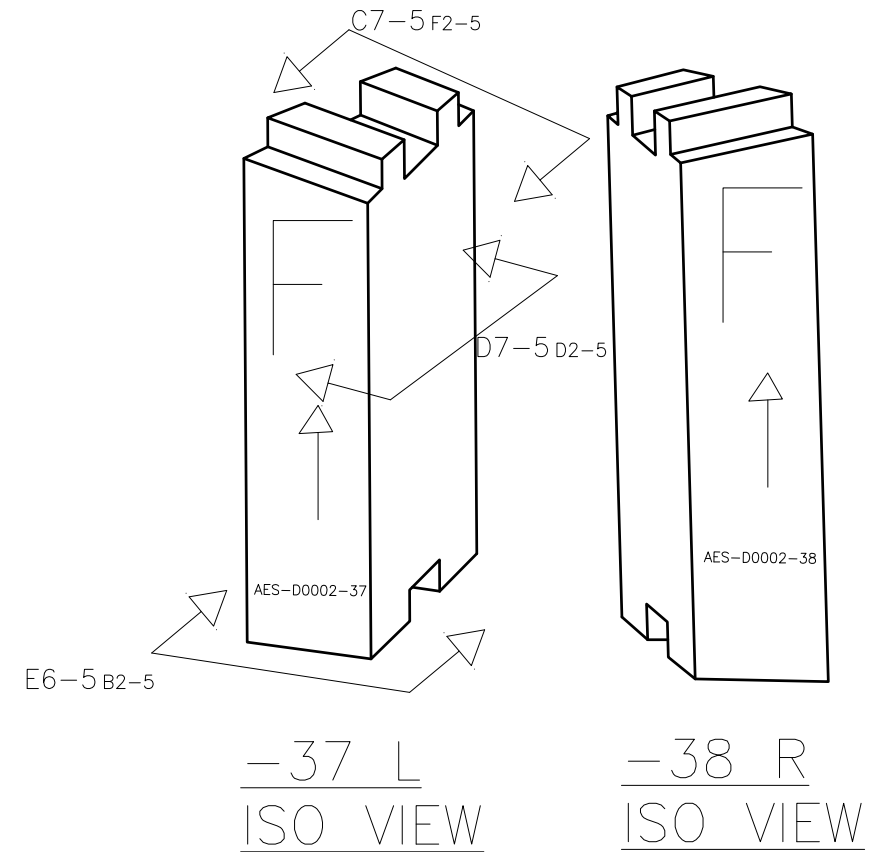
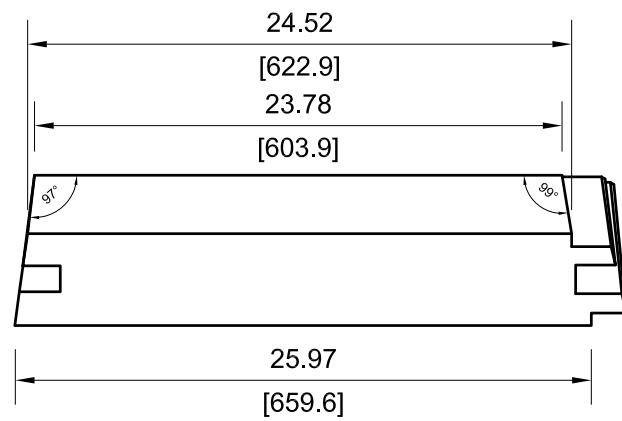
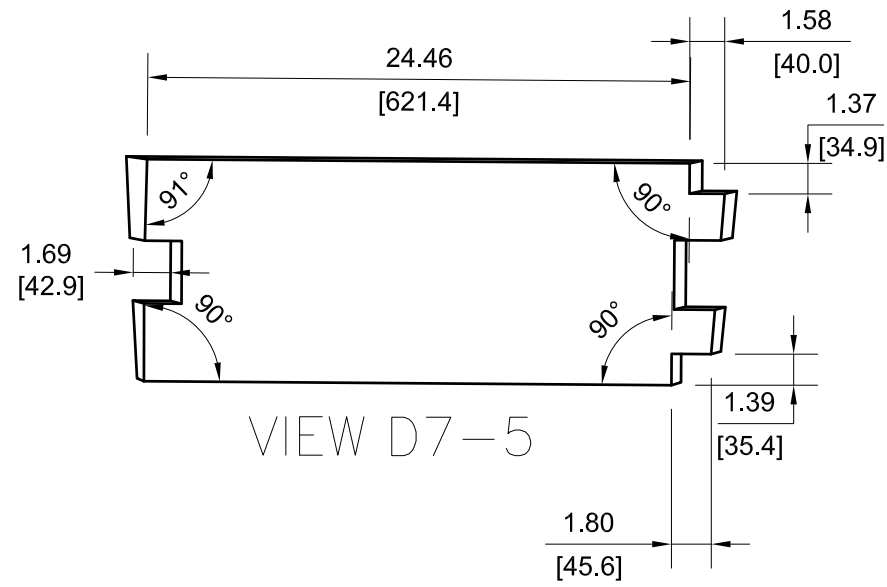
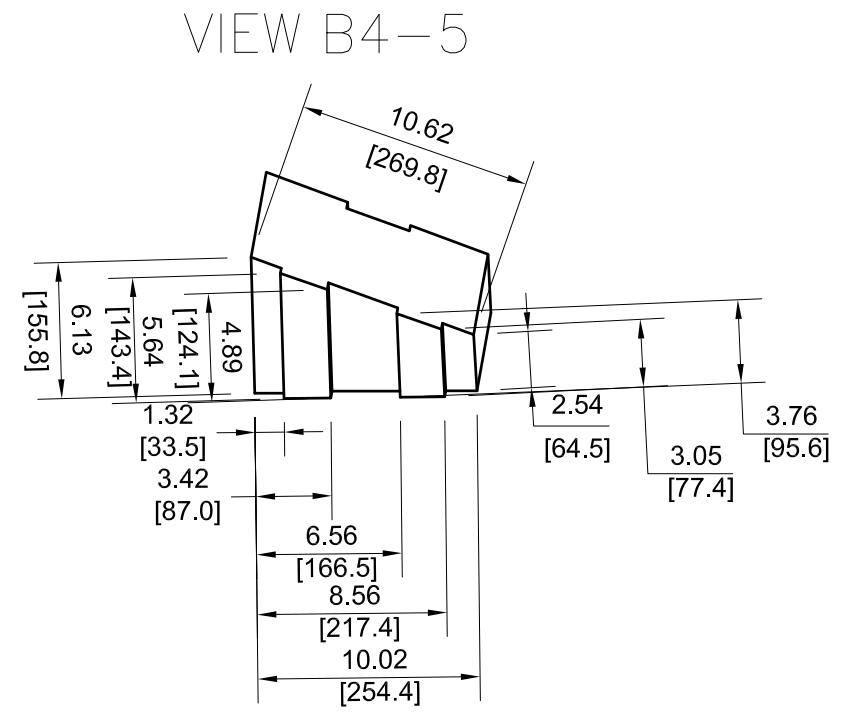

NOTE: ALL VIEWS TAKEN AS TRUE VIEWS PARALLEL TO SURFACE OF PART



DRAWING NUMBER				
AES-D0002				
SIZE	SCALE	SHEET	OF	REVISION
A3	NONE	5	167	F

-42

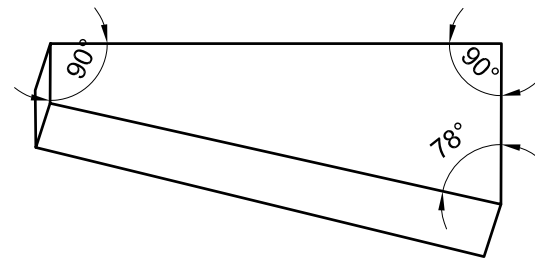

VIEW C3-6

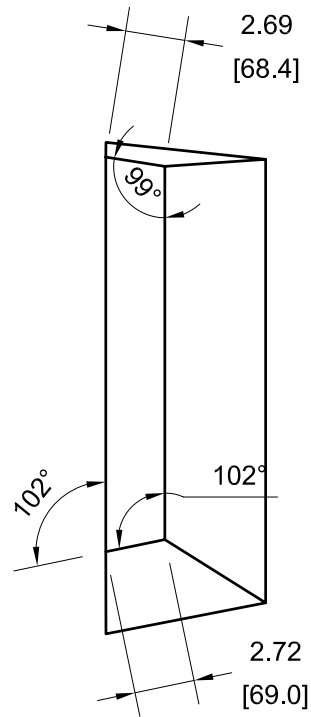
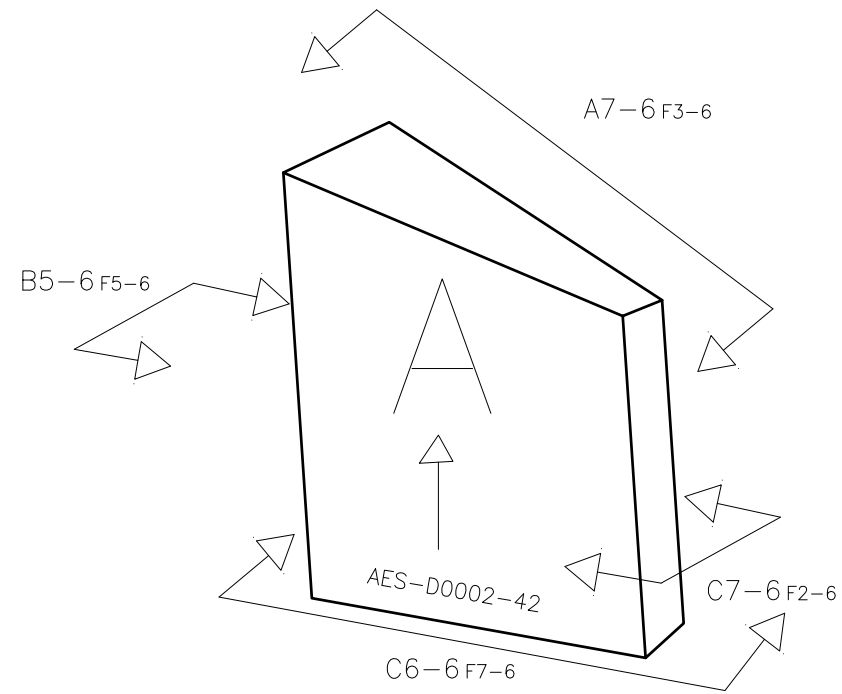

VIEW C7-6

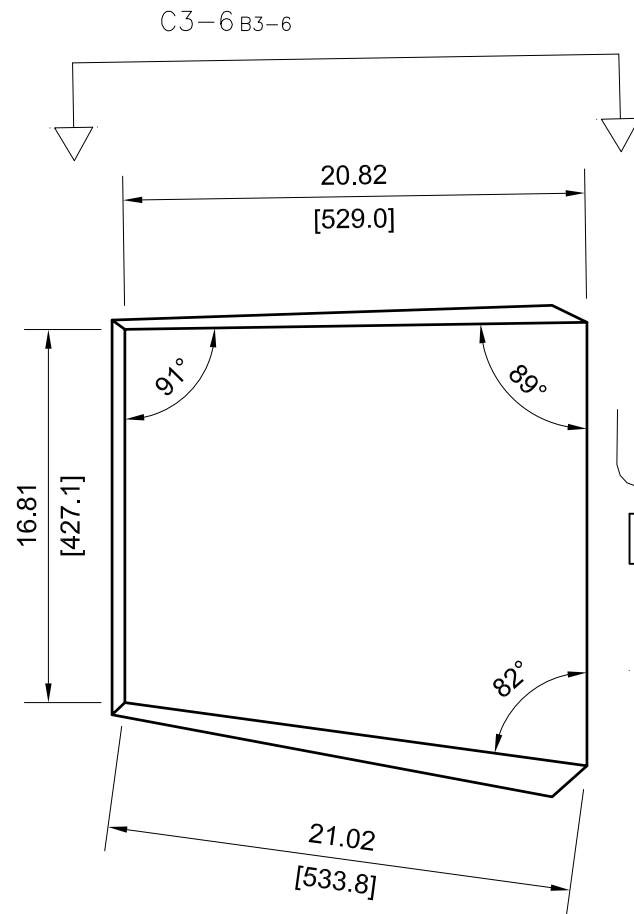

VIEW A7-6

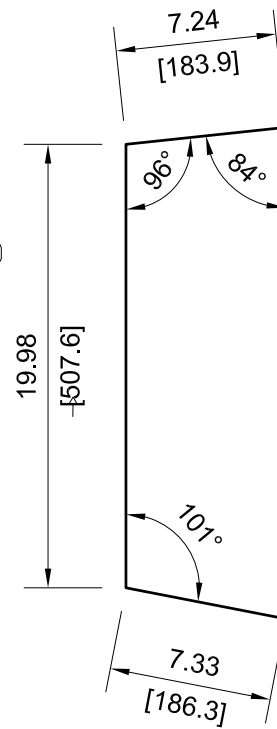
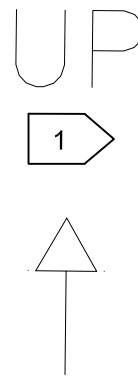

VIEW B5-6

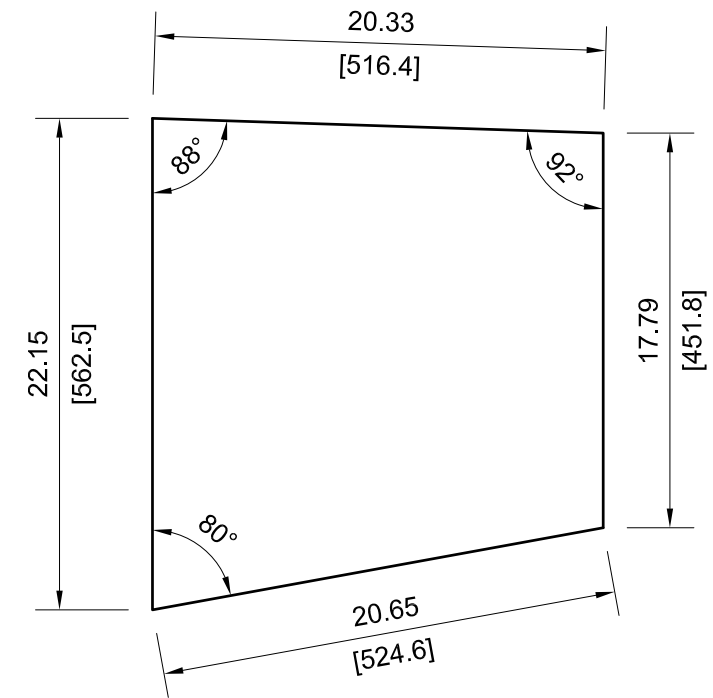

VIEW C6-6

NOTE: ALL VIEWS TAKEN AS TRUE VIEWS PARALLEL TO SURFACE OF PART

	DRAWING NUMBER				
	AES-D0002				
SIZE	SCALE	SHEET	OF	REVISION	
A3	NONE	6	167	F	

59

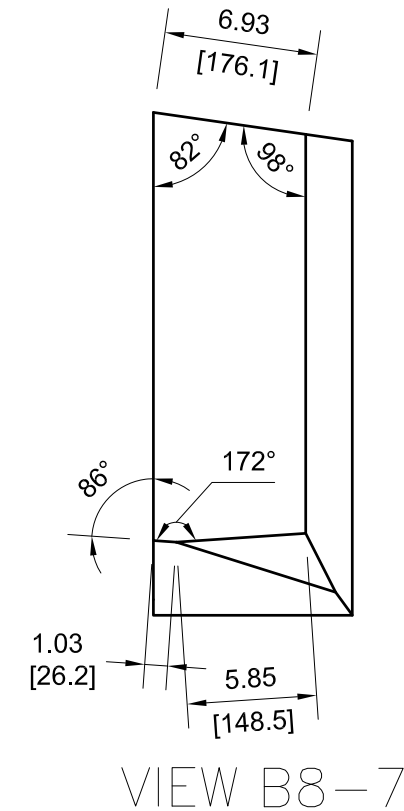
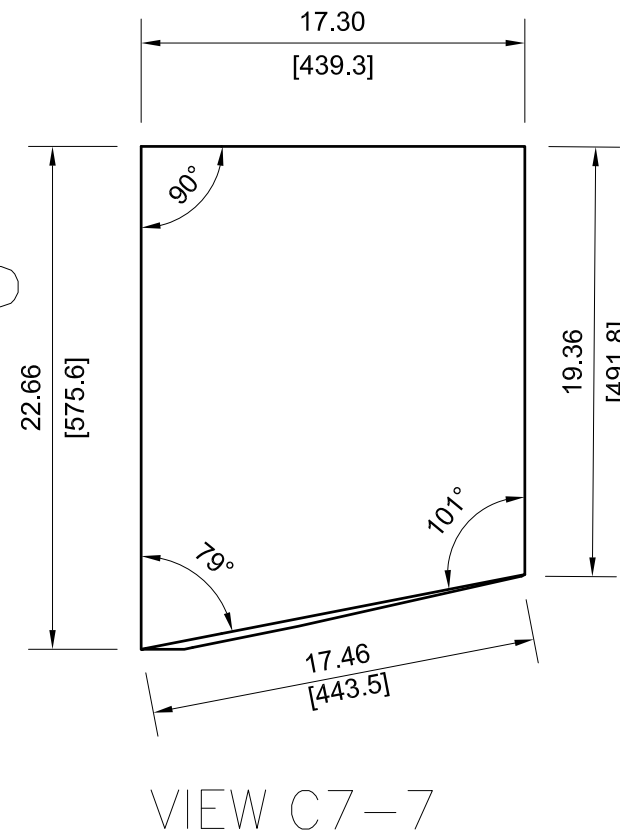
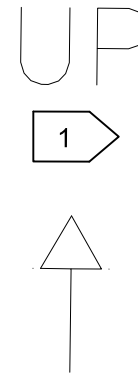
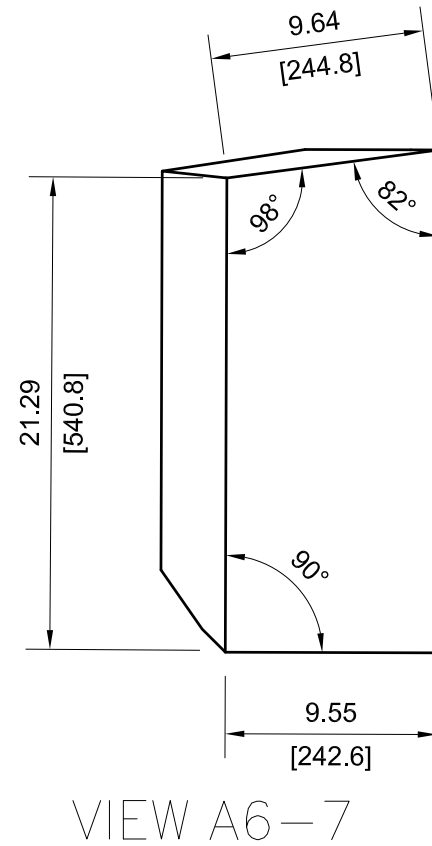
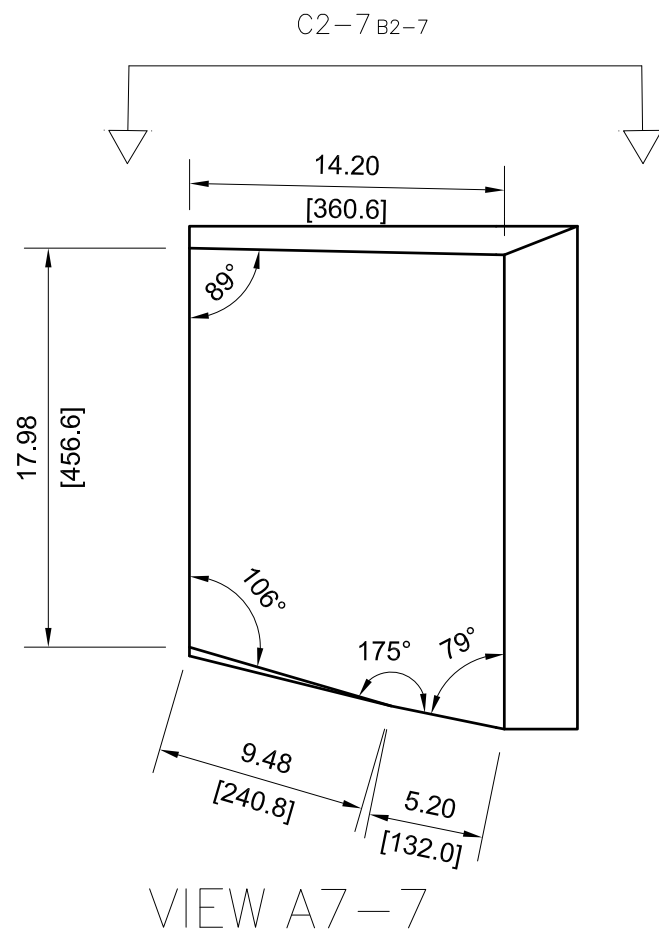
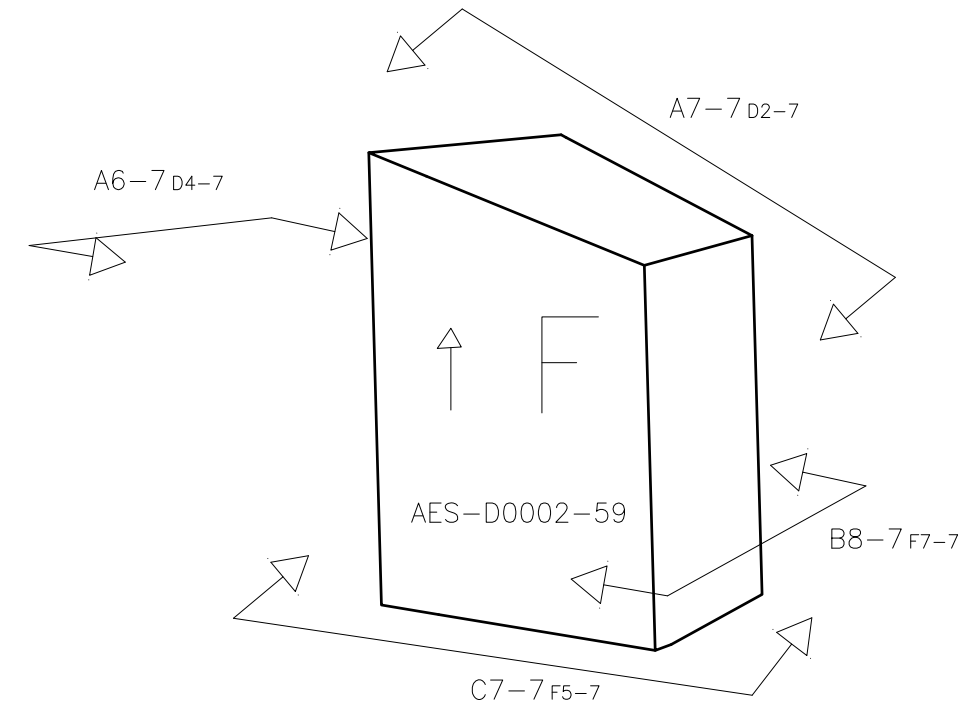
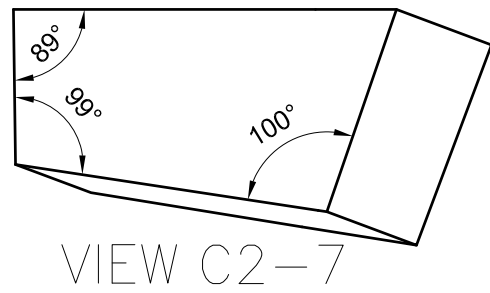

NOTE: ALL VIEWS TAKEN AS TRUE VIEWS PARALLEL TO SURFACE OF PART

	DRAWING NUMBER				
	AES-D0002				
SIZE	SCALE	SHEET	OF	REVISION	
A3	NONE	7	167	F	

-79

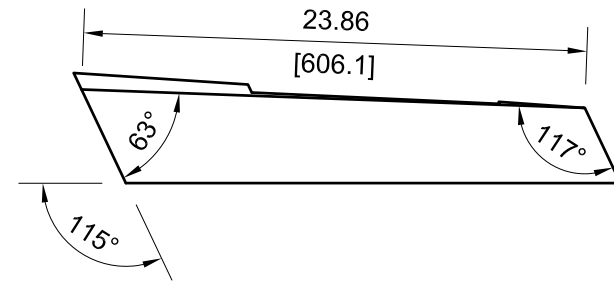

VIEW C4-8

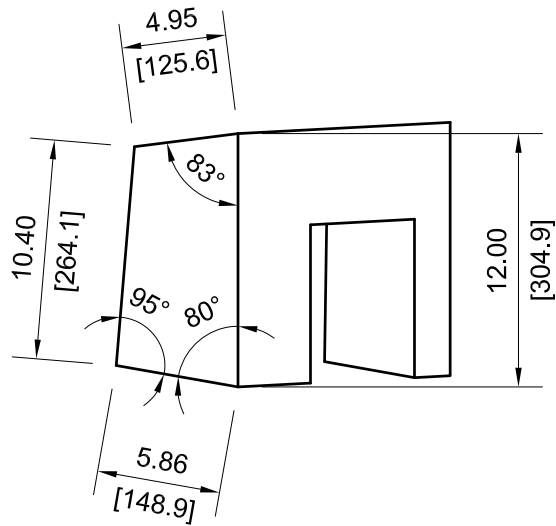
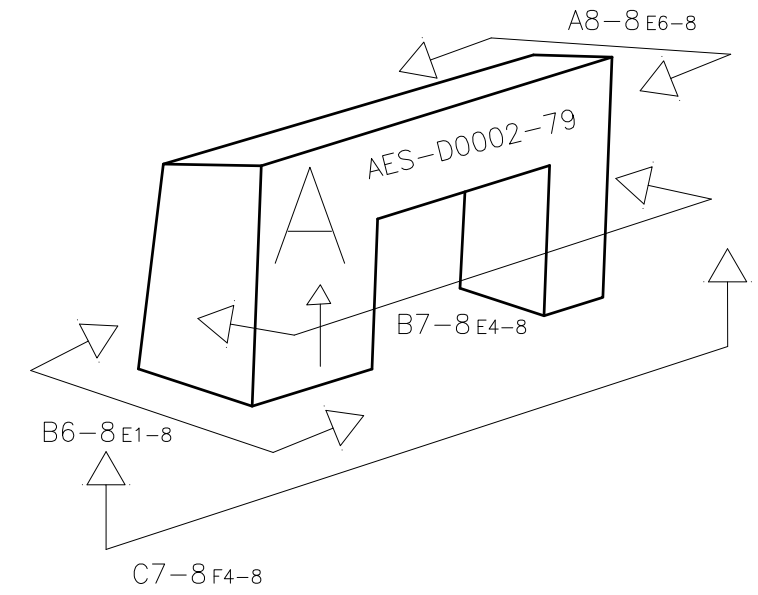

VIEW B6-8

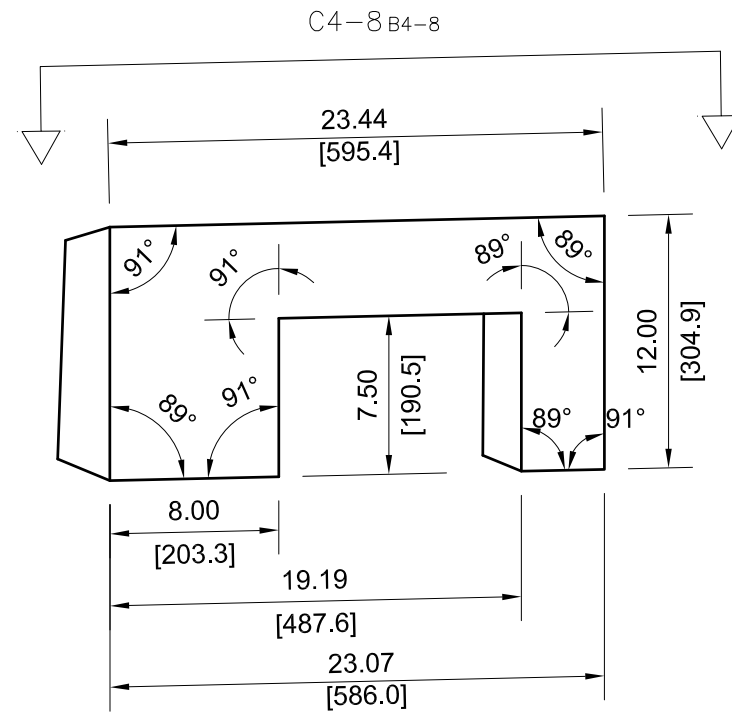

VIEW B7-8

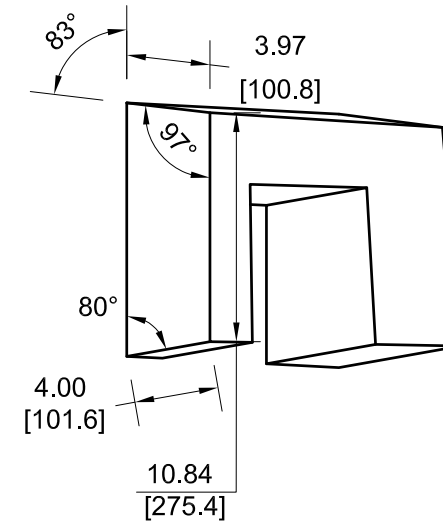

VIEW A8-8

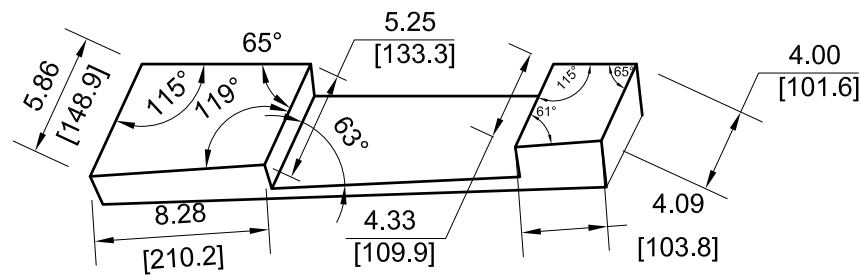

VIEW C7-8

NOTE: ALL VIEWS TAKEN AS TRUE VIEWS PARALLEL TO SURFACE OF PART

	DRAWING NUMBER				
	AES-D0002				
SIZE	SCALE	SHEET	OF	REVISION	
A3	NONE	8	167	F	

— 81

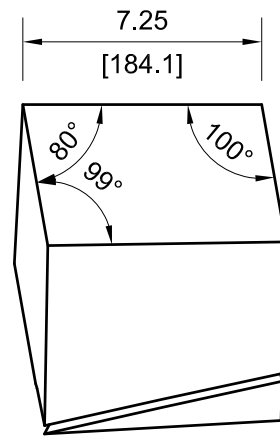

VIEW B3-9

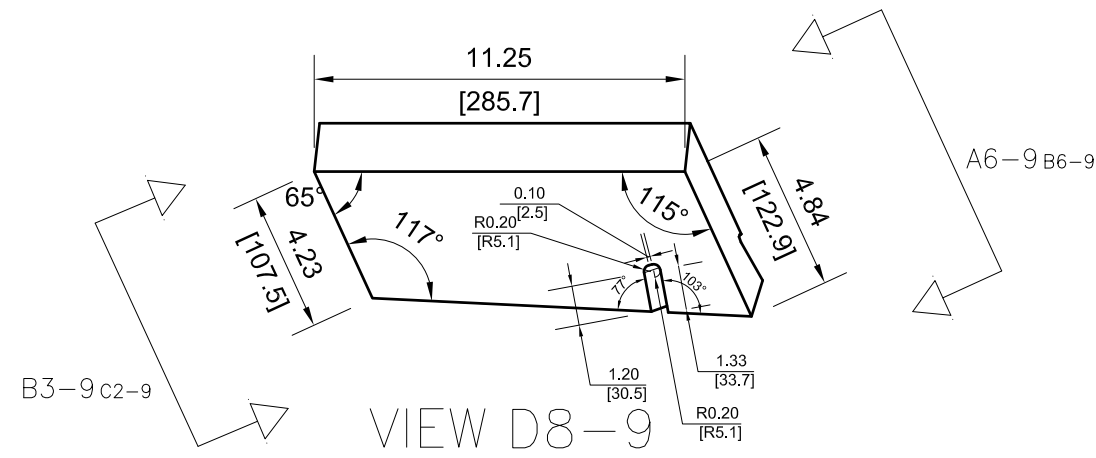

VIEW D8-9

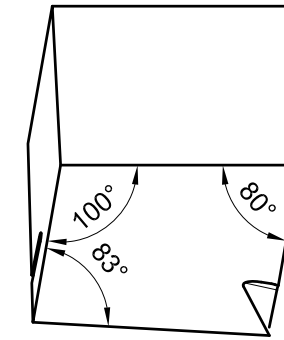

VIEW A6-9

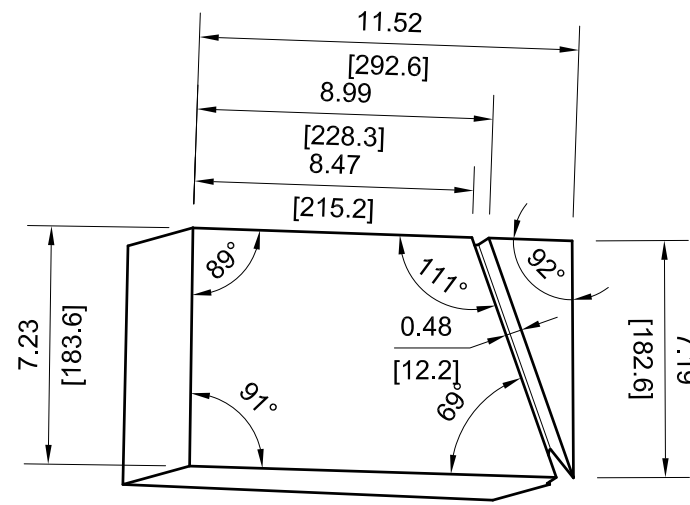

VIEW D7-9

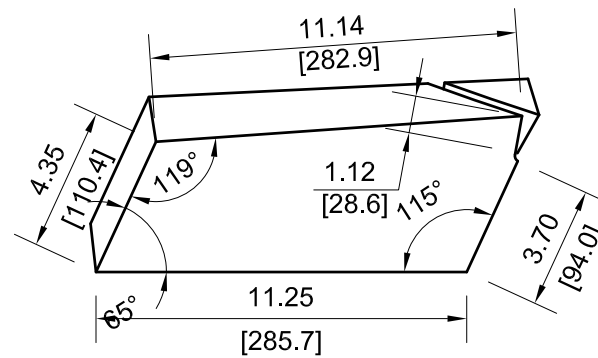

VIEW E8-9

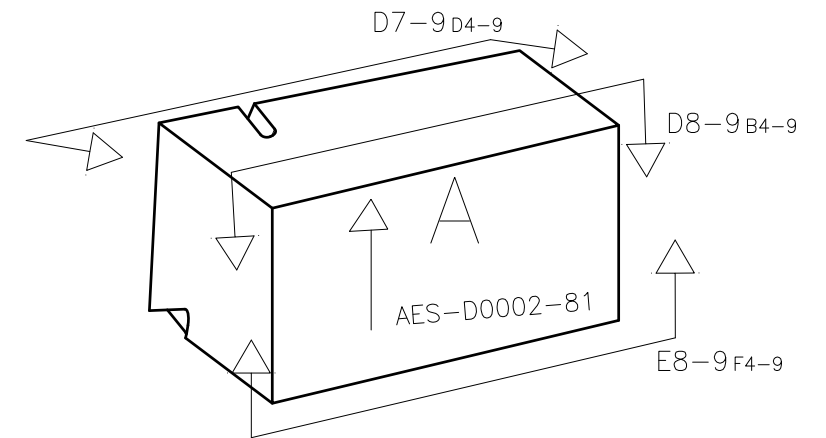

NOTE: ALL VIEWS TAKEN AS TRUE VIEWS PARALLEL TO SURFACE OF PART

	DRAWING NUMBER				
	AES-D0002				
SIZE	SCALE	SHEET	OF	REVISION	
A3	NONE	9	167	F	

- 83

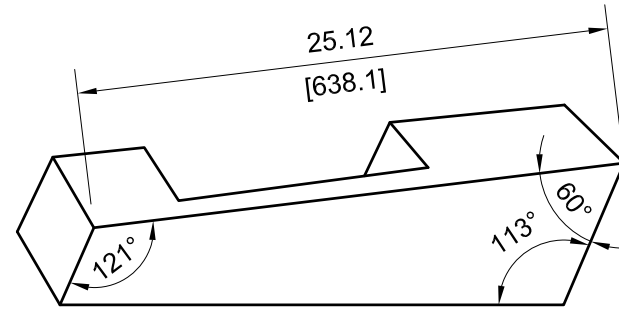

VIEW F7-10

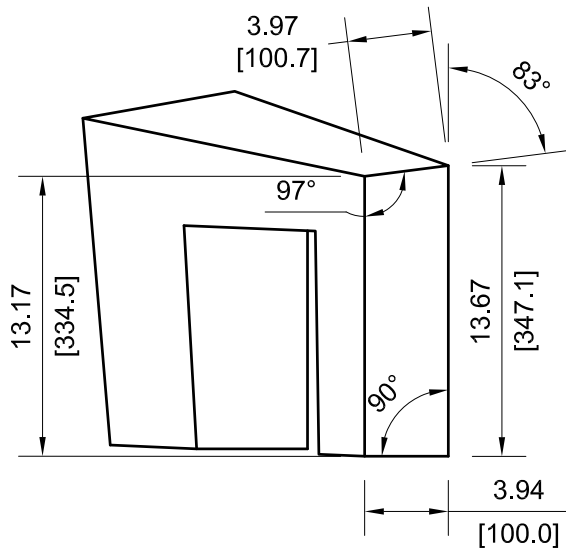

VIEW C3-10

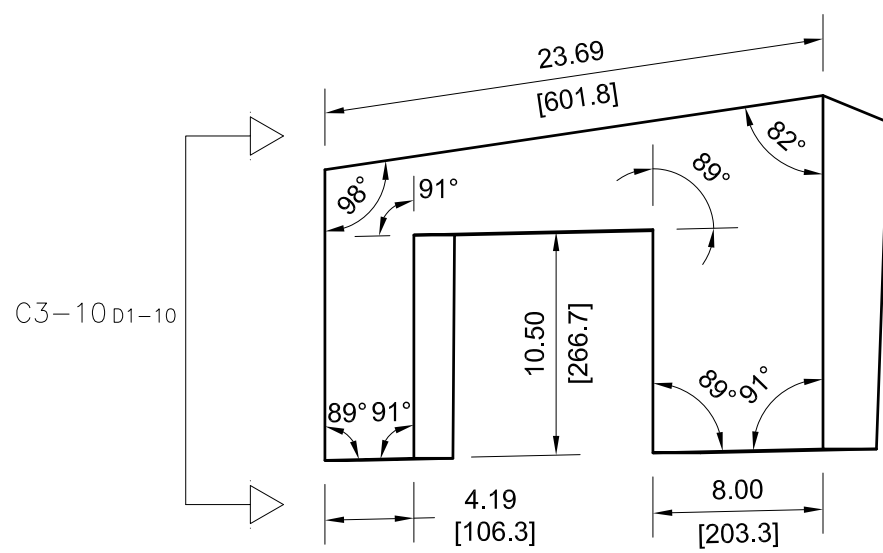

VIEW E8-10

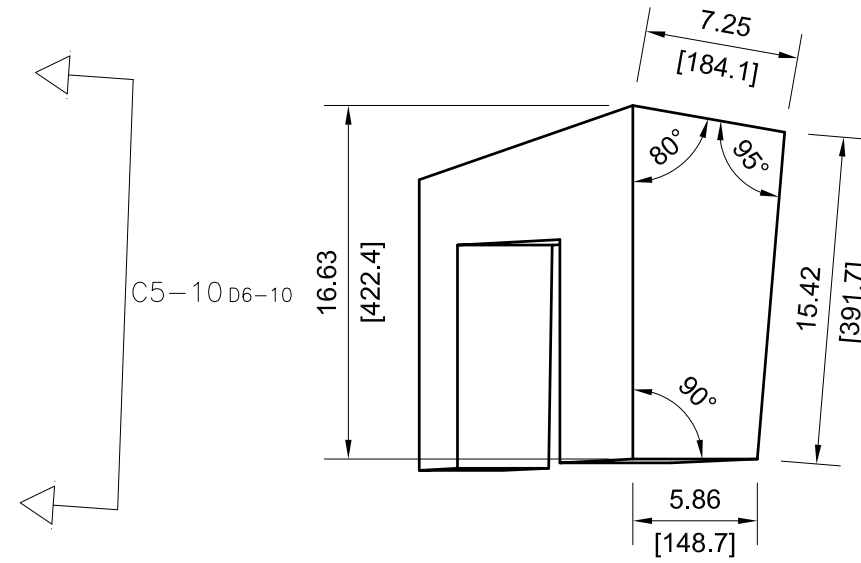

VIEW C5-10

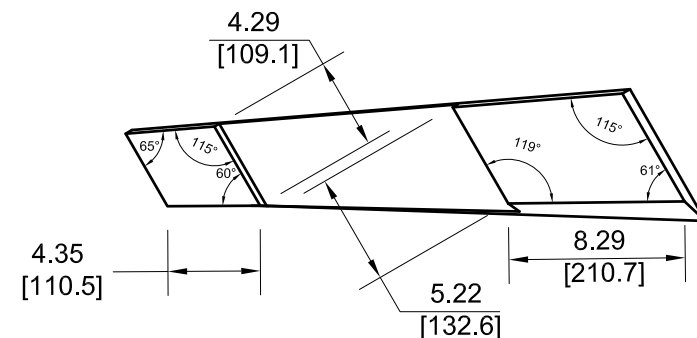

VIEW D7-10

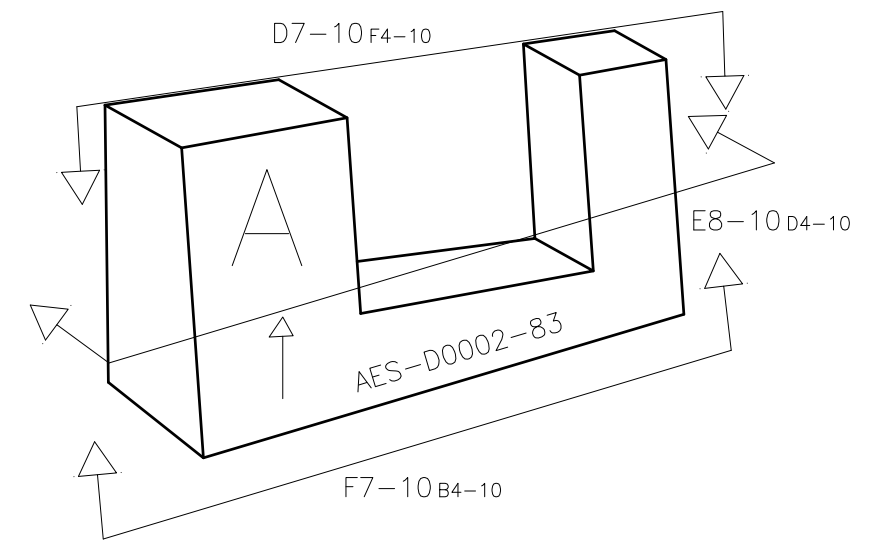

NOTE: ALL VIEWS TAKEN AS TRUE VIEWS PARALLEL TO SURFACE OF PART

	DRAWING NUMBER				
	AES-D0002				
SIZE	SCALE	SHEET	OF	REVISION	
A3	NONE	10	167	F	

85

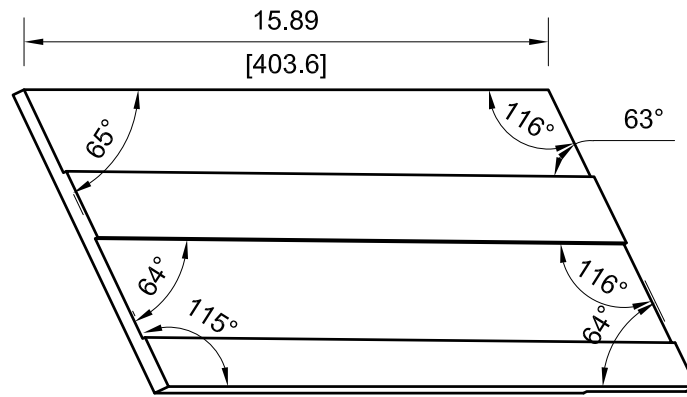

VIEW D8-11

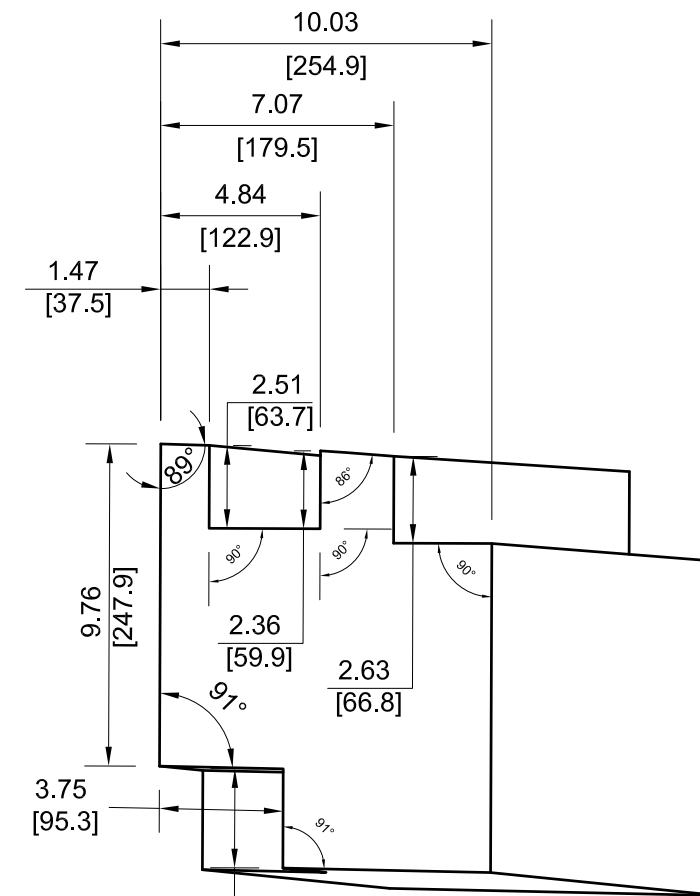

VIEW C4-11

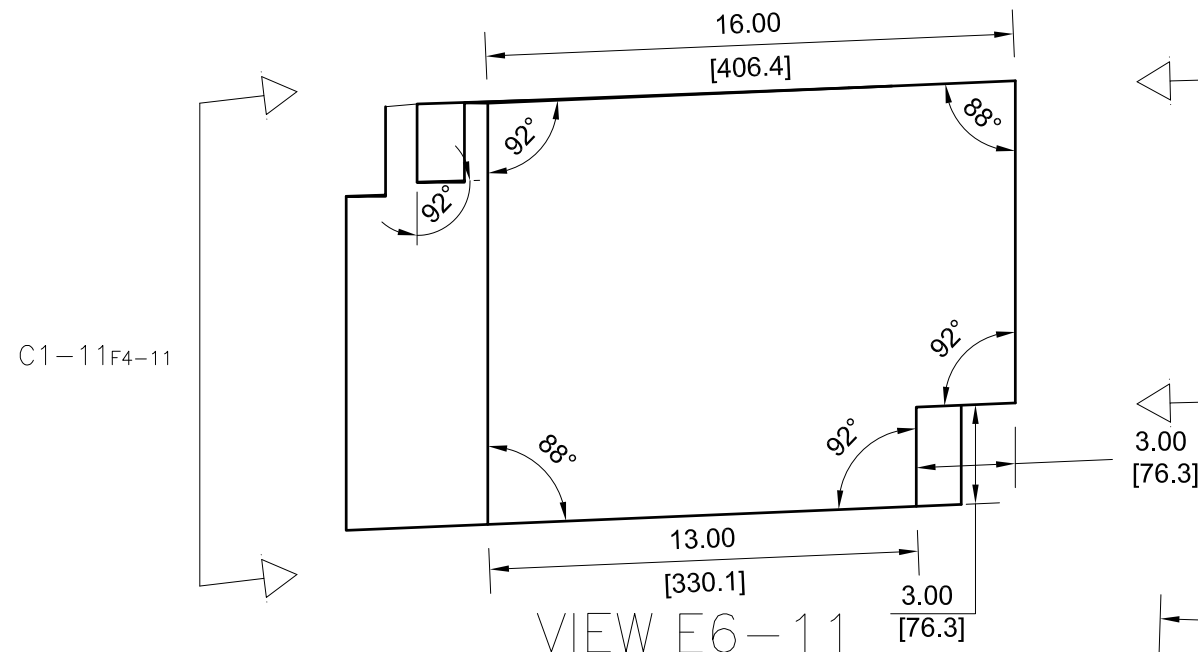

VIEW E6-11

C1-11F4-11

C4-11D6-11

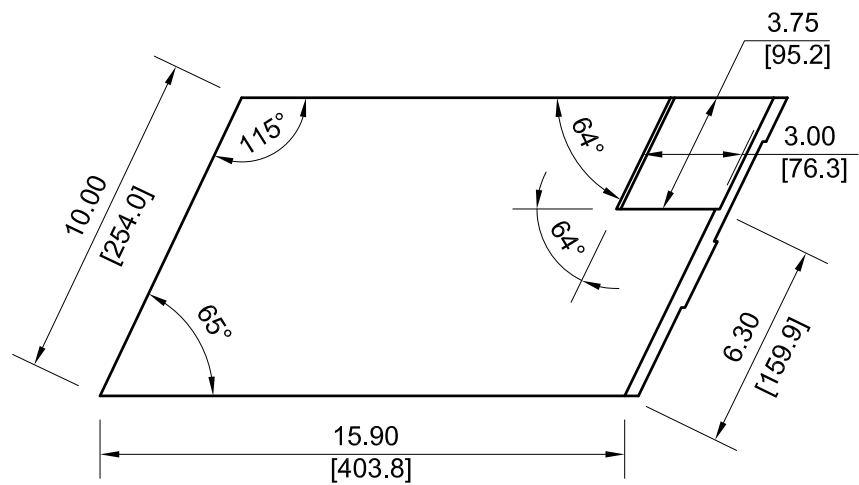

VIEW F7-11

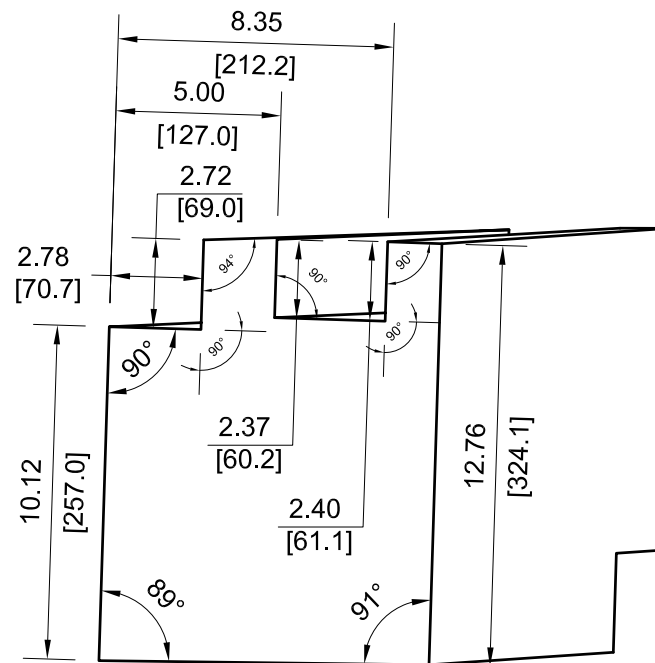

VIEW C1-11

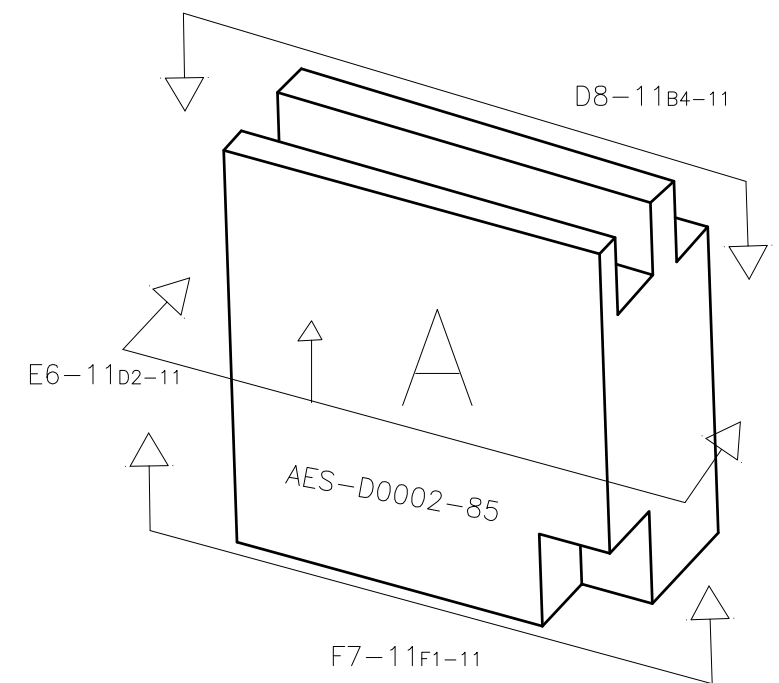

VIEW F7-11F1-11

NOTE: ALL VIEWS TAKEN AS TRUE VIEWS PARALLEL TO SURFACE OF PART

		DRAWING NUMBER			
		AES-D0002			
SIZE	SCALE	SHEET	OF	REVISION	
A3	NONE	11	167	F	

-87

SECTION VIEW B2-12

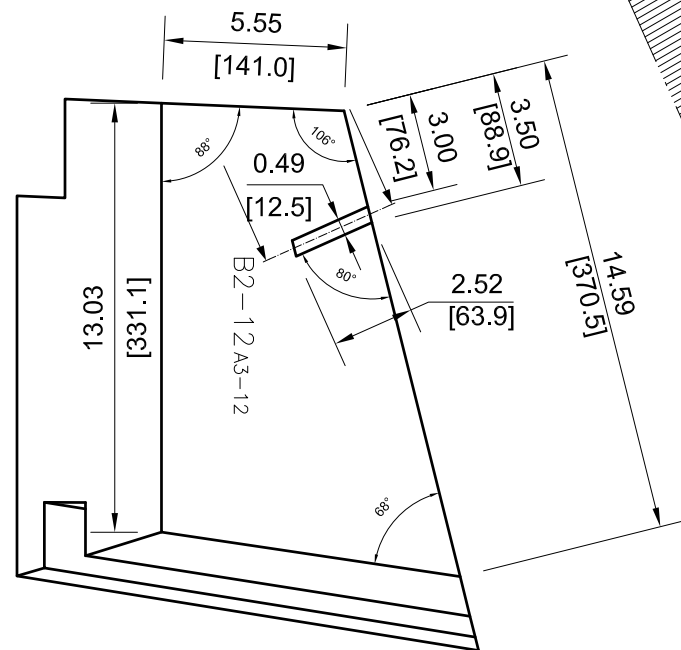
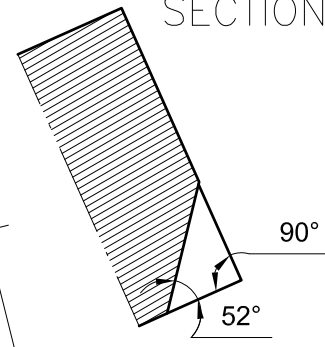

VIEW E3-12

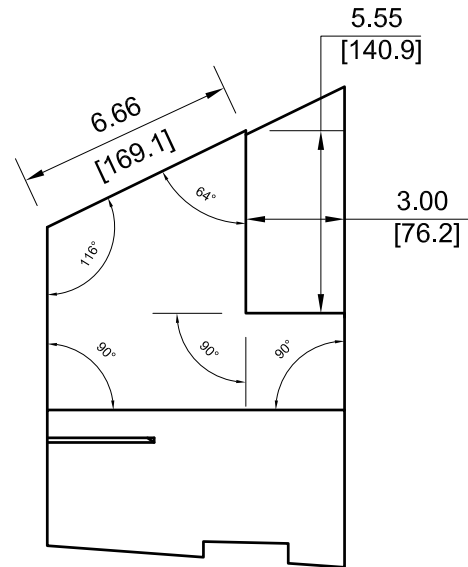

VIEW D7-12

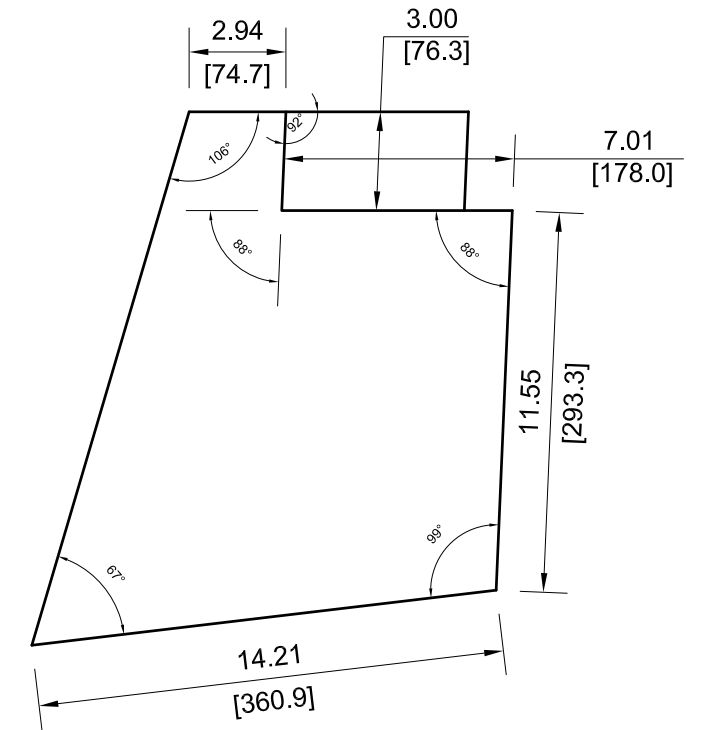

VIEW E5-12

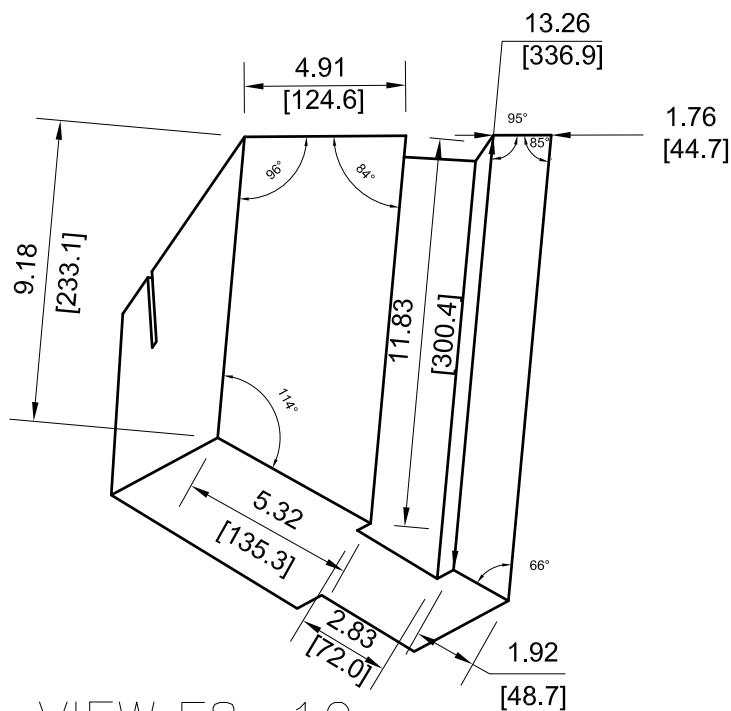

VIEW F8-12

E3-12 D1-12

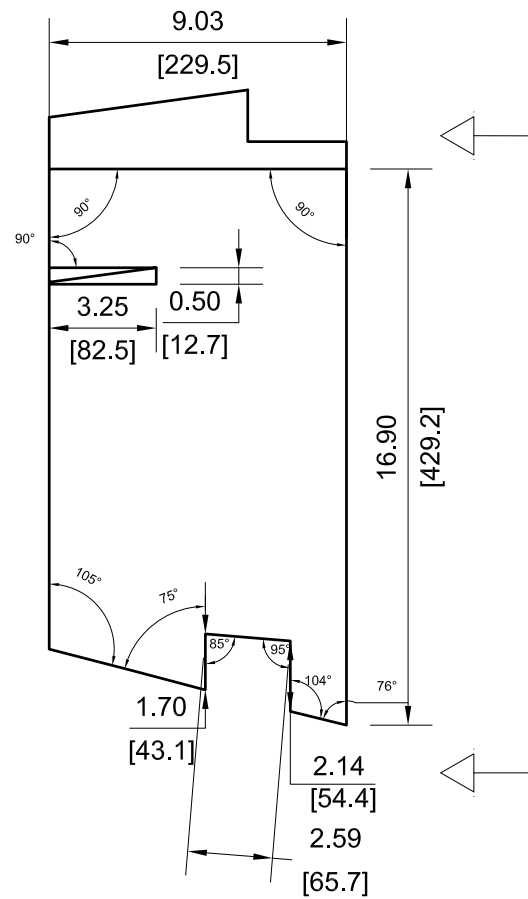

VIEW E6-12

E5-12 C7-12

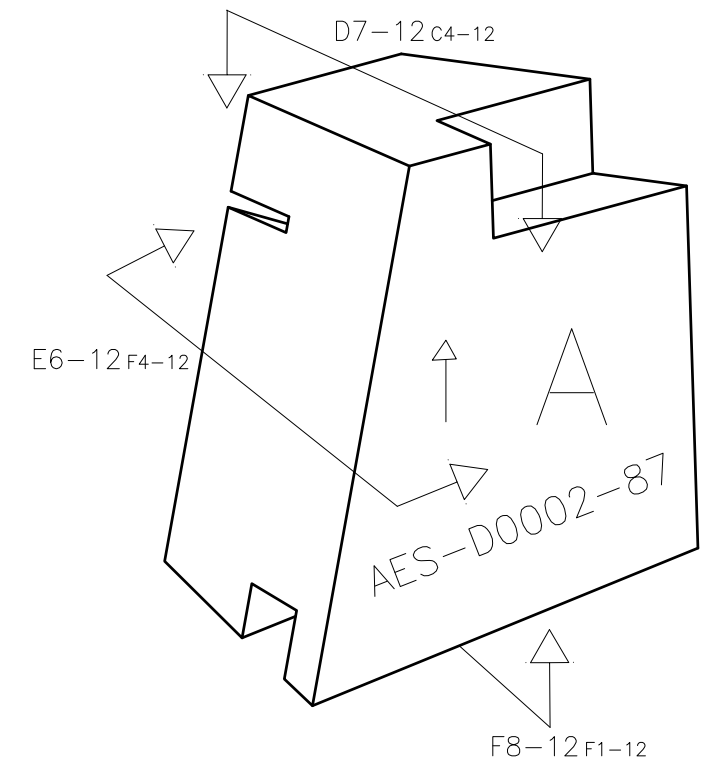

NOTE: ALL VIEWS TAKEN AS TRUE VIEWS PARALLEL TO SURFACE OF PART



DRAWING NUMBER					AES-D0002				
SIZE	SCALE	SHEET	OF	REVISION					
A3	NONE	12	167	F					

89

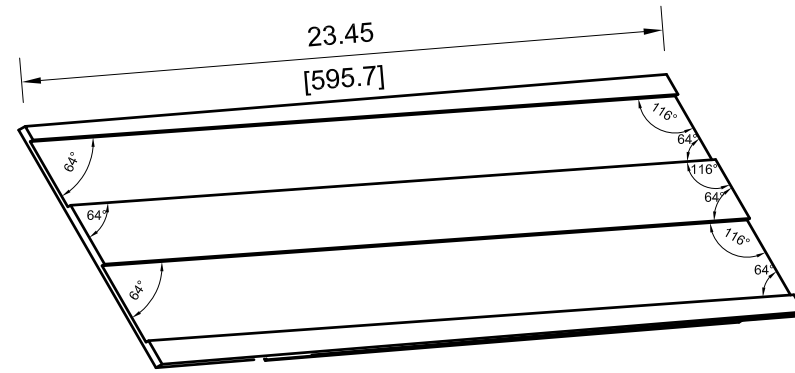

VIEW D8-13

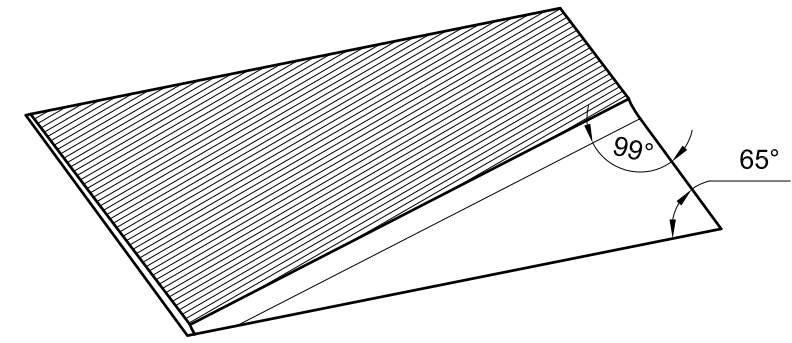

SECTION VIEW C5-13

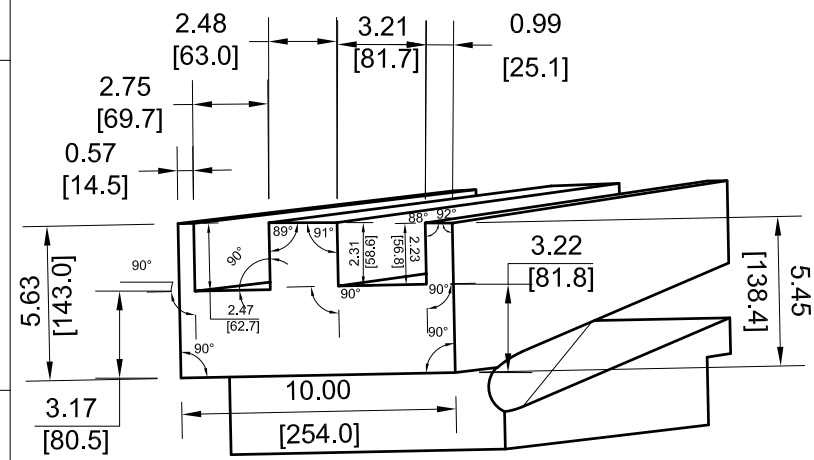

VIEW C3-13

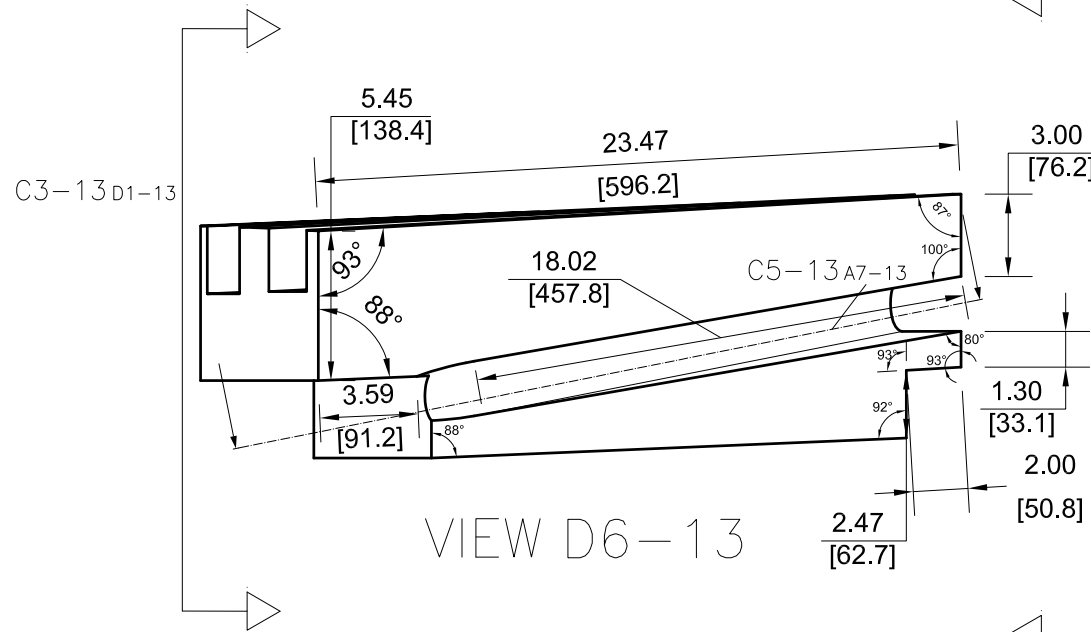

VIEW D6-13

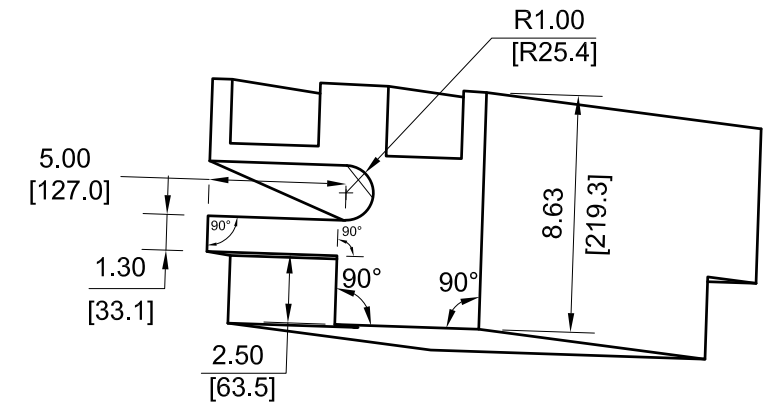

VIEW C6-13

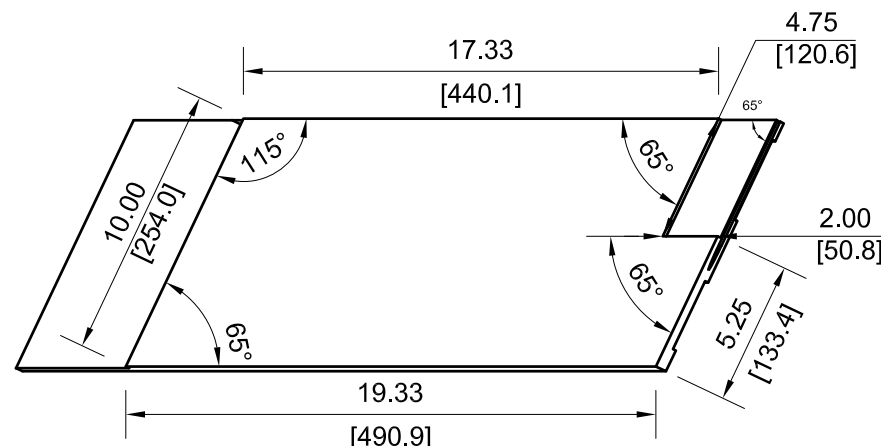

VIEW F8-13

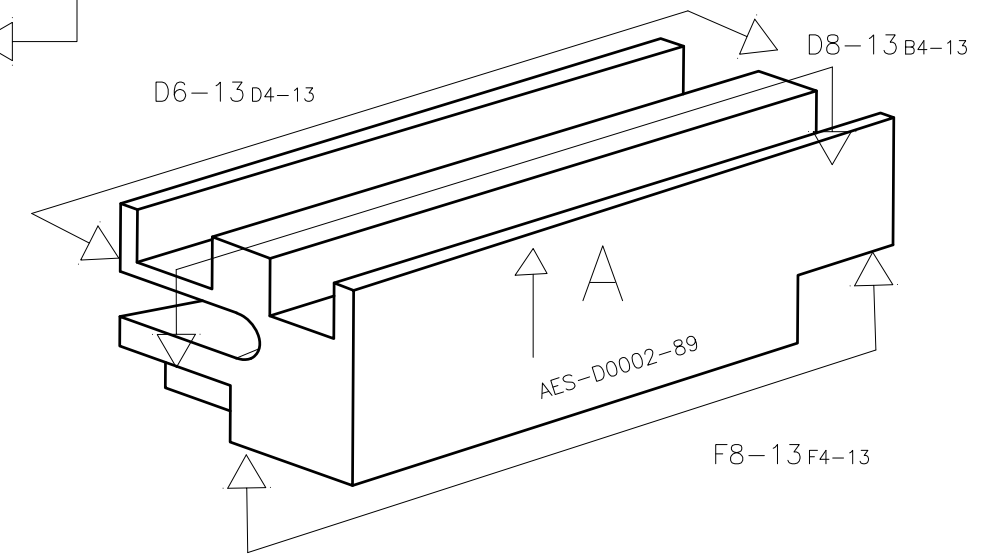

NOTE: ALL VIEWS TAKEN AS TRUE VIEWS PARALLEL TO SURFACE OF PART

		DRAWING NUMBER			
		AES-D0002			
SIZE	SCALE	SHEET	OF	REVISION	
A3	NONE	13	167	F	

91

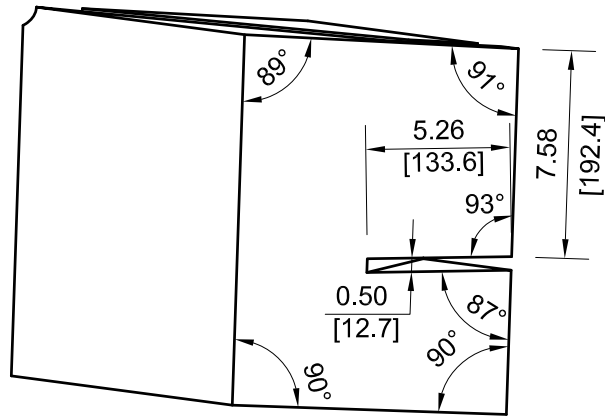
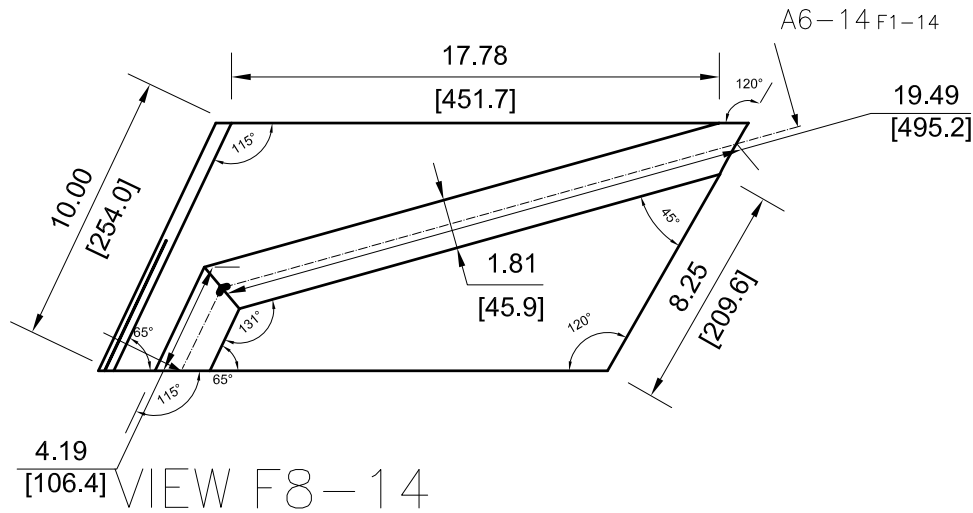

VIEW C3-14

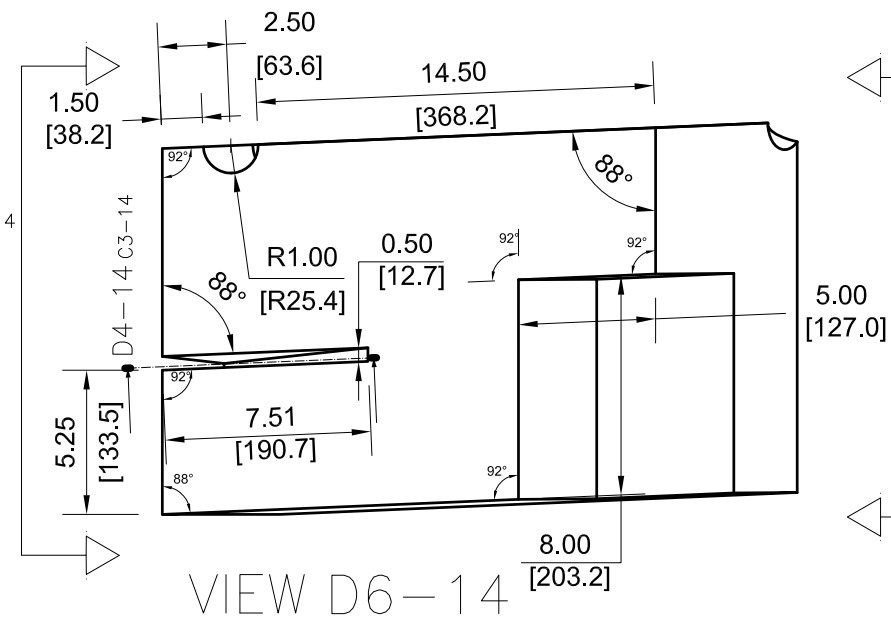

VIEW D6-14

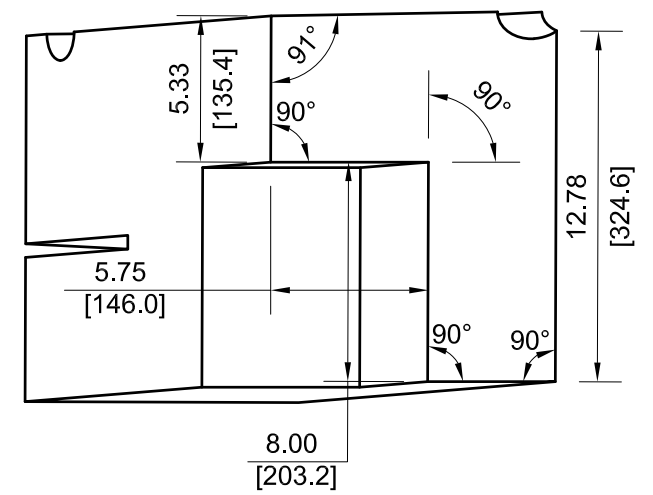

VIEW C6-14

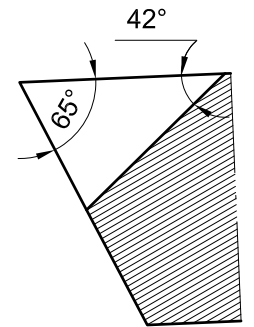

SECTION VIEW D4-14

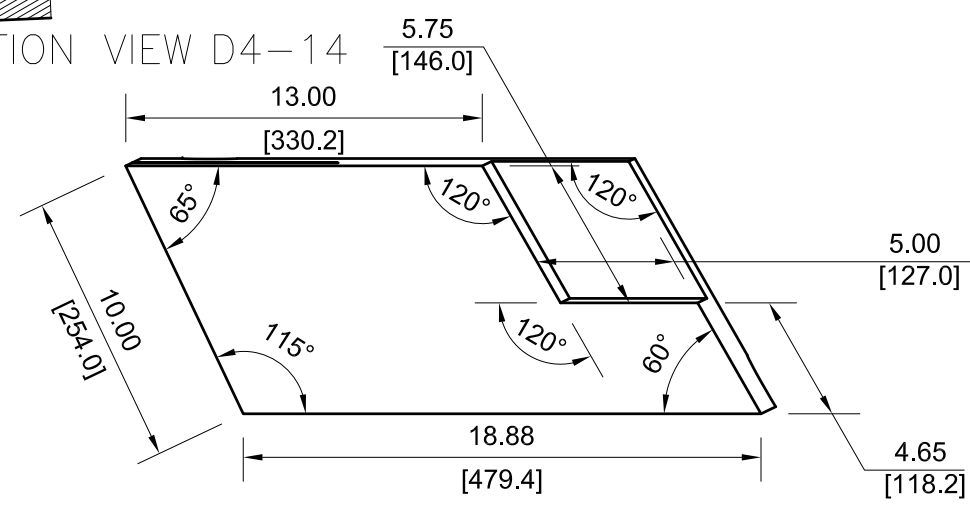

VIEW D8-14

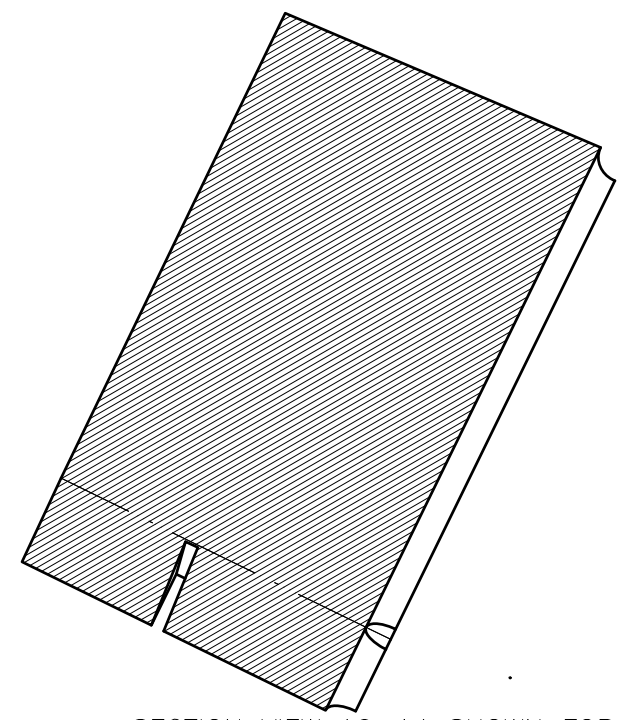
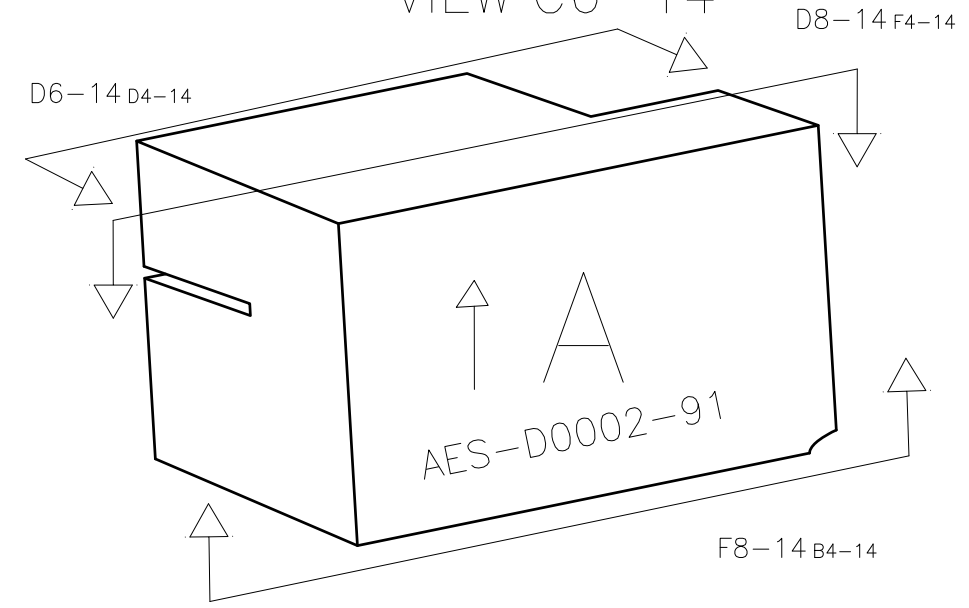

SECTION VIEW A6-14 SHOWN FOR CLARITY PURPOSES

NOTE: ALL VIEWS TAKEN AS TRUE VIEWS PARALLEL TO SURFACE OF PART

DRAWING NUMBER		AES-D0002		
SIZE	SCALE	SHEET	OF	REVISION
A3	NONE	14	167	F

-93

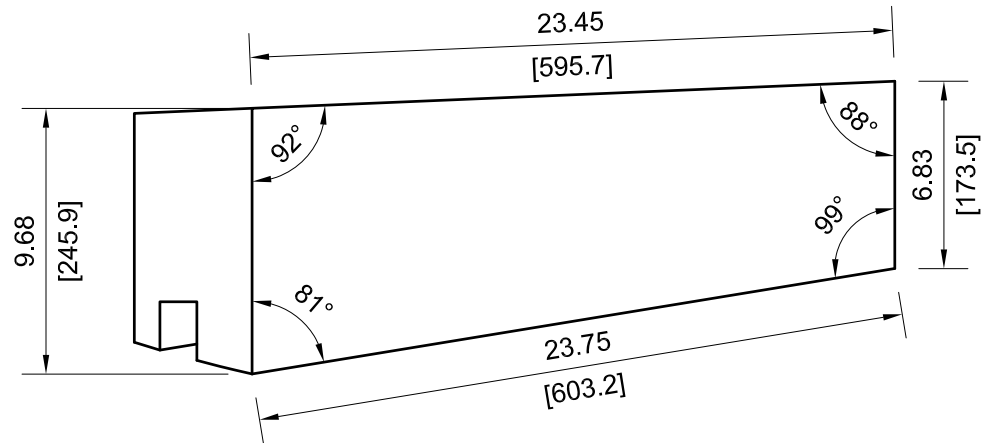

VIEW E8-15

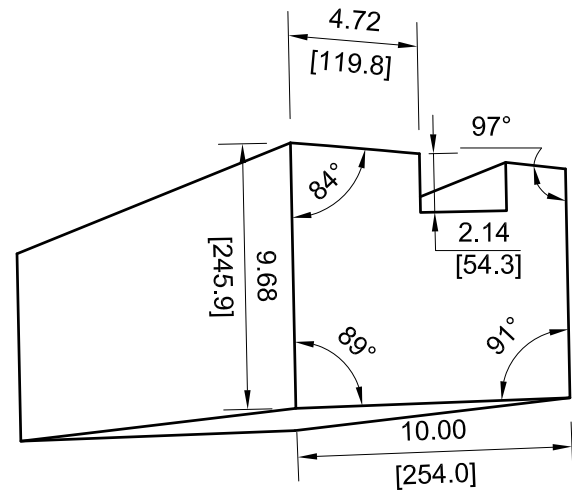

VIEW C3-15

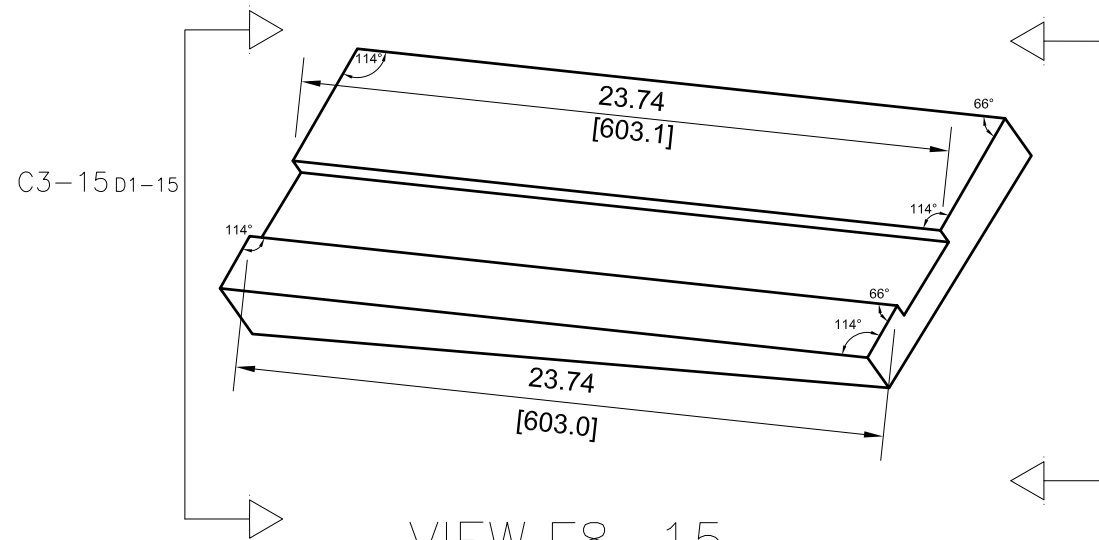

VIEW F8-15

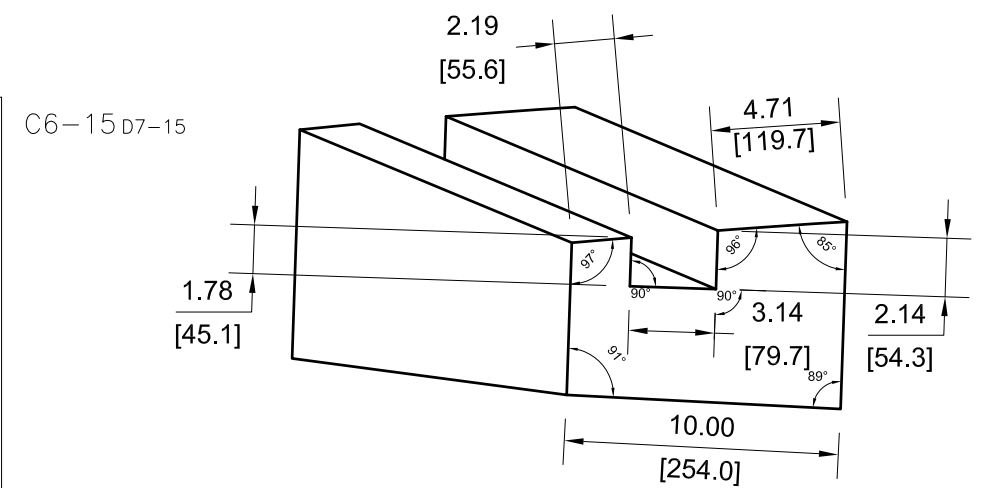

VIEW C6-15

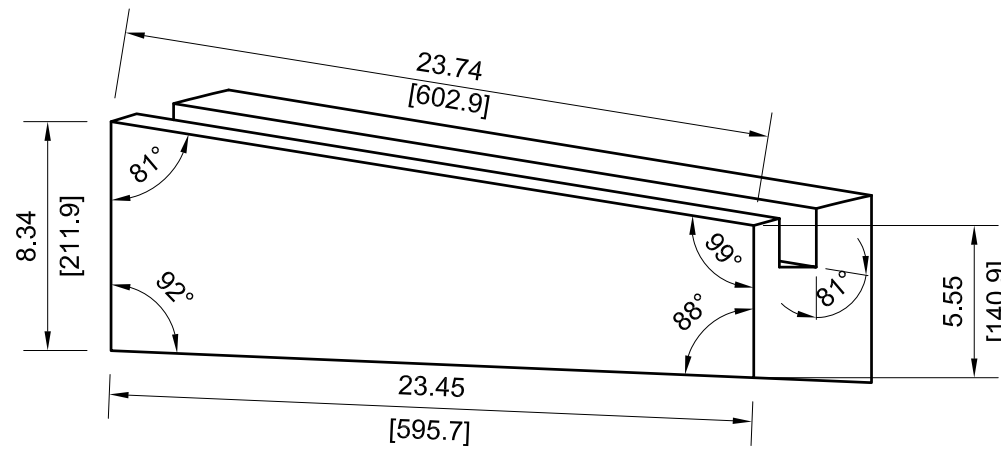

VIEW E6-15

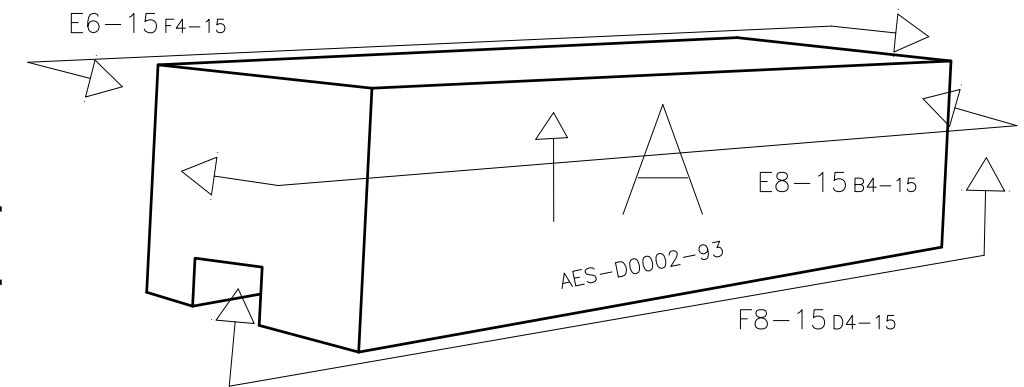

NOTE: ALL VIEWS TAKEN AS TRUE VIEWS PARALLEL TO SURFACE OF PART

		DRAWING NUMBER			
		AES-D0002			
SIZE	SCALE	SHEET	OF	REVISION	
A3	NONE	15	167	F	

95

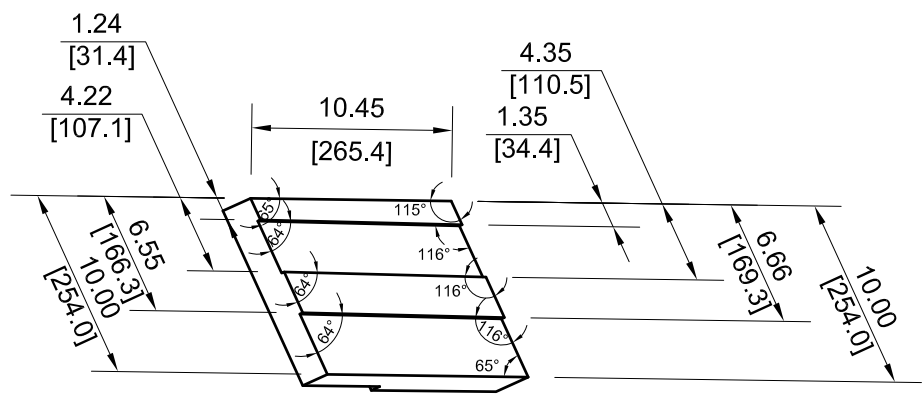

VIEW D7-16

C3-16 F1-16

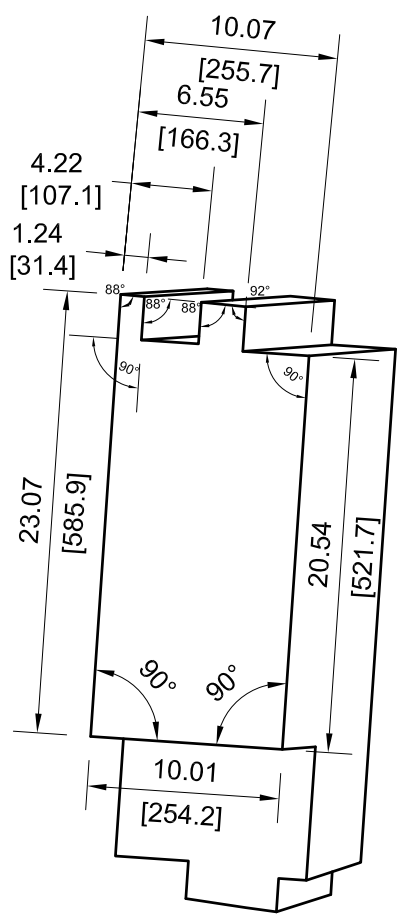

VIEW E6-16

C6-16 D7-16

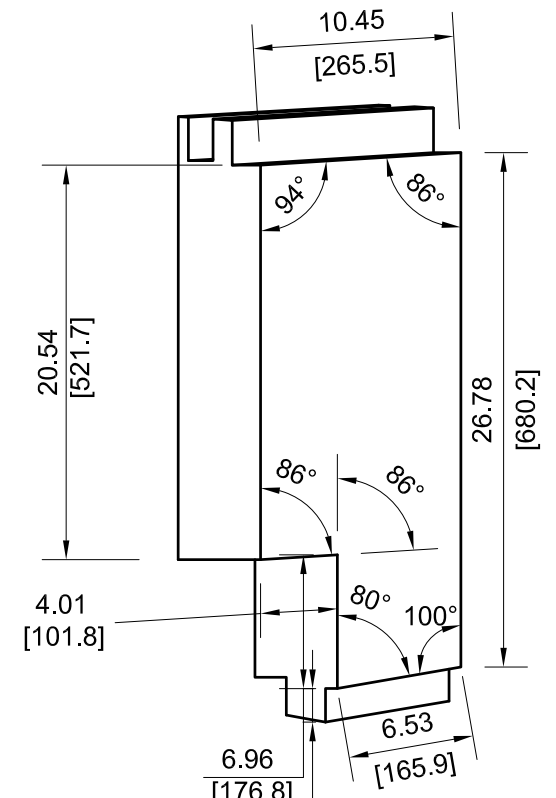

VIEW C6-16

D7-16 C1-16

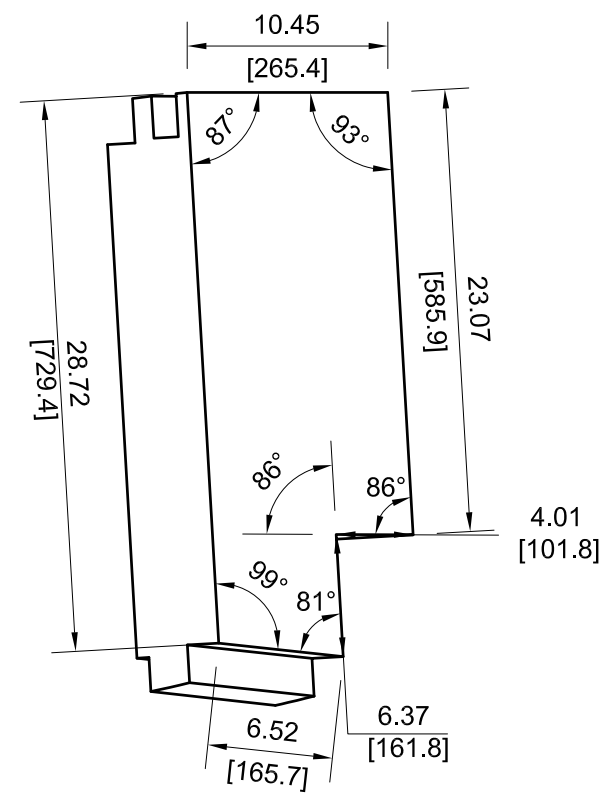

VIEW C3-16

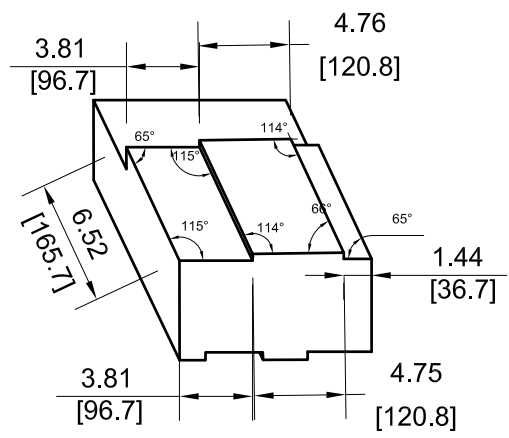

VIEW F8-16

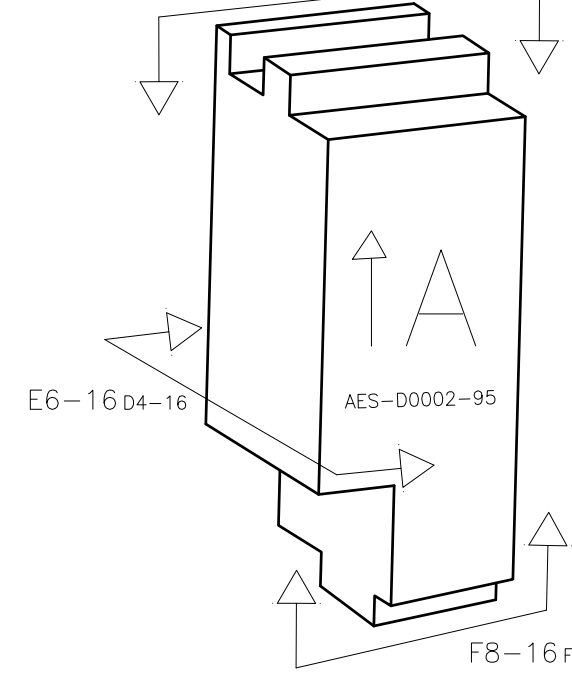

F8-16 F4-16

NOTE: ALL VIEWS TAKEN AS TRUE VIEWS PARALLEL TO SURFACE OF PART

	DRAWING NUMBER				
	AES-D0002				
SIZE	SCALE	SHEET	OF	REVISION	
A3	NONE	16	167	F	

99

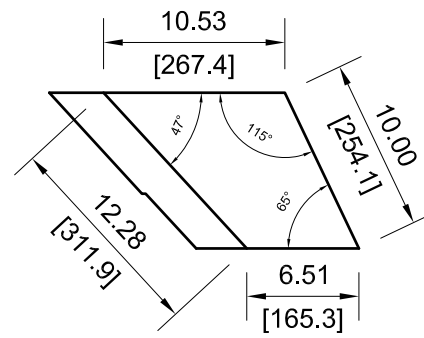

VIEW D7-18

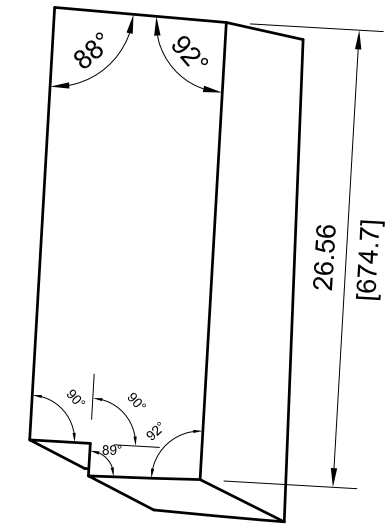

VIEW C6-18

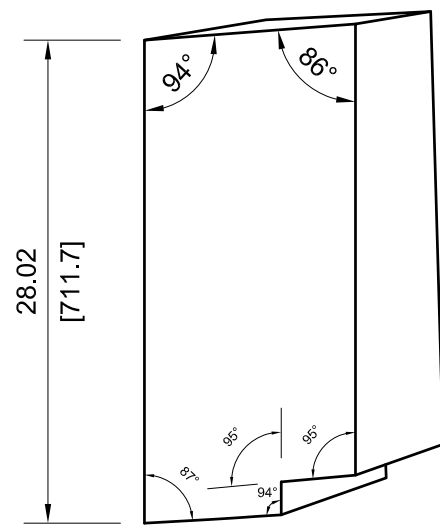

VIEW C3-18

C3-18 D1-18

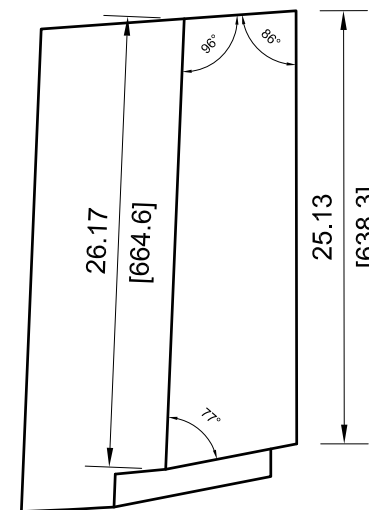

VIEW E8-18



C6-18 D7-18

D7-18 B4-18

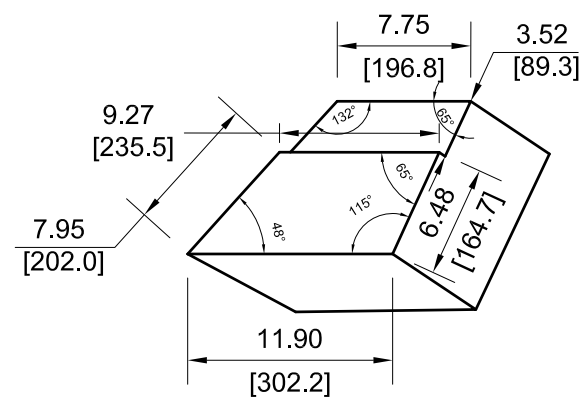
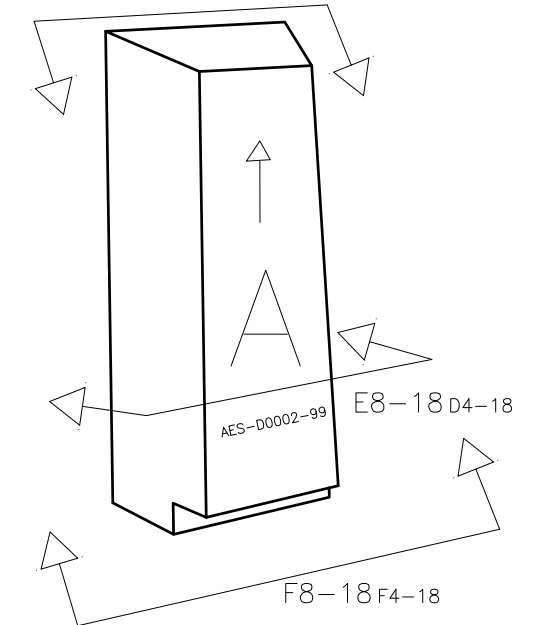

VIEW F8-18

NOTE: ALL VIEWS TAKEN AS TRUE VIEWS PARALLEL TO SURFACE OF PART

	DRAWING NUMBER				
	AES-D0002				
SIZE	SCALE	SHEET	OF	REVISION	
A3	NONE	18	167	F	

-101

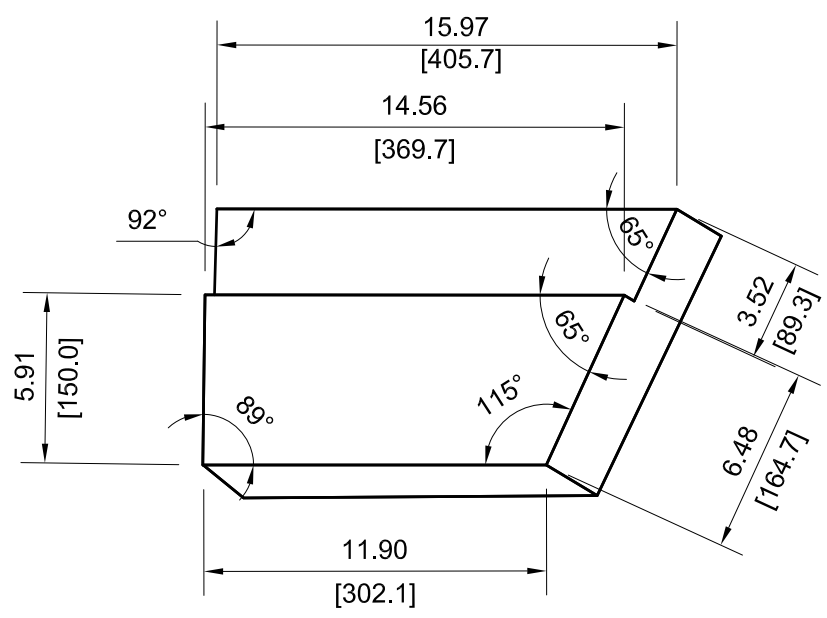

VIEW 2F4-19

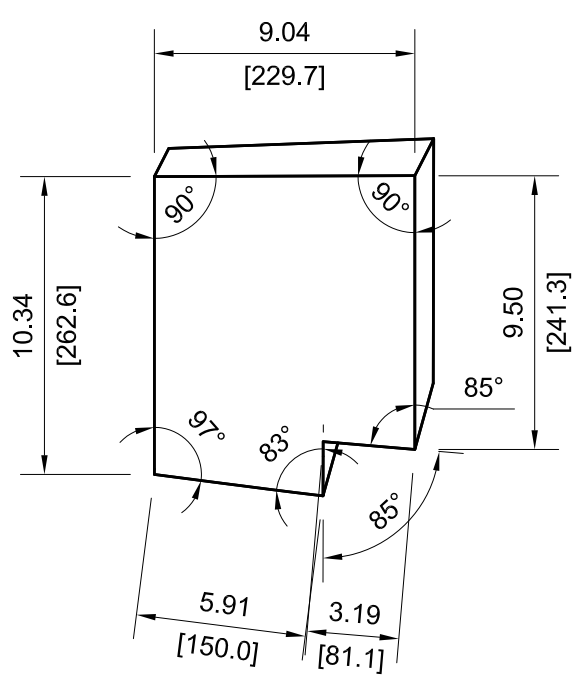
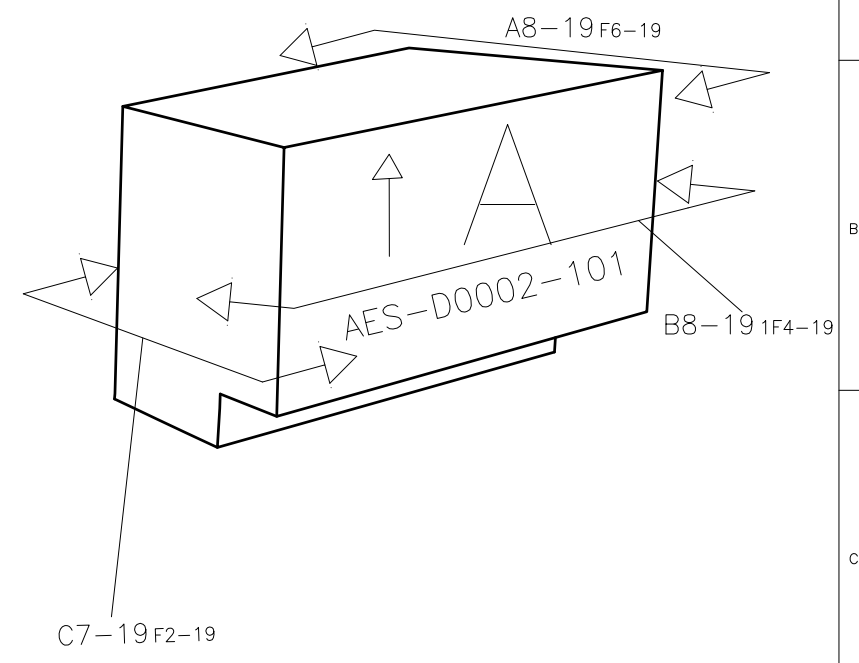

VIEW C7-19

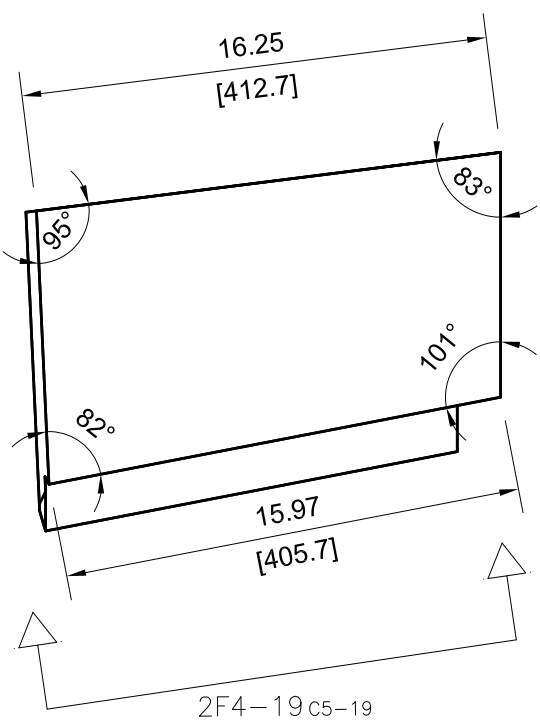

VIEW B8-19

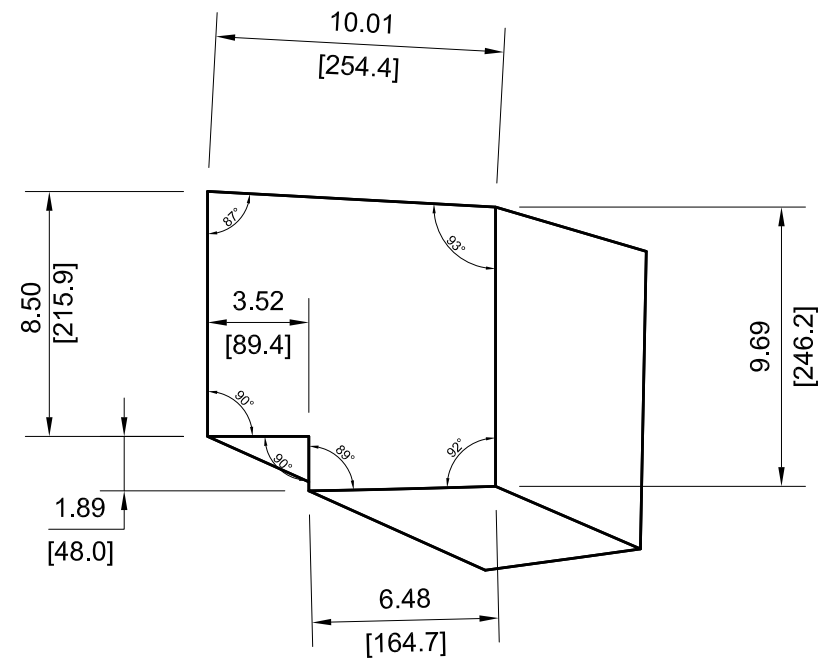

VIEW A8-19

NOTE: ALL VIEWS TAKEN AS TRUE VIEWS PARALLEL TO SURFACE OF PART

		DRAWING NUMBER			
		AES-D0002			
SIZE	SCALE	SHEET	OF	REVISION	
A3	NONE	19	167	F	

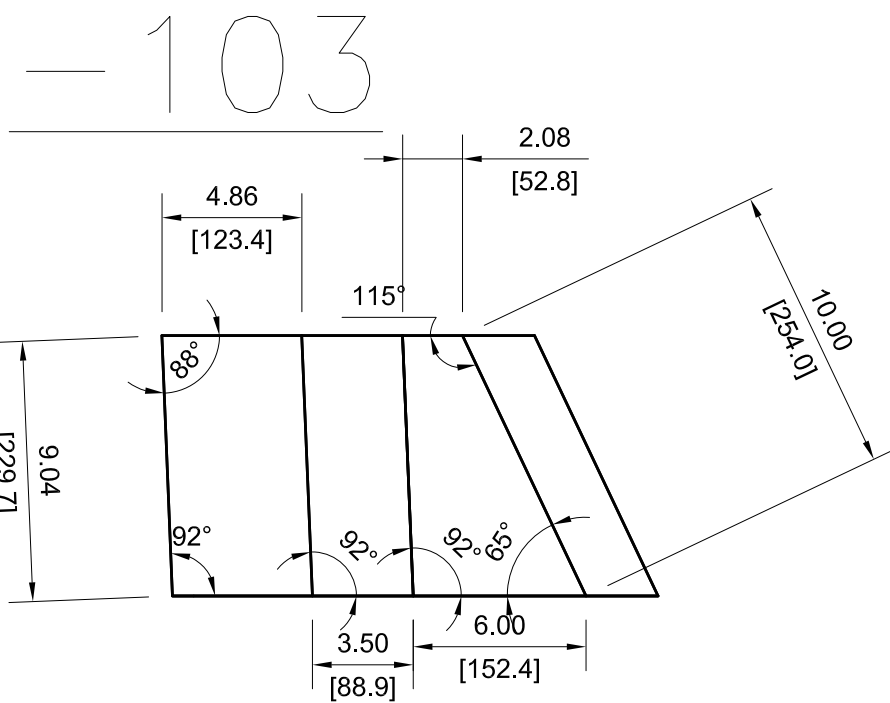

VIEW D4-20

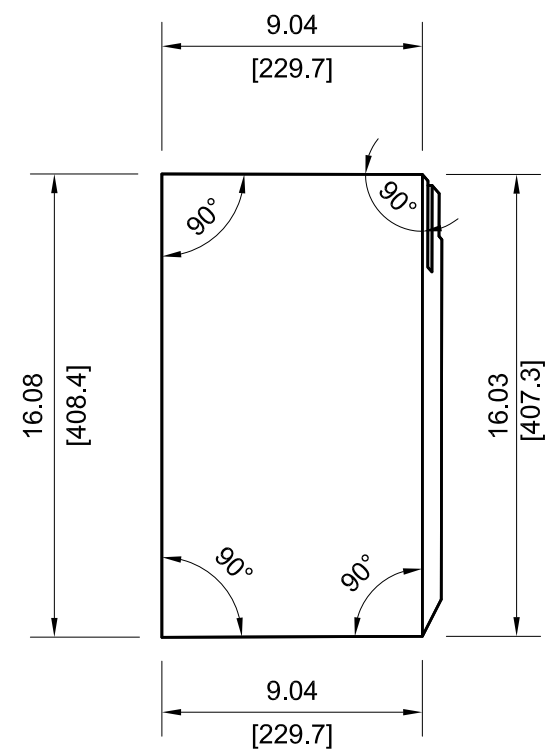
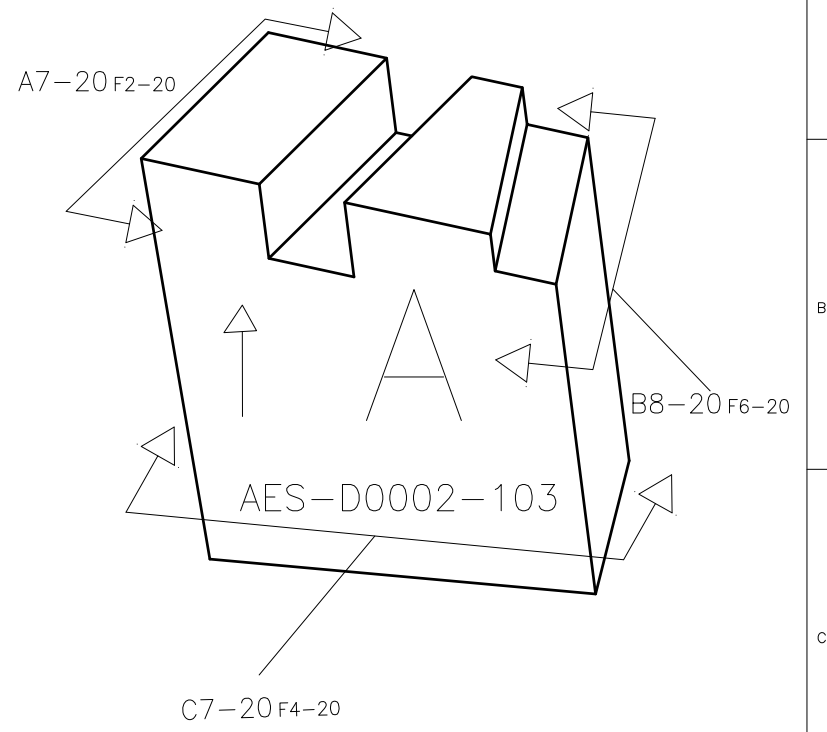

VIEW A7-20

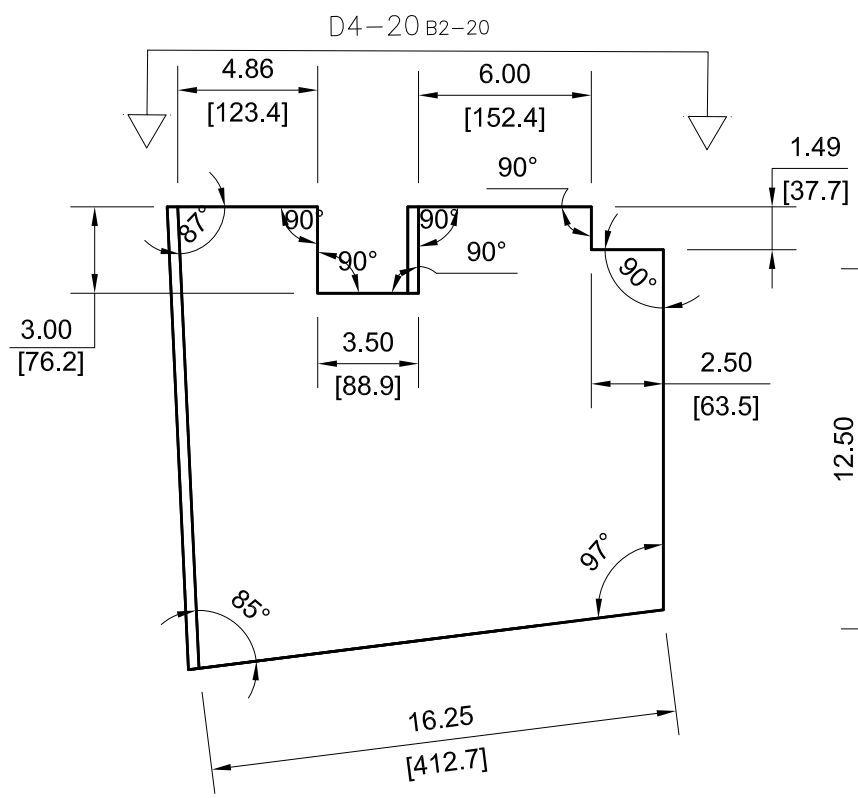

VIEW C7-20

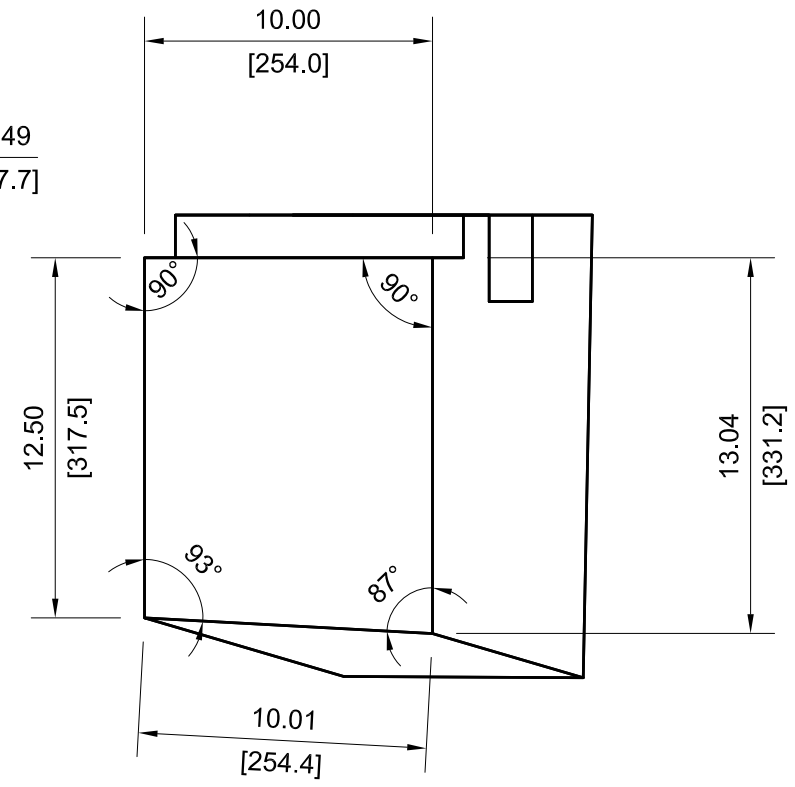

VIEW B8-20

NOTE: ALL VIEWS TAKEN AS TRUE VIEWS PARALLEL TO SURFACE OF PART

		DRAWING NUMBER			
		AES-D0002			
SIZE	SCALE	SHEET	OF	REVISION	
A3	NONE	20	167	F	

-105

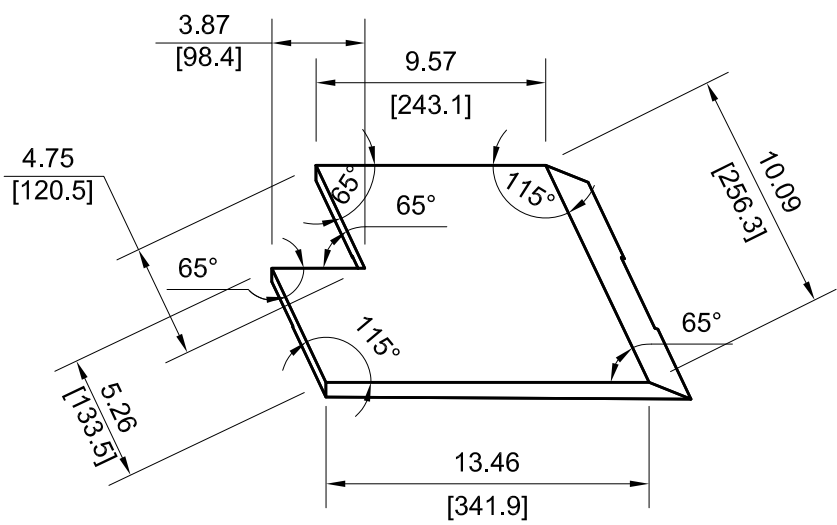

VIEW D4-21

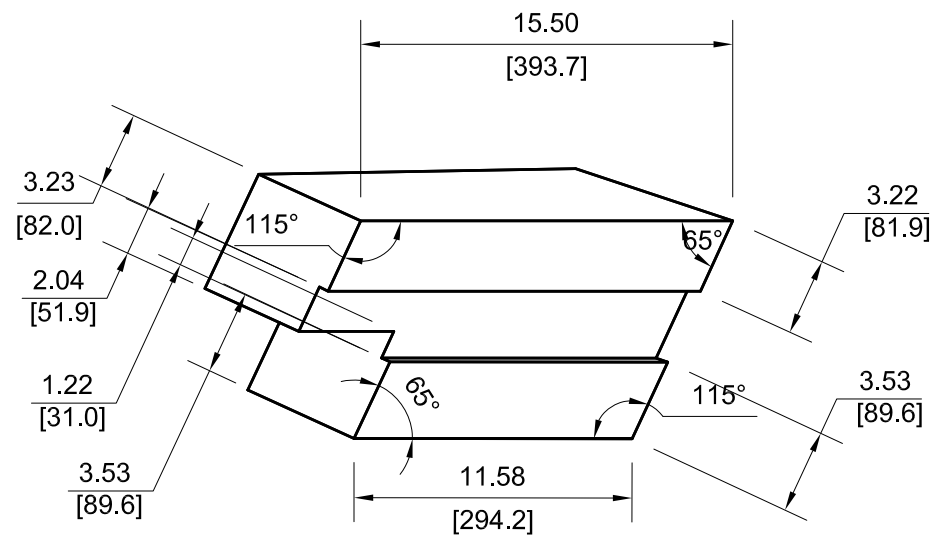

VIEW F4-21

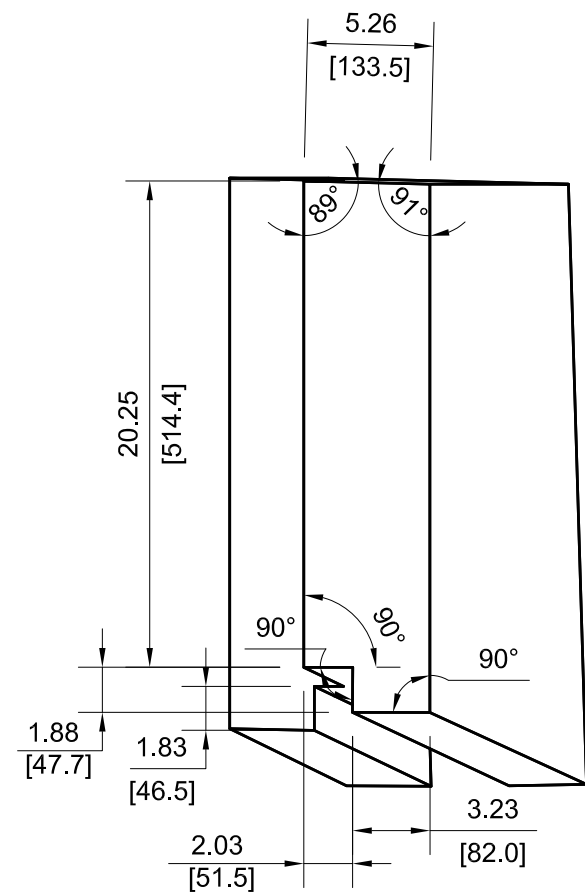
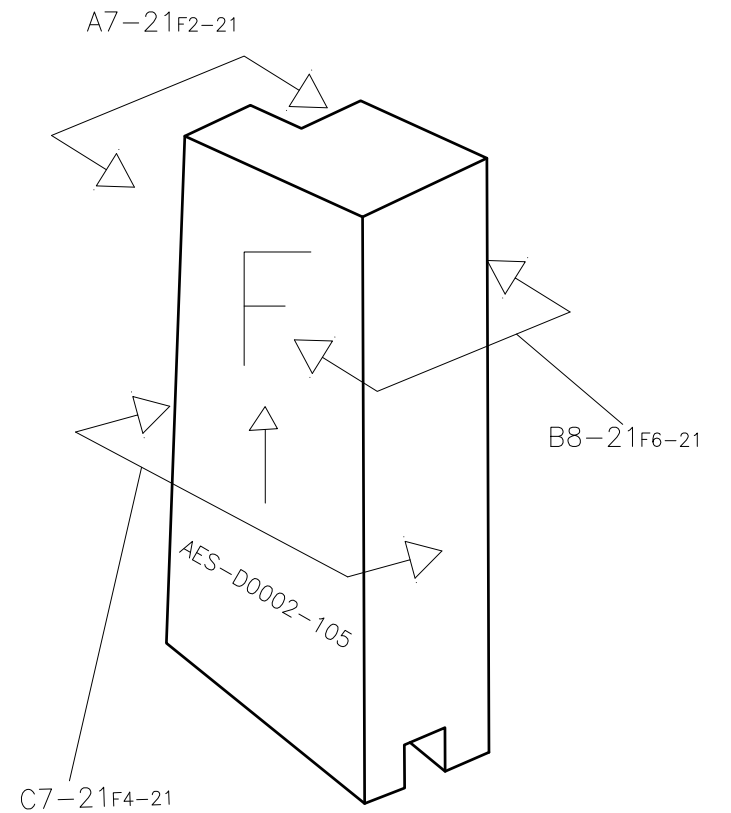

VIEW A7-21

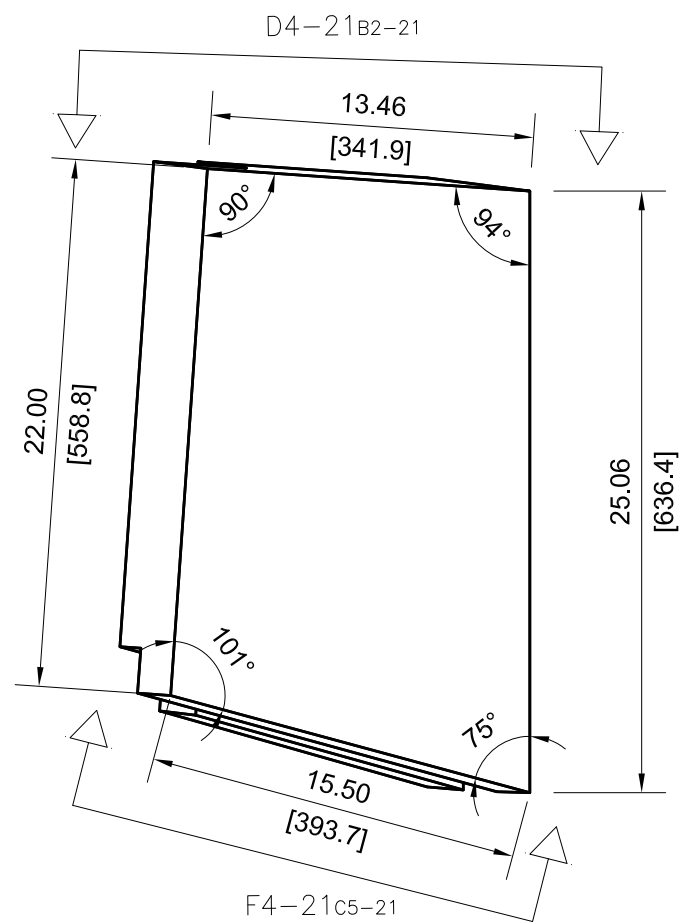

VIEW C7-21

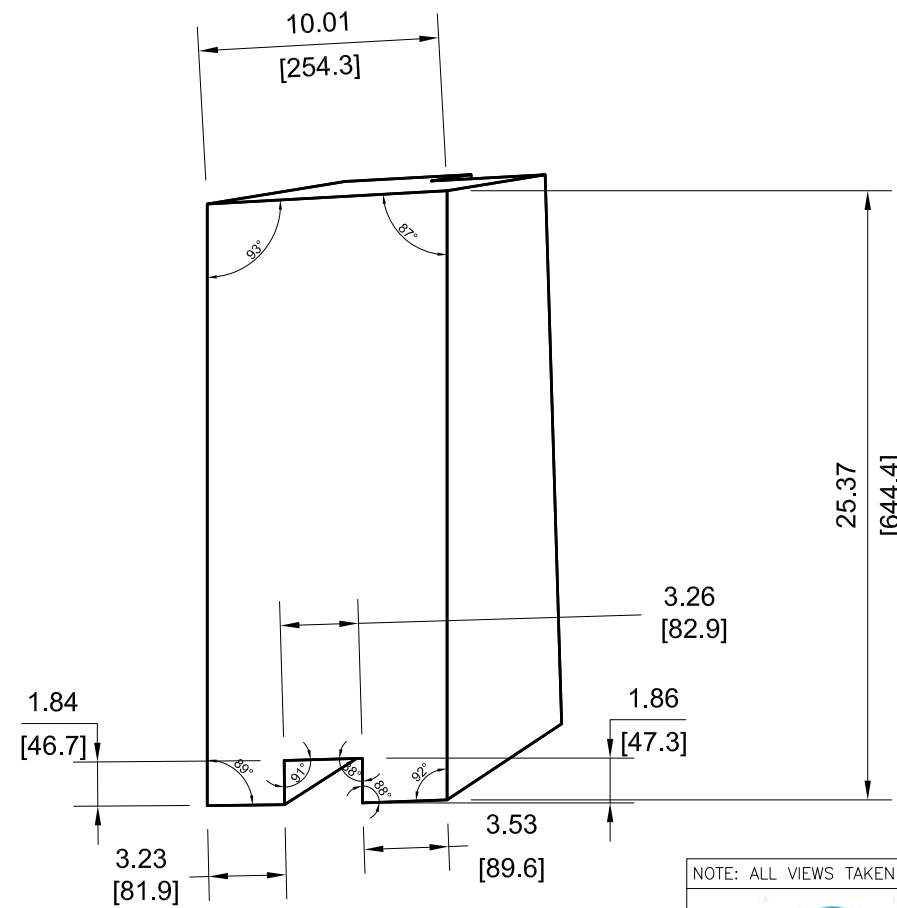

VIEW B8-21

NOTE: ALL VIEWS TAKEN AS TRUE VIEWS PARALLEL TO SURFACE OF PART

		DRAWING NUMBER			
		AES-D0002			
SIZE	SCALE	SHEET	OF	REVISION	
A3	NONE	21	167	F	

-107

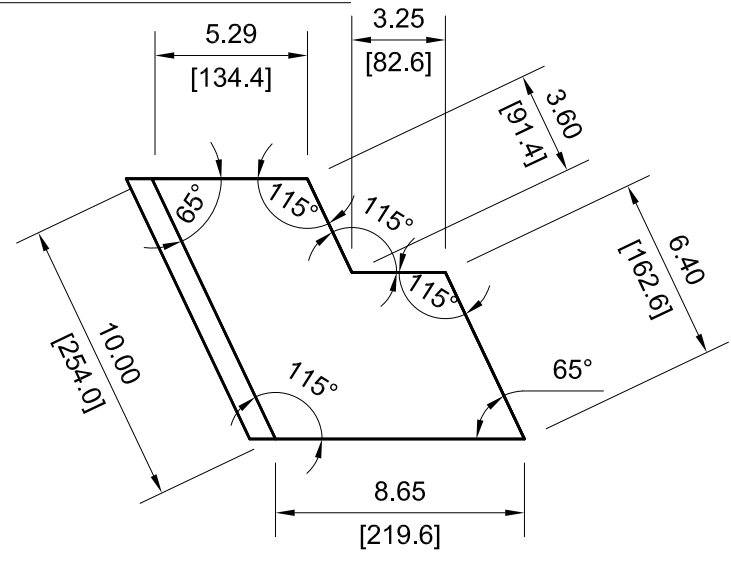

VIEW D4-22

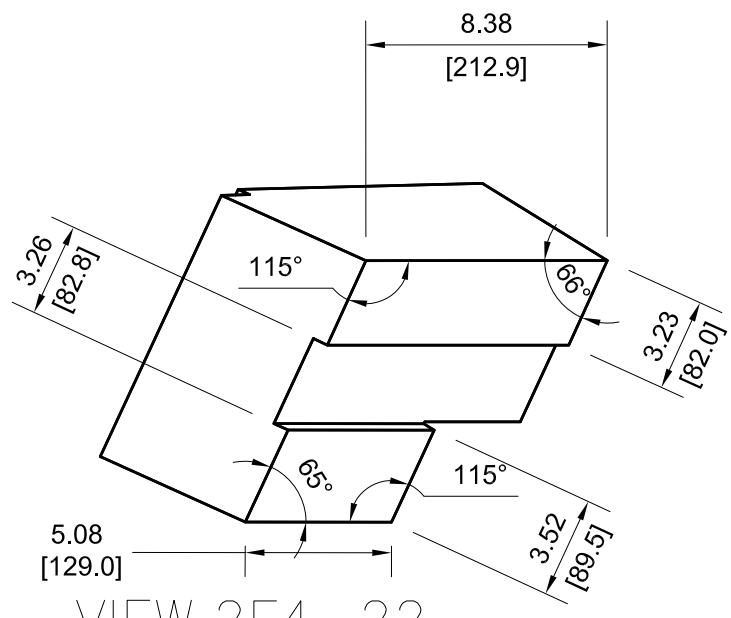

VIEW 2F4-22

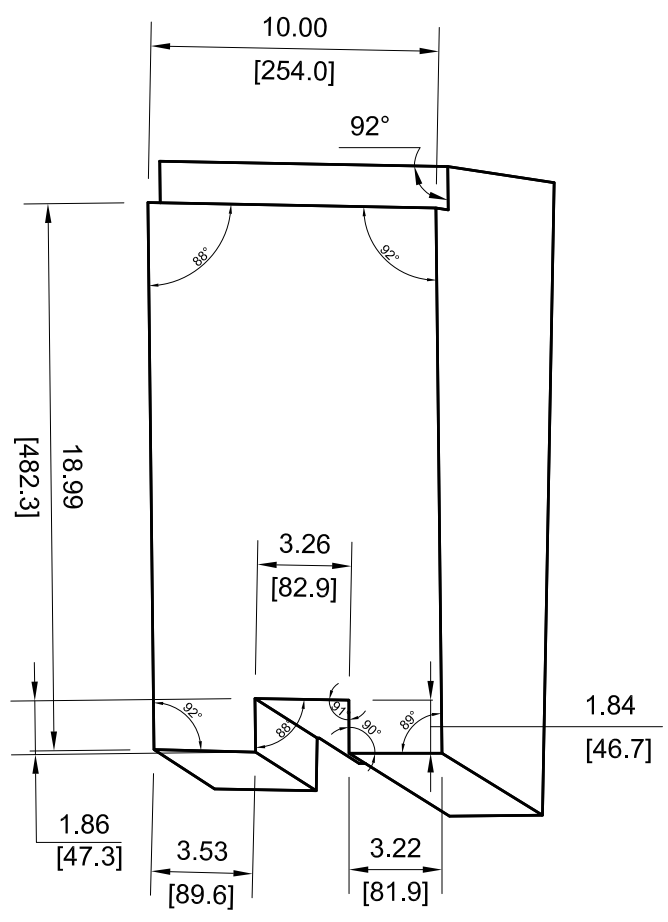
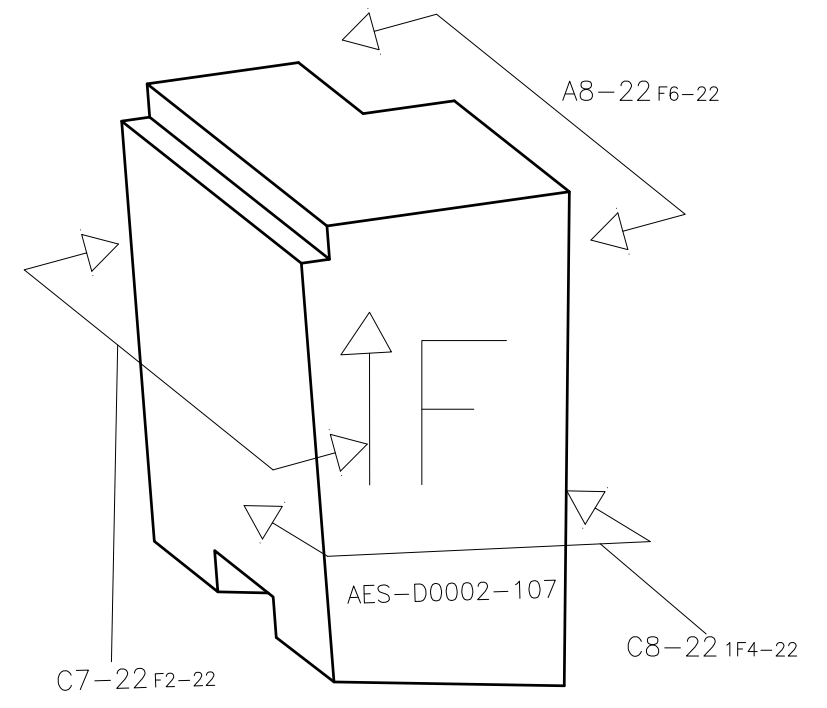

VIEW C7-22

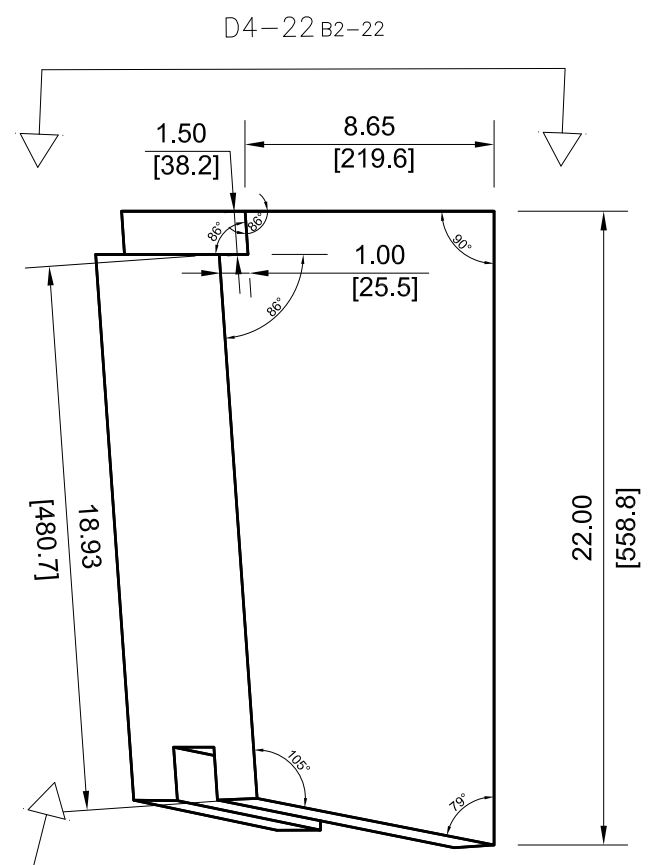

VIEW C8-22

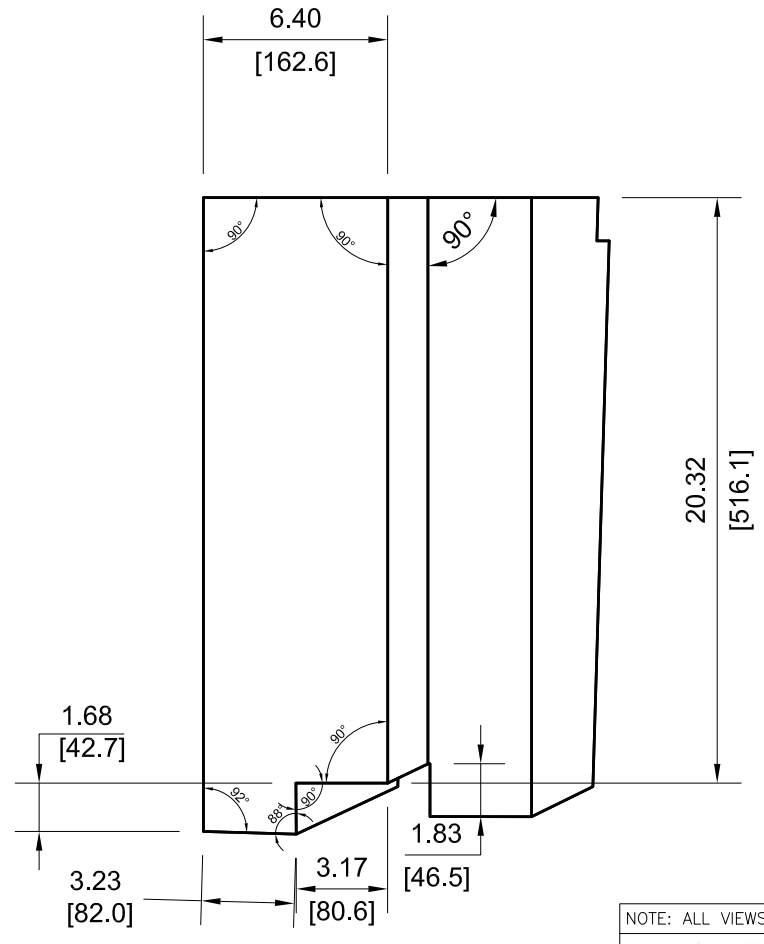

VIEW A8-22

NOTE: ALL VIEWS TAKEN AS TRUE VIEWS PARALLEL TO SURFACE OF PART

		DRAWING NUMBER			
		AES-D0002			
SIZE	SCALE	SHEET	OF	REVISION	
A3	NONE	22	167	F	

109

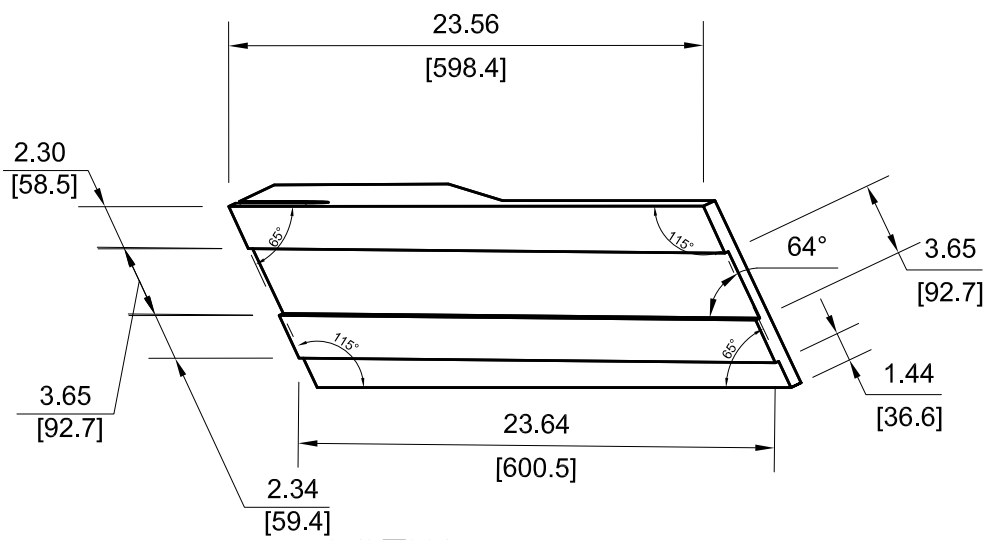

VIEW D4-23

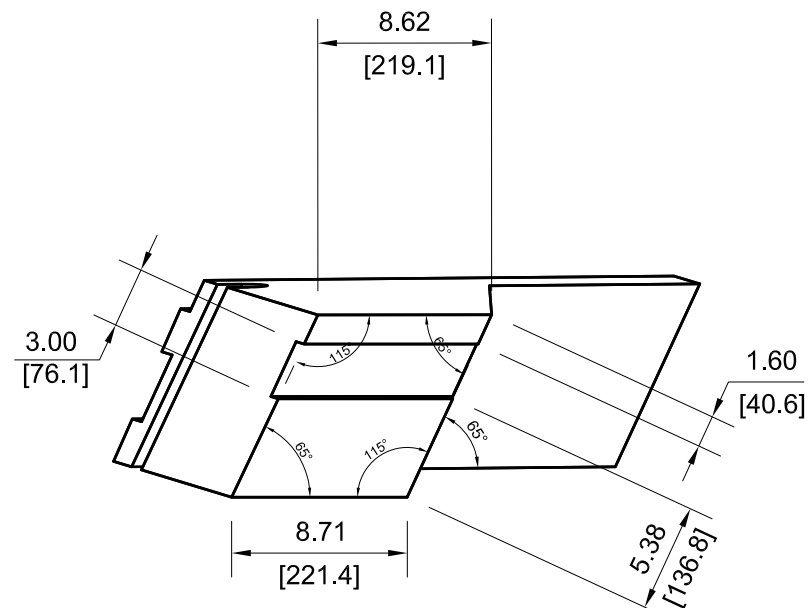

VIEW F4-23

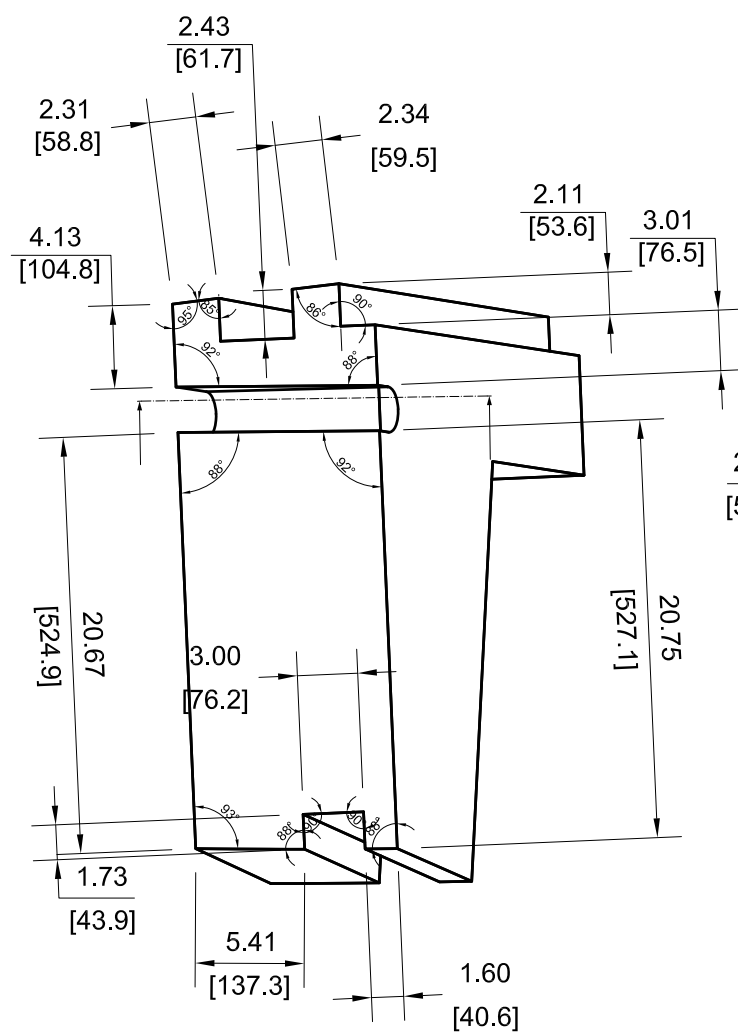
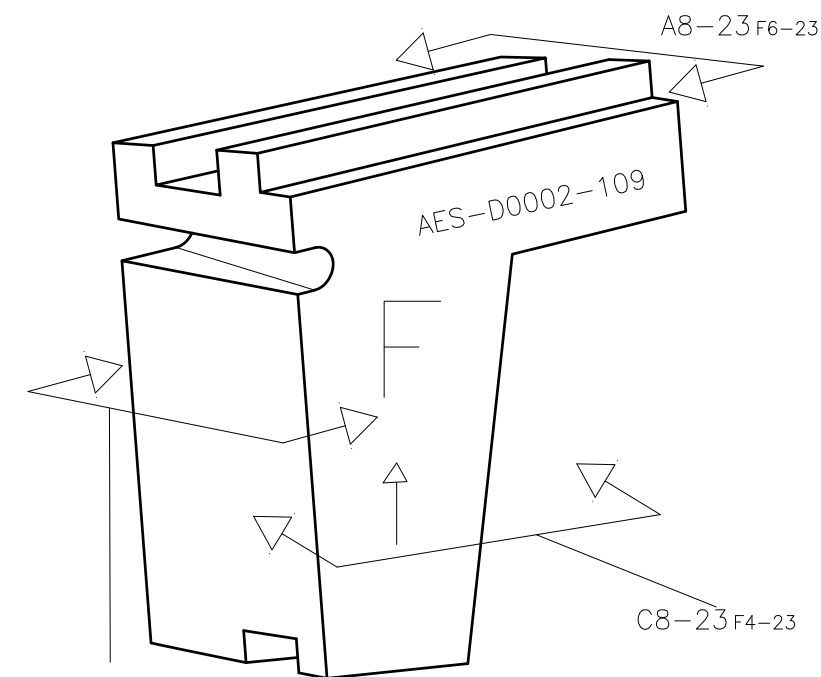

VIEW C7-23

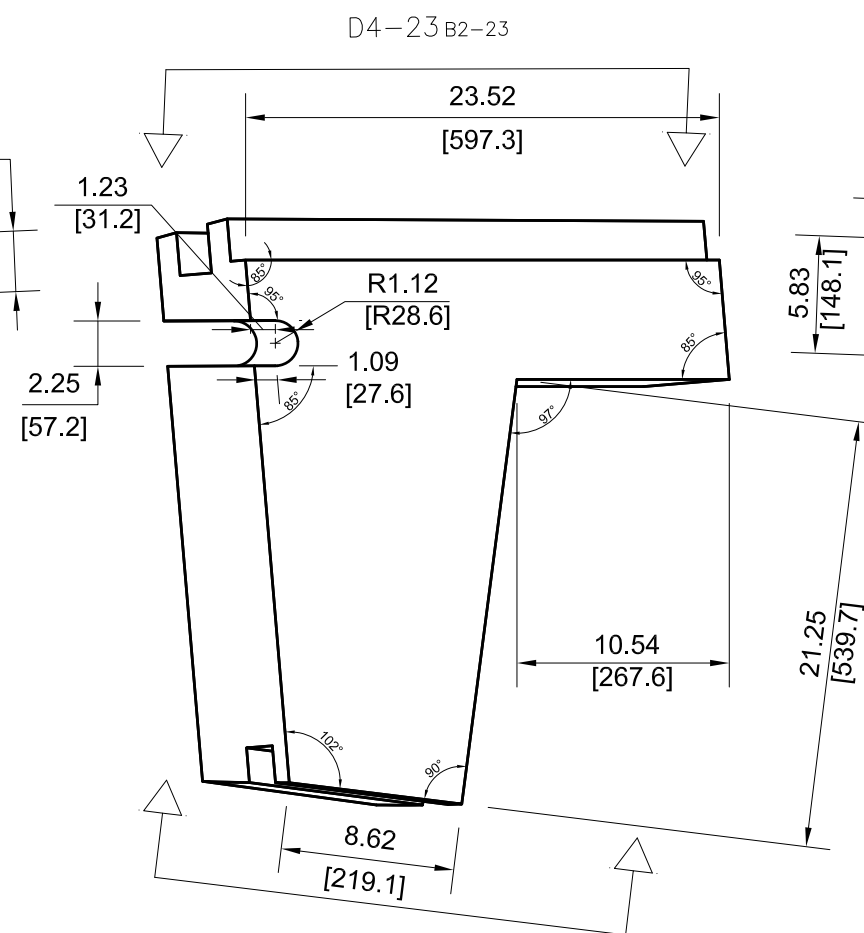

VIEW C8-23

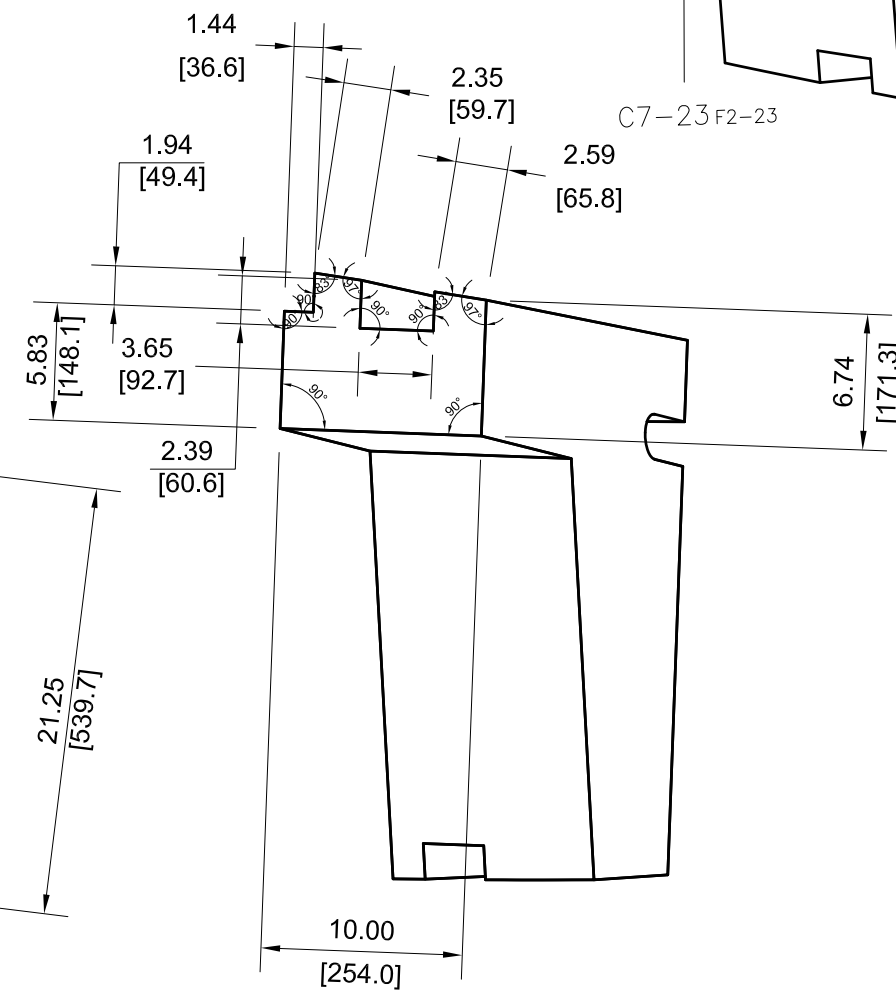

VIEW A8-23

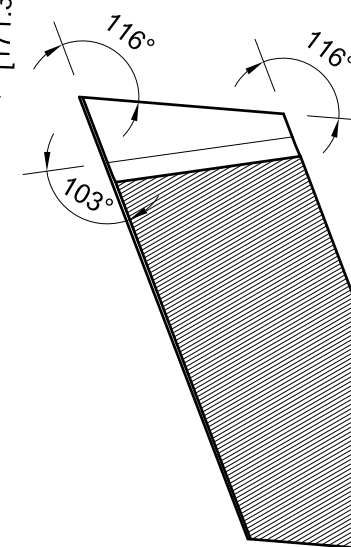

NOTE: ALL VIEWS TAKEN AS TRUE VIEWS PARALLEL TO SURFACE OF PART

		DRAWING NUMBER			
		AES-D0002			
SIZE	SCALE	SHEET	OF	REVISION	
A3	NONE	23	167	F	

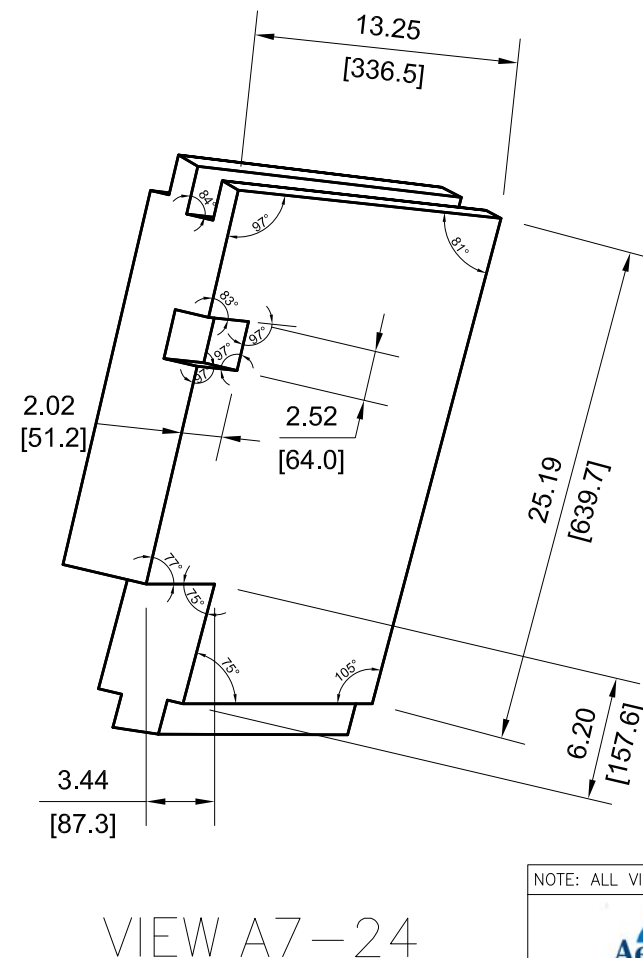
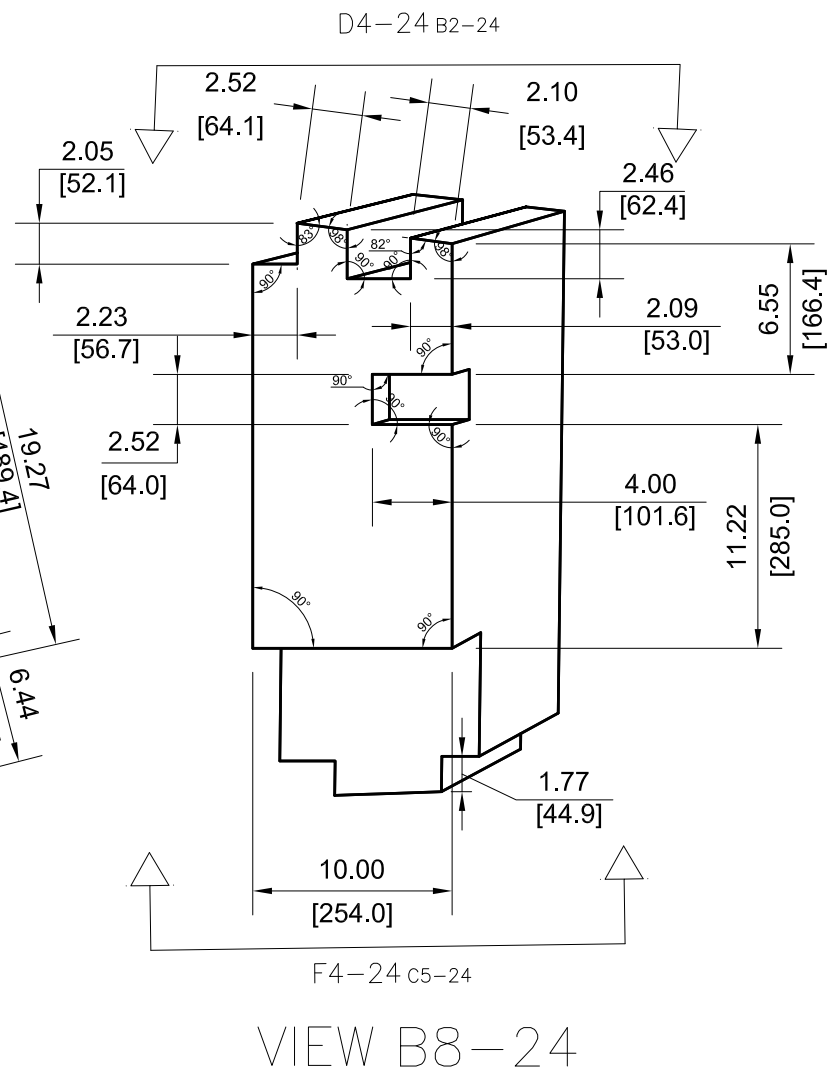
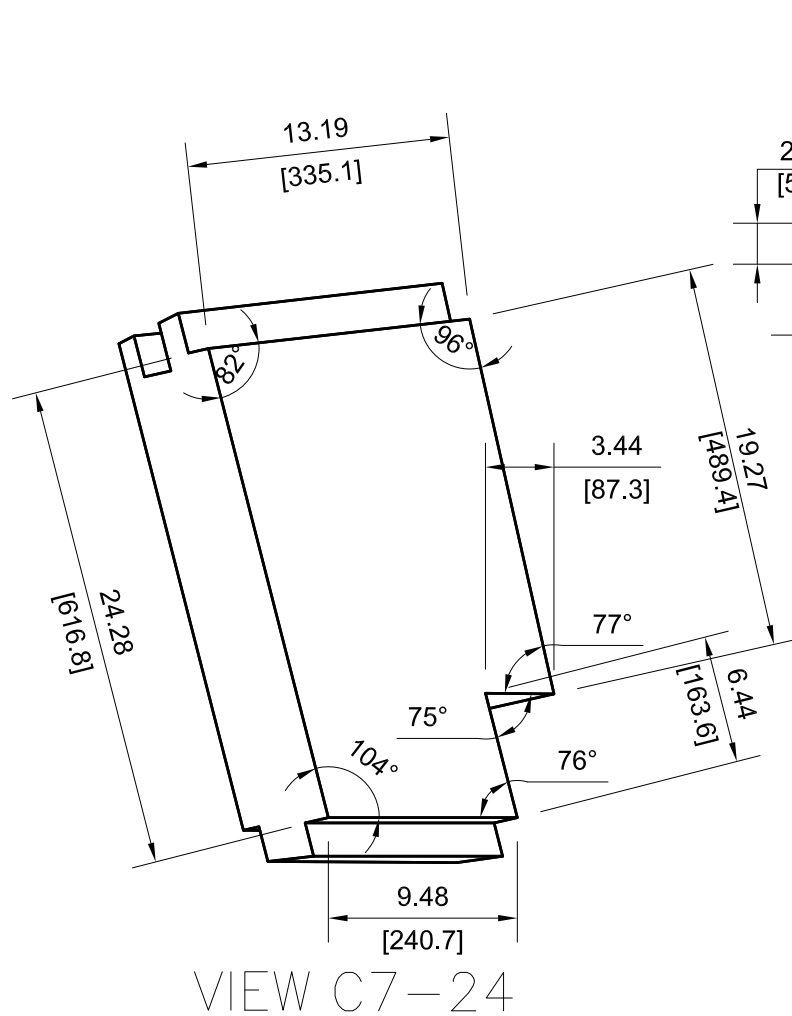
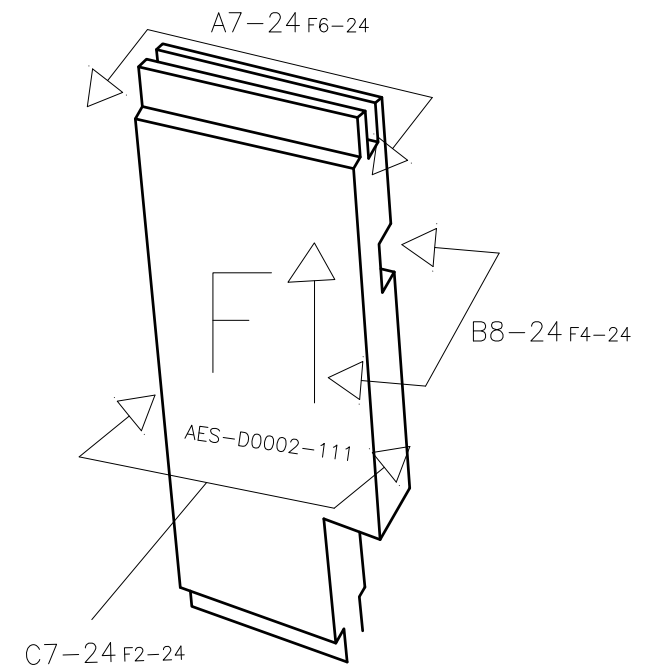
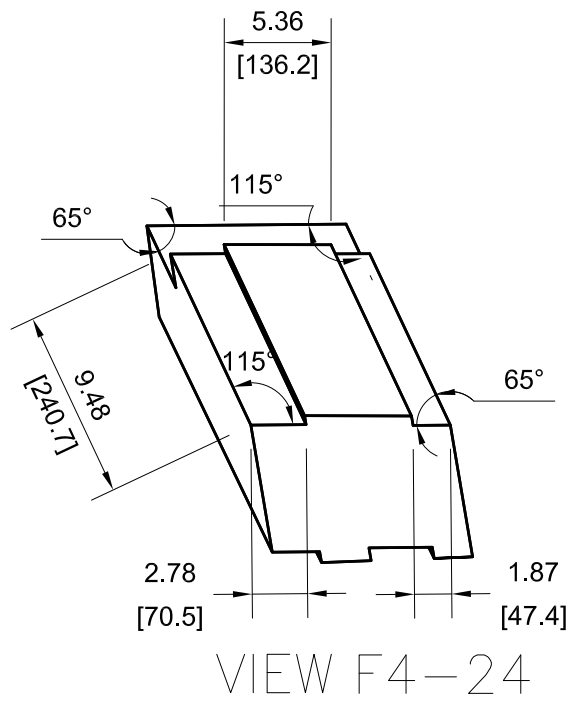
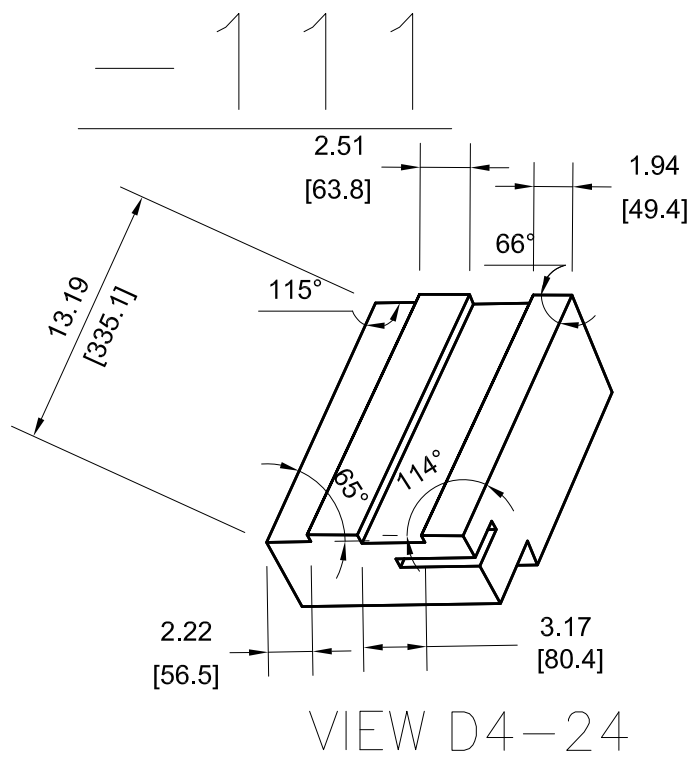

NOTE: ALL VIEWS TAKEN AS TRUE VIEWS PARALLEL TO SURFACE OF PART

		DRAWING NUMBER			
		AES-D0002			
SIZE	SCALE	SHEET	OF	REVISION	
A3	NONE	24	167	F	

-113

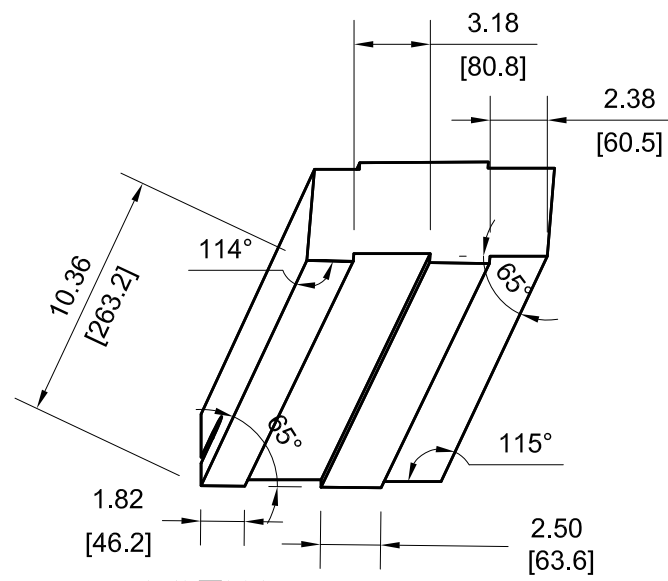

VIEW D4-25

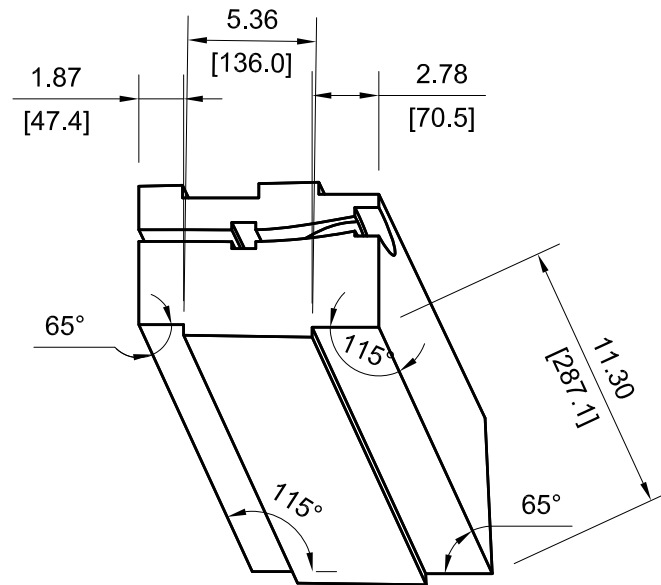

VIEW F4-25

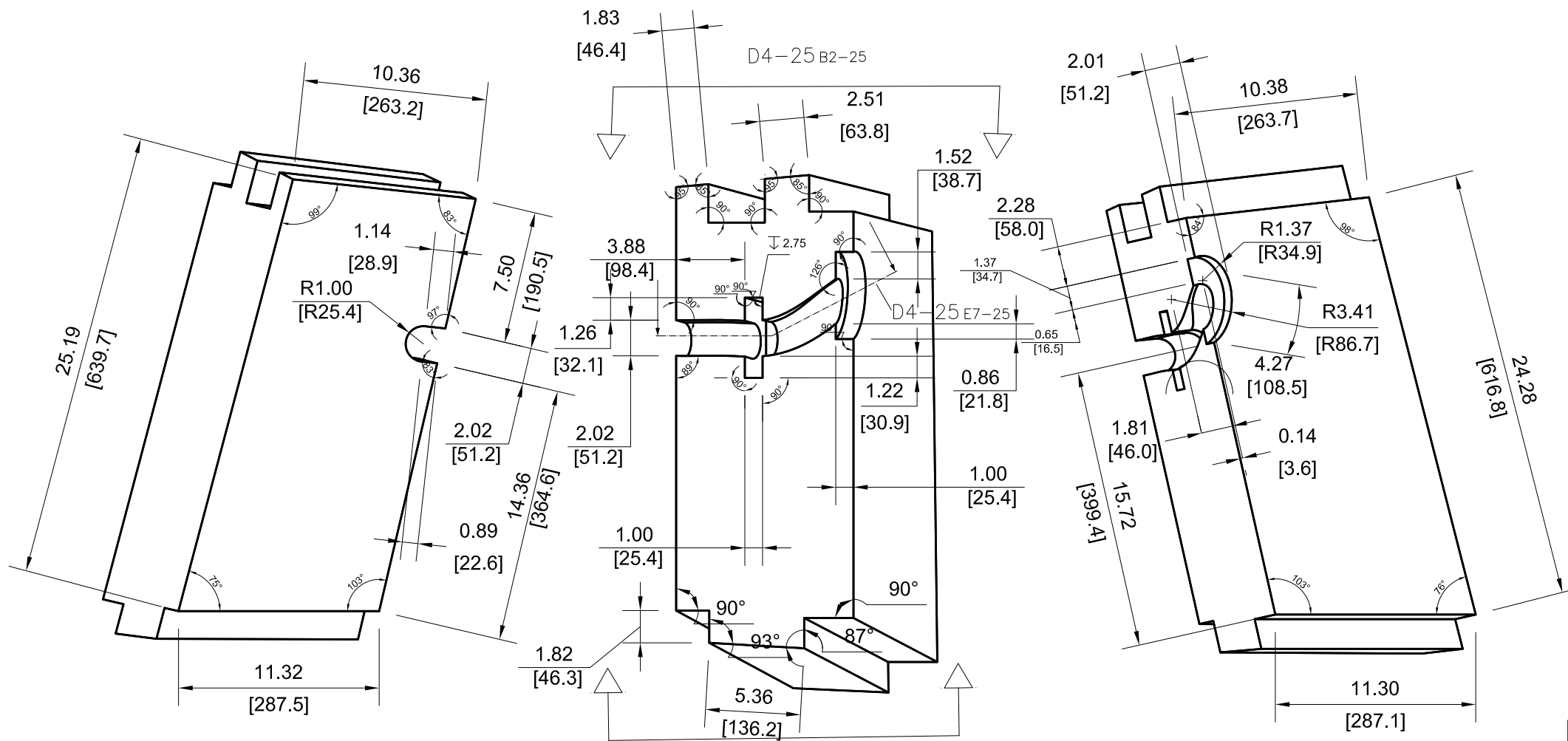
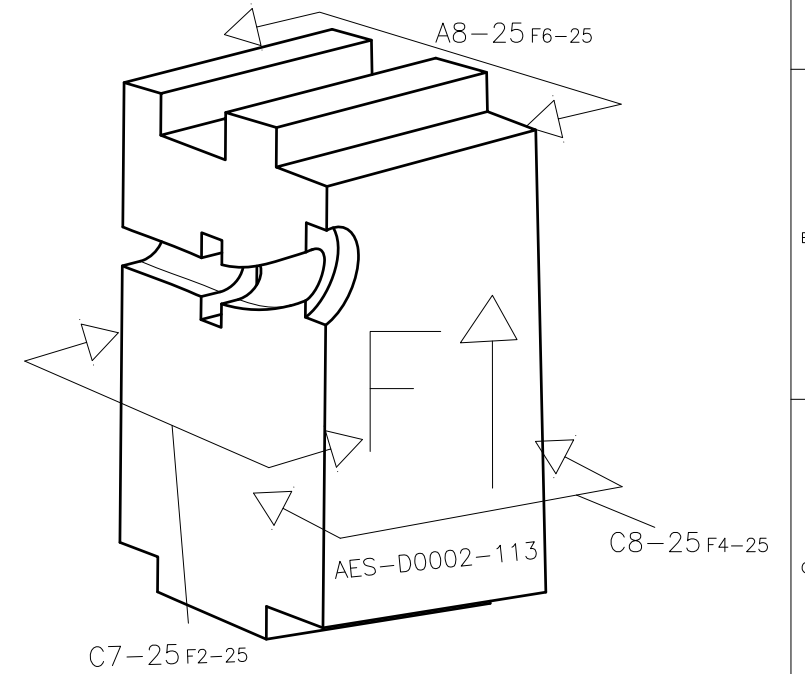

VIEW C7-25

VIEW C8-25

VIEW A8-25

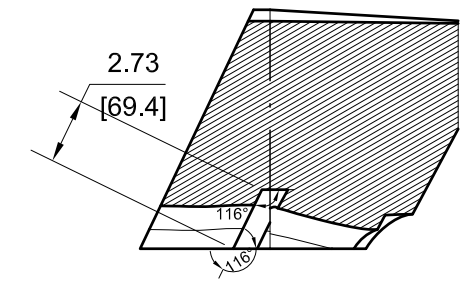

SECTION VIEW D4-25

NOTE: ALL VIEWS TAKEN AS TRUE VIEWS PARALLEL TO SURFACE OF PART

		DRAWING NUMBER			
		AES-D0002			
SIZE	SCALE	SHEET	OF	REVISION	
A3	NONE	25	167	F	

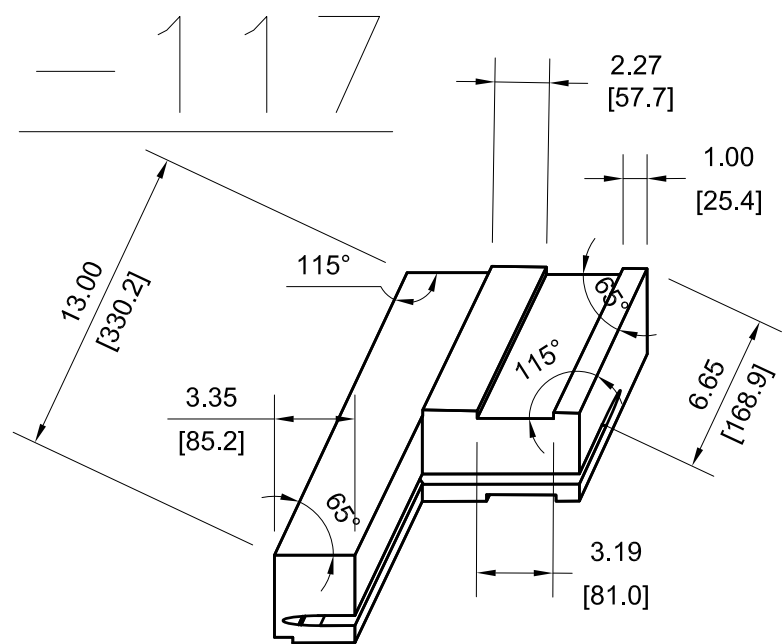

VIEW C4-27

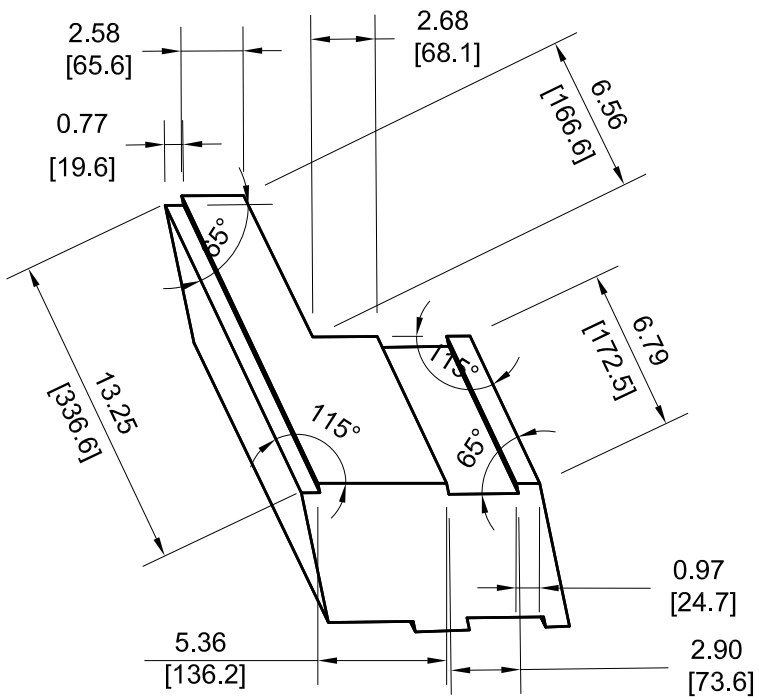

VIEW F4-27

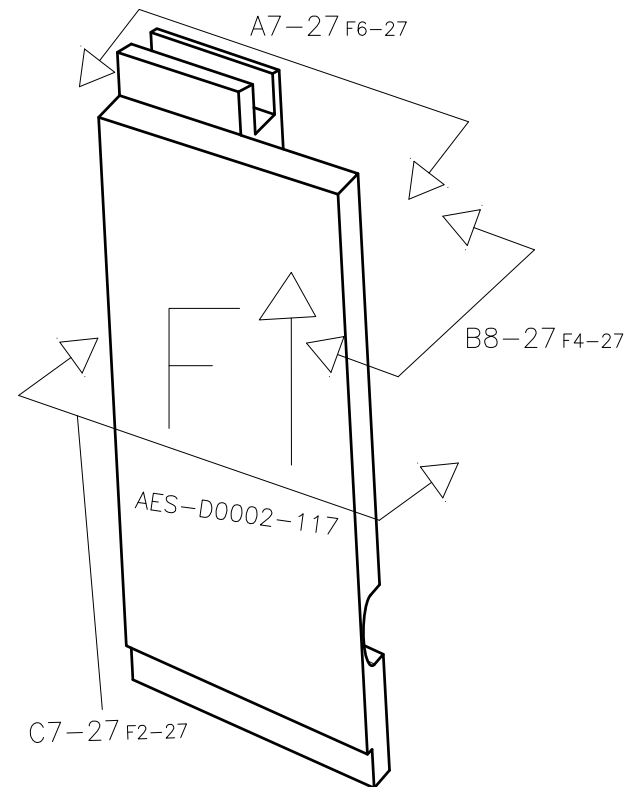

C7-27 F2-27

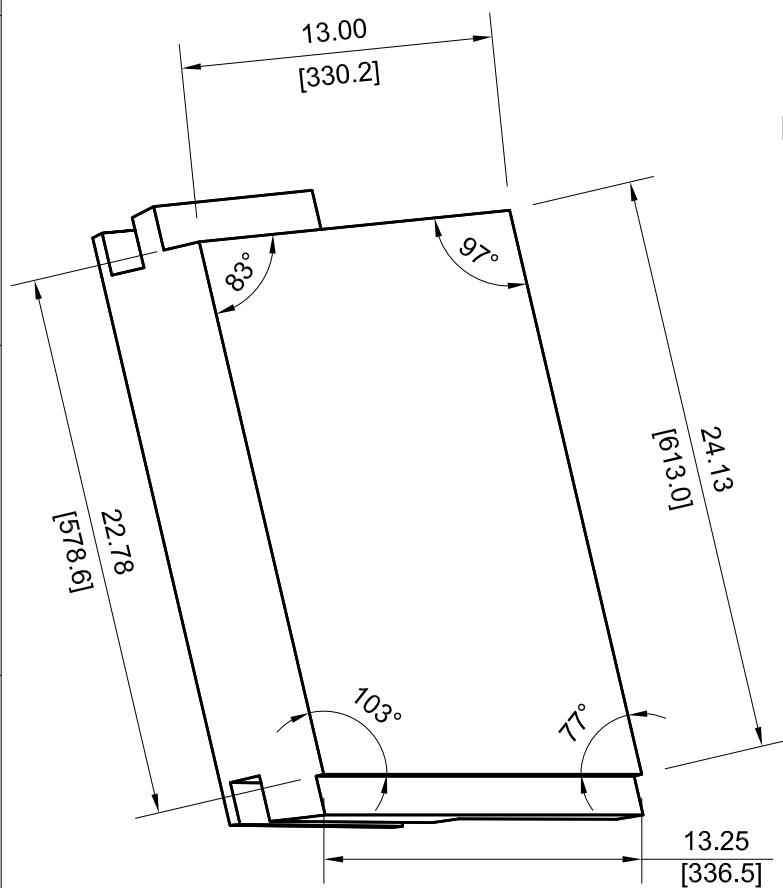

VIEW C7-27

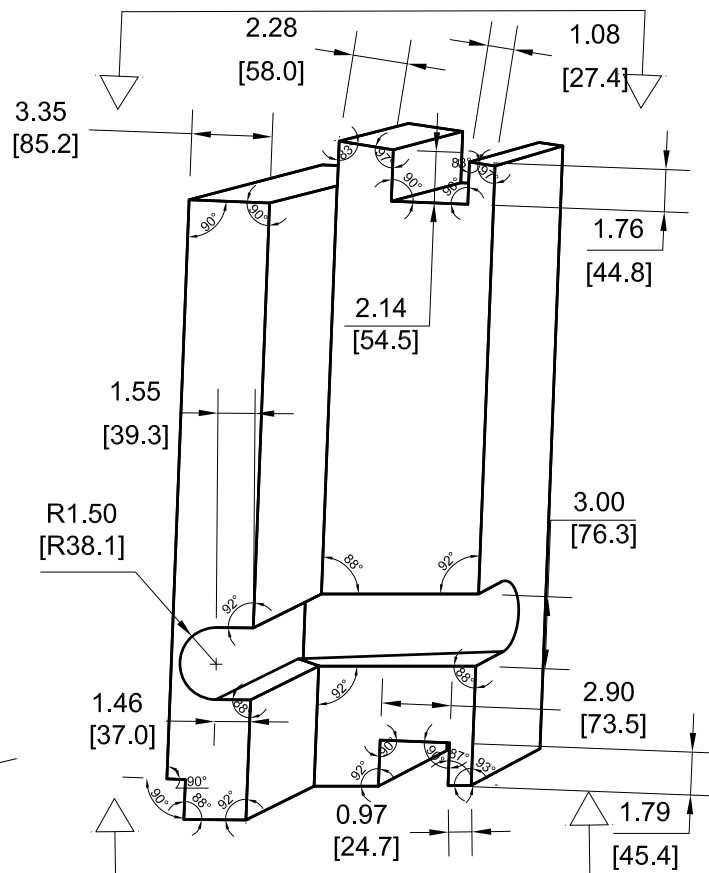

VIEW B8-27

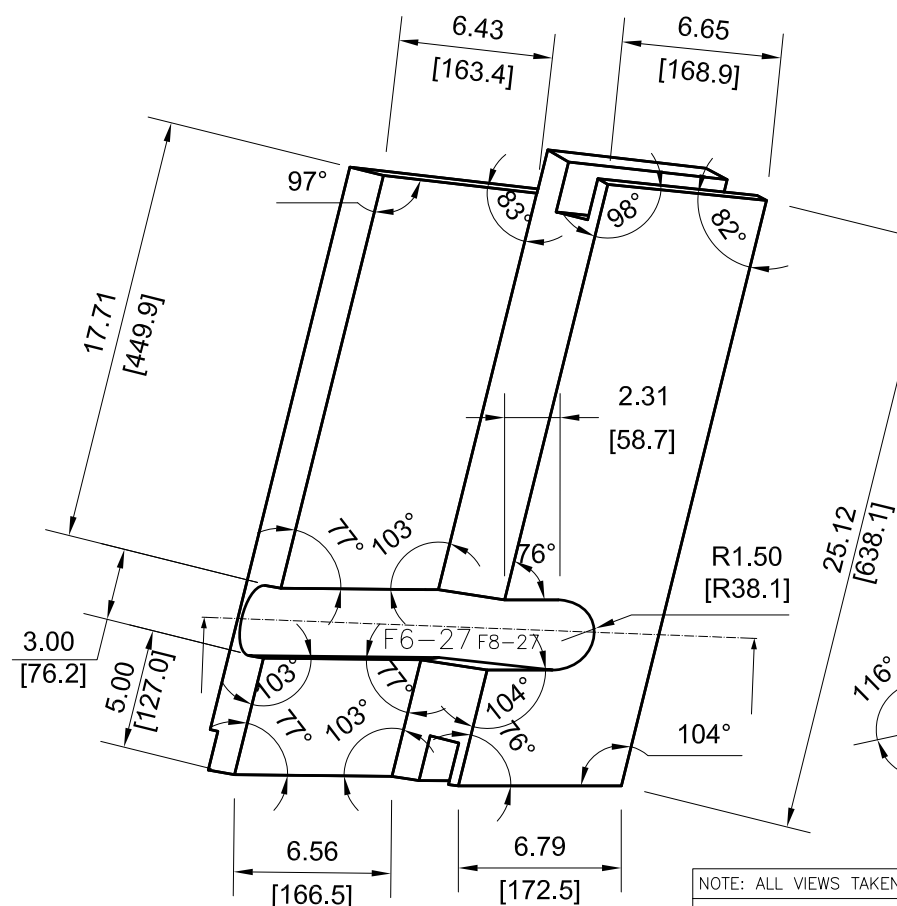

VIEW A7-27

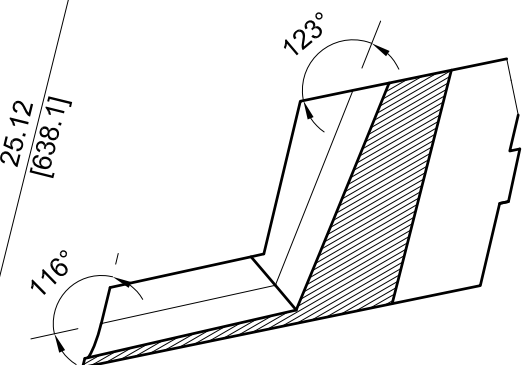

SECTION VIEW F6-27

NOTE: ALL VIEWS TAKEN AS TRUE VIEWS PARALLEL TO SURFACE OF PART

		DRAWING NUMBER			
		AES-D0002			
SIZE	SCALE	SHEET	OF	REVISION	
A3	NONE	27	167	F	

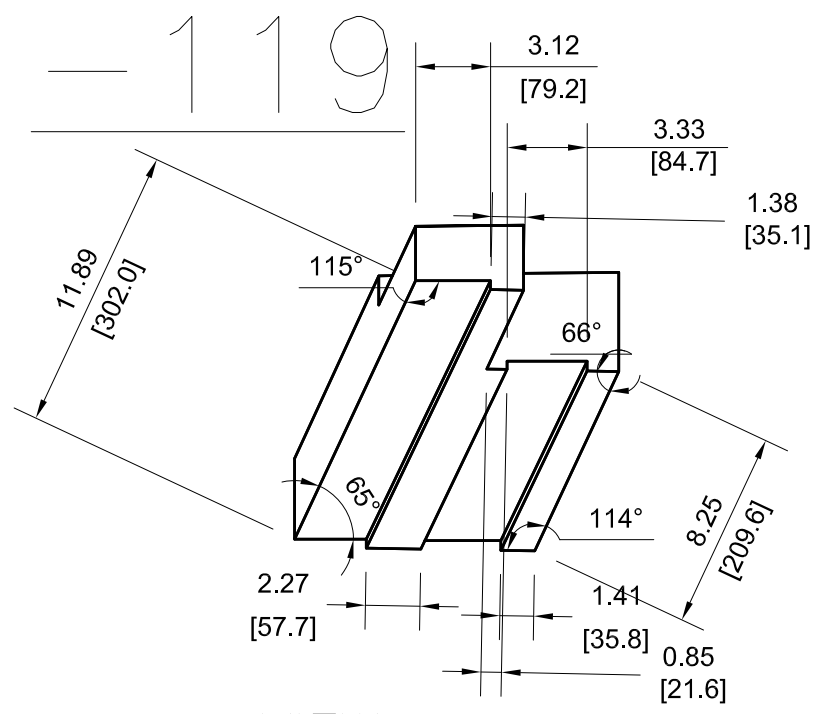

VIEW C4-28

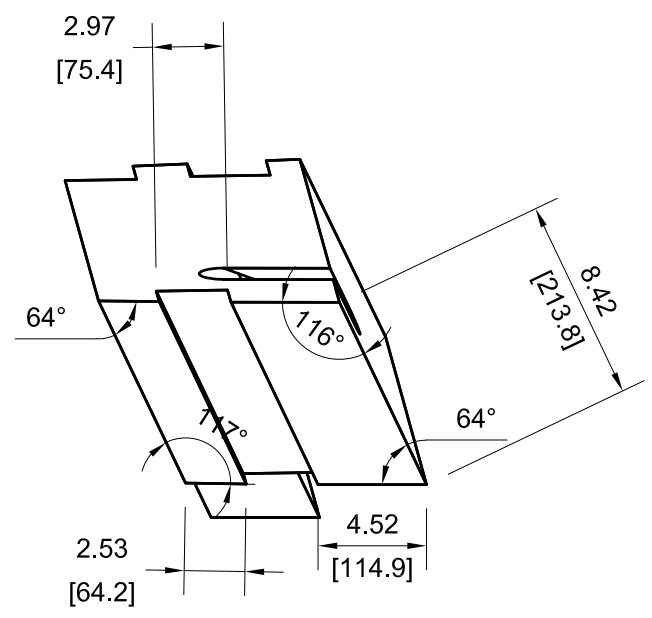

VIEW F4-28

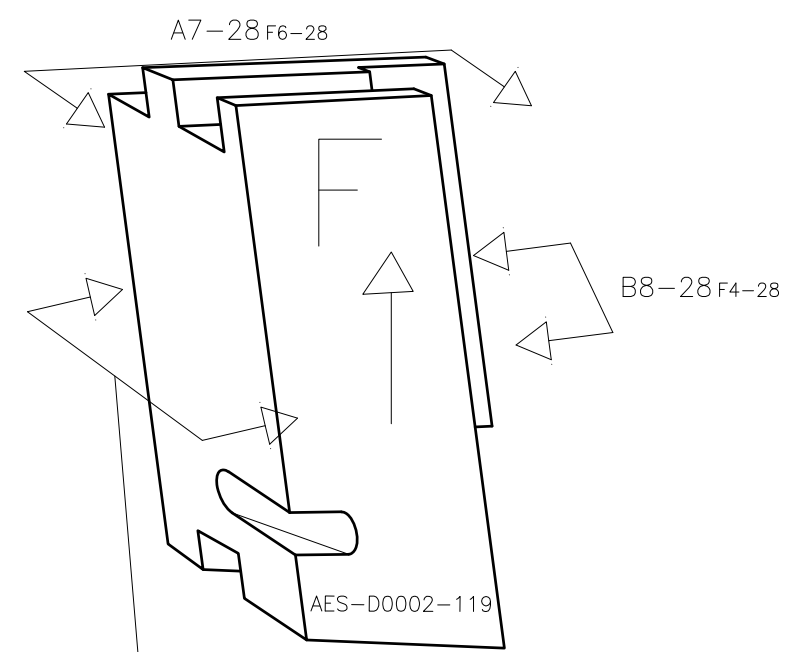

C7-28 F2-28

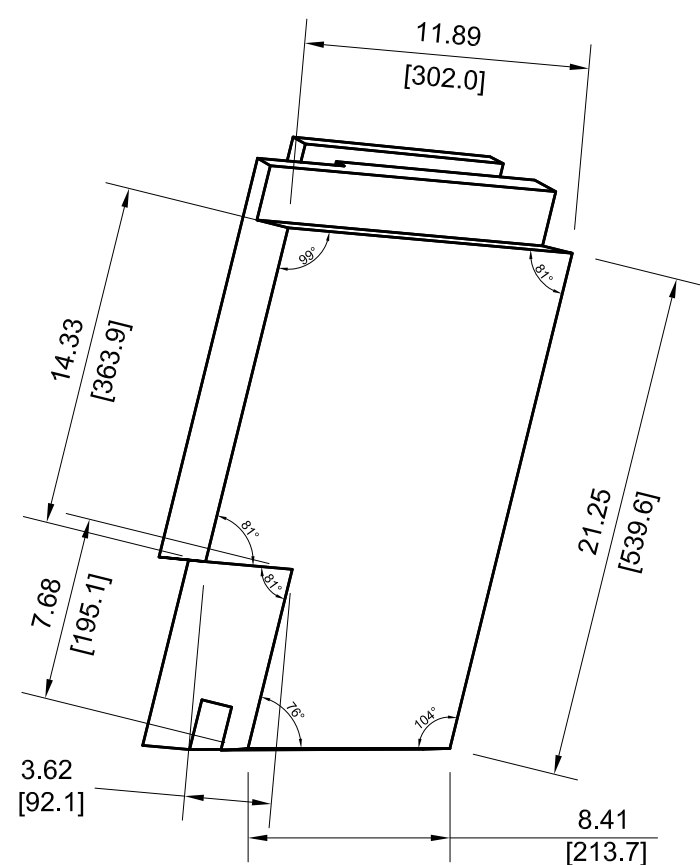

VIEW C7-28

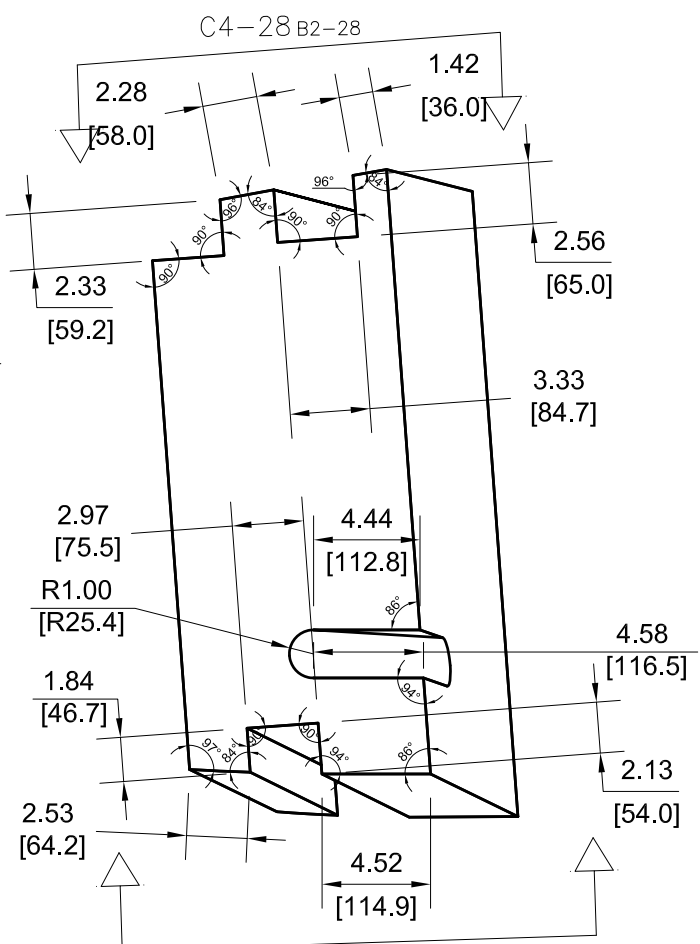

VIEW B8-28

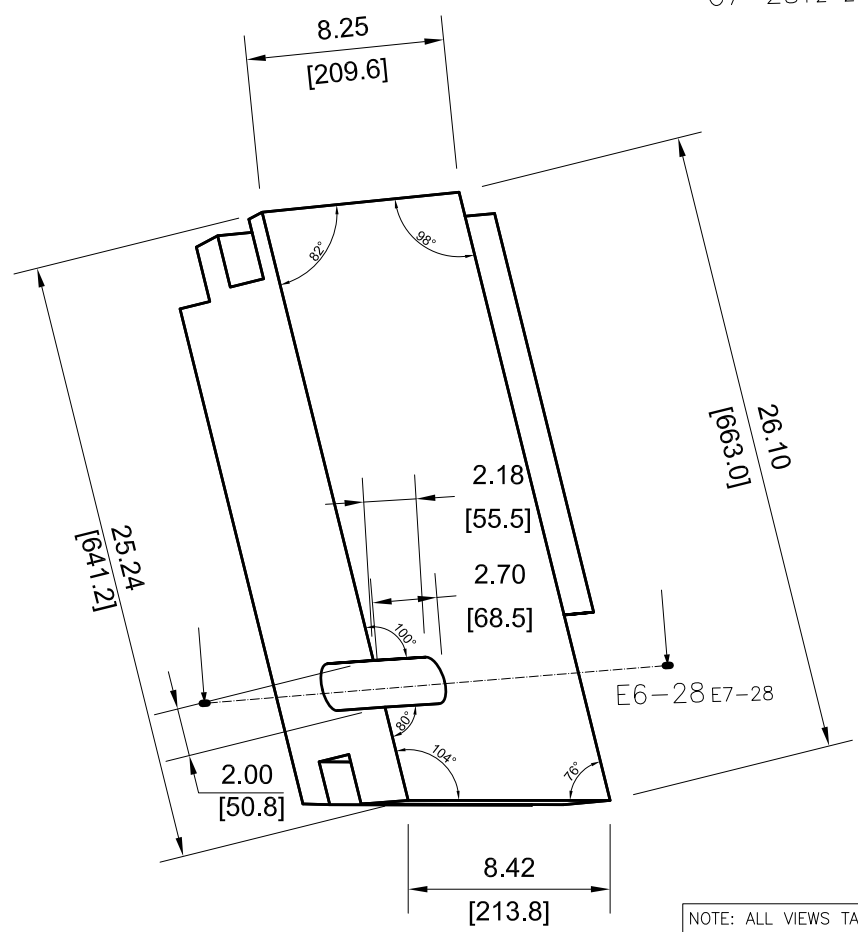

VIEW A7-28

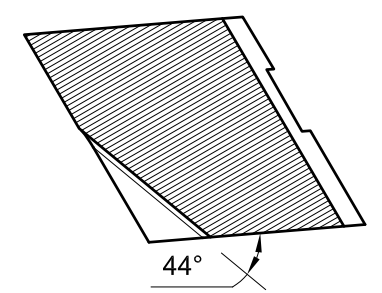

SECTION VIEW E6-28

NOTE: ALL VIEWS TAKEN AS TRUE VIEWS PARALLEL TO SURFACE OF PART

		DRAWING NUMBER			
		AES-D0002			
SIZE	SCALE	SHEET	OF	REVISION	
A3	NONE	28	167	F	

-121

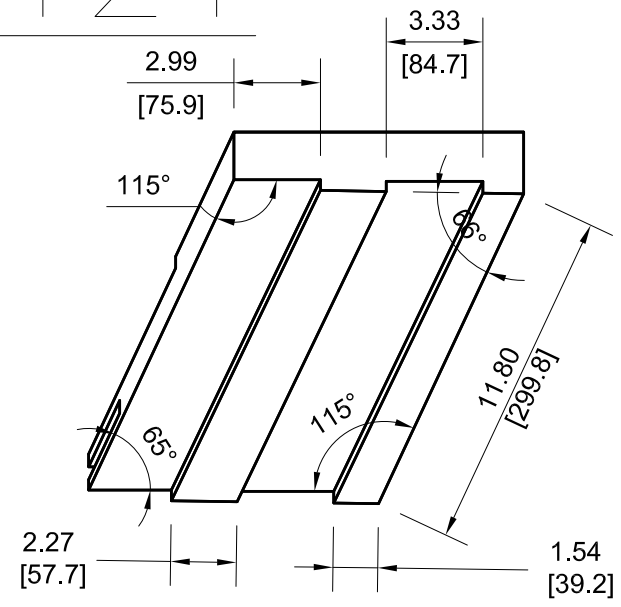

VIEW C4-29

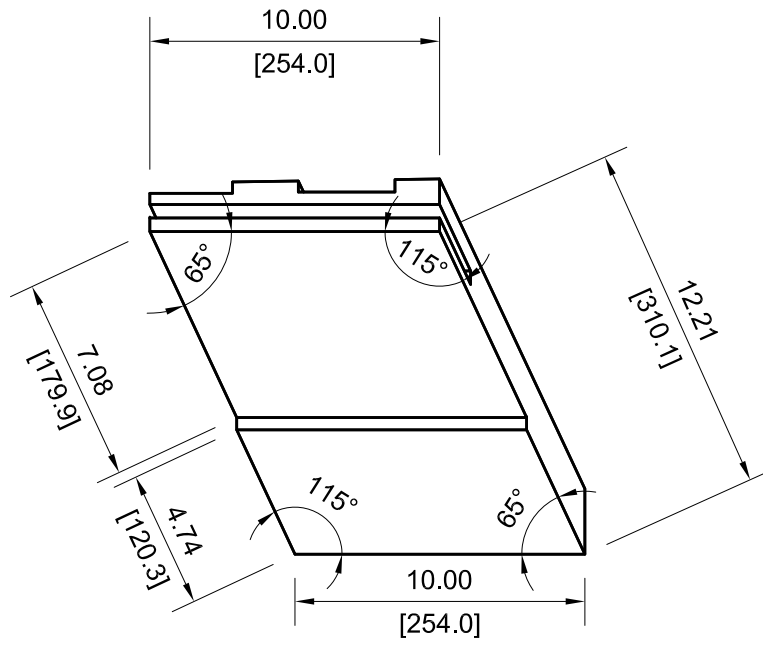

VIEW F4-29

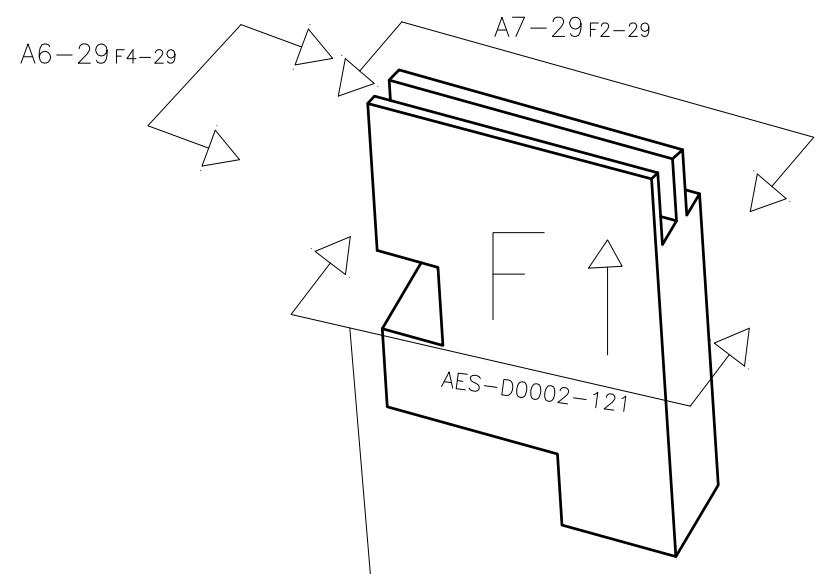

C7-29 F6-29

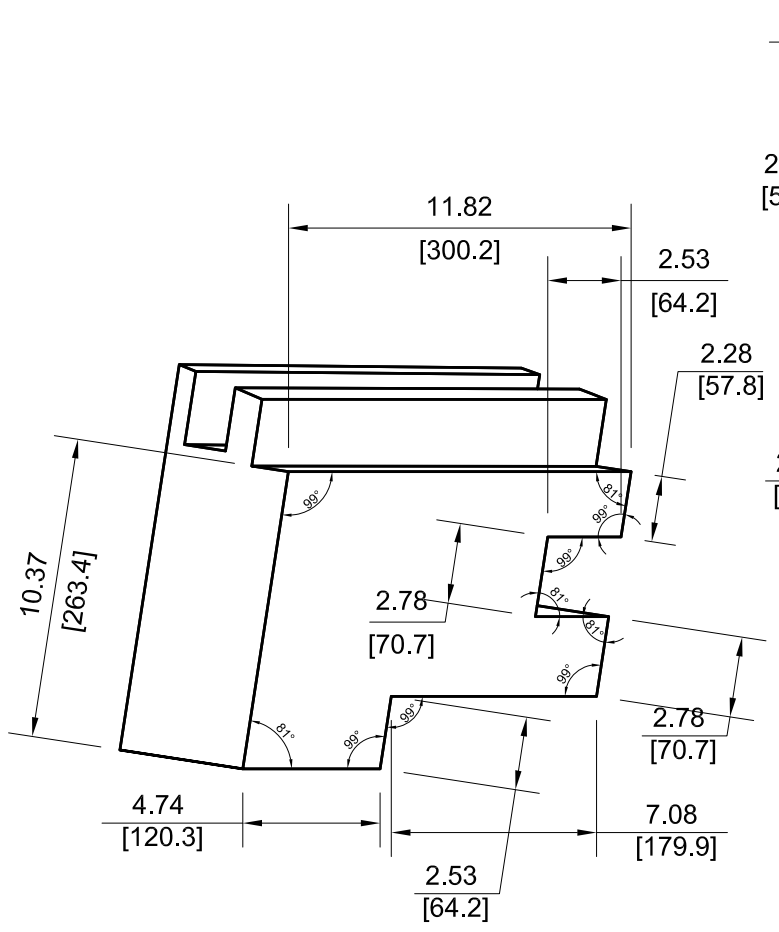

VIEW A7-29

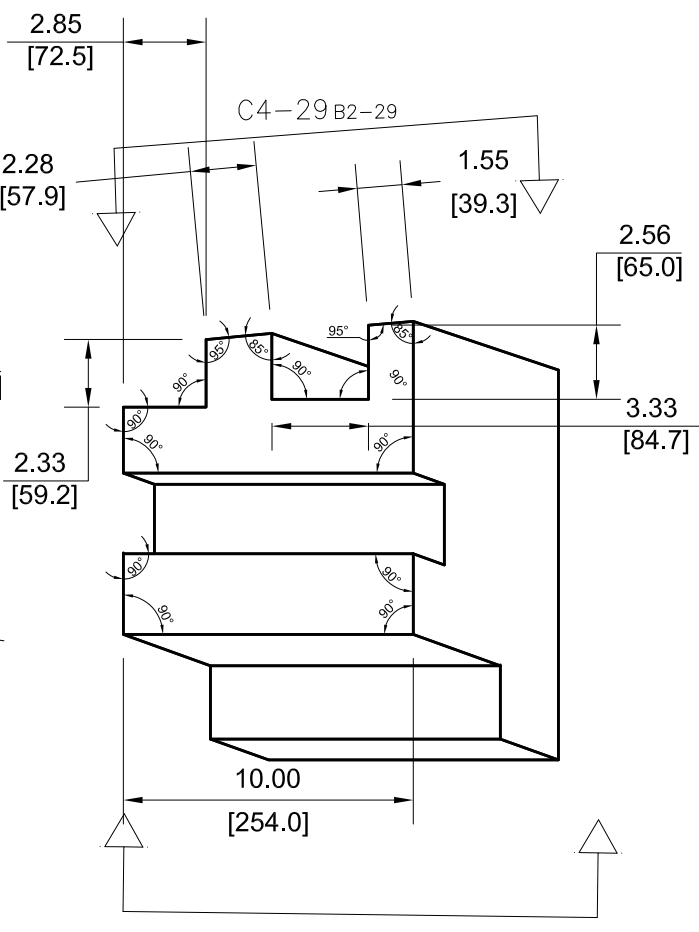

VIEW A6-29

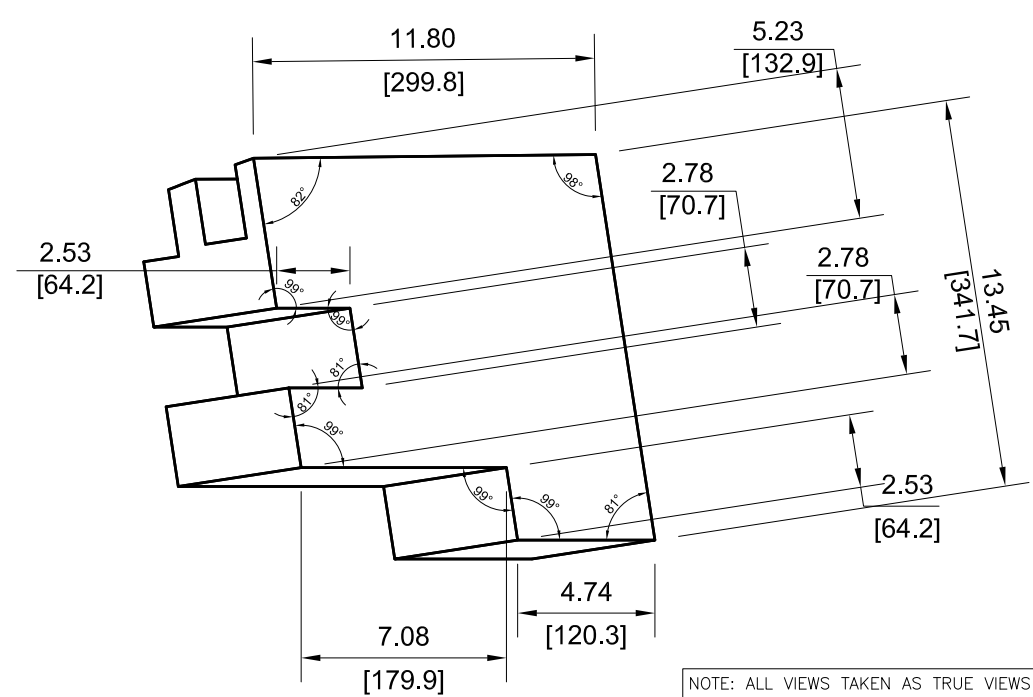

VIEW C7-29

NOTE: ALL VIEWS TAKEN AS TRUE VIEWS PARALLEL TO SURFACE OF PART

		DRAWING NUMBER			
		AES-D0002			
SIZE	SCALE	SHEET	OF	REVISION	
A3	NONE	29	167	F	

-123

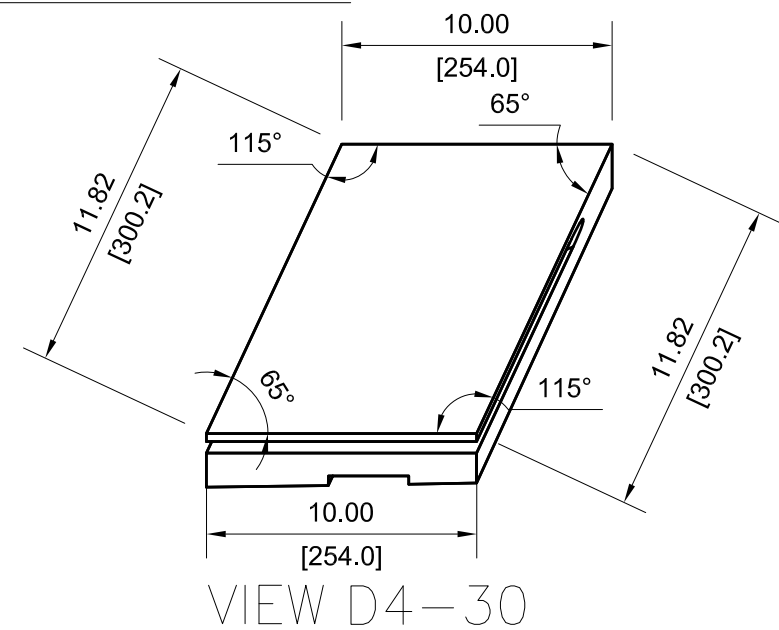

VIEW D4-30

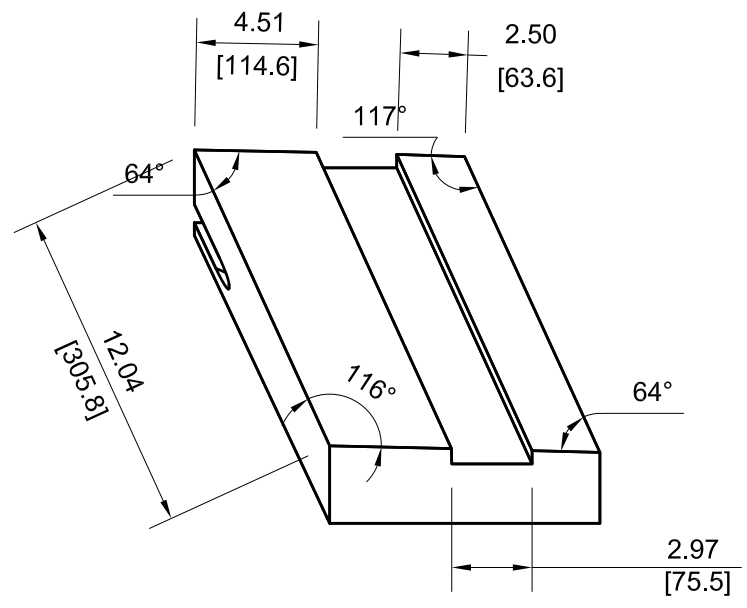

VIEW F4-30

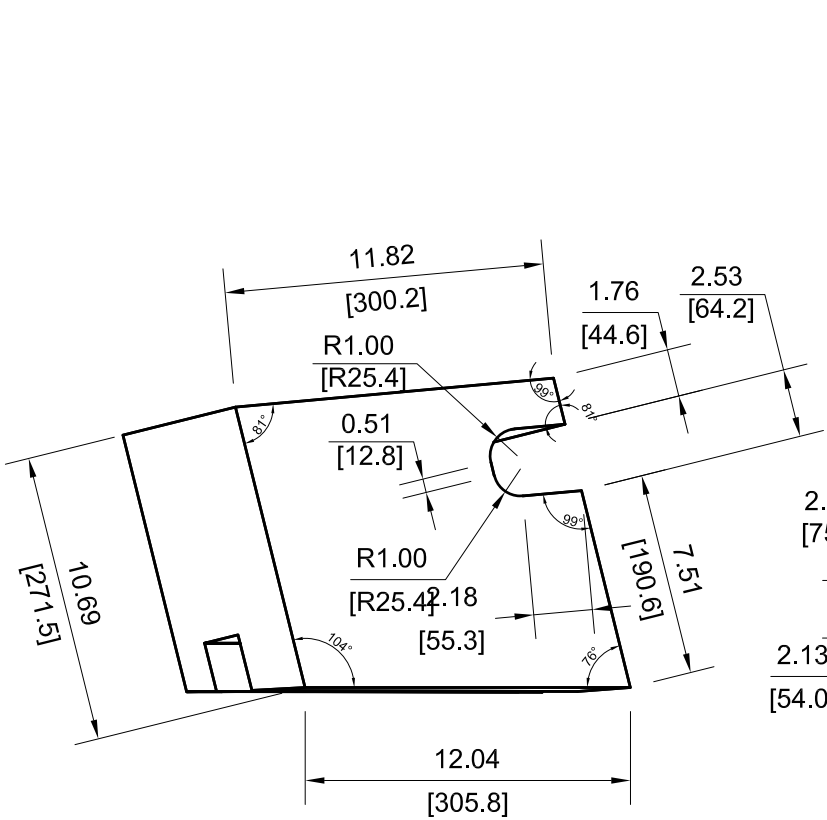
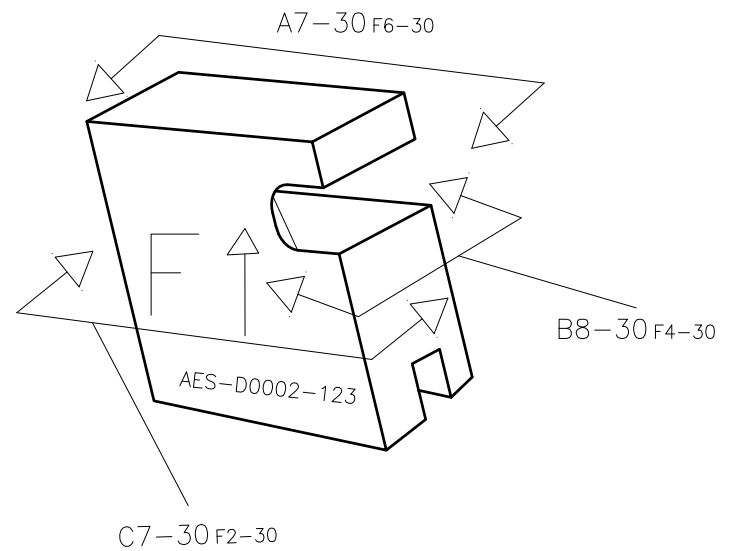

VIEW C7-30

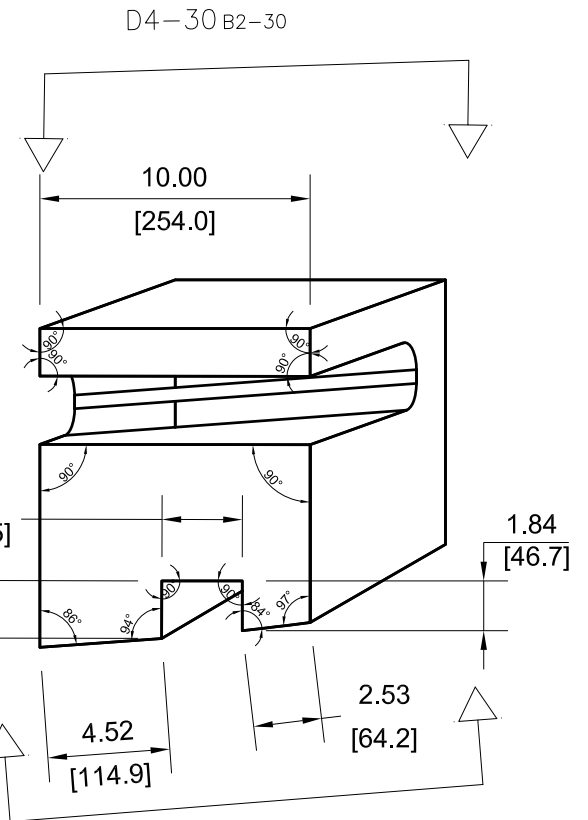

VIEW B8-30

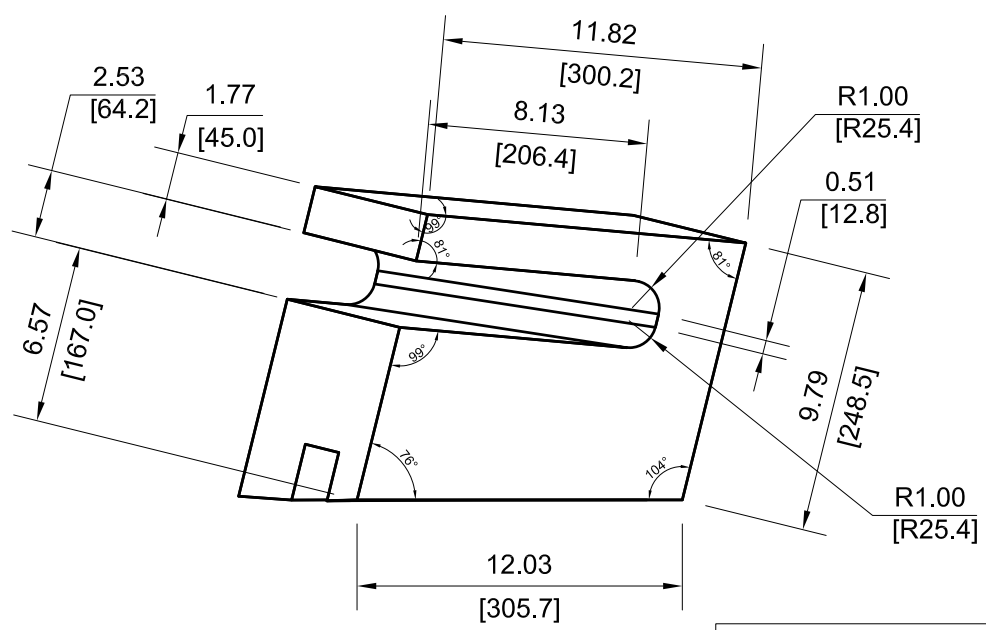

VIEW A7-30

NOTE: ALL VIEWS TAKEN AS TRUE VIEWS PARALLEL TO SURFACE OF PART

		DRAWING NUMBER			
		AES-D0002			
SIZE	SCALE	SHEET	OF	REVISION	
A3	NONE	30	167	F	

-125

A3-31E2-31

VIEW C4-31

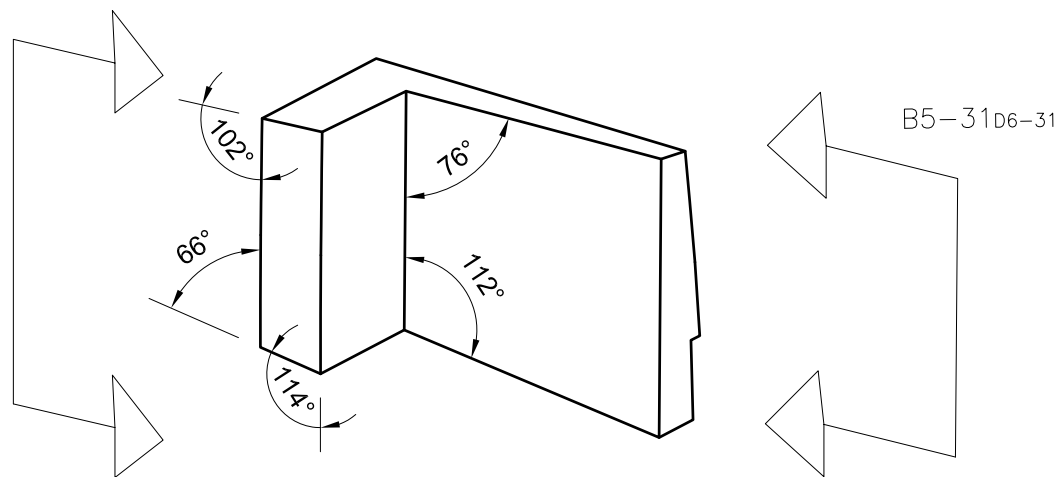

B5-31D6-31

VIEW B5-31

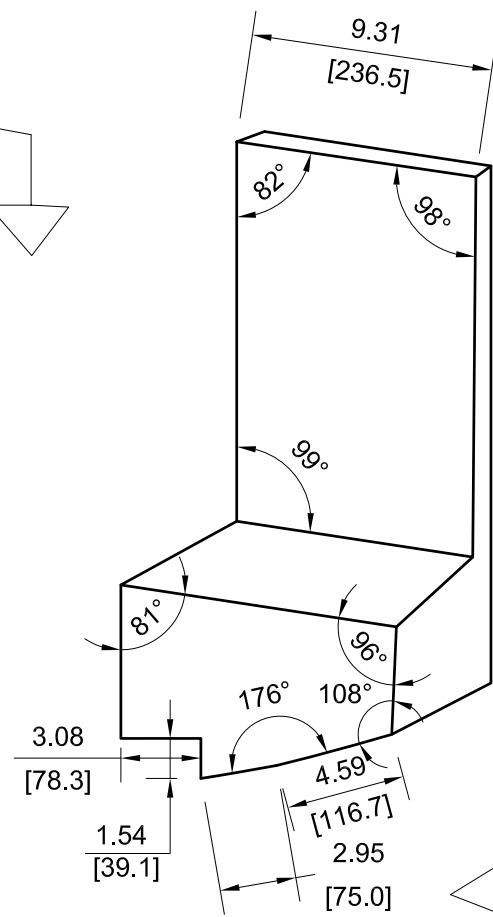

C4-31B4-31

VIEW F7-31

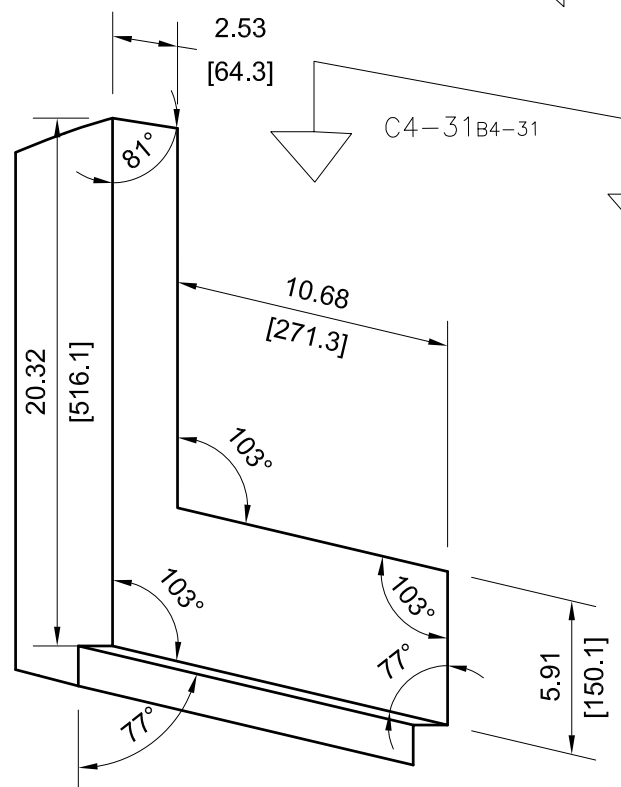

F7-31E4-31

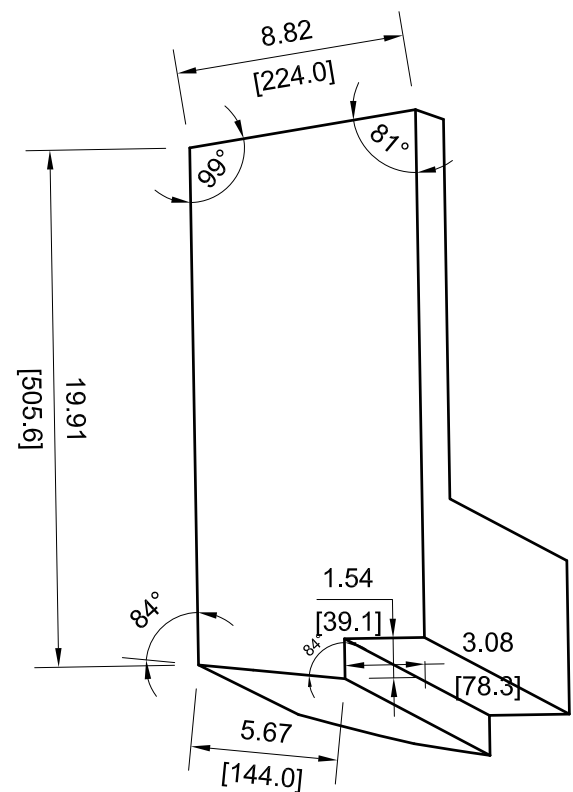
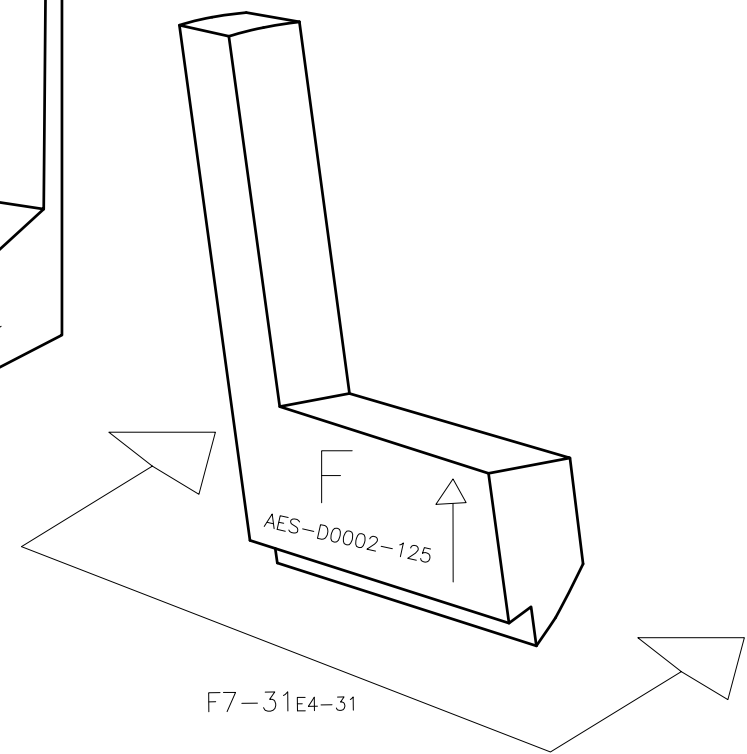

VIEW A3-31

NOTE: ALL VIEWS TAKEN AS TRUE VIEWS PARALLEL TO SURFACE OF PART



DRAWING NUMBER					AES-D0002	
SIZE	SCALE	SHEET	OF	REVISION		
A3	NONE	31	167	F		

-127

VIEW C5-32

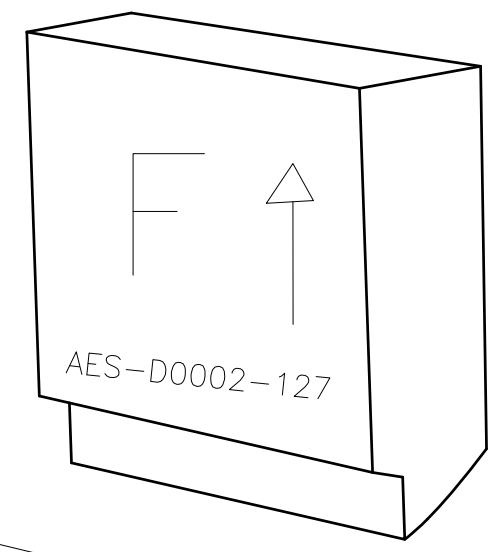
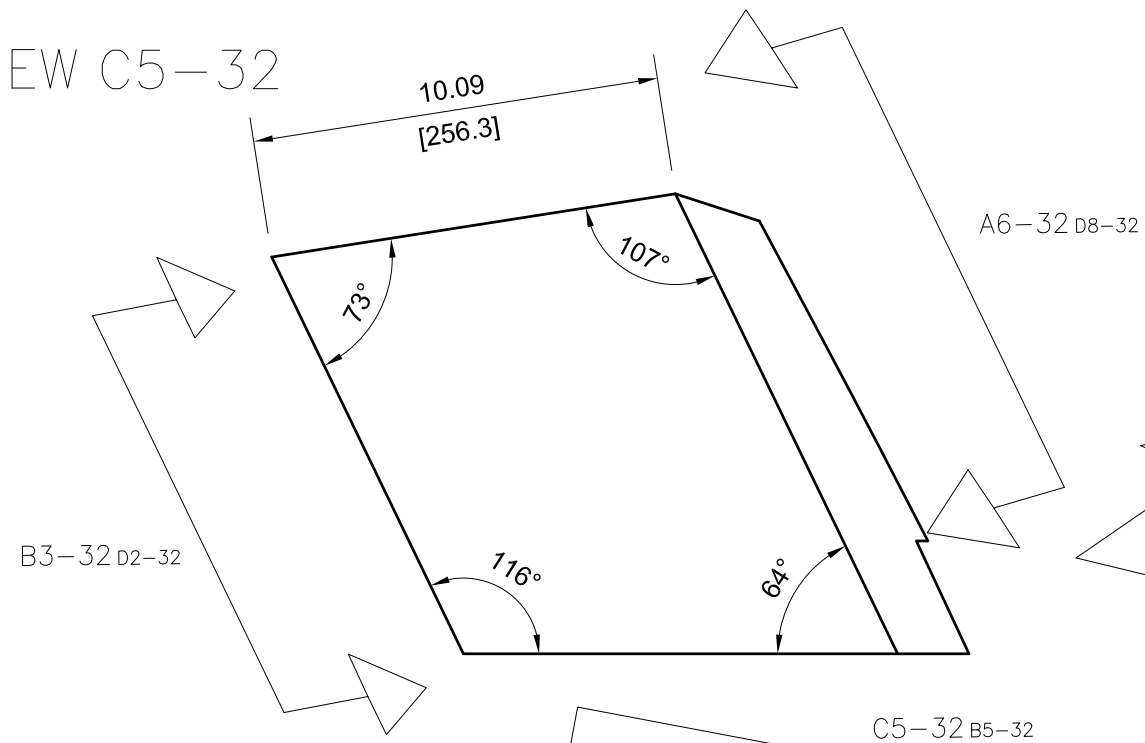

C7-32 D4-32

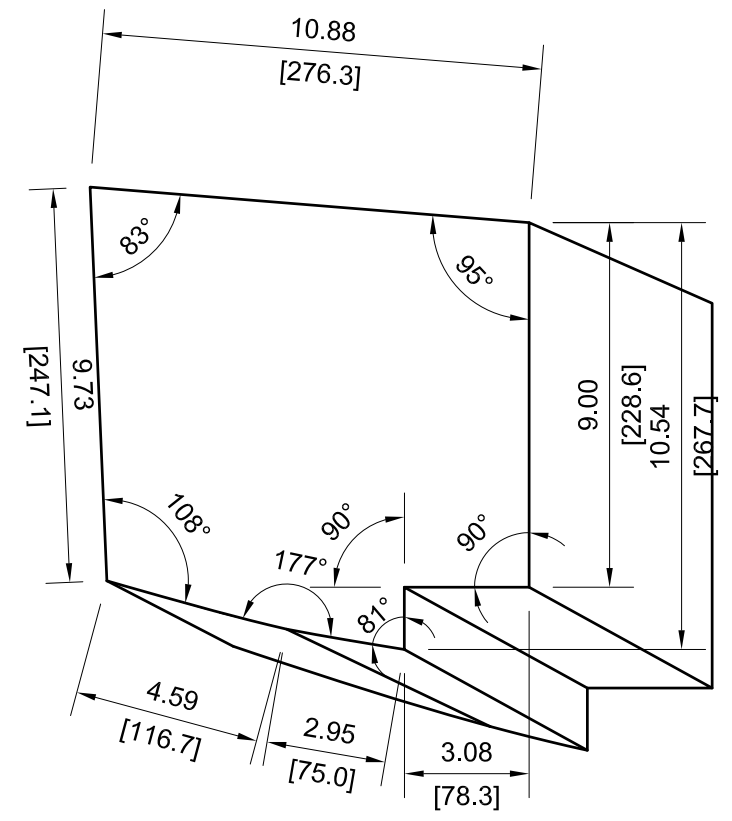

VIEW B3-32

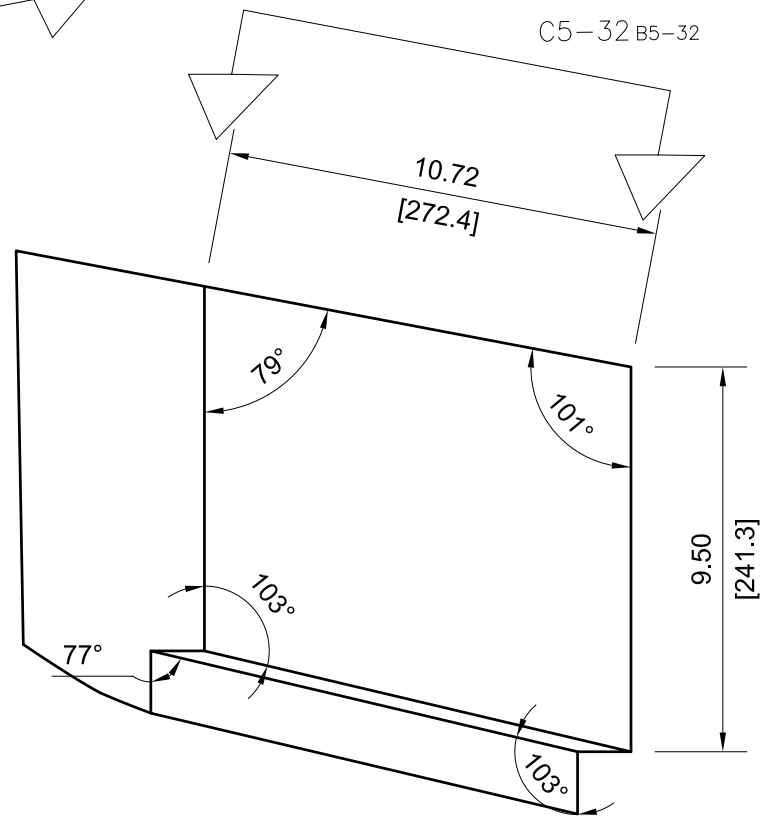

VIEW C7-32

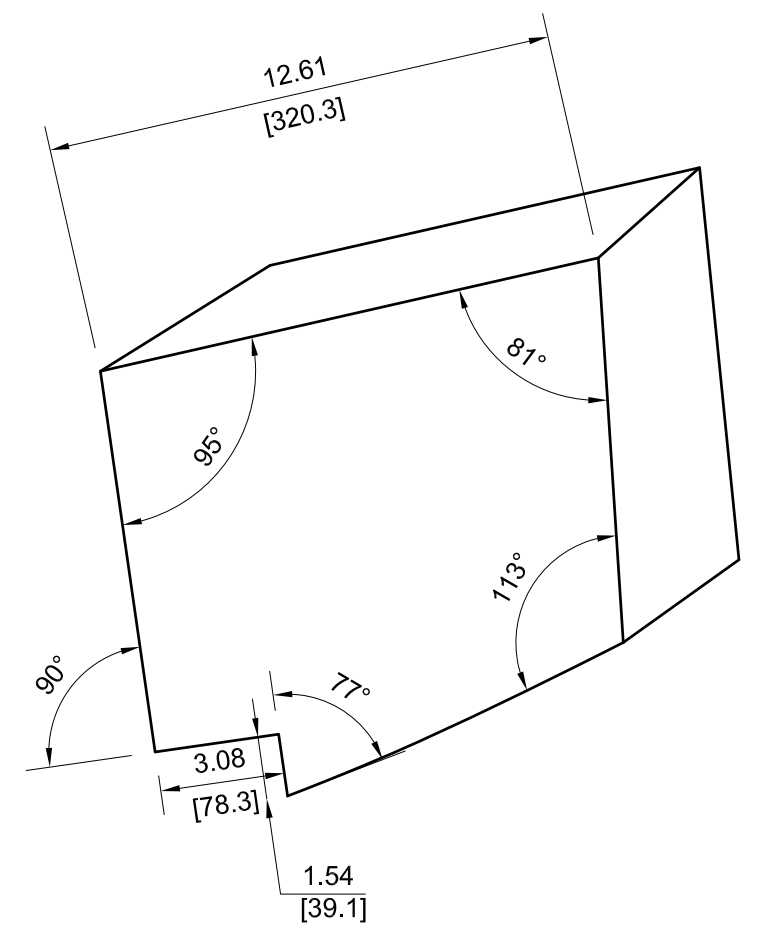

VIEW A6-32

NOTE: ALL VIEWS TAKEN AS TRUE VIEWS PARALLEL TO SURFACE OF PART

	DRAWING NUMBER				
	AES-D0002				
SIZE	SCALE	SHEET	OF	REVISION	
A3	NONE	32	167	F	

-129

VIEW D6-33

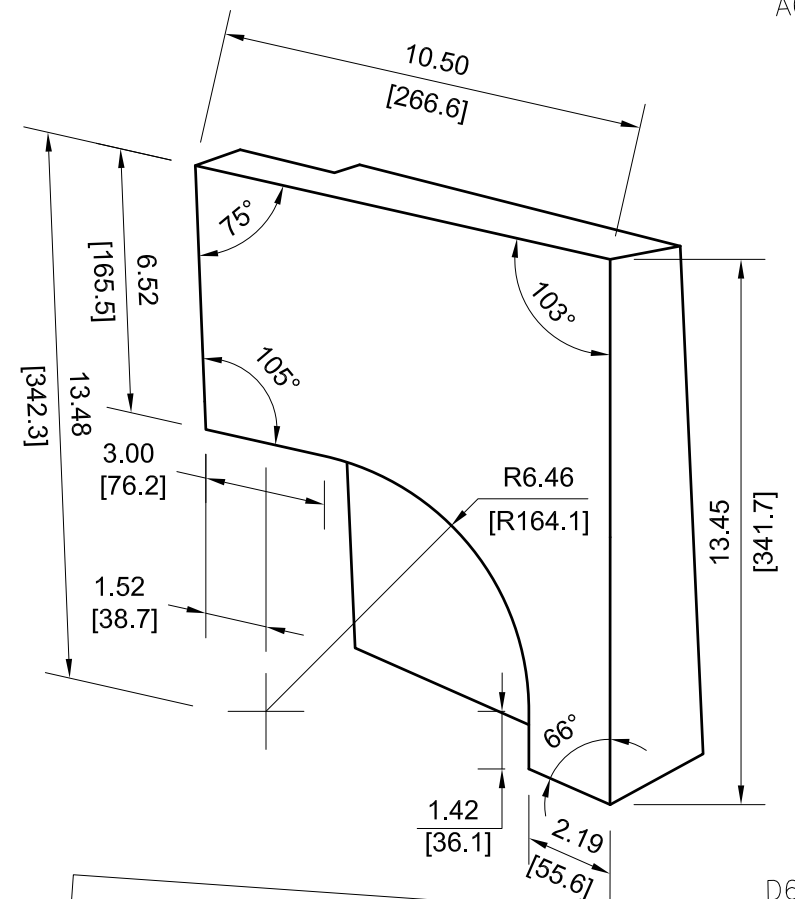

A6-33 D2-33

B6-33 D7-33

C7-33 D4-33

D6-33 B4-33

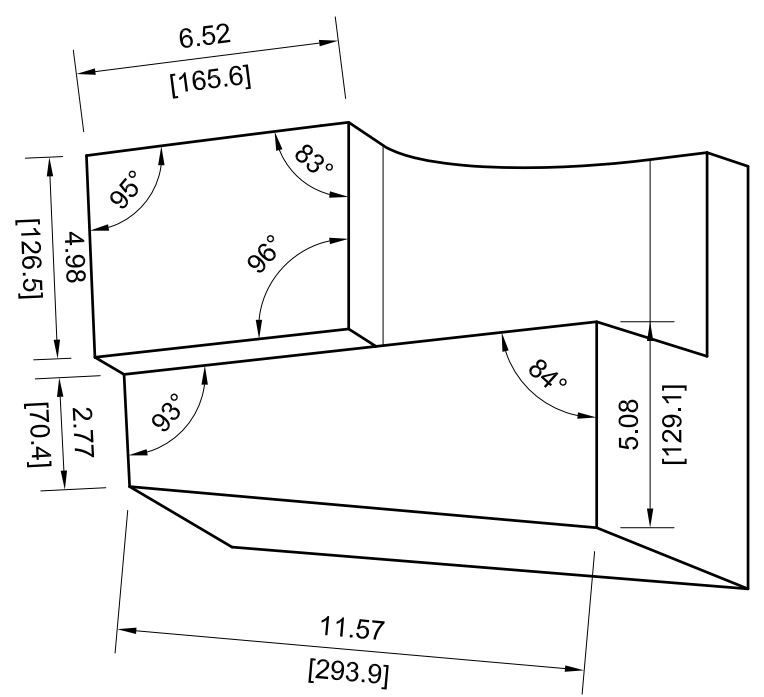

VIEW A6-33

VIEW C7-33

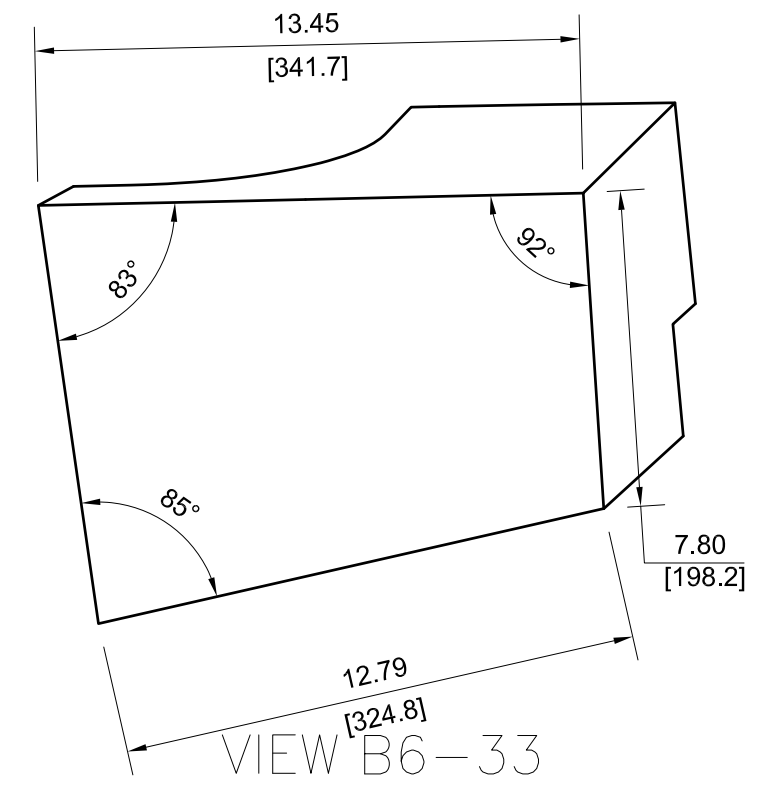

VIEW B6-33

NOTE: ALL VIEWS TAKEN AS TRUE VIEWS PARALLEL TO SURFACE OF PART

		DRAWING NUMBER			
		AES-D0002			
SIZE	SCALE	SHEET	OF	REVISION	
A3	NONE	33	167	F	

-131

VIEW C4-34

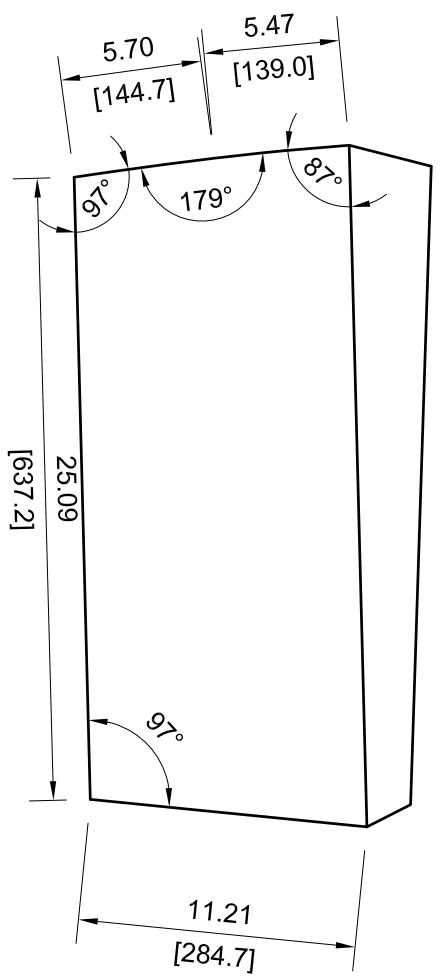
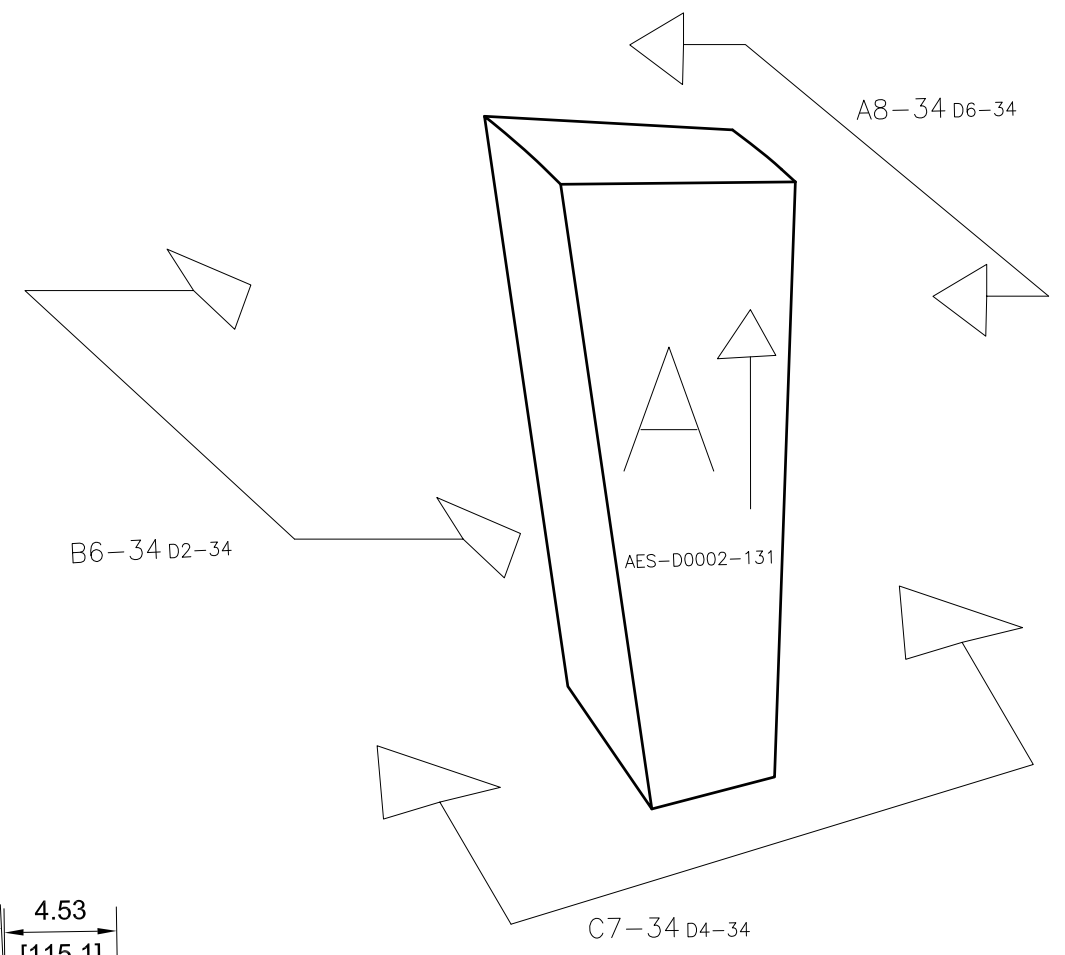
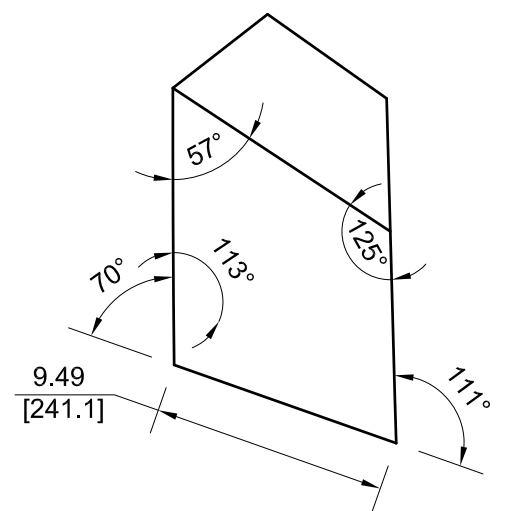

VIEW B6-34

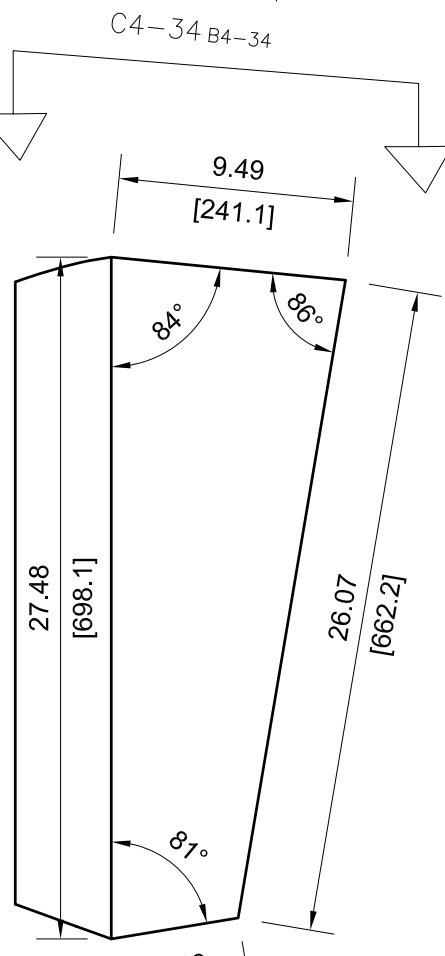
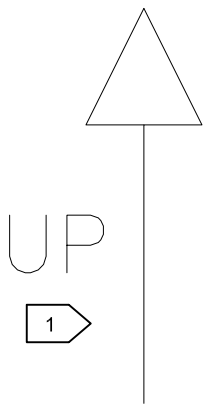

VIEW C7-34

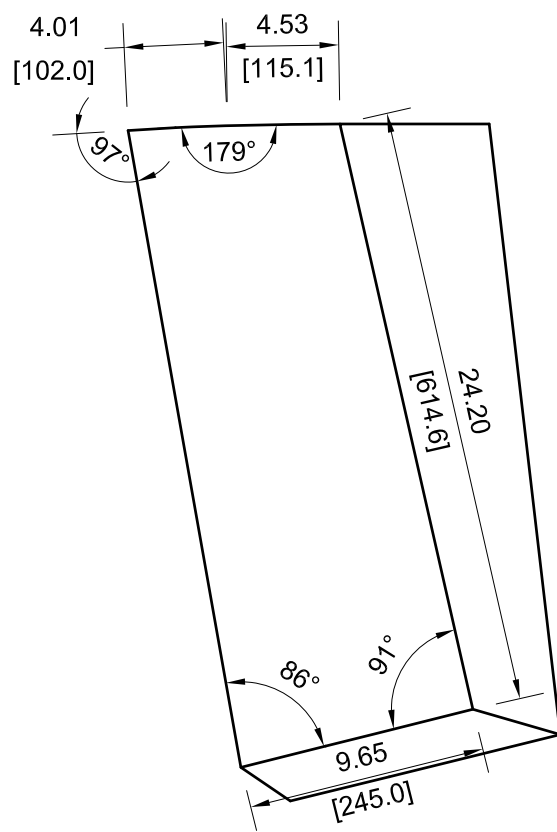

VIEW A8-34

NOTE: ALL VIEWS TAKEN AS TRUE VIEWS PARALLEL TO SURFACE OF PART

		DRAWING NUMBER			
		AES-D0002			
SIZE	SCALE	SHEET	OF	REVISION	
A3	NONE	34	167	F	

-133

VIEW C4-35

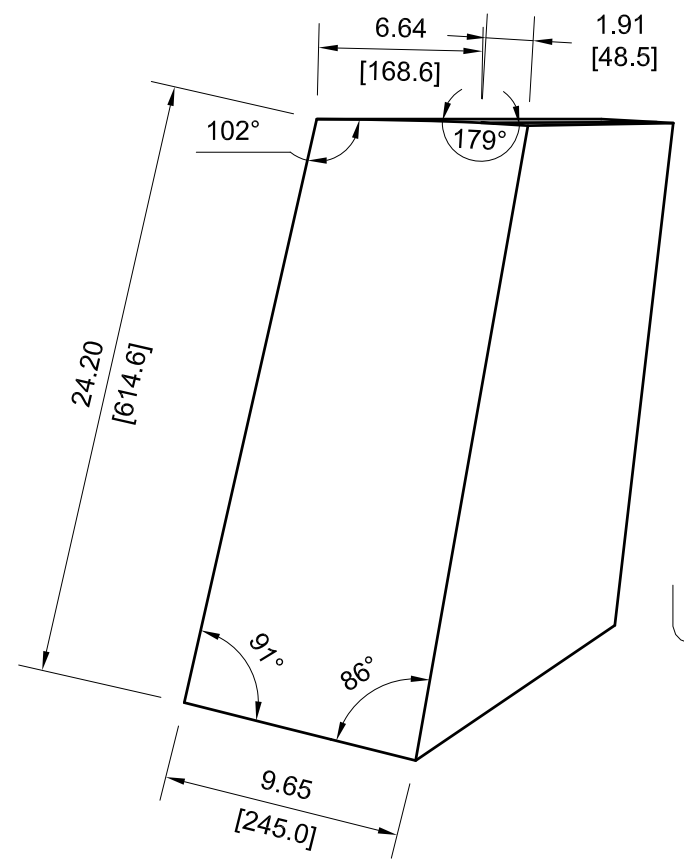
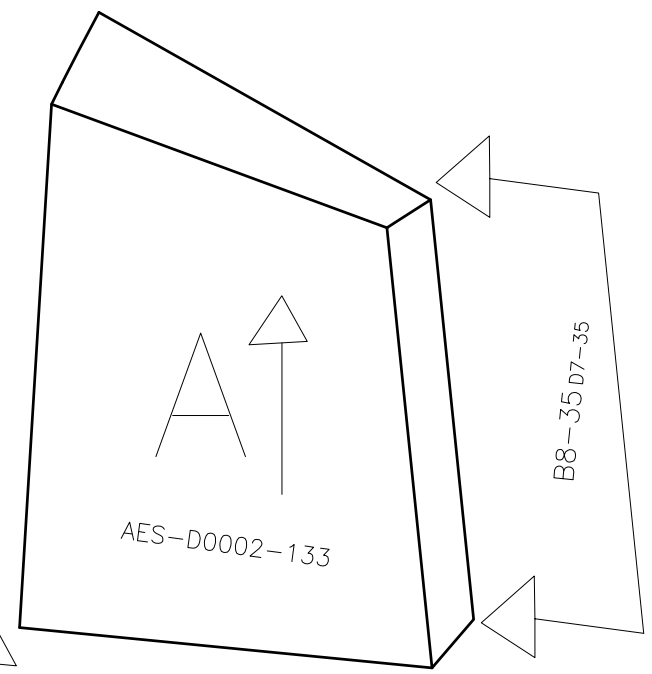
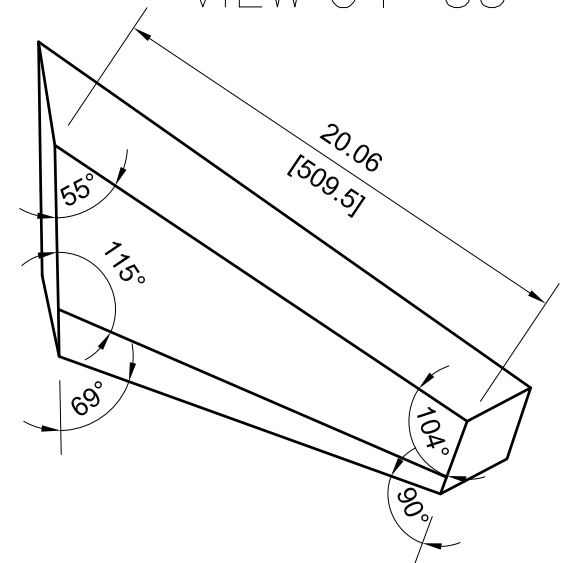

VIEW B6-35

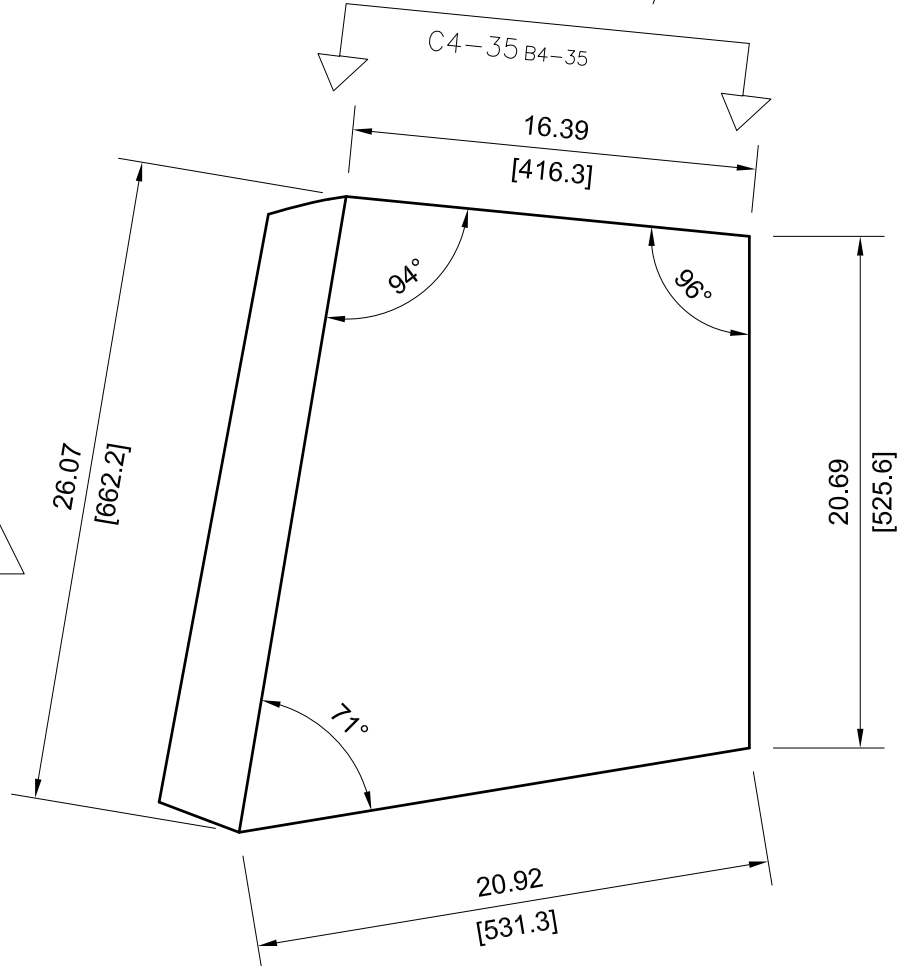
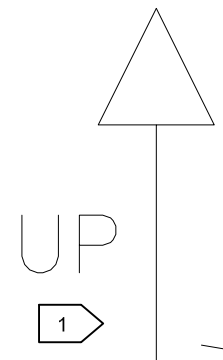

VIEW C7-35

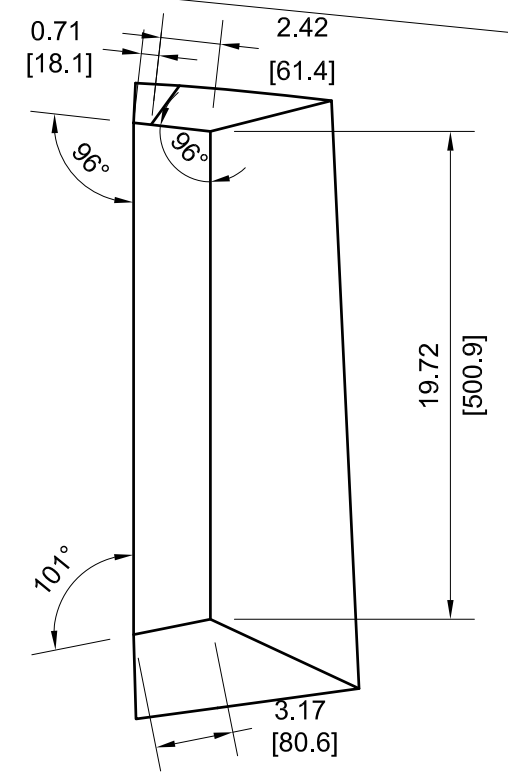

VIEW B8-35

NOTE: ALL VIEWS TAKEN AS TRUE VIEWS PARALLEL TO SURFACE OF PART

		DRAWING NUMBER			
		AES-D0002			
SIZE	SCALE	SHEET	OF	REVISION	
A3	NONE	35	167	F	

-135

VIEW C3-36

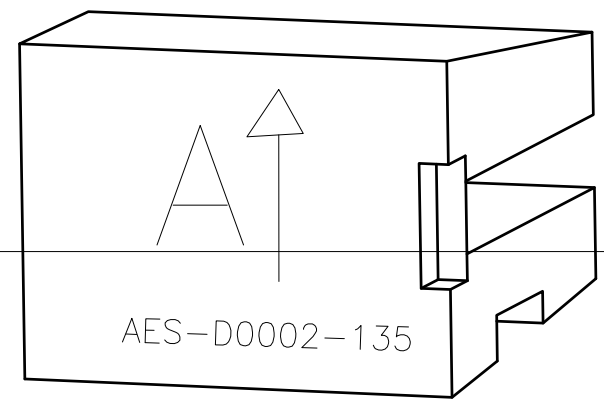
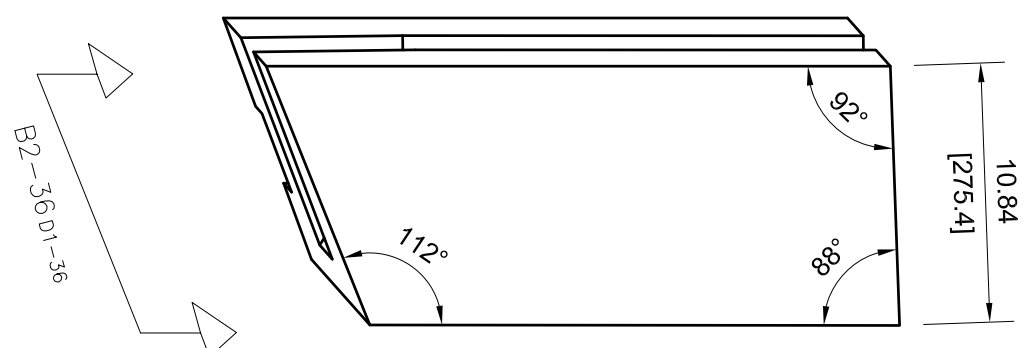

SECTION VIEW D7-36

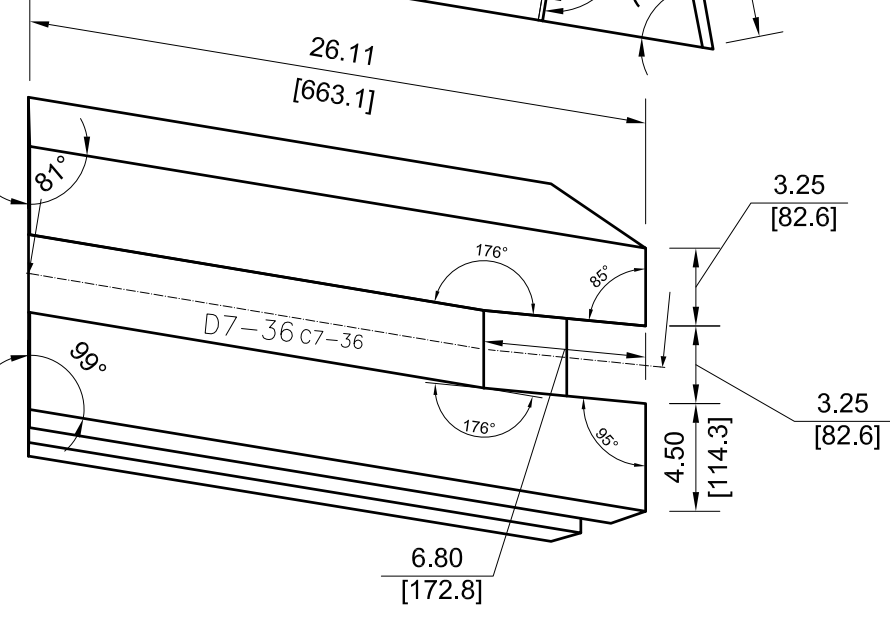
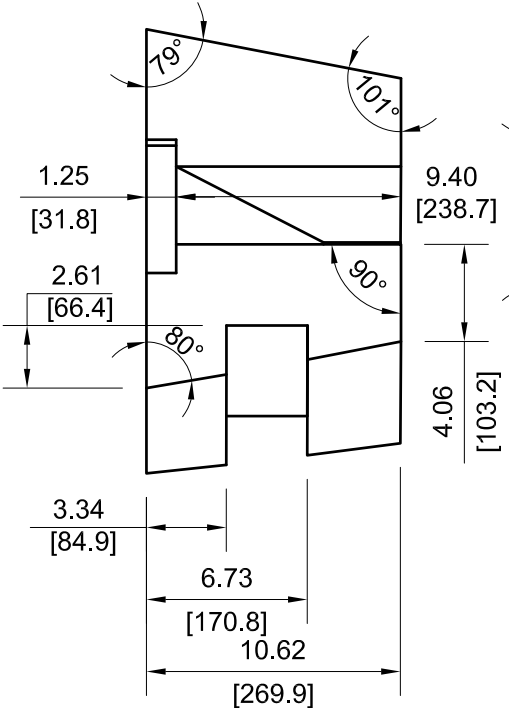
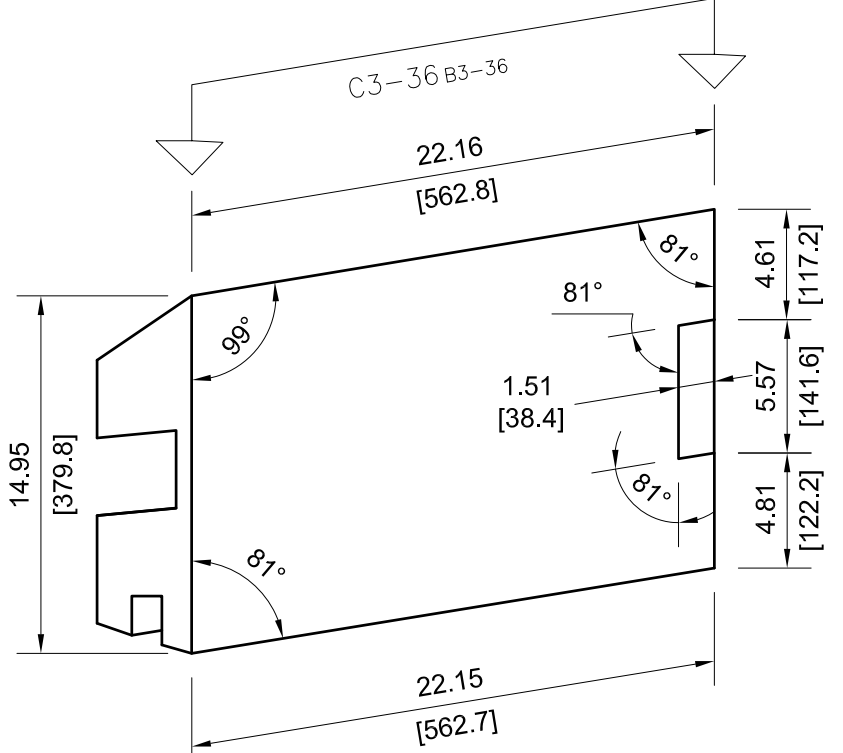
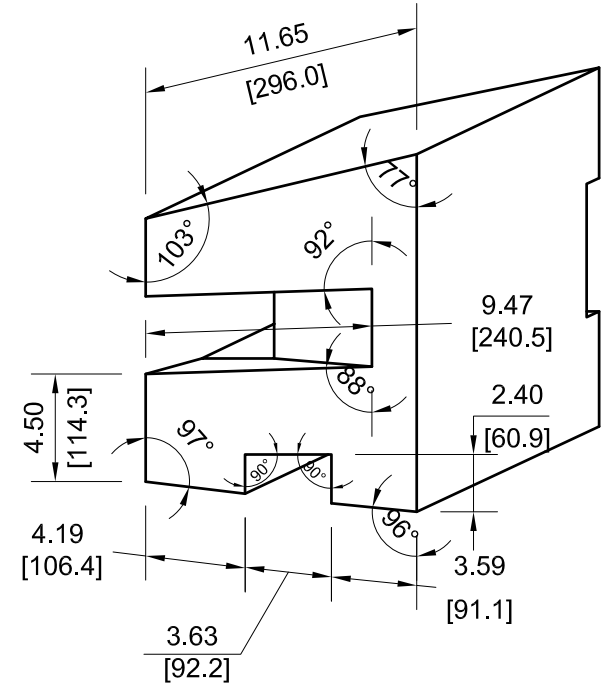
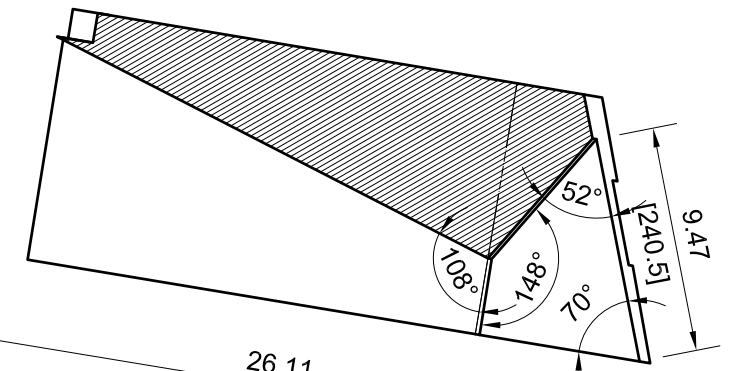

VIEW B2-36

VIEW B7-36

NOTE: ALL VIEWS TAKEN AS TRUE VIEWS PARALLEL TO SURFACE OF PART



DRAWING NUMBER					AES-D0002				
SIZE	SCALE	SHEET	OF	REVISION					
A3	NONE	36	167	F					

-137

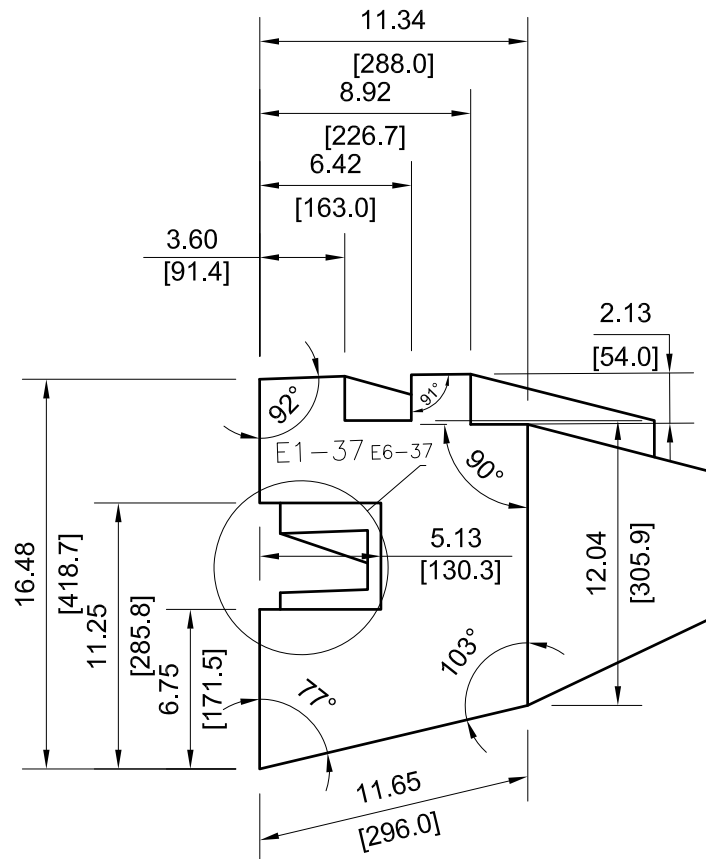

VIEW B3-37

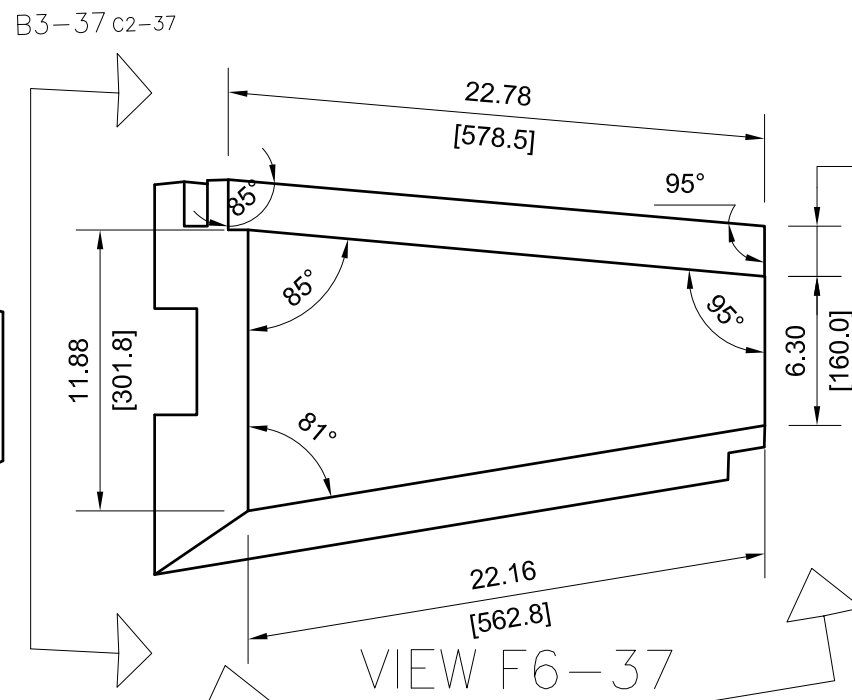

VIEW F6-37

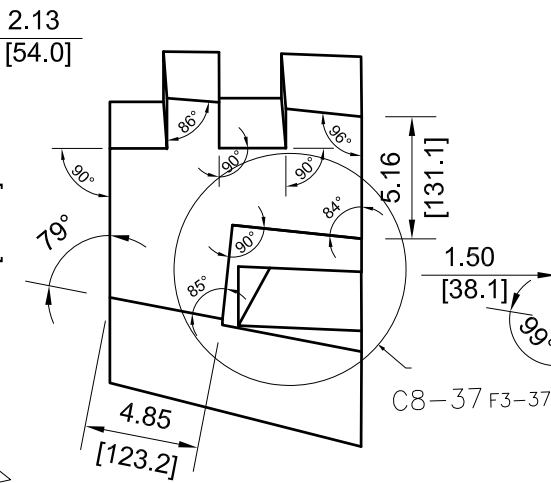

DETAIL VIEW C8-37

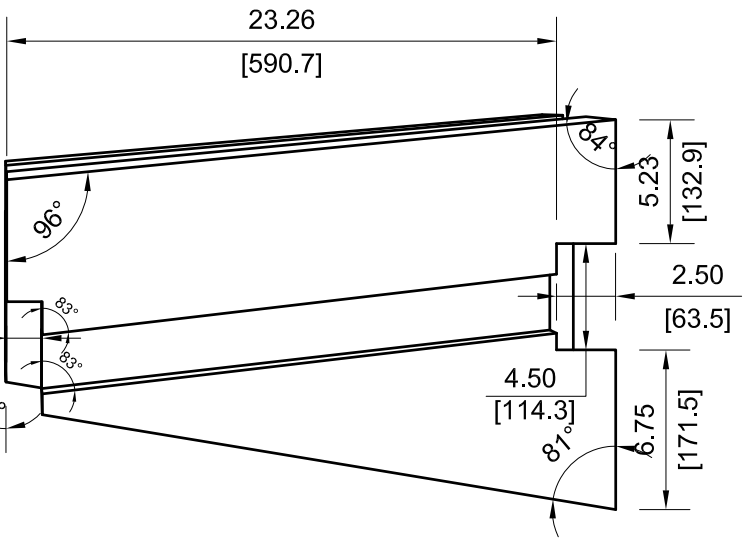

VIEW D4-37

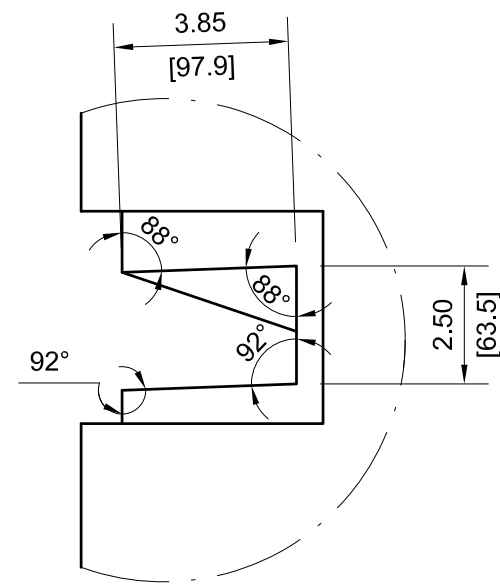

DETAIL VIEW E1-37

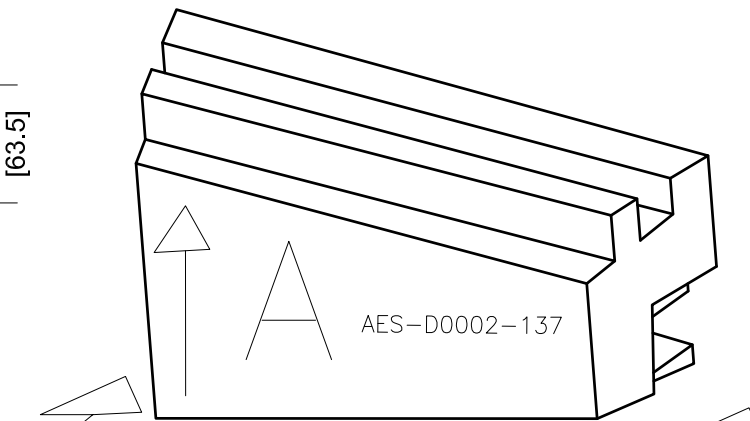
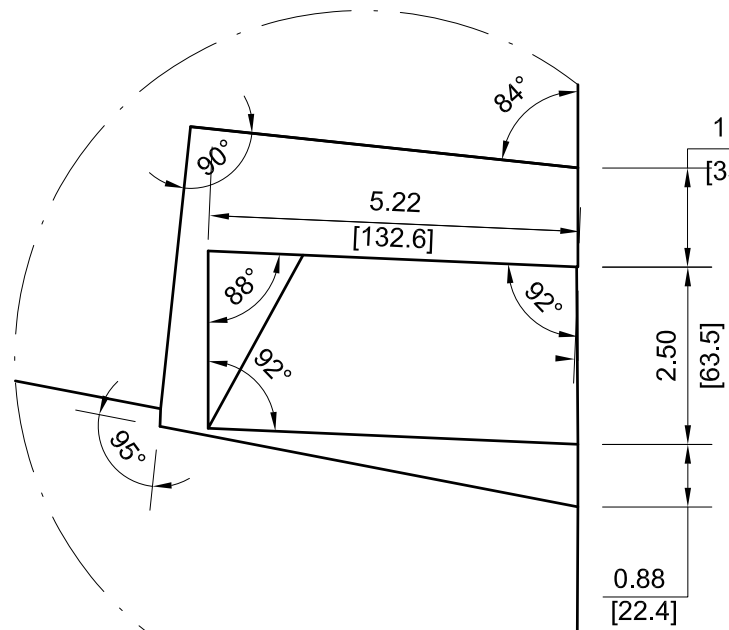

F6-37 C4-37

NOTE: ALL VIEWS TAKEN AS TRUE VIEWS PARALLEL TO SURFACE OF PART

		DRAWING NUMBER			
		AES-D0002			
SIZE	SCALE	SHEET	OF	REVISION	
A3	NONE	37	167	F	

-139

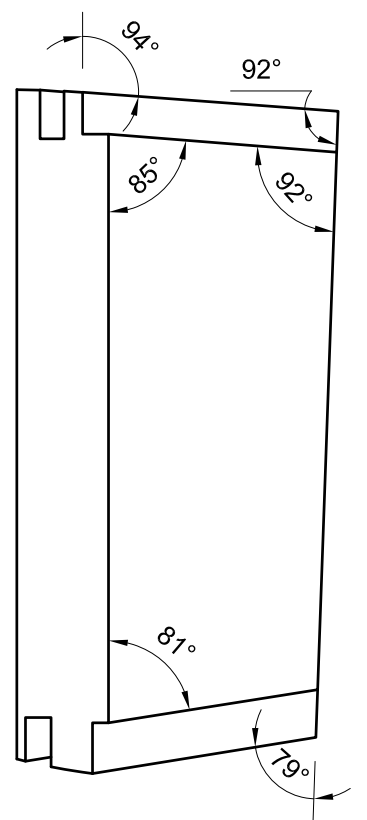
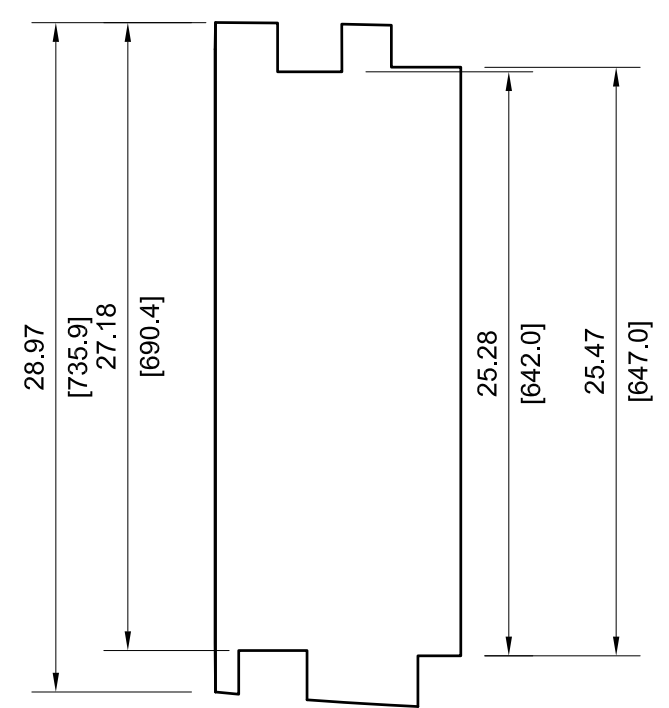
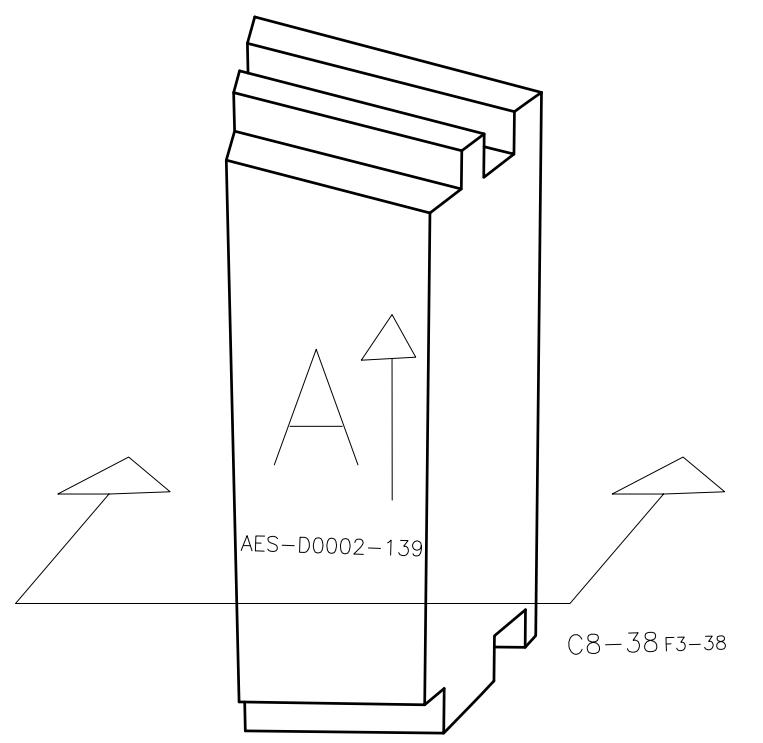
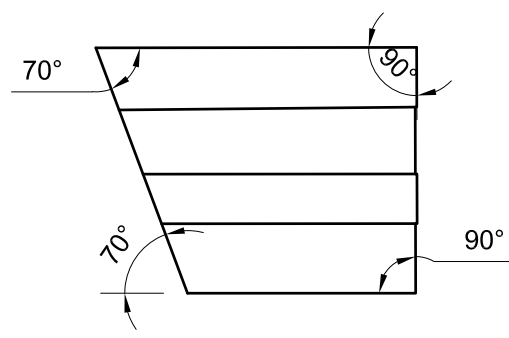

VIEW C8-38

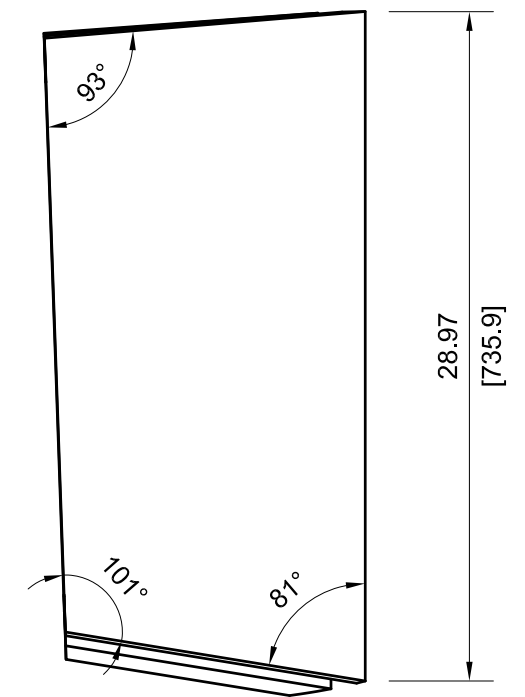
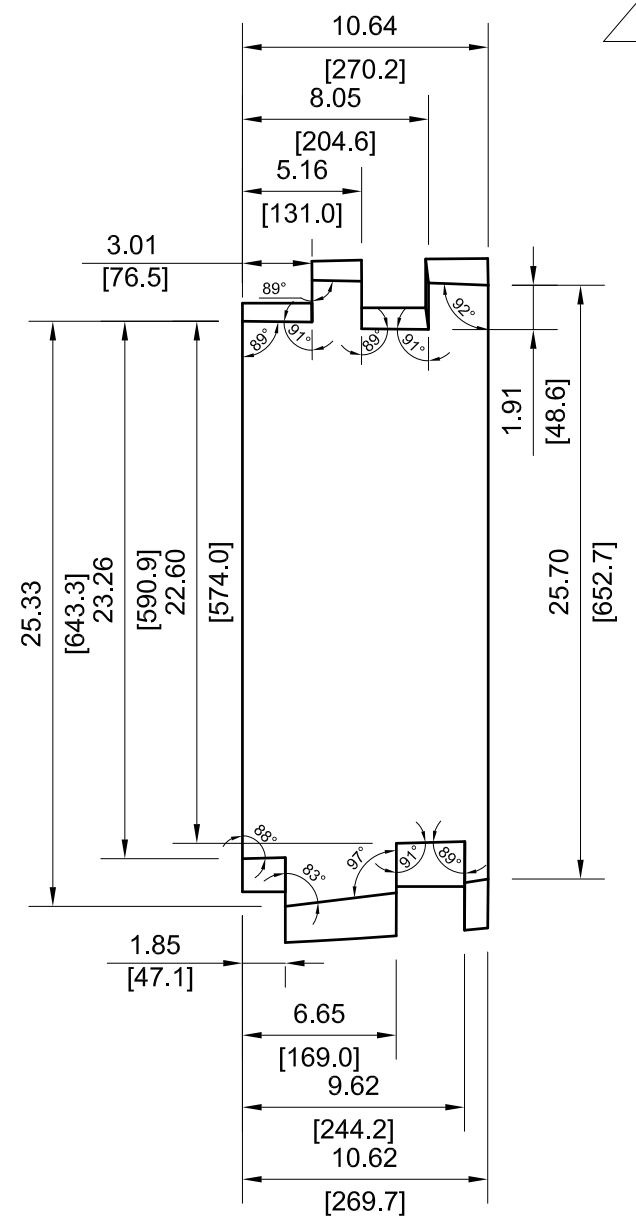

NOTE: ALL VIEWS TAKEN AS TRUE VIEWS PARALLEL TO SURFACE OF PART

	DRAWING NUMBER				
	AES-D0002				
SIZE	SCALE	SHEET	OF	REVISION	
A3	NONE	38	167	F	

— 141

VIEW B4-39

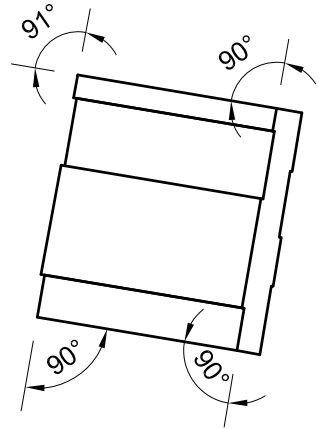

B4-39 A3-39

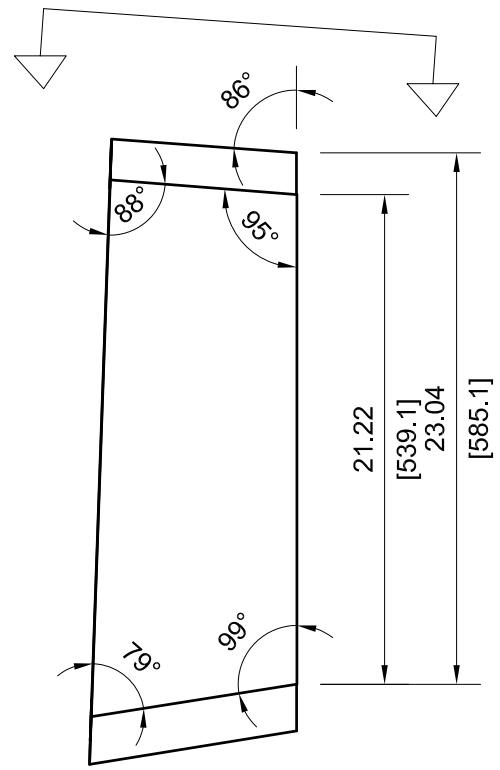
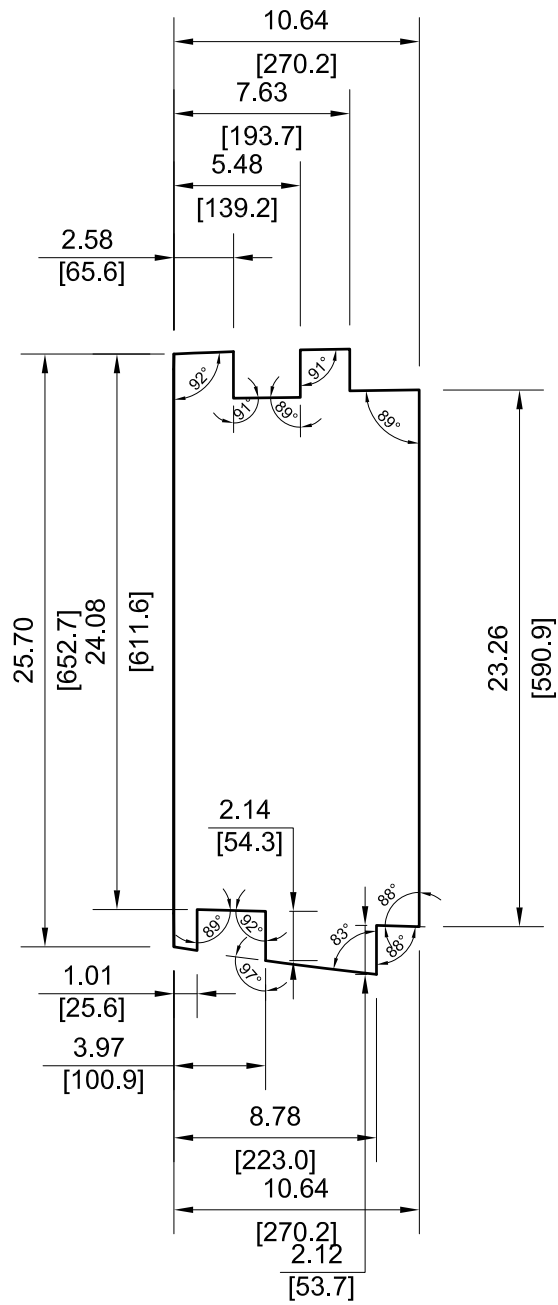
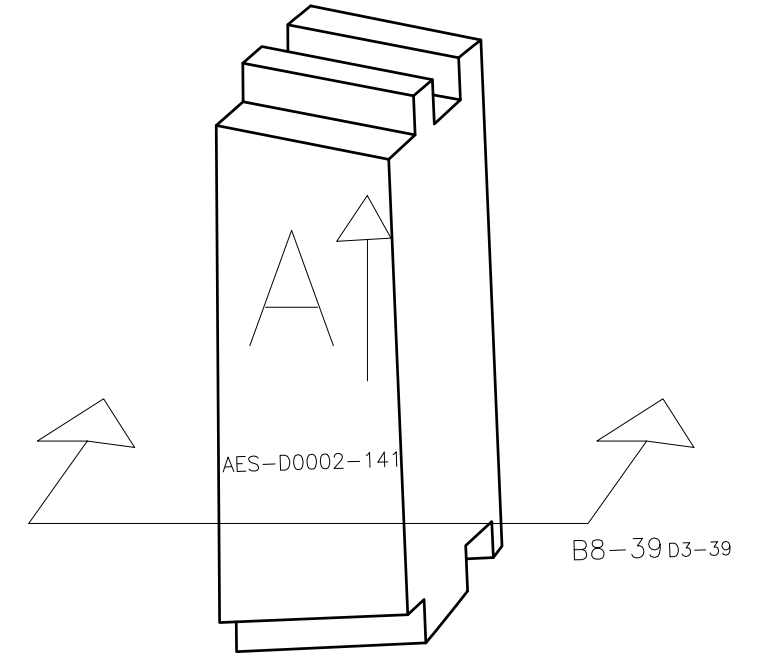

VIEW B8-39

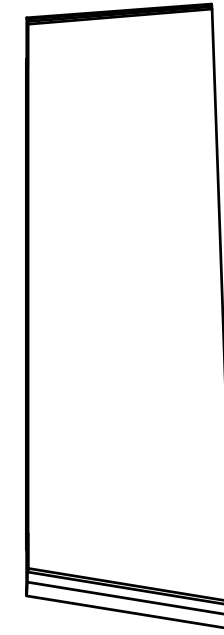
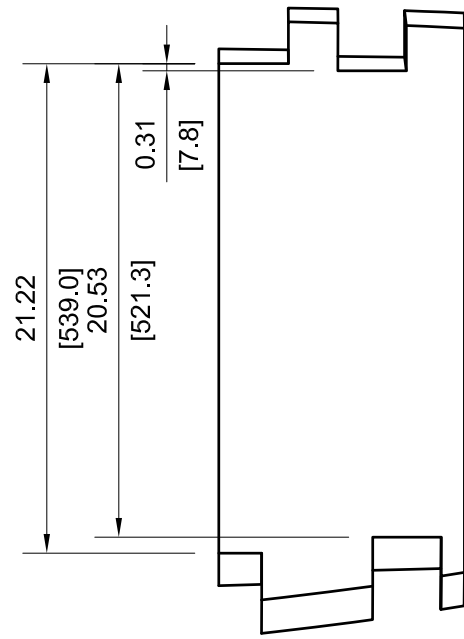

NOTE: ALL VIEWS TAKEN AS TRUE VIEWS PARALLEL TO SURFACE OF PART

	DRAWING NUMBER				
	AES-D0002				
SIZE	SCALE	SHEET	OF	REVISION	
A3	NONE	39	167	F	

-143

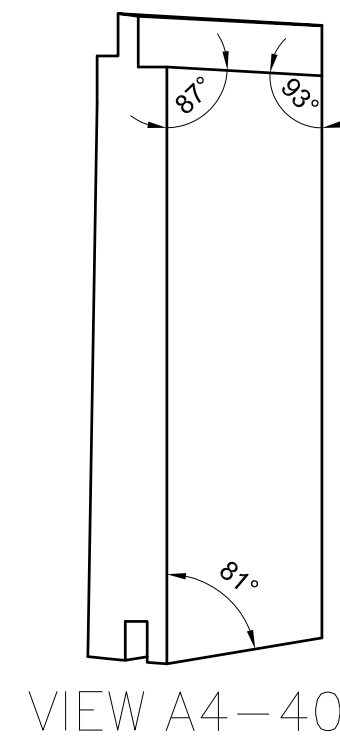
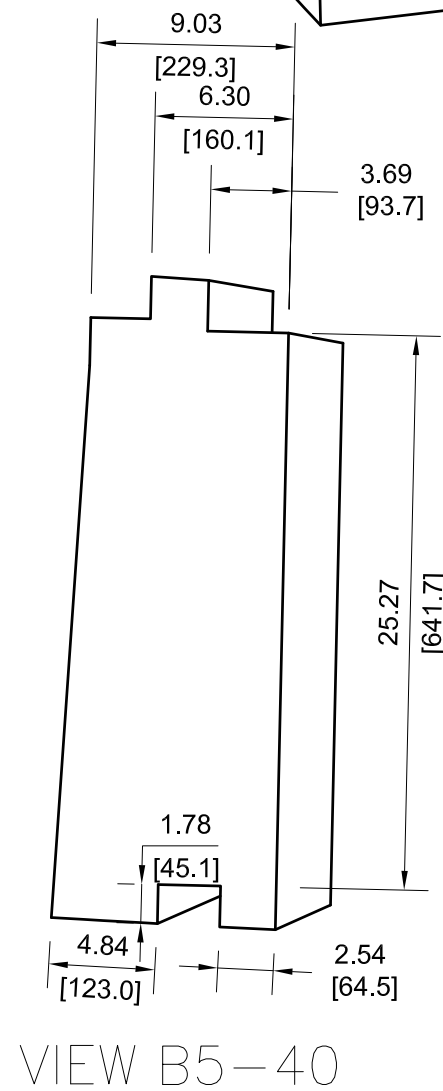
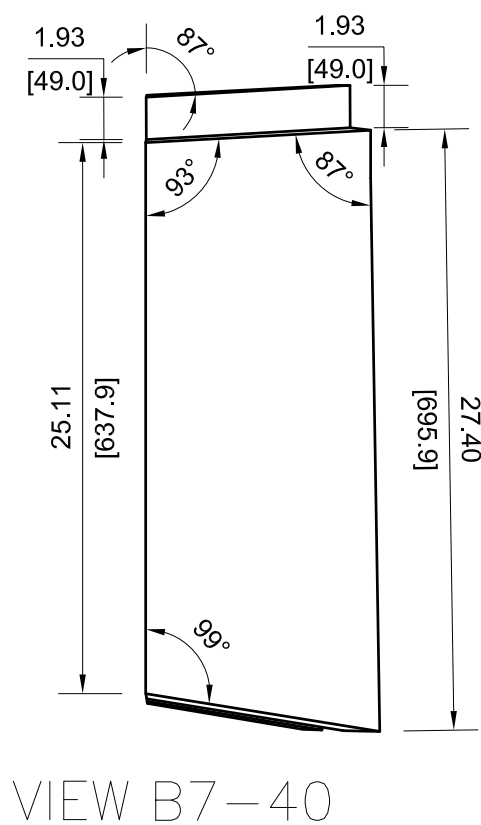
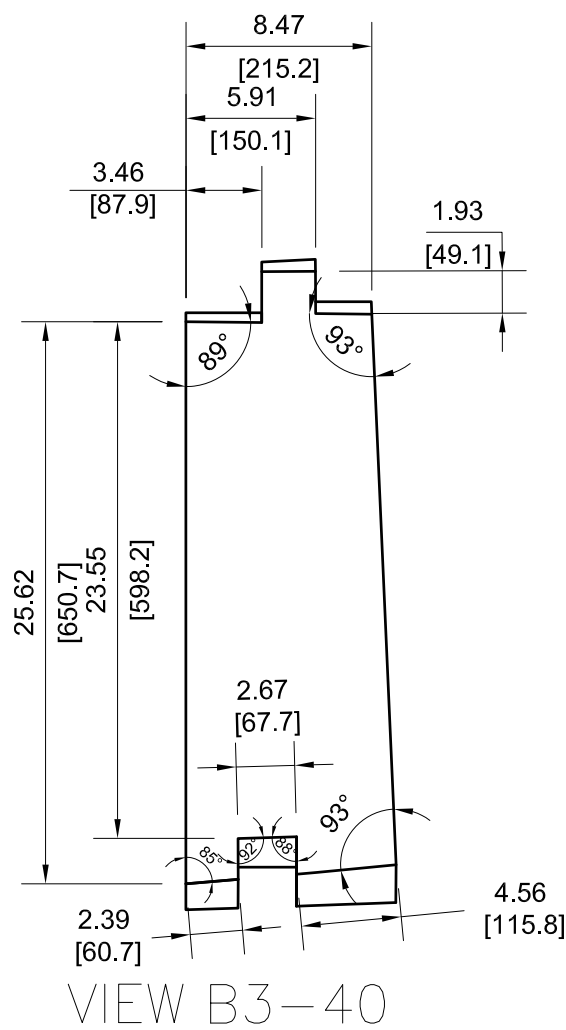
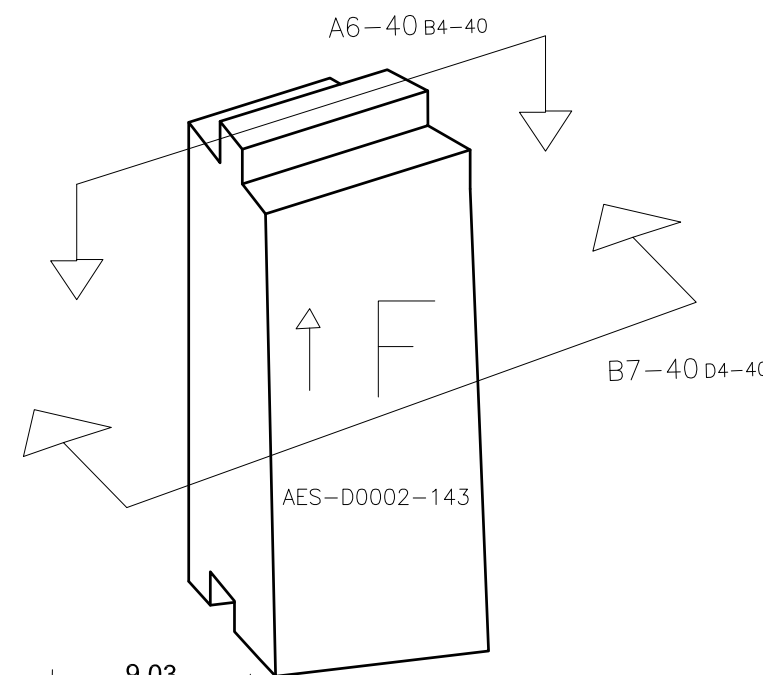
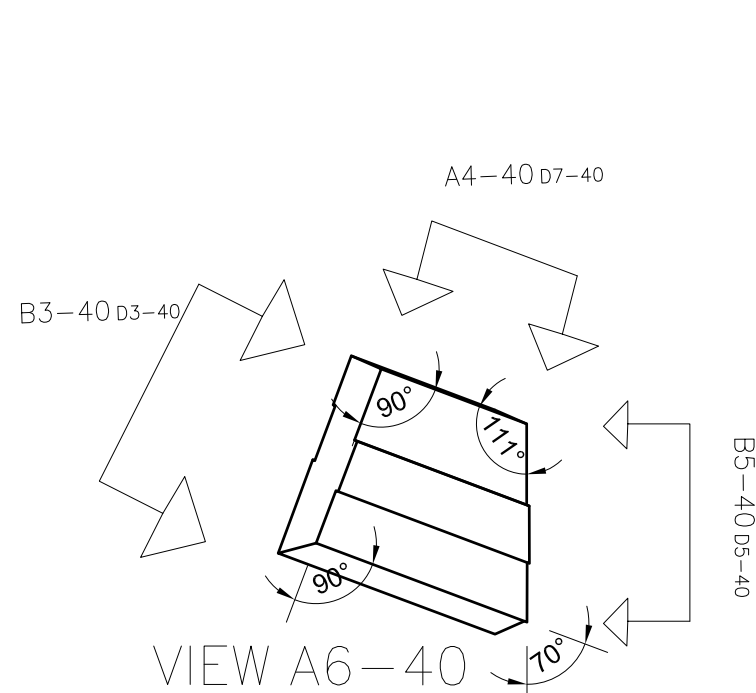

NOTE: ALL VIEWS TAKEN AS TRUE VIEWS PARALLEL TO SURFACE OF PART

	DRAWING NUMBER				
	AES-D0002				
SIZE	SCALE	SHEET	OF	REVISION	
A3	NONE	40	167	F	

-145

A6-41B4-41

A4-41D7-41

VIEW A6-41

B5-41D5-41

B3-41D3-41

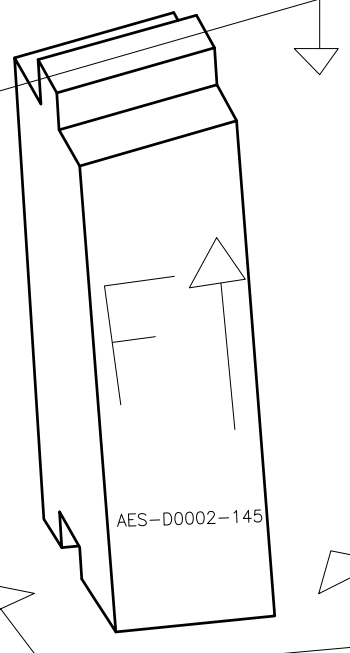

C7-41D4-41

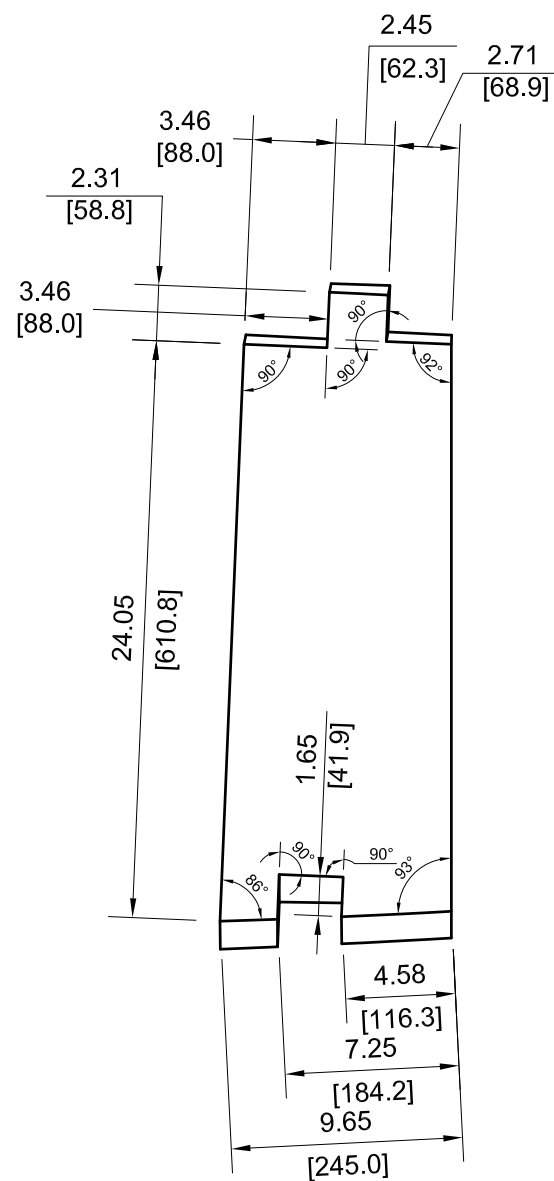

VIEW B3-41

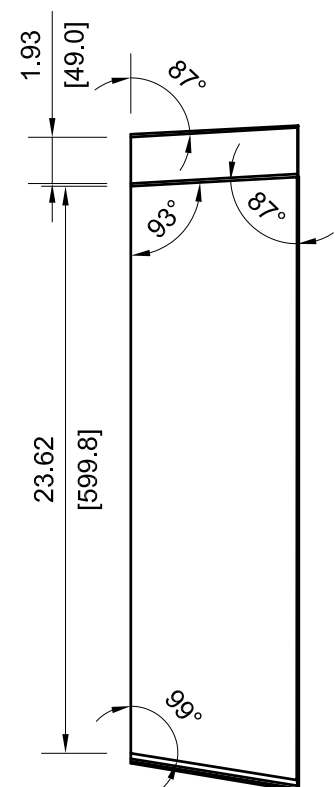

VIEW C7-41

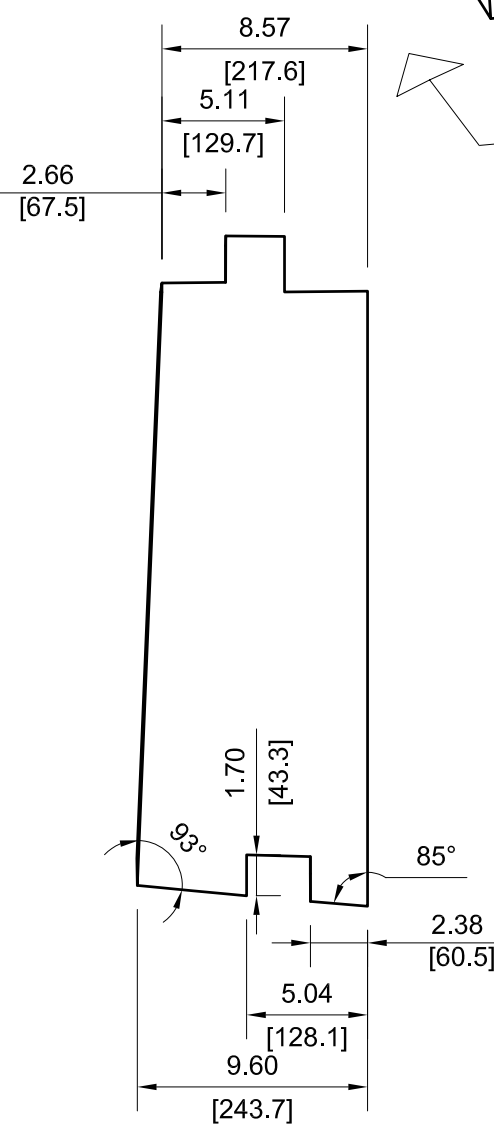

VIEW B5-41

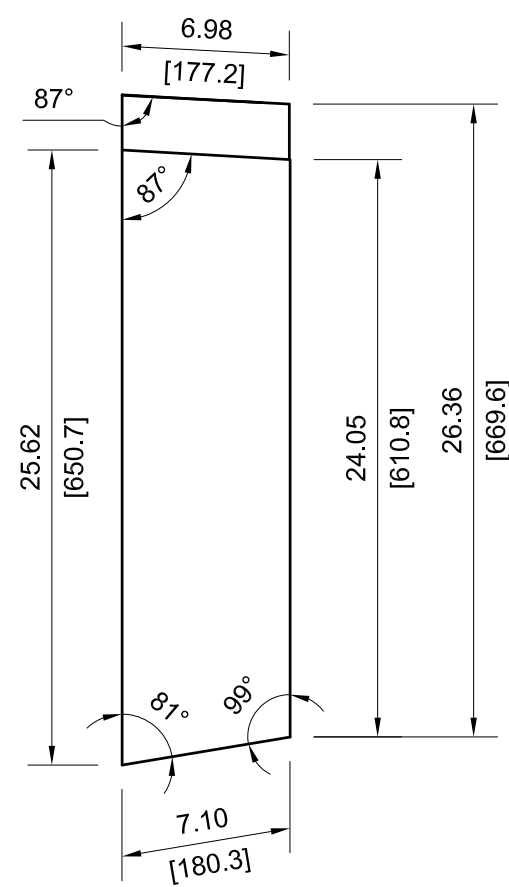

VIEW A4-41

NOTE: ALL VIEWS TAKEN AS TRUE VIEWS PARALLEL TO SURFACE OF PART

		DRAWING NUMBER			
		AES-D0002			
SIZE	SCALE	SHEET	OF	REVISION	
A3	NONE	41	167	F	

147

VIEW B8-42

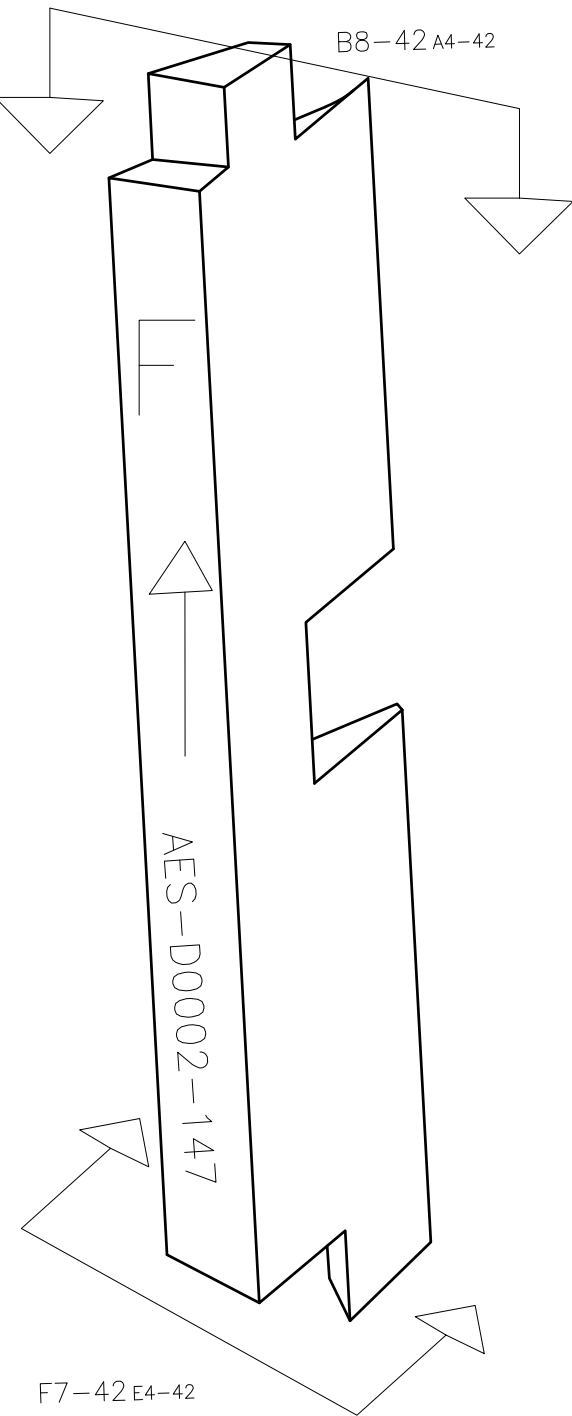
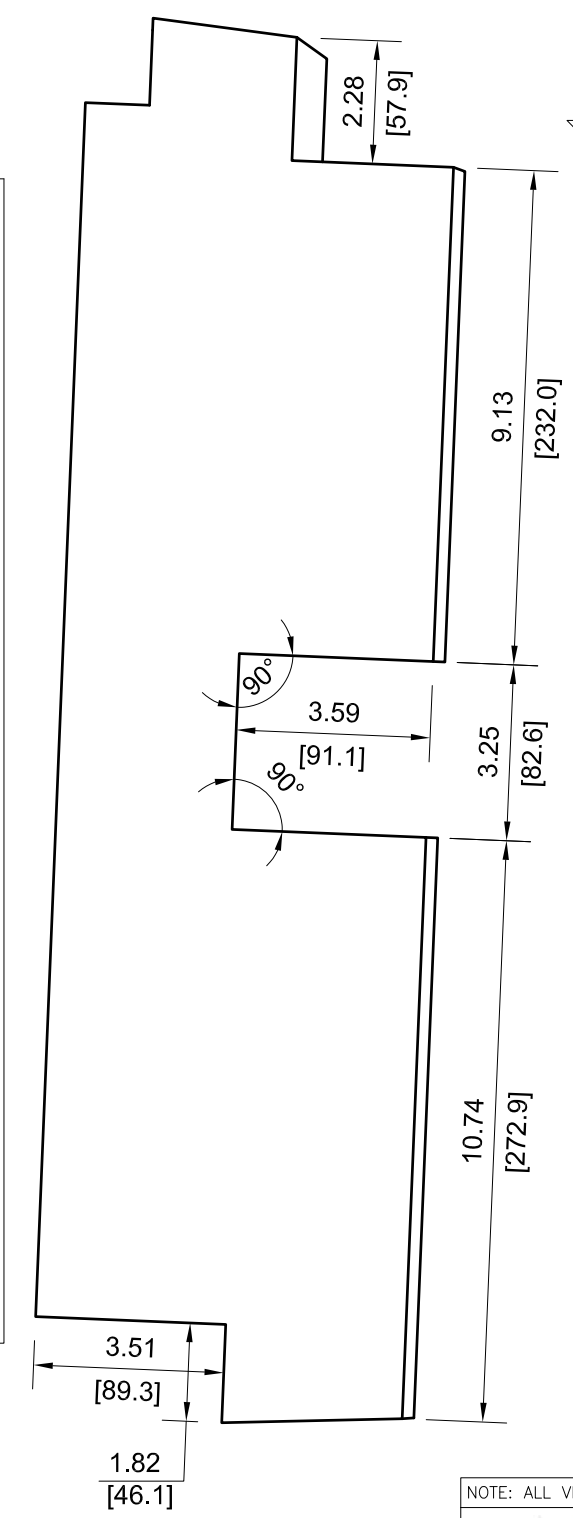
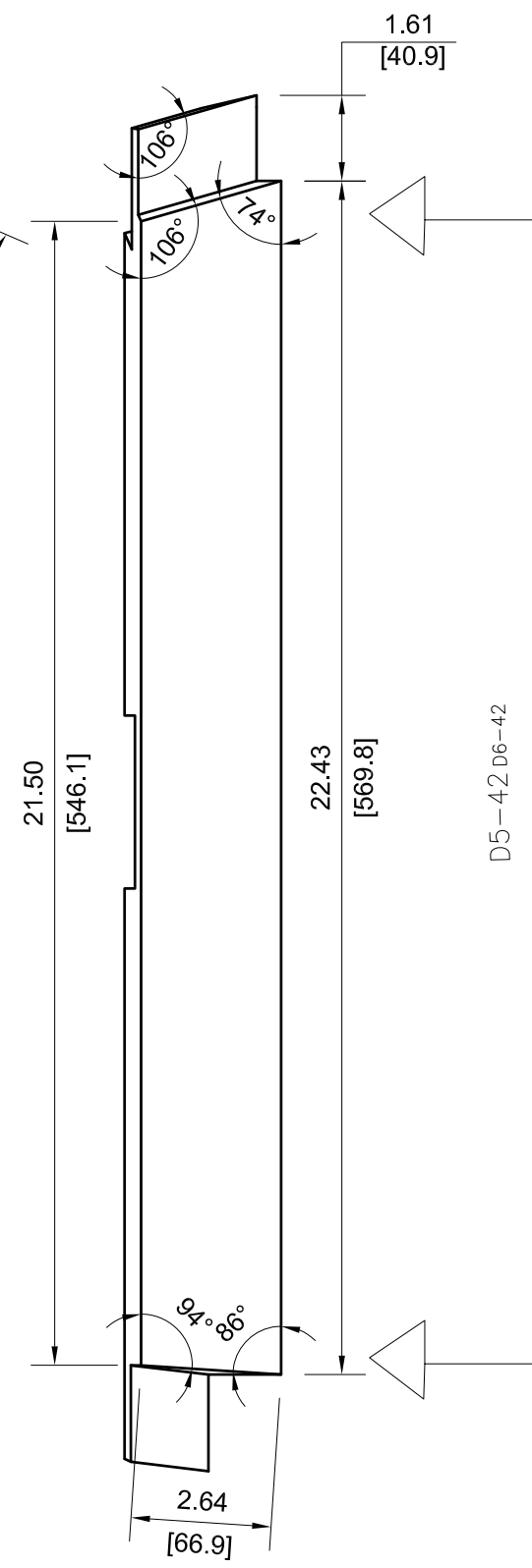
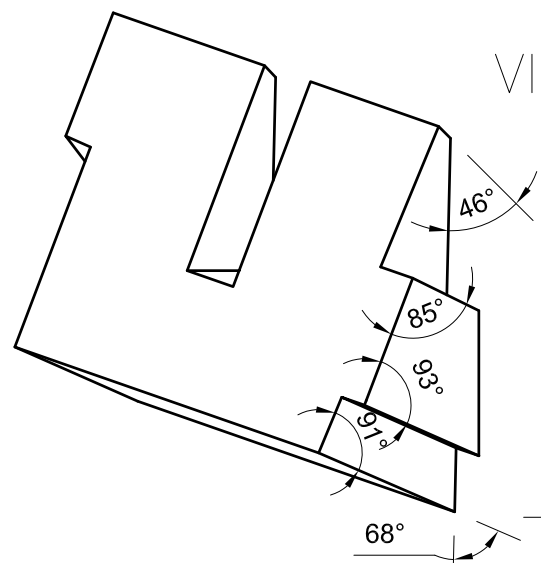
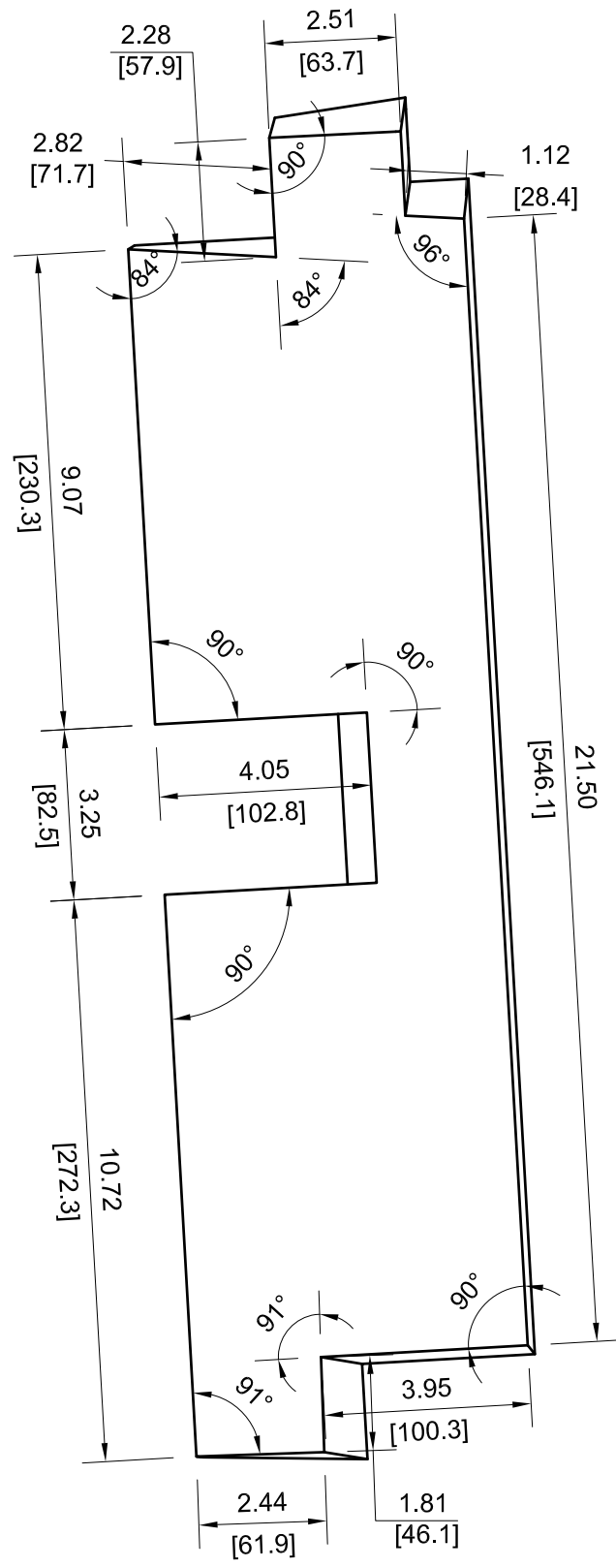

VIEW D3-42

VIEW F7-42

VIEW D5-42

NOTE: ALL VIEWS TAKEN AS TRUE VIEWS PARALLEL TO SURFACE OF PART

DRAWING NUMBER		AES-D0002		
SIZE	SCALE	SHEET	OF	REVISION
A3	NONE	42	167	F

- 149

VIEW F4-43

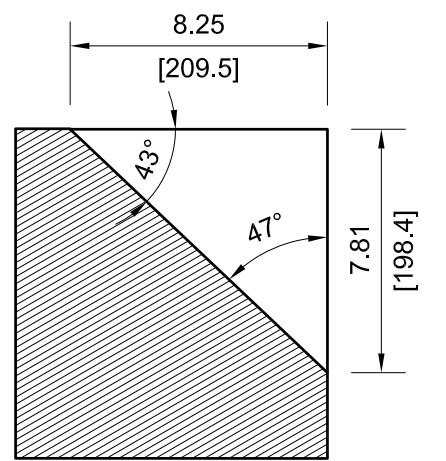
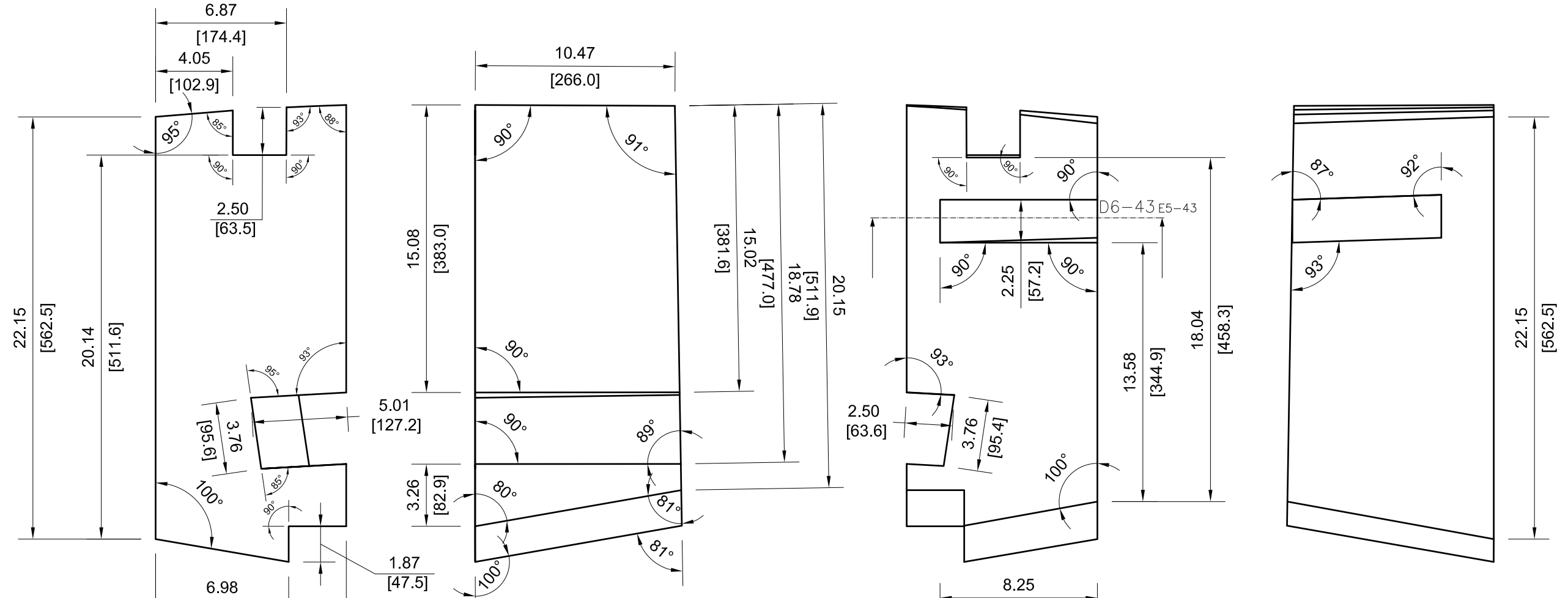

SECTION VIEW D6-43

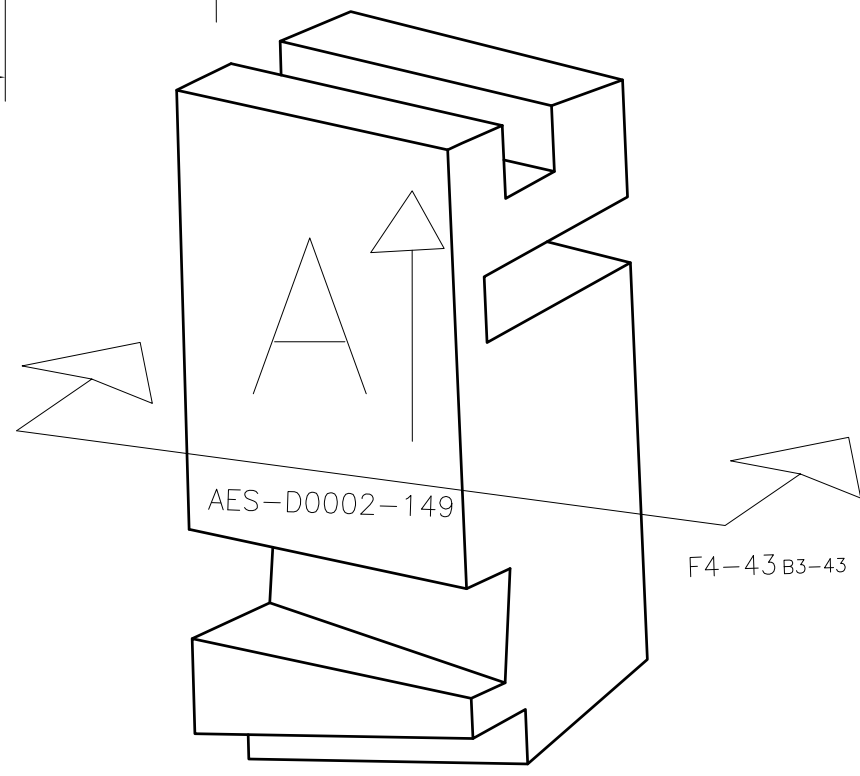

NOTE: ALL VIEWS TAKEN AS TRUE VIEWS PARALLEL TO SURFACE OF PART

		DRAWING NUMBER			
		AES-D0002			
SIZE	SCALE	SHEET	OF	REVISION	
A3	NONE	43	167	F	

-151

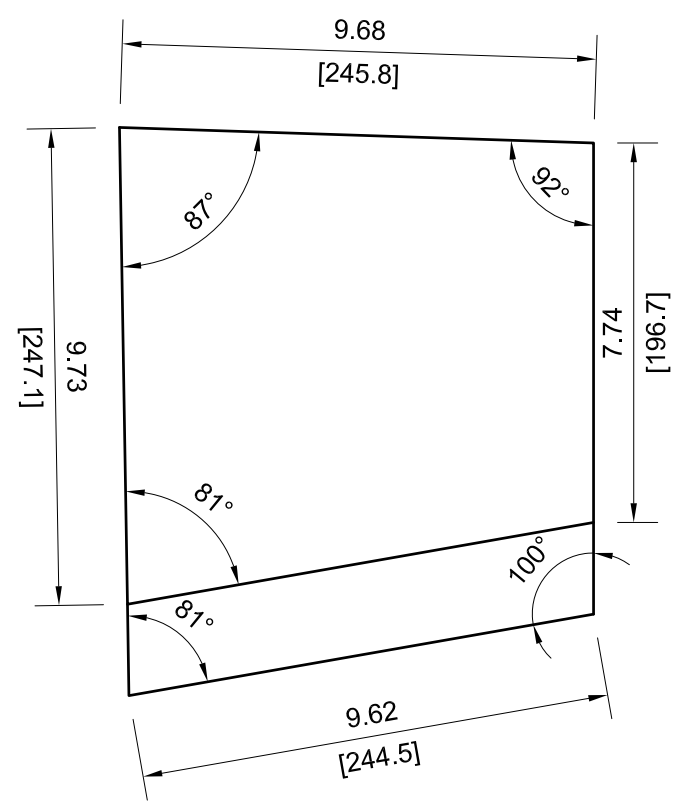
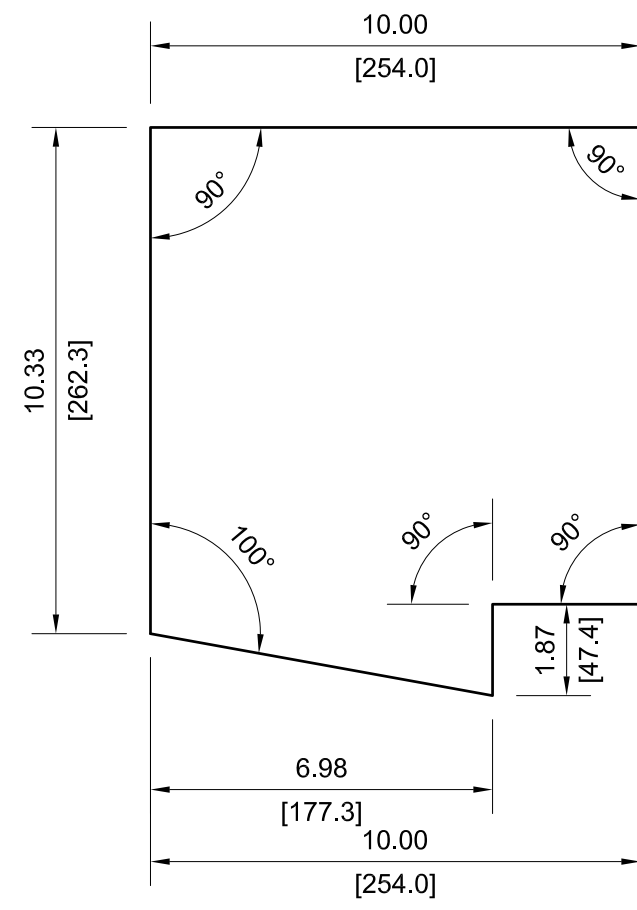

VIEW F7-44

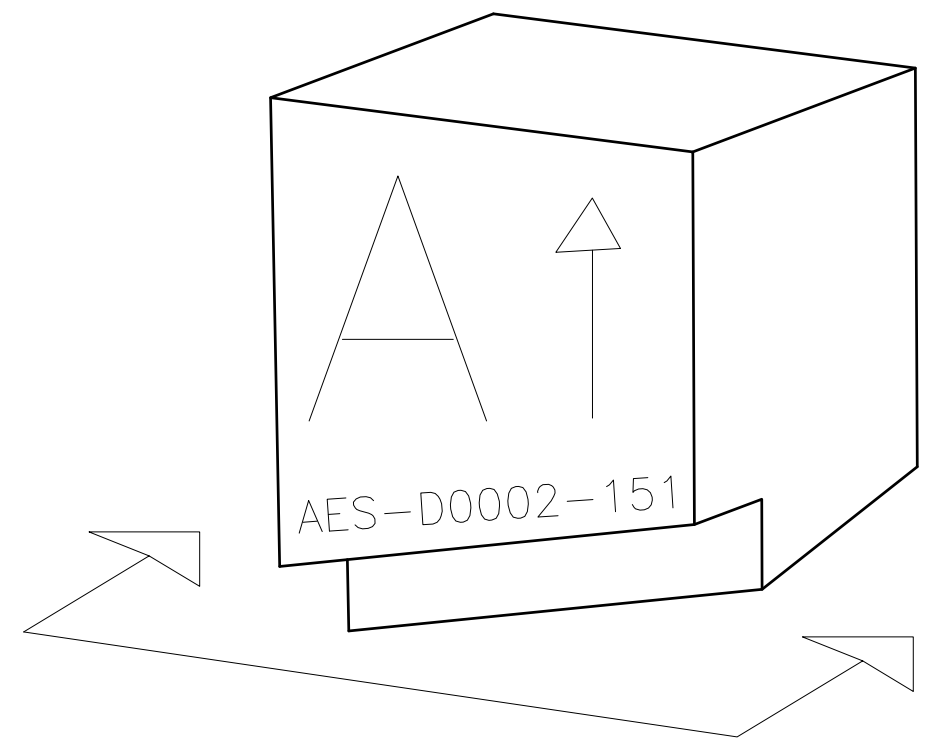
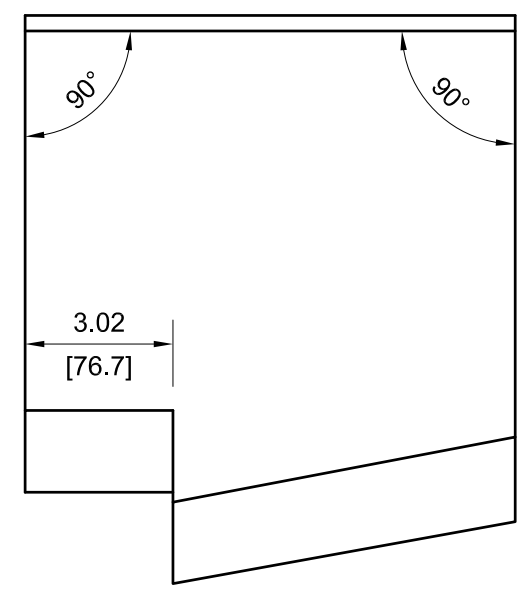

F7-44 C5-44

NOTE: ALL VIEWS TAKEN AS TRUE VIEWS PARALLEL TO SURFACE OF PART

	DRAWING NUMBER			
	AES-D0002			
SIZE	SCALE	SHEET	OF	REVISION
A3	NONE	44	167	F

-153

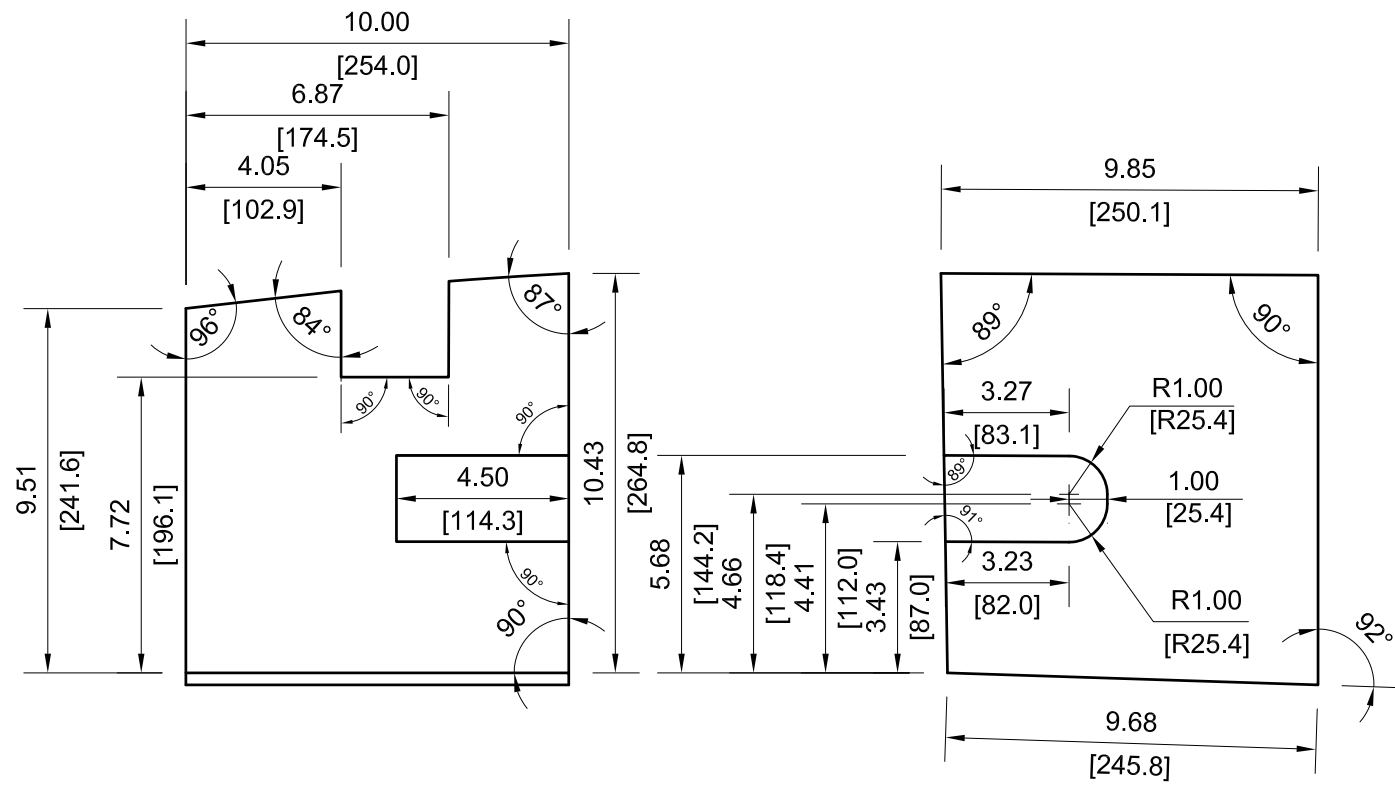

VIEW E8-45

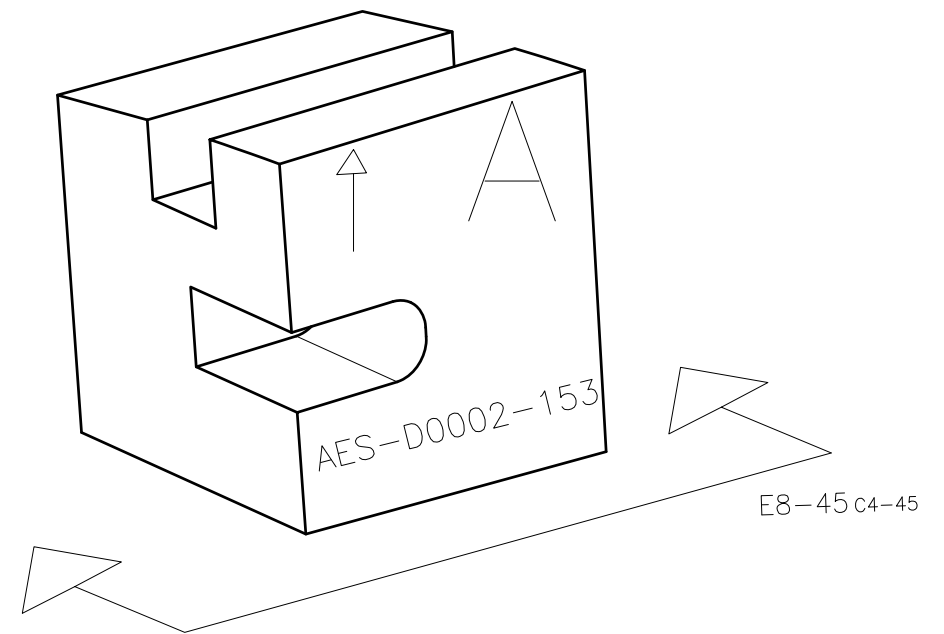
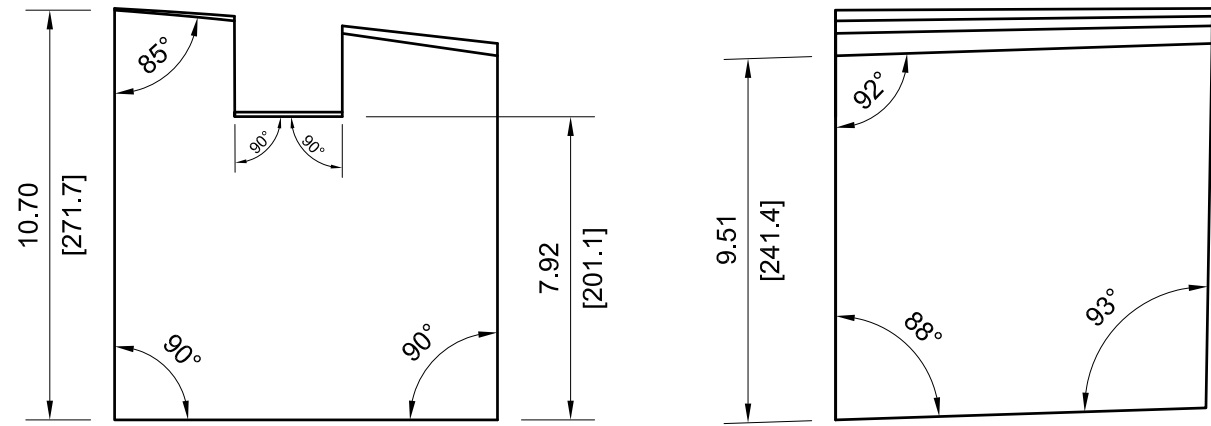

NOTE: ALL VIEWS TAKEN AS TRUE VIEWS PARALLEL TO SURFACE OF PART

	DRAWING NUMBER				AES-D0002
	SIZE	SCALE	SHEET	OF	
A3	NONE	45	167	F	

-155

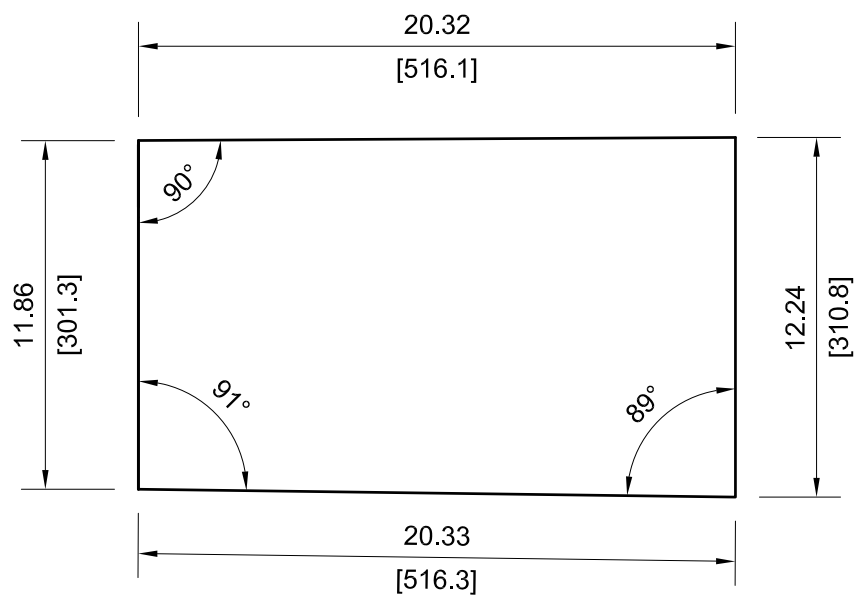
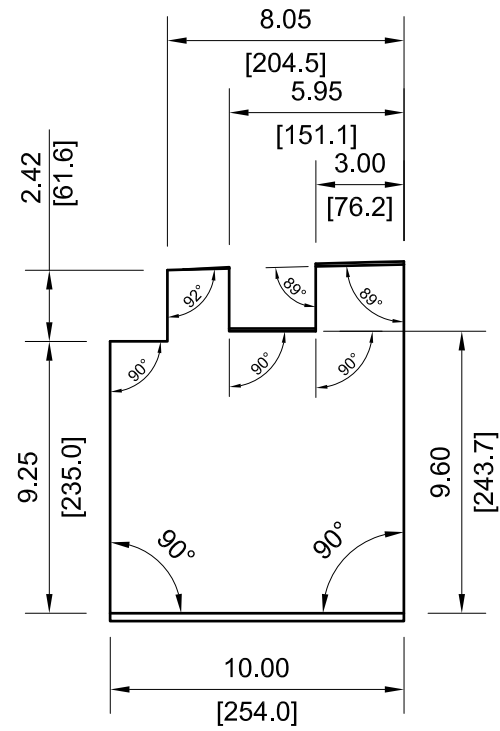

VIEW F8-46

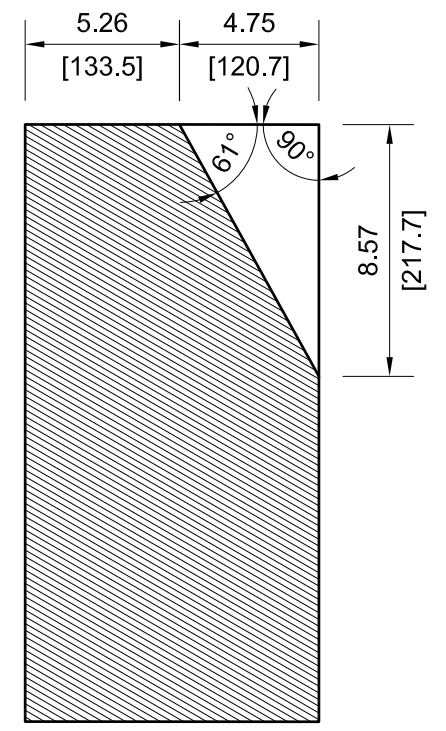
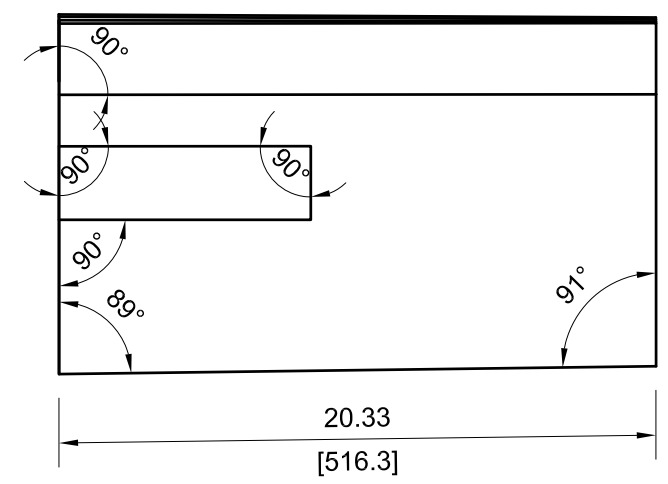
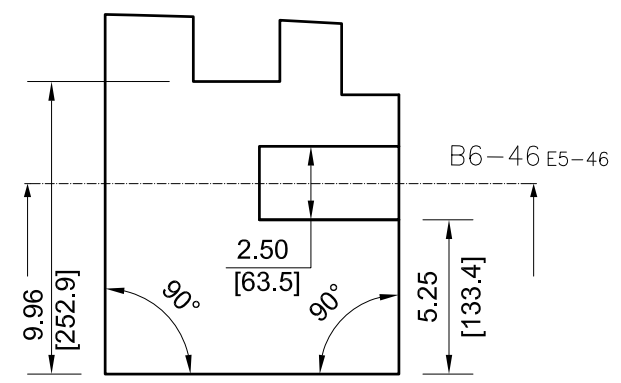

SECTION VIEW B6-46

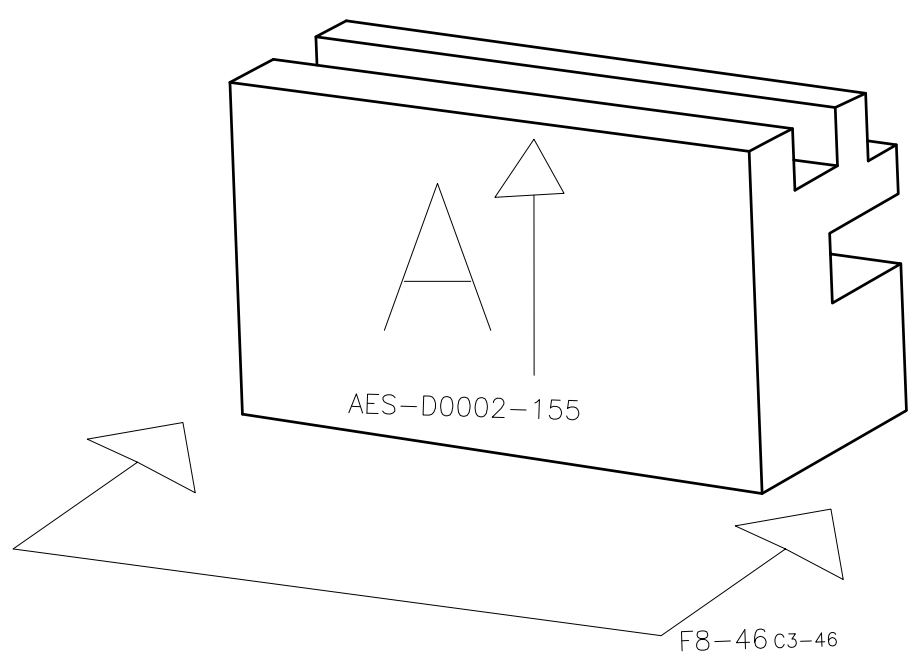

NOTE: ALL VIEWS TAKEN AS TRUE VIEWS PARALLEL TO SURFACE OF PART

	DRAWING NUMBER				AES-D0002
	SIZE	SCALE	SHEET	OF	REVISION
A3	NONE	46	167	F	

-157

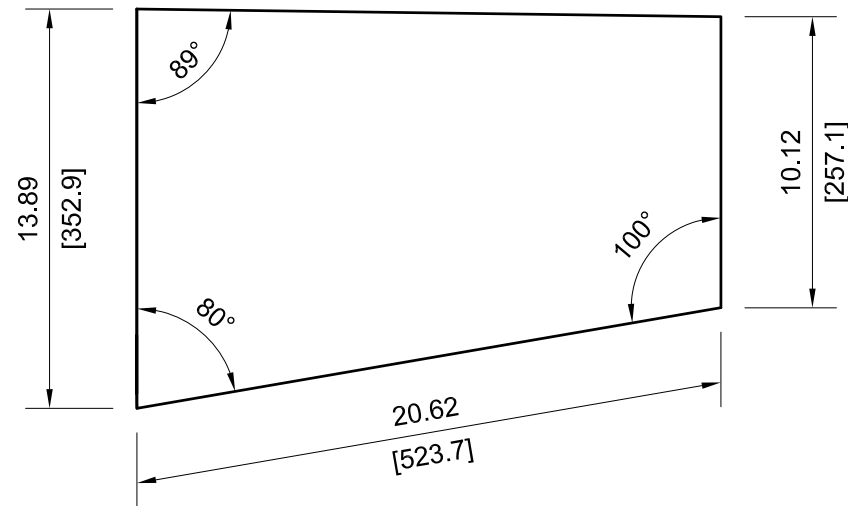
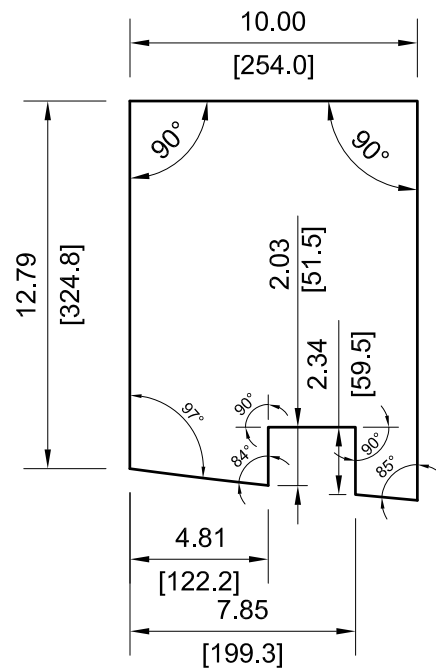

VIEW F8-47

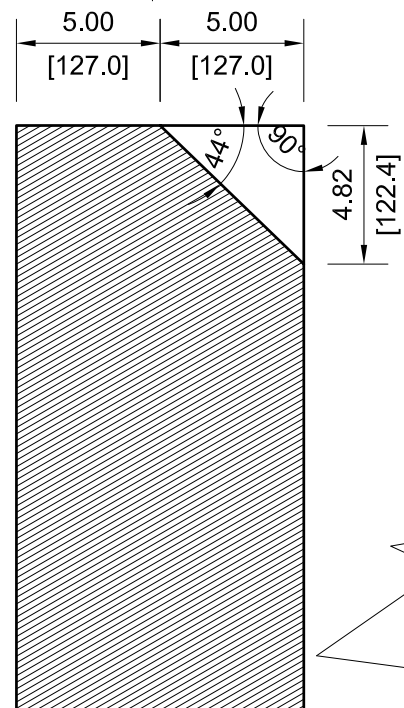
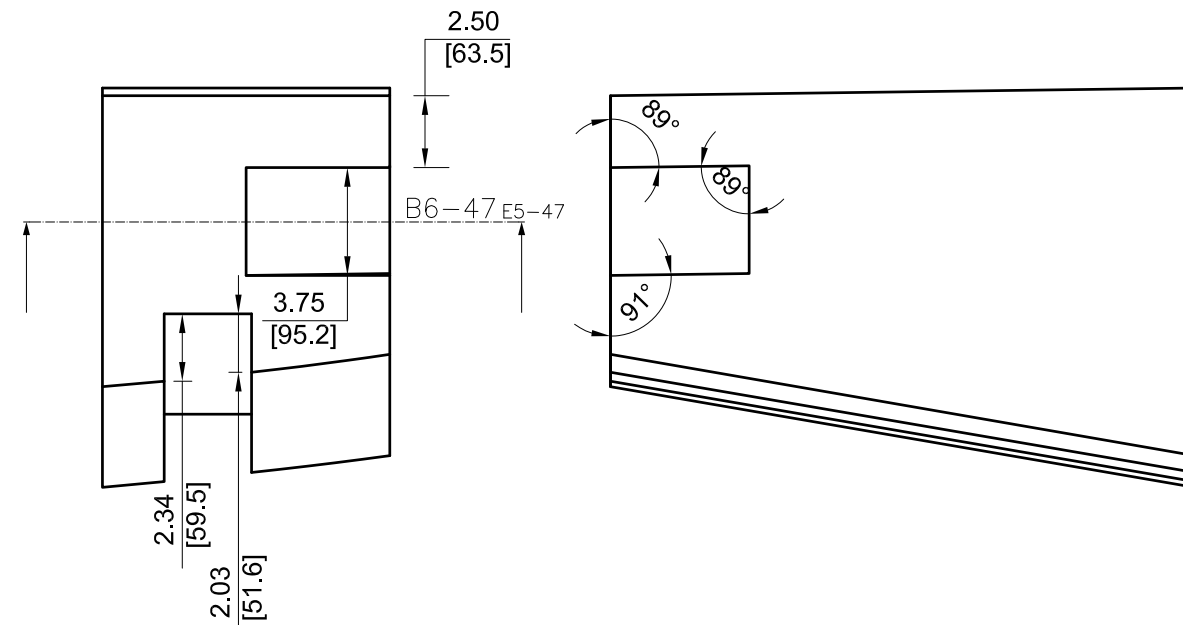

SECTION VIEW B6-47

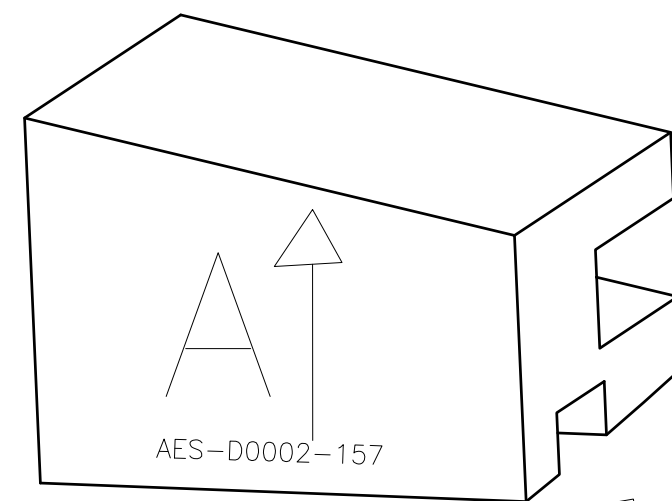

F8-47 C3-47

NOTE: ALL VIEWS TAKEN AS TRUE VIEWS PARALLEL TO SURFACE OF PART

		DRAWING NUMBER			
		AES-D0002			
SIZE	SCALE	SHEET	OF	REVISION	
A3	NONE	47	167	F	

- 159

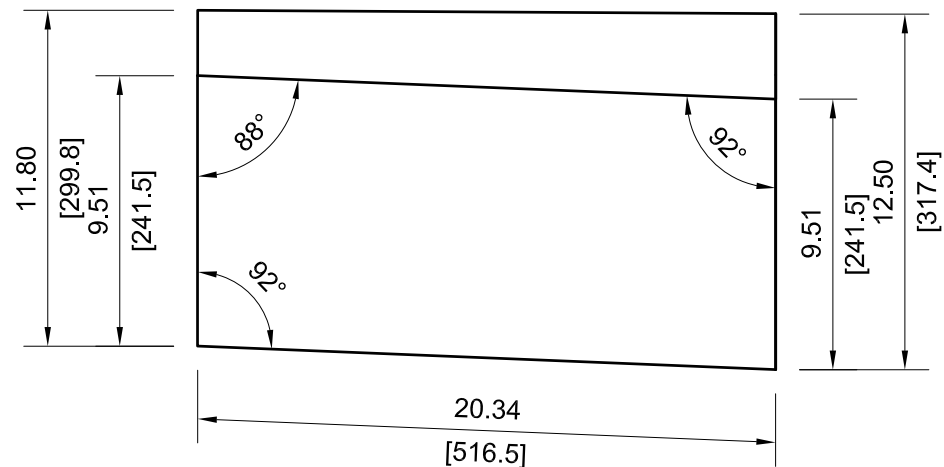
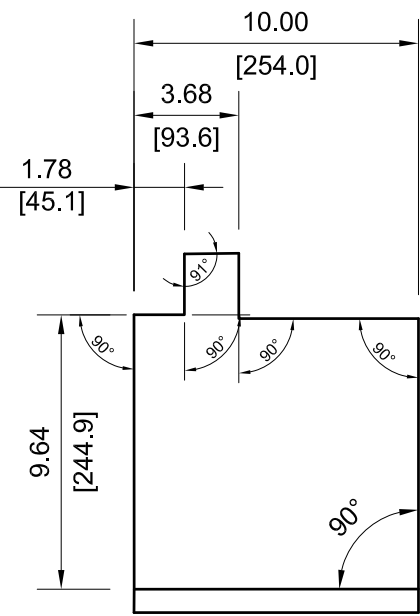

VIEW F7-48

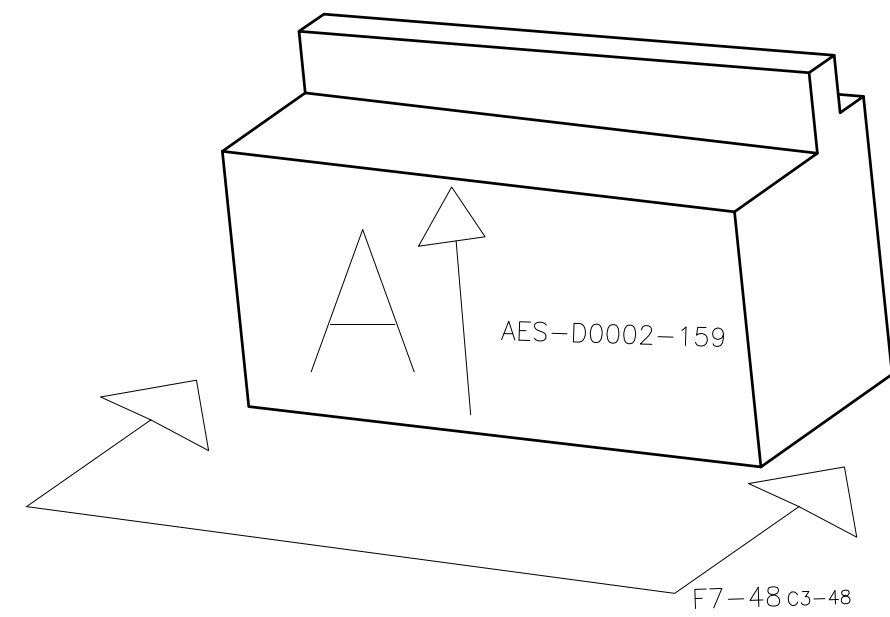
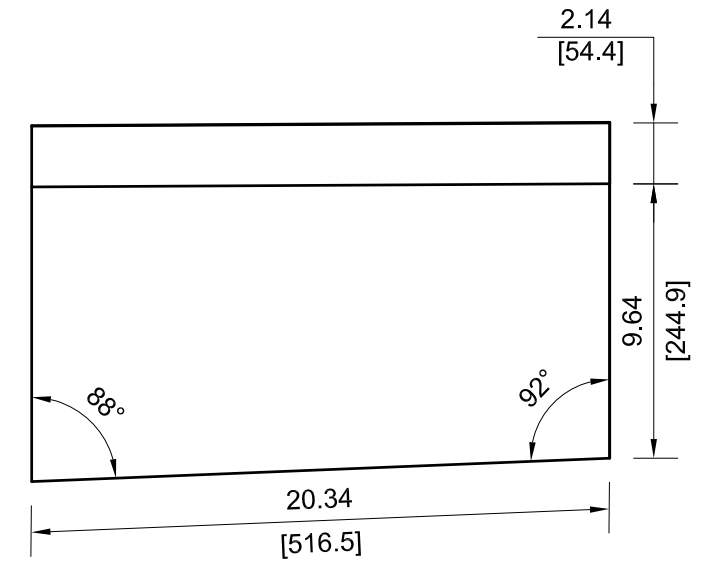
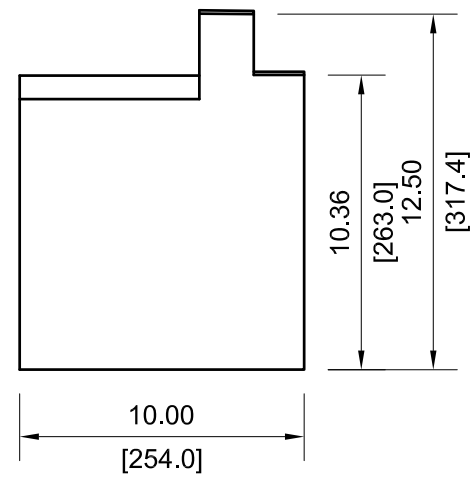

NOTE: ALL VIEWS TAKEN AS TRUE VIEWS PARALLEL TO SURFACE OF PART

		DRAWING NUMBER			
		AES-D0002			
SIZE	SCALE	SHEET	OF	REVISION	
A3	NONE	48	167	F	

- 161

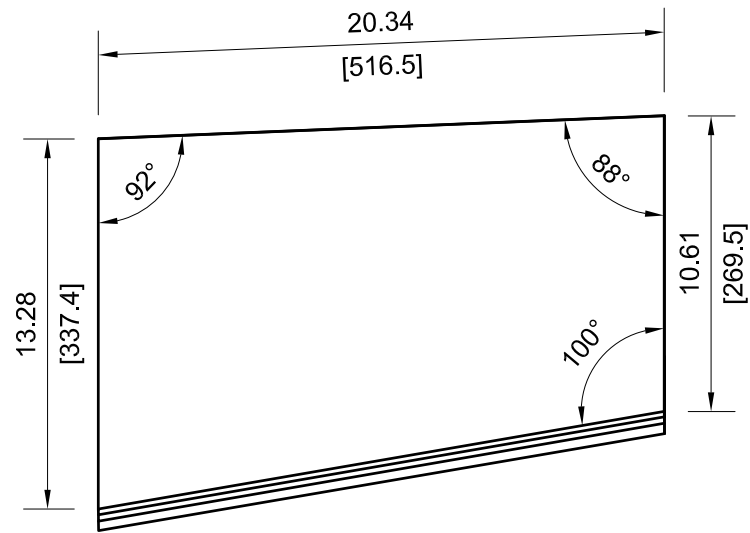
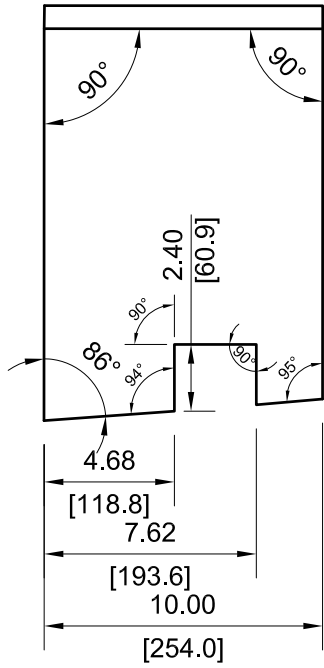

VIEW F7-49

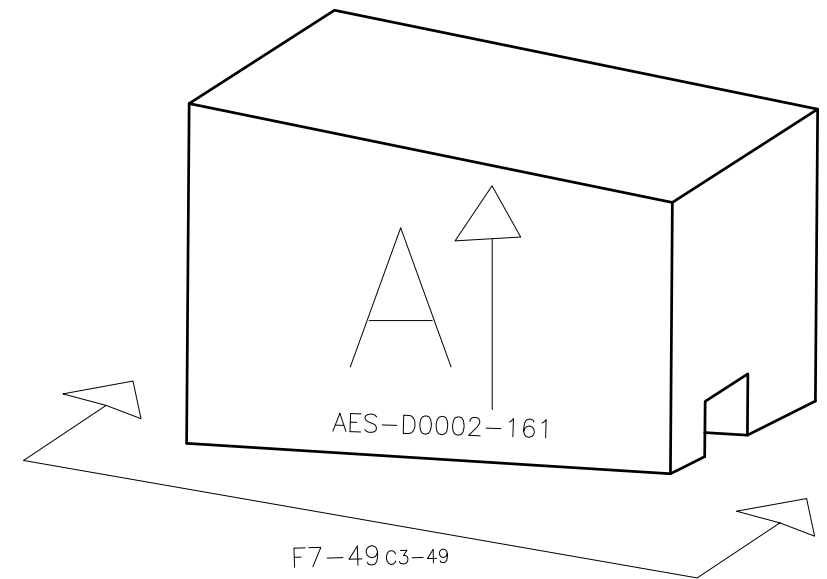
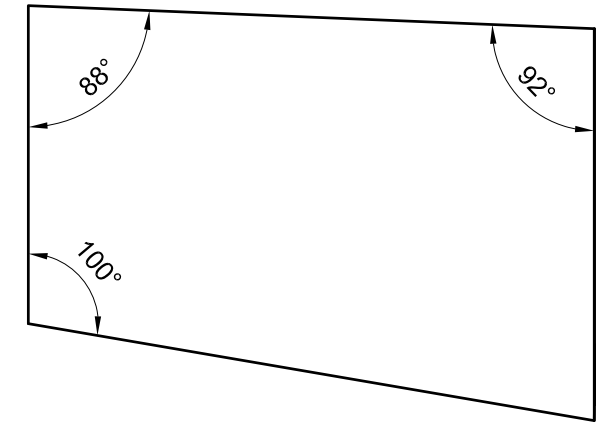
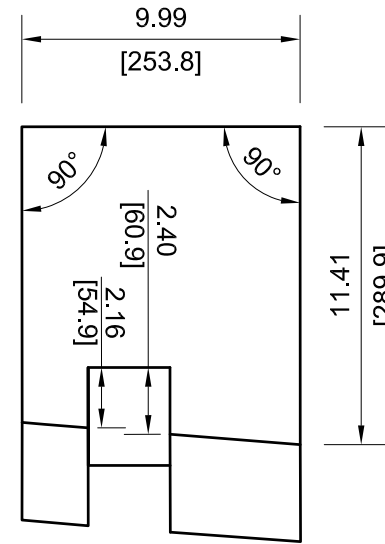

NOTE: ALL VIEWS TAKEN AS TRUE VIEWS PARALLEL TO SURFACE OF PART

		DRAWING NUMBER			
		AES-D0002			
SIZE	SCALE	SHEET	OF	REVISION	
A3	NONE	49	167	F	

-163

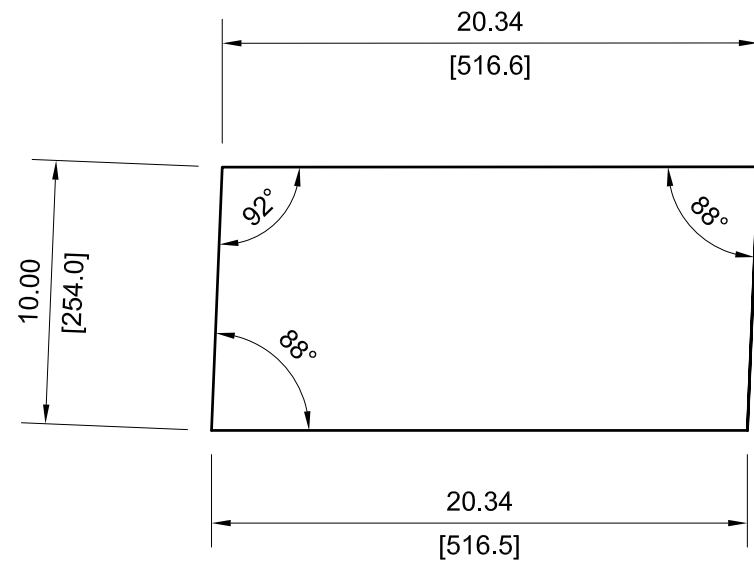

VIEW D6-50

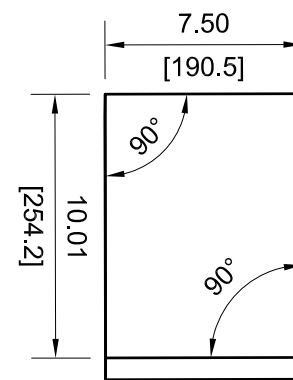

VIEW D7-50

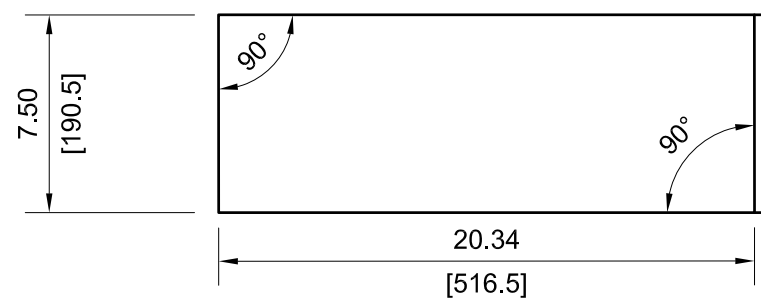

VIEW E5-50

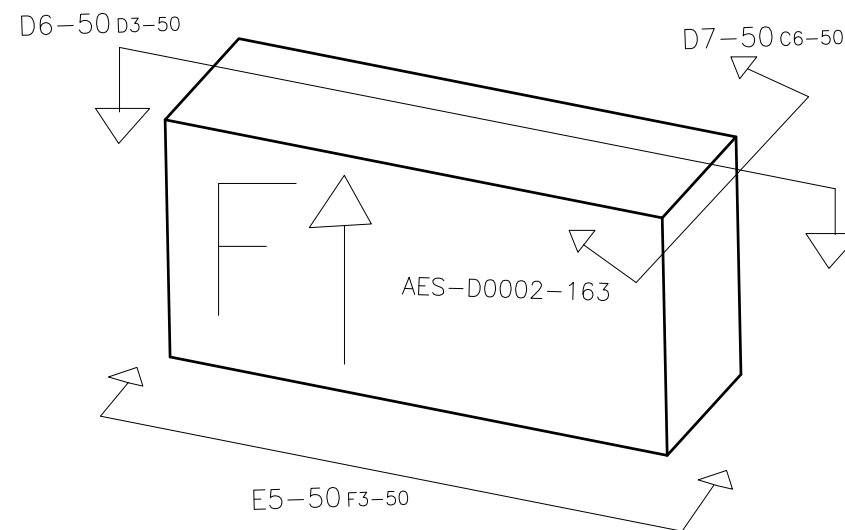
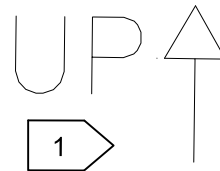

NOTE: ALL VIEWS TAKEN AS TRUE VIEWS PARALLEL TO SURFACE OF PART



DRAWING NUMBER				
AES-D0002				
SIZE	SCALE	SHEET	OF	REVISION
A3	NONE	50	167	F

-165

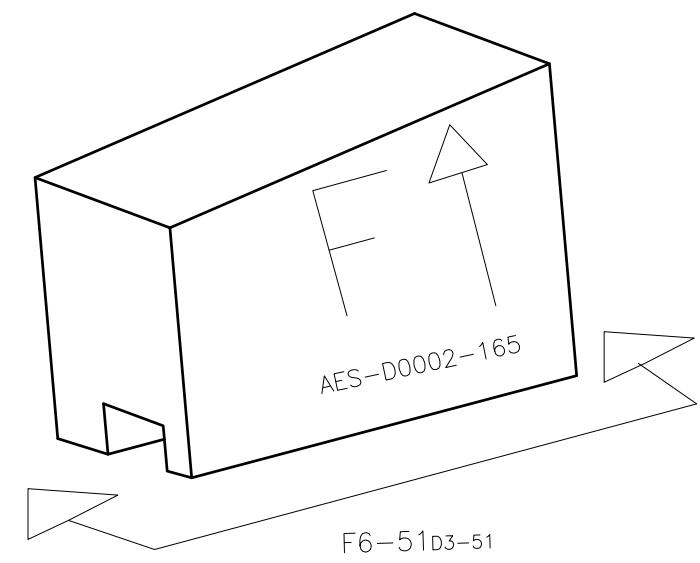
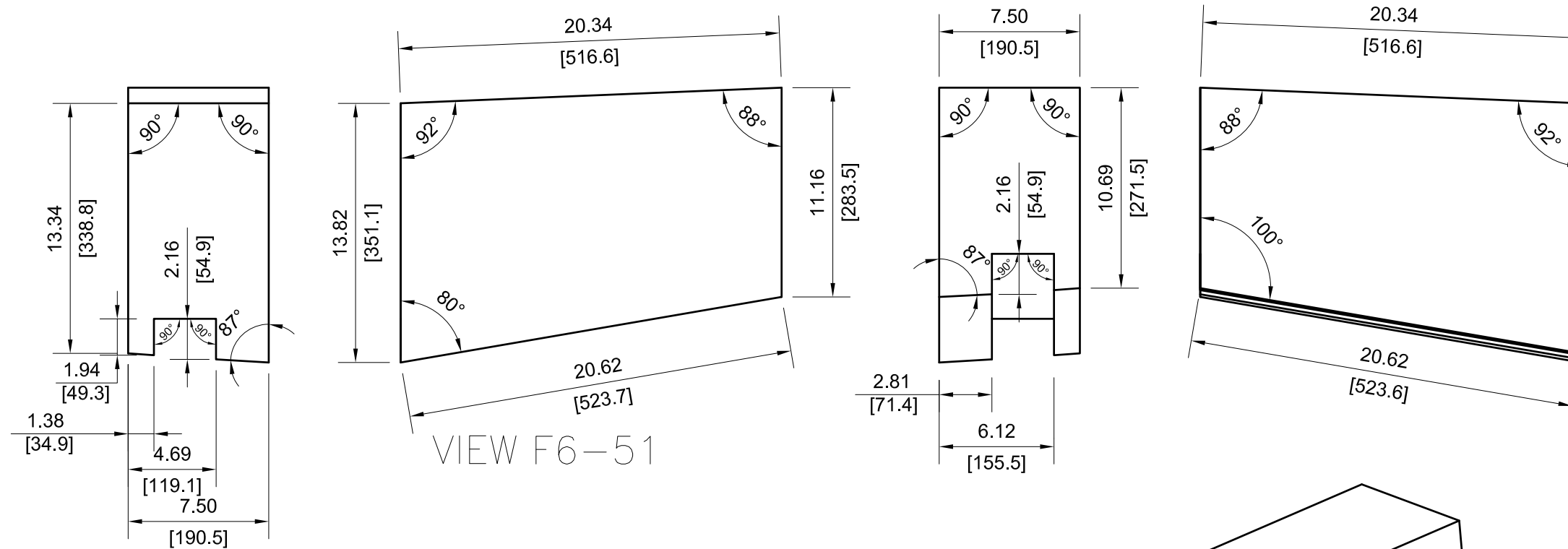

NOTE: ALL VIEWS TAKEN AS TRUE VIEWS PARALLEL TO SURFACE OF PART

	DRAWING NUMBER				AES-D0002
	SIZE	SCALE	SHEET	OF	REVISION
A3	NONE	51	167	F	

- 167

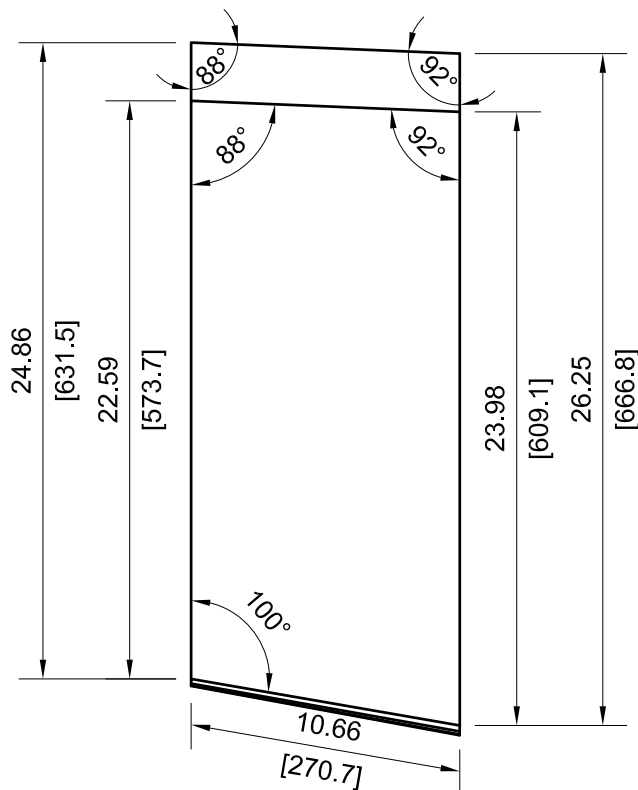
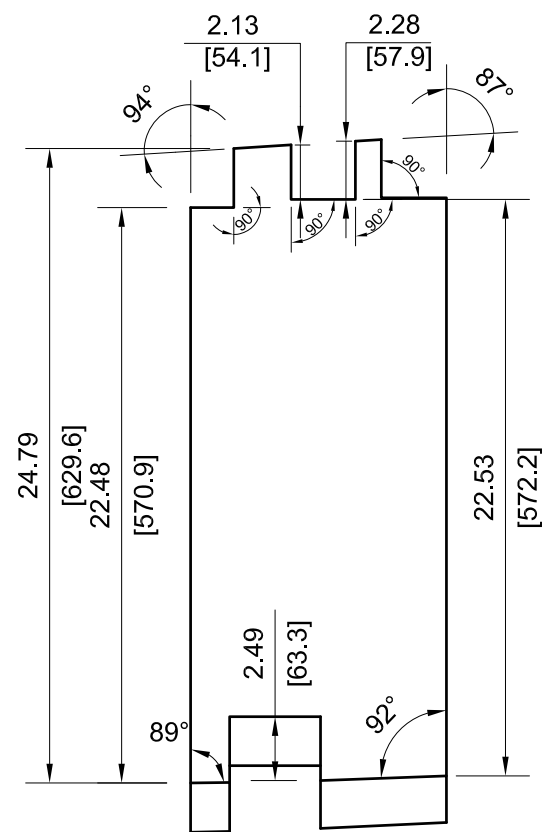

VIEW F7-52

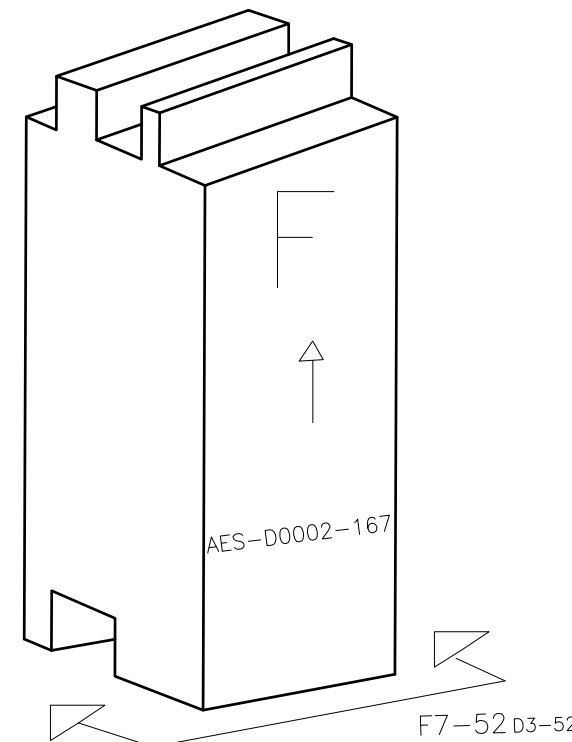
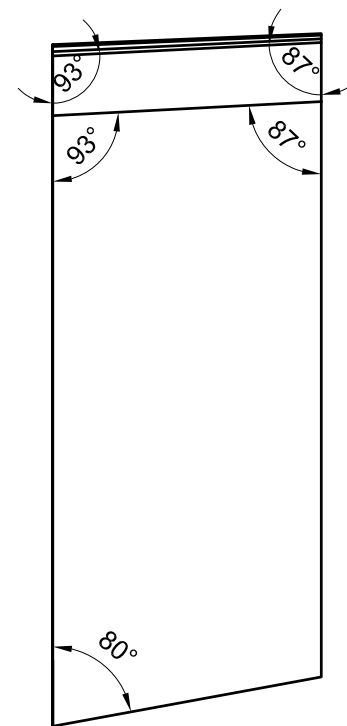
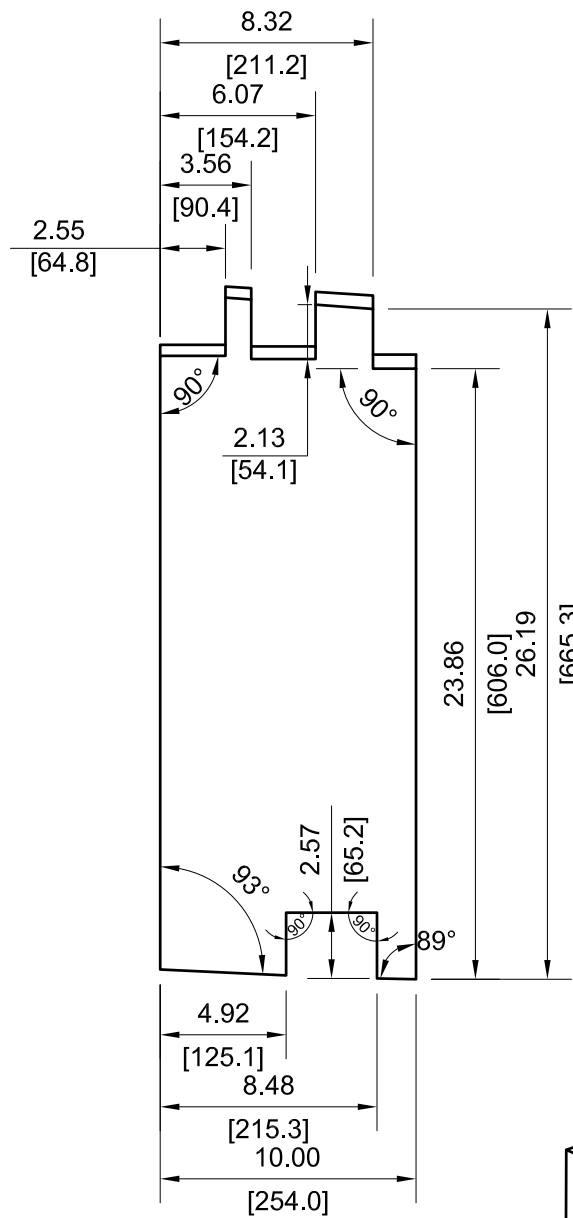

F7-52 D3-52

NOTE: ALL VIEWS TAKEN AS TRUE VIEWS PARALLEL TO SURFACE OF PART

		DRAWING NUMBER			
		AES-D0002			
SIZE	SCALE	SHEET	OF	REVISION	
A3	NONE	52	167	F	

- 169

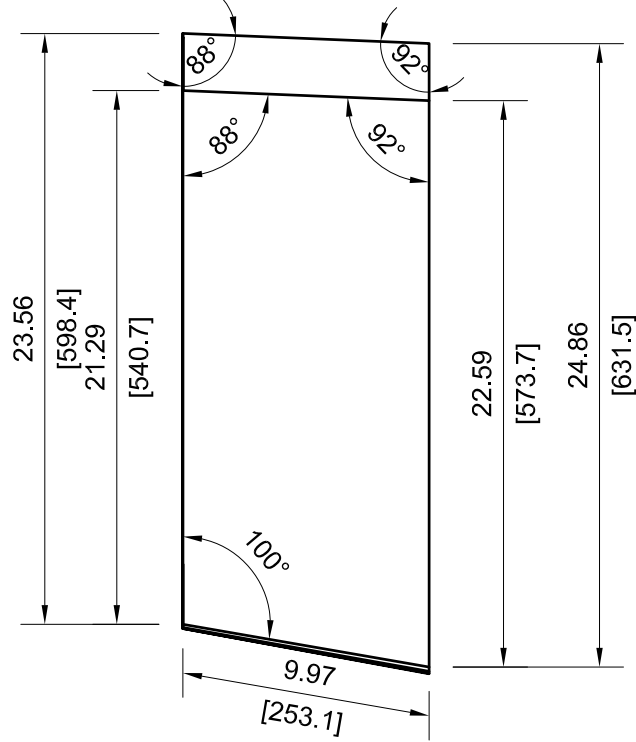
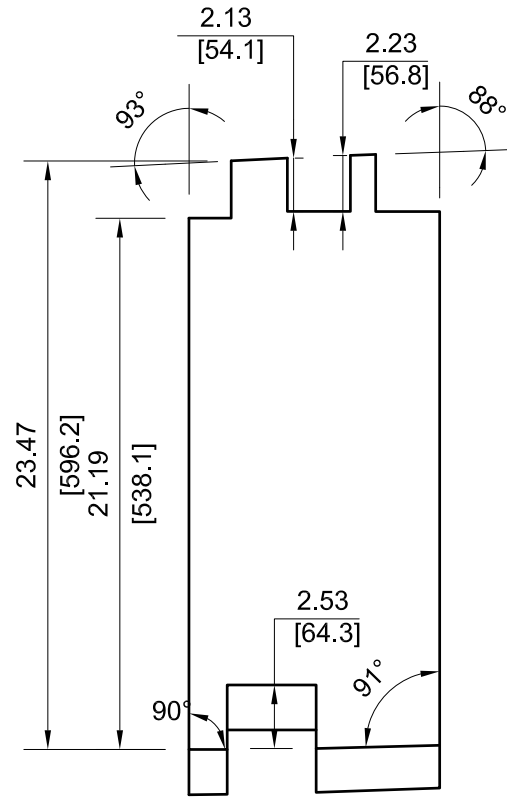

VIEW F7-53

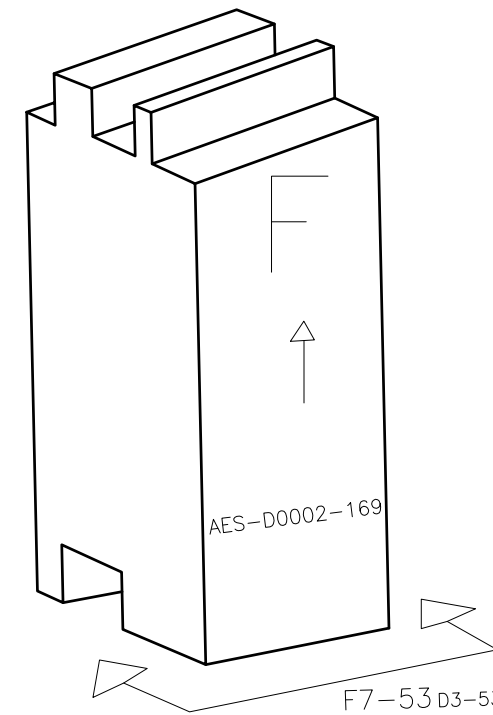
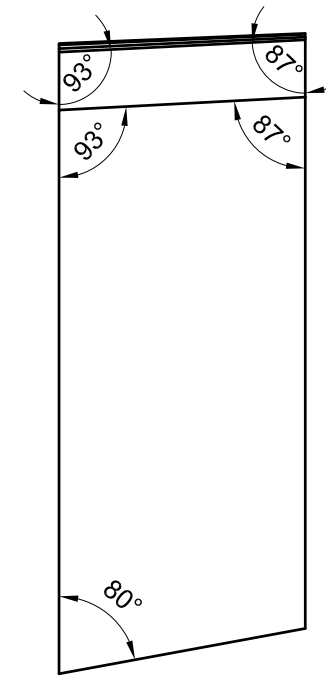
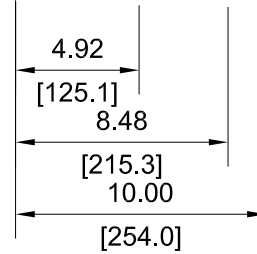
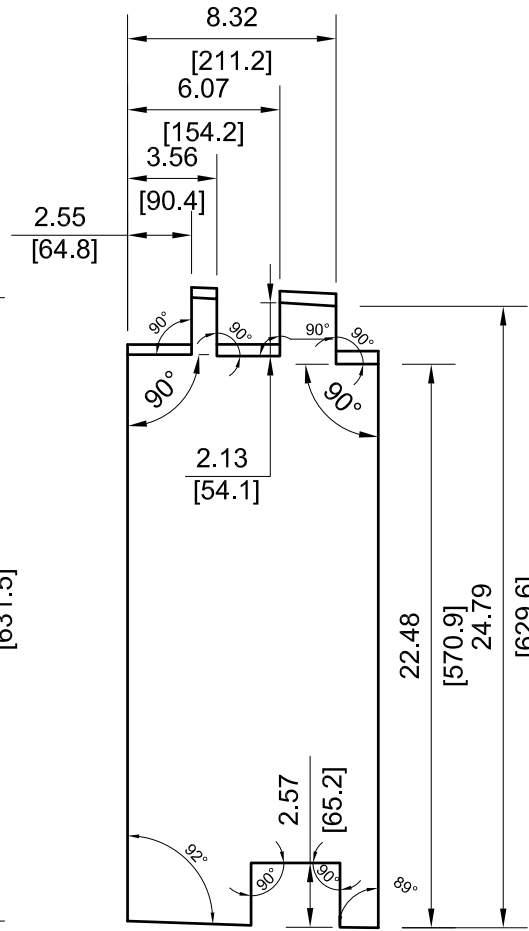

NOTE: ALL VIEWS TAKEN AS TRUE VIEWS PARALLEL TO SURFACE OF PART

		DRAWING NUMBER			
		AES-D0002			
SIZE	SCALE	SHEET	OF	REVISION	
A3	NONE	53	167	F	

- 171

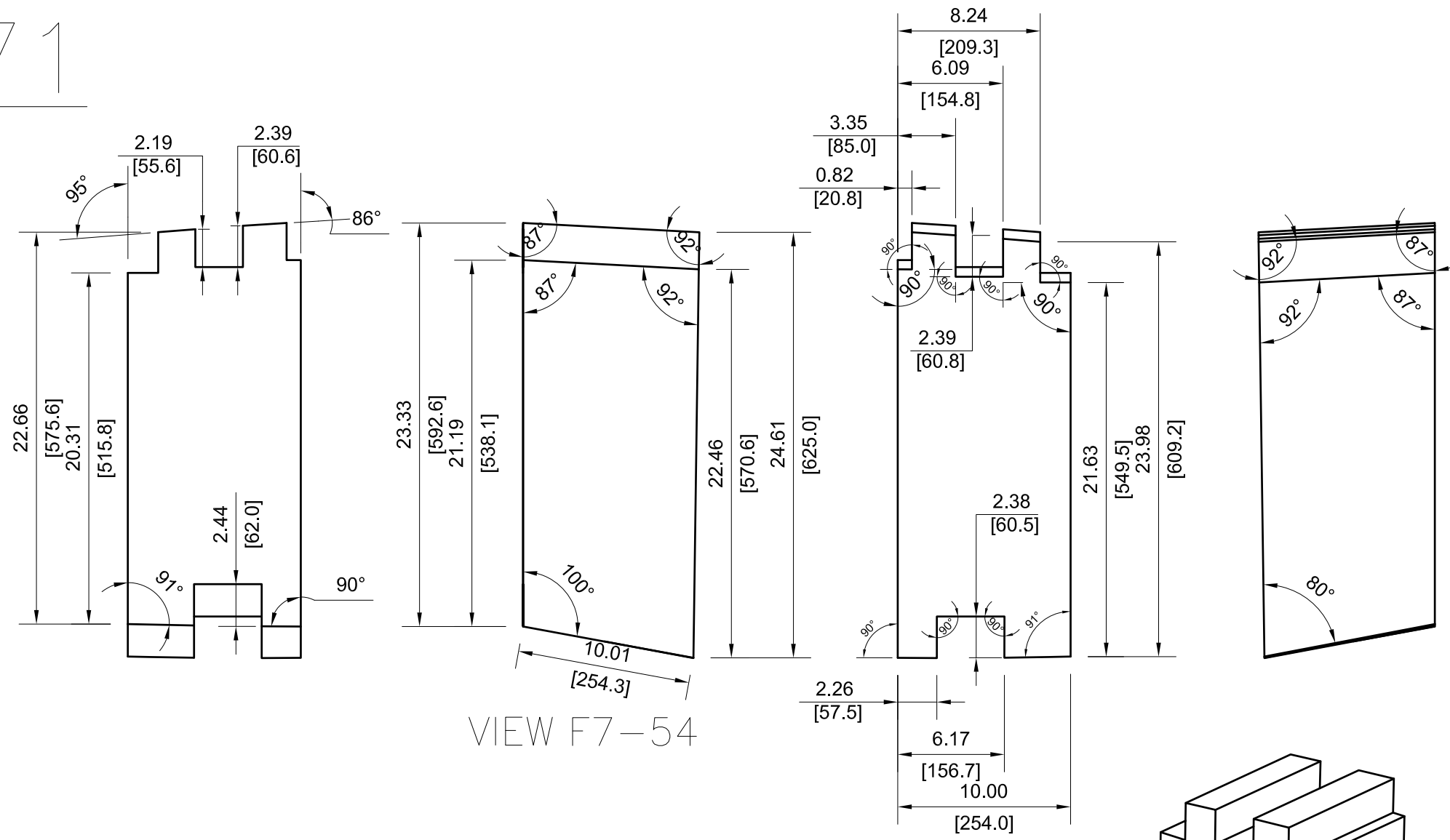

VIEW F7-54

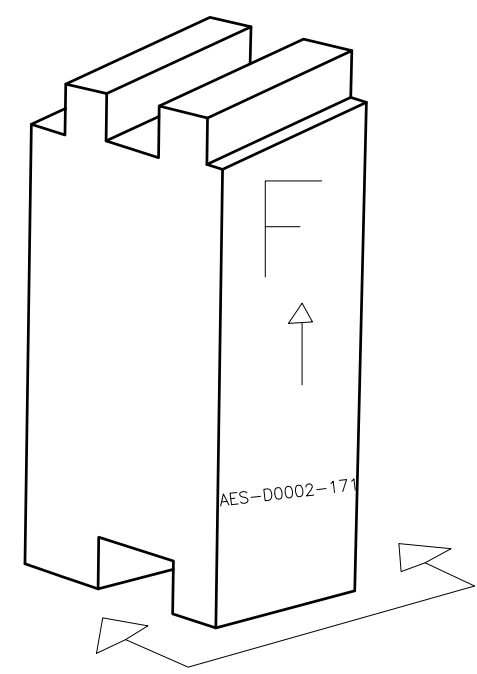

F7-54 D3-54

NOTE: ALL VIEWS TAKEN AS TRUE VIEWS PARALLEL TO SURFACE OF PART

		DRAWING NUMBER			
		AES-D0002			
SIZE	SCALE	SHEET	OF	REVISION	
A3	NONE	54	167	F	

-173

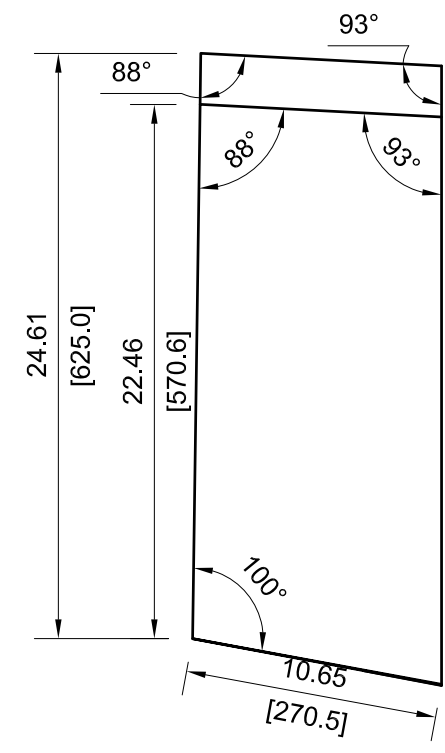
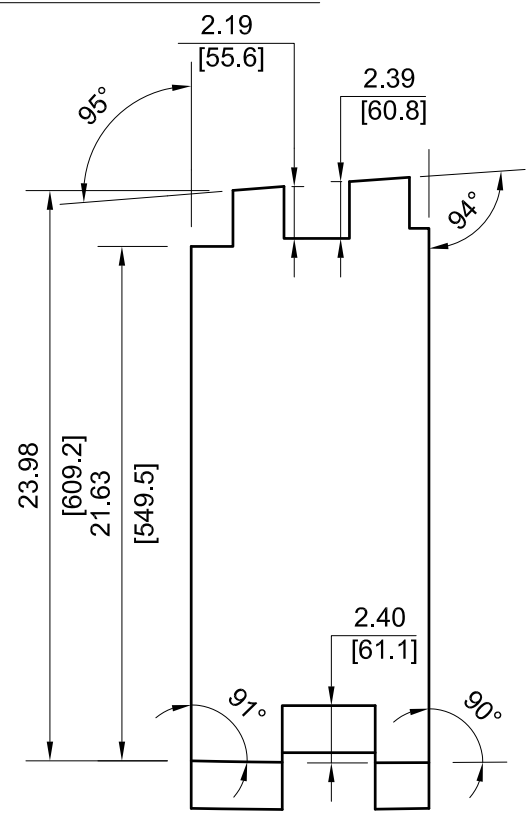

VIEW F7-55

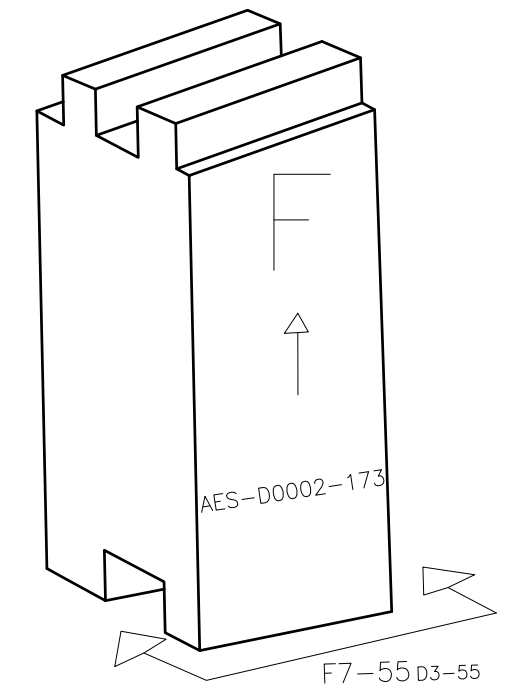
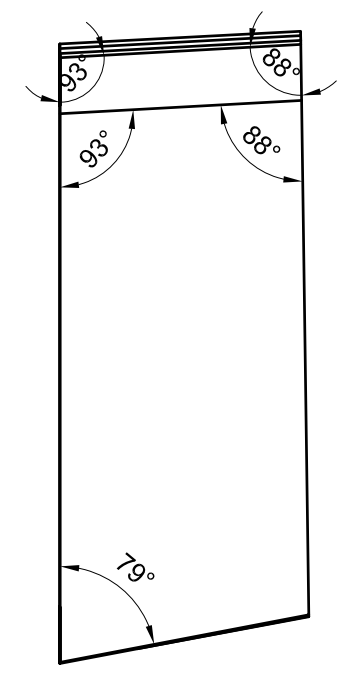
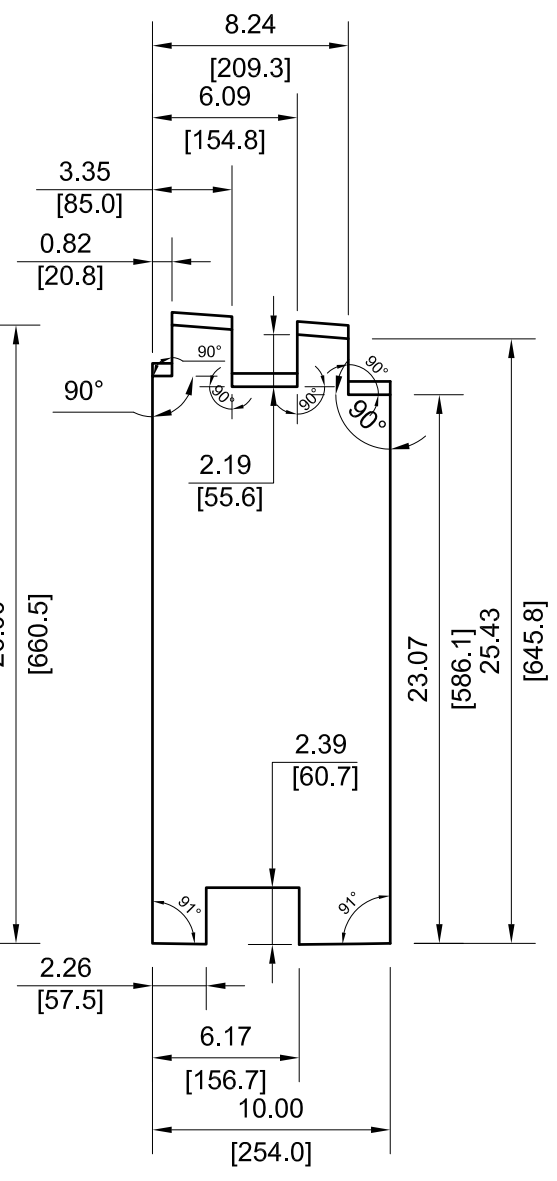

NOTE: ALL VIEWS TAKEN AS TRUE VIEWS PARALLEL TO SURFACE OF PART

		DRAWING NUMBER			
		AES-D0002			
SIZE	SCALE	SHEET	OF	REVISION	
A3	NONE	55	167	F	

-175

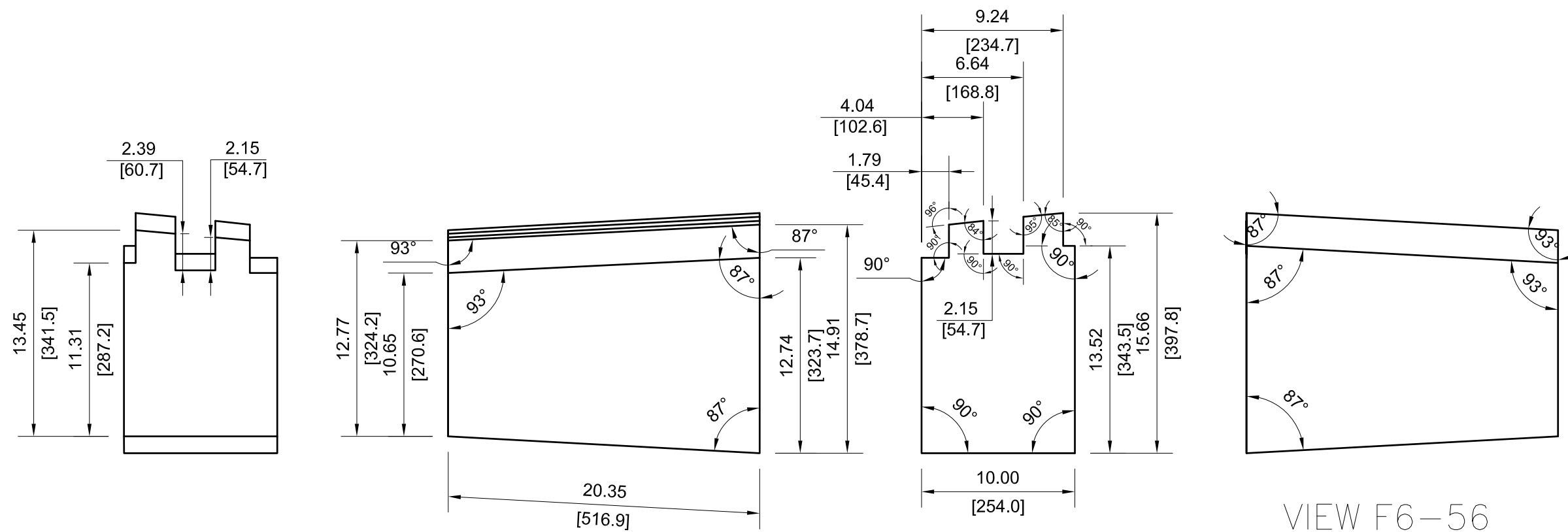

VIEW F6-56

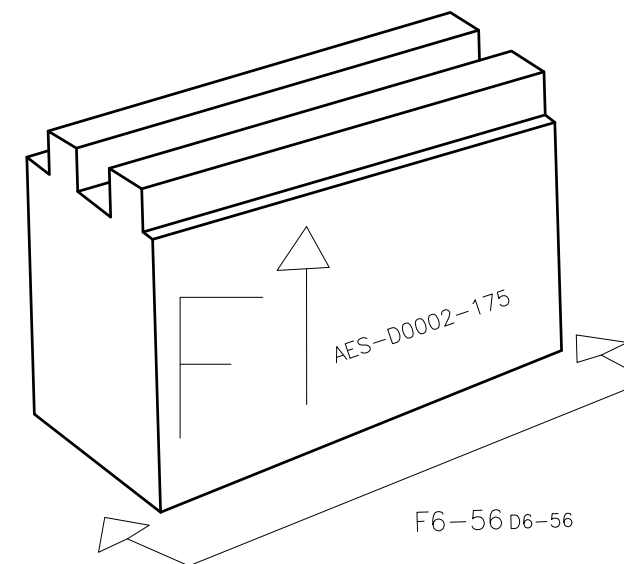

NOTE: ALL VIEWS TAKEN AS TRUE VIEWS PARALLEL TO SURFACE OF PART

		DRAWING NUMBER			
		AES-D0002			
SIZE	SCALE	SHEET	OF	REVISION	
A3	NONE	56	167	F	

- 177

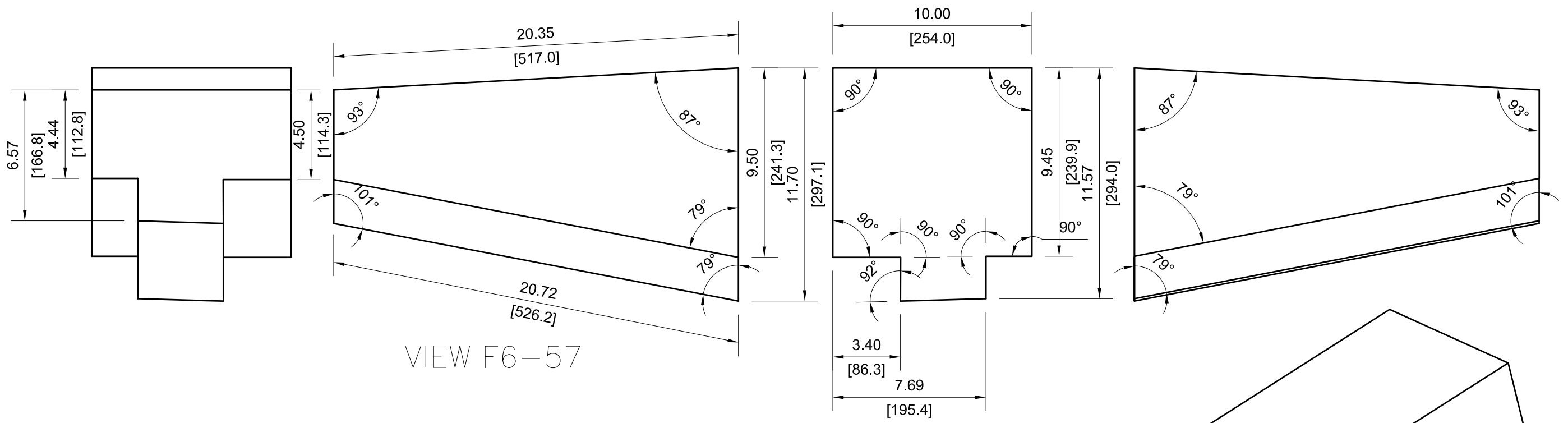

VIEW F6-57

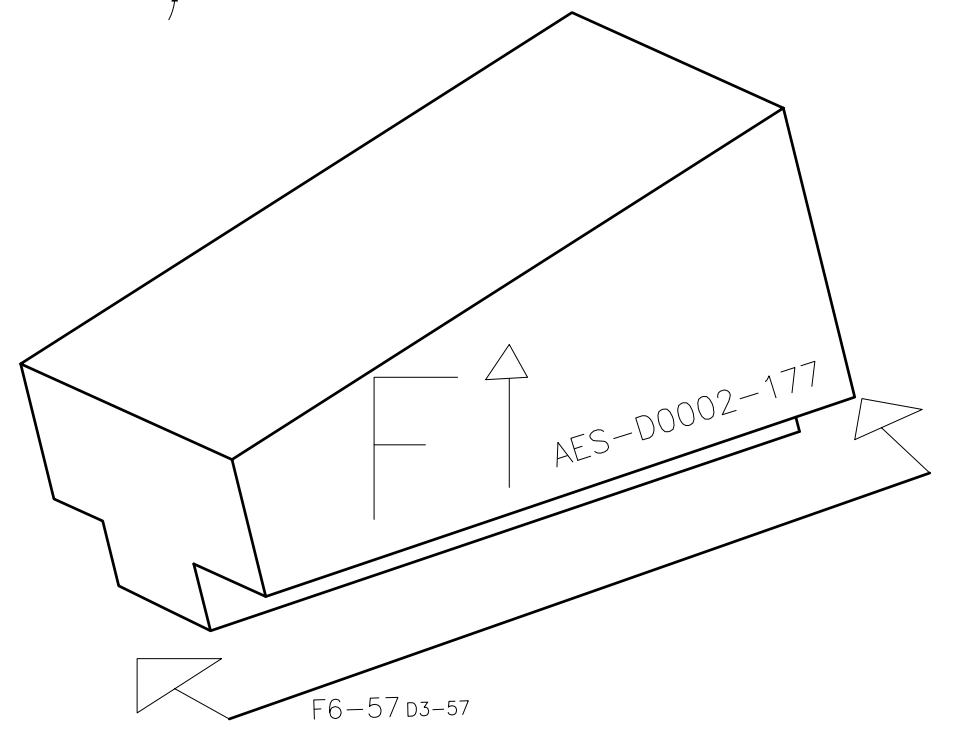

NOTE: ALL VIEWS TAKEN AS TRUE VIEWS PARALLEL TO SURFACE OF PART

	DRAWING NUMBER				AES-D0002
	SIZE	SCALE	SHEET	OF	REVISION
A3	NONE	57	167	F	

-179

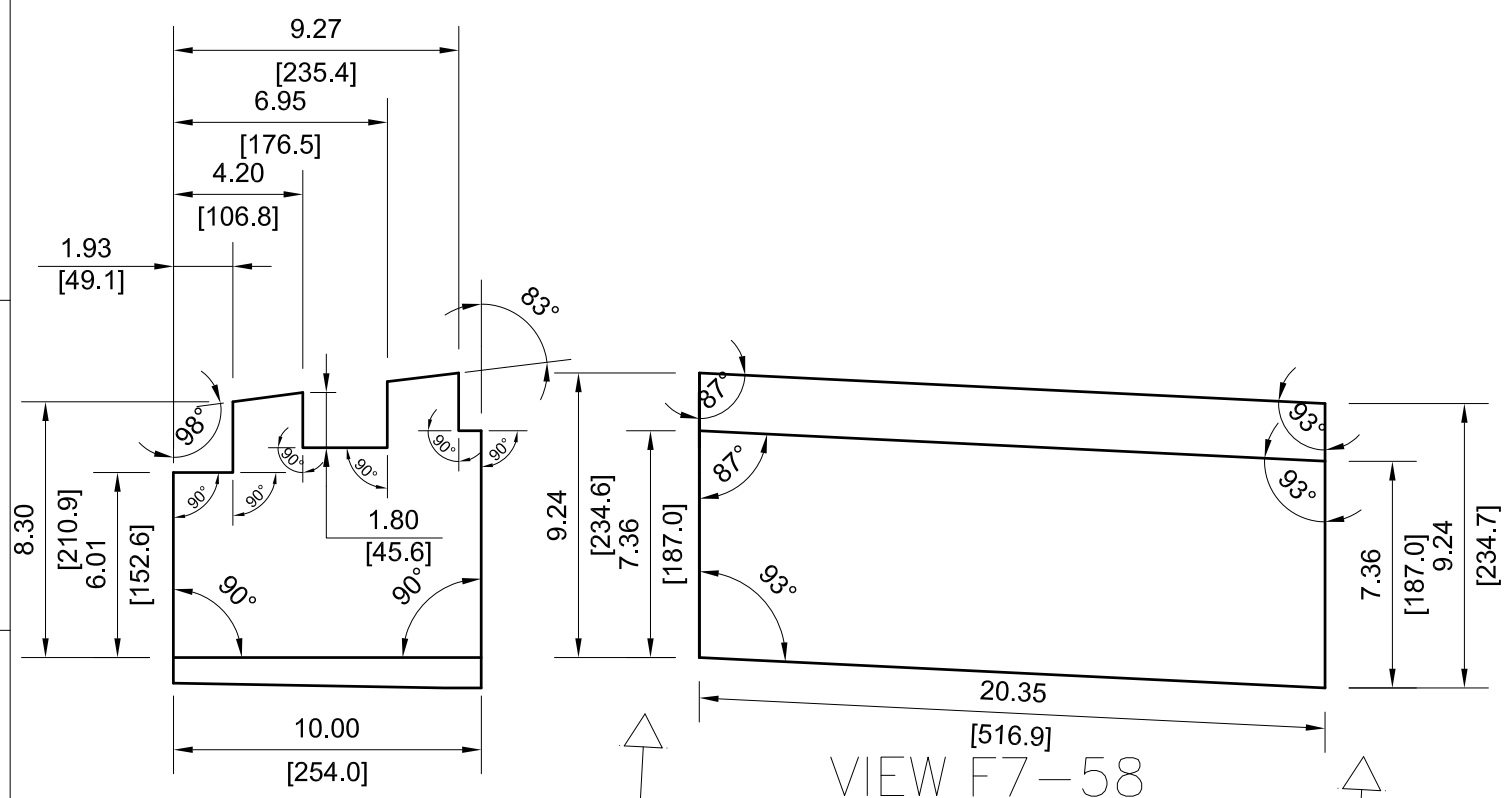

VIEW F7-58

D3-58 F3-58

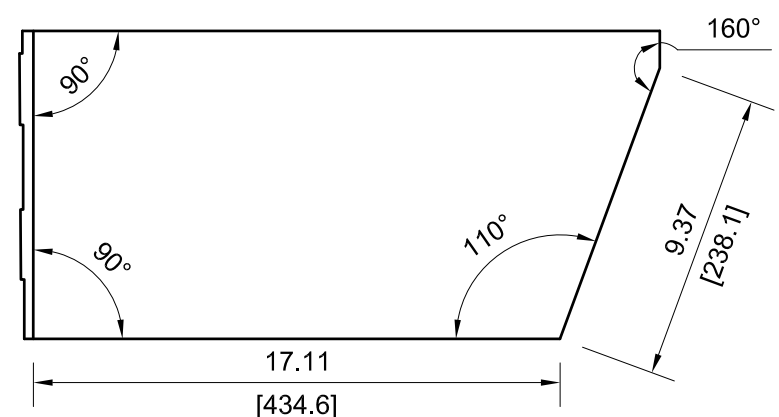

VIEW D3-58

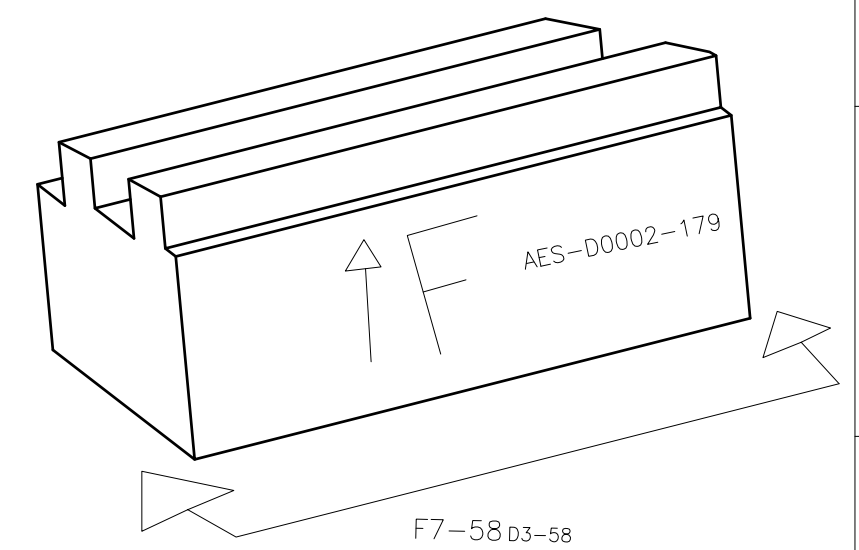
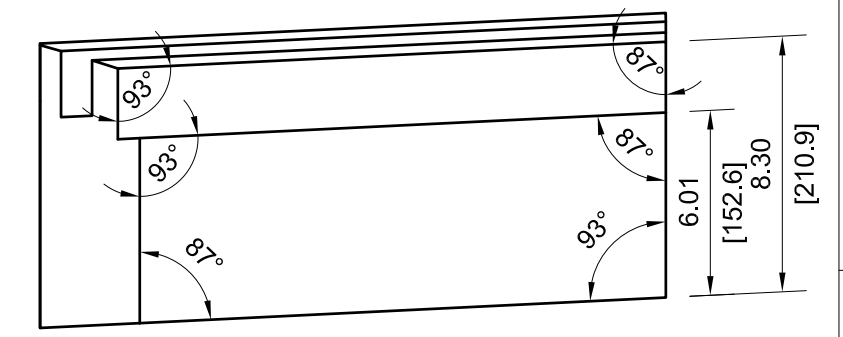
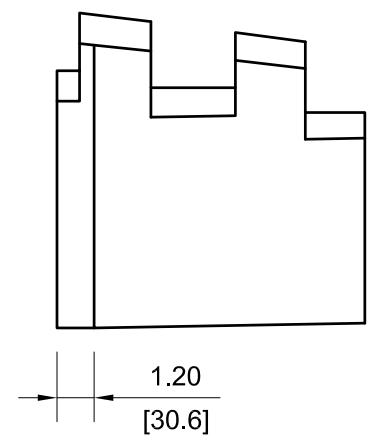

F7-58 D3-58

NOTE: ALL VIEWS TAKEN AS TRUE VIEWS PARALLEL TO SURFACE OF PART

		DRAWING NUMBER			
		AES-D0002			
SIZE	SCALE	SHEET	OF	REVISION	
A3	NONE	58	167	F	

-181

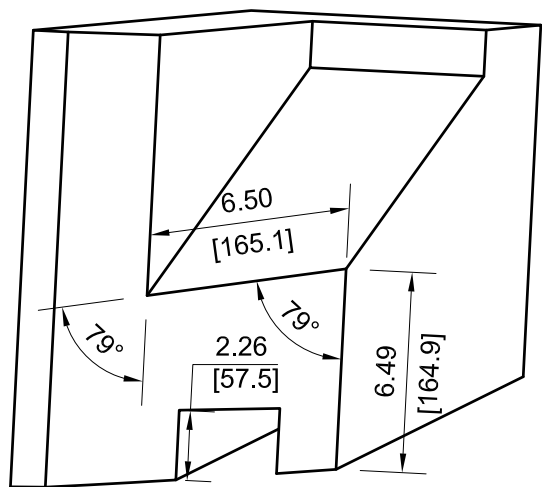

VIEW B6-59

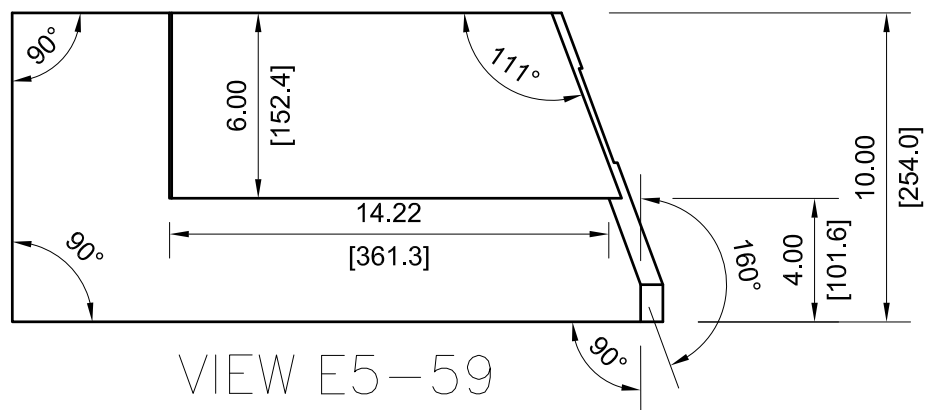

VIEW E5-59

B6-59c1-59

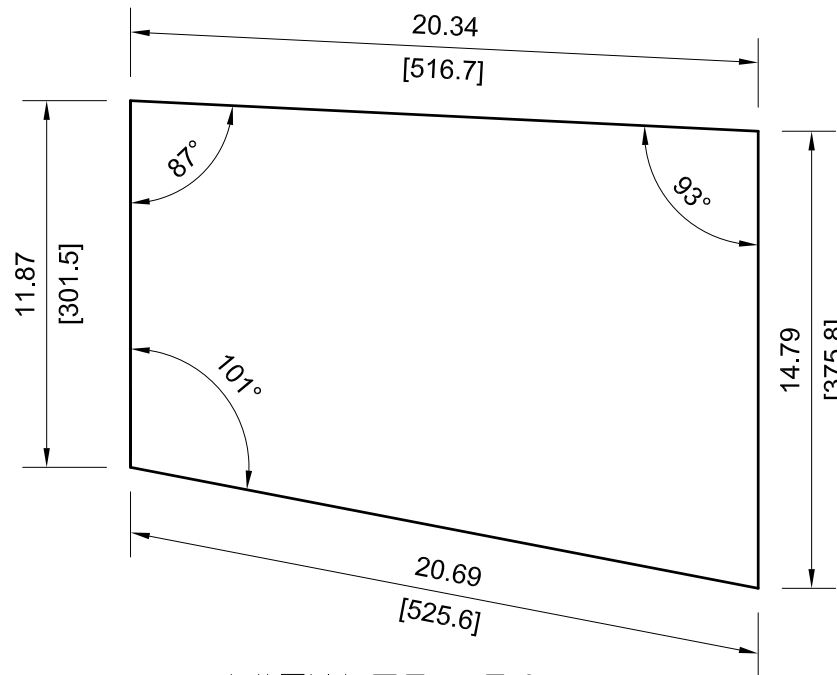
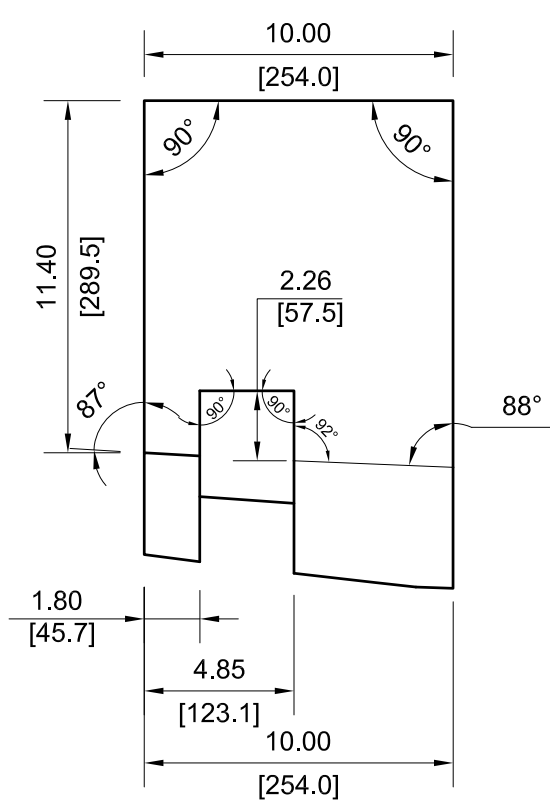

VIEW F5-59

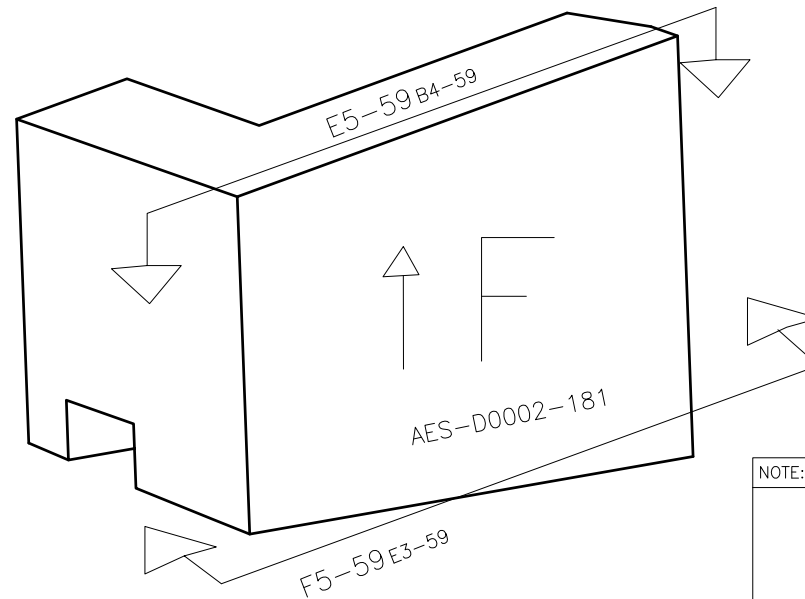
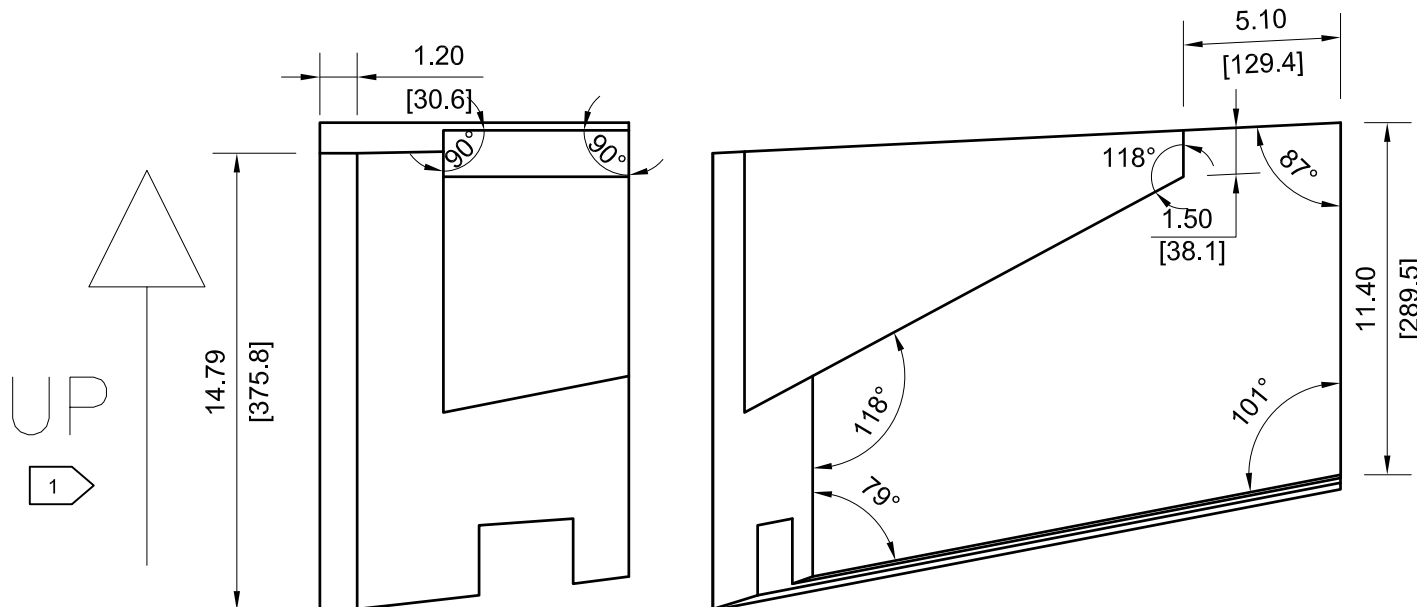

NOTE: ALL VIEWS TAKEN AS TRUE VIEWS PARALLEL TO SURFACE OF PART

		DRAWING NUMBER			
		AES-D0002			
SIZE	SCALE	SHEET	OF	REVISION	
A3	NONE	59	167	F	

-183

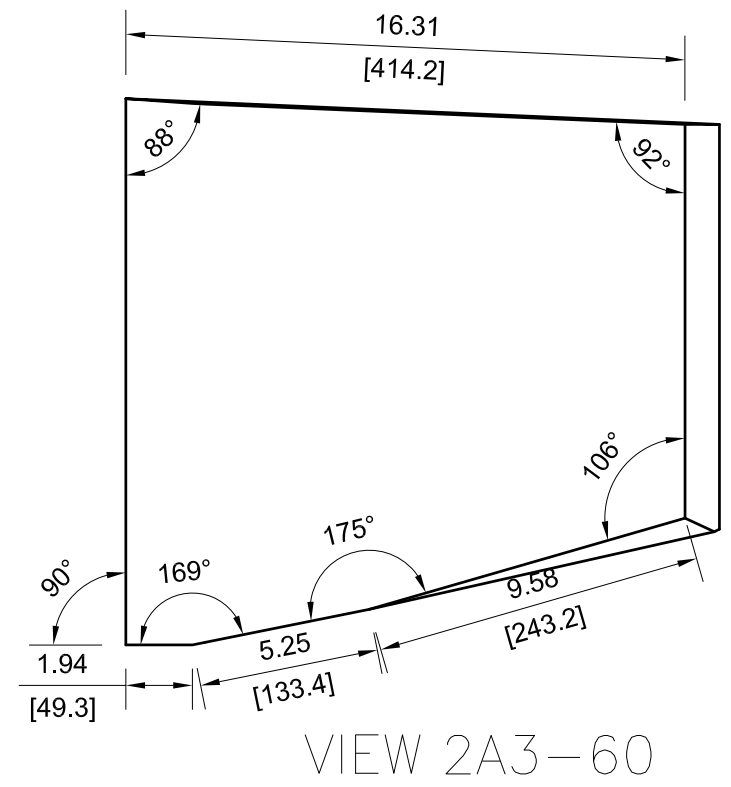
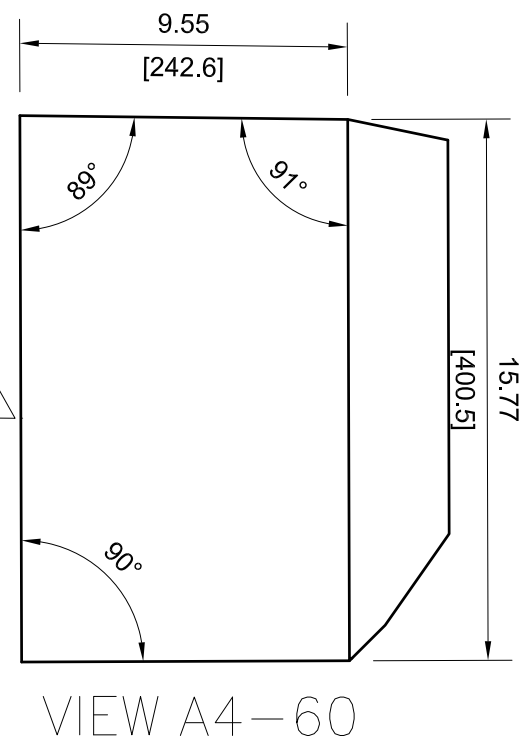
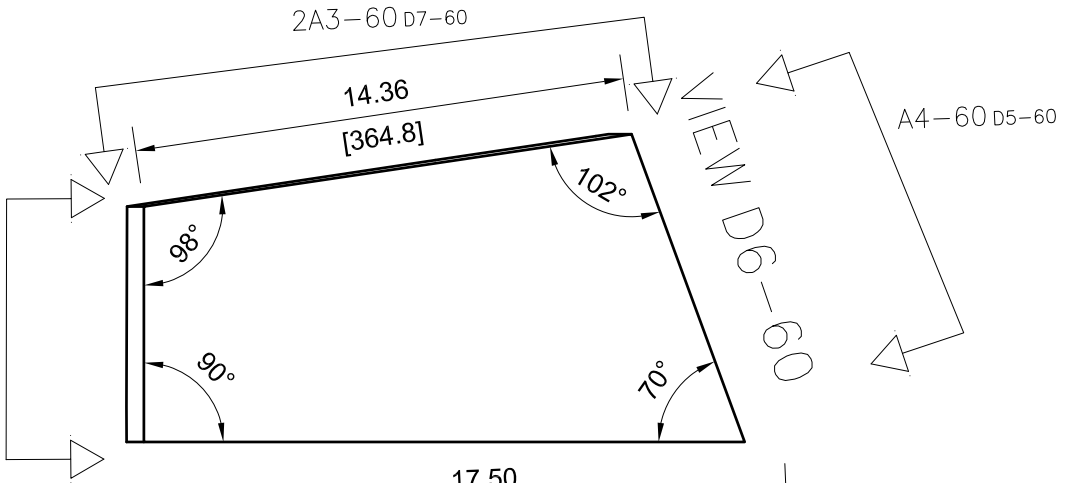
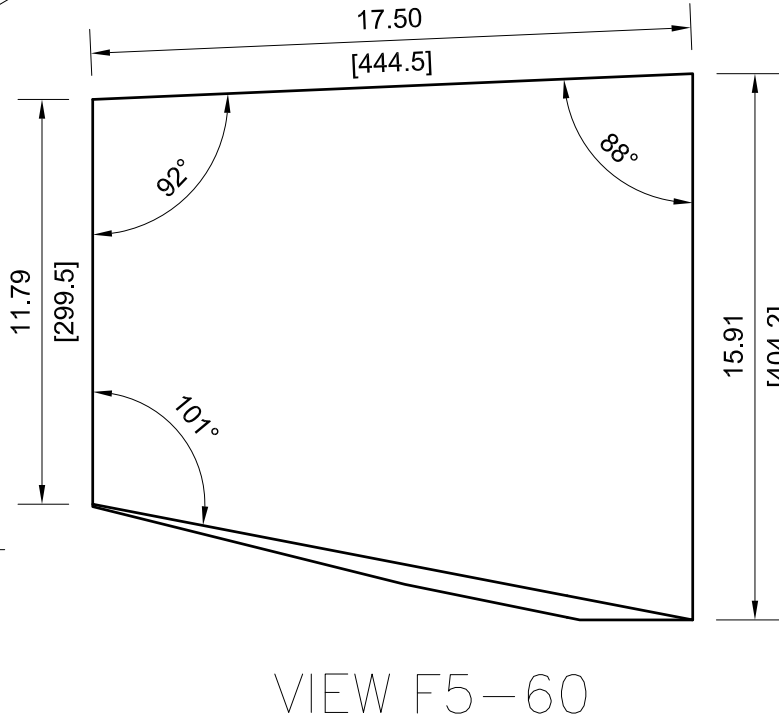
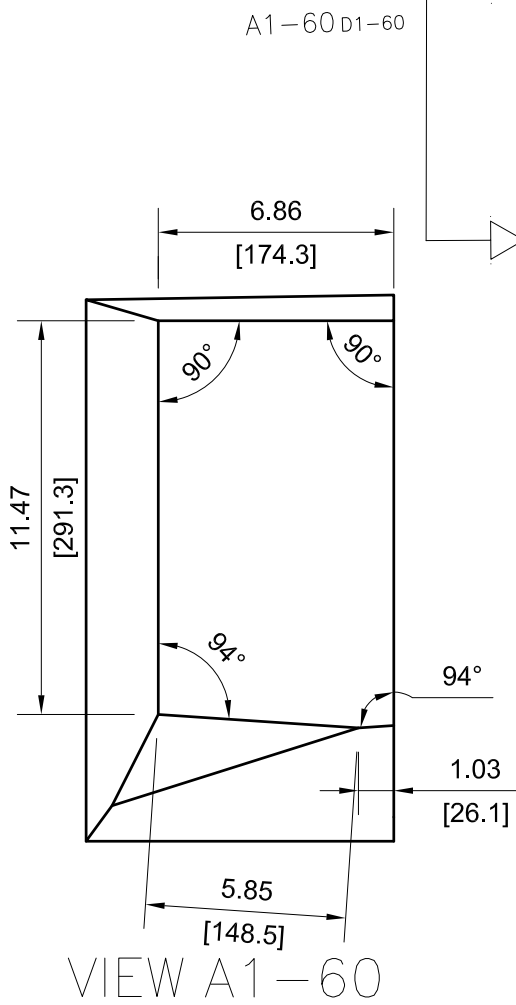

UP
1

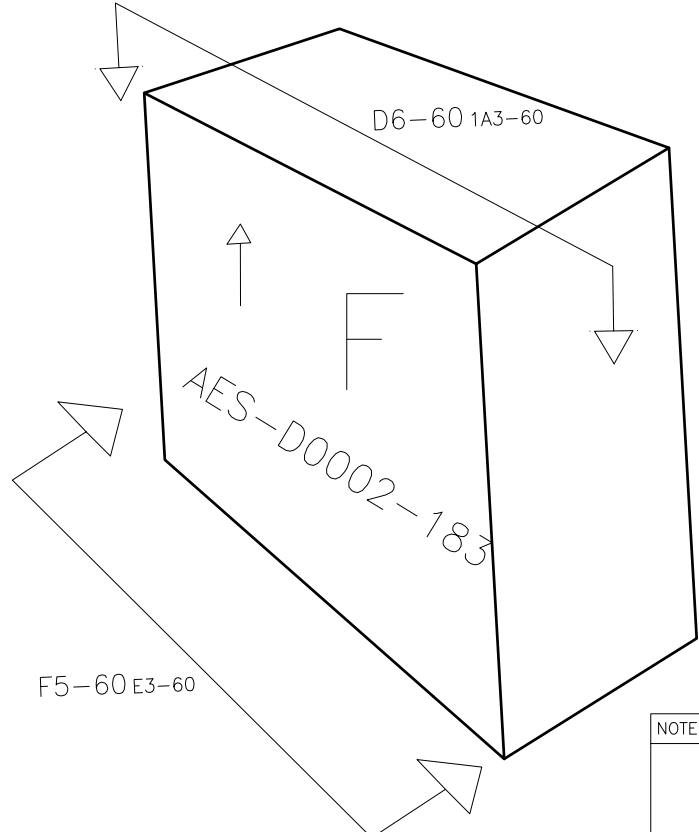

NOTE: ALL VIEWS TAKEN AS TRUE VIEWS PARALLEL TO SURFACE OF PART

		DRAWING NUMBER			
		AES-D0002			
SIZE	SCALE	SHEET	OF	REVISION	
A3	NONE	60	167	F	

-185

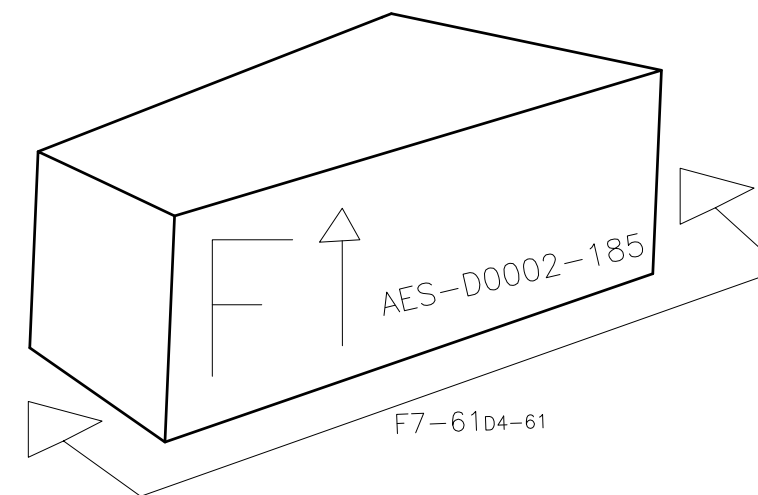
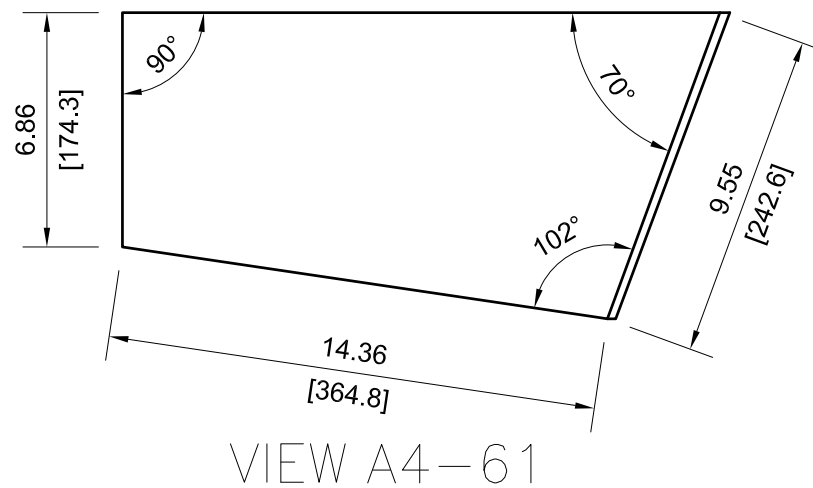
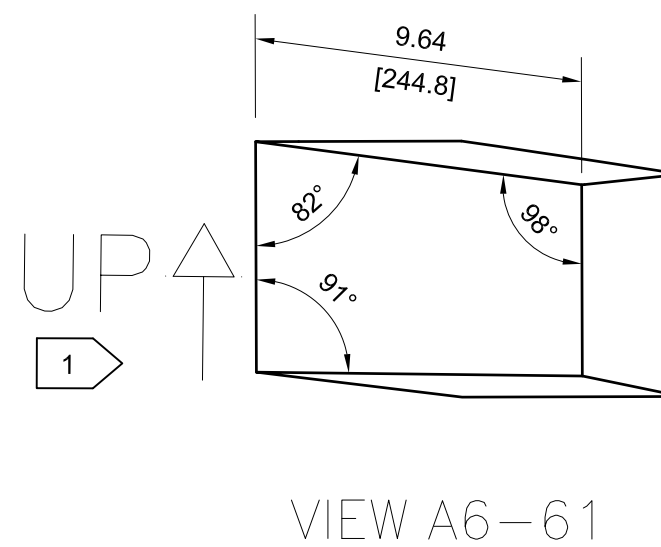
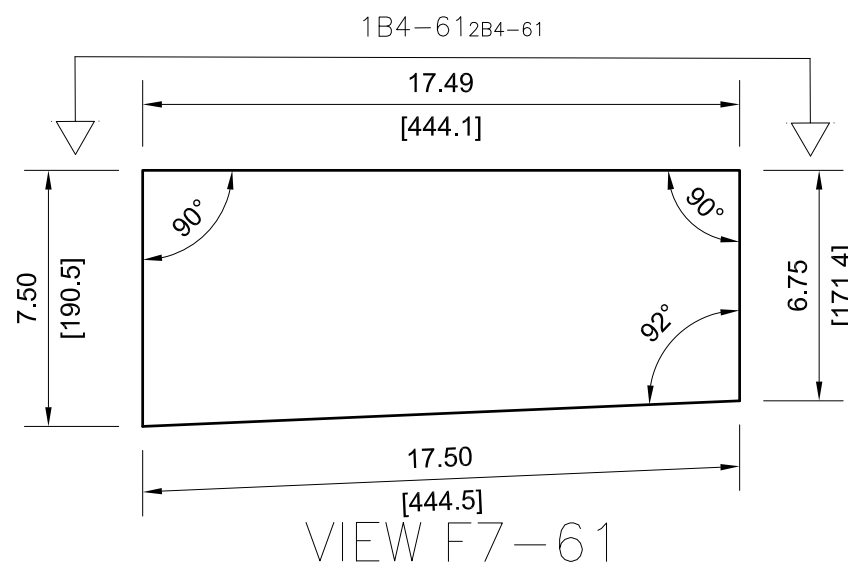
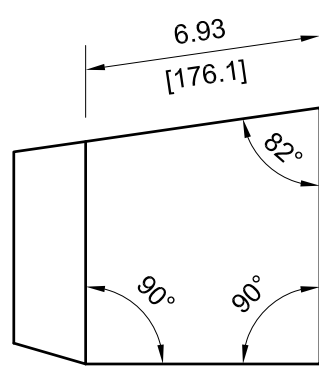
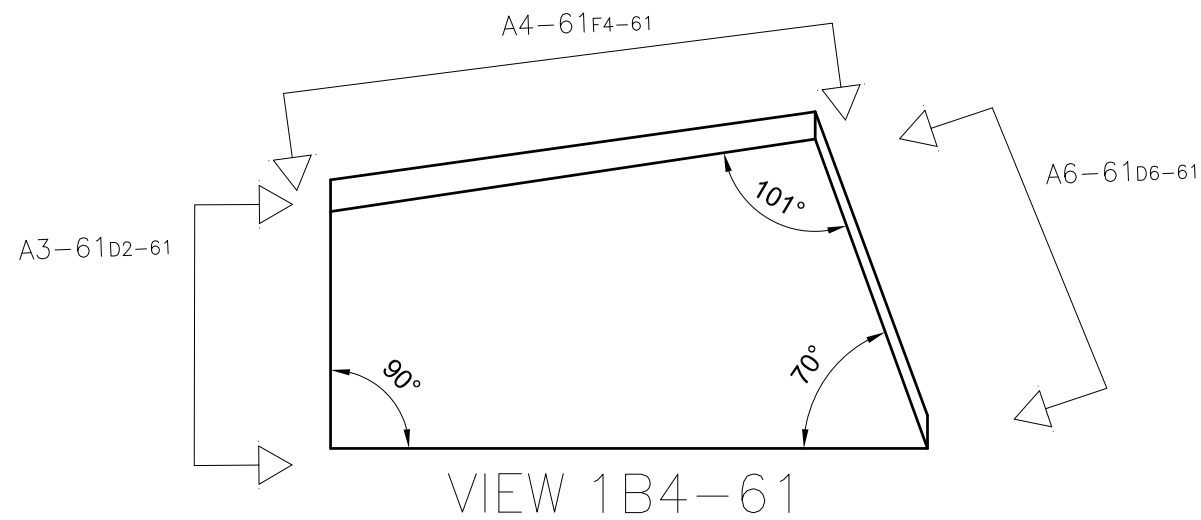

UP
1

NOTE: ALL VIEWS TAKEN AS TRUE VIEWS PARALLEL TO SURFACE OF PART

		DRAWING NUMBER			
		AES-D0002			
SIZE	SCALE	SHEET	OF	REVISION	
A3	NONE	61	167	F	

-187

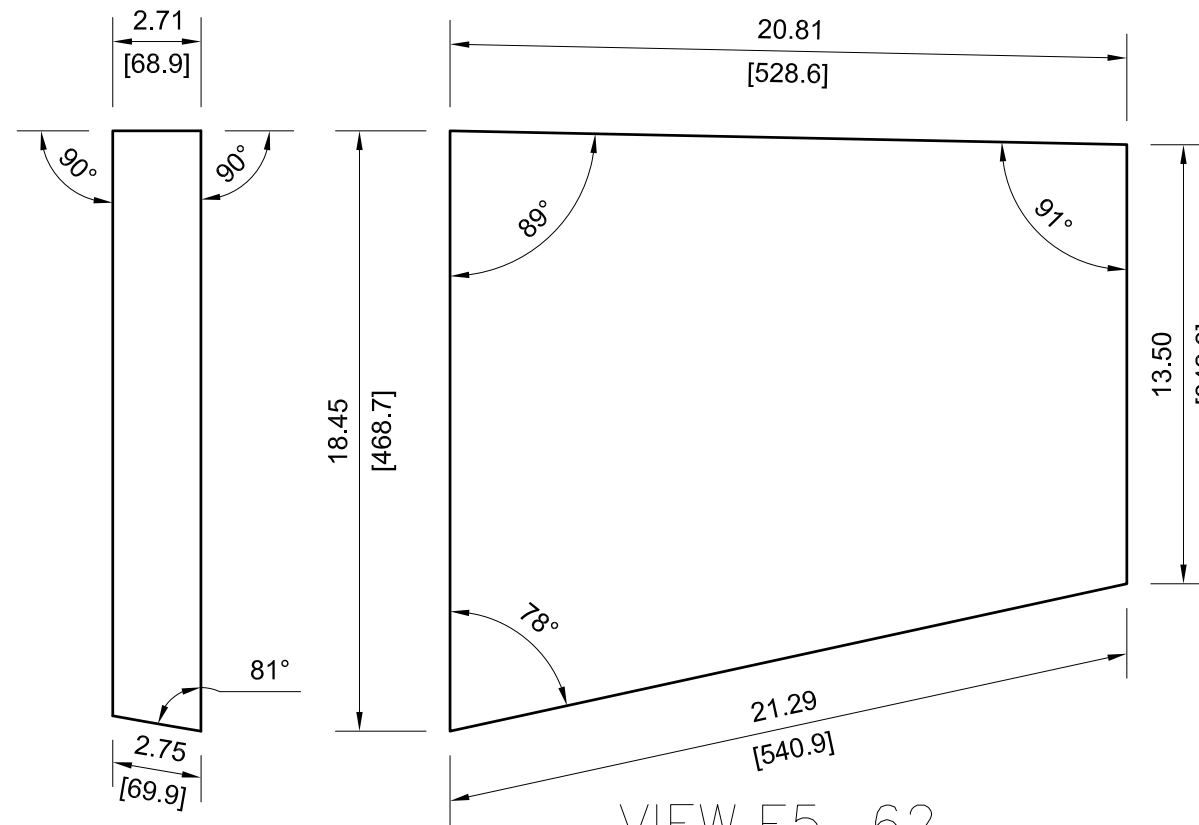

VIEW E5-62

UP ↑
1

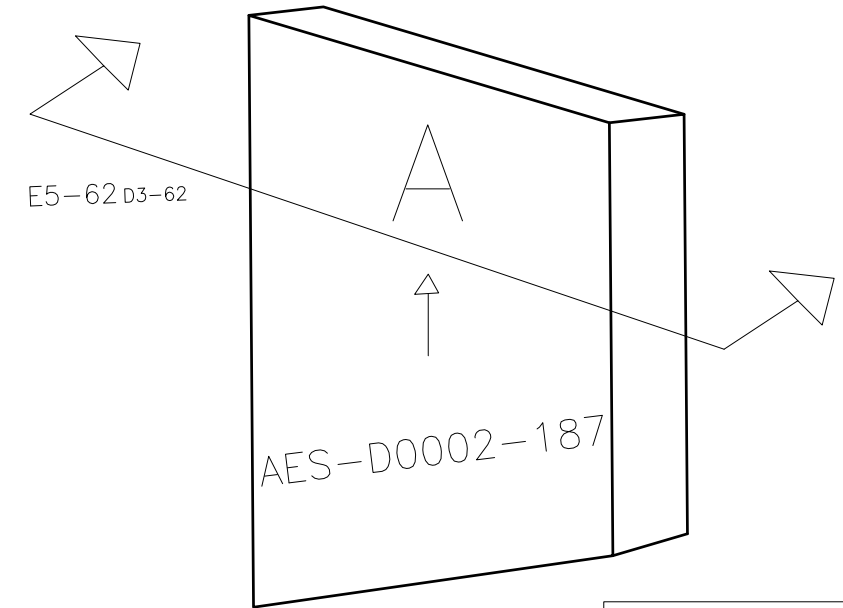
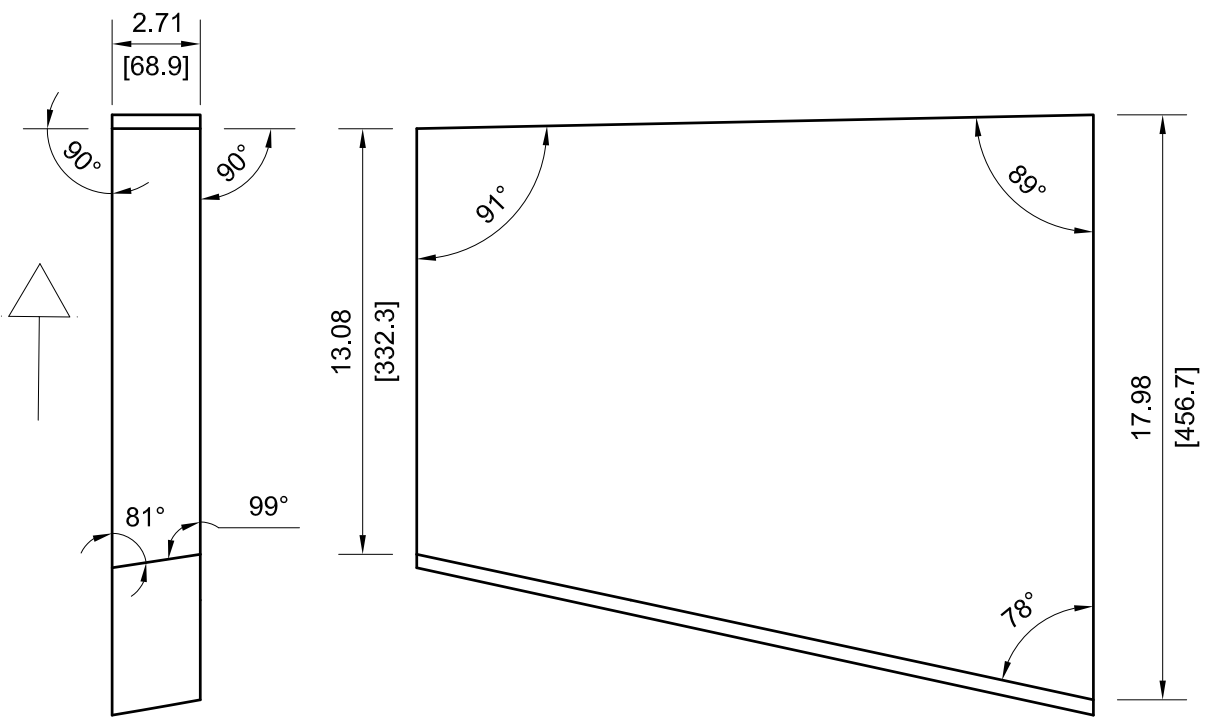

NOTE: ALL VIEWS TAKEN AS TRUE VIEWS PARALLEL TO SURFACE OF PART

		DRAWING NUMBER			AES-D0002	
SIZE	SCALE	SHEET	OF	REVISION		
A3	NONE	62	167	F		

-189

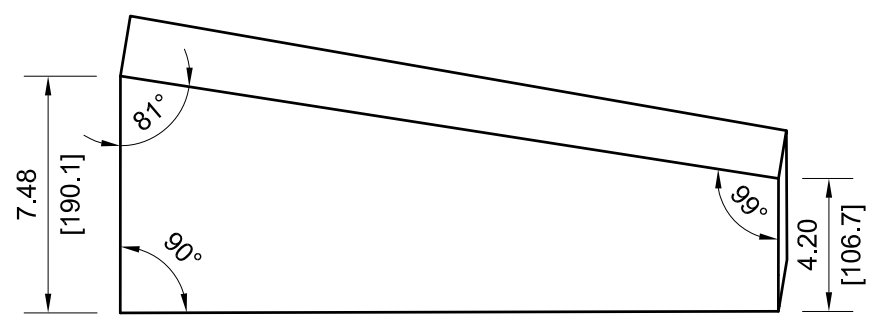

VIEW D7-63

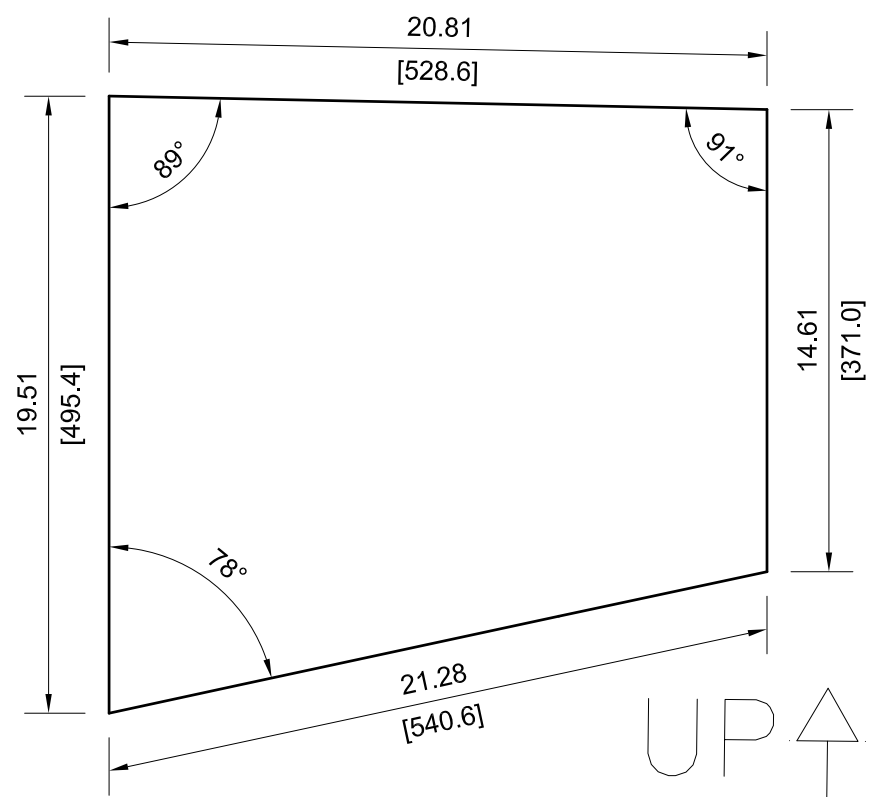
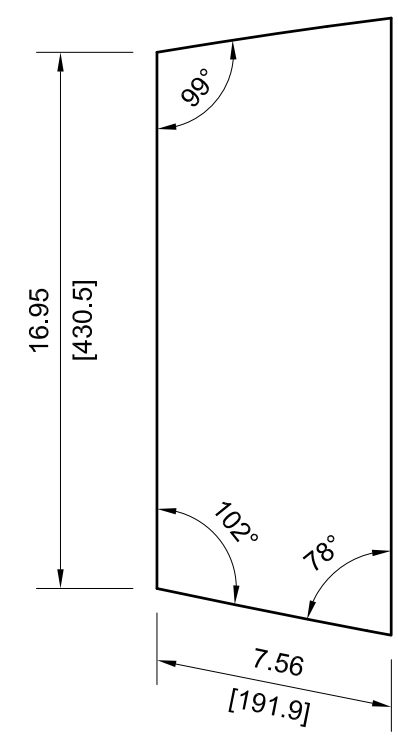

VIEW E6-63

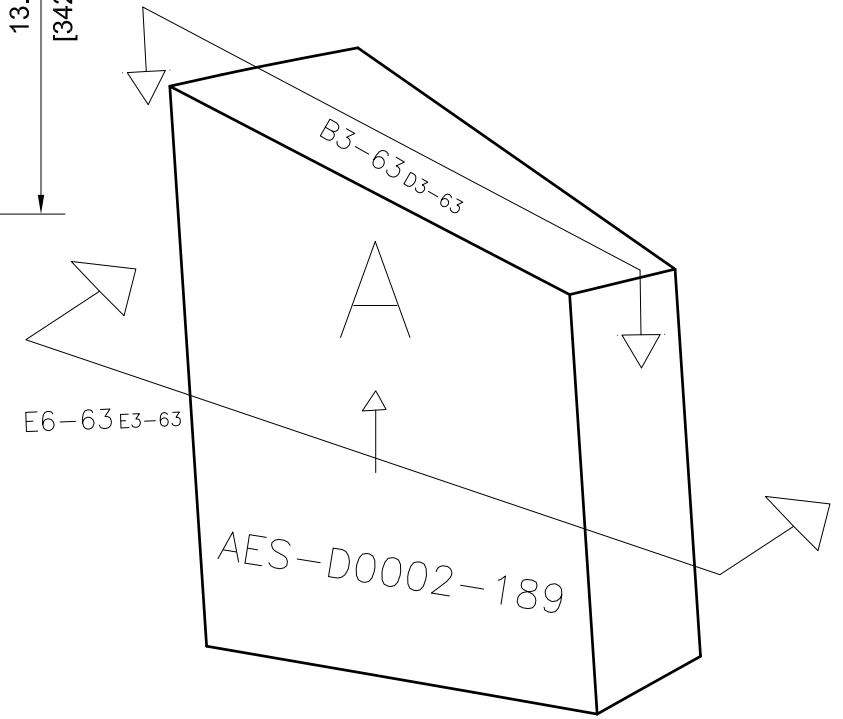
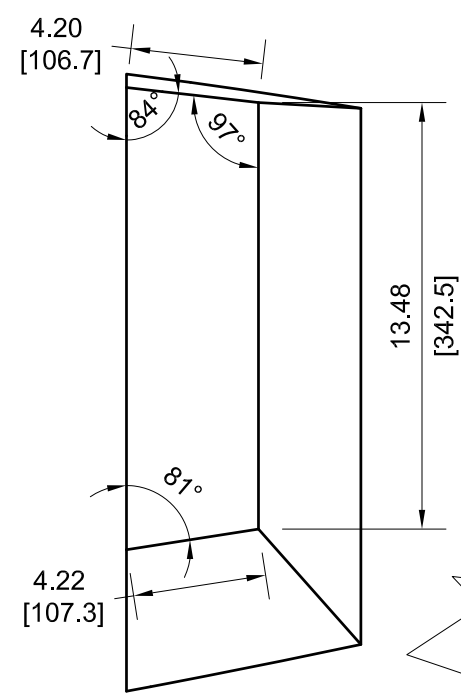

NOTE: ALL VIEWS TAKEN AS TRUE VIEWS PARALLEL TO SURFACE OF PART

	DRAWING NUMBER				AES-D0002
	SIZE	SCALE	SHEET	OF	REVISION
A3	NONE	63	167	F	

-191

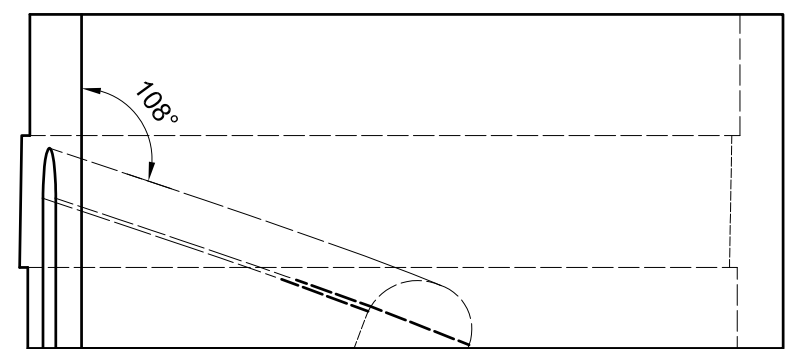

VIEW D8-64

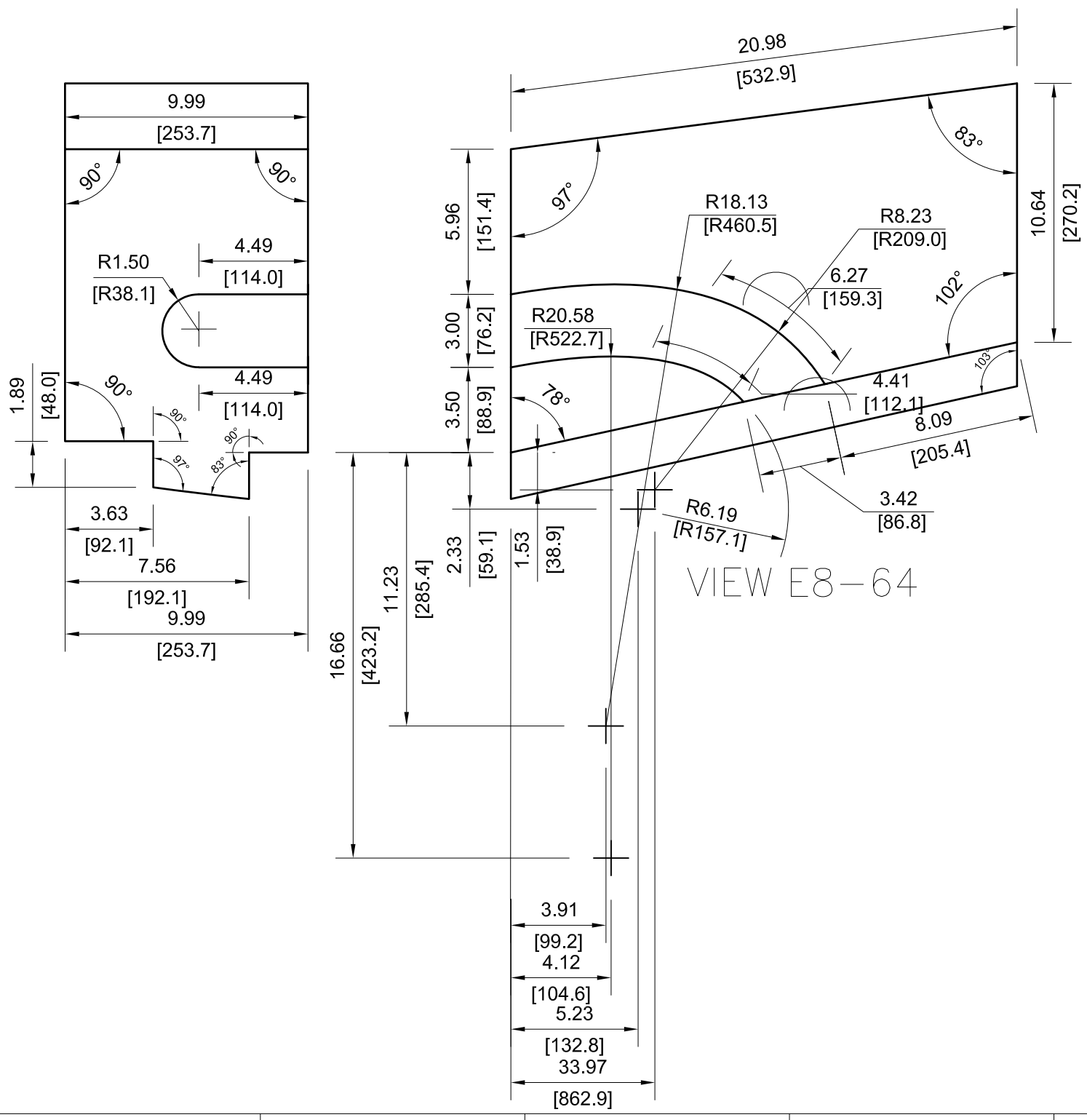

VIEW E8-64

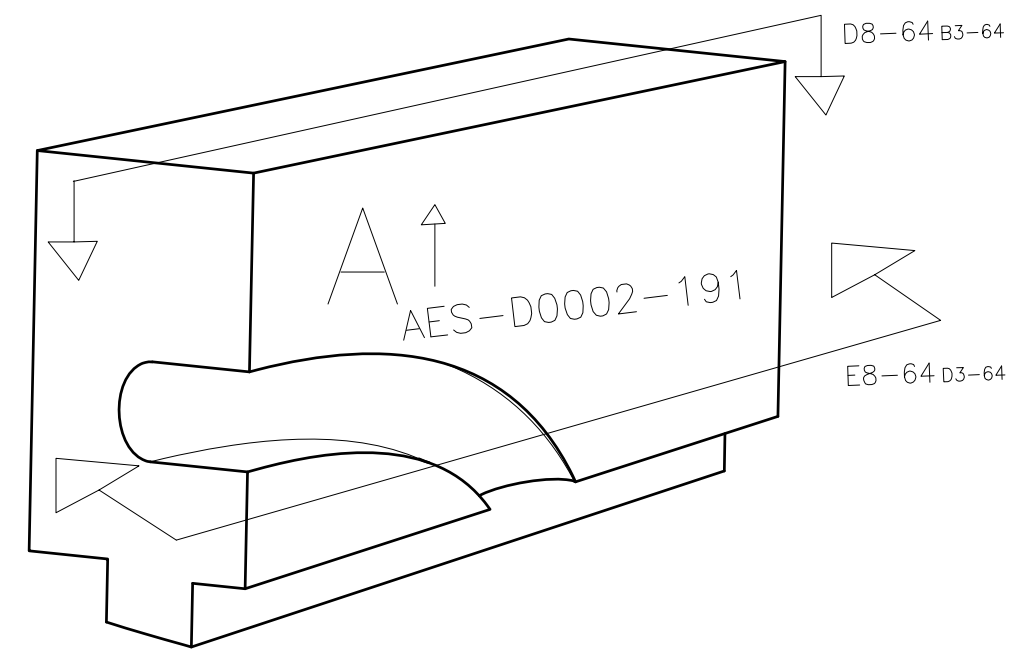
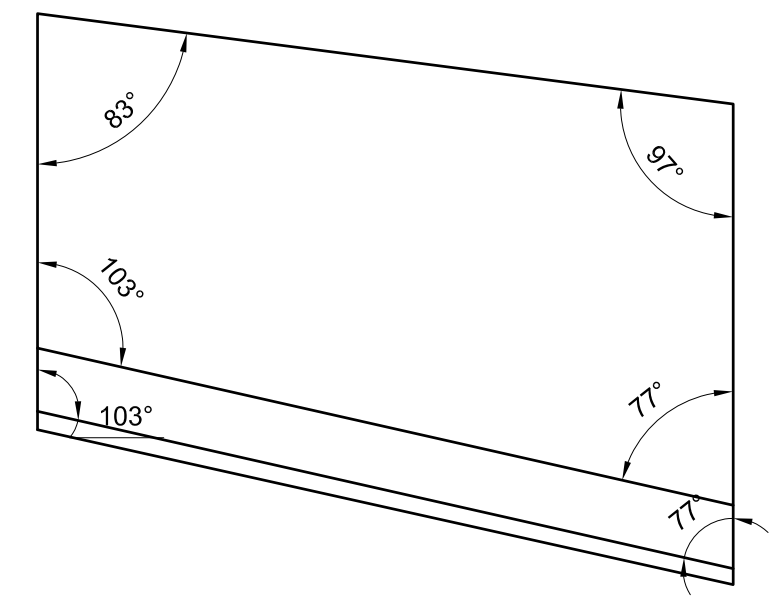
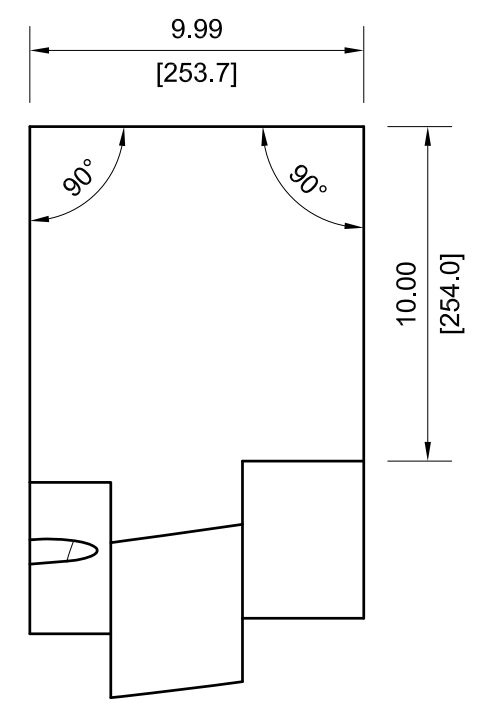

NOTE: ALL VIEWS TAKEN AS TRUE VIEWS PARALLEL TO SURFACE OF PART

		DRAWING NUMBER			
		AES-D0002			
SIZE	SCALE	SHEET	OF	REVISION	
A3	NONE	64	167	F	

-193

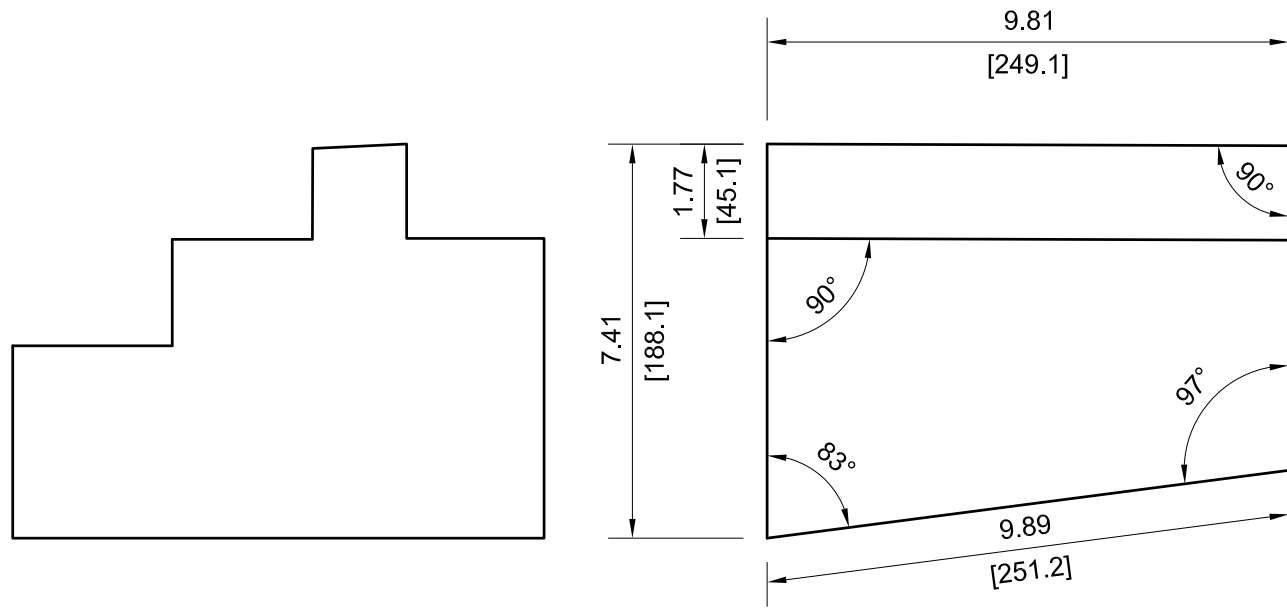

VIEW F8-65

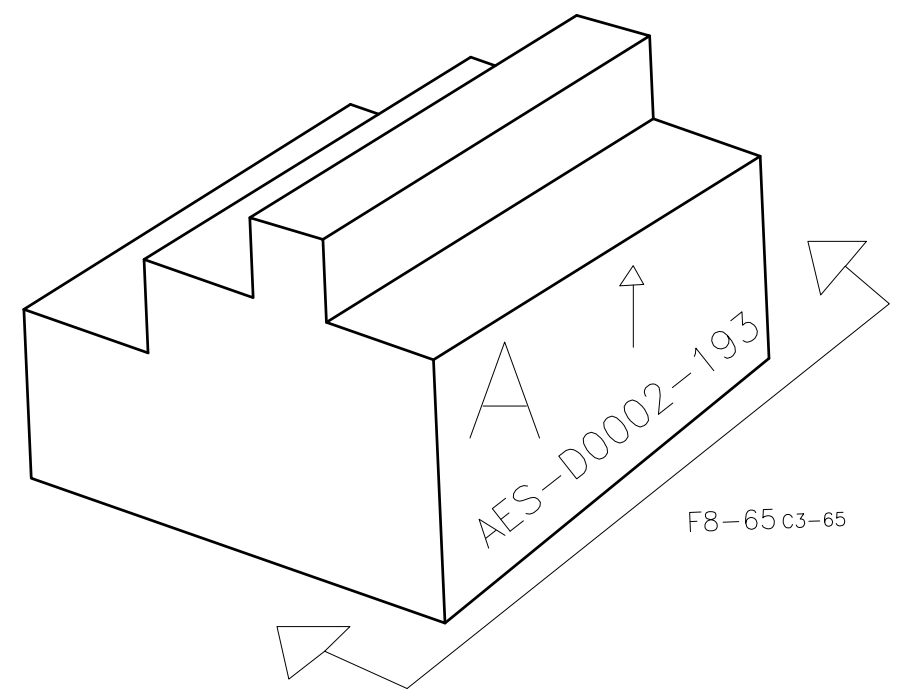
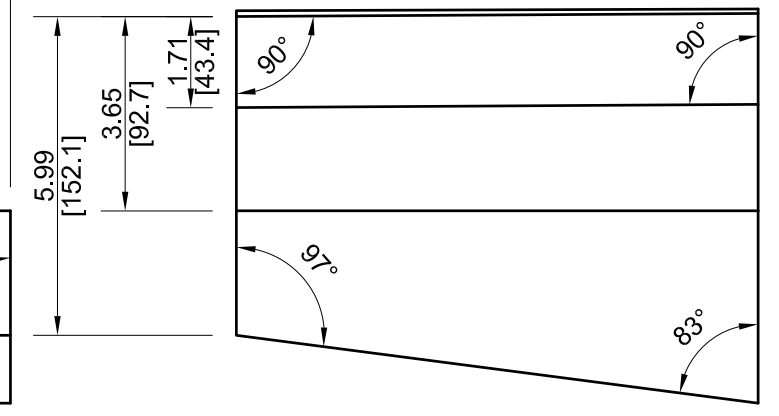
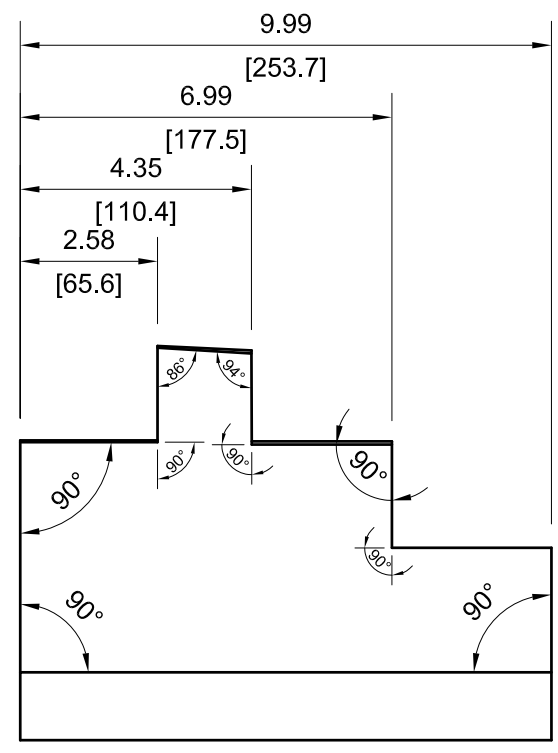

NOTE: ALL VIEWS TAKEN AS TRUE VIEWS PARALLEL TO SURFACE OF PART

	DRAWING NUMBER			
	AES-D0002			
SIZE	SCALE	SHEET	OF	REVISION
A3	NONE	65	167	F

-195

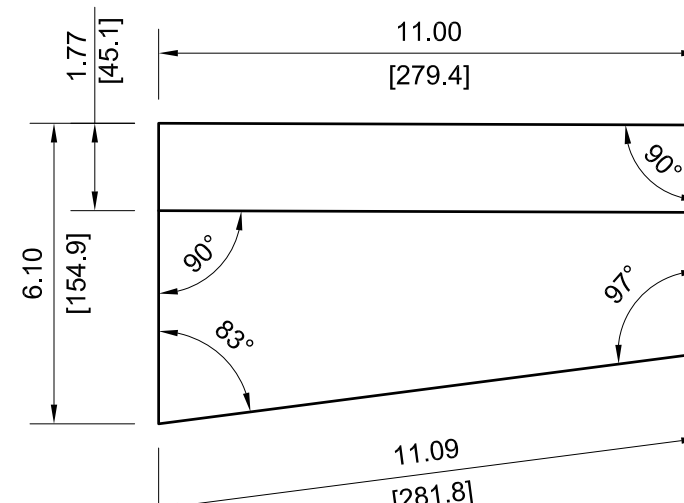
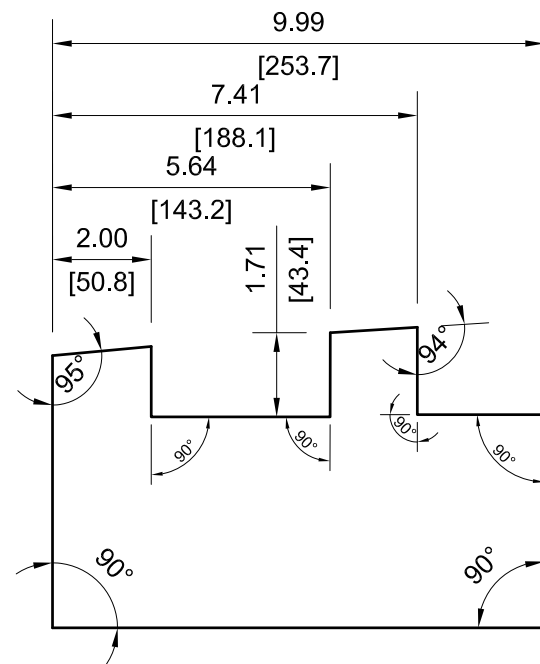
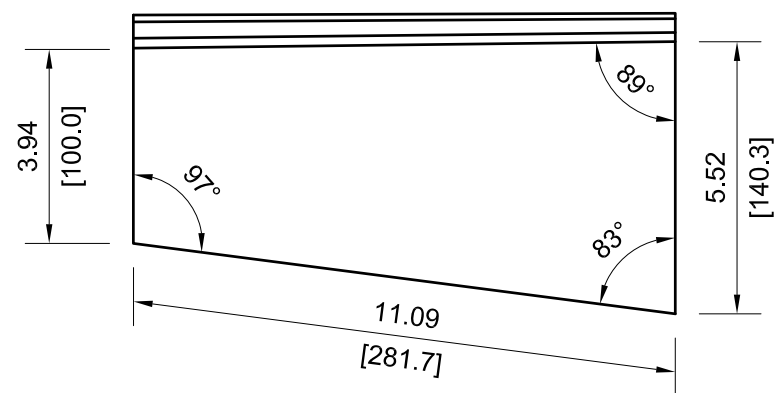
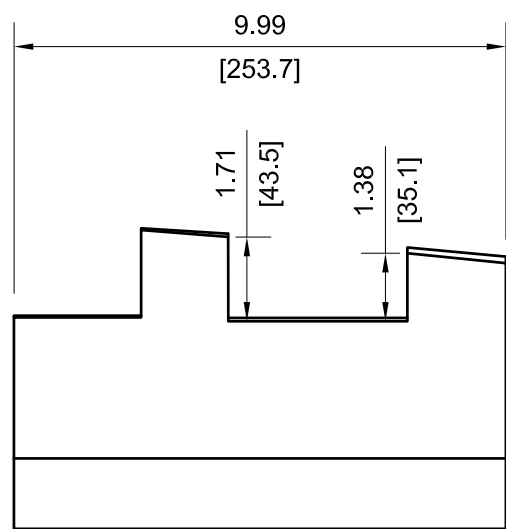

VIEW E7-66

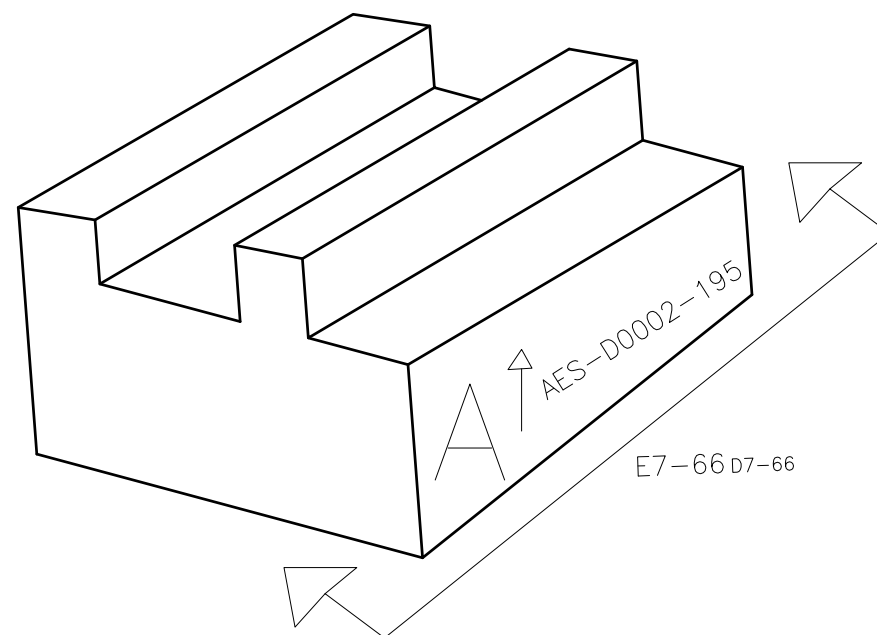

NOTE: ALL VIEWS TAKEN AS TRUE VIEWS PARALLEL TO SURFACE OF PART

		DRAWING NUMBER			
		AES-D0002			
SIZE	SCALE	SHEET	OF	REVISION	
A3	NONE	66	167	F	

-197

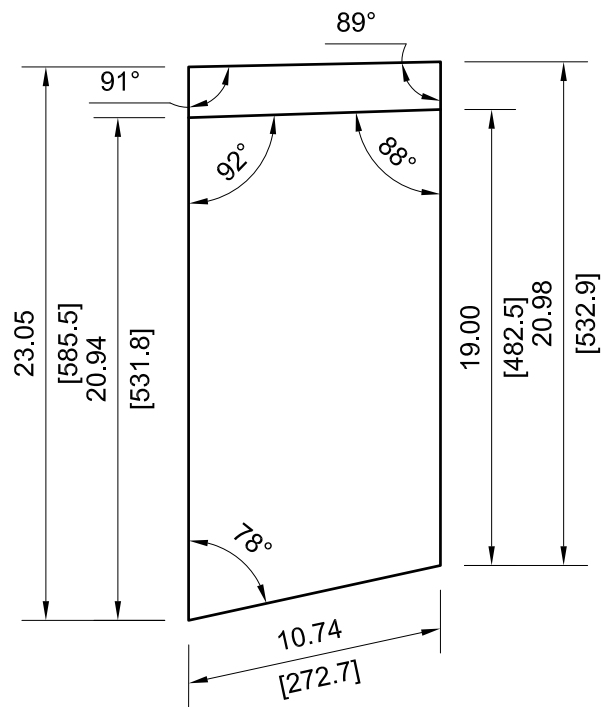
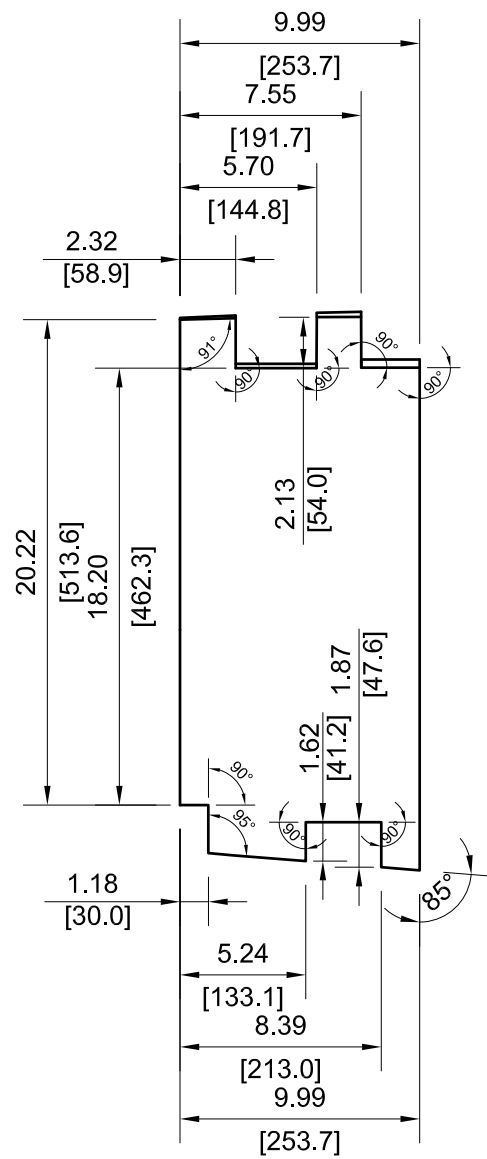
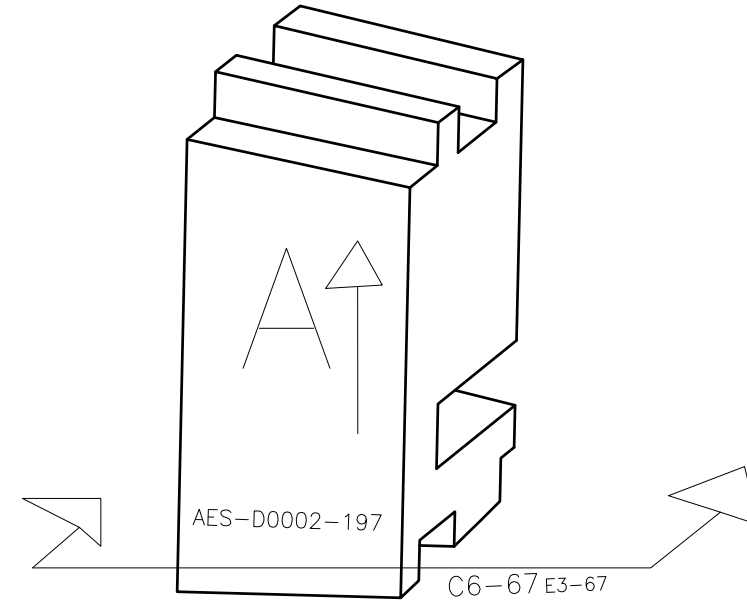

VIEW E7-67

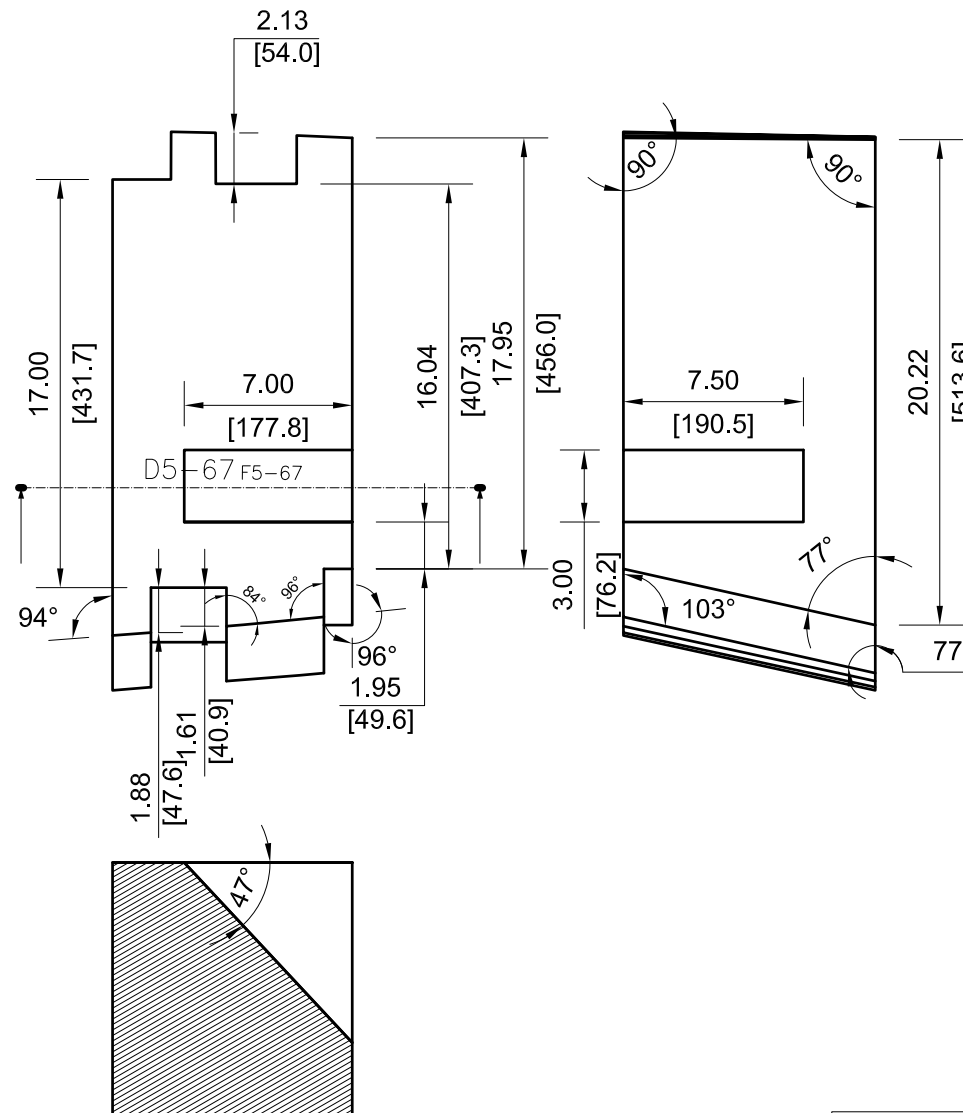

SECTION VIEW D5-67

NOTE: ALL VIEWS TAKEN AS TRUE VIEWS PARALLEL TO SURFACE OF PART

		DRAWING NUMBER			
		AES-D0002			
SIZE	SCALE	SHEET	OF	REVISION	
A3	NONE	67	167	F	

199

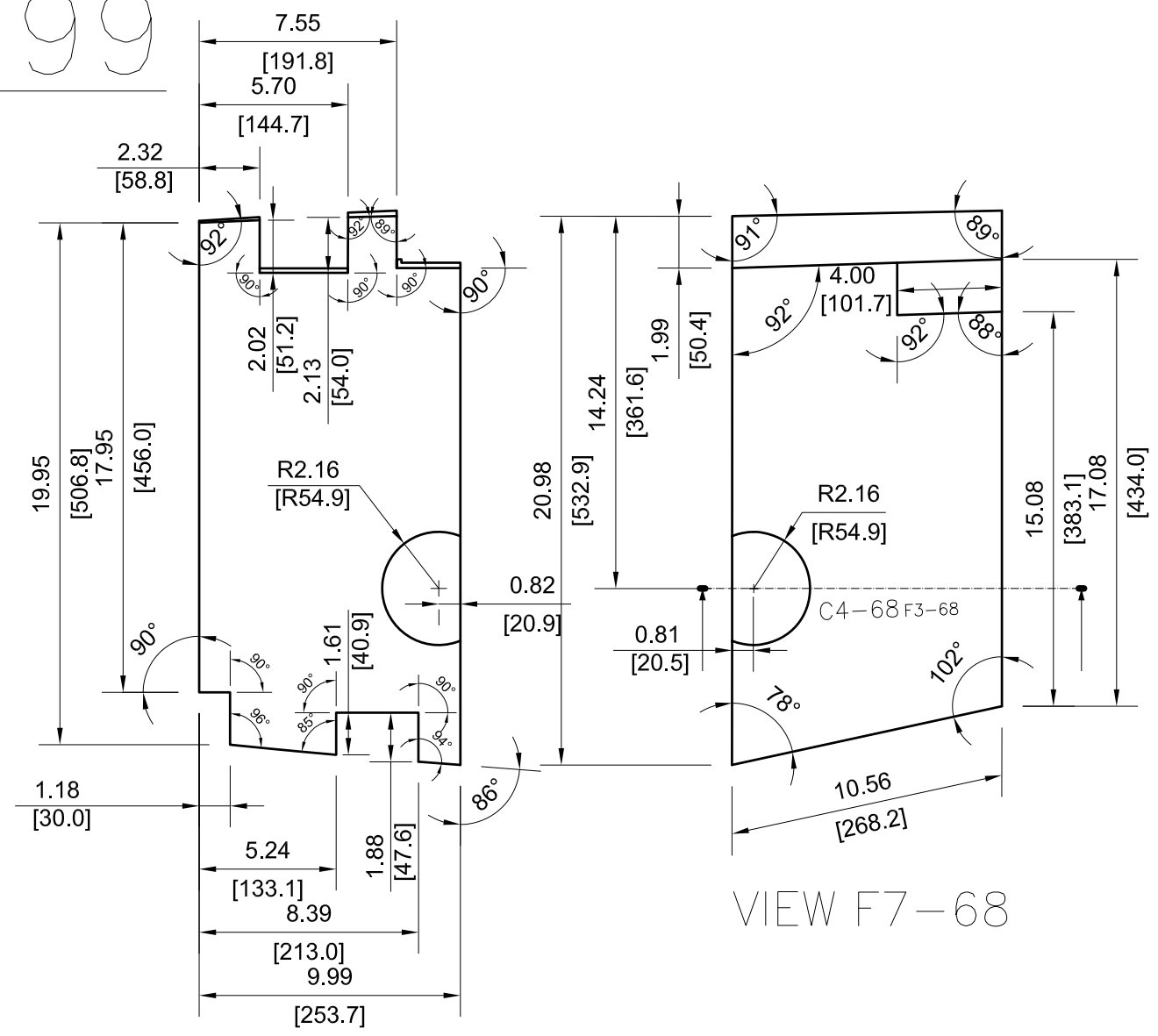

VIEW F7-68

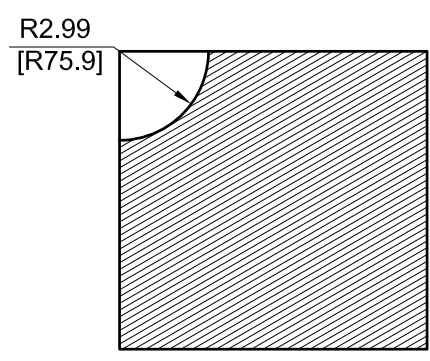

SECTION VIEW C4-68

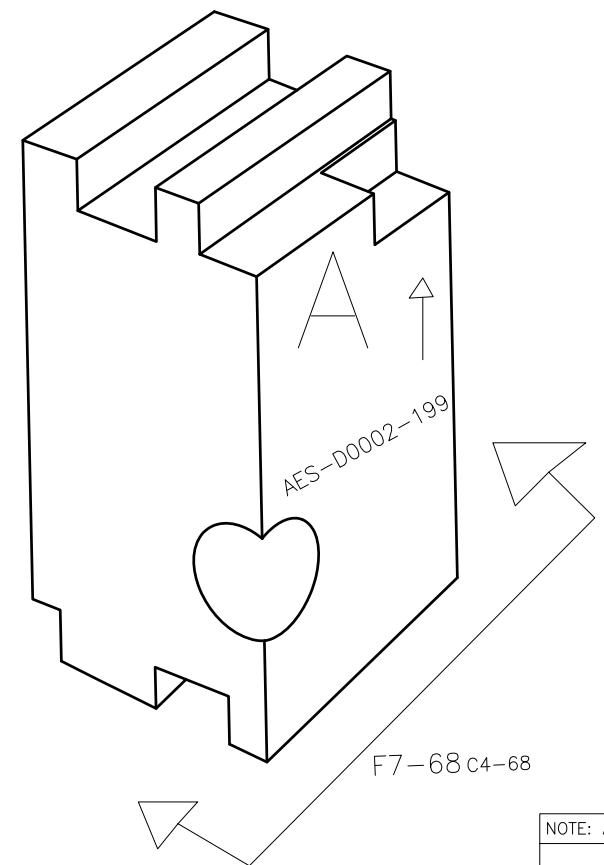
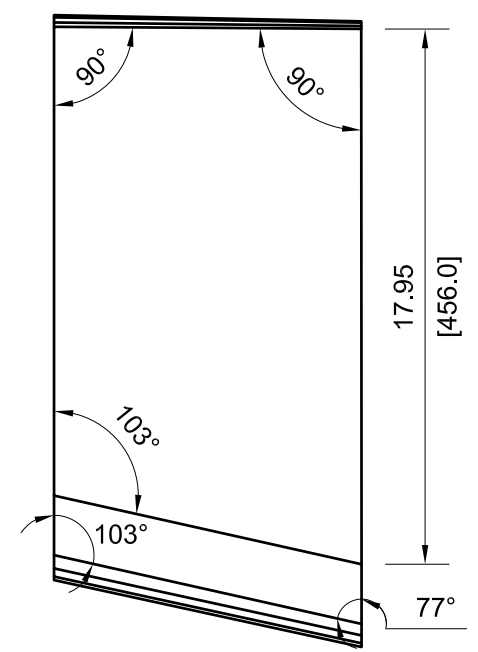
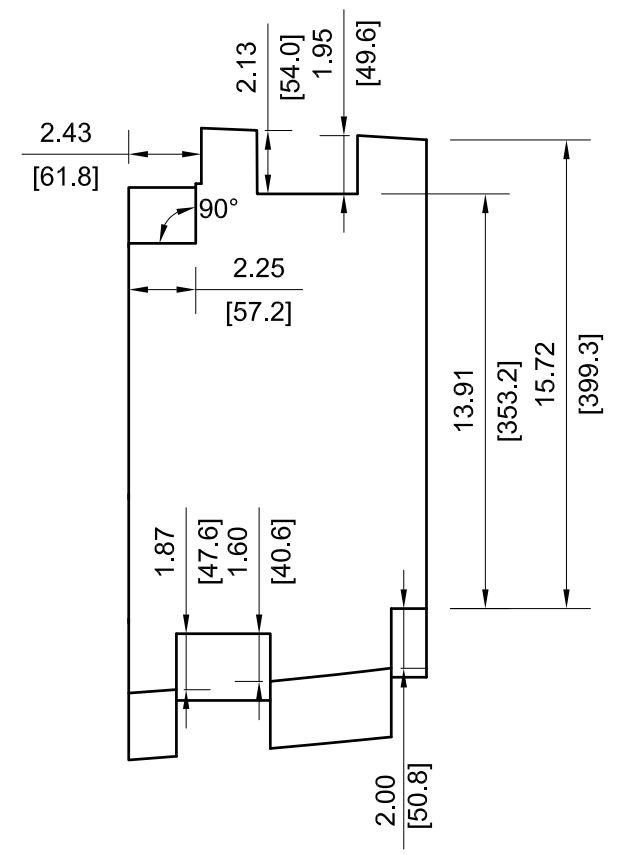

NOTE: ALL VIEWS TAKEN AS TRUE VIEWS PARALLEL TO SURFACE OF PART

		DRAWING NUMBER			
		AES-D0002			
SIZE	SCALE	SHEET	OF	REVISION	
A3	NONE	68	167	F	

-201

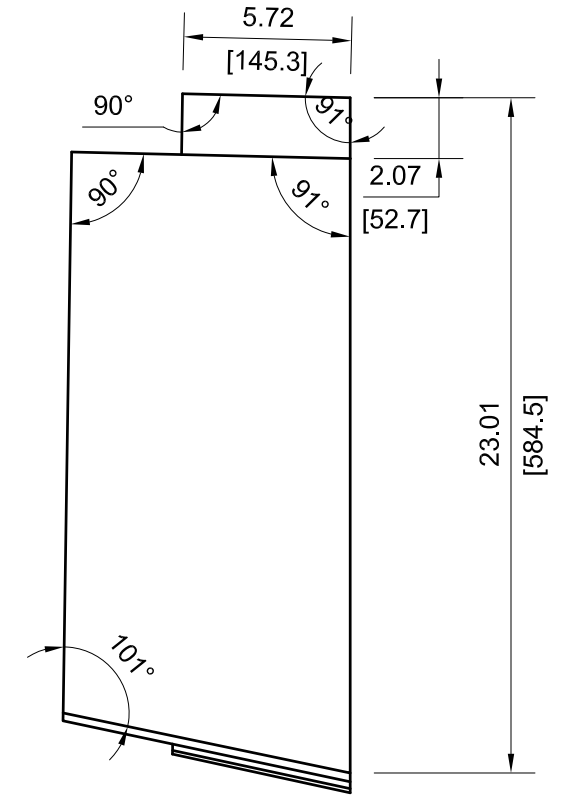
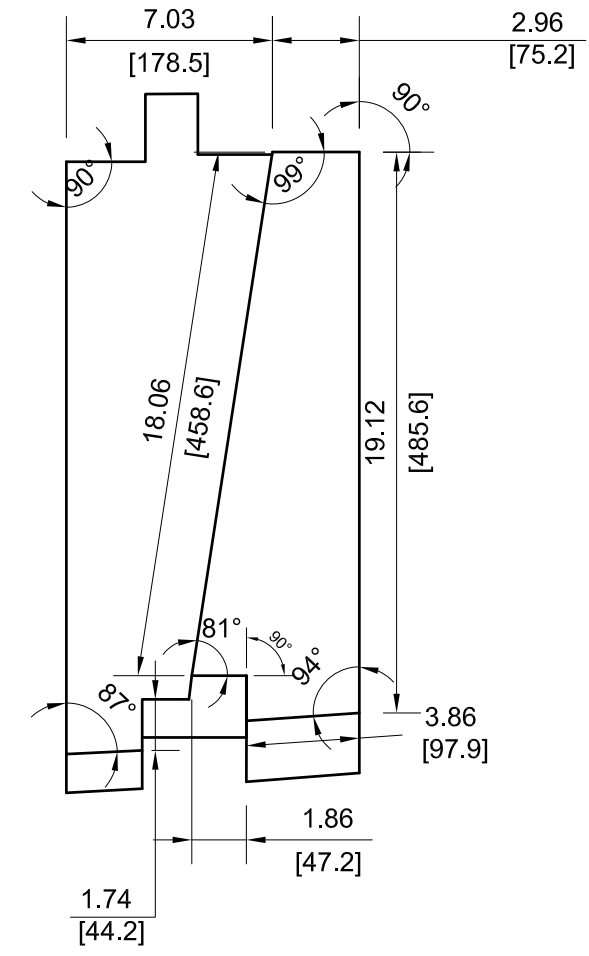
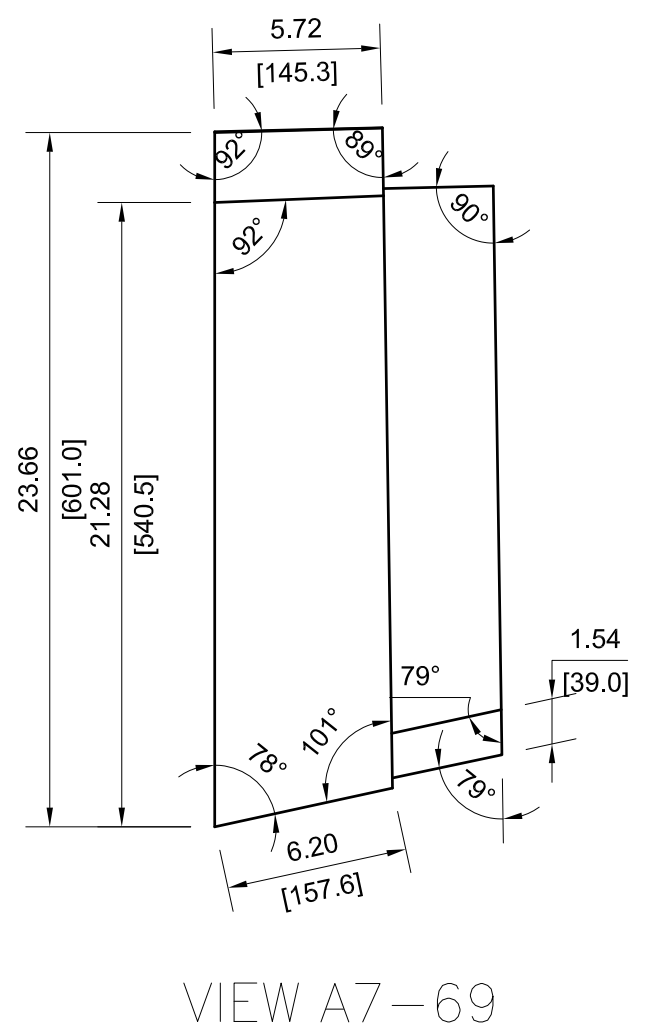
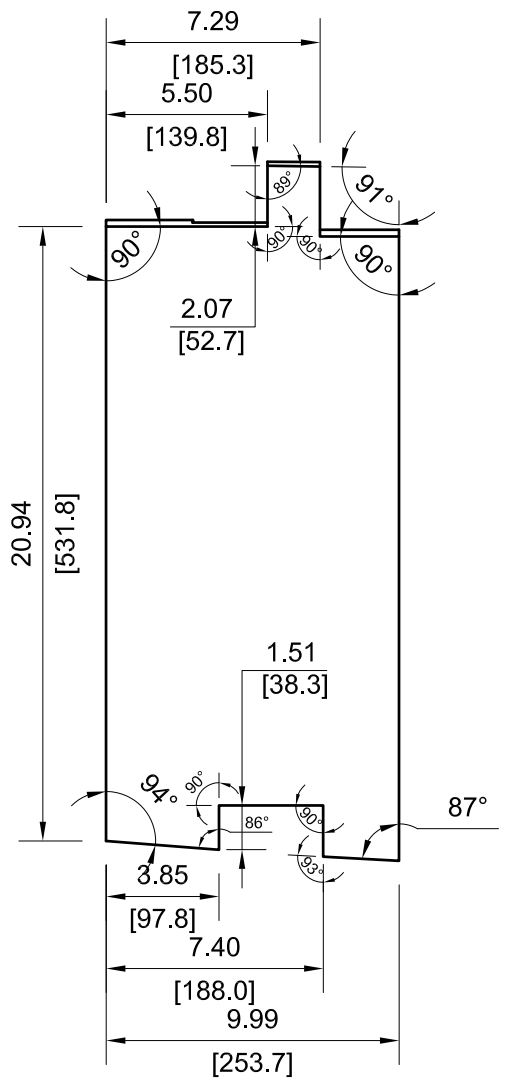
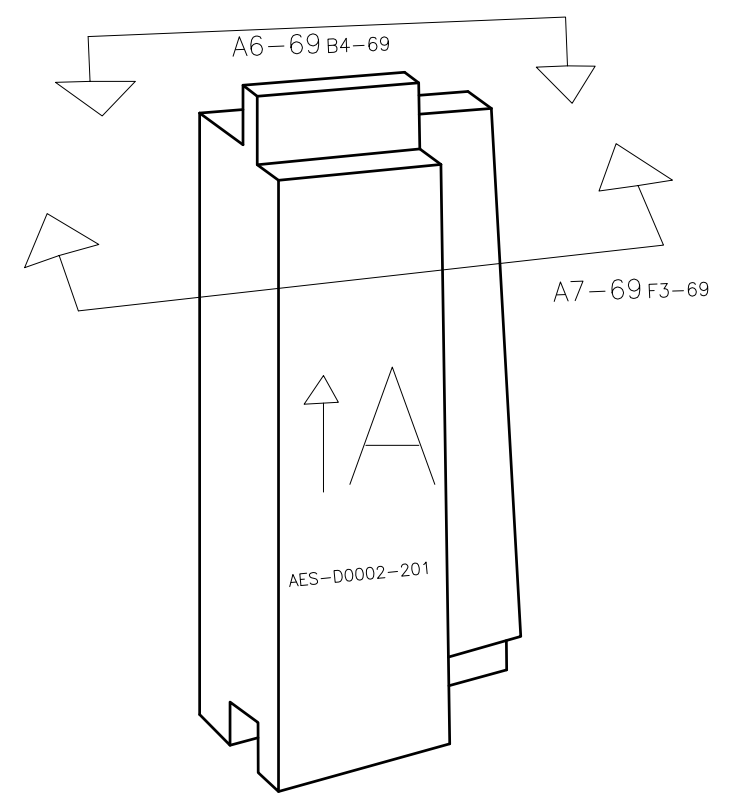
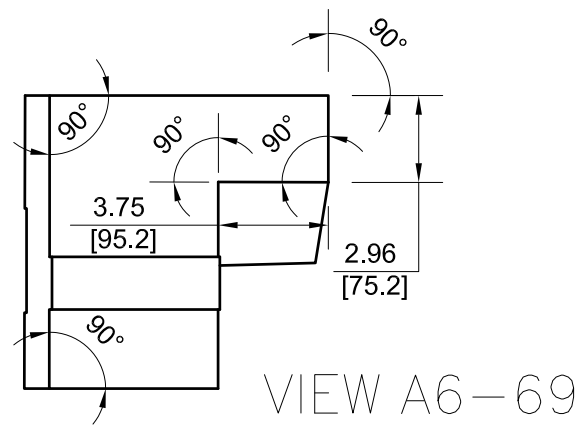

NOTE: ALL VIEWS TAKEN AS TRUE VIEWS PARALLEL TO SURFACE OF PART

		DRAWING NUMBER			
		AES-D0002			
SIZE	SCALE	SHEET	OF	REVISION	
A3	NONE	69	167	F	

-203

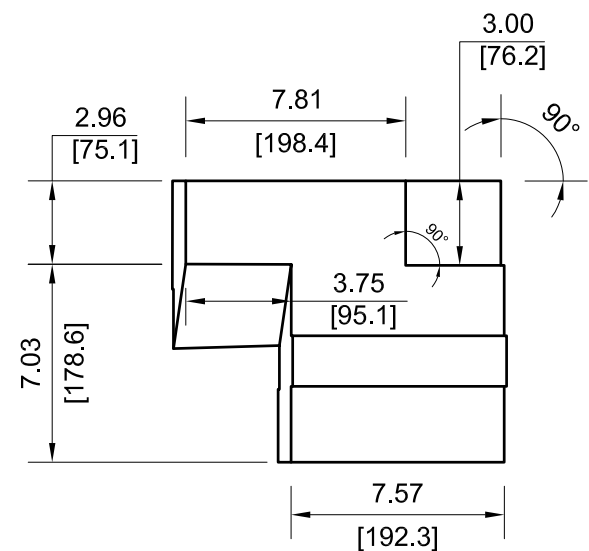

VIEW A7-70

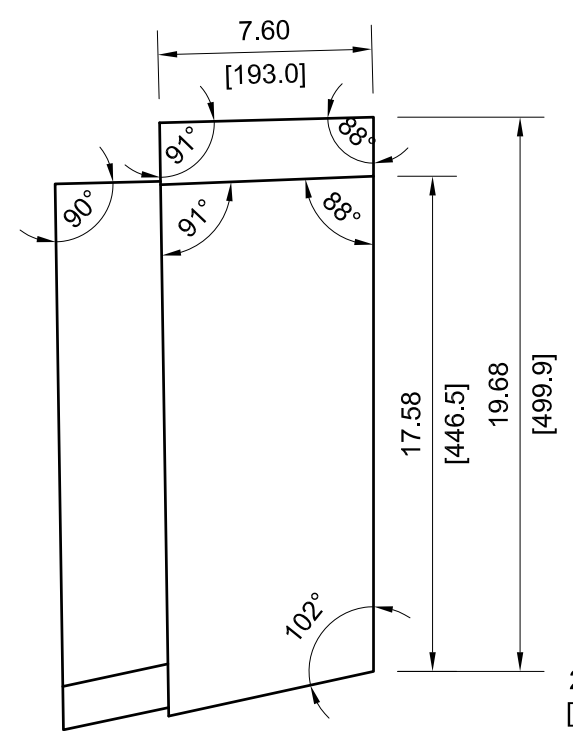
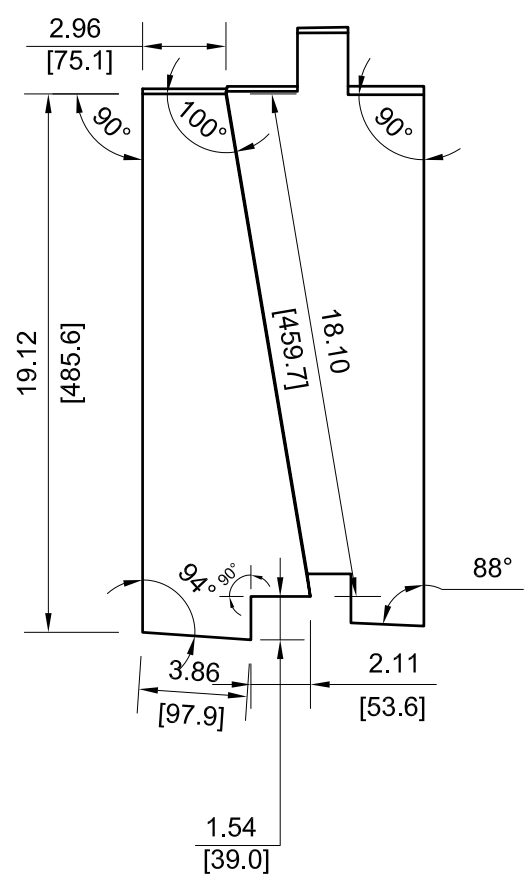
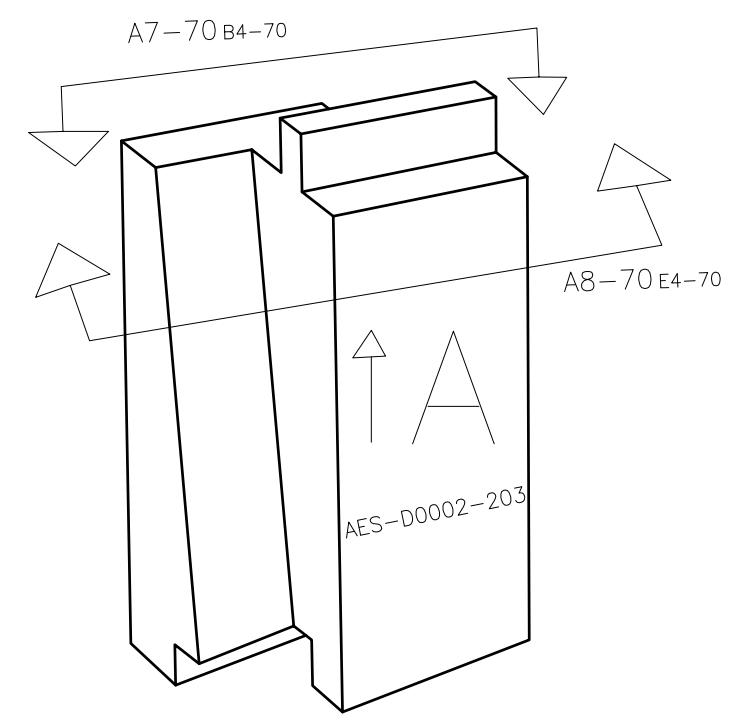

VIEW A8-70

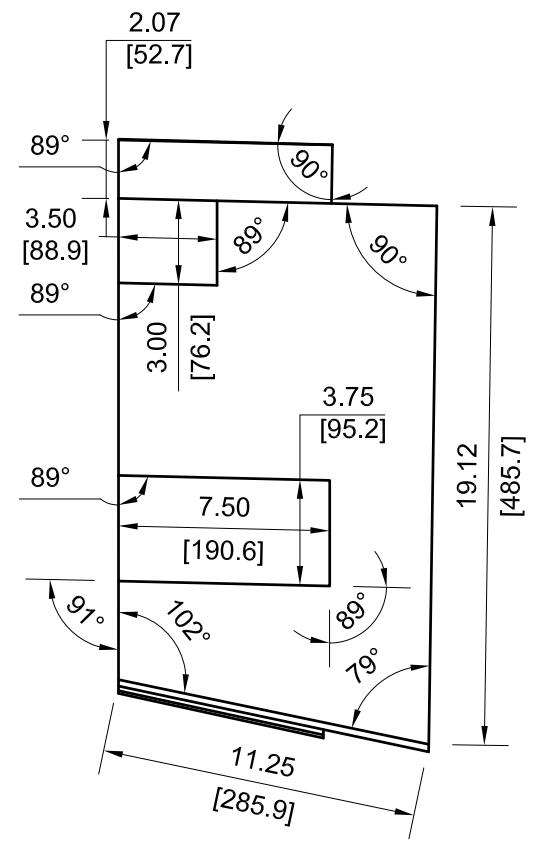
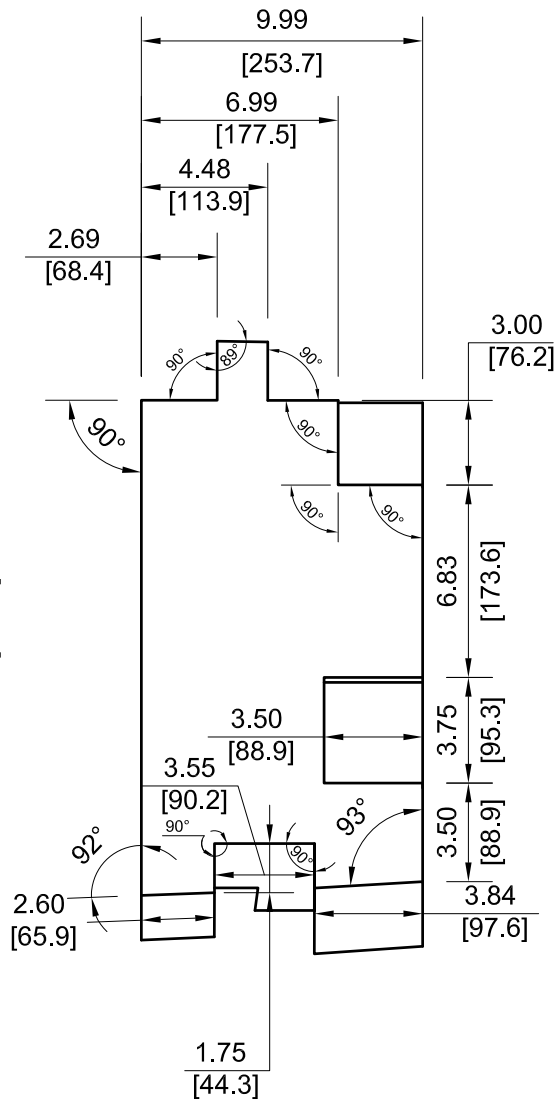

NOTE: ALL VIEWS TAKEN AS TRUE VIEWS PARALLEL TO SURFACE OF PART

	DRAWING NUMBER				
	AES-D0002				
SIZE	SCALE	SHEET	OF	REVISION	
A3	NONE	70	167	F	

-205

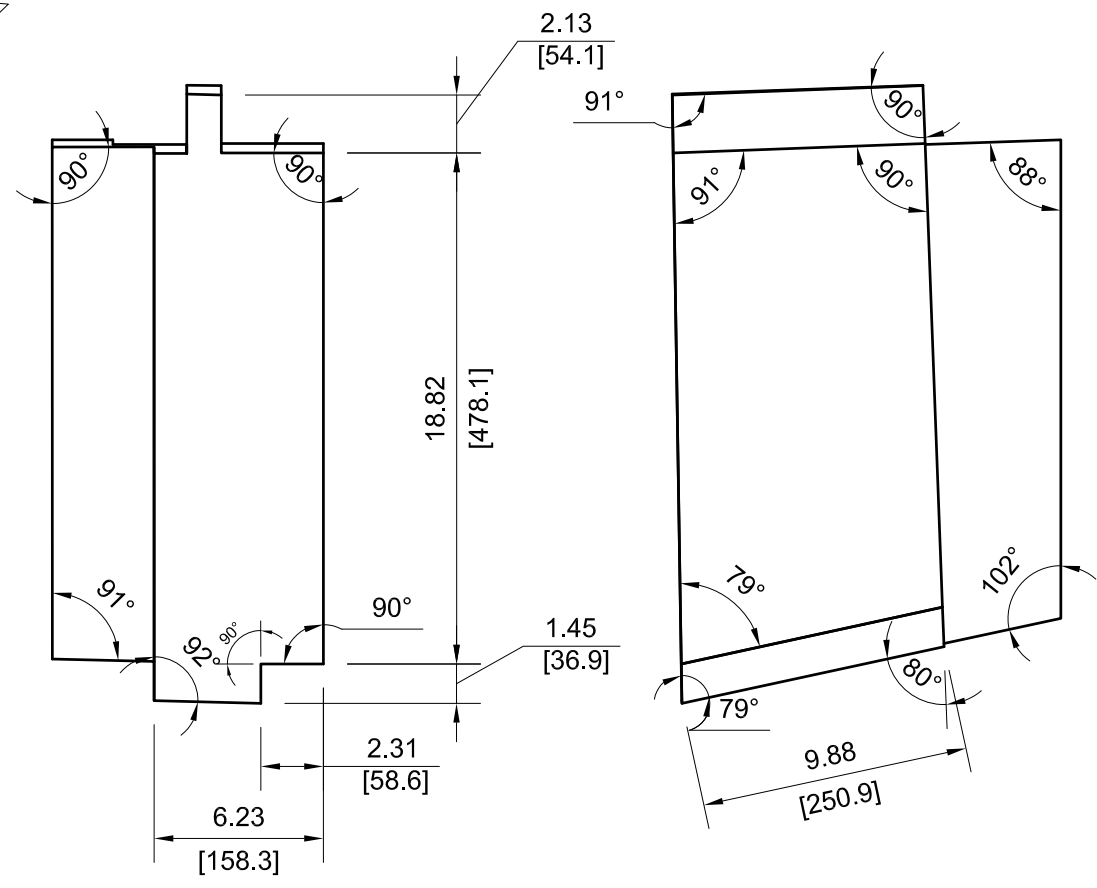
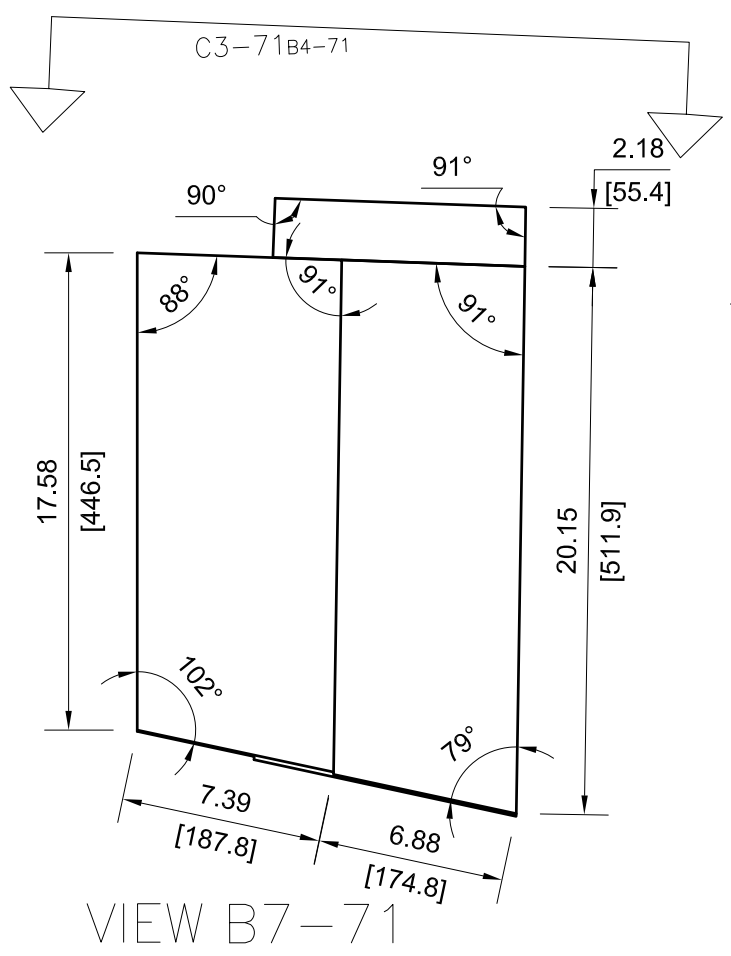
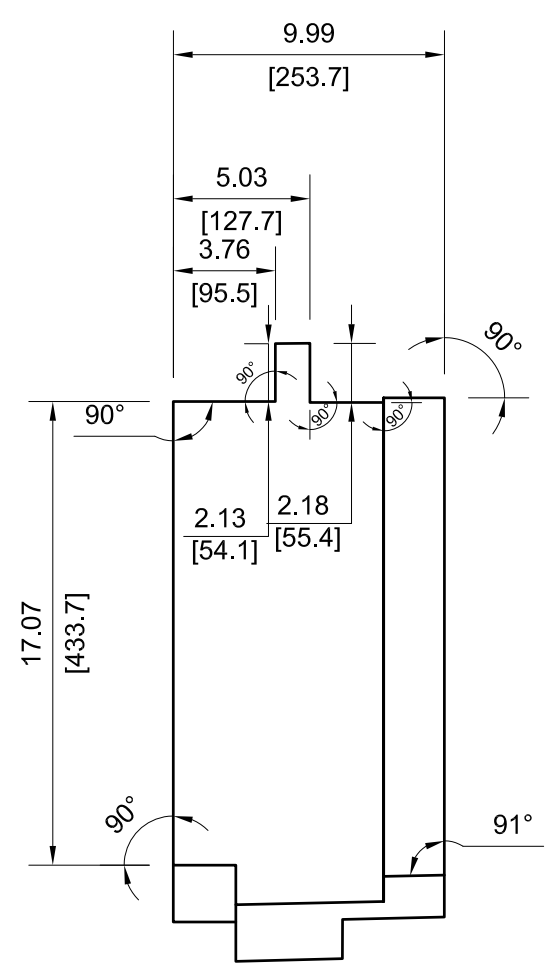
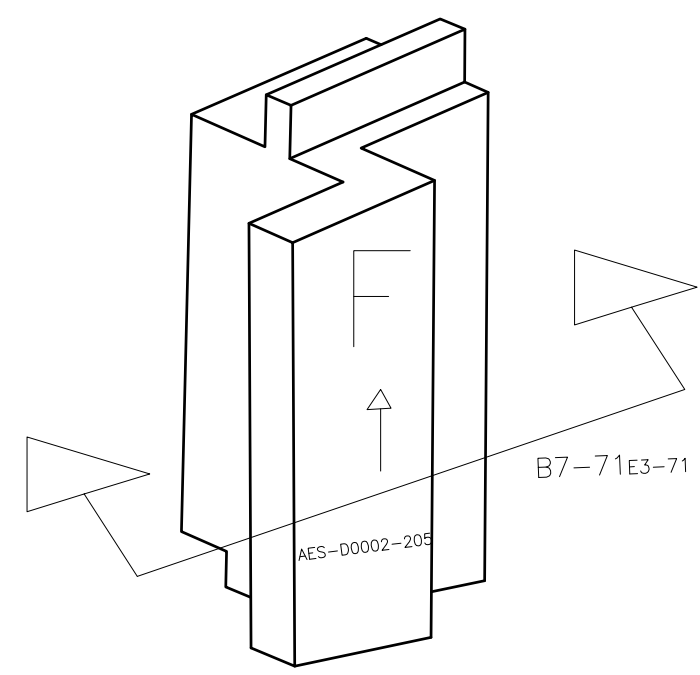
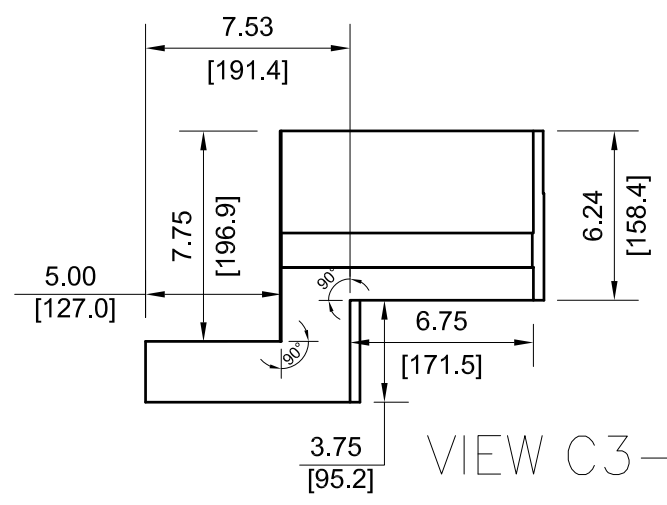

NOTE: ALL VIEWS TAKEN AS TRUE VIEWS PARALLEL TO SURFACE OF PART

		DRAWING NUMBER			
		AES-D0002			
SIZE	SCALE	SHEET	OF	REVISION	
A3	NONE	71	167	F	

-207

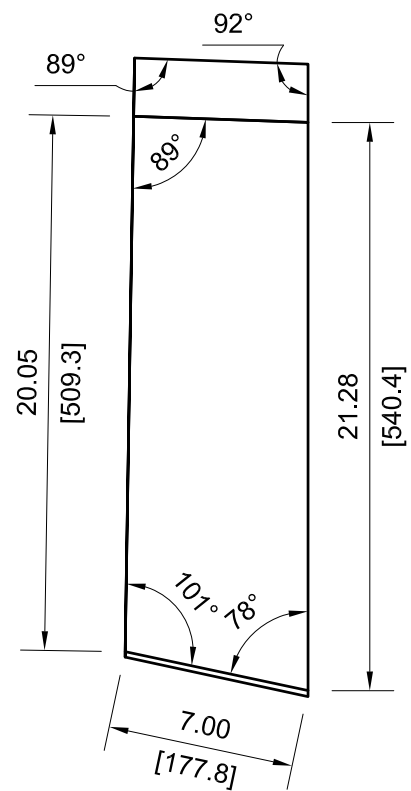
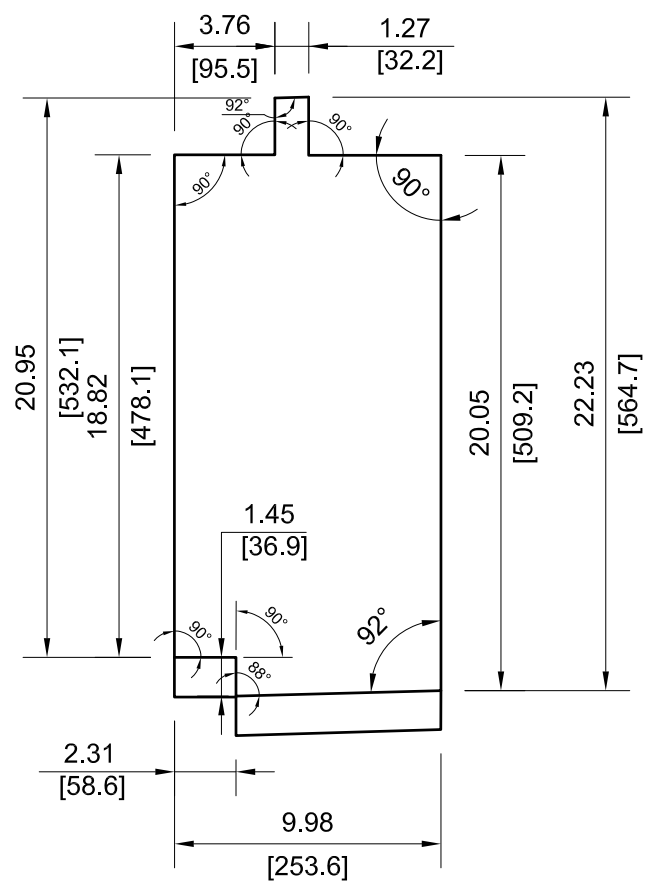

VIEW E7-72

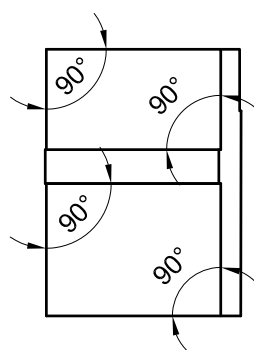
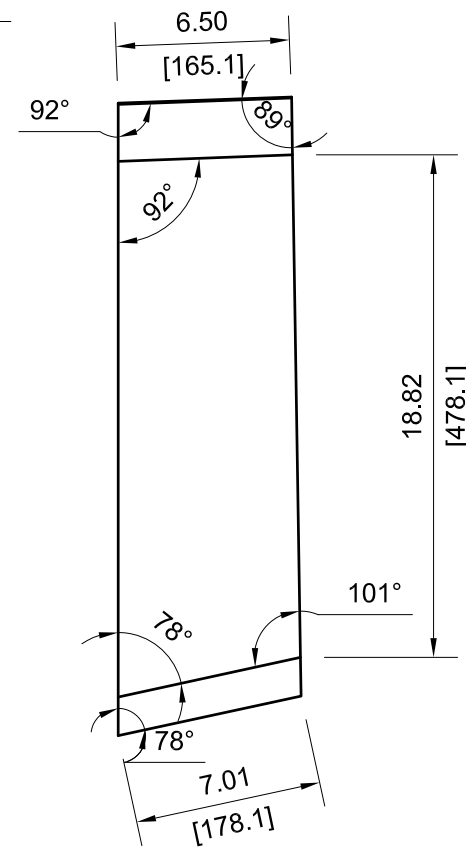
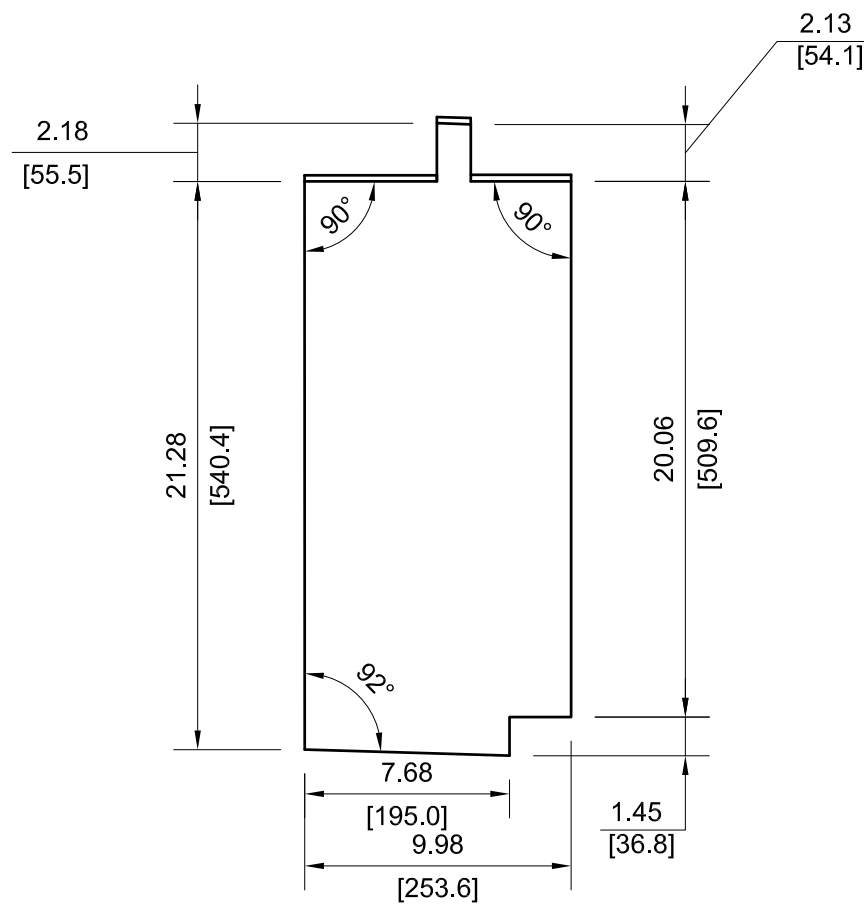

VIEW D6-72

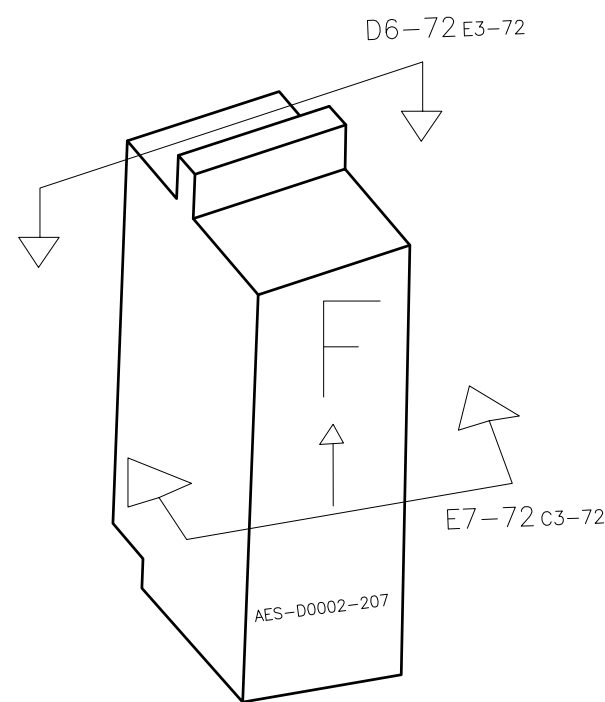

NOTE: ALL VIEWS TAKEN AS TRUE VIEWS PARALLEL TO SURFACE OF PART

		DRAWING NUMBER			
		AES-D0002			
SIZE	SCALE	SHEET	OF	REVISION	
A3	NONE	72	167	F	

-209

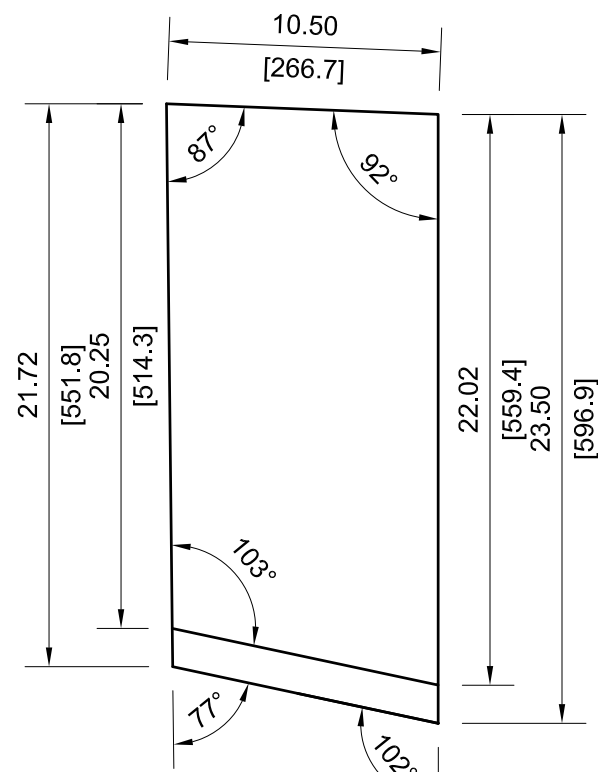
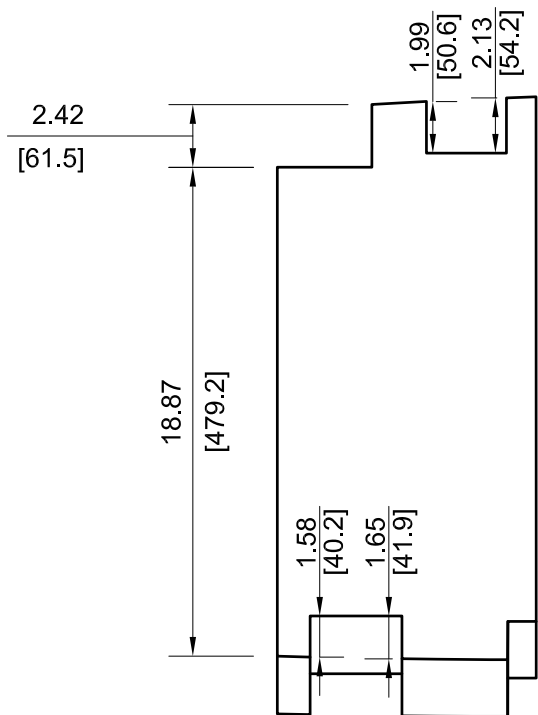

VIEW E8-73

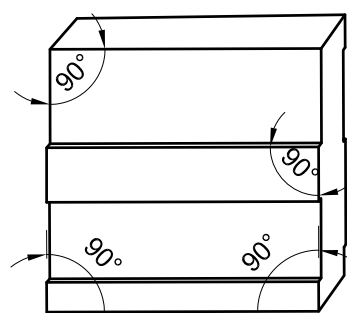

VIEW D8-73

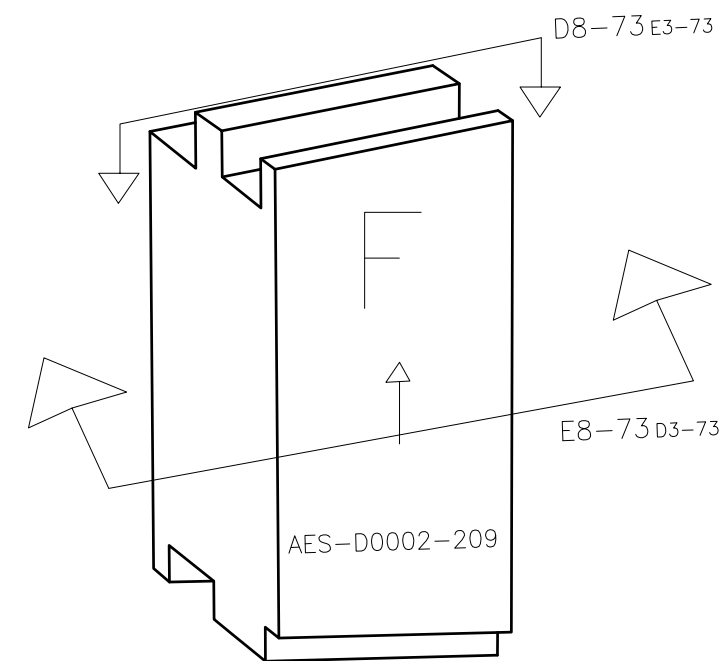
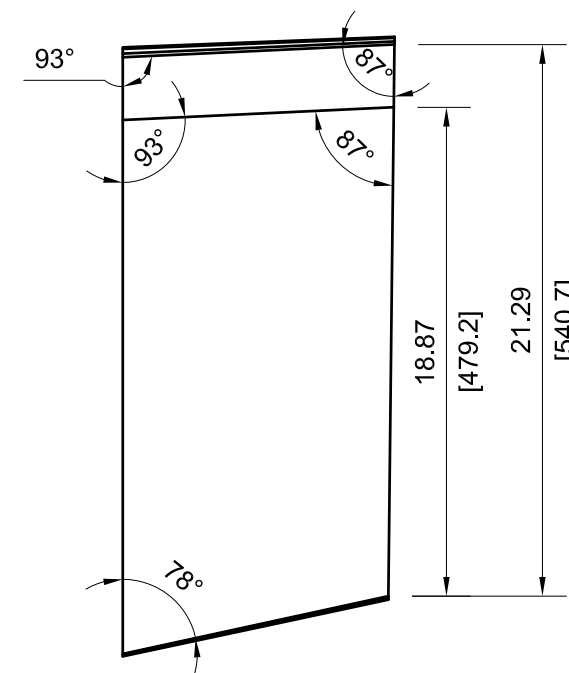
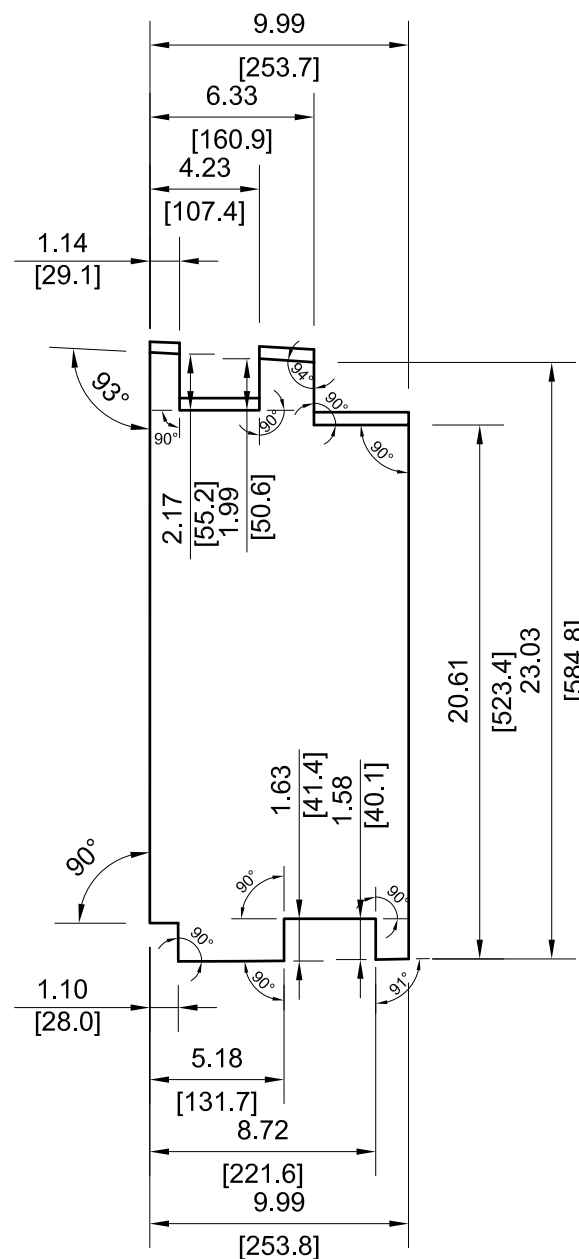

NOTE: ALL VIEWS TAKEN AS TRUE VIEWS PARALLEL TO SURFACE OF PART

	DRAWING NUMBER				
	AES-D0002				
SIZE	SCALE	SHEET	OF	REVISION	
A3	NONE	73	167	F	

-211

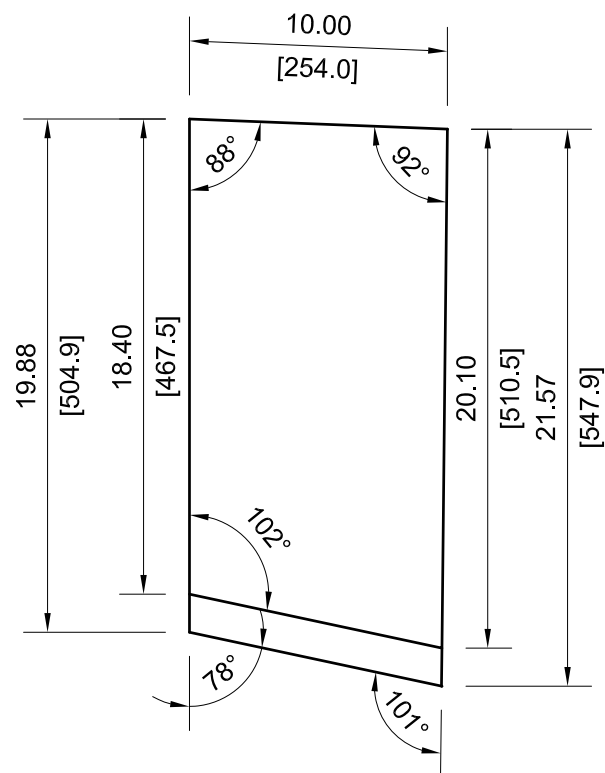
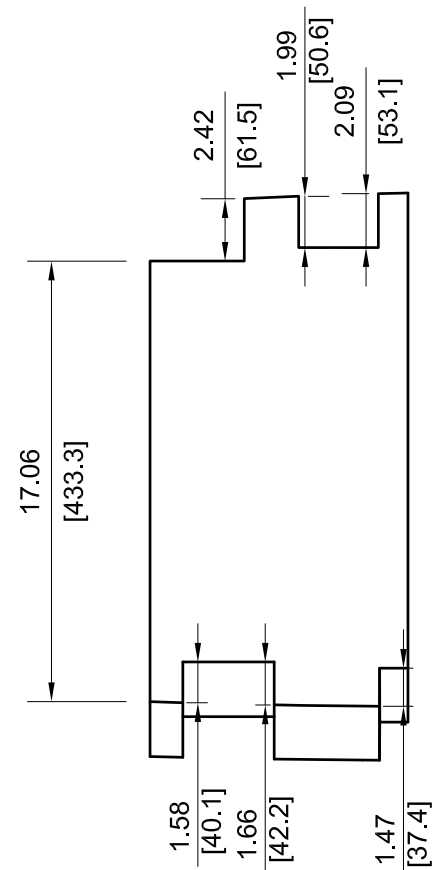

VIEW E8-74

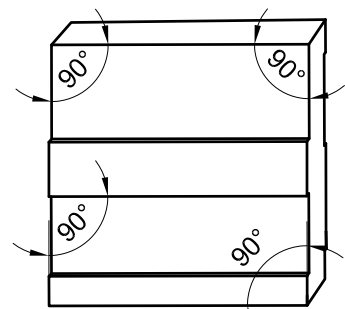

VIEW D8-74

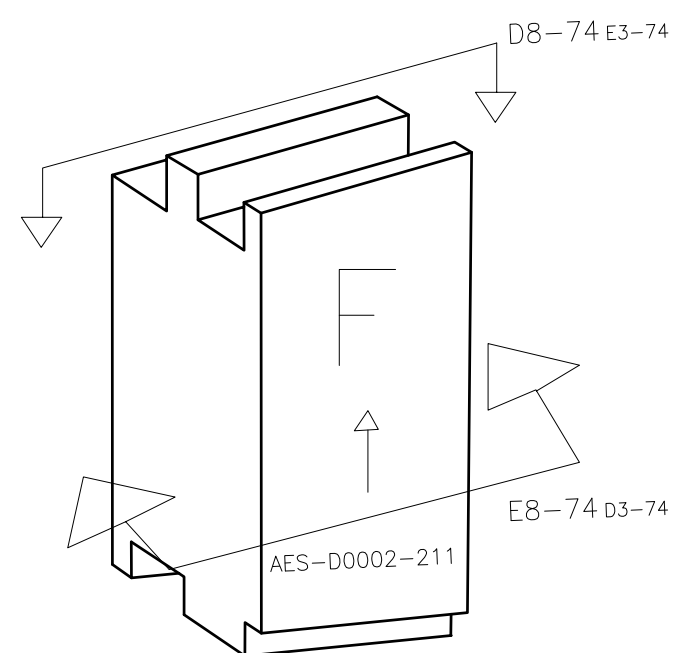
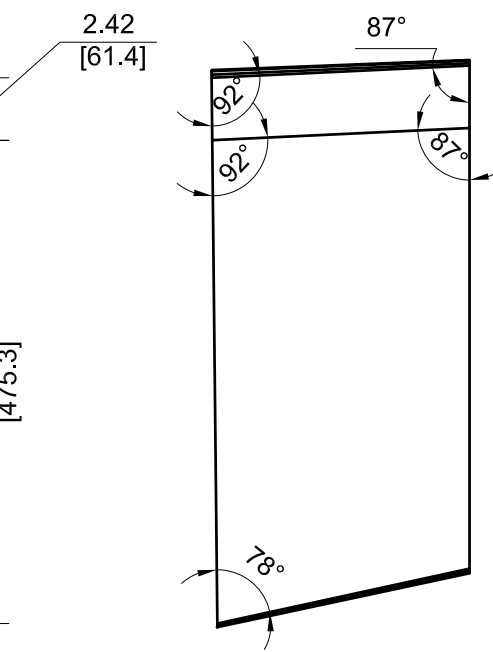
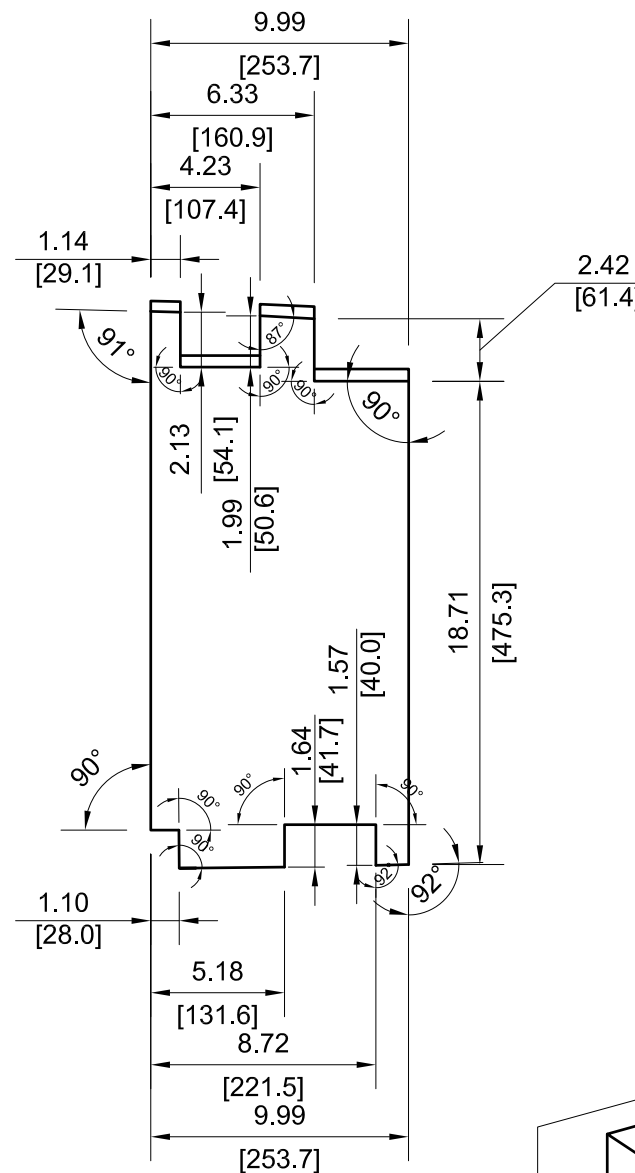

NOTE: ALL VIEWS TAKEN AS TRUE VIEWS PARALLEL TO SURFACE OF PART

		DRAWING NUMBER			
		AES-D0002			
SIZE	SCALE	SHEET	OF	REVISION	
A3	NONE	74	167	F	

-213

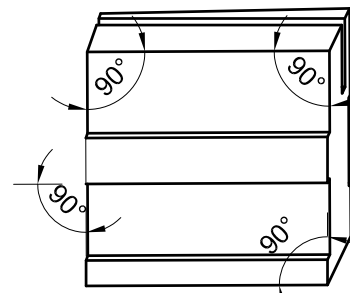

VIEW A7-75

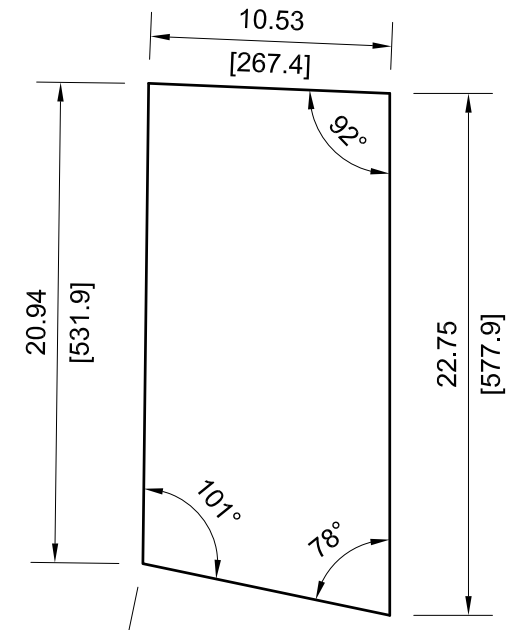
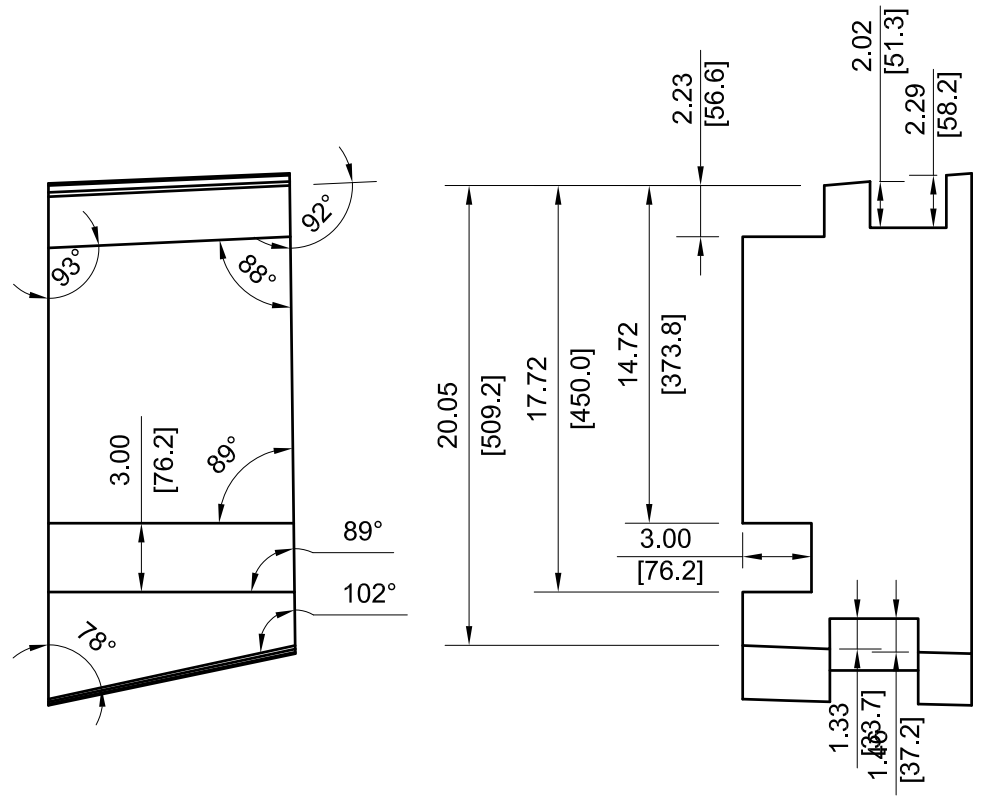
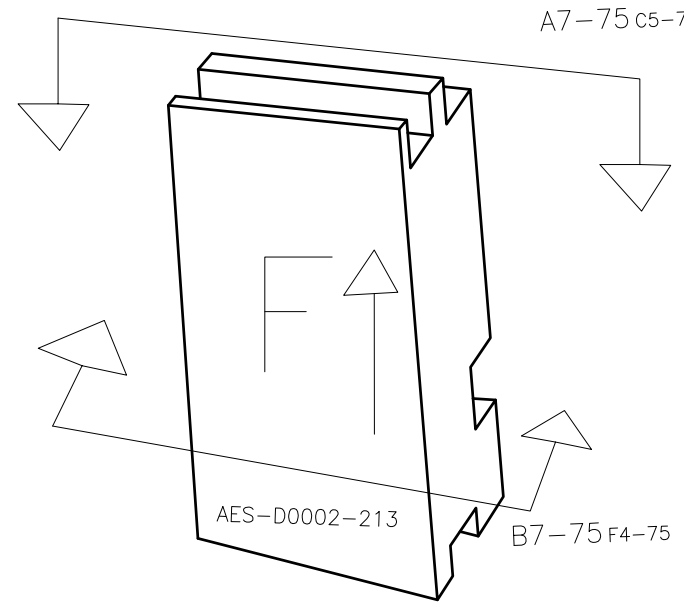

VIEW B7-75

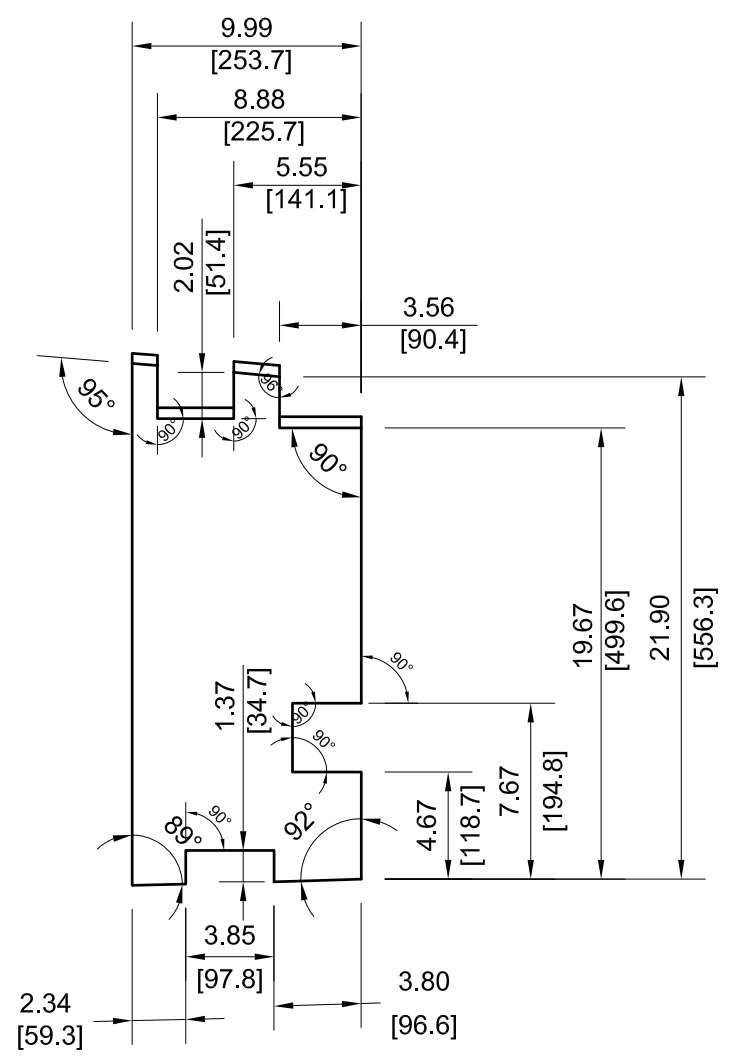

NOTE: ALL VIEWS TAKEN AS TRUE VIEWS PARALLEL TO SURFACE OF PART

		DRAWING NUMBER			
		AES-D0002			
SIZE	SCALE	SHEET	OF	REVISION	
A3	NONE	75	167	F	

-215

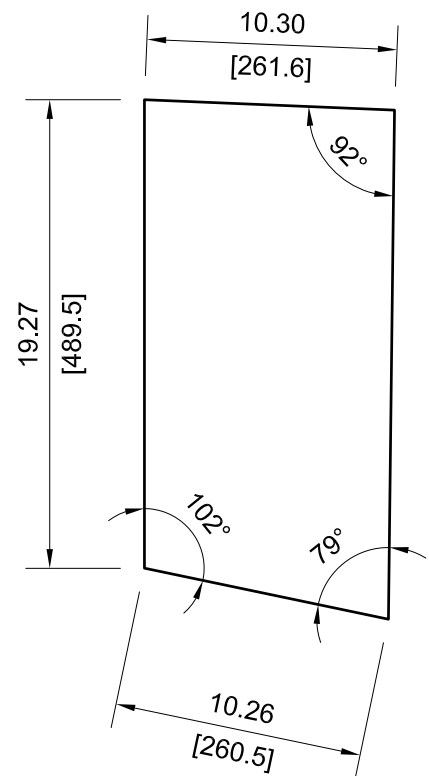
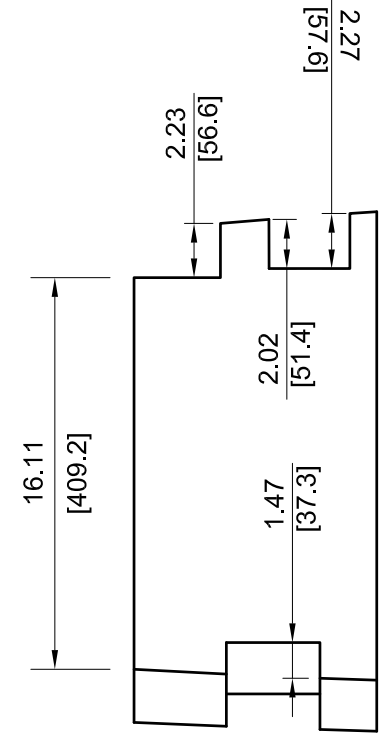
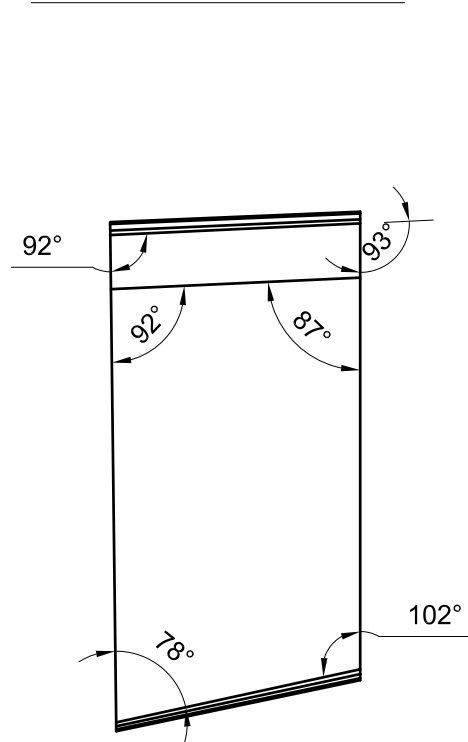

VIEW E8-76

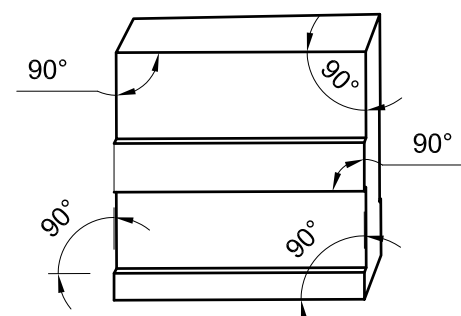
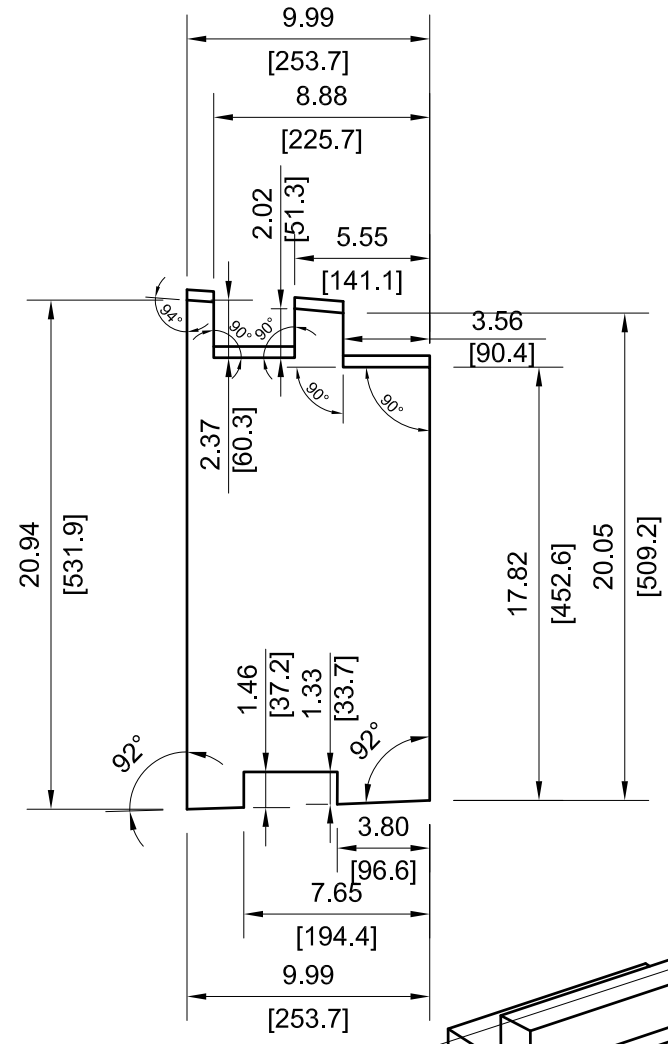

VIEW D7-76

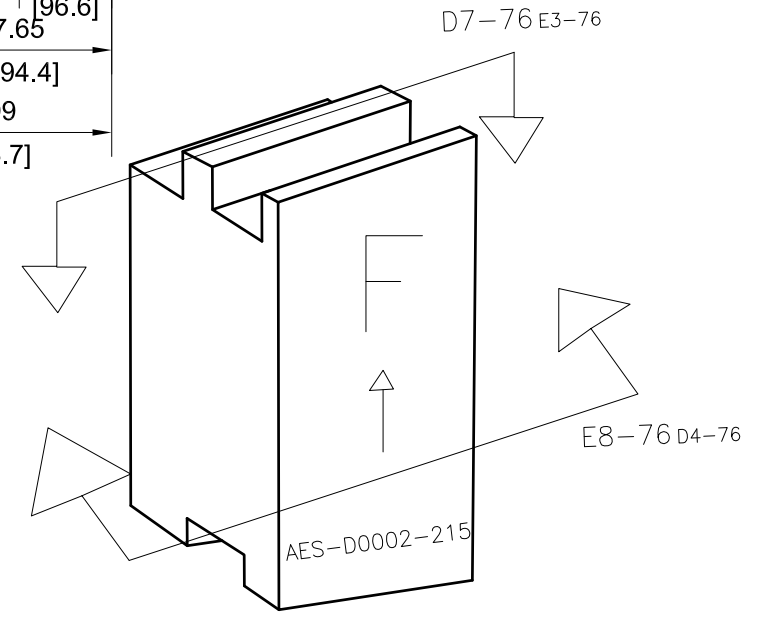

NOTE: ALL VIEWS TAKEN AS TRUE VIEWS PARALLEL TO SURFACE OF PART

	DRAWING NUMBER				
	AES-D0002				
SIZE	SCALE	SHEET	OF	REVISION	
A3	NONE	76	167	F	

-217

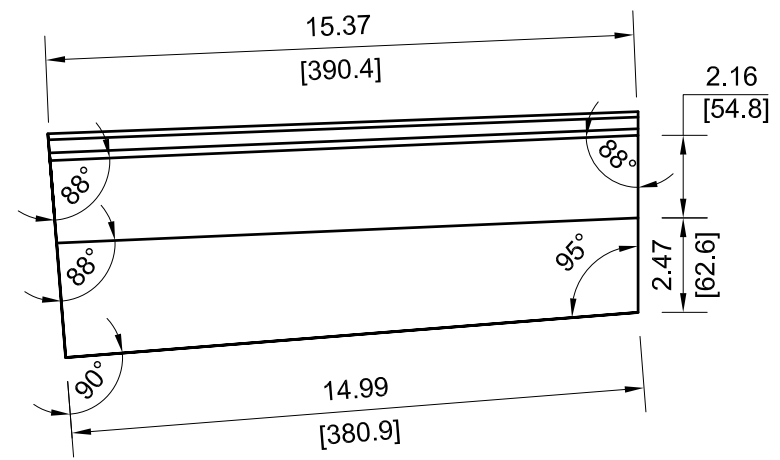
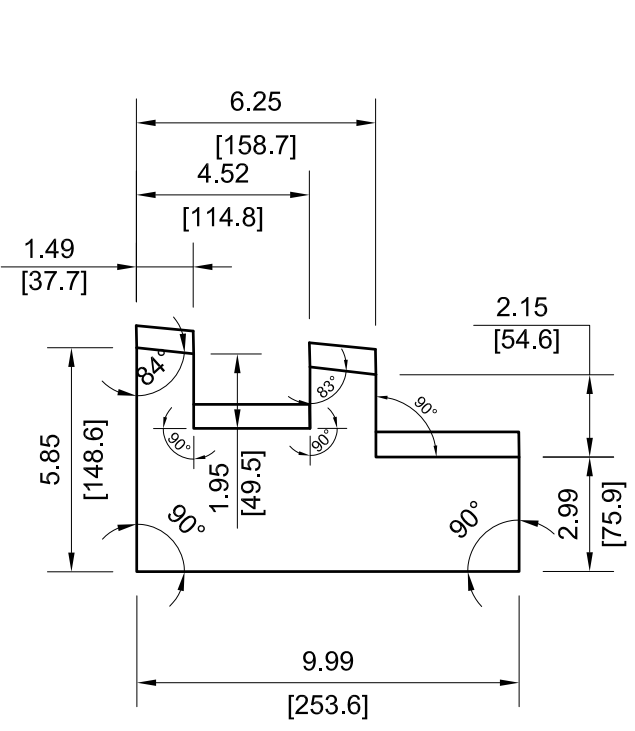

VIEW D8-77

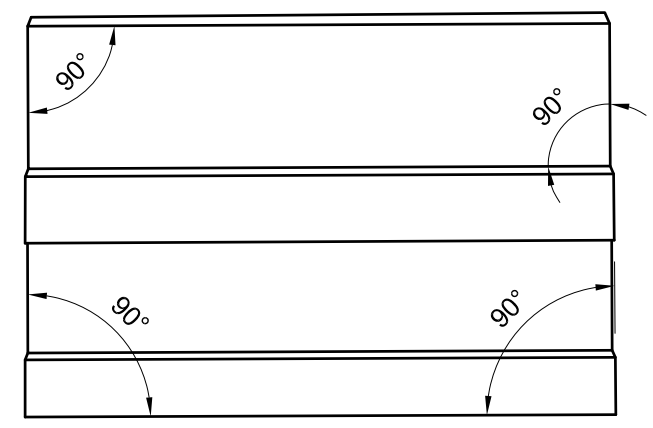
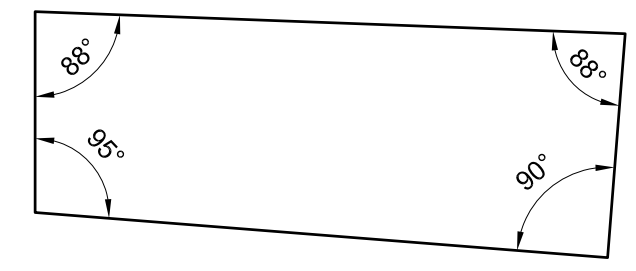
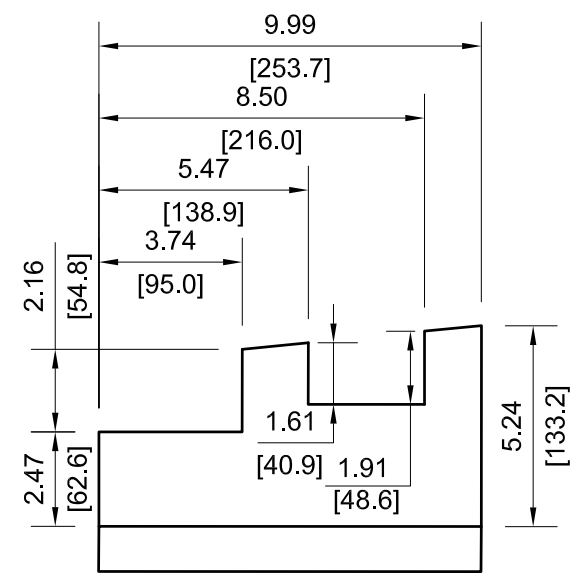

VIEW D7-77

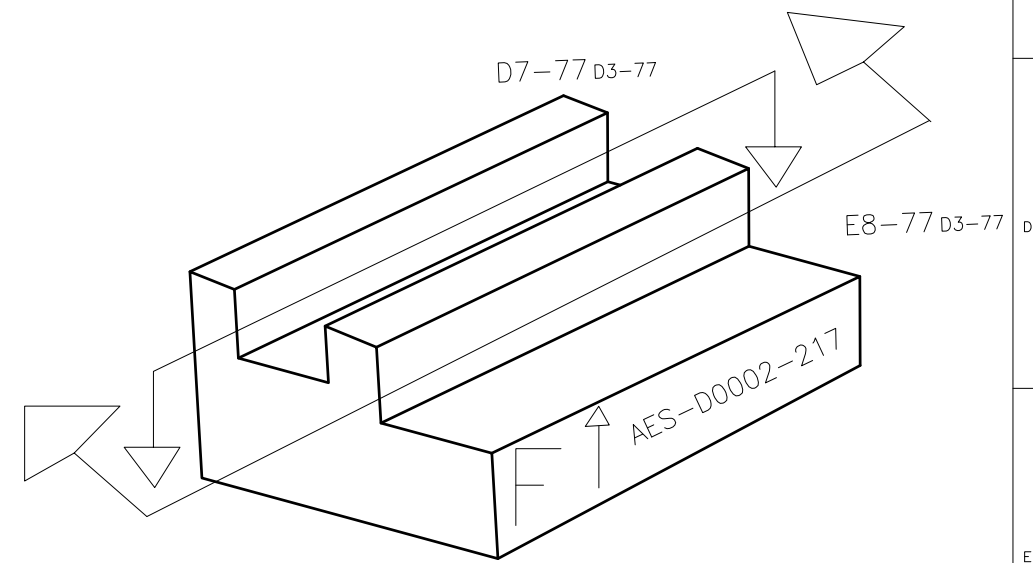

NOTE: ALL VIEWS TAKEN AS TRUE VIEWS PARALLEL TO SURFACE OF PART

	DRAWING NUMBER				
	AES-D0002				
SIZE	SCALE	SHEET	OF	REVISION	
A3	NONE	77	167	F	

-219

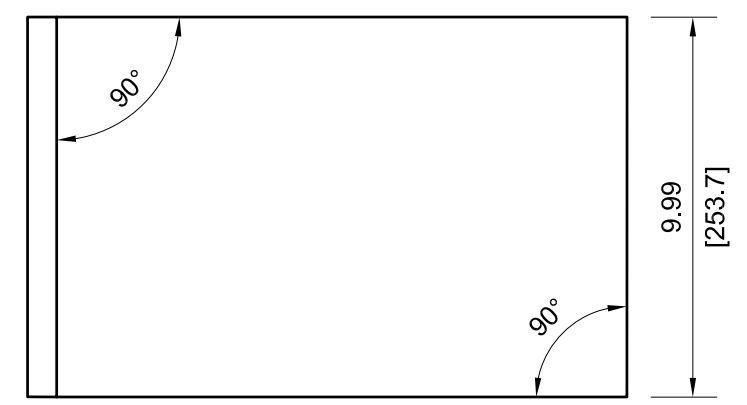
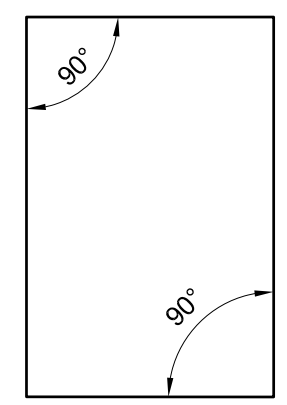
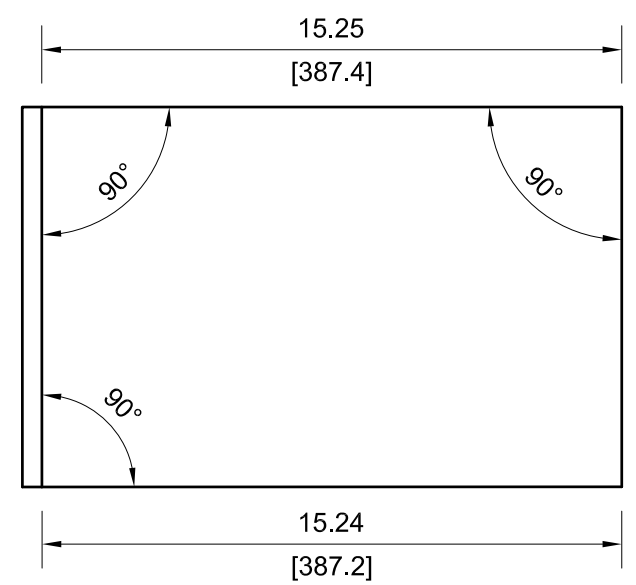
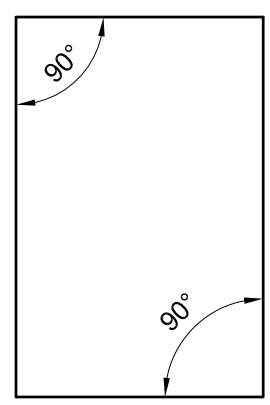
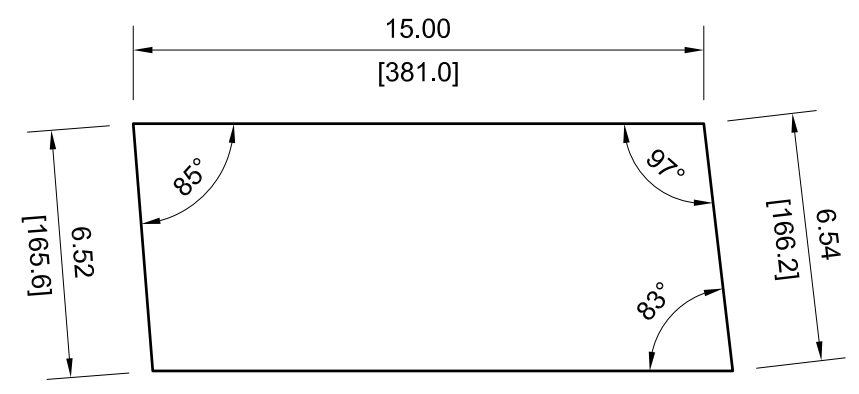

VIEW F7-78

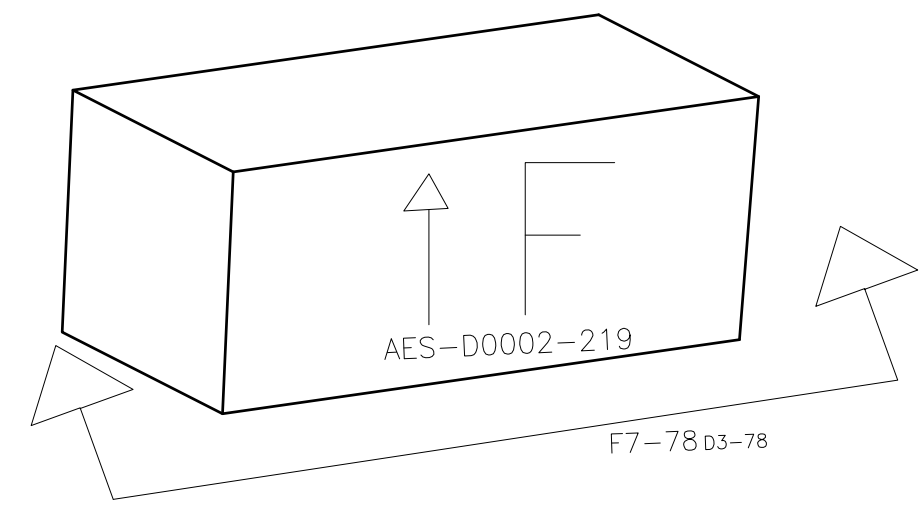
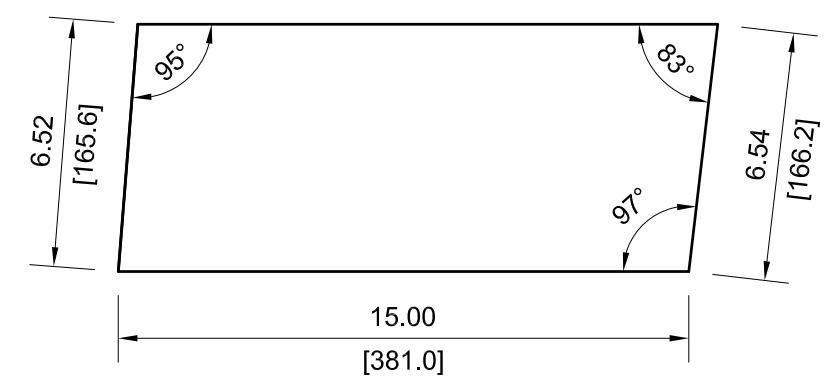

NOTE: ALL VIEWS TAKEN AS TRUE VIEWS PARALLEL TO SURFACE OF PART

	DRAWING NUMBER				AES-D0002
	SIZE	SCALE	SHEET	OF	REVISION
A3	NONE	78	167	F	

-221

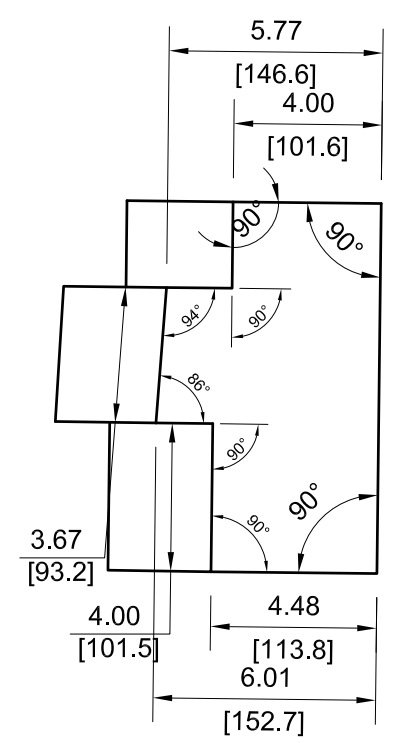
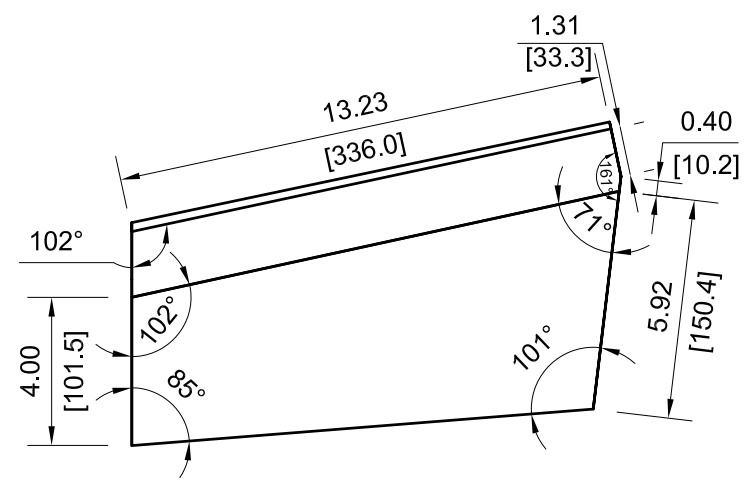

VIEW C3-79

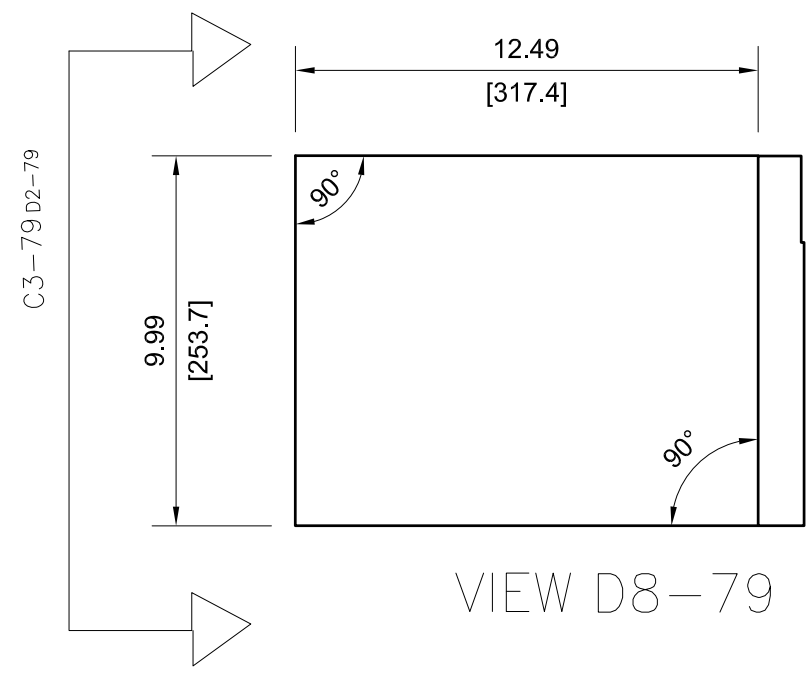

VIEW D8-79

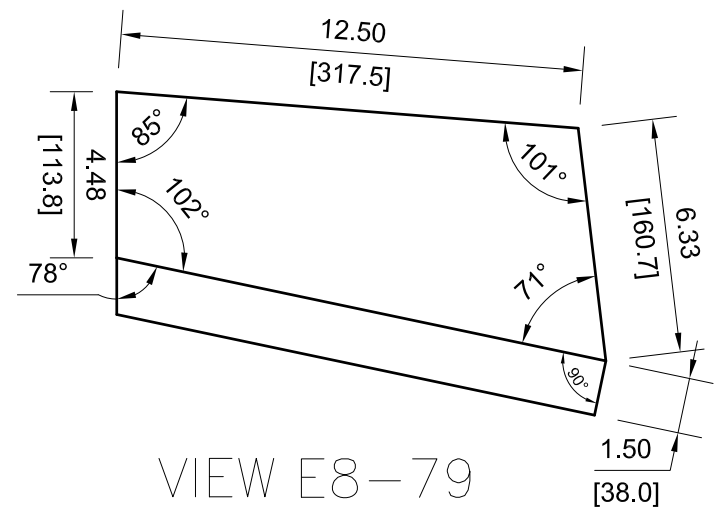

VIEW E8-79

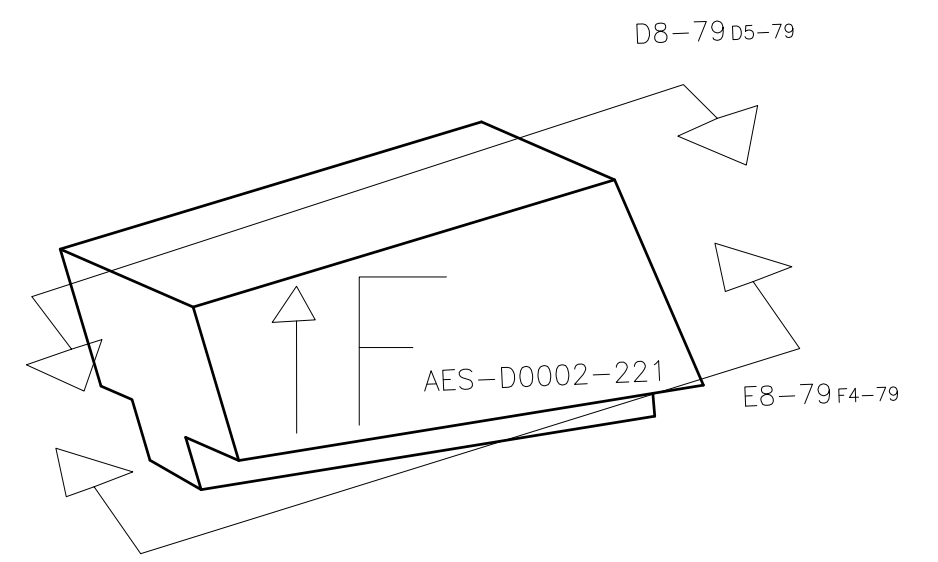

NOTE: ALL VIEWS TAKEN AS TRUE VIEWS PARALLEL TO SURFACE OF PART

	DRAWING NUMBER				
	AES-D0002				
SIZE	SCALE	SHEET	OF	REVISION	
A3	NONE	79	167	F	

-223

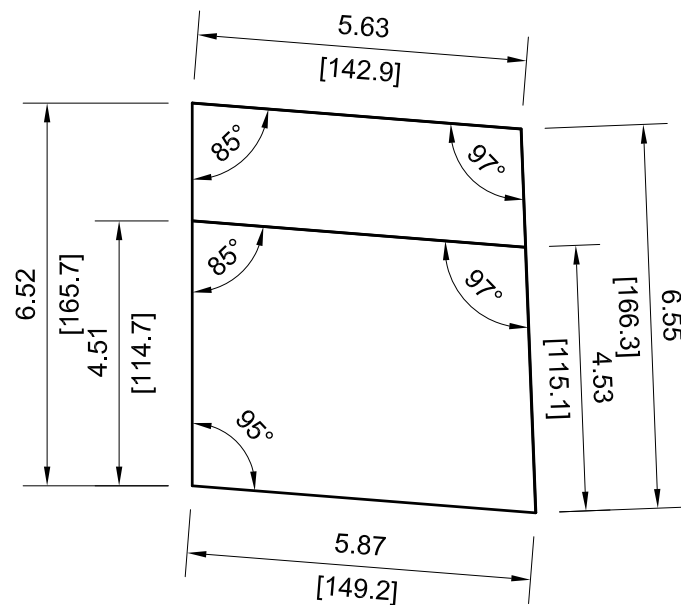
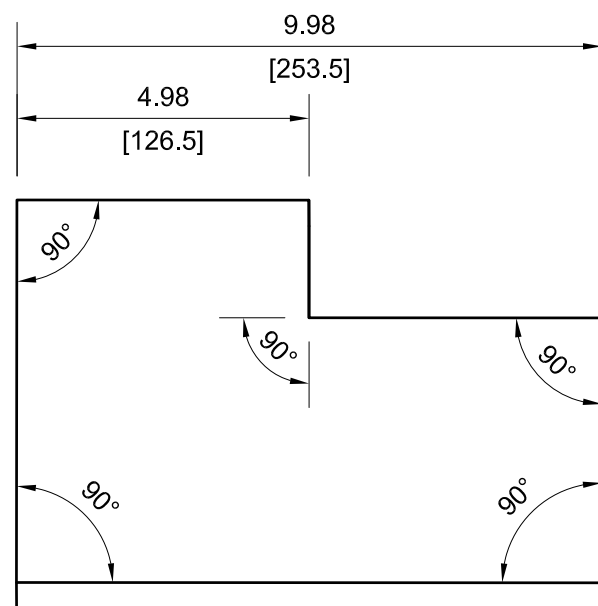
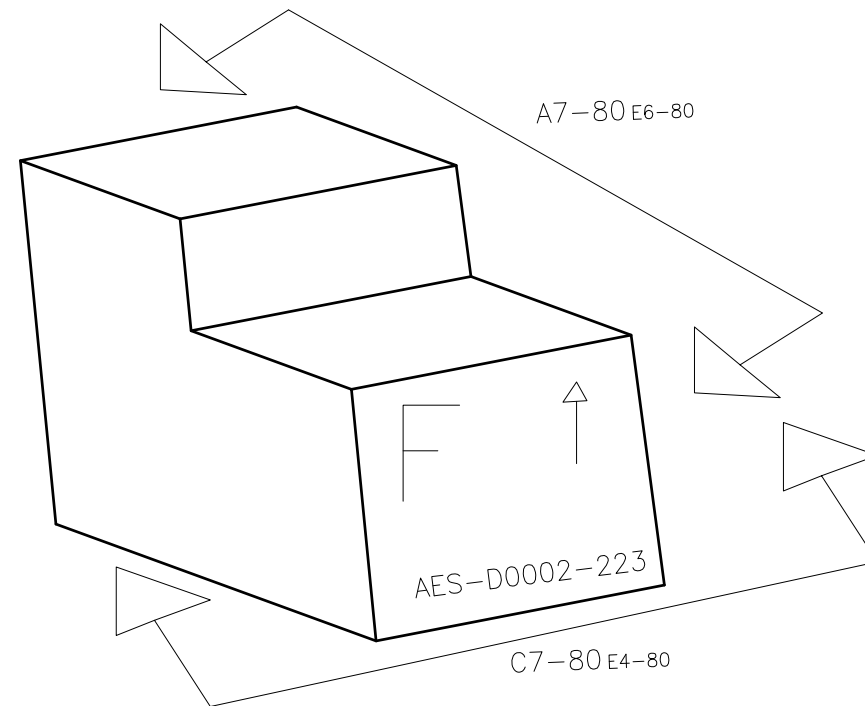
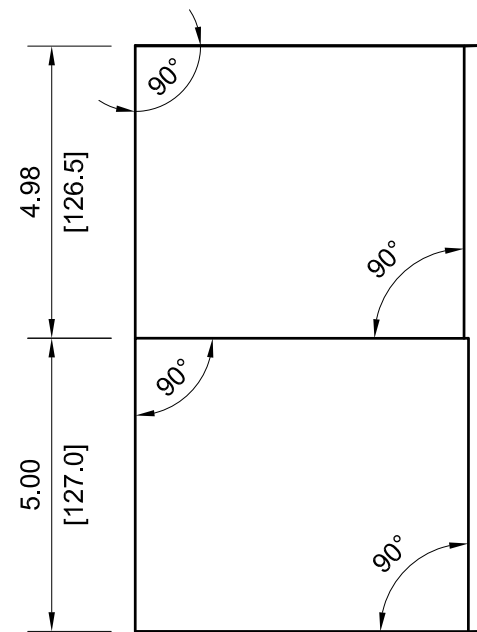

VIEW C7-80

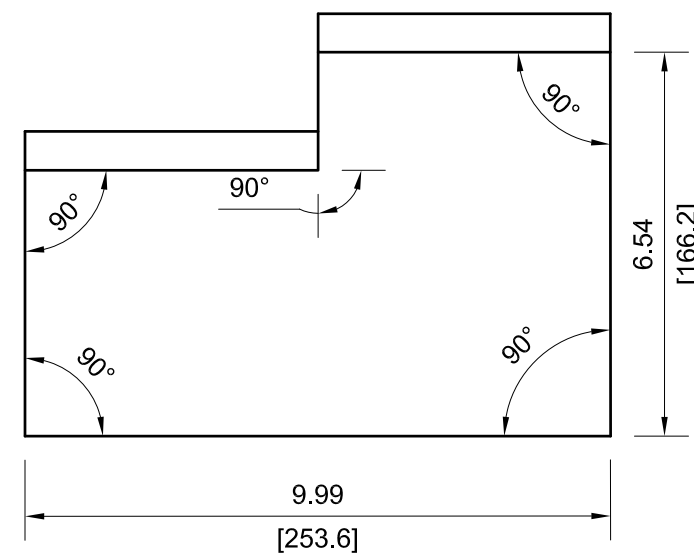

VIEW A7-80

NOTE: ALL VIEWS TAKEN AS TRUE VIEWS PARALLEL TO SURFACE OF PART

		DRAWING NUMBER			
		AES-D0002			
SIZE	SCALE	SHEET	OF	REVISION	
A3	NONE	80	167	F	

-225

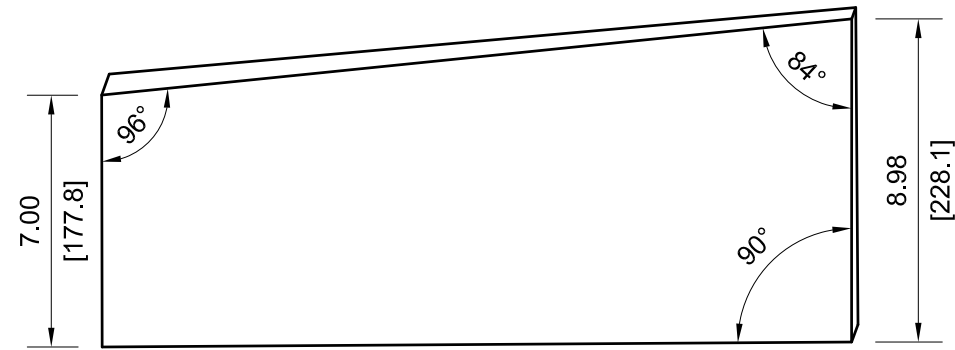

VIEW C5-81

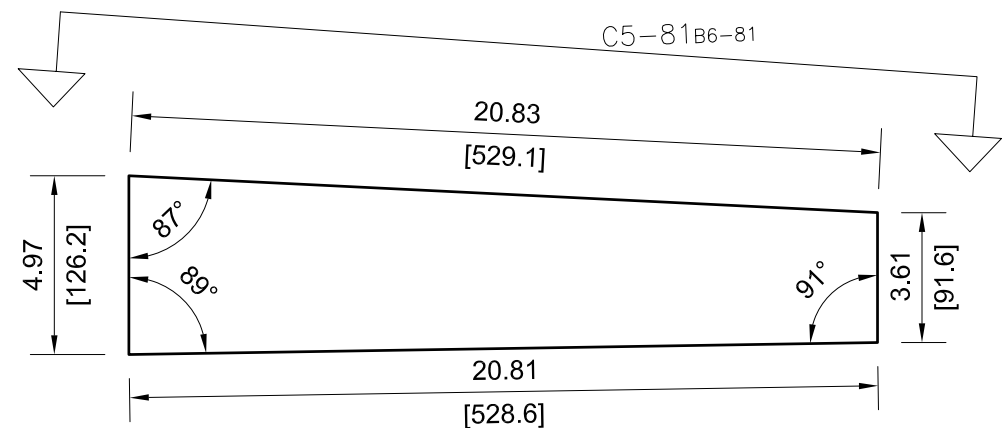
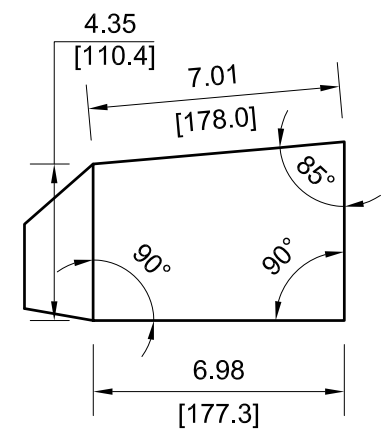

VIEW F6-81

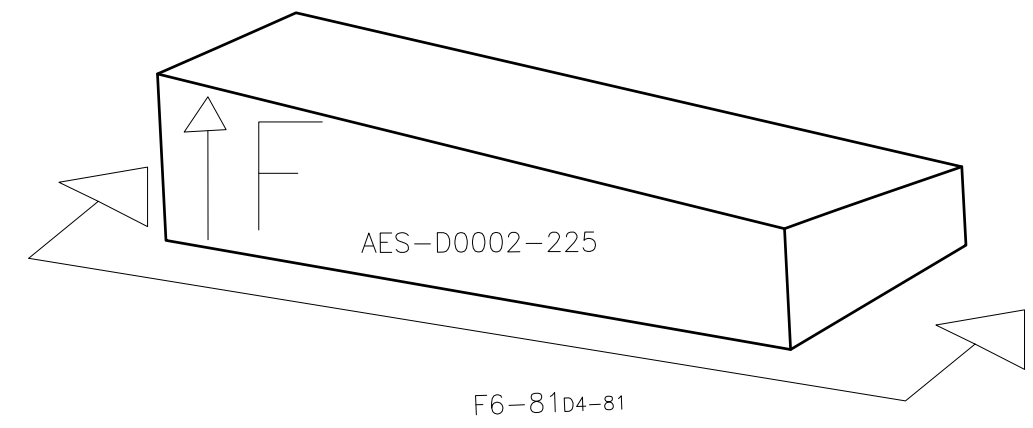
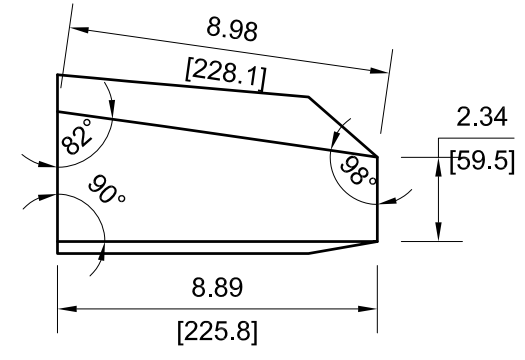

NOTE: ALL VIEWS TAKEN AS TRUE VIEWS PARALLEL TO SURFACE OF PART

		DRAWING NUMBER			
		AES-D0002			
SIZE	SCALE	SHEET	OF	REVISION	
A3	NONE	81	167	F	

-227

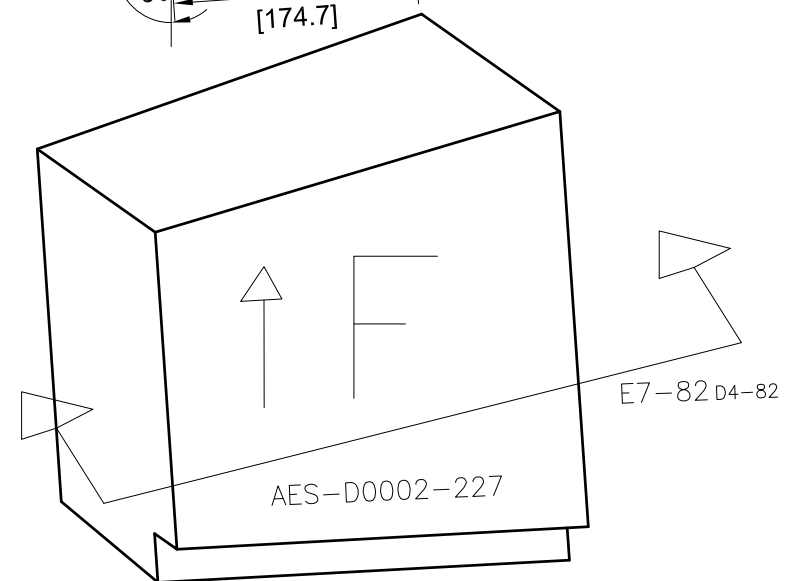
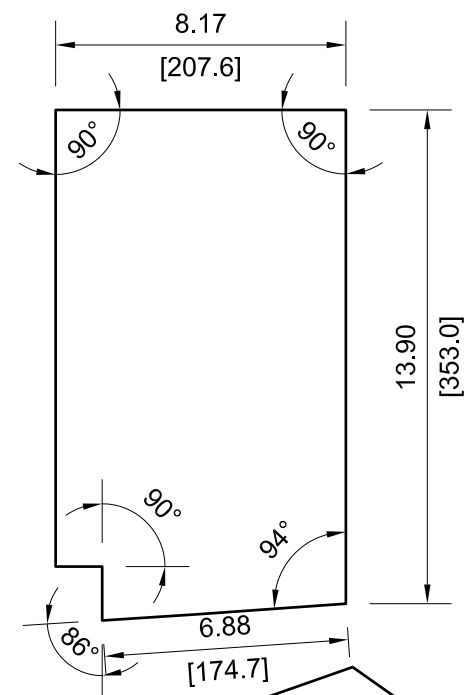
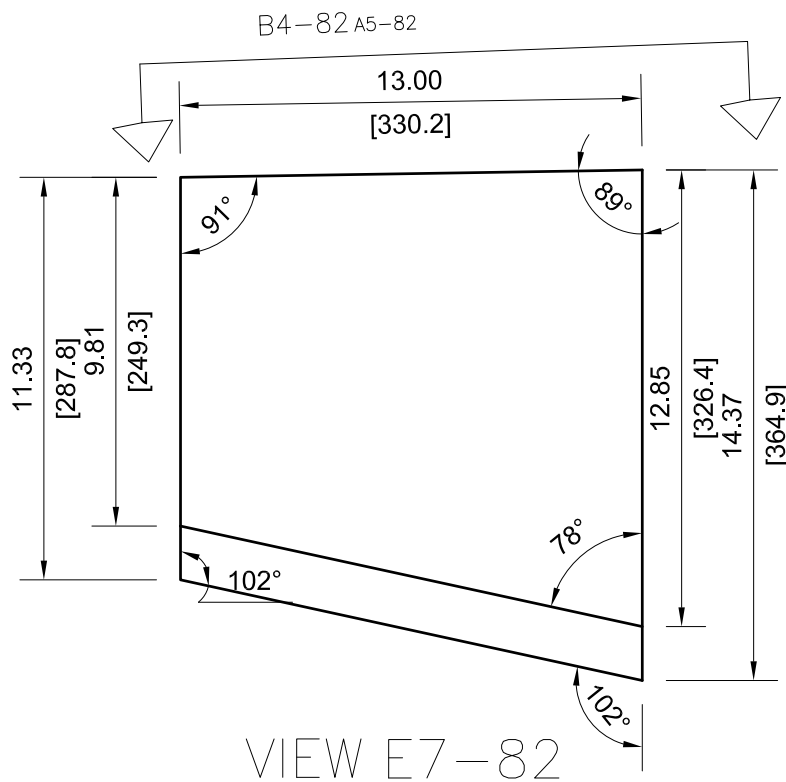
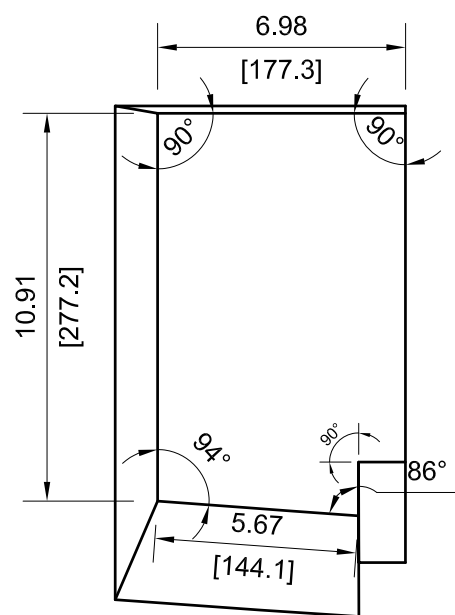
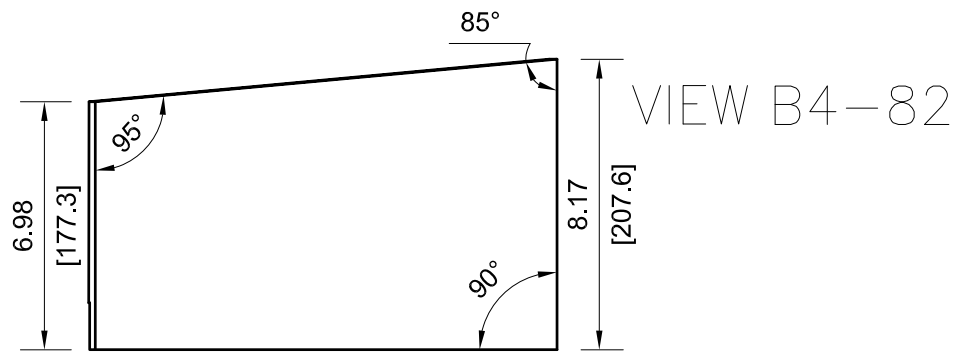

NOTE: ALL VIEWS TAKEN AS TRUE VIEWS PARALLEL TO SURFACE OF PART

		DRAWING NUMBER			
		AES-D0002			
SIZE	SCALE	SHEET	OF	REVISION	
A3	NONE	82	167	F	

-229

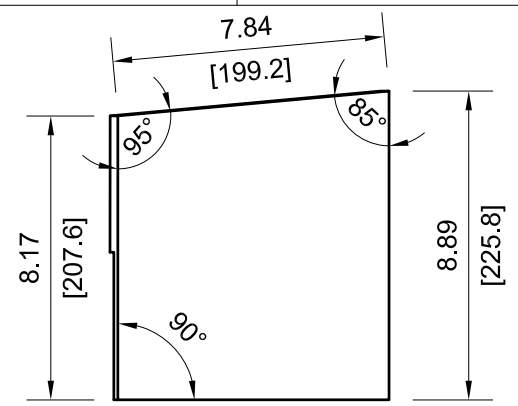

VIEW B4-83

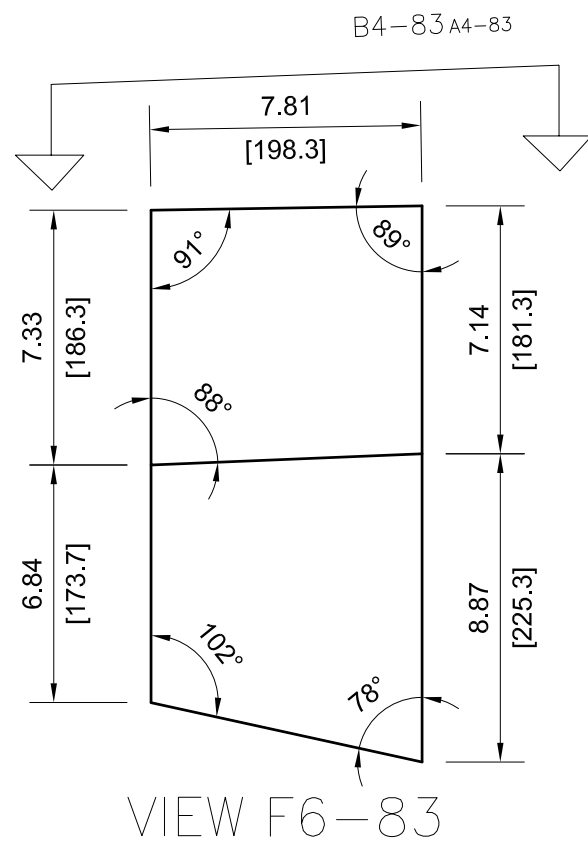
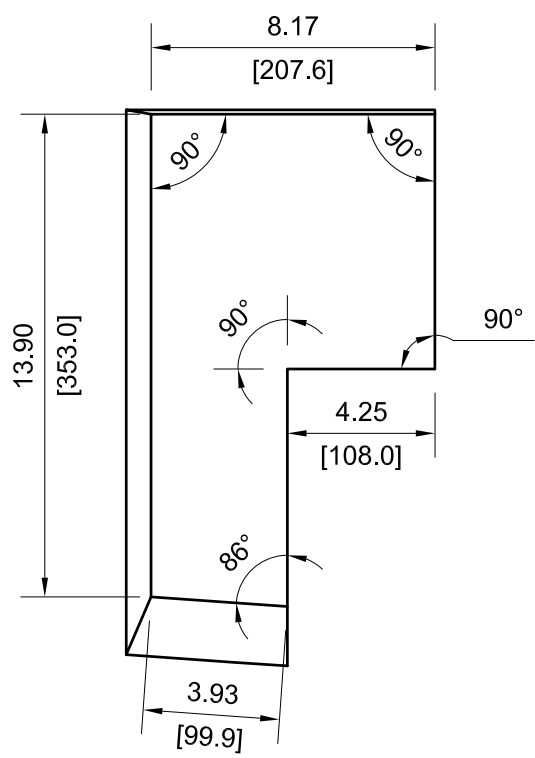

VIEW F6-83

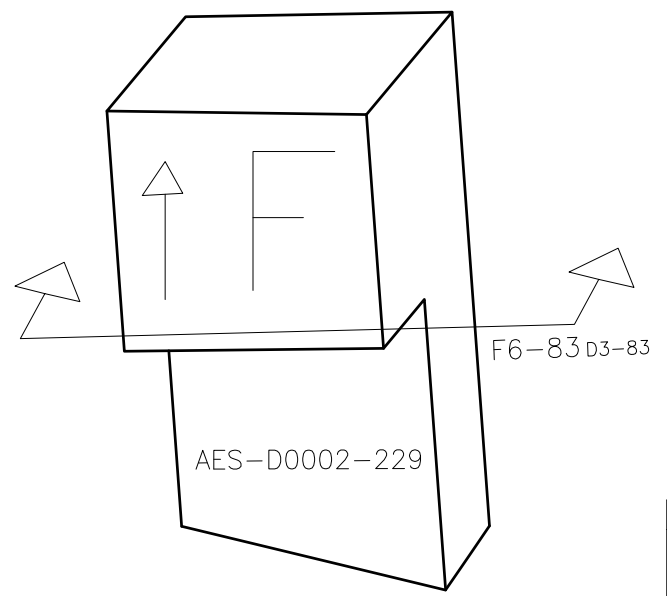
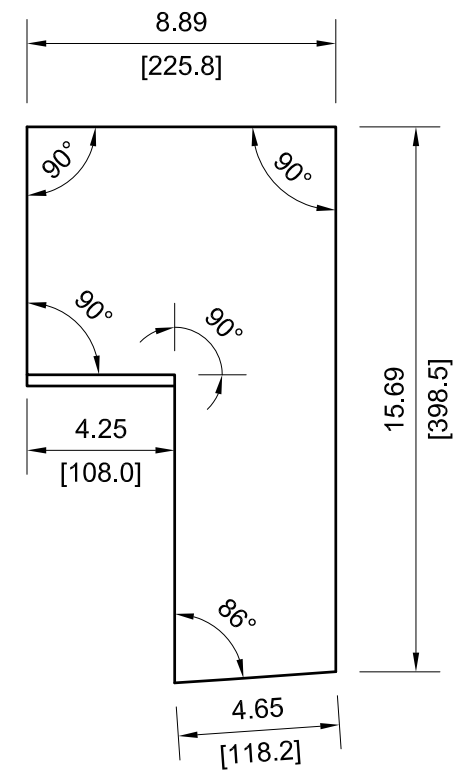

NOTE: ALL VIEWS TAKEN AS TRUE VIEWS PARALLEL TO SURFACE OF PART

		DRAWING NUMBER			
		AES-D0002			
SIZE	SCALE	SHEET	OF	REVISION	
A3	NONE	83	167	F	

-231

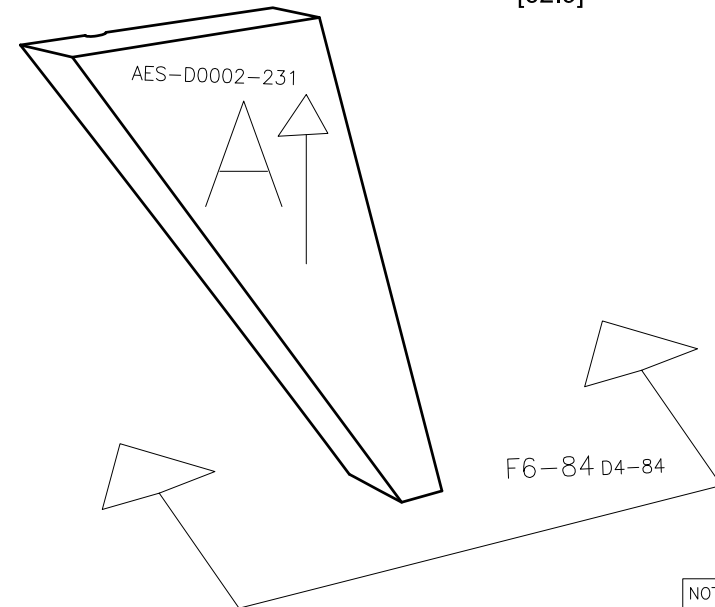
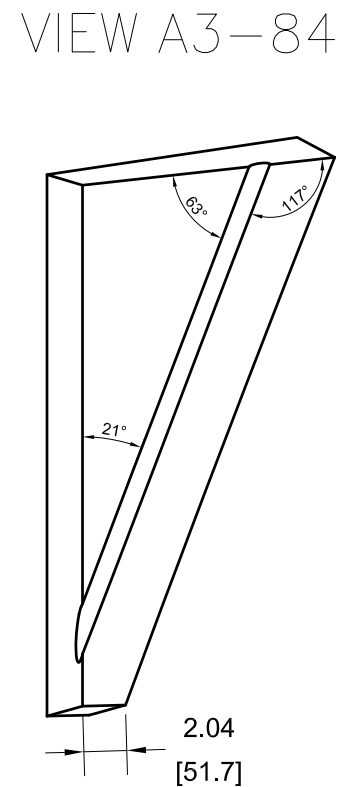
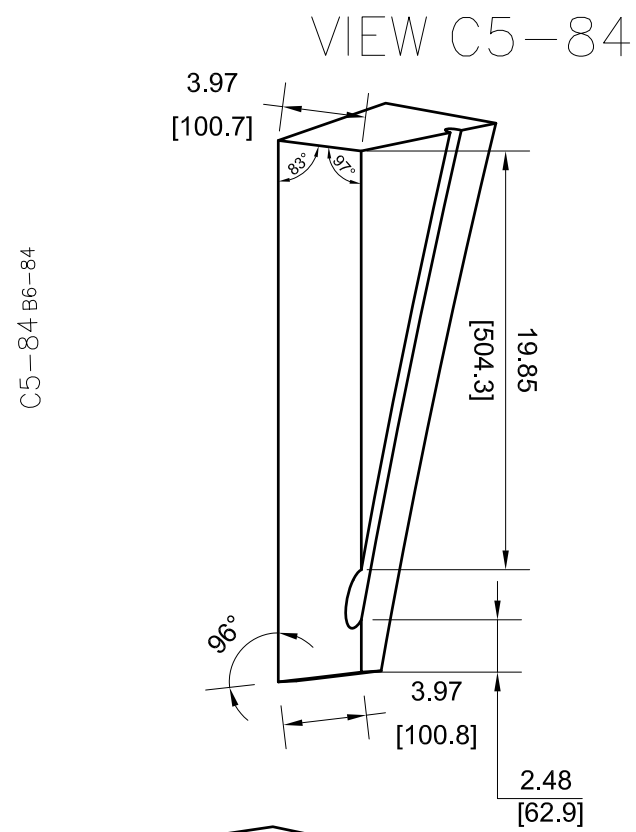
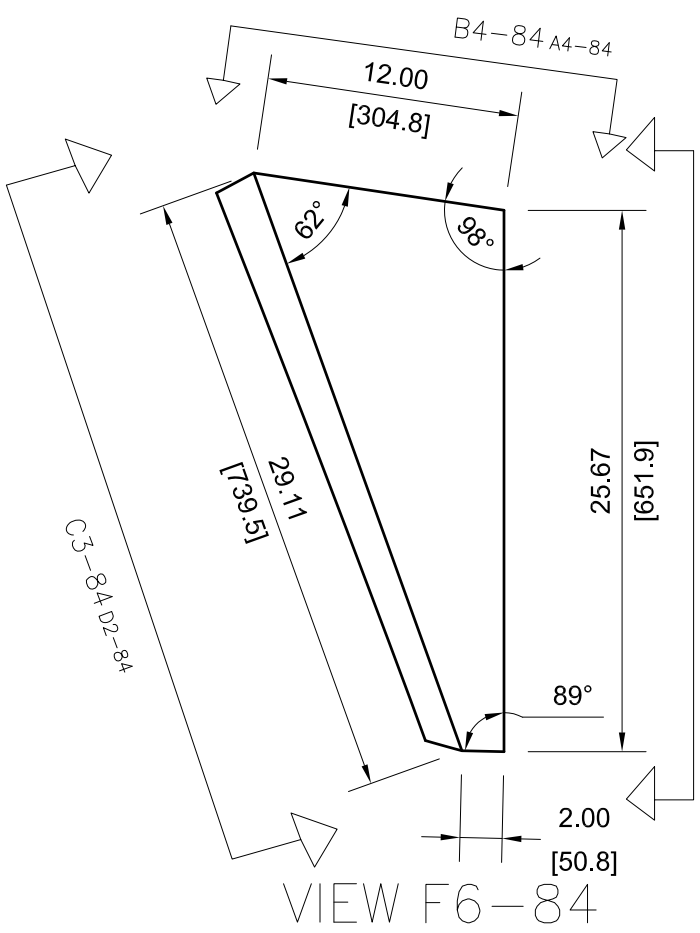
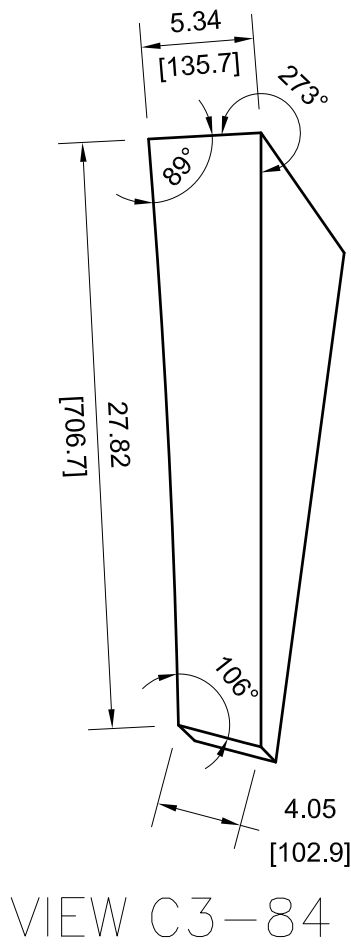
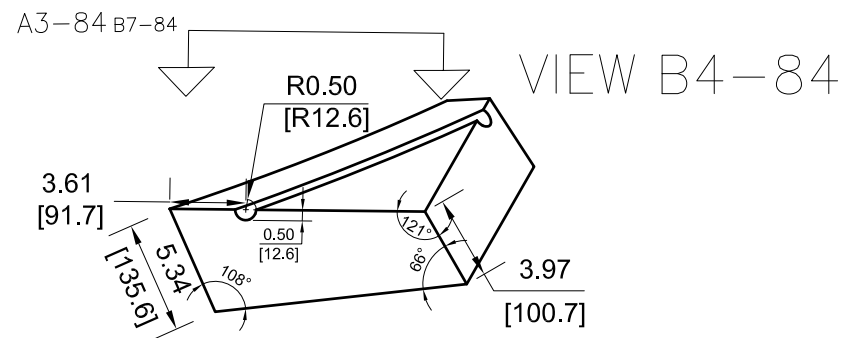

NOTE: ALL VIEWS TAKEN AS TRUE VIEWS PARALLEL TO SURFACE OF PART

		DRAWING NUMBER			
		AES-D0002			
SIZE	SCALE	SHEET	OF	REVISION	
A3	NONE	84	167	F	

-233

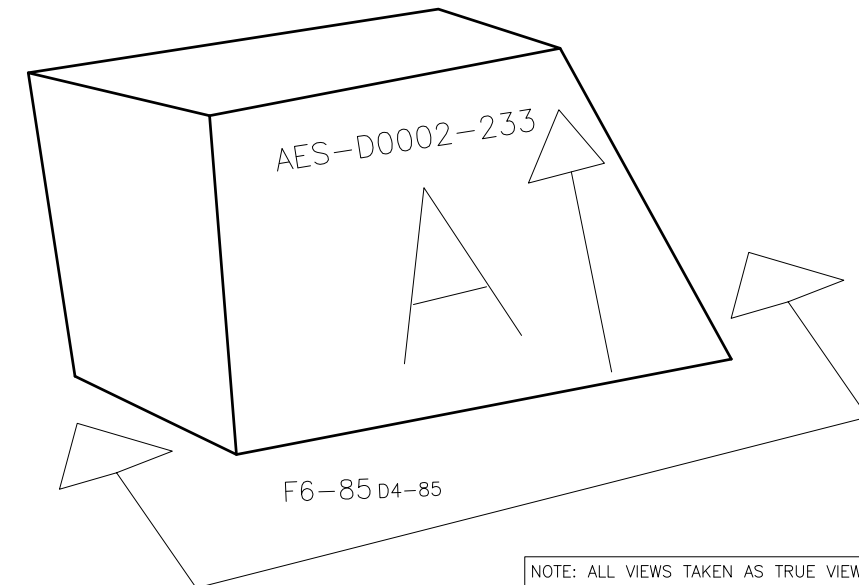
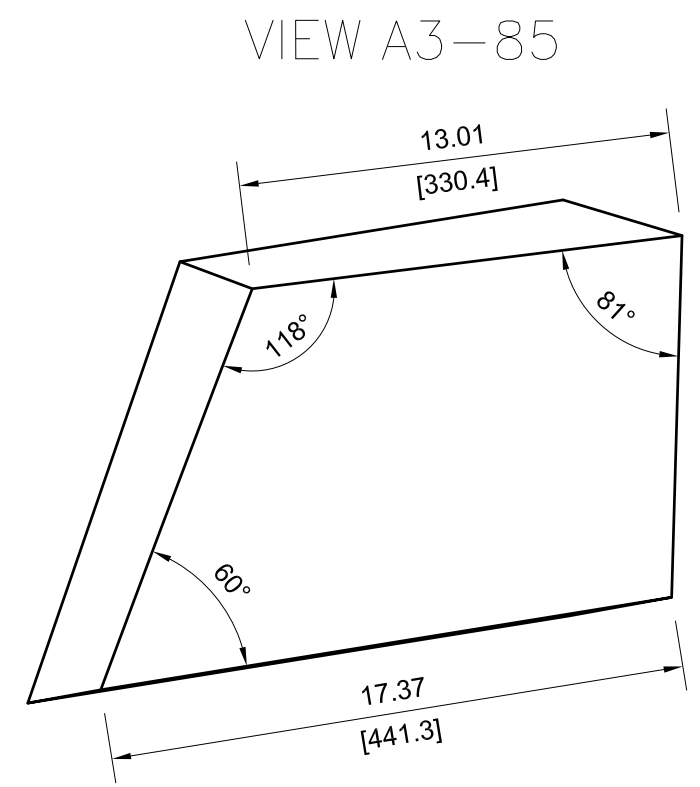
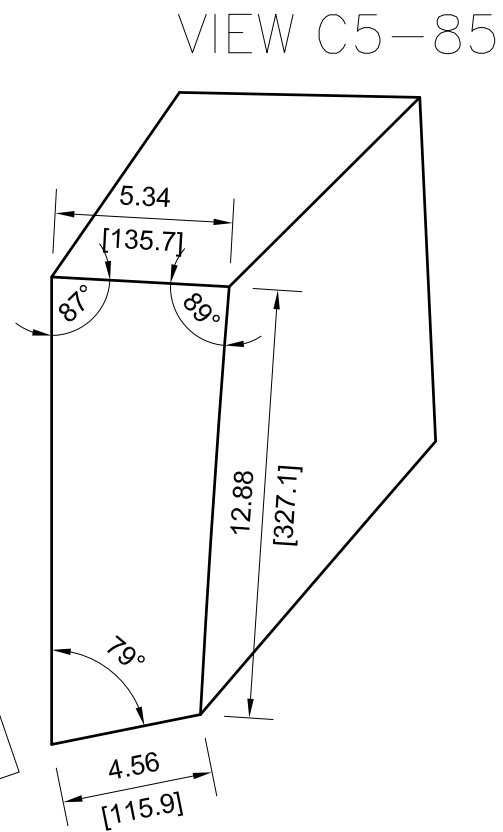
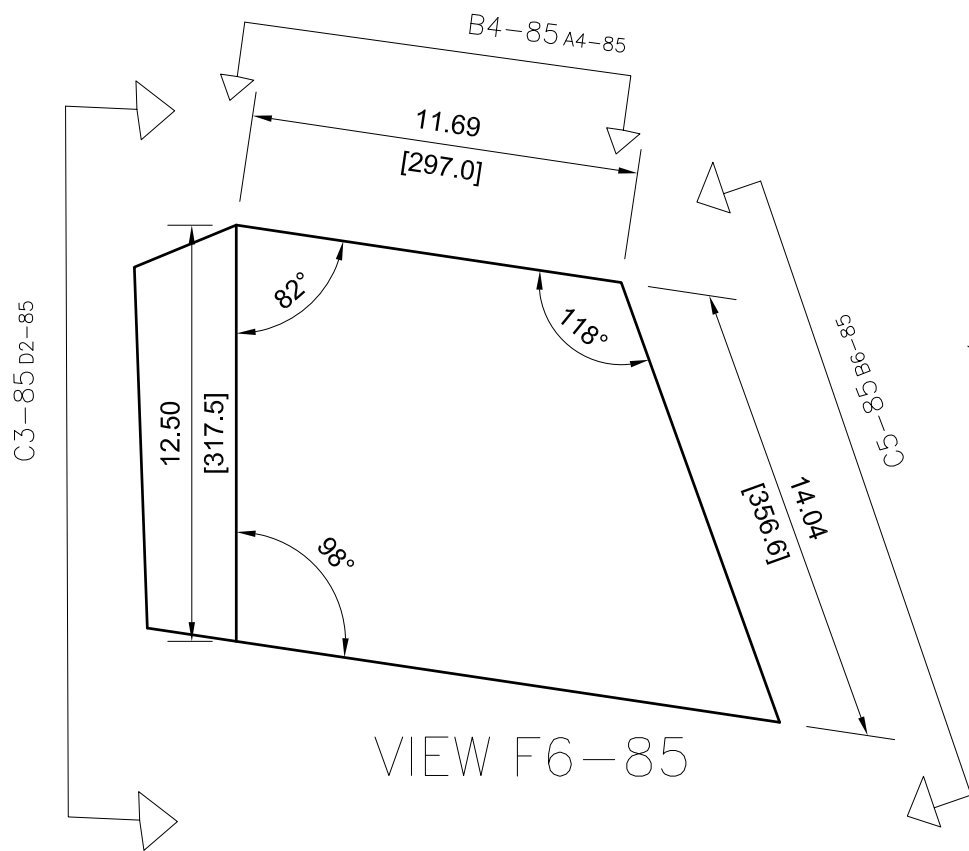
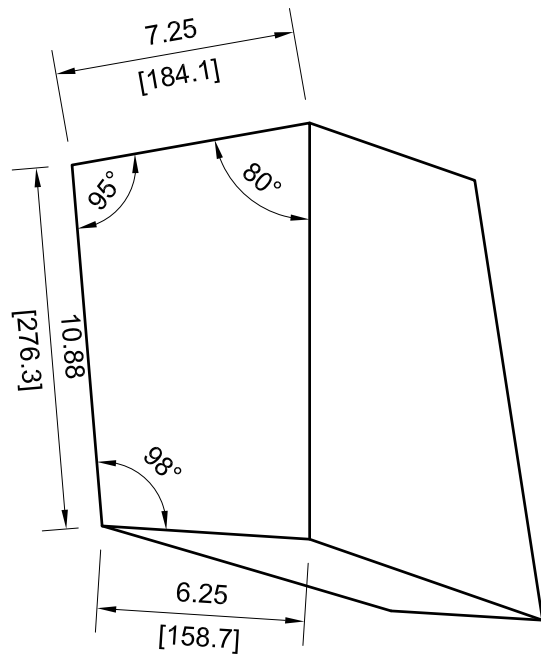
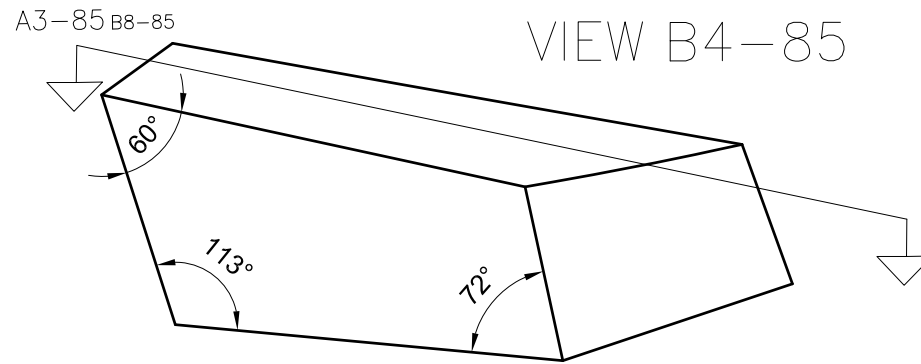

NOTE: ALL VIEWS TAKEN AS TRUE VIEWS PARALLEL TO SURFACE OF PART

		DRAWING NUMBER			
		AES-D0002			
SIZE	SCALE	SHEET	OF	REVISION	
A3	NONE	85	167	F	

-235

A3-86 B8-86

A5-86 B6-86

A2-86 D1-86

VIEW D6-86

VIEW A5-86

VIEW A3-86

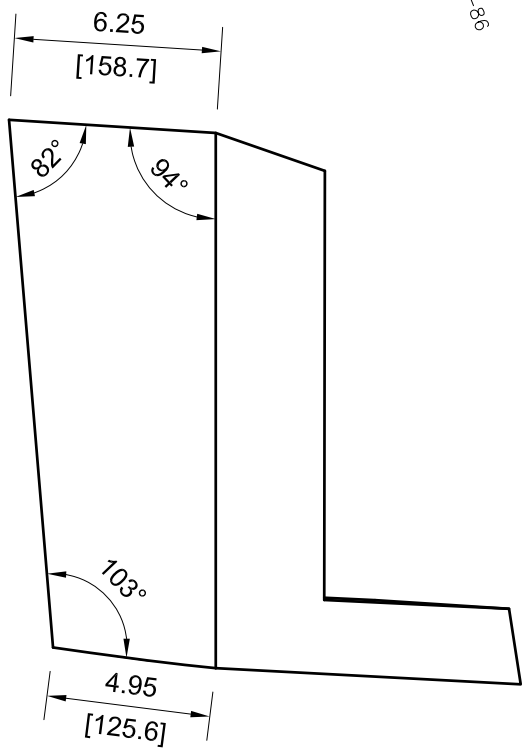

VIEW A2-86

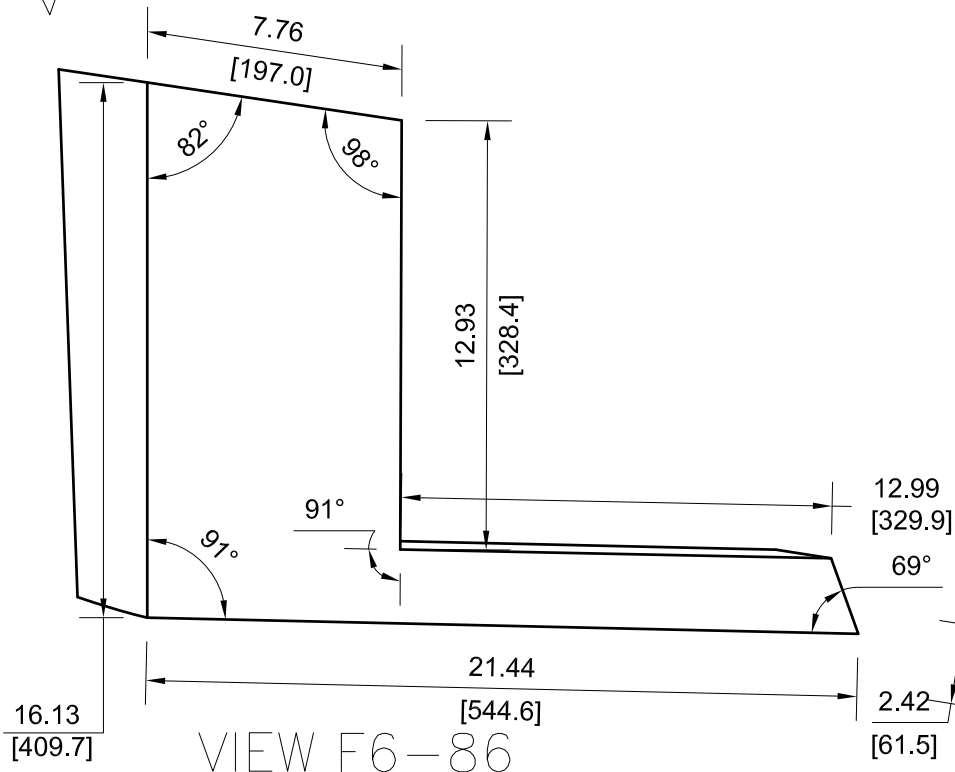

VIEW F6-86

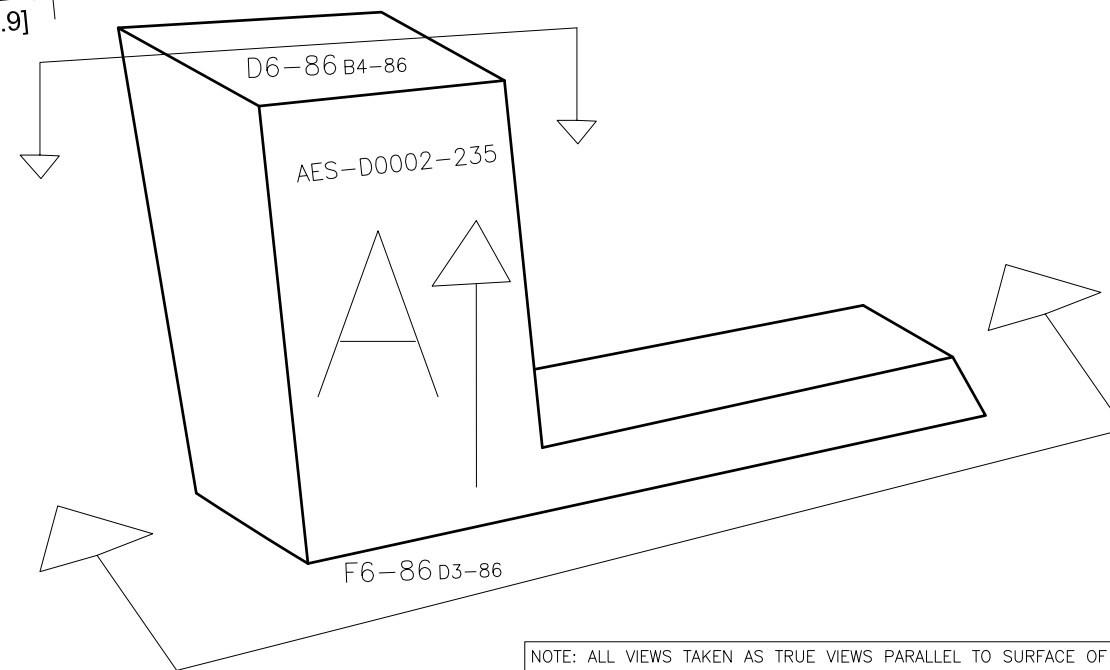
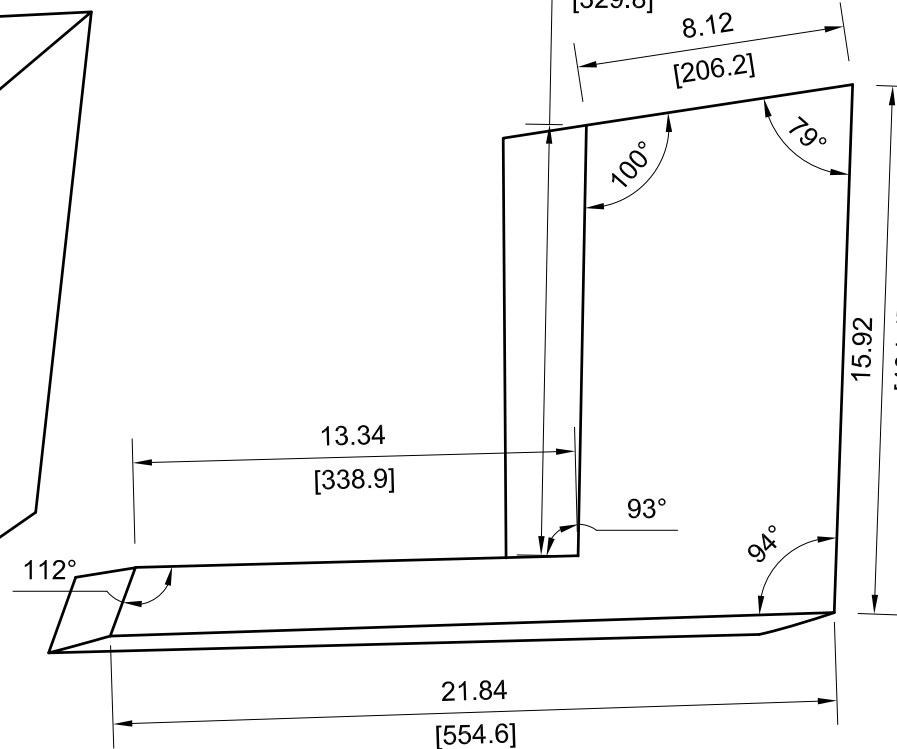
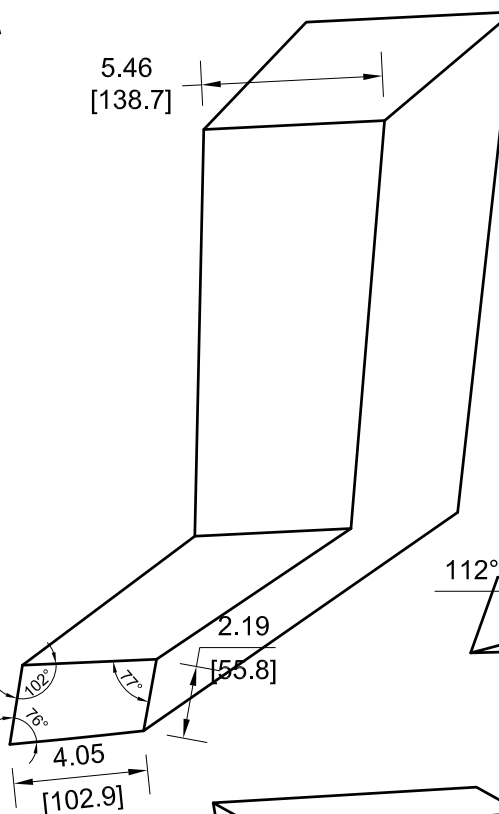

NOTE: ALL VIEWS TAKEN AS TRUE VIEWS PARALLEL TO SURFACE OF PART



DRAWING NUMBER				
AES-D0002				
SIZE	SCALE	SHEET	OF	REVISION
A3	NONE	86	167	F

-237

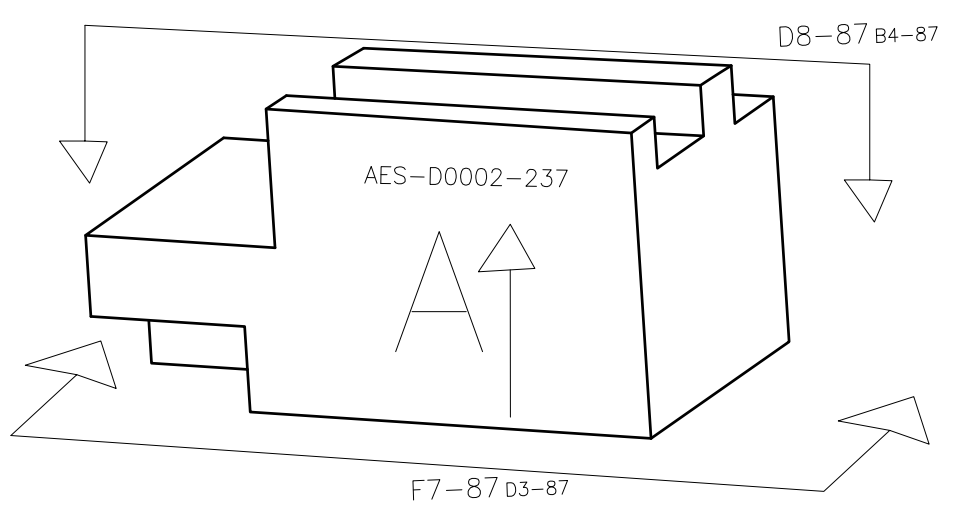
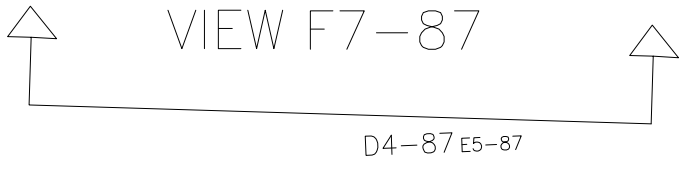
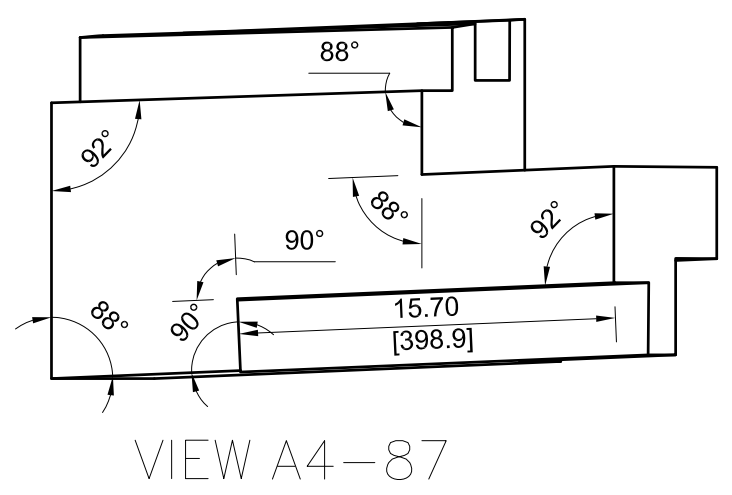
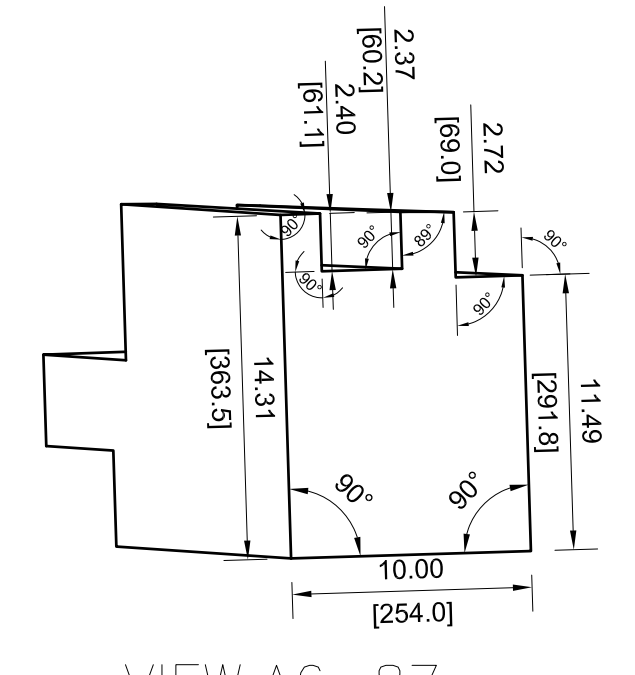
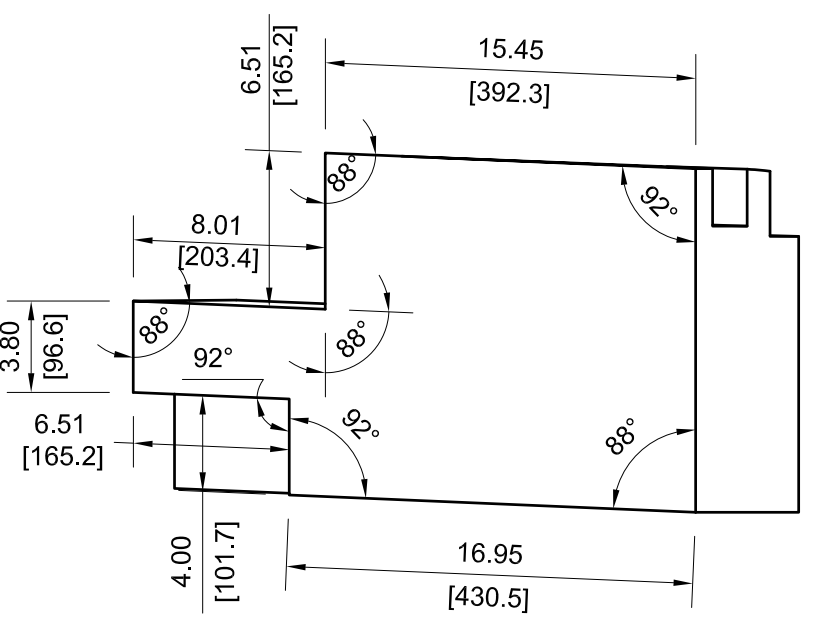
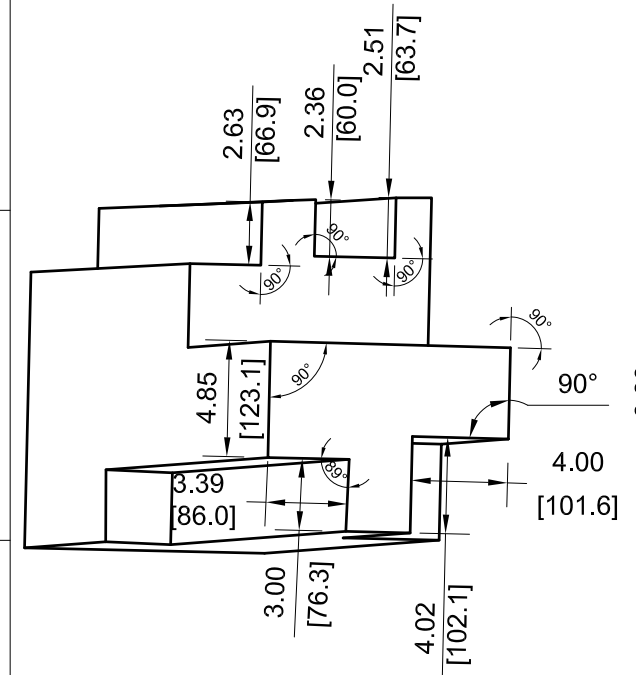
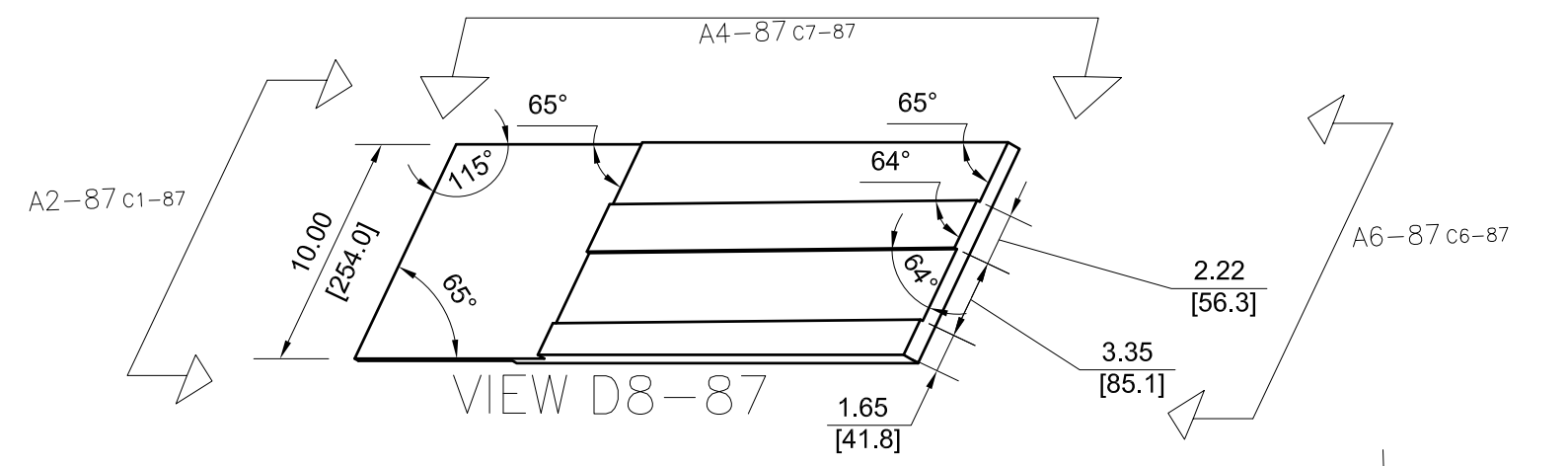

VIEW A2-87

VIEW F7-87

VIEW A6-87

VIEW A4-87

VIEW D4-87

NOTE: ALL VIEWS TAKEN AS TRUE VIEWS PARALLEL TO SURFACE OF PART

		DRAWING NUMBER			
		AES-D0002			
SIZE	SCALE	SHEET	OF	REVISION	
A3	NONE	87	167	F	

-239

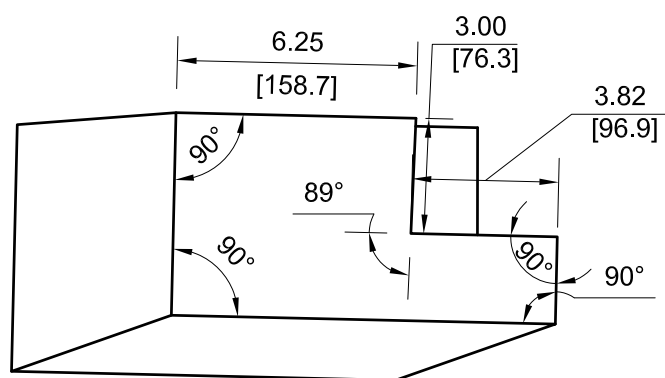
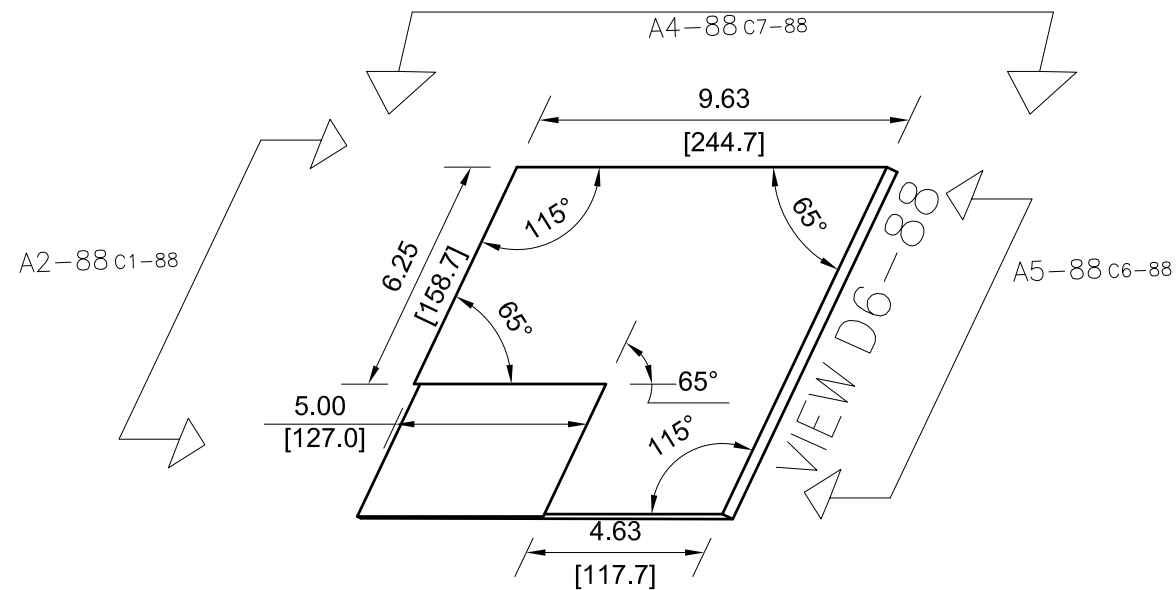

VIEW A2-88

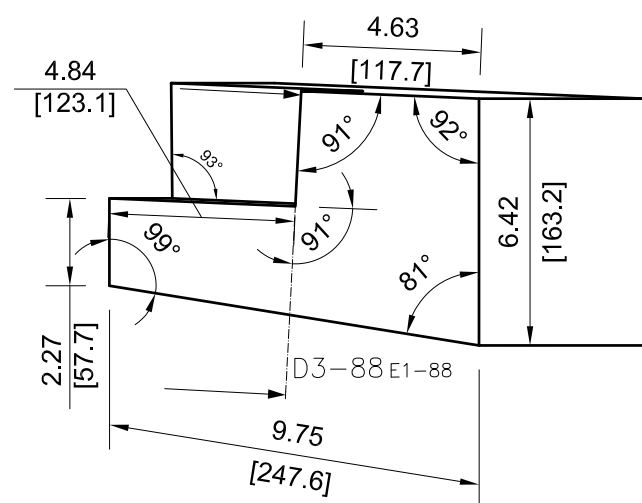

VIEW E7-88

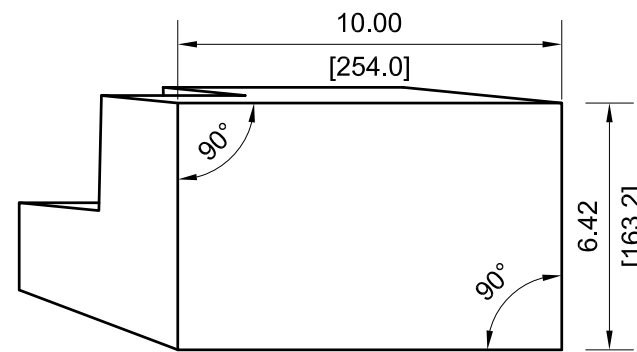

VIEW A5-88

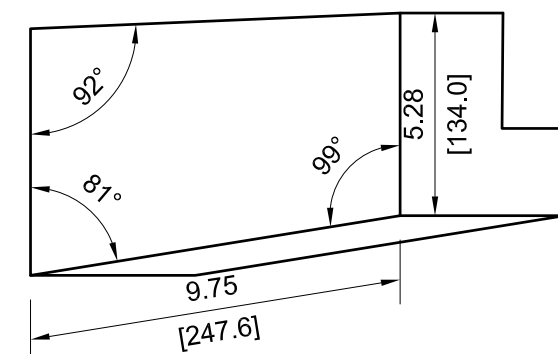

VIEW A4-88

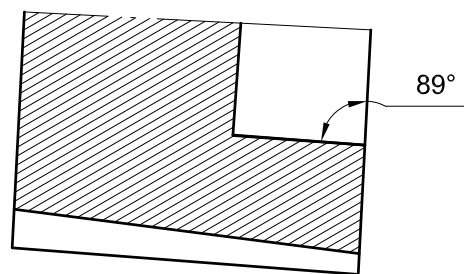

SECTION VIEW D3-88

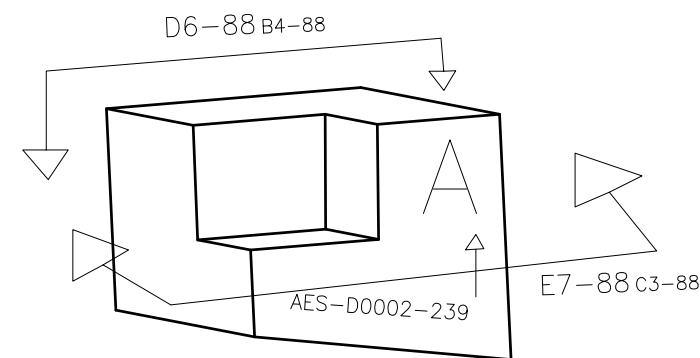

NOTE: ALL VIEWS TAKEN AS TRUE VIEWS PARALLEL TO SURFACE OF PART



DRAWING NUMBER				
AES-D0002				
SIZE	SCALE	SHEET	OF	REVISION
A3	NONE	88	167	F

-241

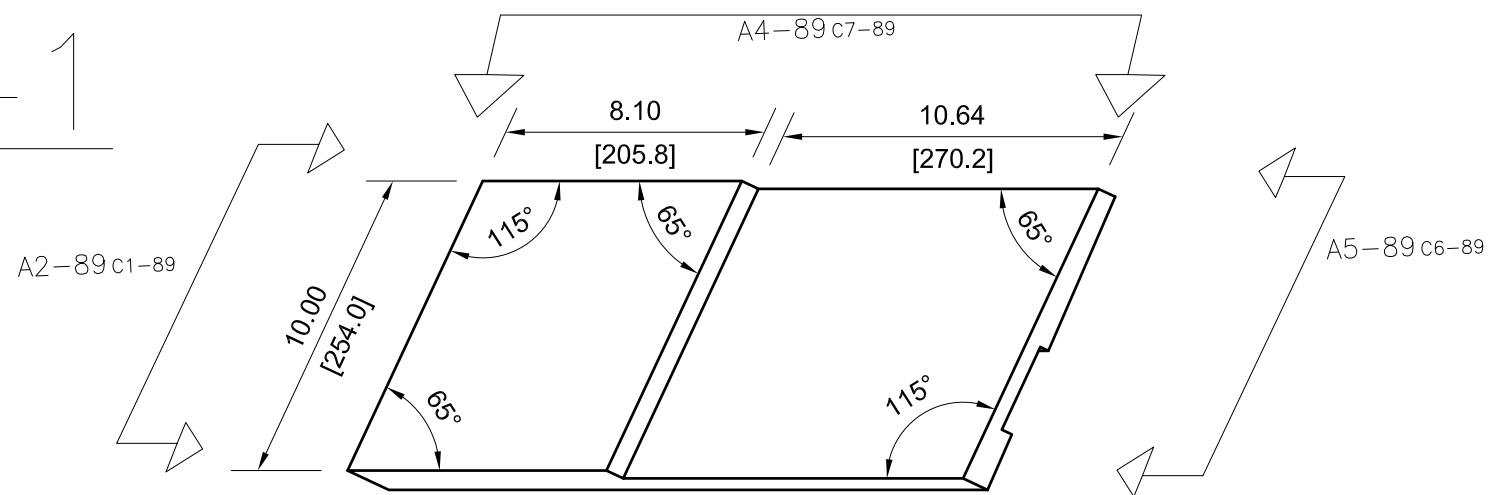

VIEW E6-89

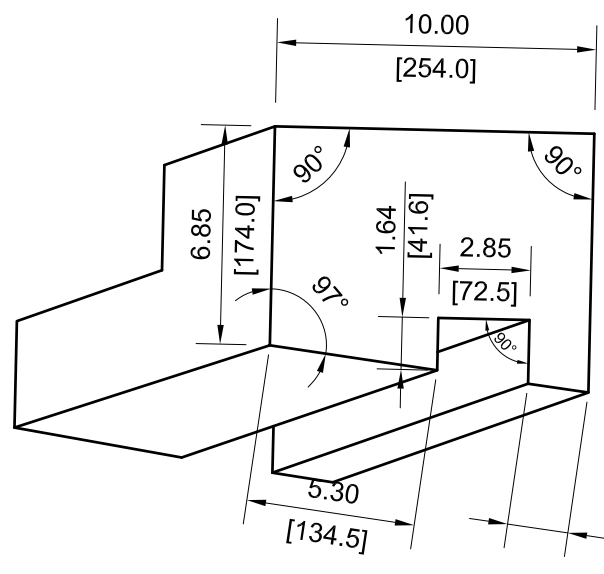

VIEW A2-89

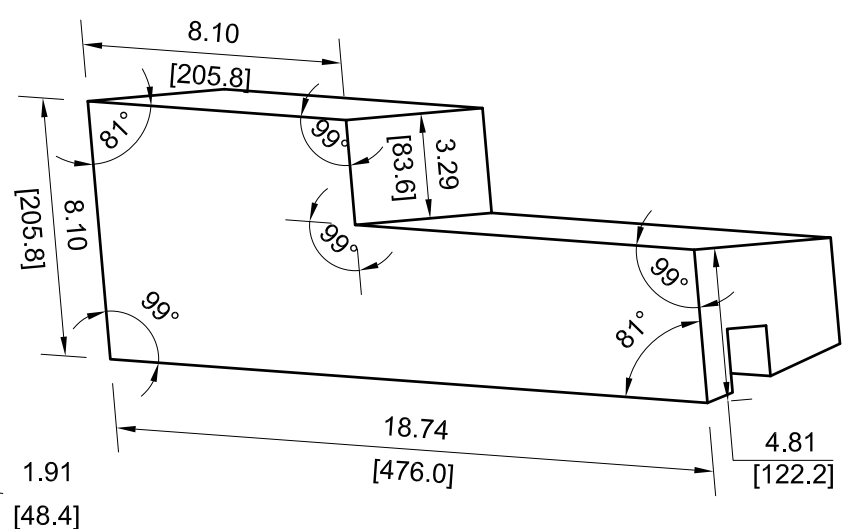

VIEW F5-89

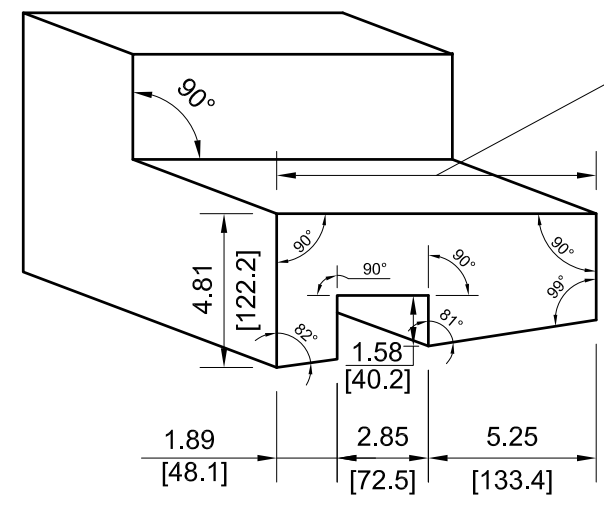

VIEW A5-89

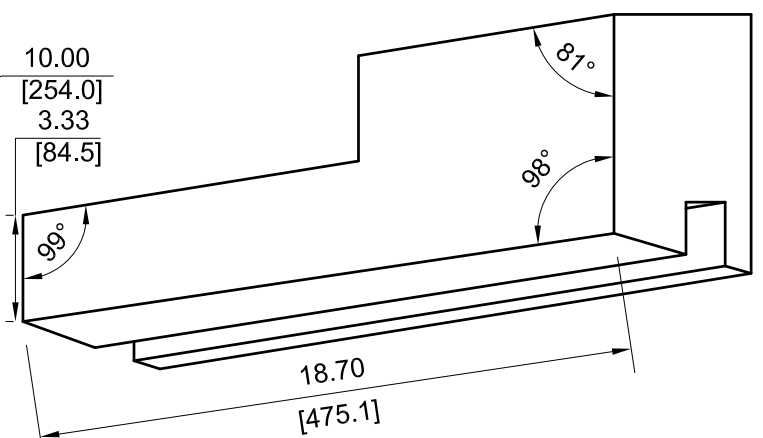

VIEW A4-89

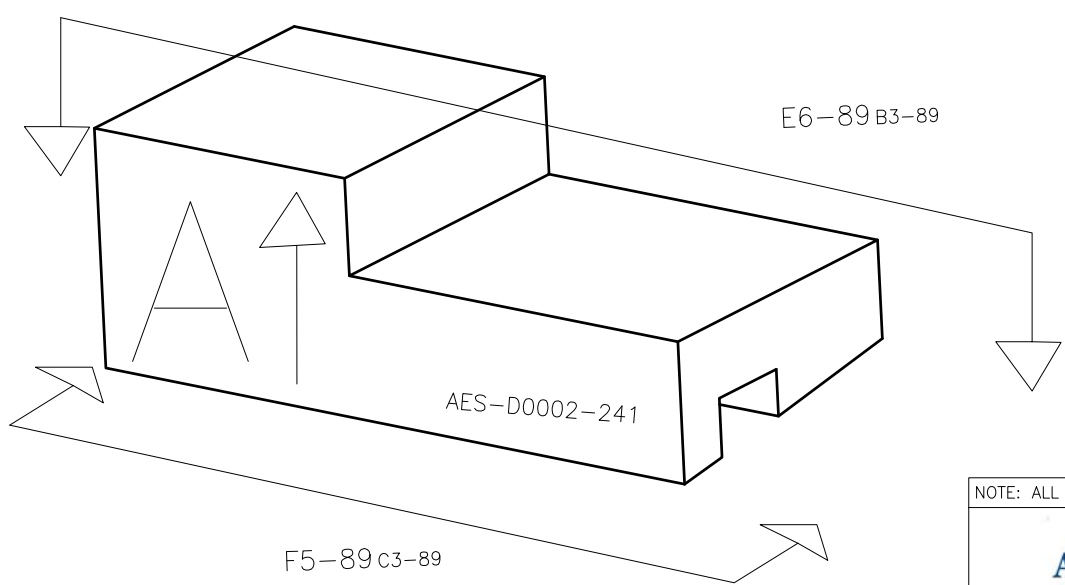

NOTE: ALL VIEWS TAKEN AS TRUE VIEWS PARALLEL TO SURFACE OF PART

DRAWING NUMBER				
AES-D0002				
SIZE	SCALE	SHEET	OF	REVISION
A3	NONE	89	167	F

-243

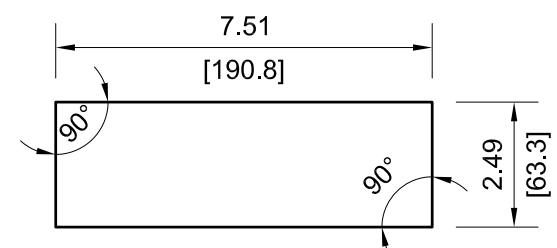
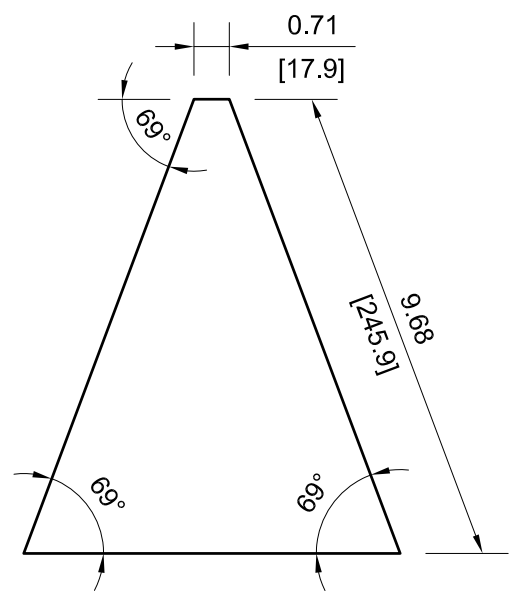

VIEW E6-90

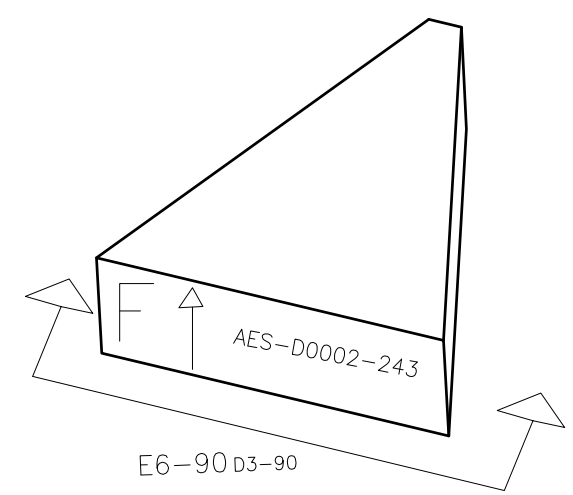
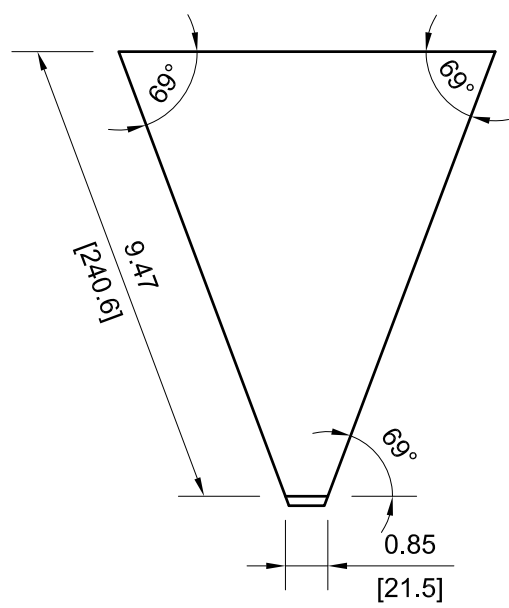
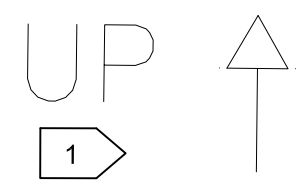

NOTE: ALL VIEWS TAKEN AS TRUE VIEWS PARALLEL TO SURFACE OF PART

	DRAWING NUMBER				
	AES-D0002				
SIZE	SCALE	SHEET	OF	REVISION	
A3	NONE	90	167	F	

-247

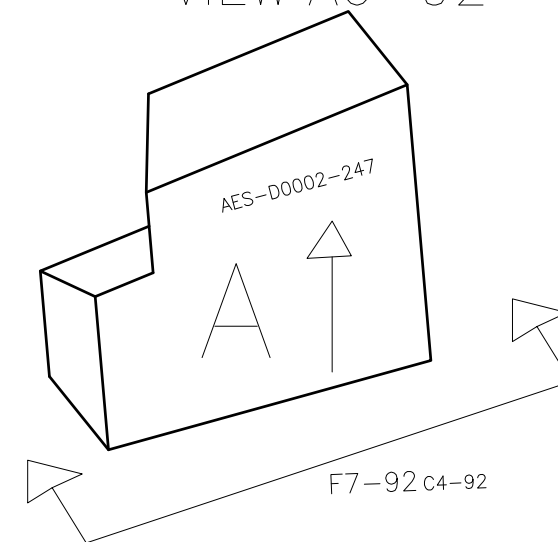
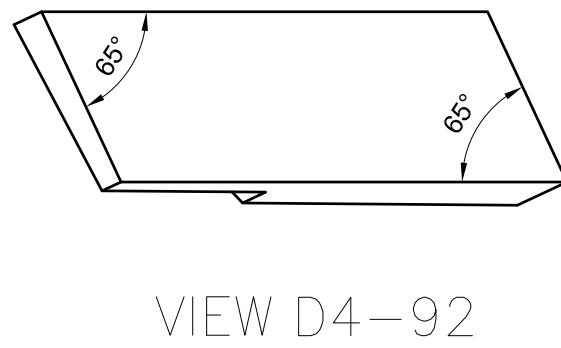
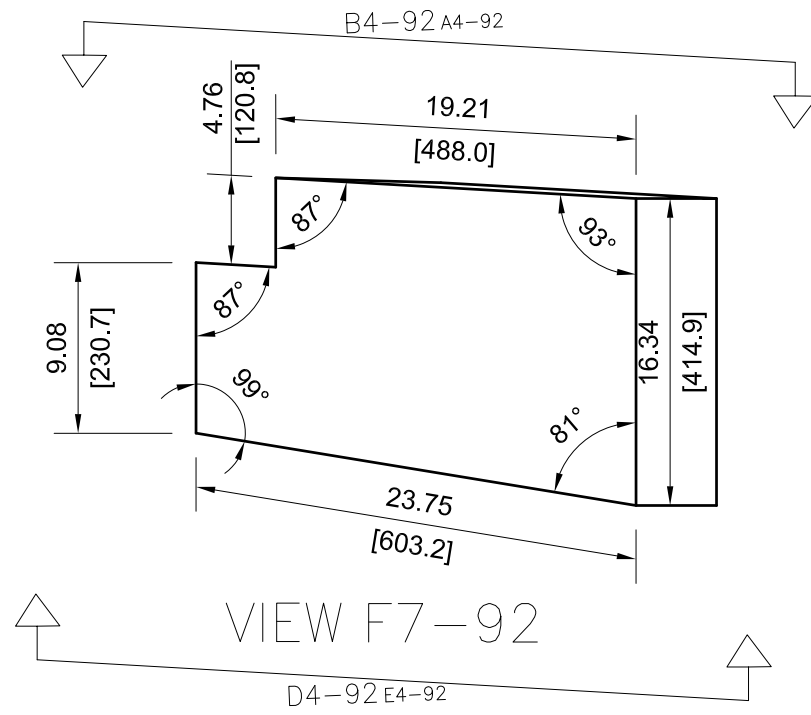
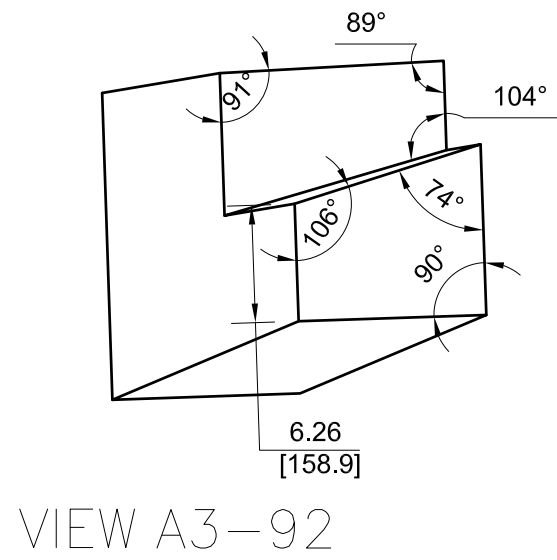
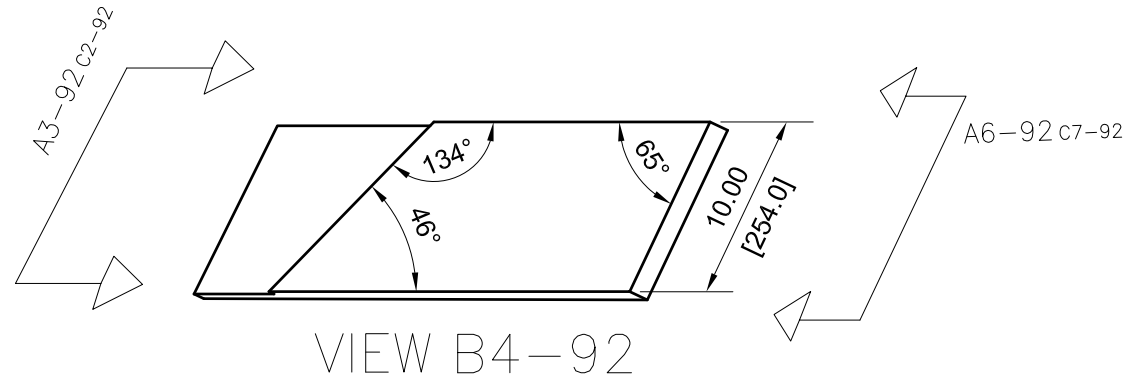

NOTE: ALL VIEWS TAKEN AS TRUE VIEWS PARALLEL TO SURFACE OF PART

		DRAWING NUMBER			
		AES-D0002			
SIZE	SCALE	SHEET	OF	REVISION	
A3	NONE	92	167	F	

-249

VIEW B4-93

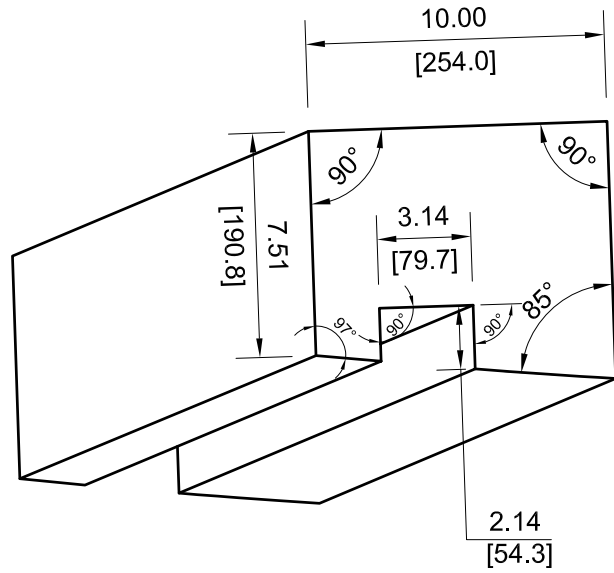
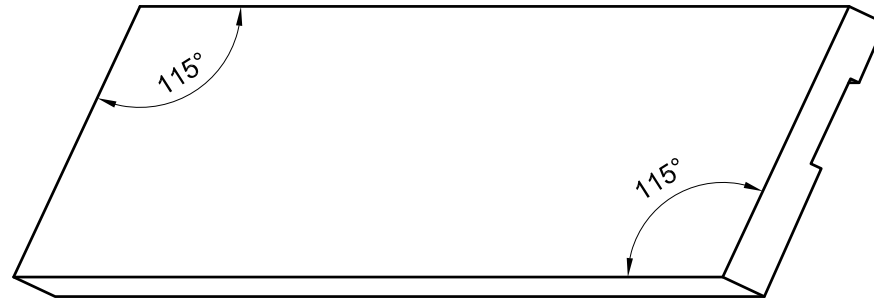

VIEW C3-93

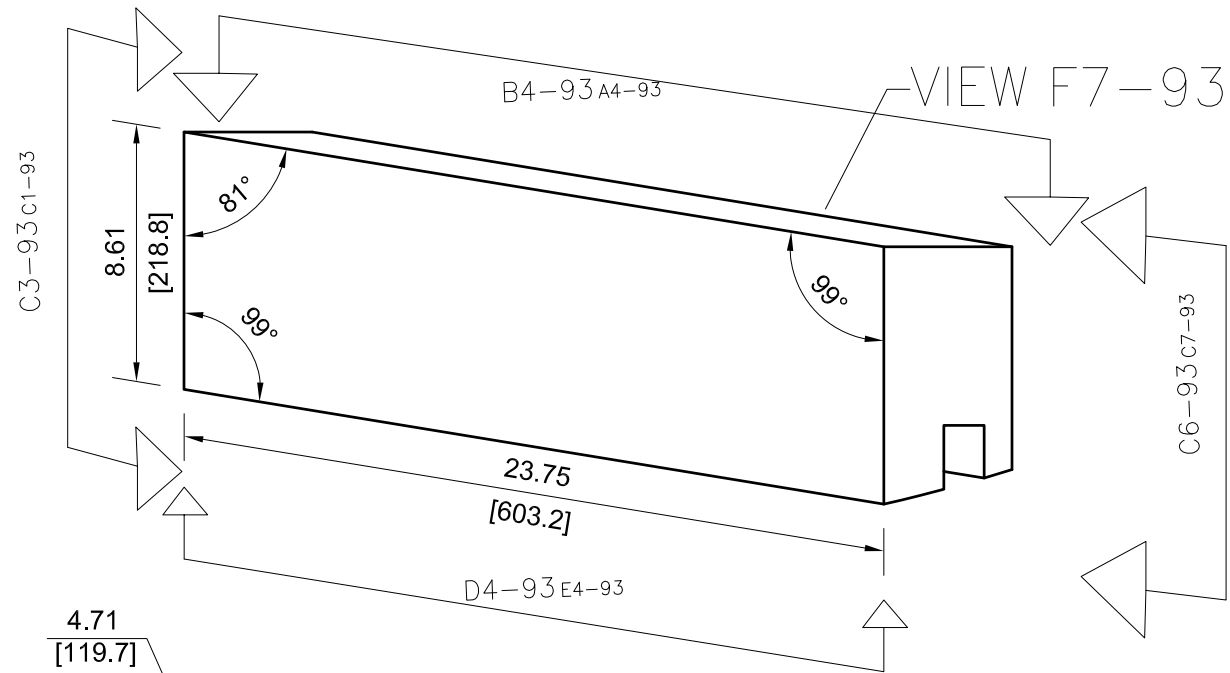

VIEW F7-93

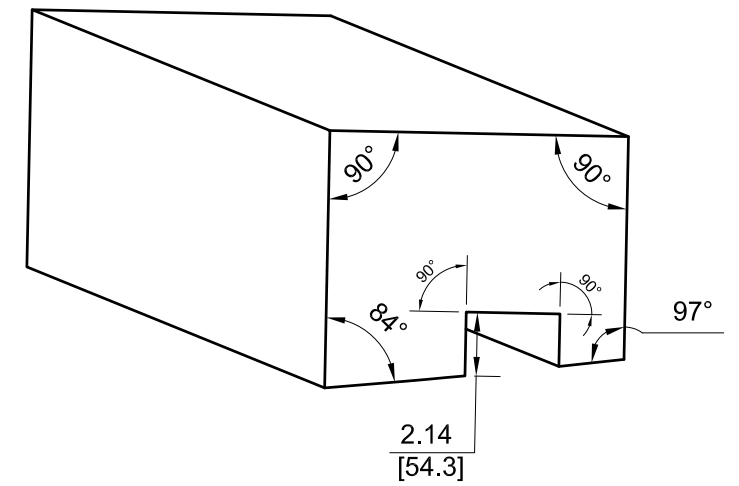

VIEW C6-93

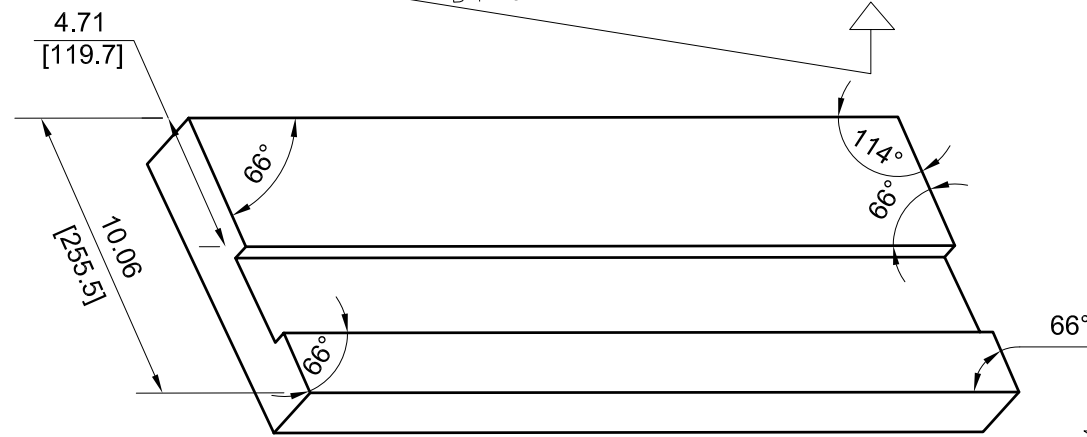

VIEW D4-93

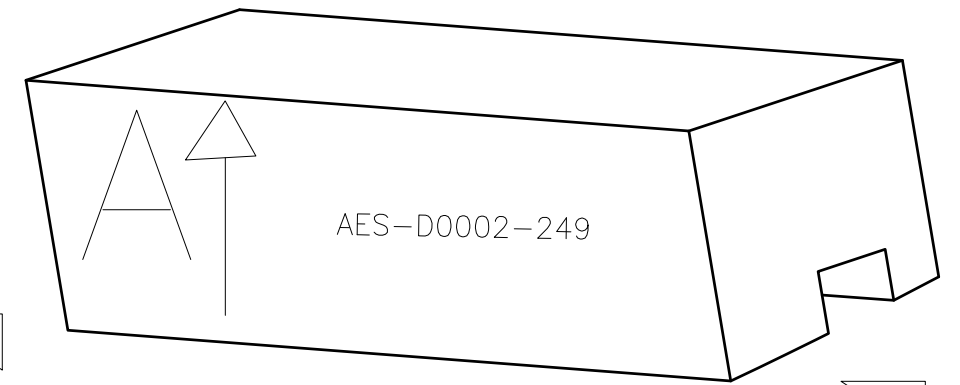

F7-93 C5-93

NOTE: ALL VIEWS TAKEN AS TRUE VIEWS PARALLEL TO SURFACE OF PART



DRAWING NUMBER				
AES-D0002				
SIZE	SCALE	SHEET	OF	REVISION
A3	NONE	93	167	F

-251

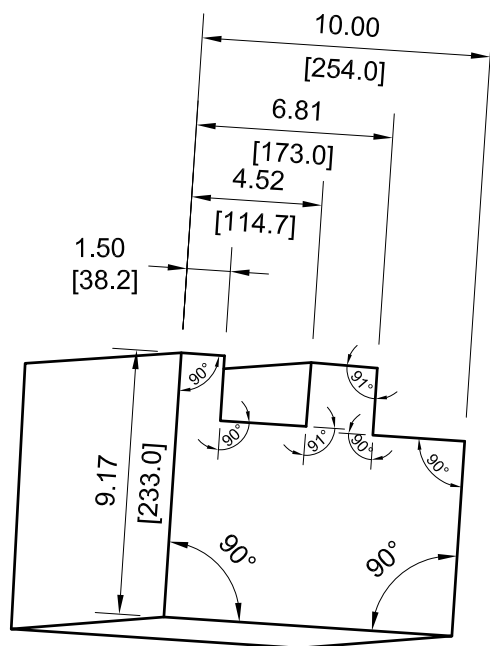

VIEW D6-94

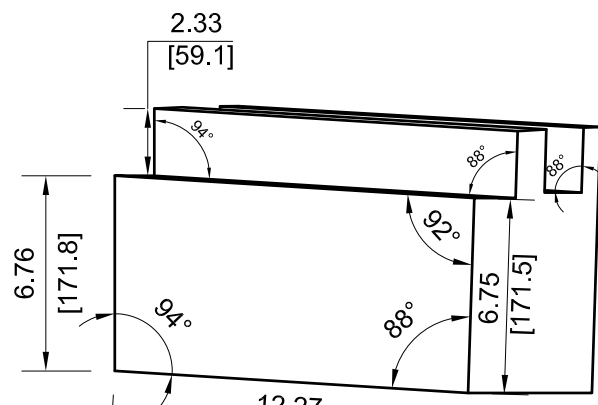

VIEW E6-94

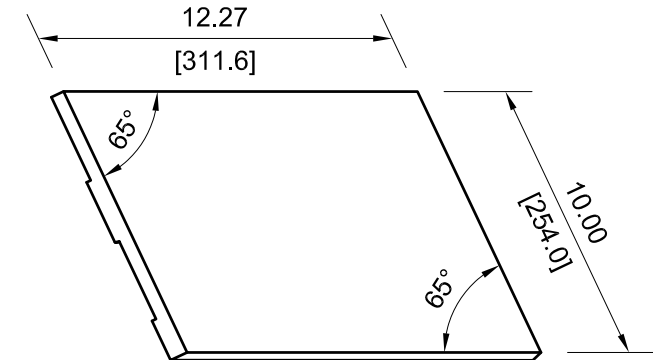

VIEW D3-94

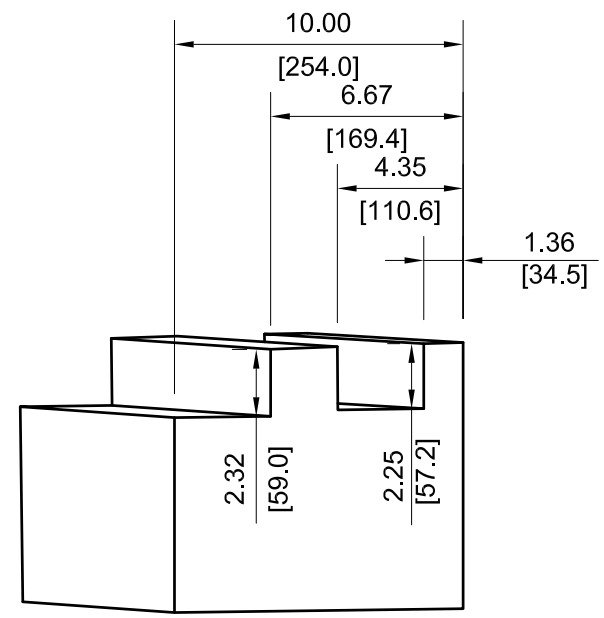

VIEW 1C5-94

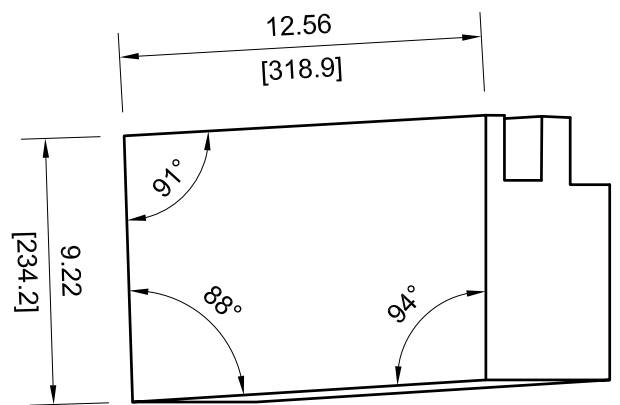

VIEW D8-94

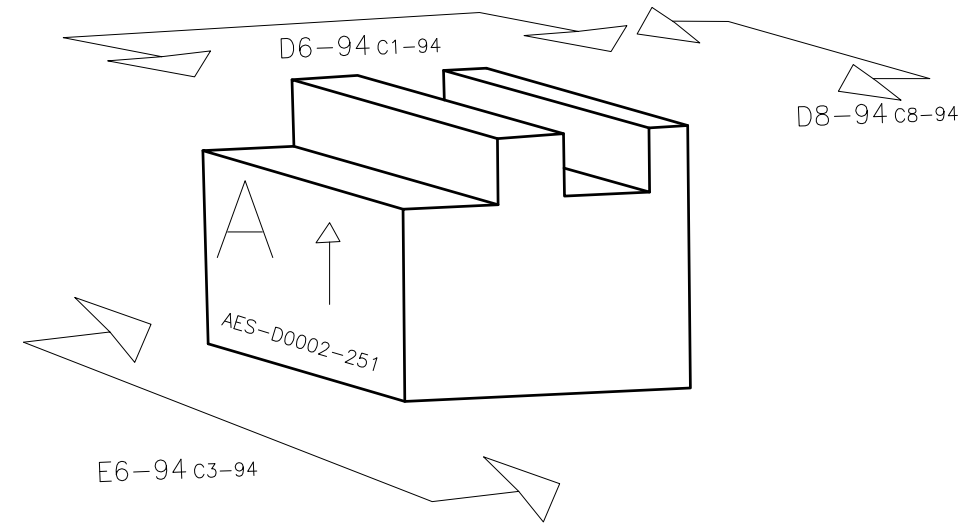

NOTE: ALL VIEWS TAKEN AS TRUE VIEWS PARALLEL TO SURFACE OF PART

		DRAWING NUMBER			
		AES-D0002			
SIZE	SCALE	SHEET	OF	REVISION	
A3	NONE	94	167	F	

-253

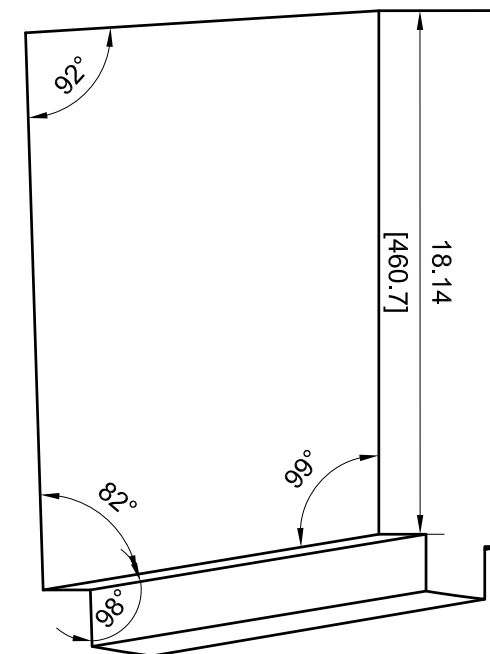
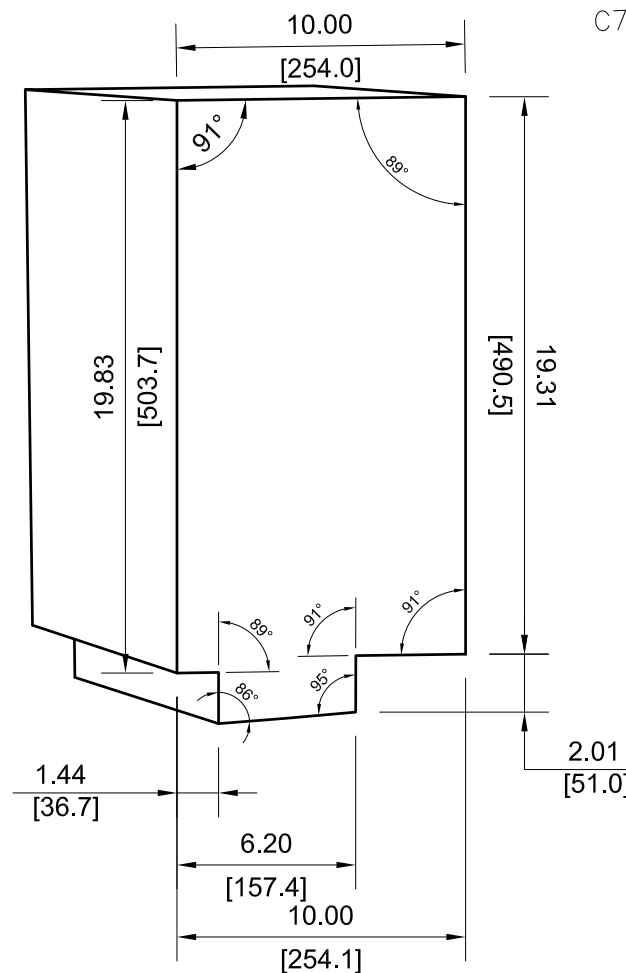
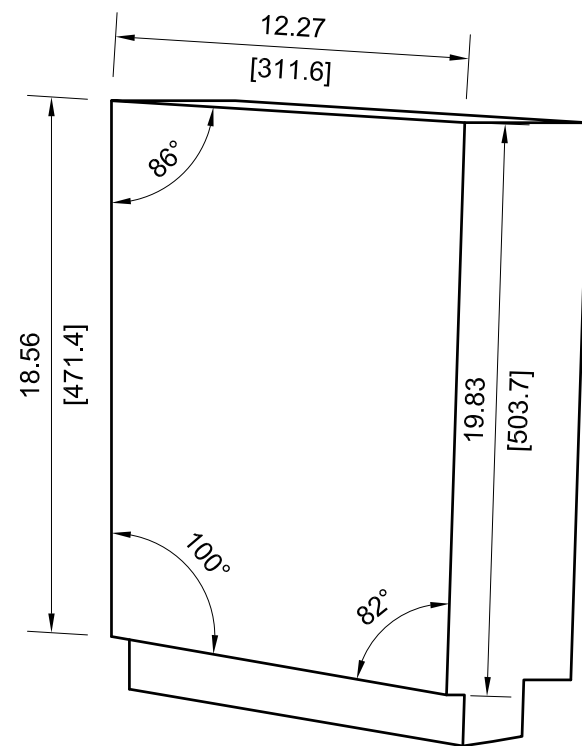
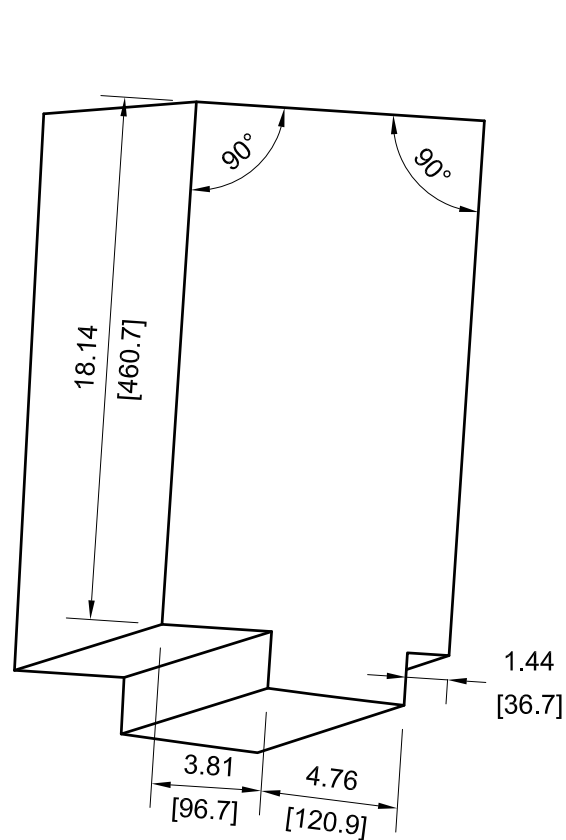
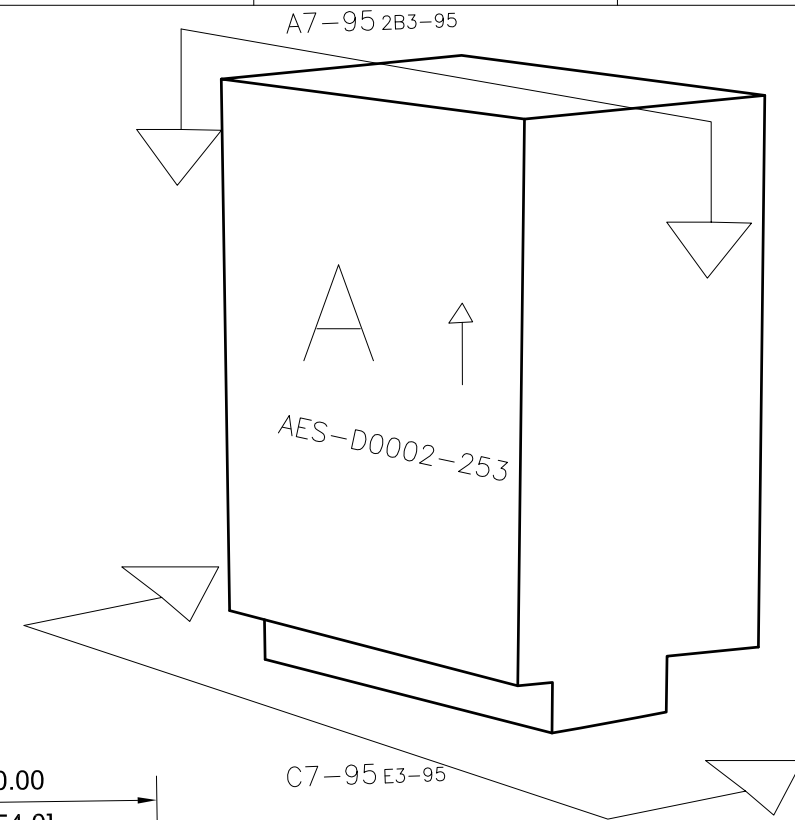
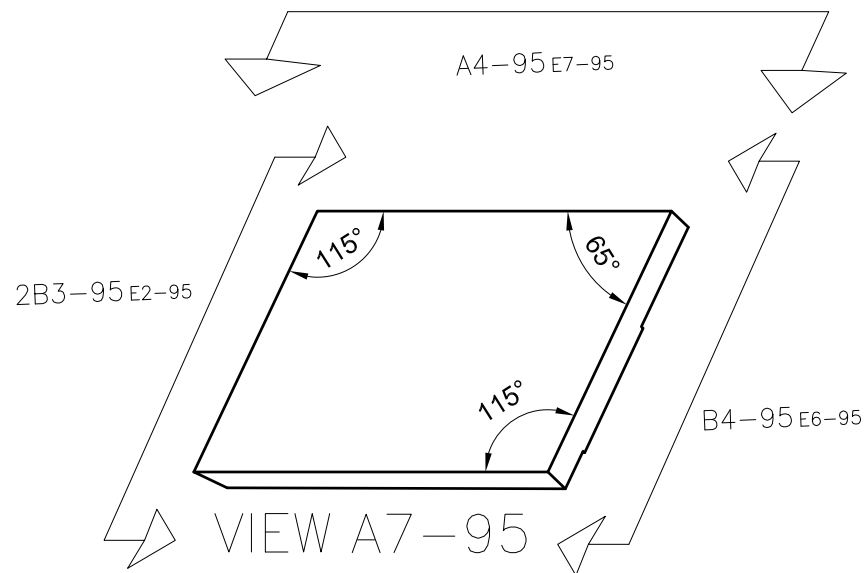

NOTE: ALL VIEWS TAKEN AS TRUE VIEWS PARALLEL TO SURFACE OF PART

		DRAWING NUMBER			
		AES-D0002			
SIZE	SCALE	SHEET	OF	REVISION	
A3	NONE	95	167	F	

-255

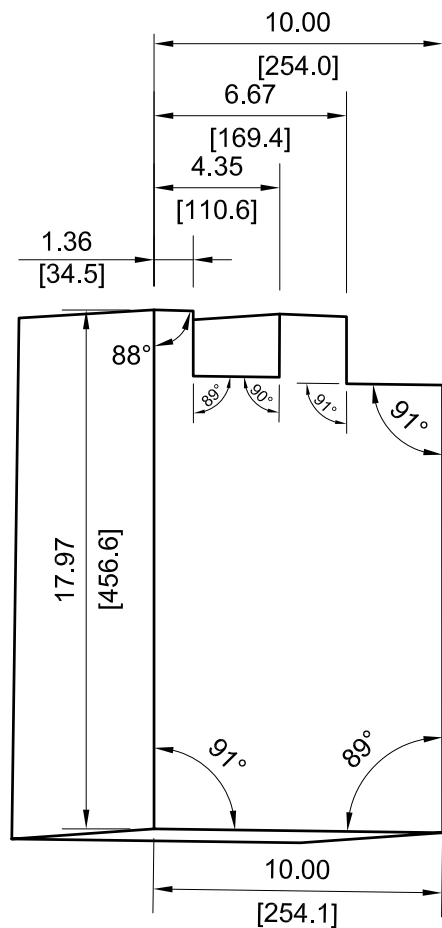

VIEW C2-96

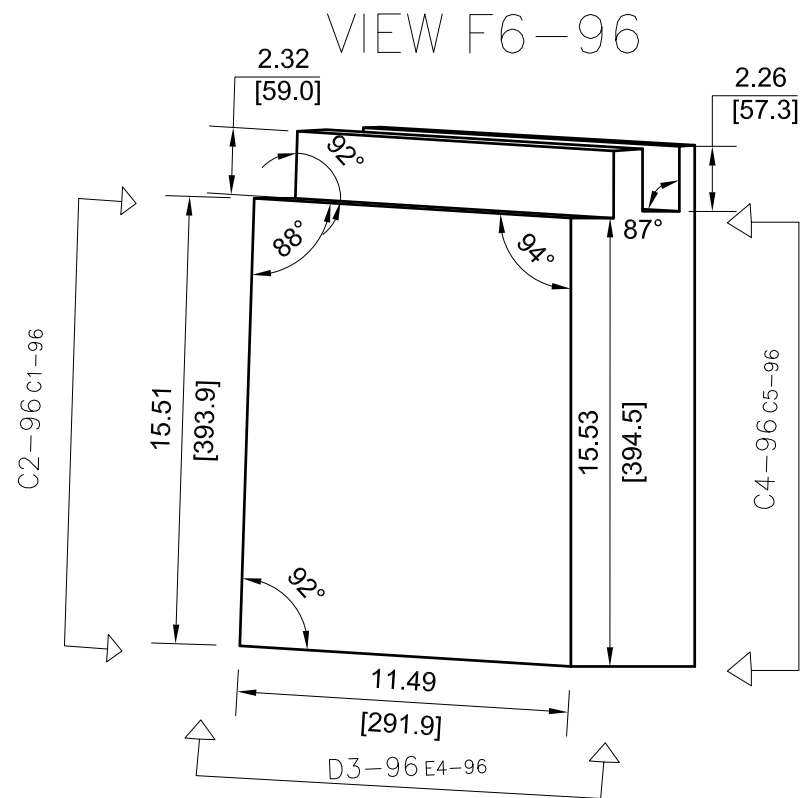

VIEW F6-96

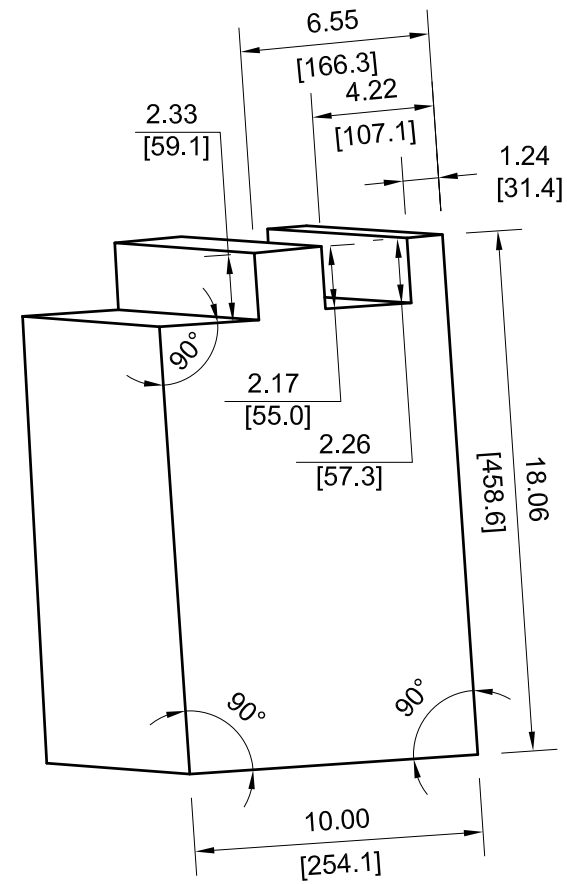

VIEW C4-96

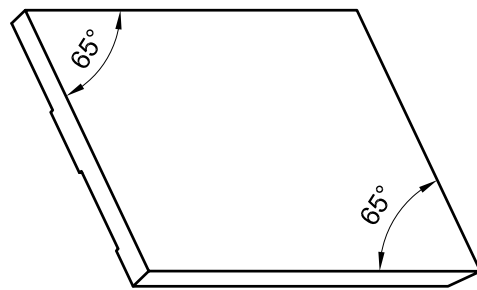

VIEW D3-96

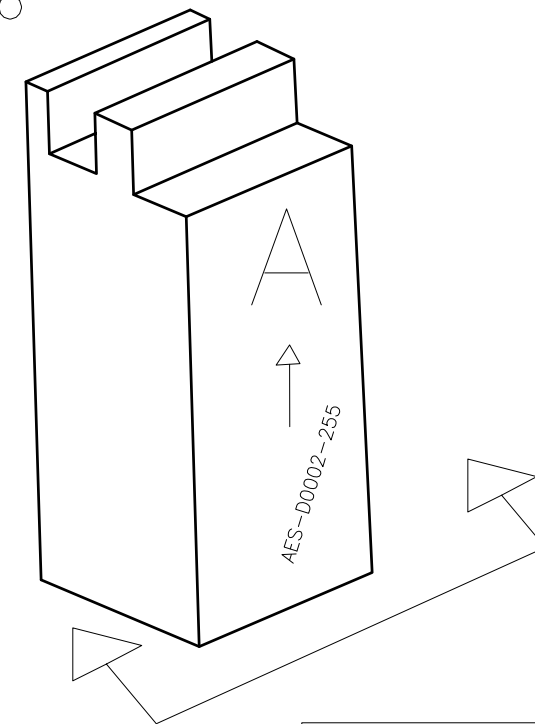

F6-96 C3-96

NOTE: ALL VIEWS TAKEN AS TRUE VIEWS PARALLEL TO SURFACE OF PART

		DRAWING NUMBER			
		AES-D0002			
SIZE	SCALE	SHEET	OF	REVISION	
A3	NONE	96	167	F	

-257

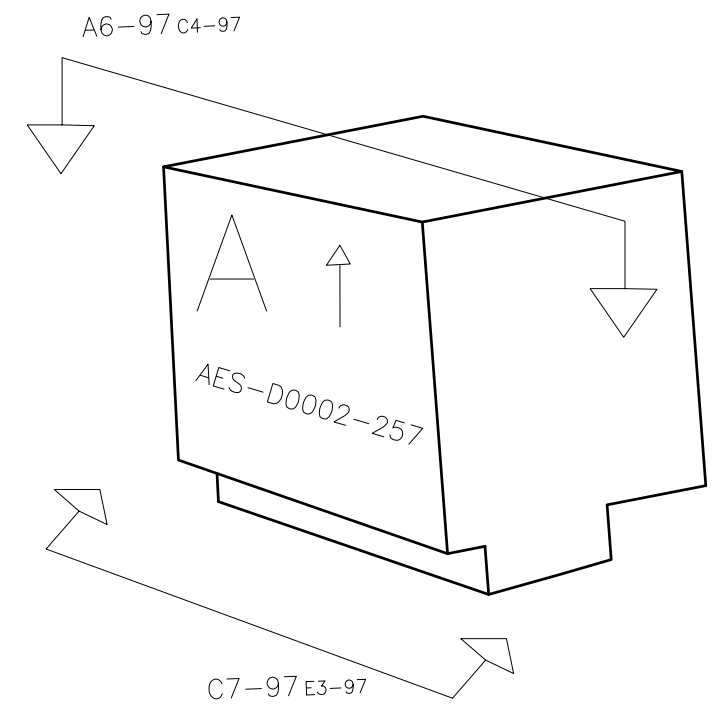
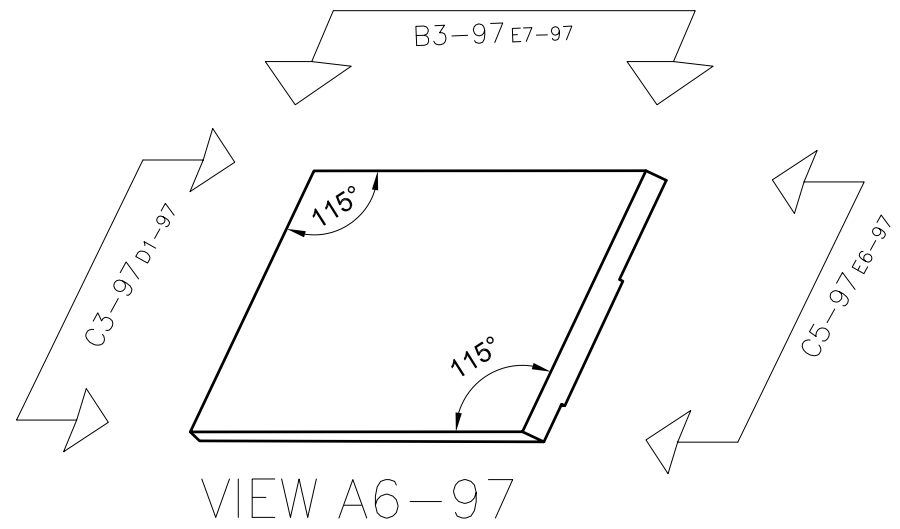

VIEW C3-97

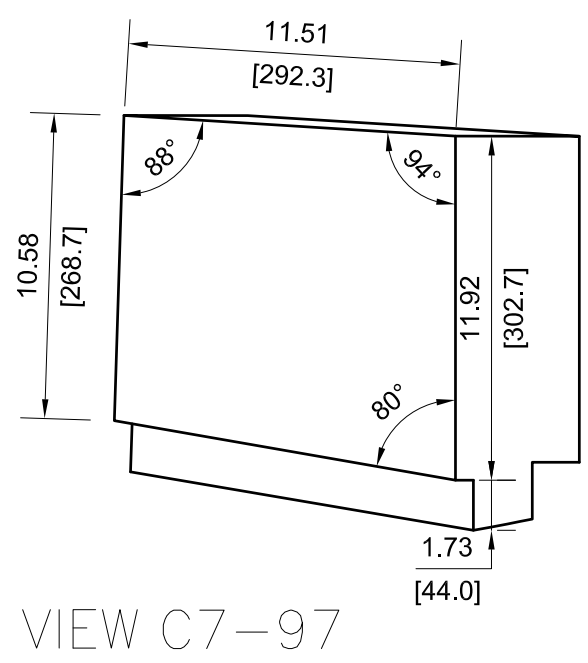
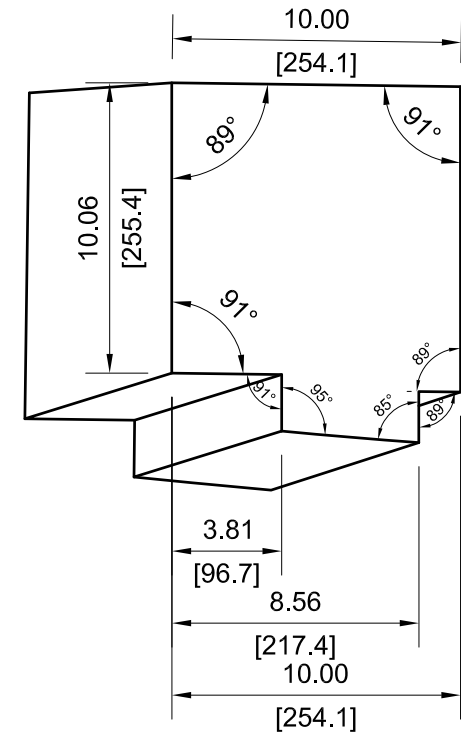

VIEW C5-97

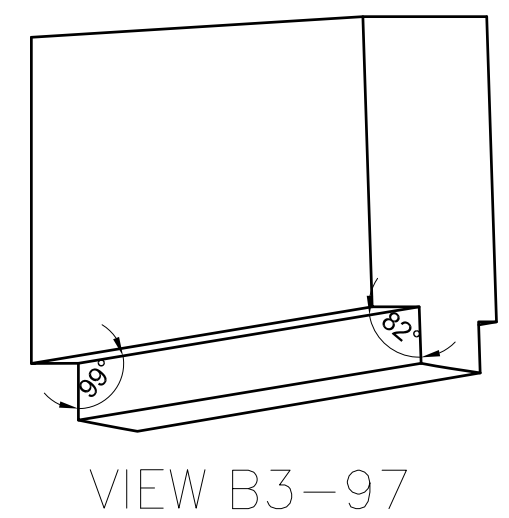
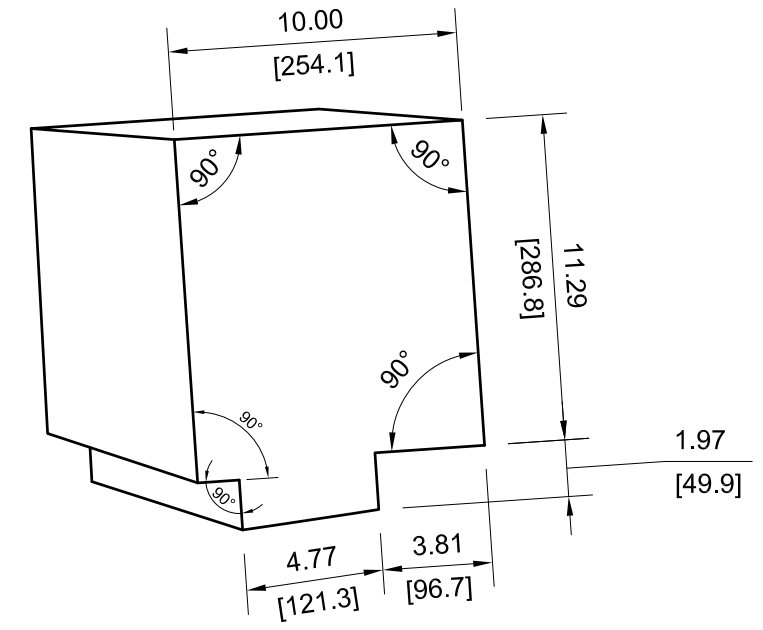

NOTE: ALL VIEWS TAKEN AS TRUE VIEWS PARALLEL TO SURFACE OF PART

		DRAWING NUMBER			
		AES-D0002			
SIZE	SCALE	SHEET	OF	REVISION	
A3	NONE	97	167	F	

-259

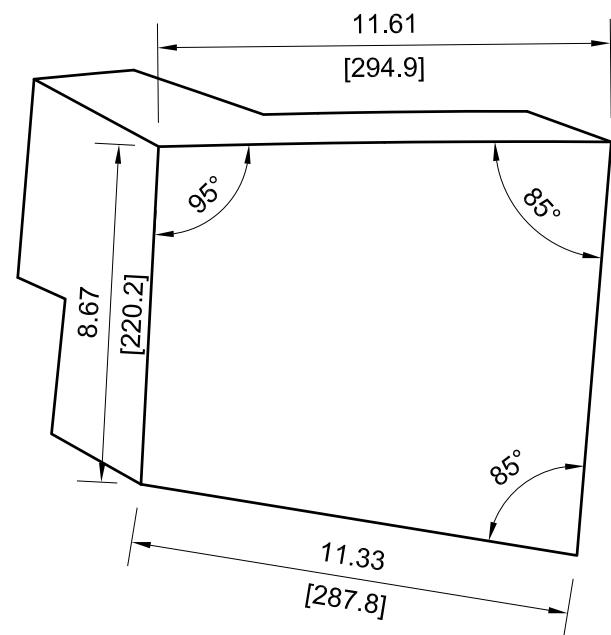

VIEW D6-98

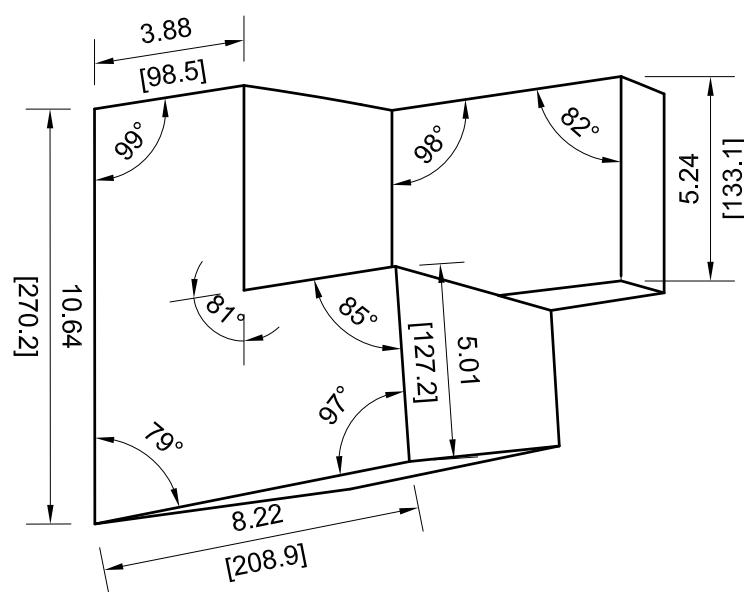

VIEW F6-98

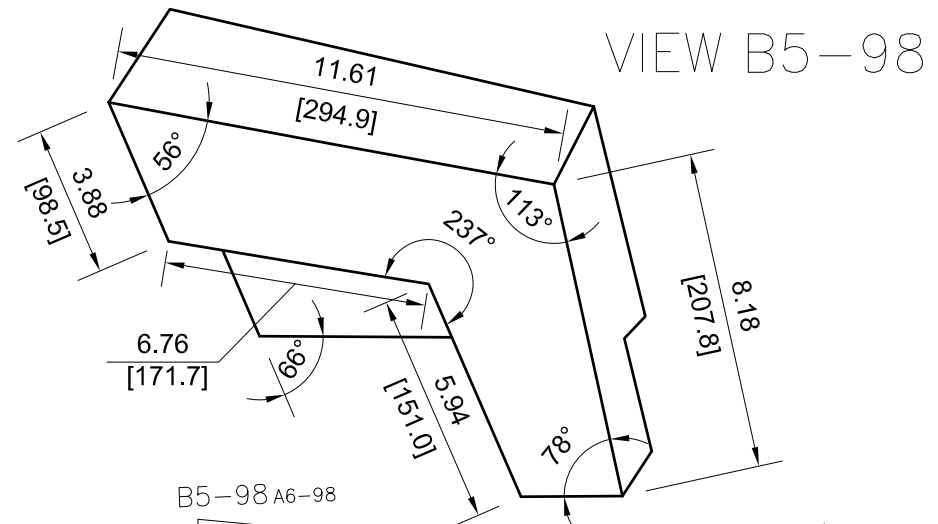

VIEW B5-98

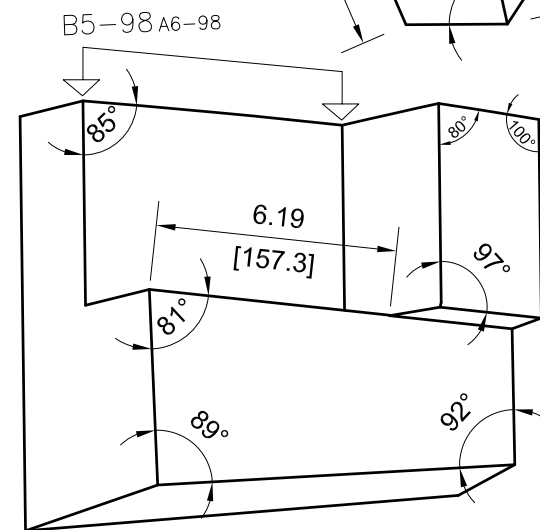

VIEW F8-98

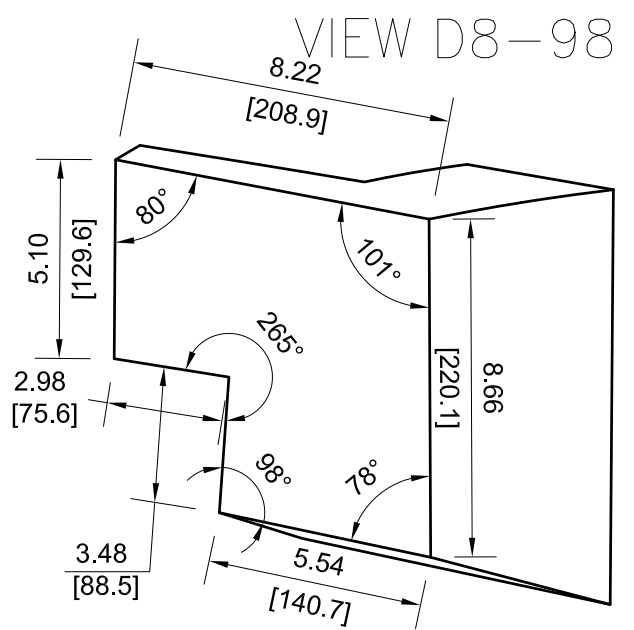

VIEW D8-98

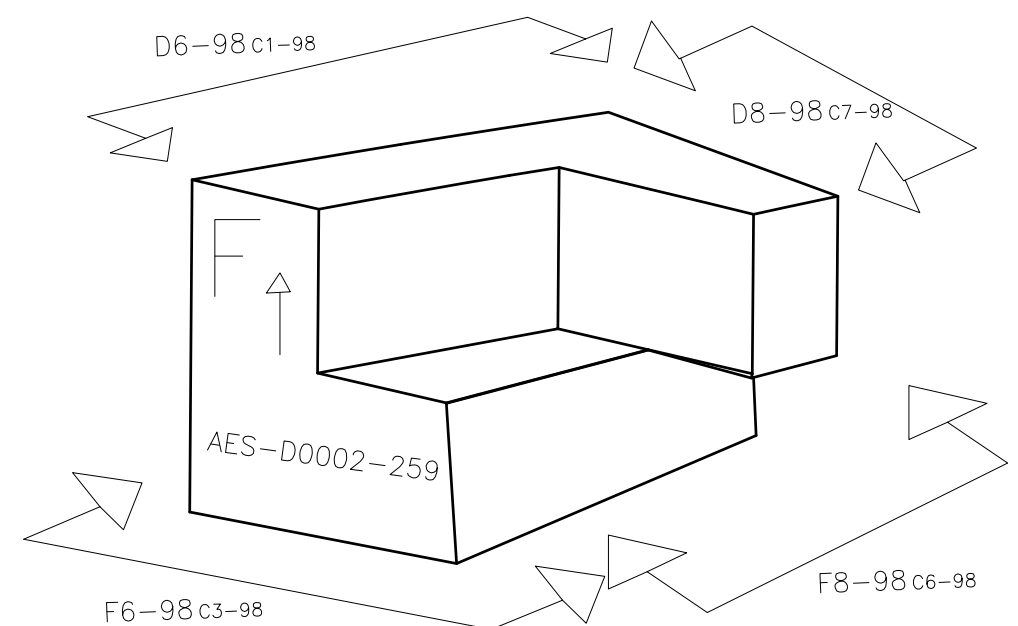

NOTE: ALL VIEWS TAKEN AS TRUE VIEWS PARALLEL TO SURFACE OF PART

		DRAWING NUMBER			
		AES-D0002			
SIZE	SCALE	SHEET	OF	REVISION	
A3	NONE	98	167	F	

-261

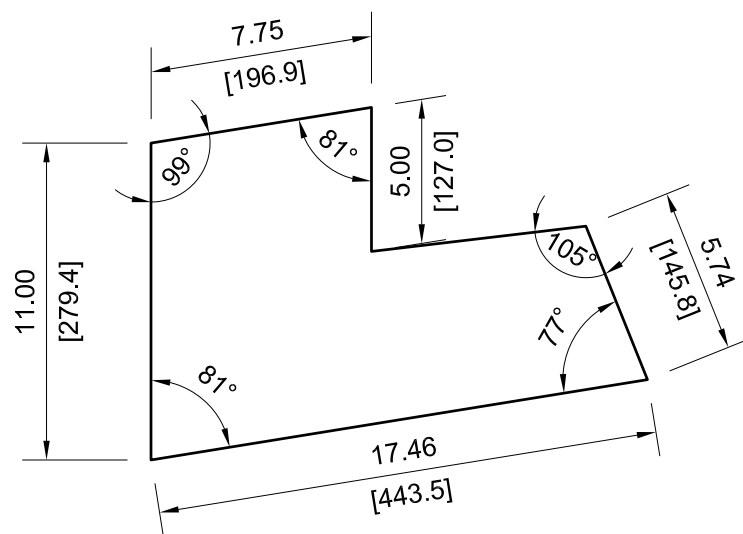
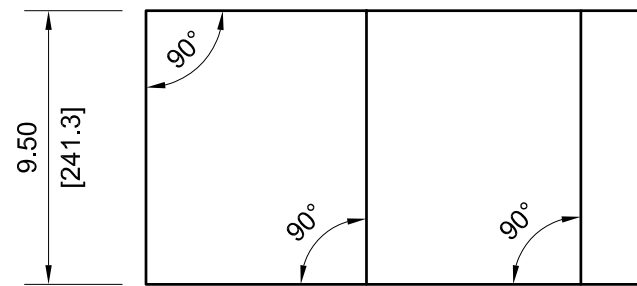
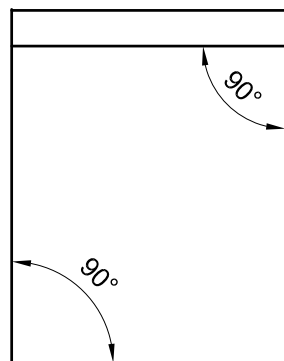

VIEW E7-99

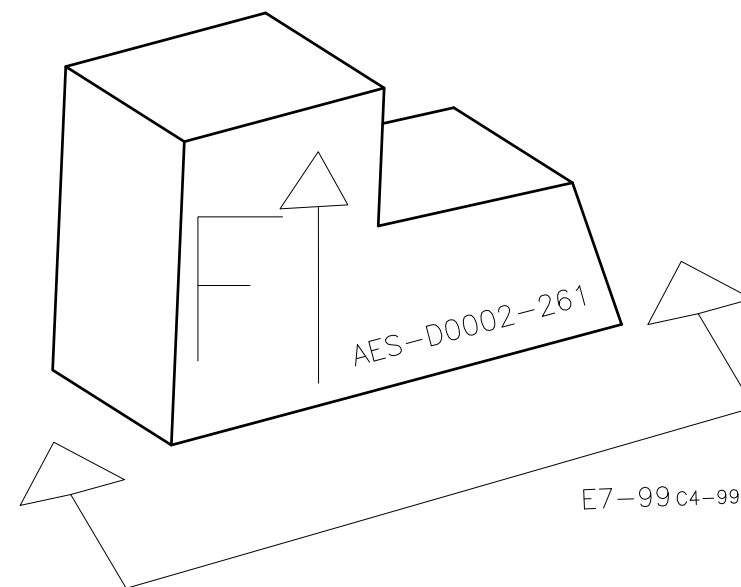

NOTE: ALL VIEWS TAKEN AS TRUE VIEWS PARALLEL TO SURFACE OF PART



DRAWING NUMBER				
AES-D0002				
SIZE	SCALE	SHEET	OF	REVISION
A3	NONE	99	167	F

-263

VIEW A7-100

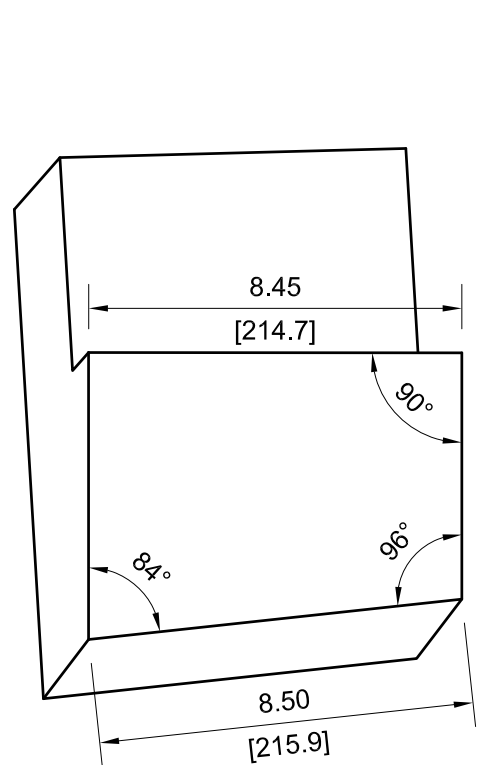
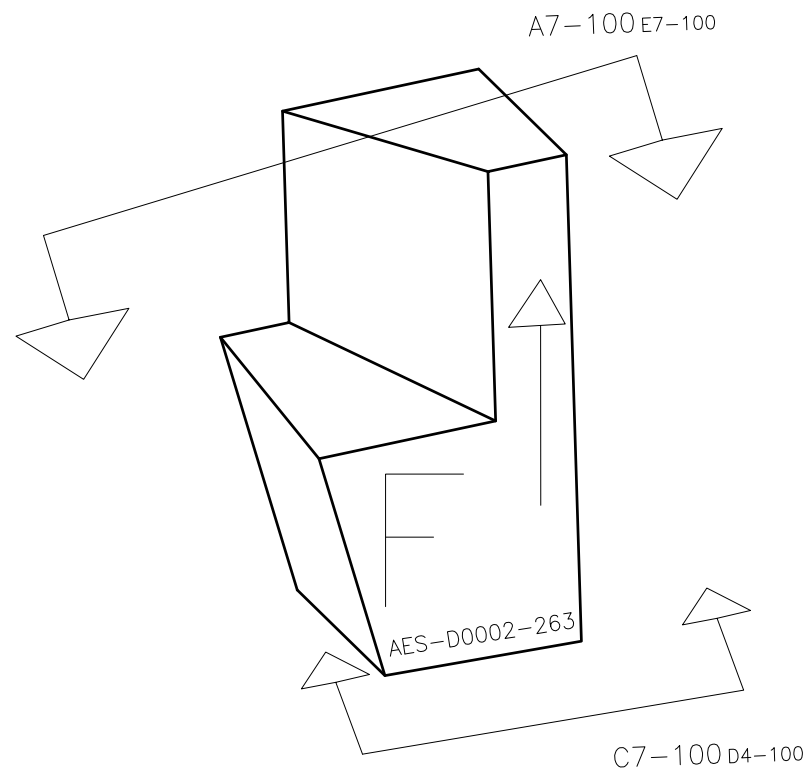
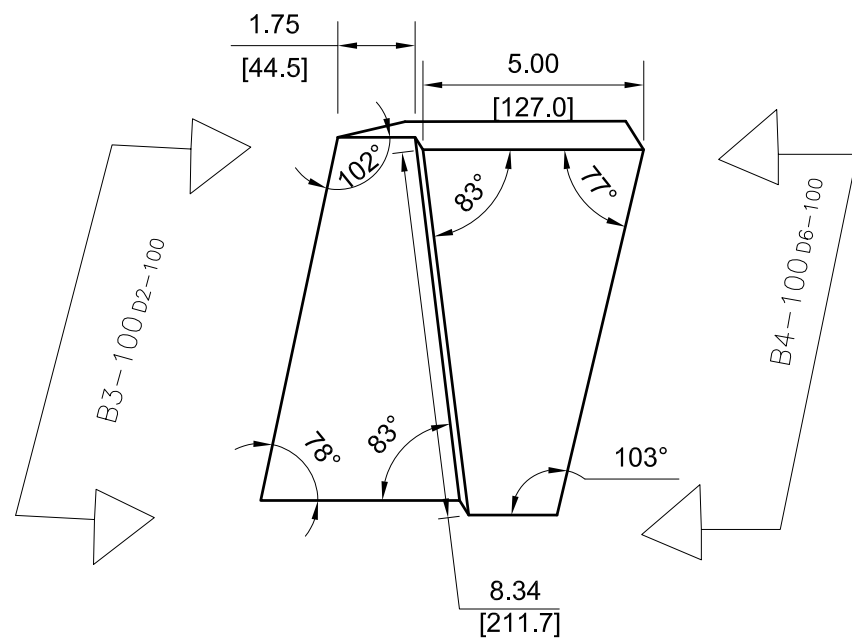

VIEW B3-100

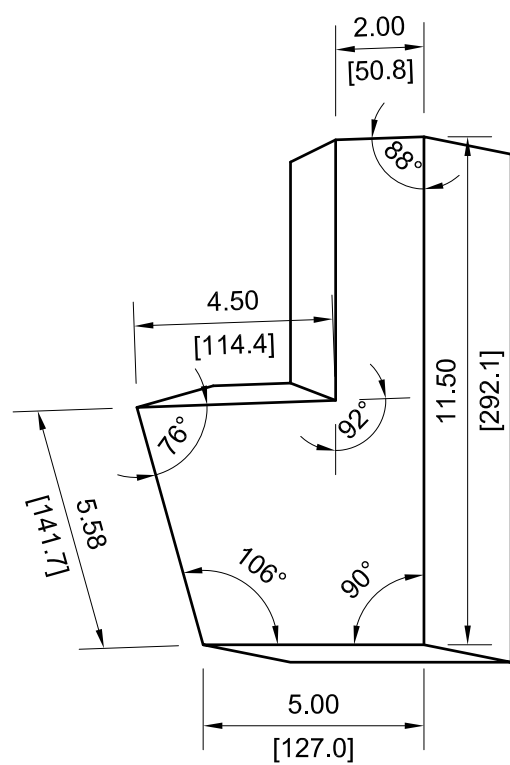

VIEW C7-100

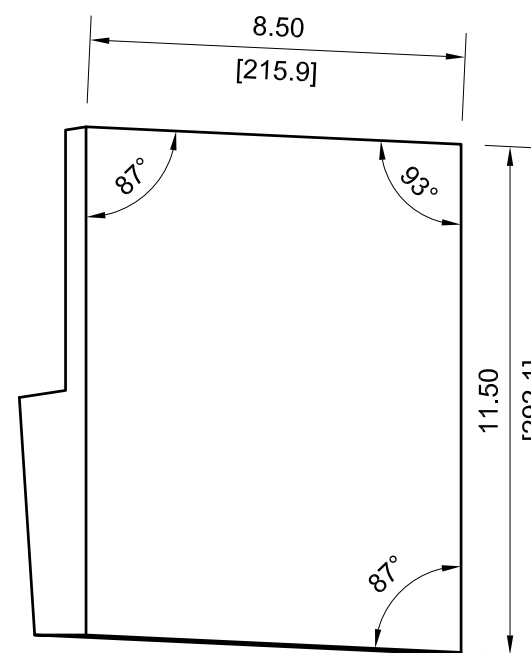

VIEW B4-100

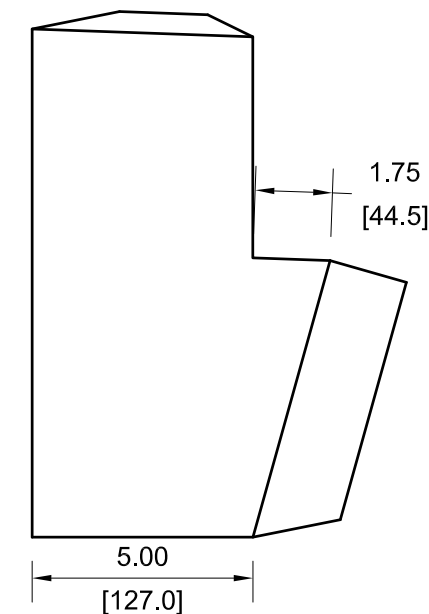

VIEW A7-100

NOTE: ALL VIEWS TAKEN AS TRUE VIEWS PARALLEL TO SURFACE OF PART

	DRAWING NUMBER				AES-D0002
	SIZE	SCALE	SHEET	OF	REVISION
A3	NONE	100	167	F	

-265

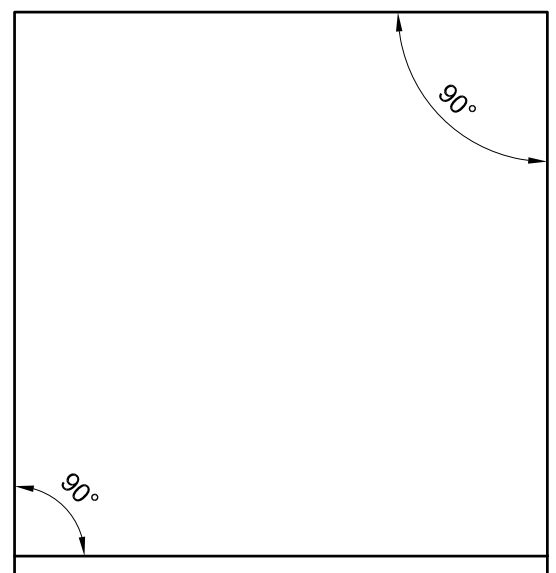
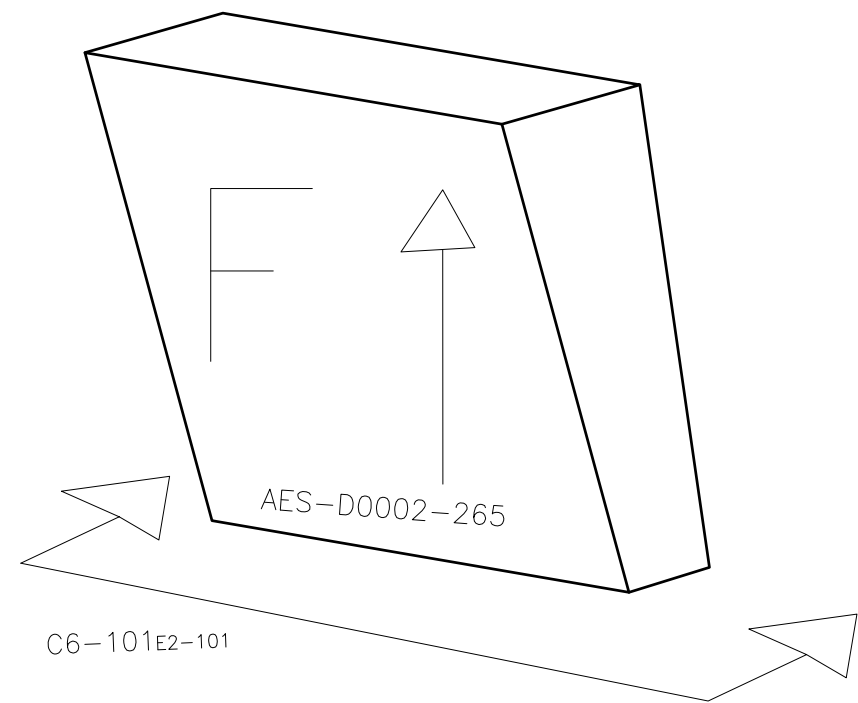
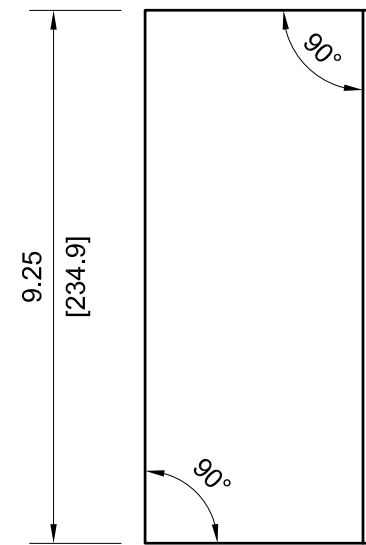

VIEW C6-101

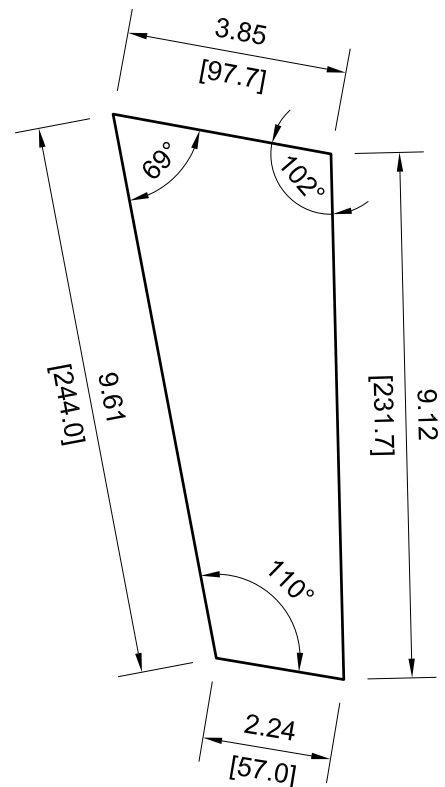

NOTE: ALL VIEWS TAKEN AS TRUE VIEWS PARALLEL TO SURFACE OF PART



DRAWING NUMBER				
AES-D0002				
SIZE	SCALE	SHEET	OF	REVISION
A3	NONE	101	167	F

-267

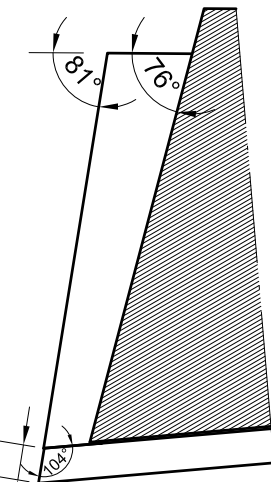

SECTION VIEW E3-102

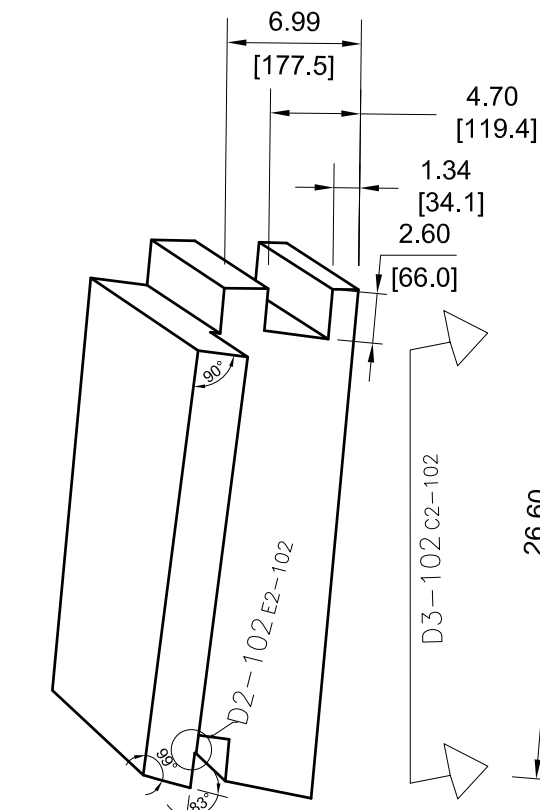
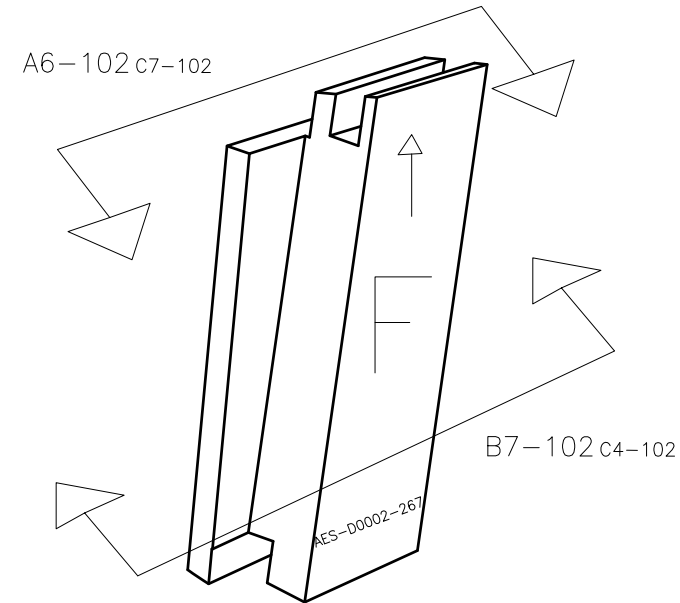

VIEW D3-102

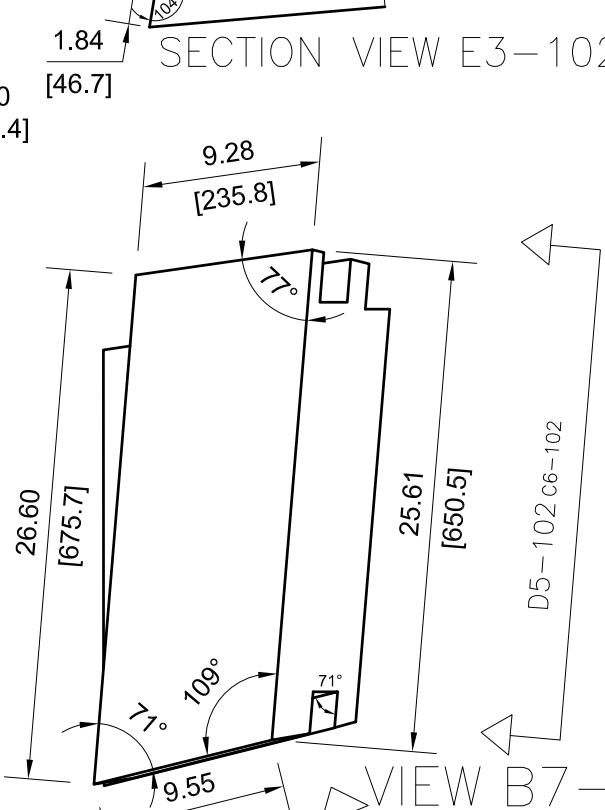

VIEW B7-102

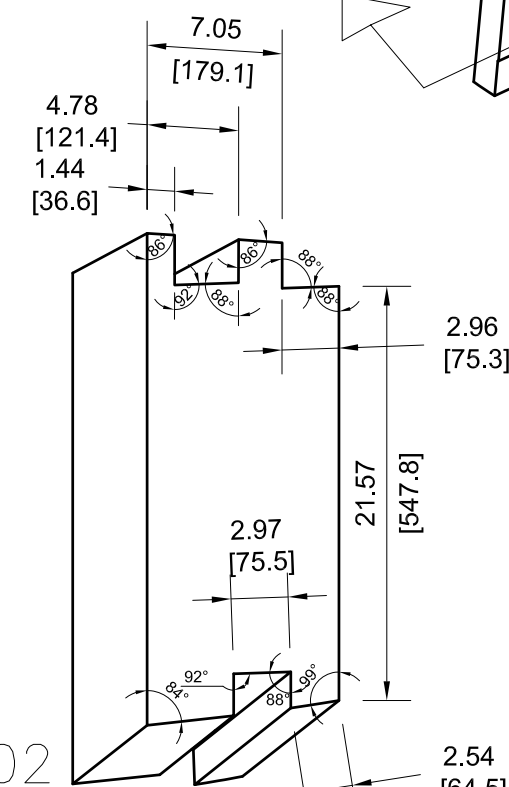

VIEW D5-102

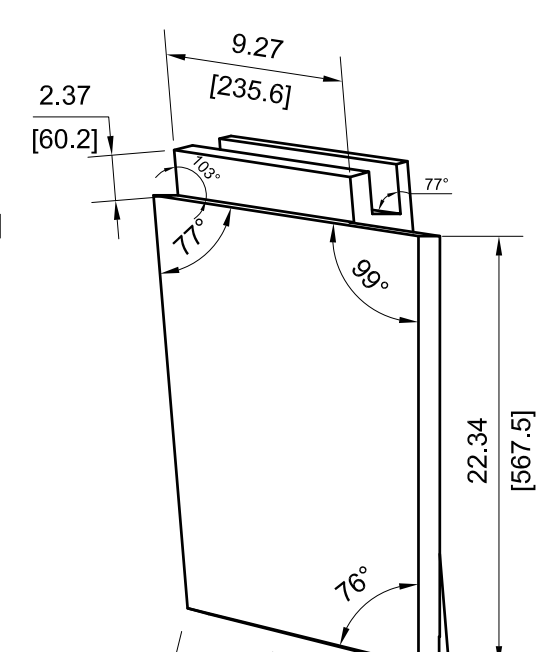

VIEW A6-102

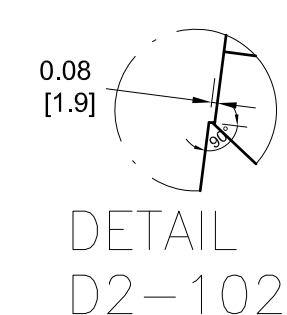

DETAIL D2-102

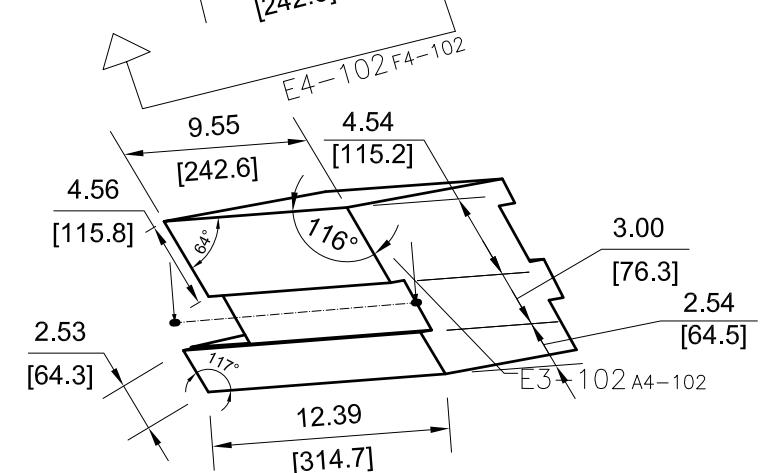

VIEW E4-102

NOTE: ALL VIEWS TAKEN AS TRUE VIEWS PARALLEL TO SURFACE OF PART

		DRAWING NUMBER			
		AES-D0002			
SIZE	SCALE	SHEET	OF	REVISION	
A3	NONE	102	167	F	

— 269

VIEW C4-103

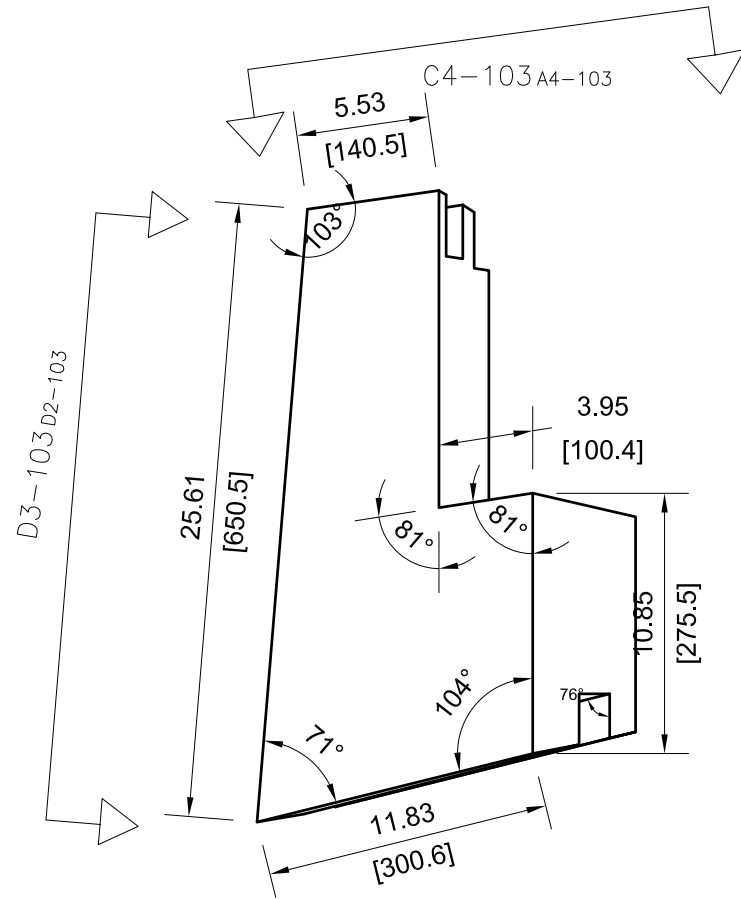
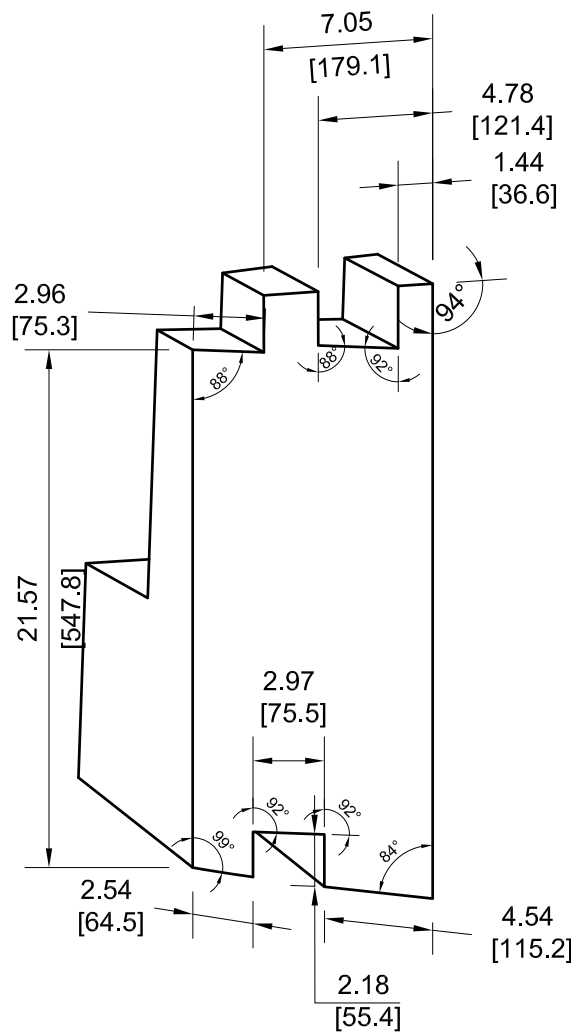
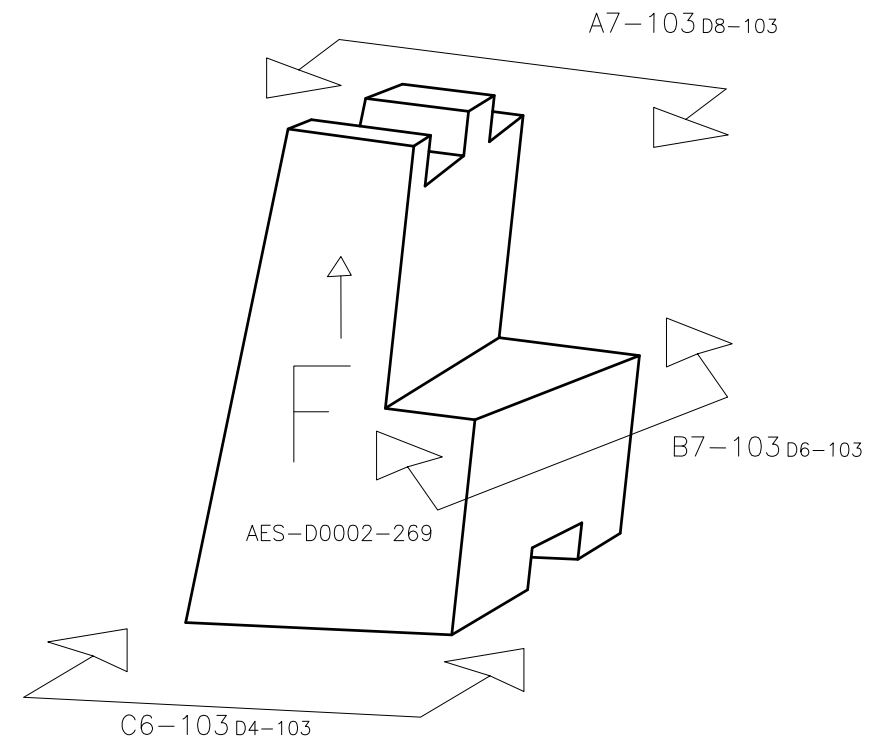
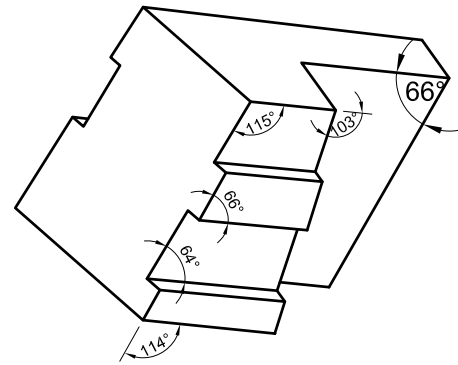

VIEW C6-103

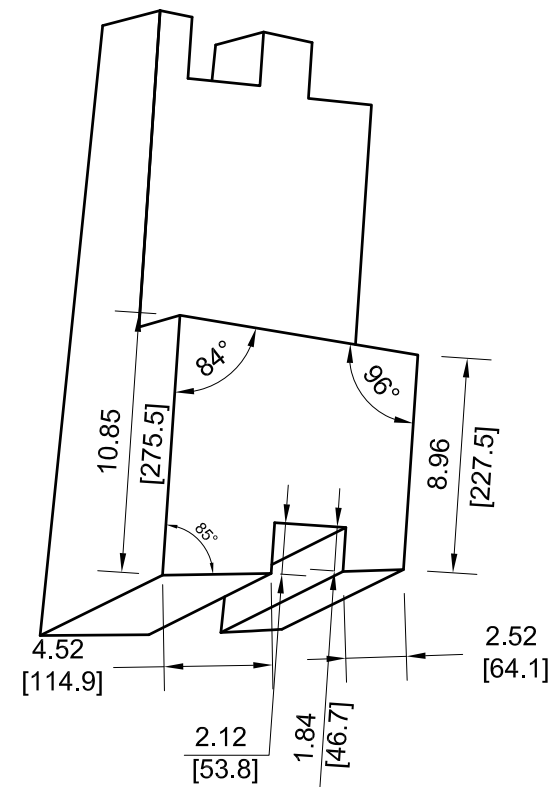

VIEW B7-103

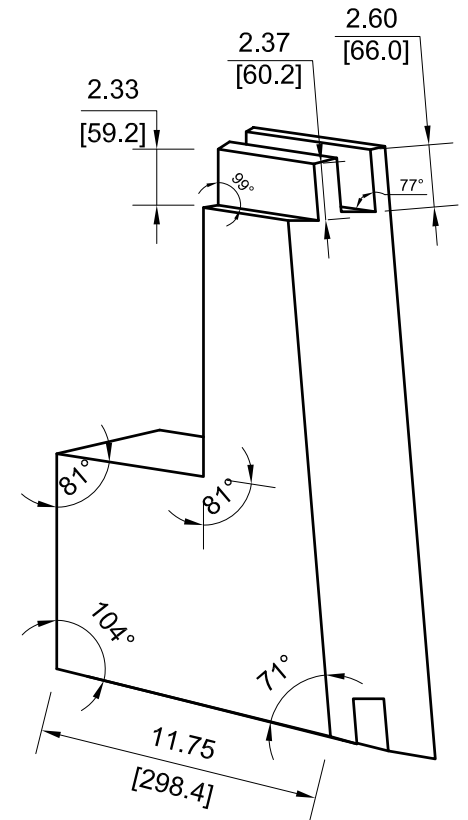

VIEW A7-103

VIEW D3-103

NOTE: ALL VIEWS TAKEN AS TRUE VIEWS PARALLEL TO SURFACE OF PART

		DRAWING NUMBER			
		AES-D0002			
SIZE	SCALE	SHEET	OF	REVISION	
A3	NONE	103	167	F	

-271

VIEW C3-104

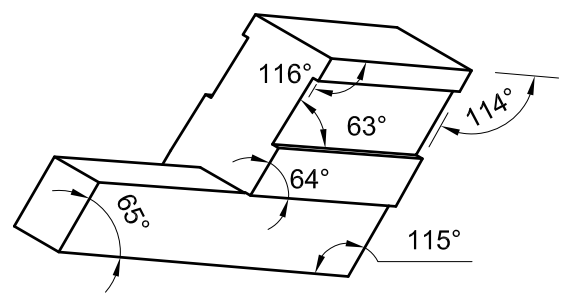

C3-104 B5-104

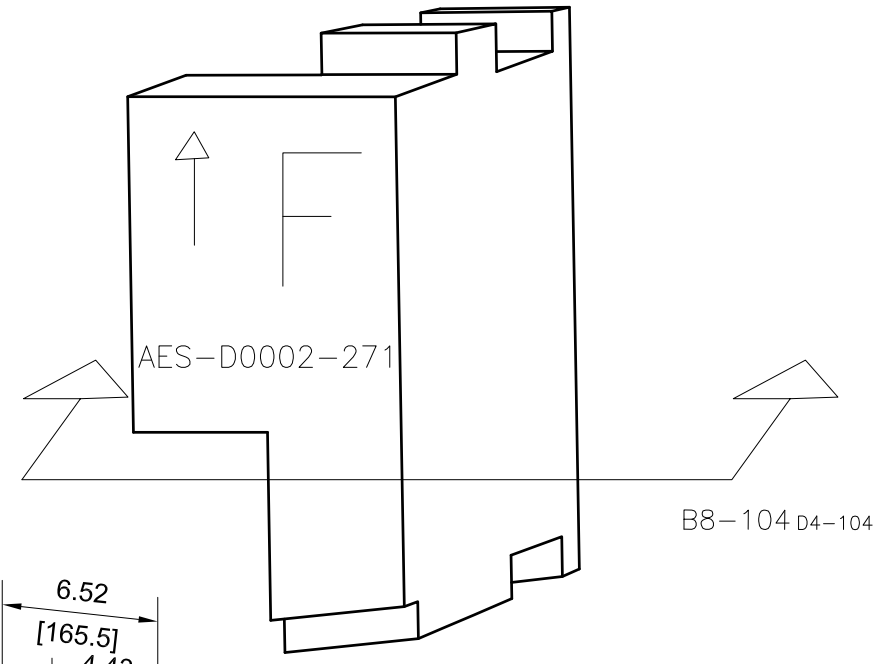

AES-D0002-271

B8-104 D4-104

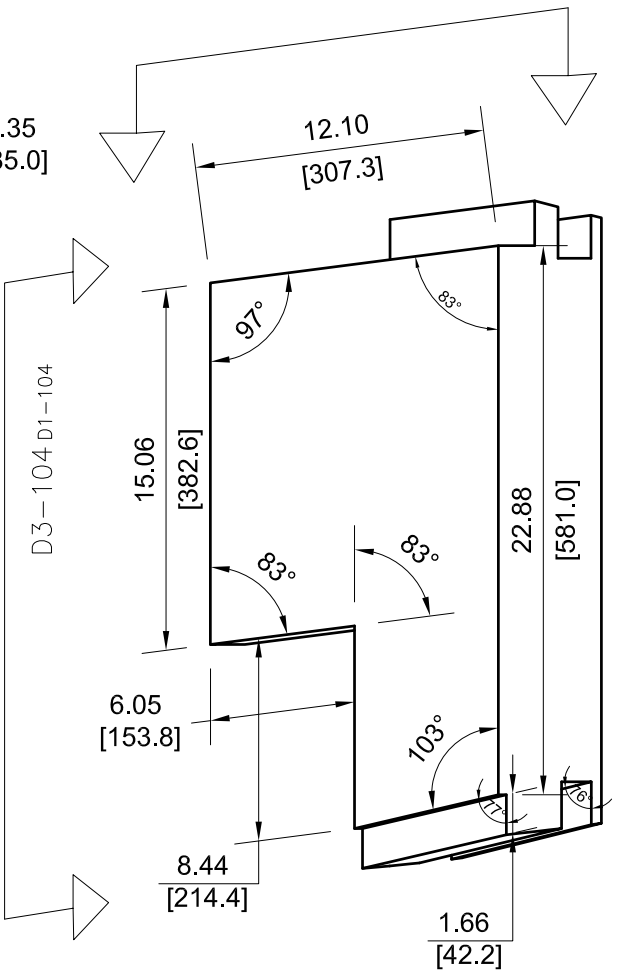
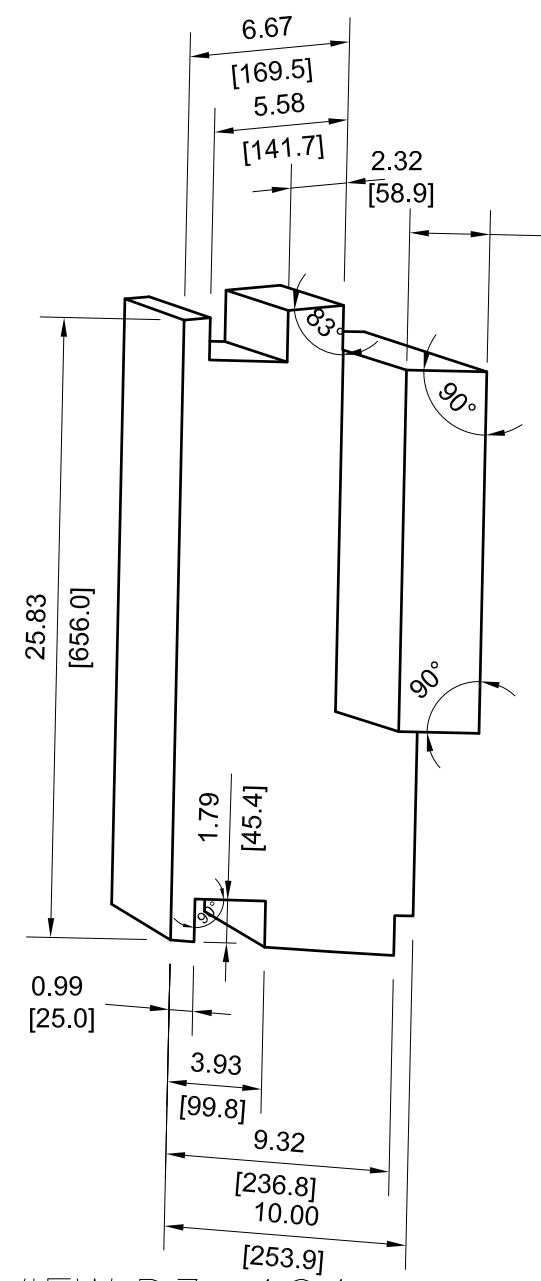

VIEW B8-104

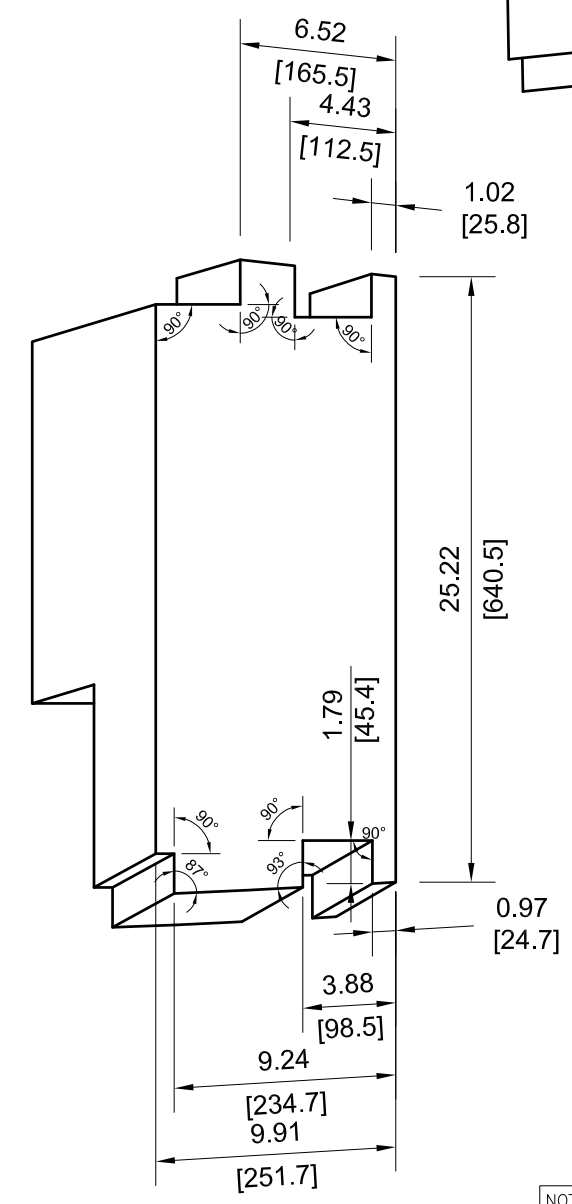

VIEW D5-104

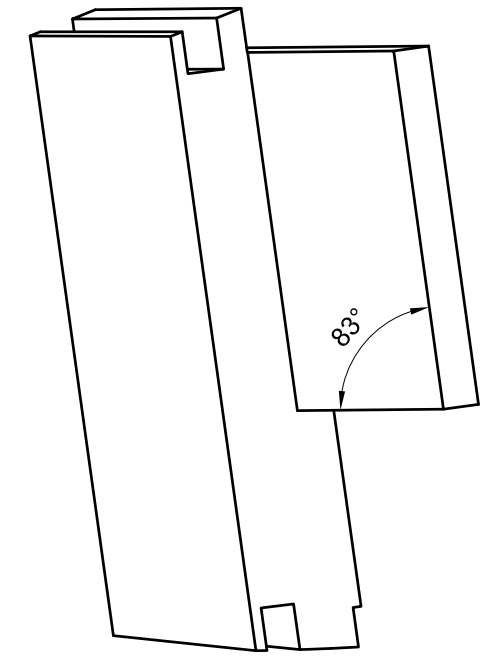

VIEW A7-104

VIEW D3-104

NOTE: ALL VIEWS TAKEN AS TRUE VIEWS PARALLEL TO SURFACE OF PART

	DRAWING NUMBER				
	AES-D0002				
SIZE	SCALE	SHEET	OF	REVISION	
A3	NONE	104	167	F	

-273

A3-105 D7-105

A6-105 A3-105

VIEW A6-105

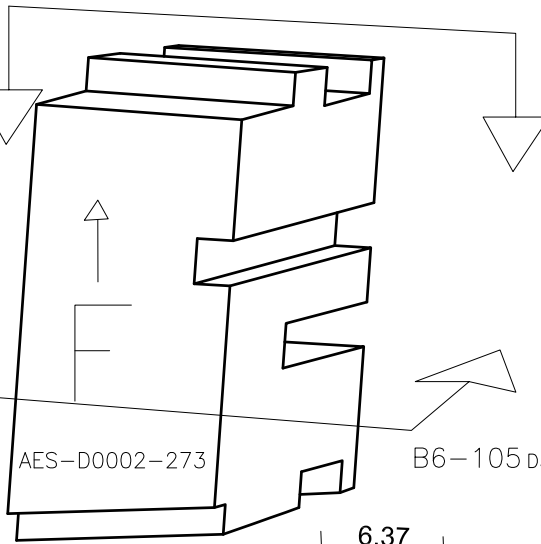
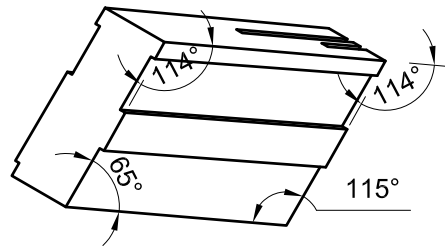

AES-D0002-273

B6-105 D3-105

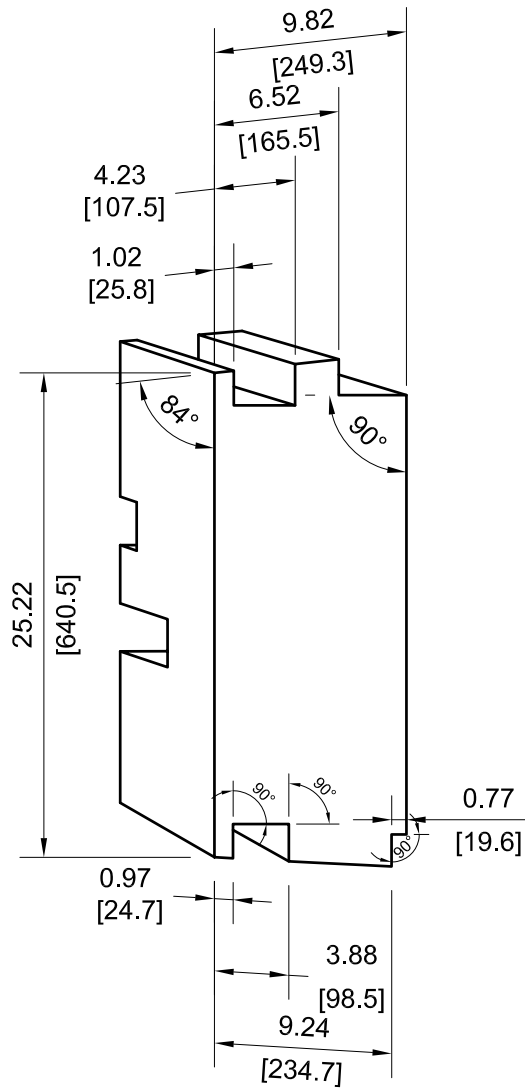

VIEW D2-105

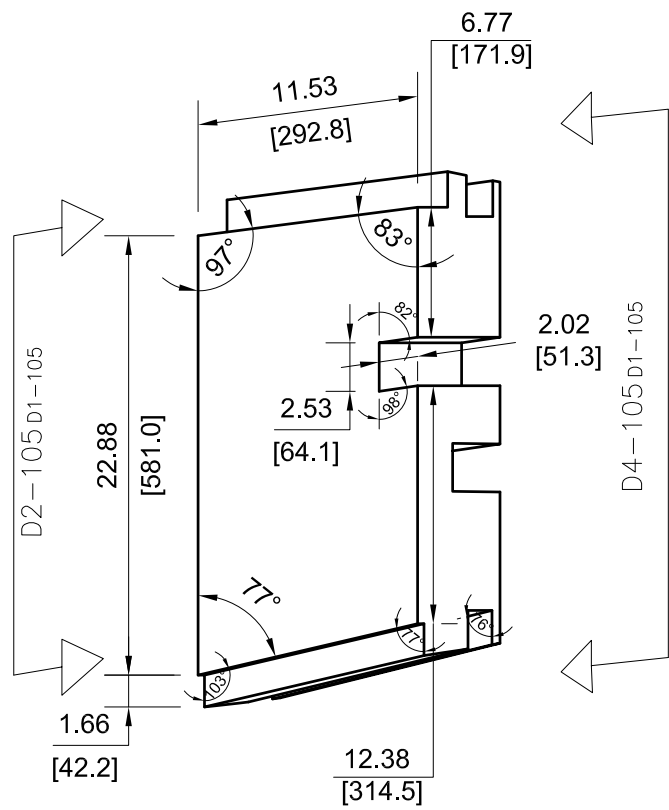

VIEW B6-105

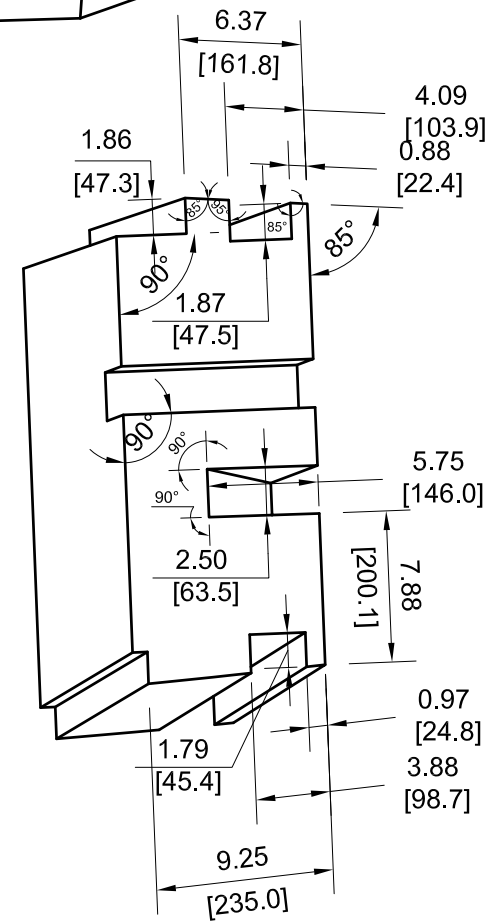

VIEW D4-105

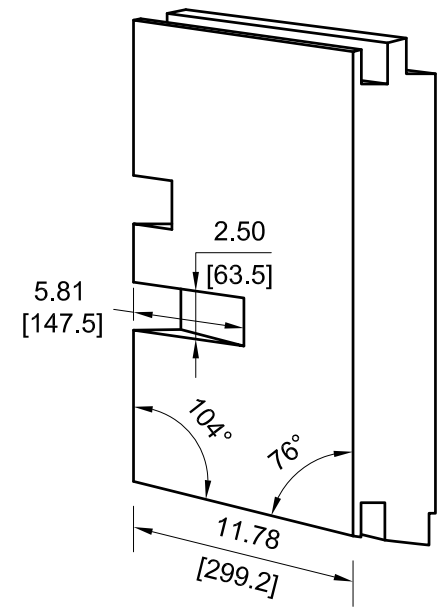

VIEW A3-105

NOTE: ALL VIEWS TAKEN AS TRUE VIEWS PARALLEL TO SURFACE OF PART

		DRAWING NUMBER			
		AES-D0002			
SIZE	SCALE	SHEET	OF	REVISION	
A3	NONE	105	167	F	

-275

A4-106 D7-106

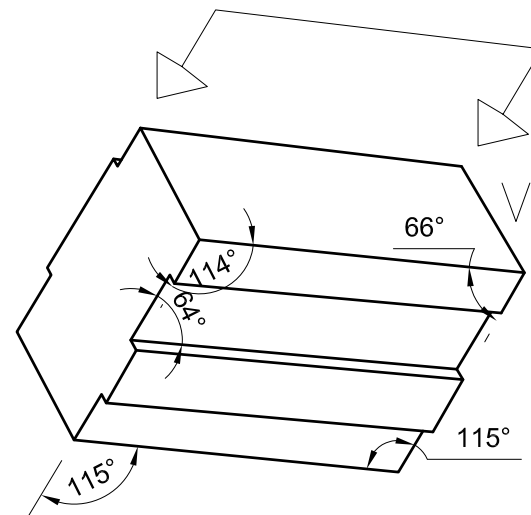

VIEW C3-106

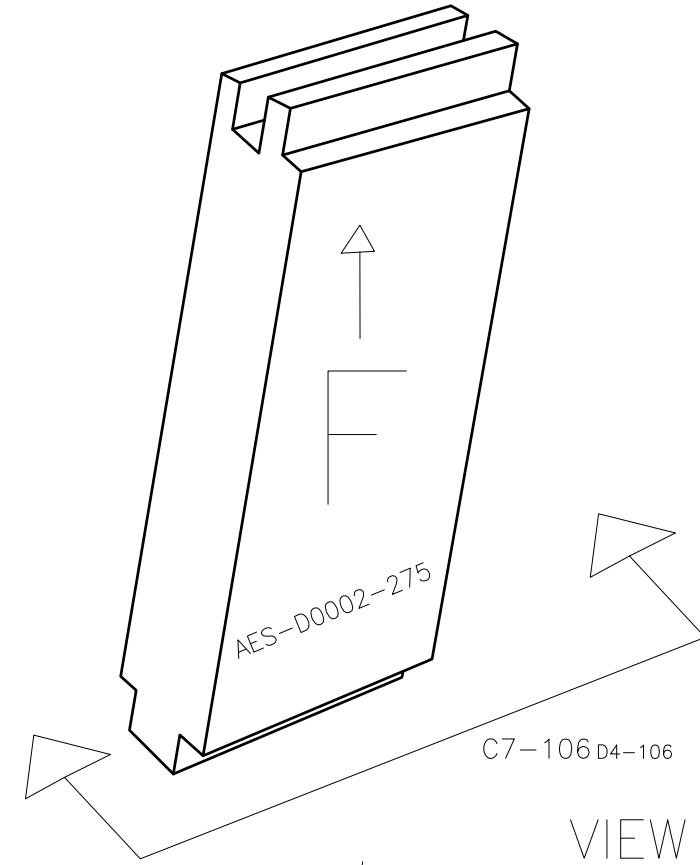

VIEW A4-106

VIEW E3-106

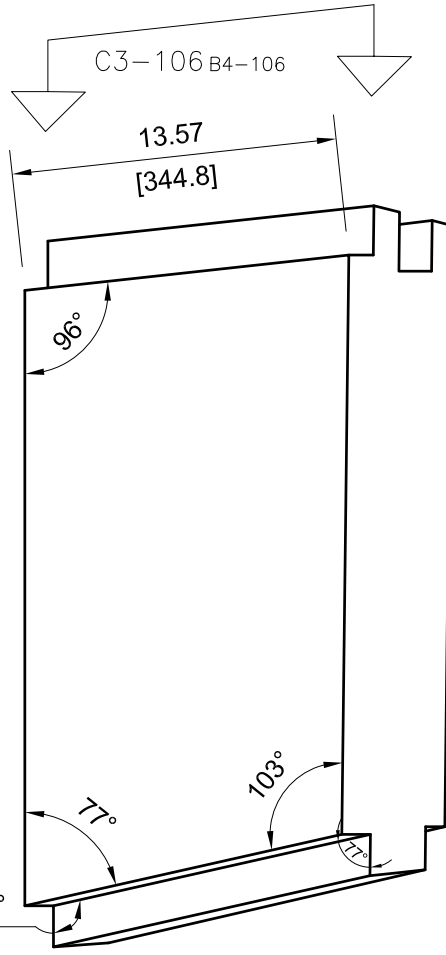
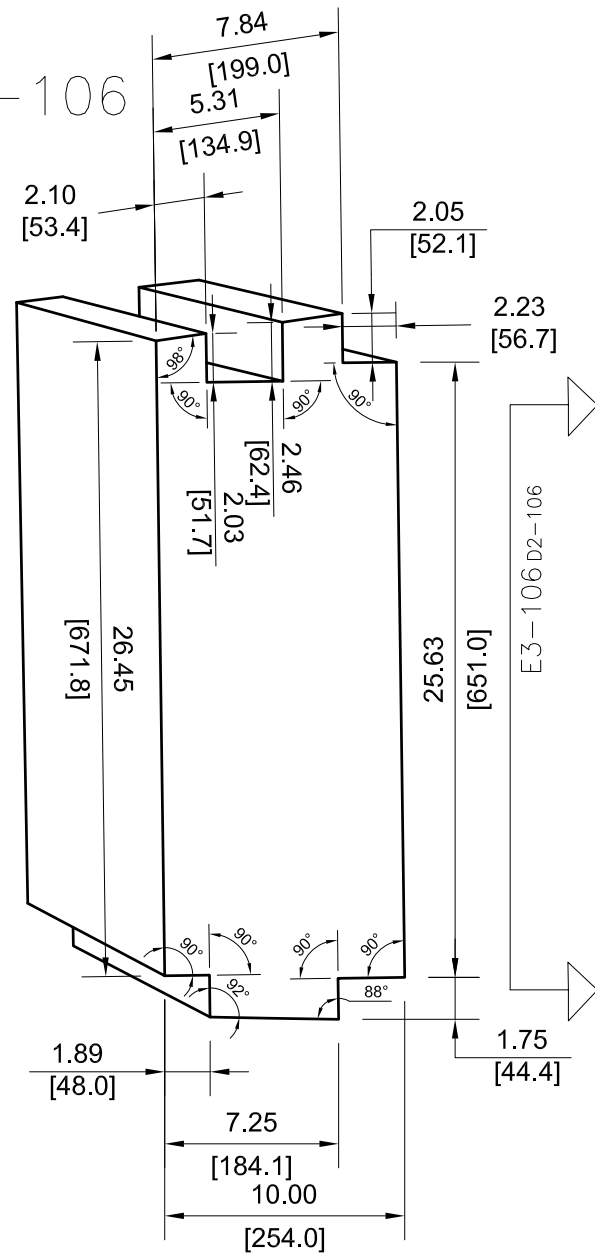

VIEW C7-106

VIEW E4-106

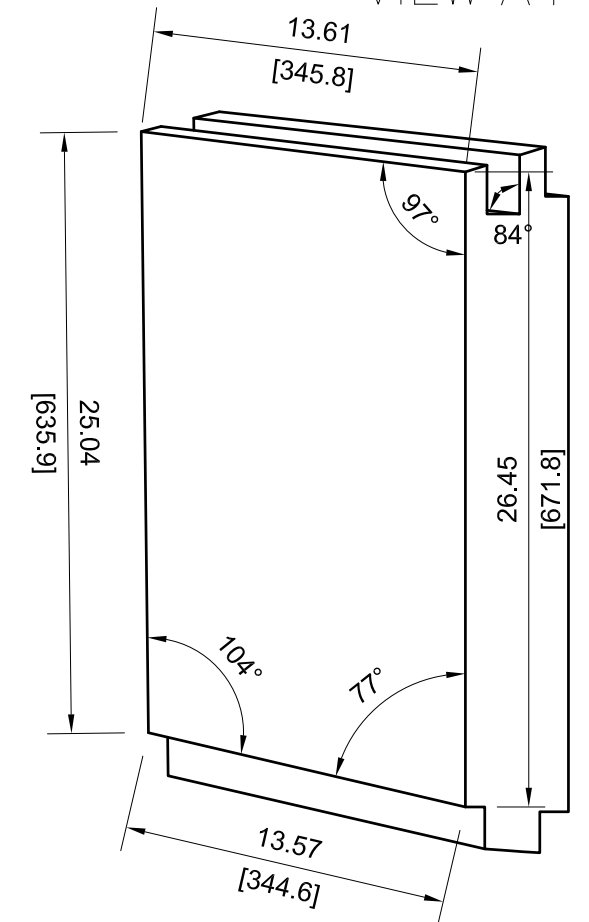
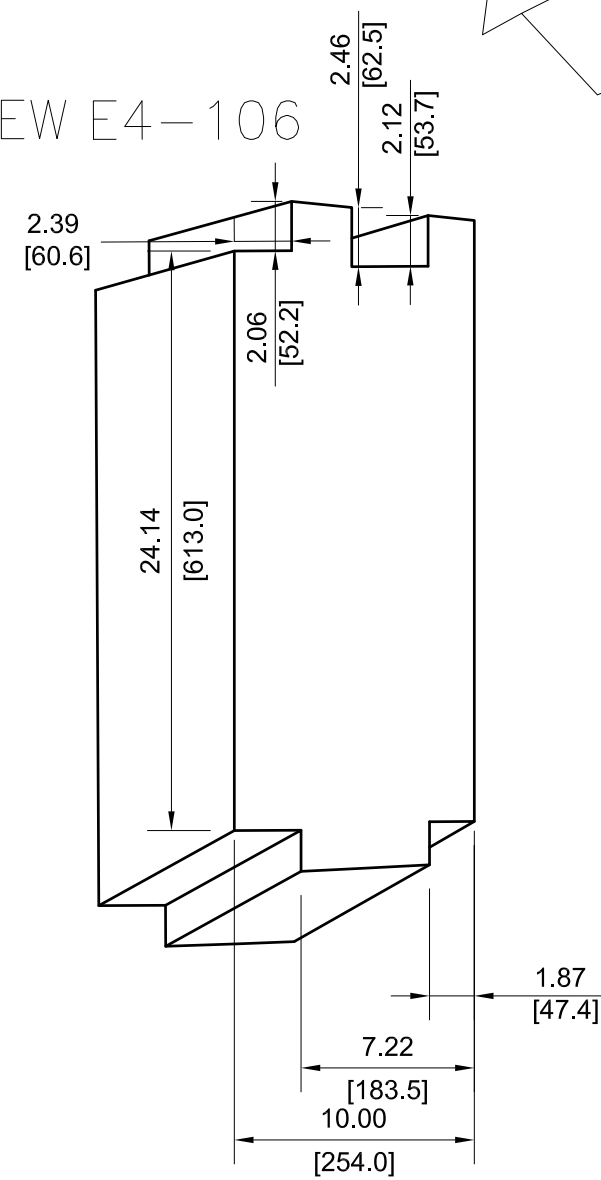

NOTE: ALL VIEWS TAKEN AS TRUE VIEWS PARALLEL TO SURFACE OF PART

DRAWING NUMBER		AES-D0002		
SIZE	SCALE	SHEET	OF	REVISION
A3	NONE	106	167	F

-277

A4-107 D7-107

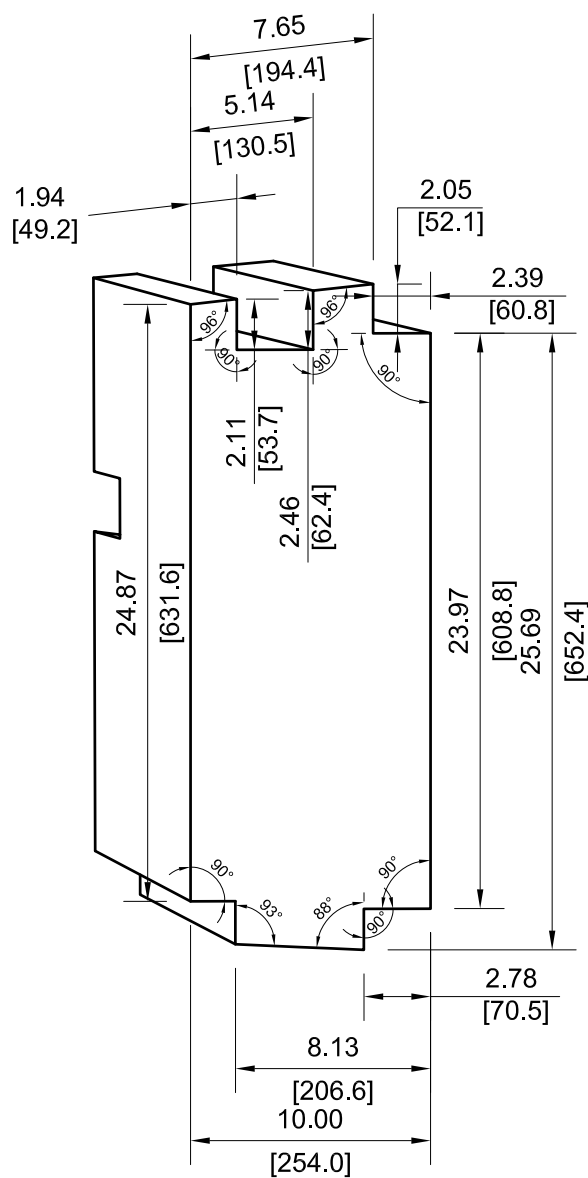
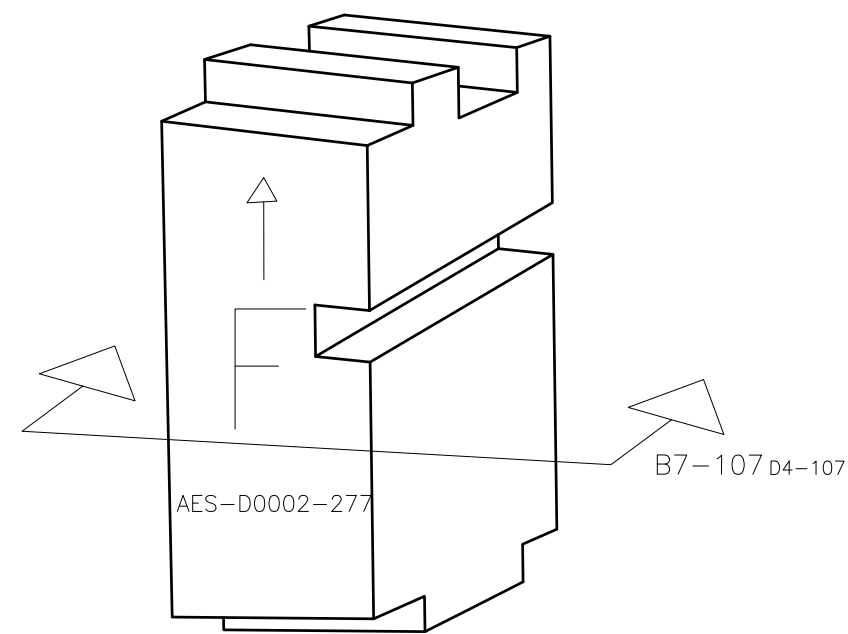
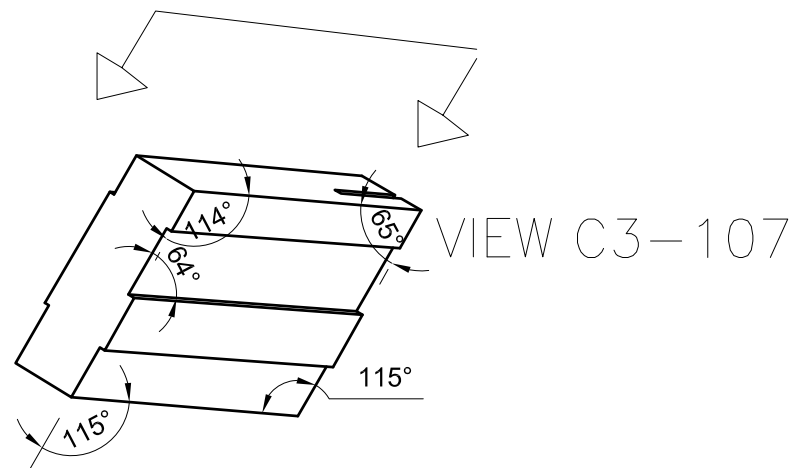

VIEW E3-107

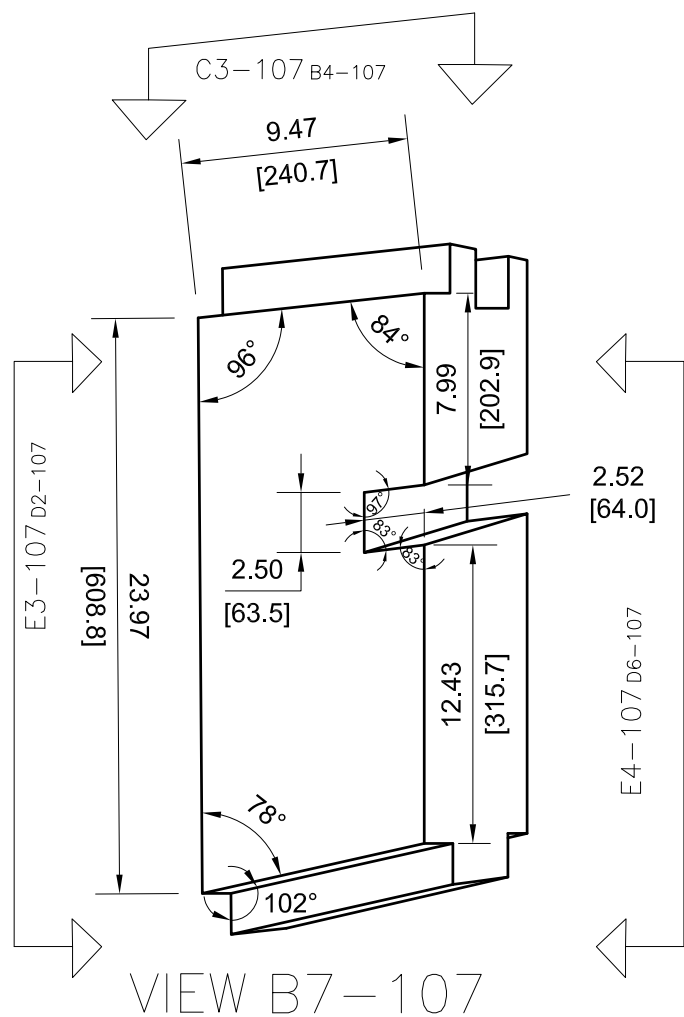

VIEW B7-107

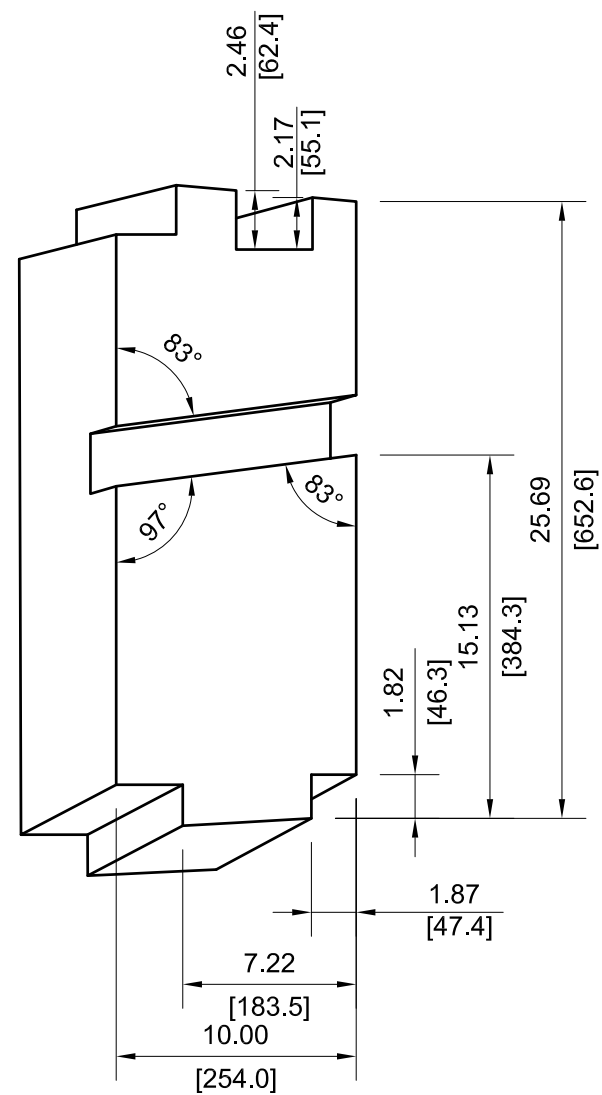

VIEW E4-107

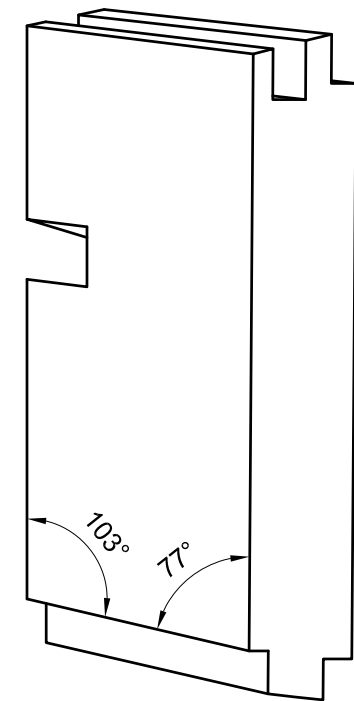

VIEW A4-107

NOTE: ALL VIEWS TAKEN AS TRUE VIEWS PARALLEL TO SURFACE OF PART

		DRAWING NUMBER			
		AES-D0002			
SIZE	SCALE	SHEET	OF	REVISION	
A3	NONE	107	167	F	

-279

A4-108 E7-108

VIEW C3-108

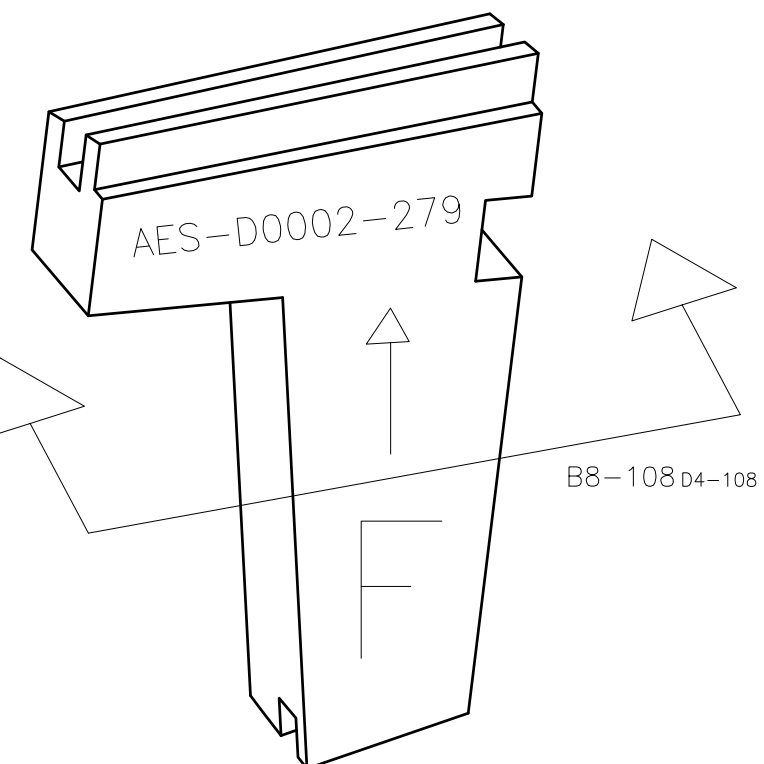
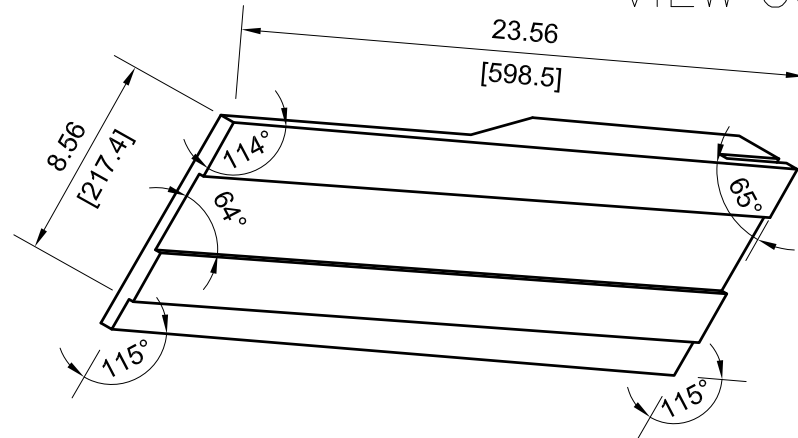

B8-108 D4-108

C3-108 B4-108

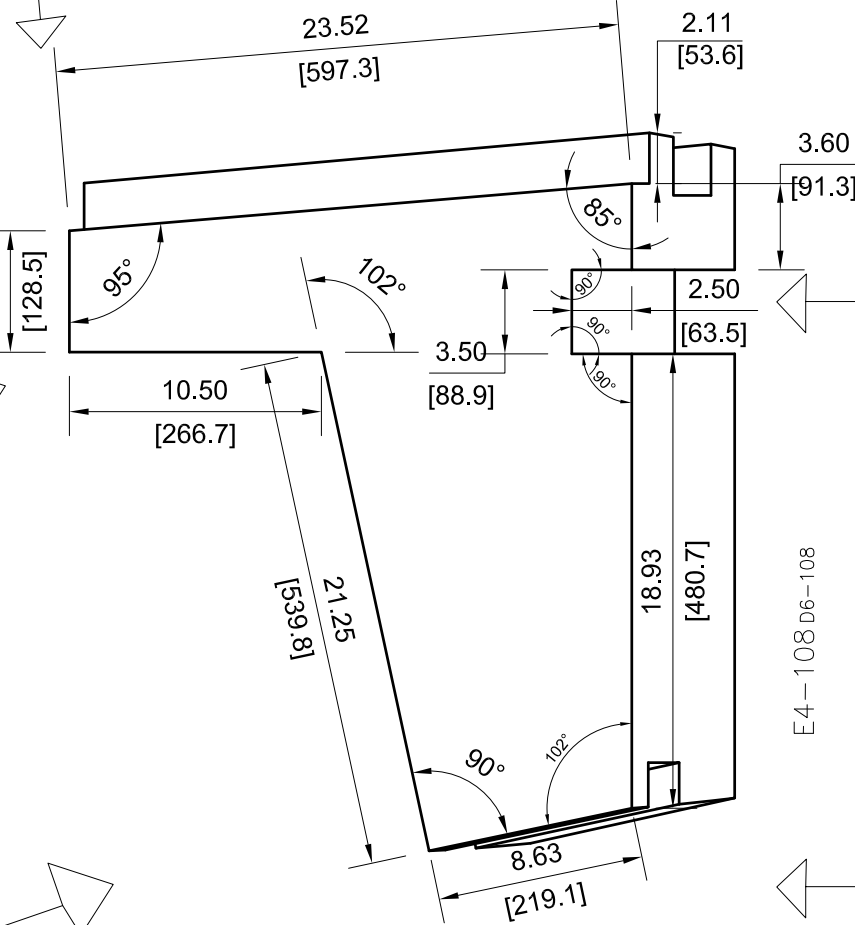

VIEW B8-108

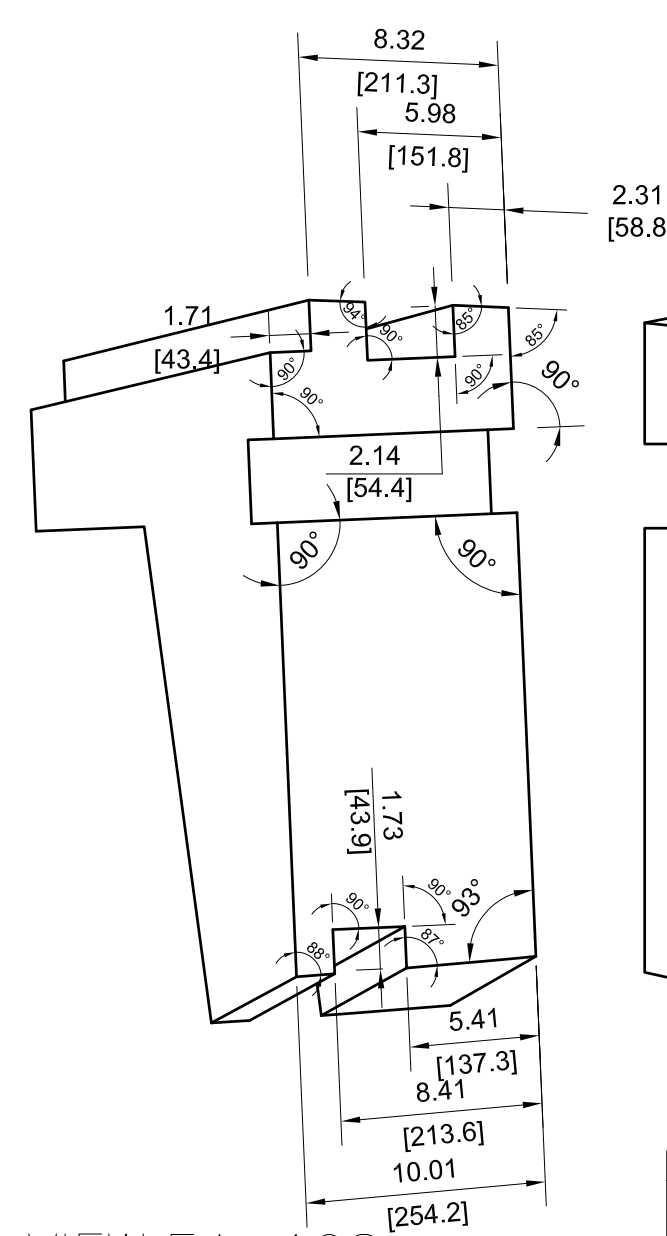

VIEW E4-108

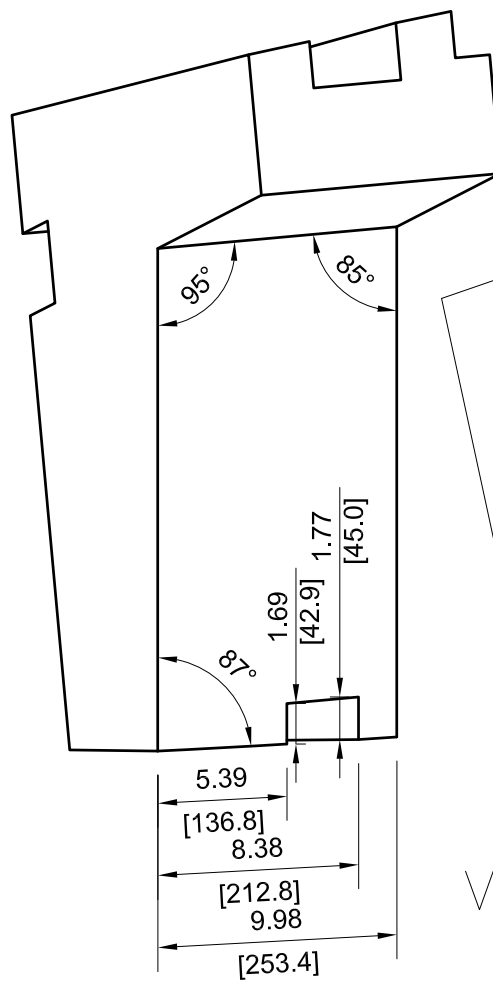

VIEW E2-108

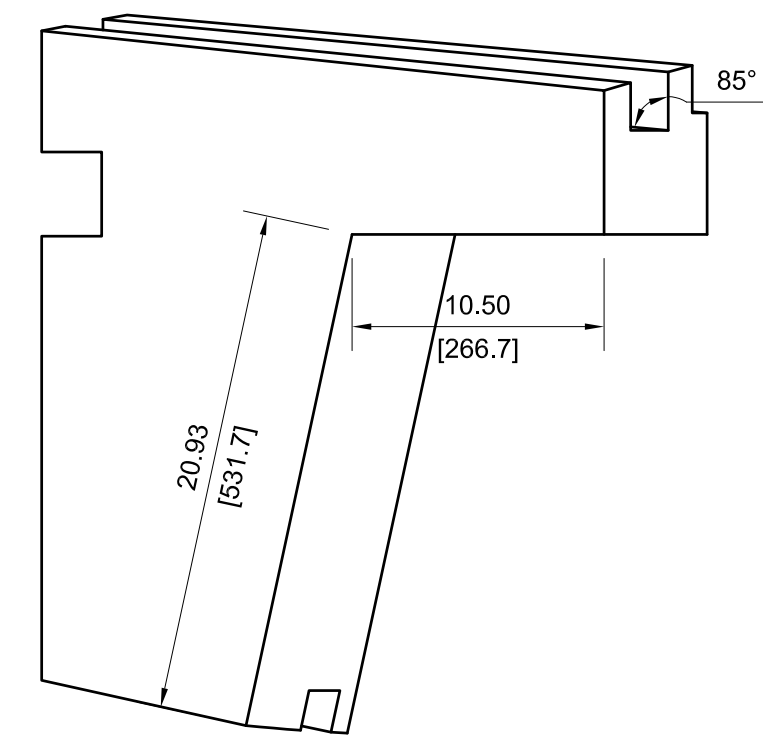

VIEW A4-108

NOTE: ALL VIEWS TAKEN AS TRUE VIEWS PARALLEL TO SURFACE OF PART

		DRAWING NUMBER			
		AES-D0002			
SIZE	SCALE	SHEET	OF	REVISION	
A3	NONE	108	167	F	

-281

VIEW C3-109

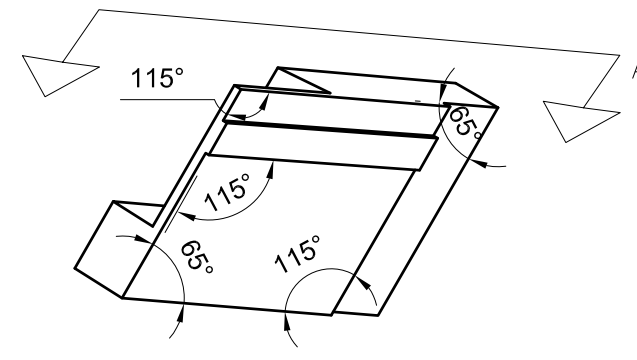

A5-109 D8-109

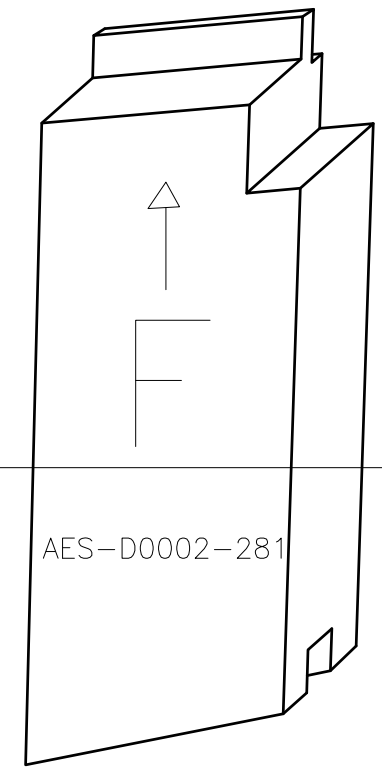

B7-109 D4-109

VIEW E3-109

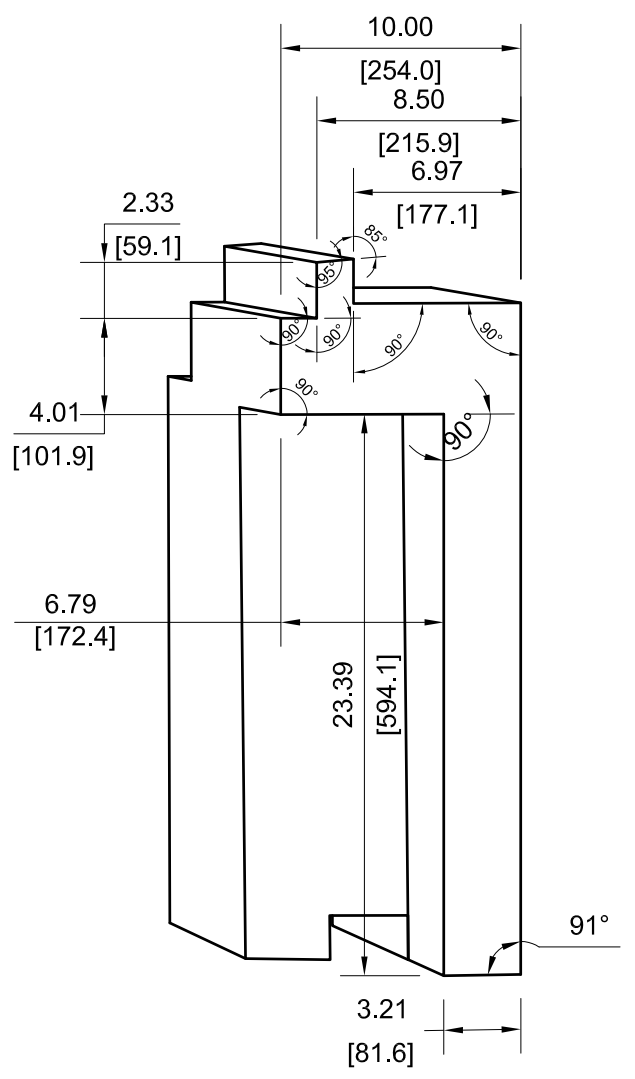

VIEW B7-109

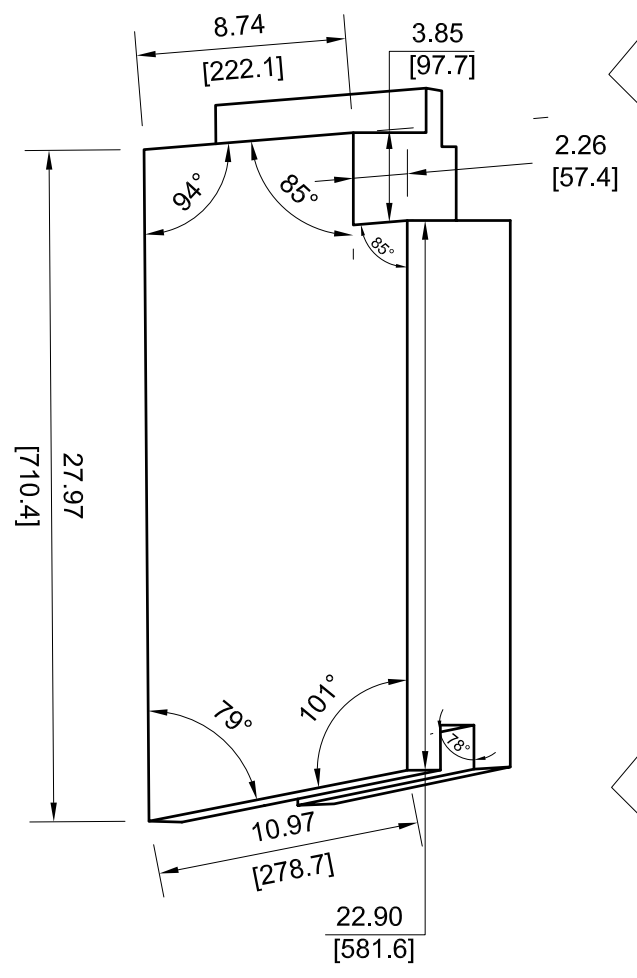

VIEW E5-109

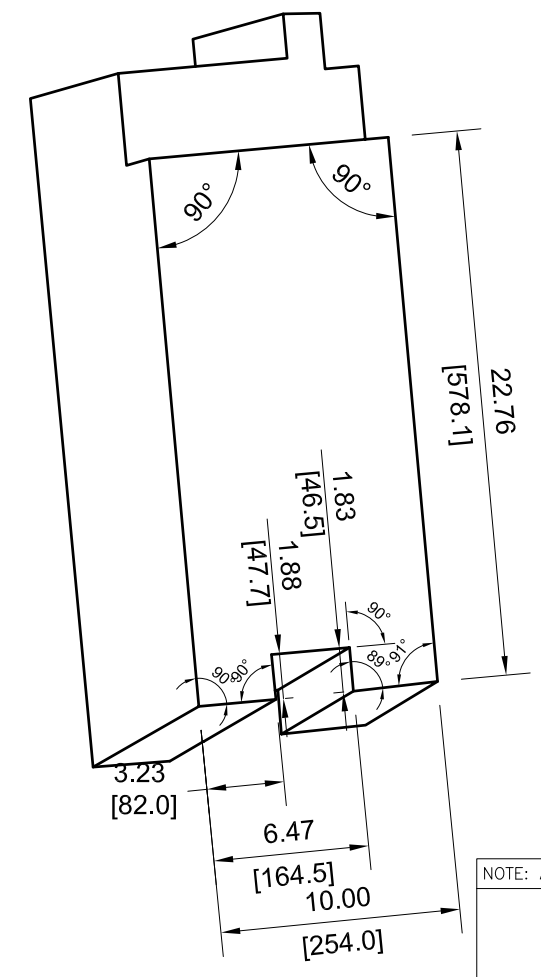

VIEW A5-109

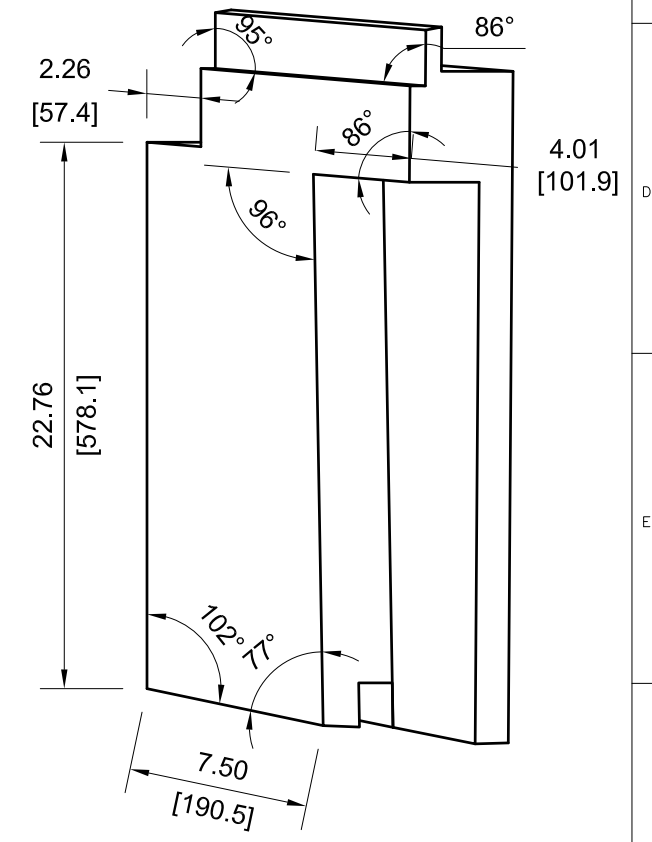

E3-109 D2-109

E5-109 D6-109

NOTE: ALL VIEWS TAKEN AS TRUE VIEWS PARALLEL TO SURFACE OF PART



DRAWING NUMBER				
AES-D0002				
SIZE	SCALE	SHEET	OF	REVISION
A3	NONE	109	167	F

-283

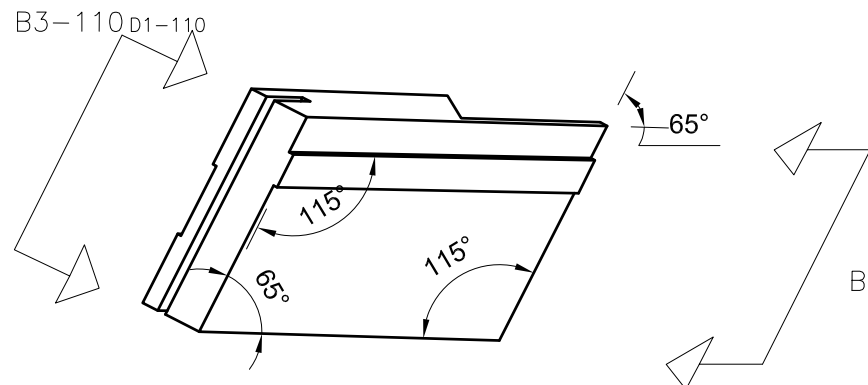

B5-110 D6-110

A6-110 D8-110

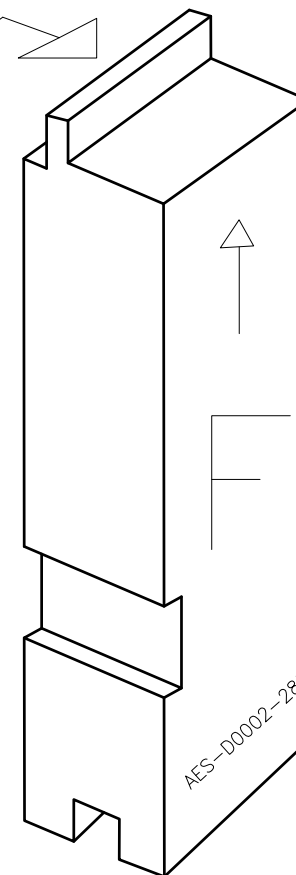

C8-110 D4-110

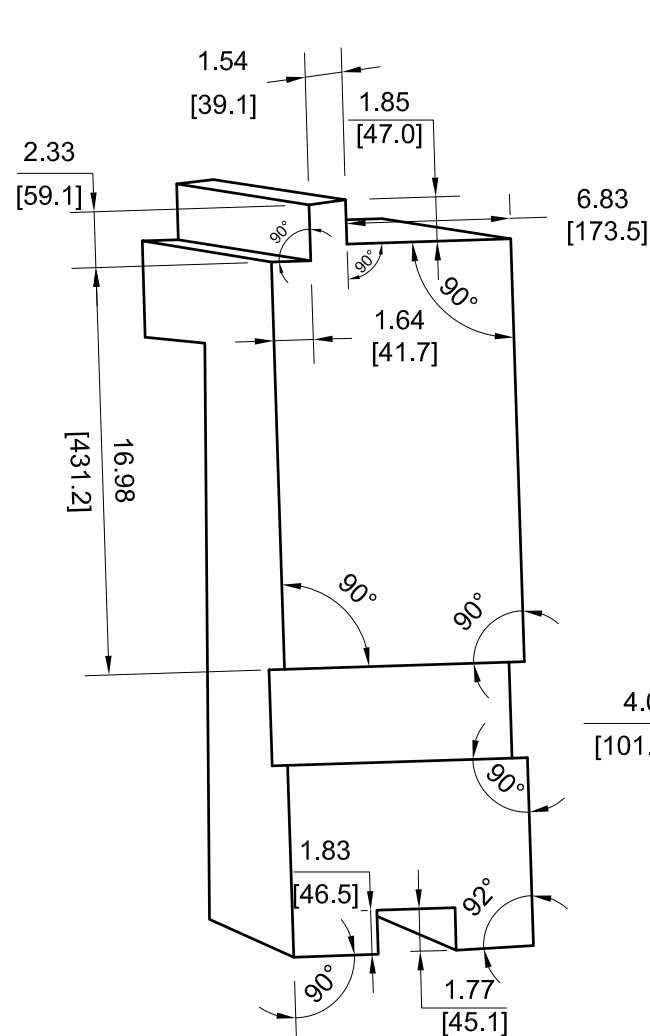

VIEW B3-110

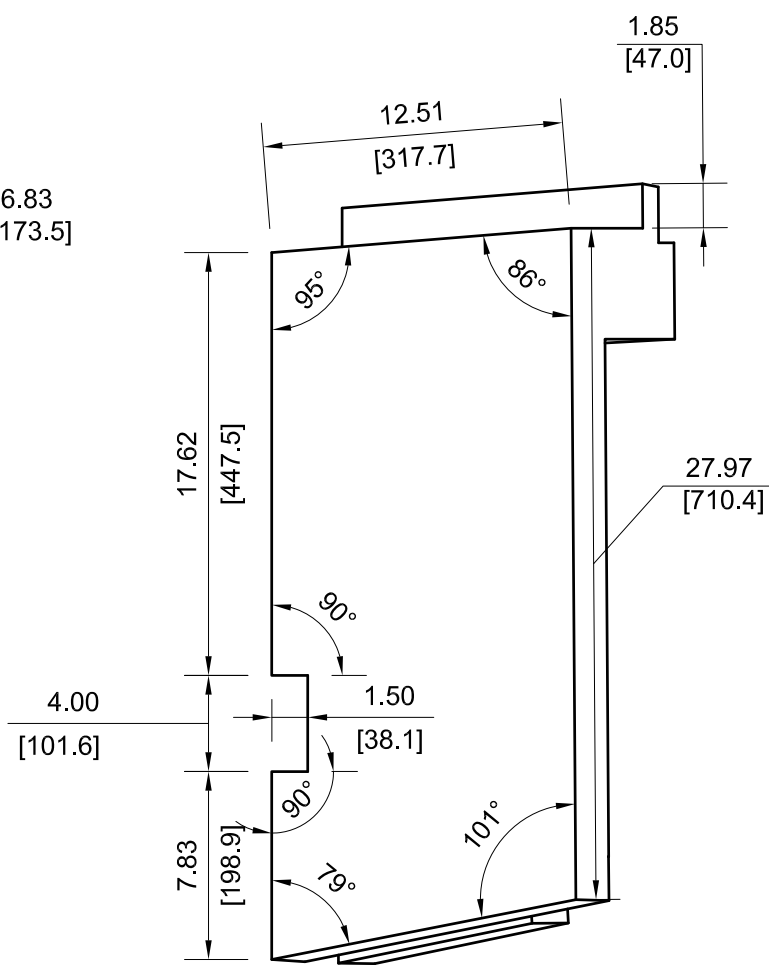

VIEW C8-110

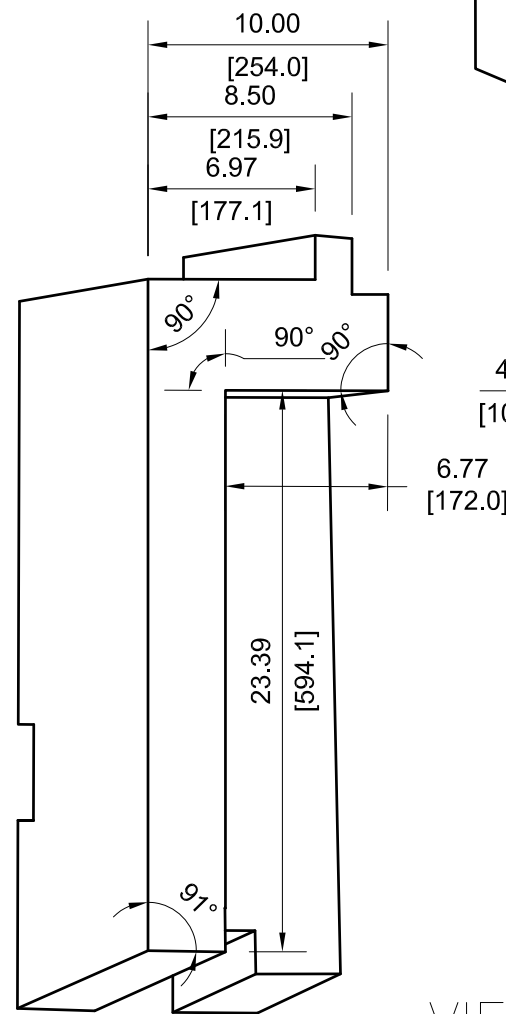

VIEW B5-110

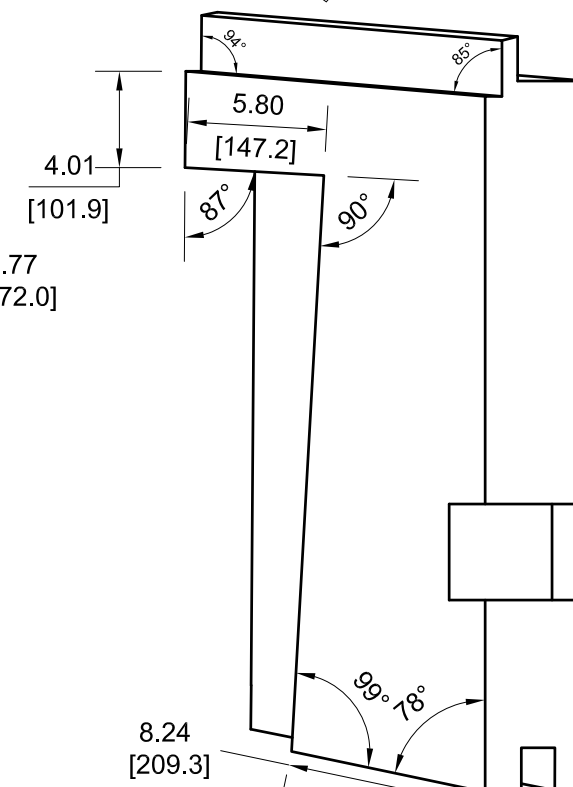

VIEW A6-110

NOTE: ALL VIEWS TAKEN AS TRUE VIEWS PARALLEL TO SURFACE OF PART

		DRAWING NUMBER			
		AES-D0002			
SIZE	SCALE	SHEET	OF	REVISION	
A3	NONE	110	167	F	

-285

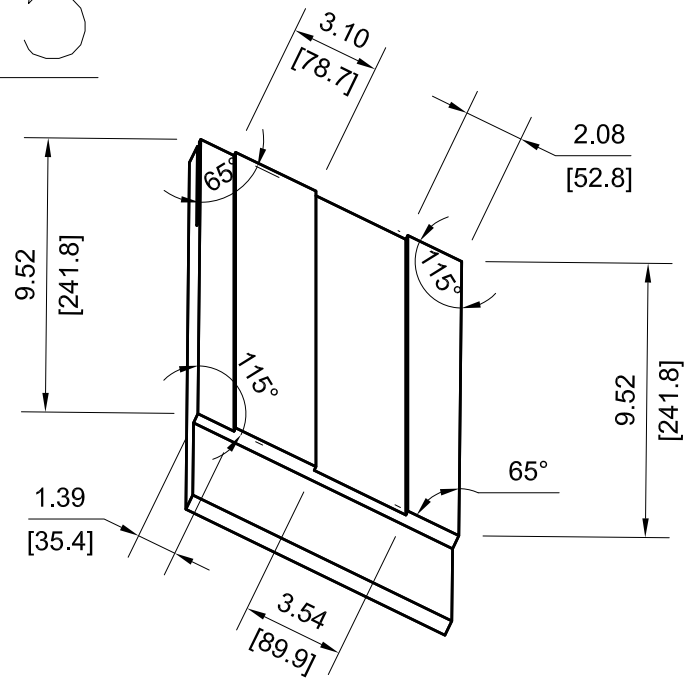

VIEW D4-111

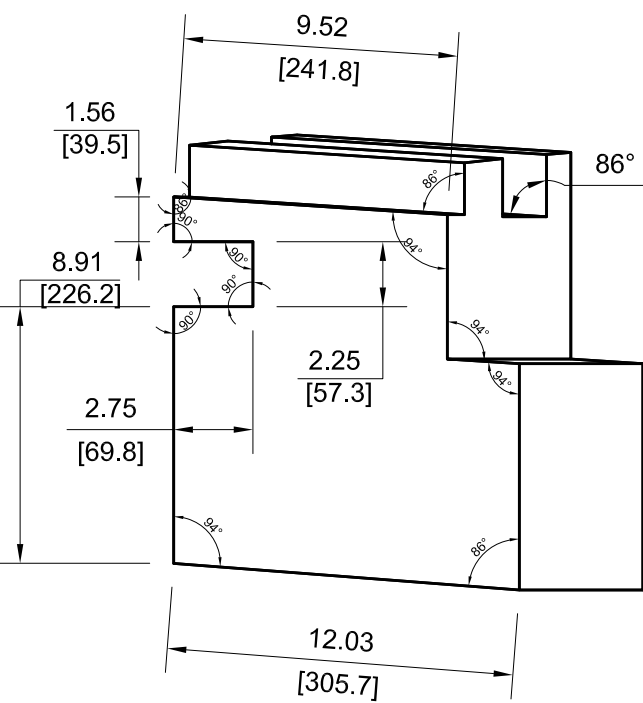
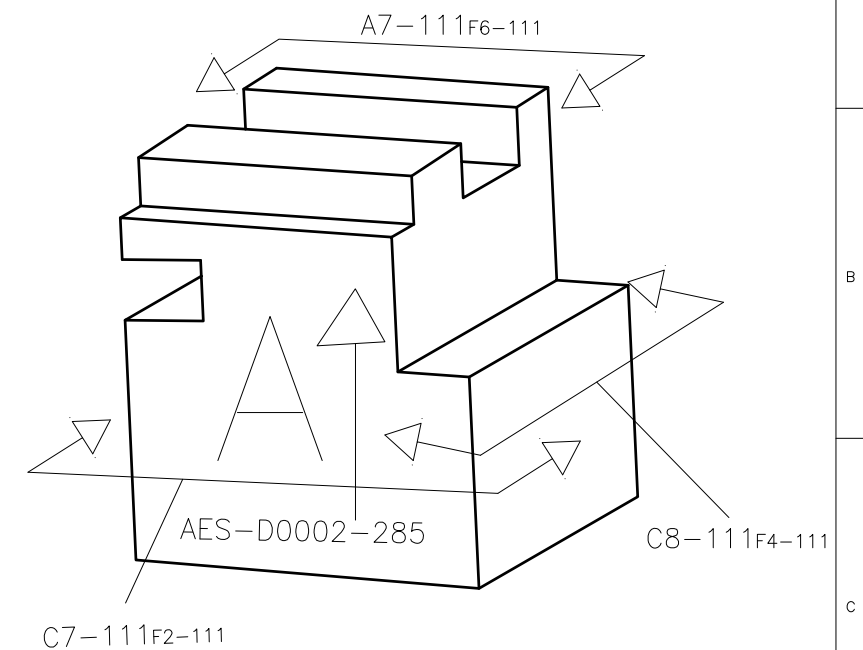

VIEW C7-111

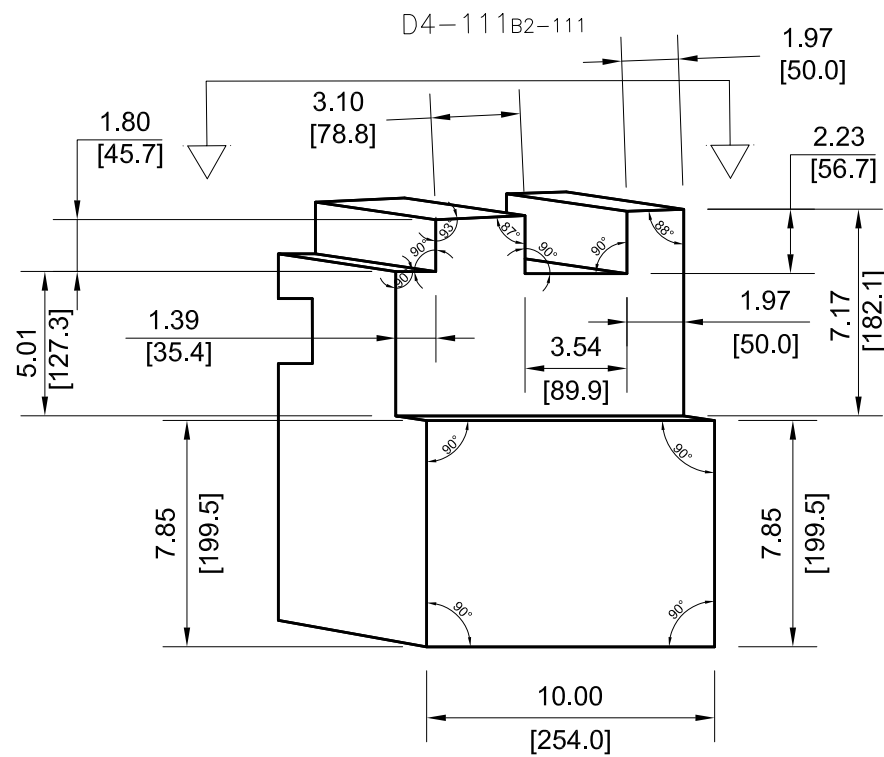

VIEW C8-111

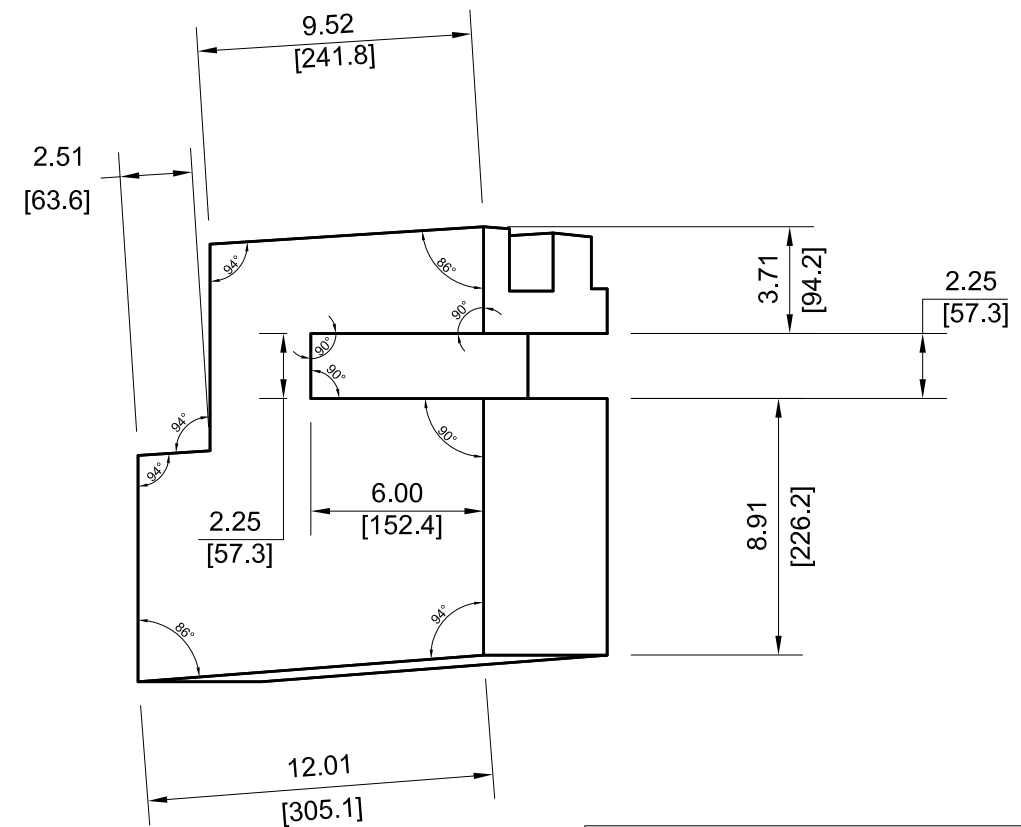

VIEW A7-111

NOTE: ALL VIEWS TAKEN AS TRUE VIEWS PARALLEL TO SURFACE OF PART

		DRAWING NUMBER			
		AES-D0002			
SIZE	SCALE	SHEET	OF	REVISION	
A3	NONE	111	167	F	

-287

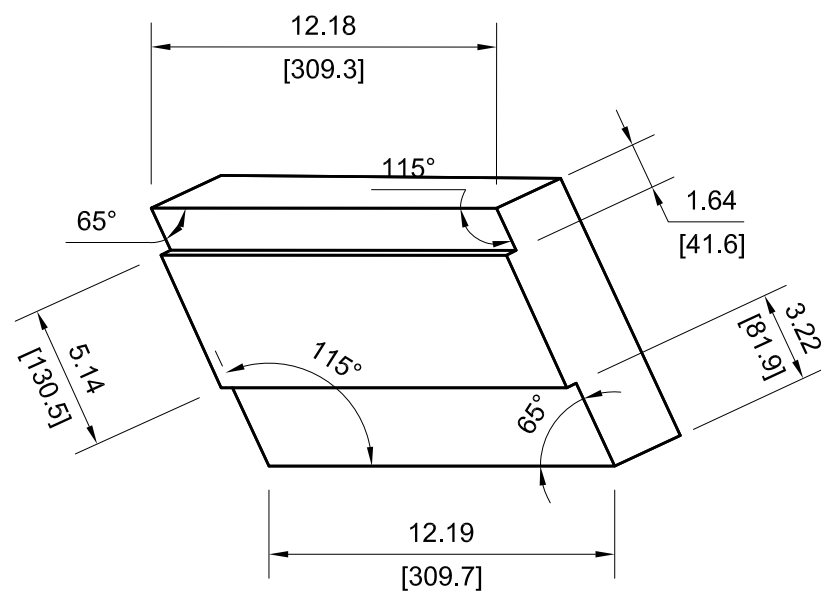

VIEW F4-112

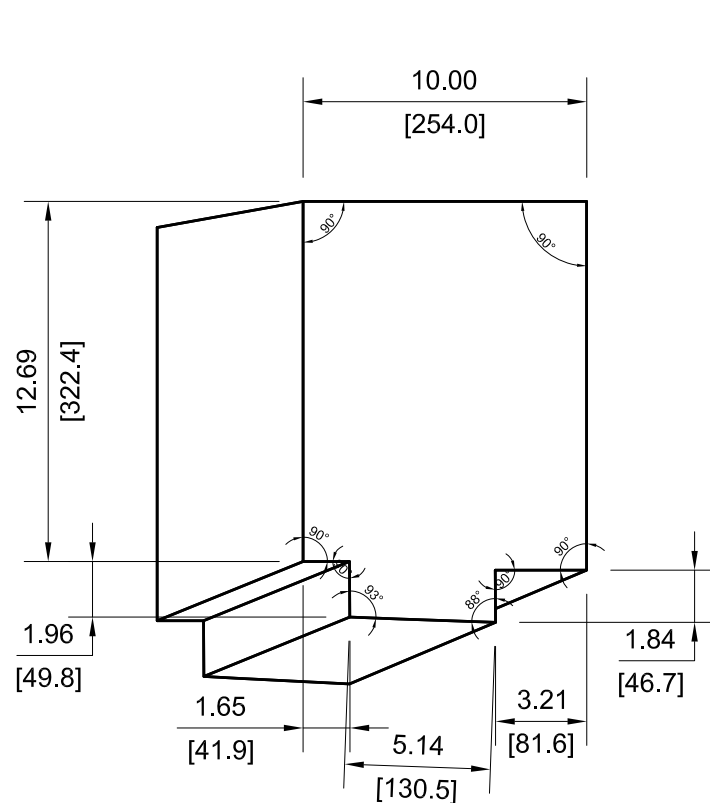
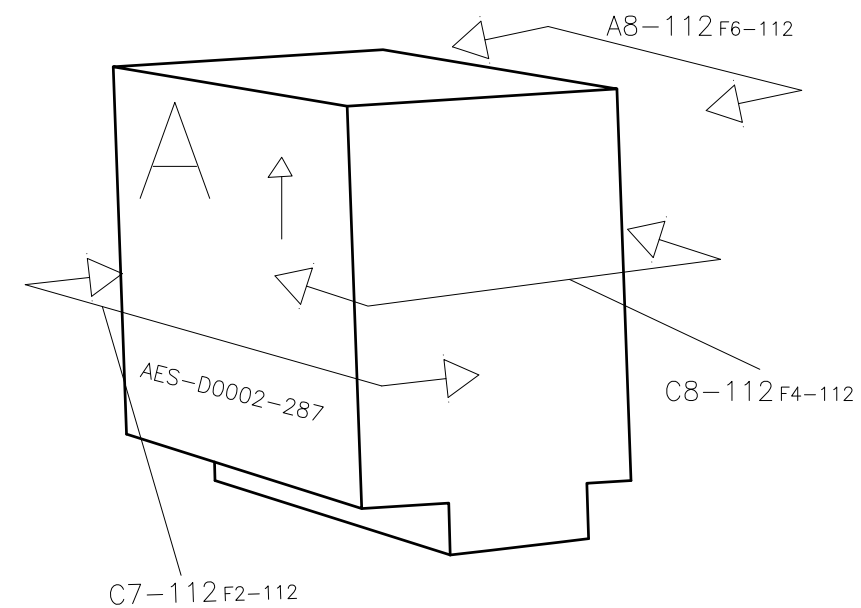

VIEW C8-112

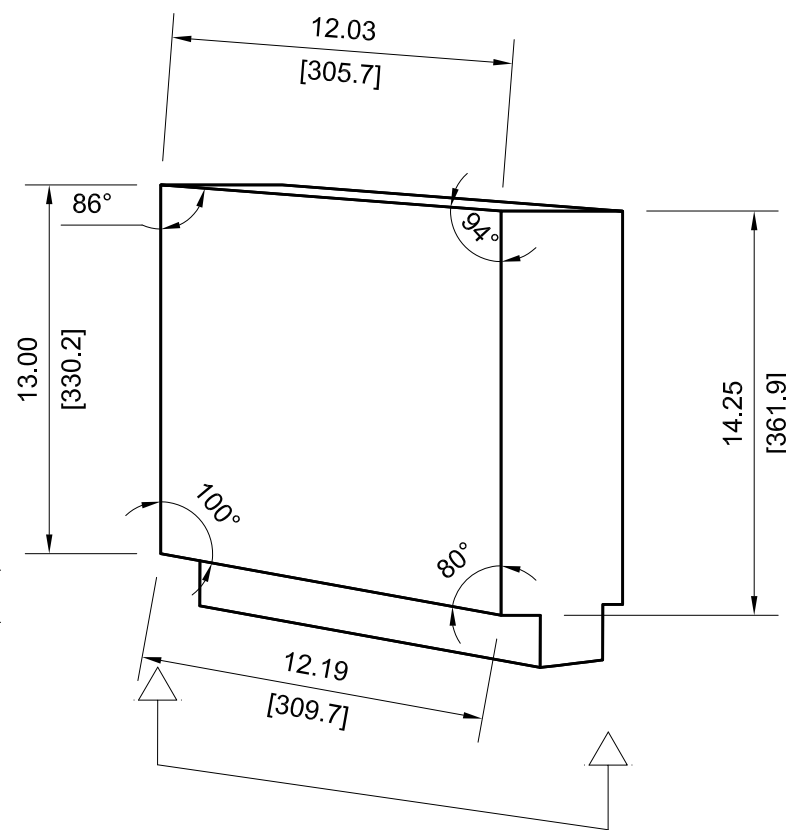

F4-112 C5-112
VIEW C7-112

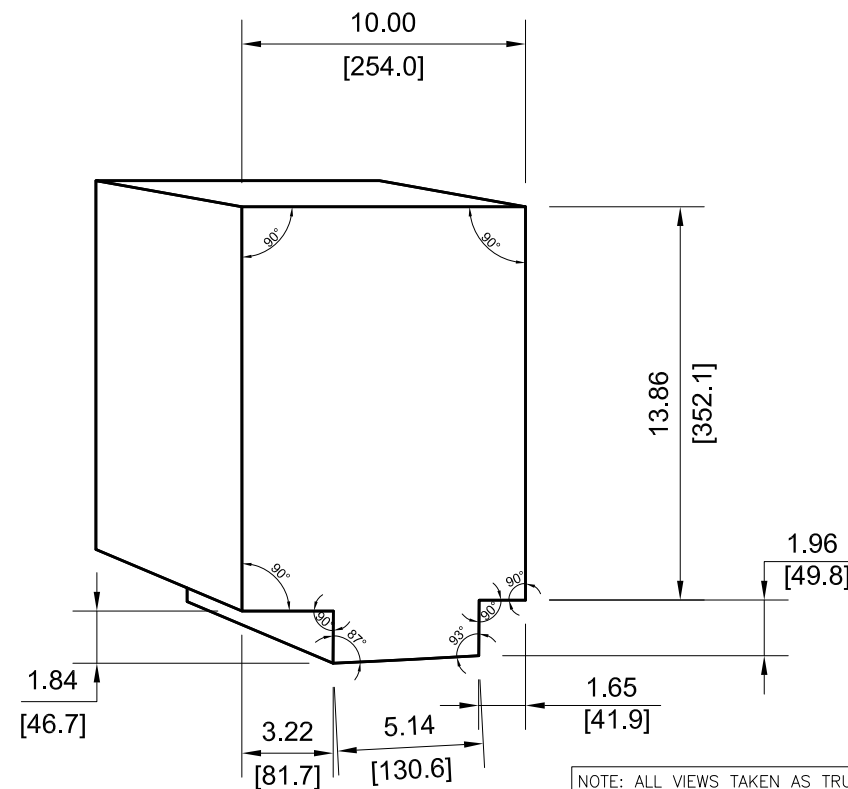

VIEW A8-112

NOTE: ALL VIEWS TAKEN AS TRUE VIEWS PARALLEL TO SURFACE OF PART

		DRAWING NUMBER			
		AES-D0002			
SIZE	SCALE	SHEET	OF	REVISION	
A3	NONE	112	167	F	

-289

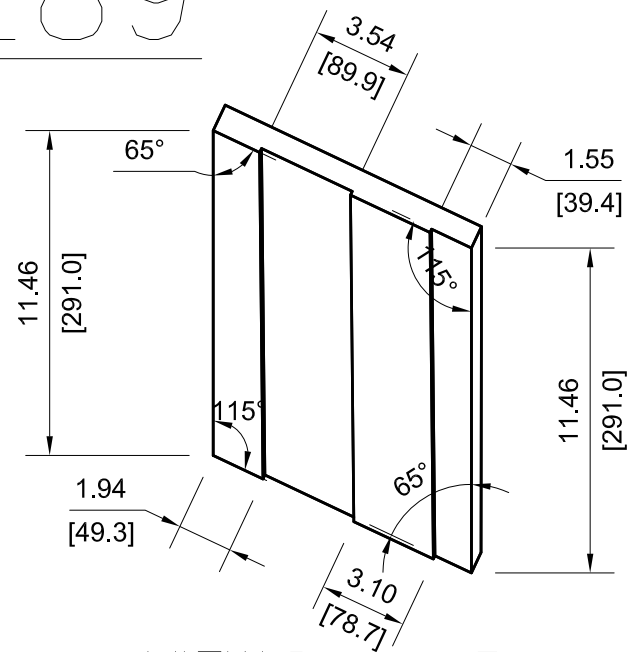

VIEW D4-113

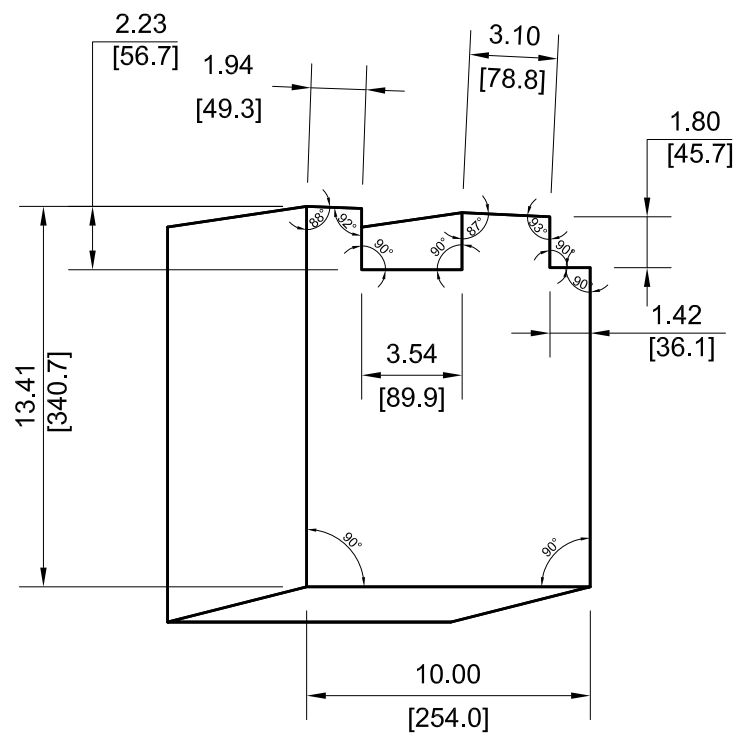
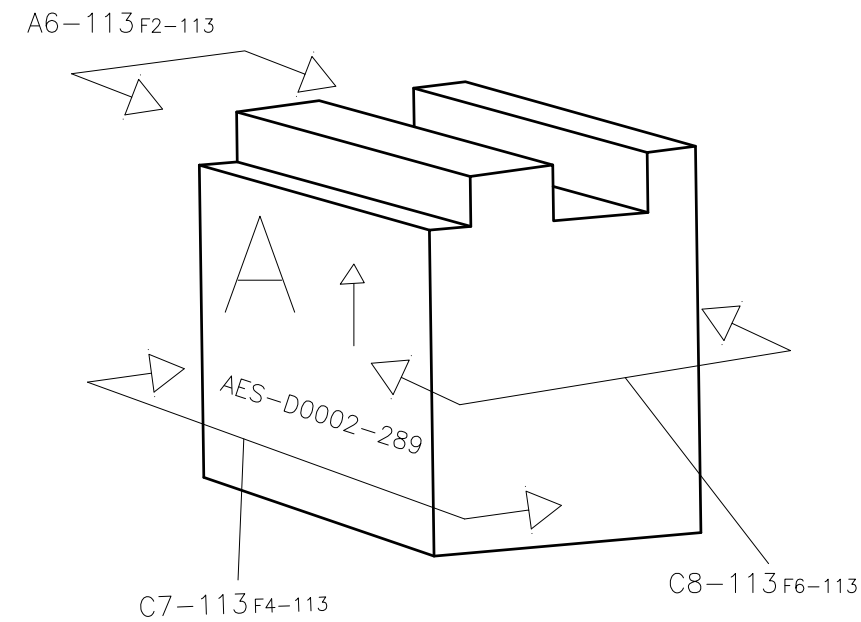

VIEW A7-113

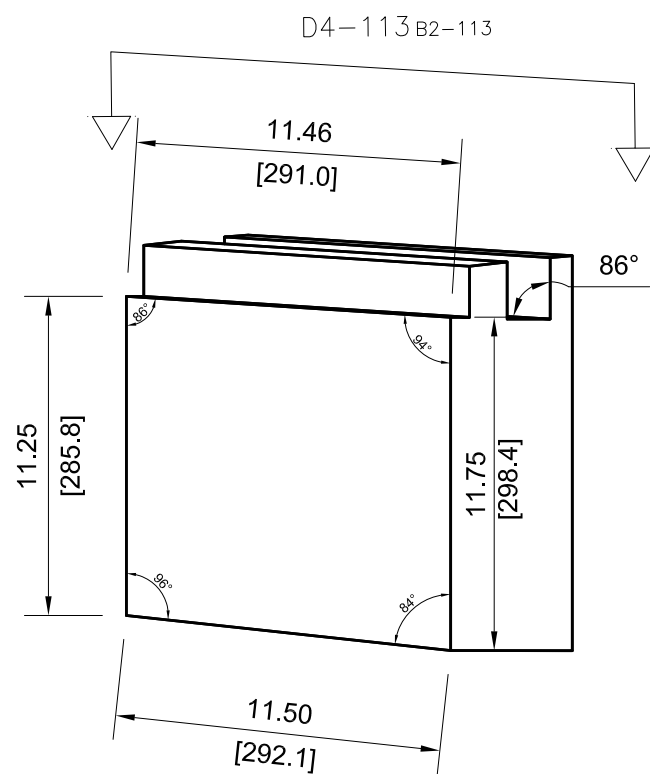

VIEW C7-113

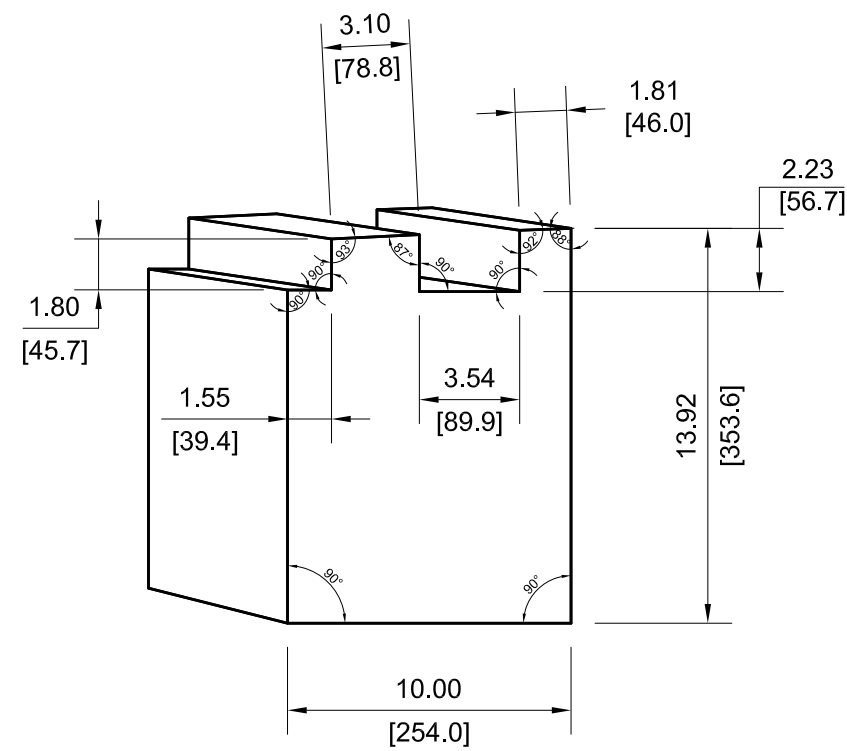

VIEW C8-113

NOTE: ALL VIEWS TAKEN AS TRUE VIEWS PARALLEL TO SURFACE OF PART

		DRAWING NUMBER			
		AES-D0002			
SIZE	SCALE	SHEET	OF	REVISION	
A3	NONE	113	167	F	

- 291

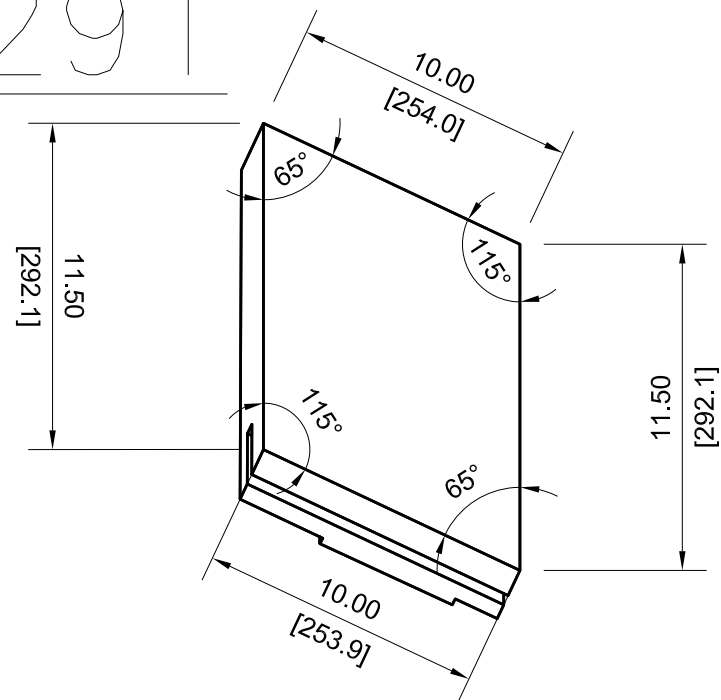

VIEW D4-114

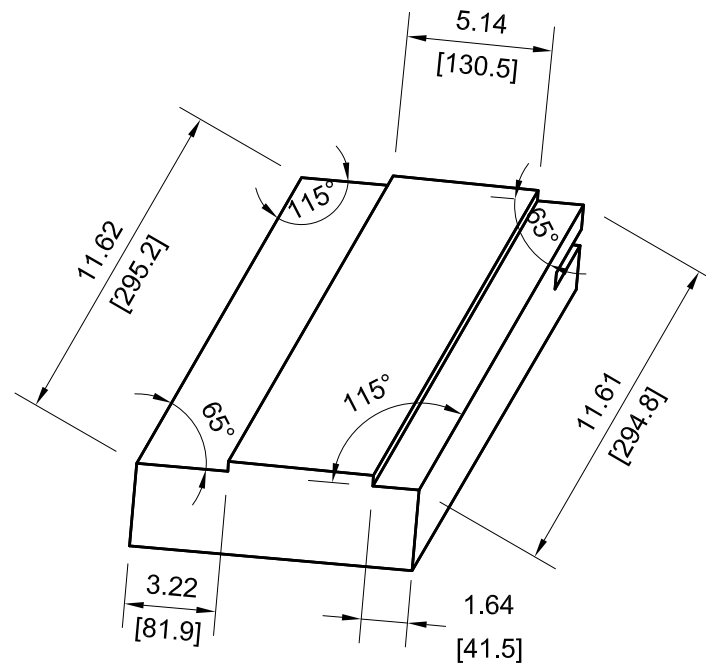

VIEW F4-114

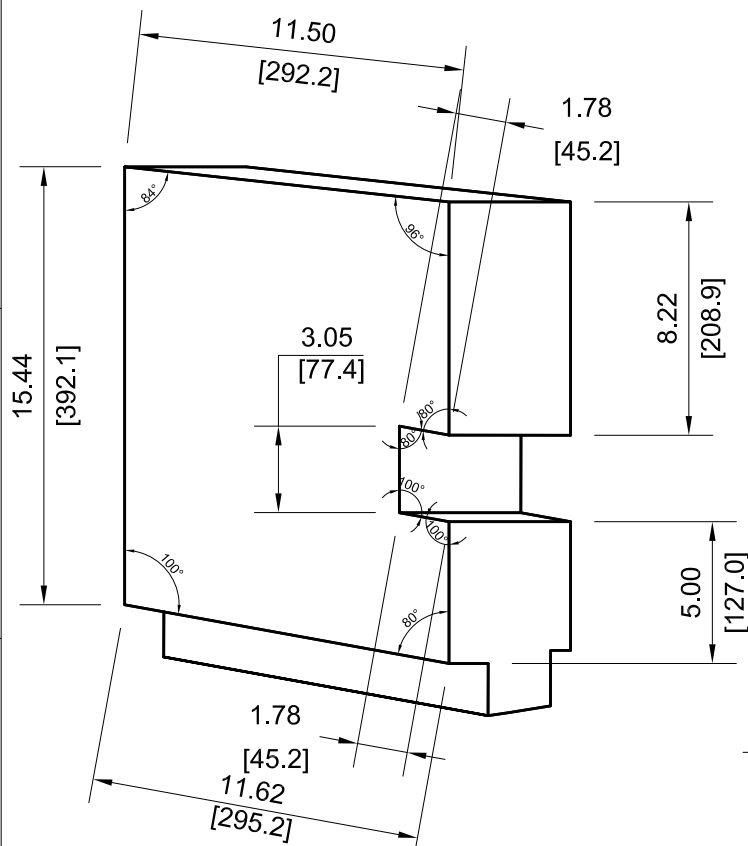
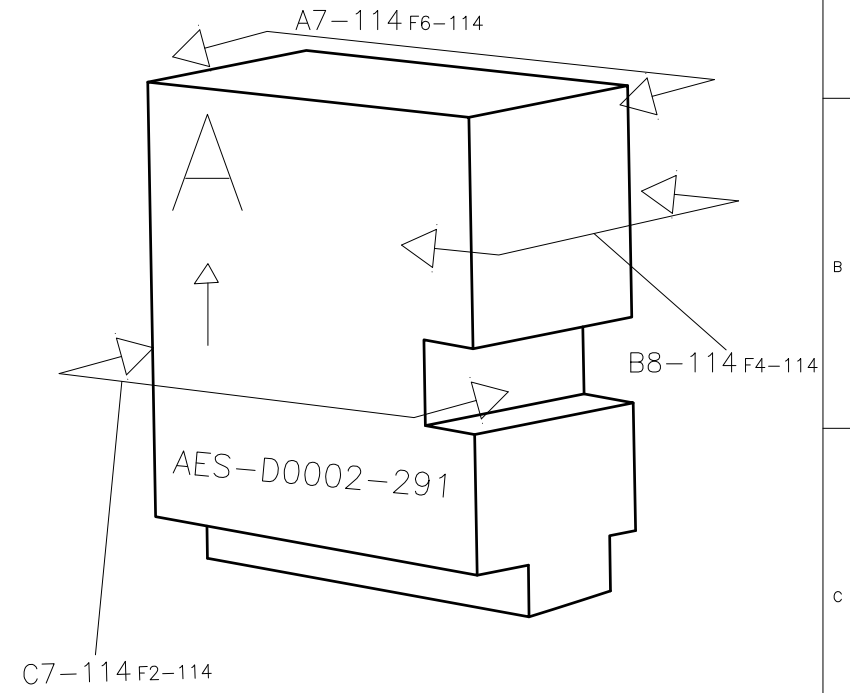

VIEW C7-114

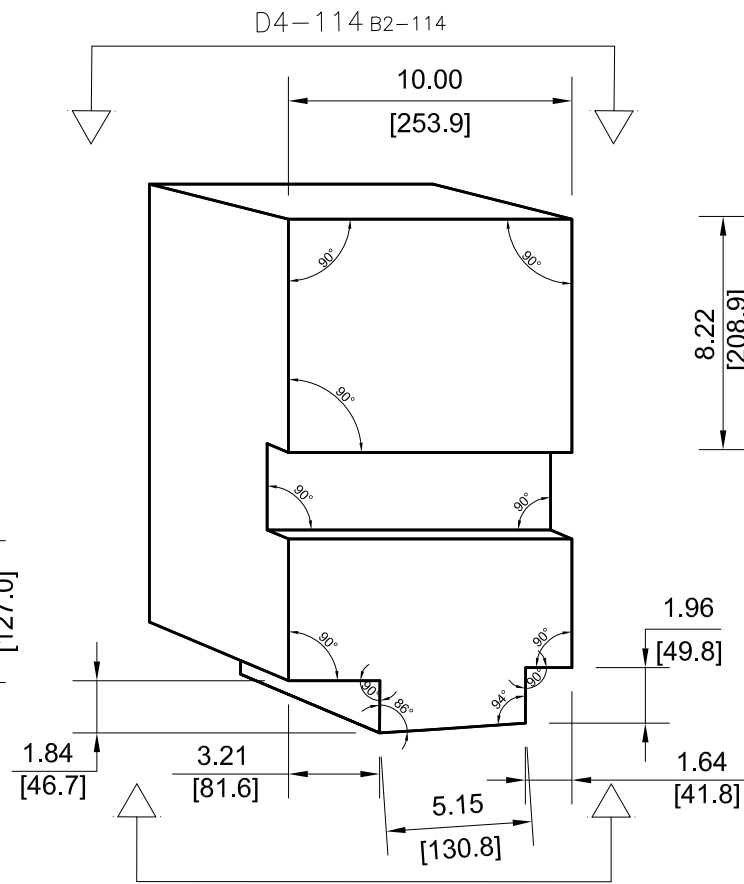

VIEW B8-114

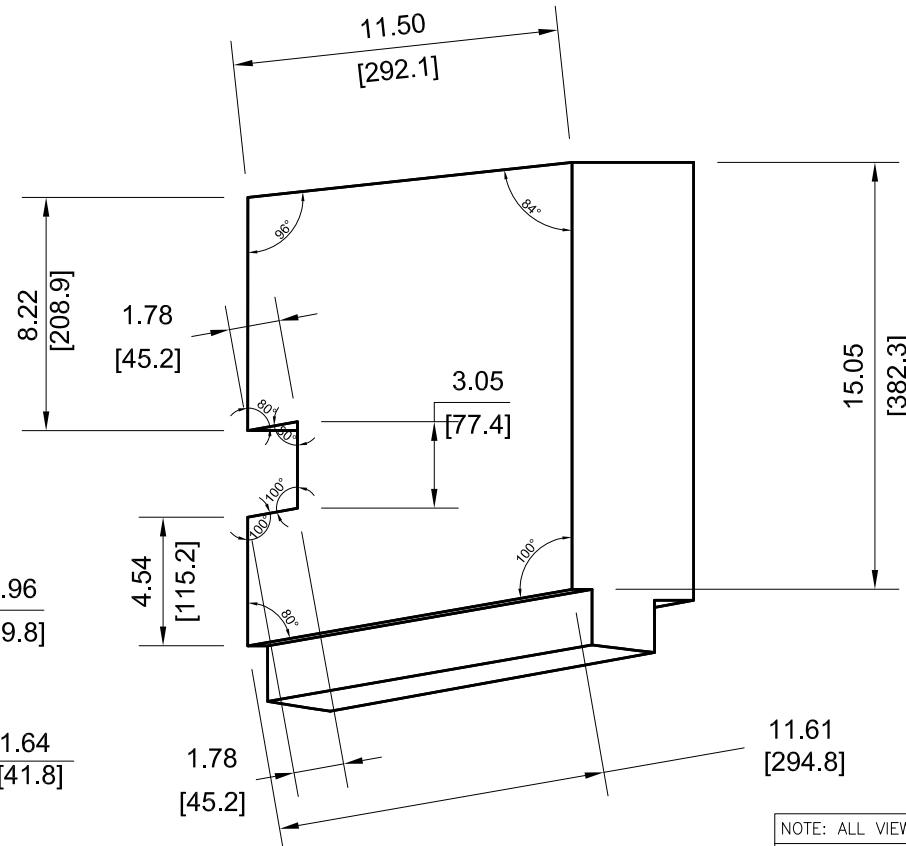

VIEW A7-114

NOTE: ALL VIEWS TAKEN AS TRUE VIEWS PARALLEL TO SURFACE OF PART

		DRAWING NUMBER			
		AES-D0002			
SIZE	SCALE	SHEET	OF	REVISION	
A3	NONE	114	167	F	

-293

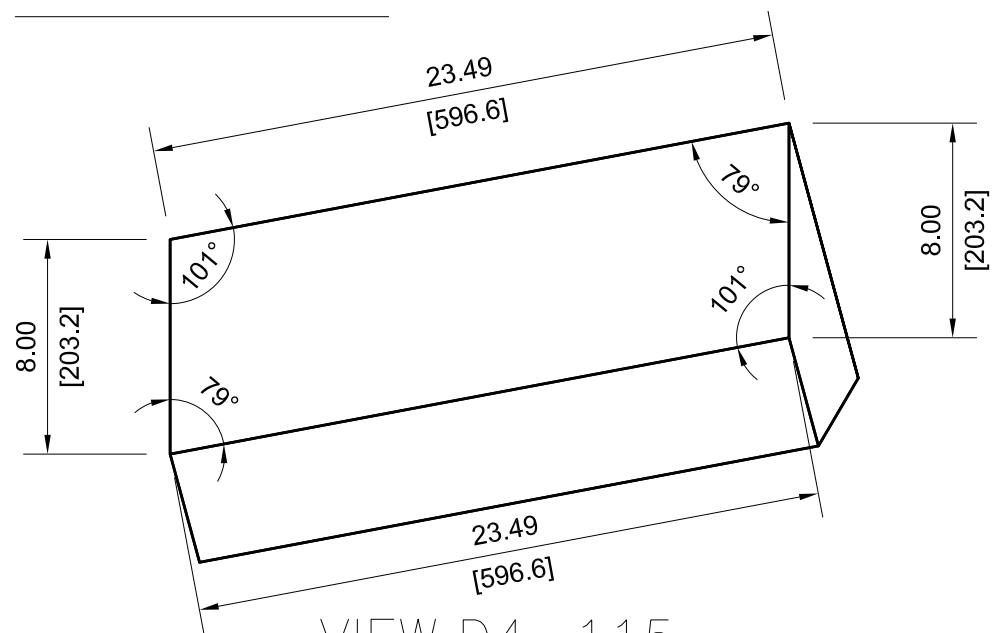

VIEW D4-115

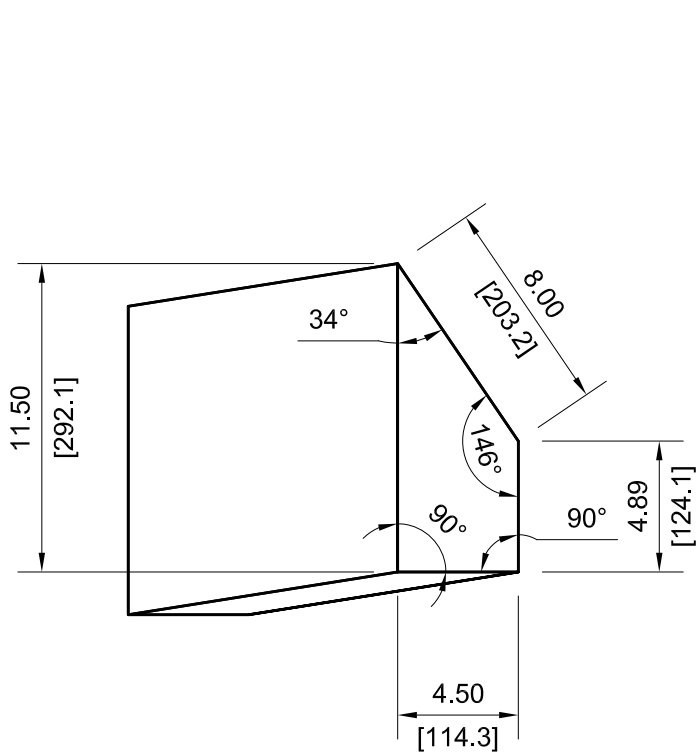
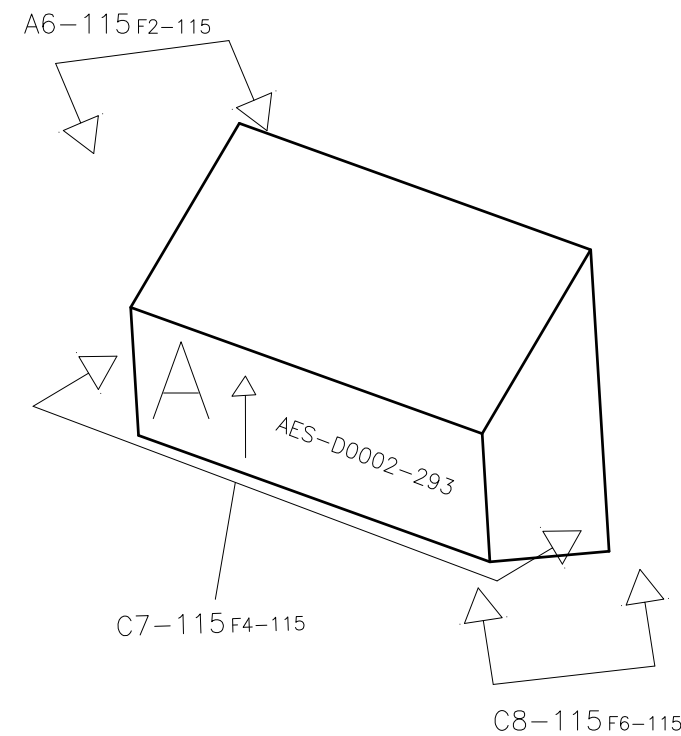

VIEW A6-115

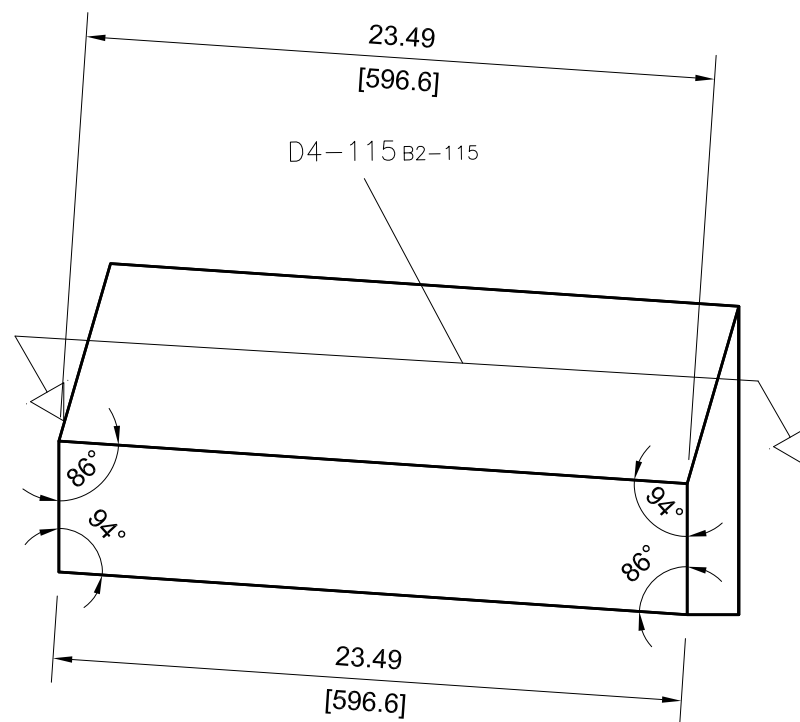

VIEW C7-115

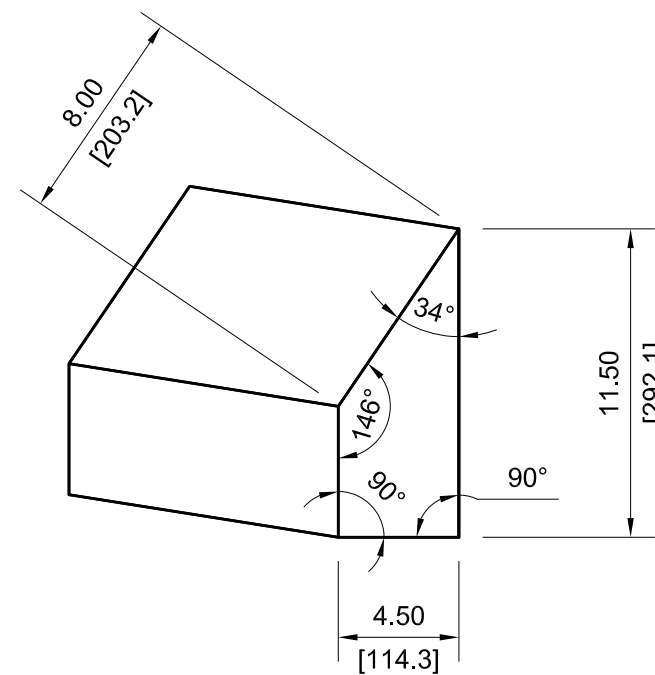

VIEW C8-115

NOTE: ALL VIEWS TAKEN AS TRUE VIEWS PARALLEL TO SURFACE OF PART

		DRAWING NUMBER			
		AES-D0002			
SIZE	SCALE	SHEET	OF	REVISION	
A3	NONE	115	167	F	

-295

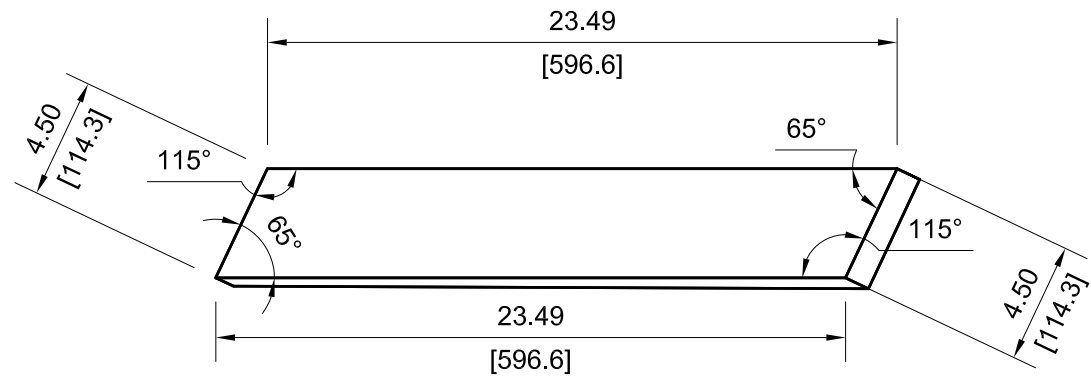

VIEW D4-116

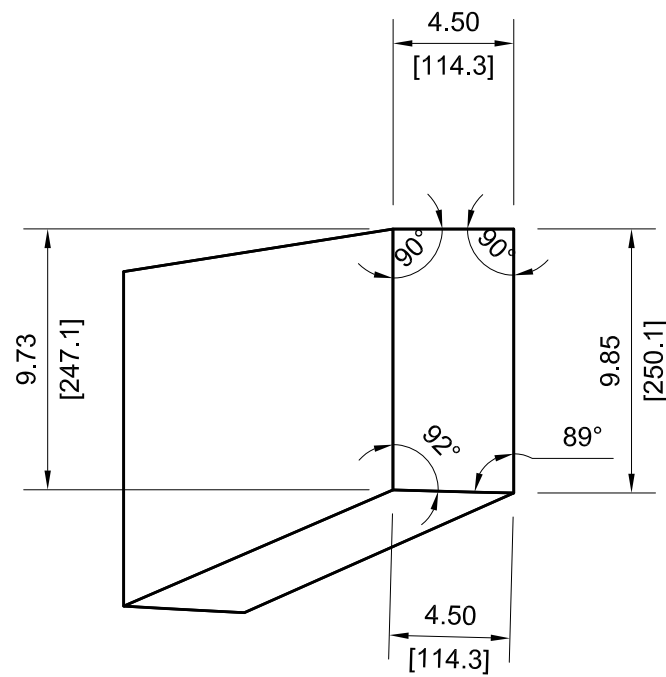
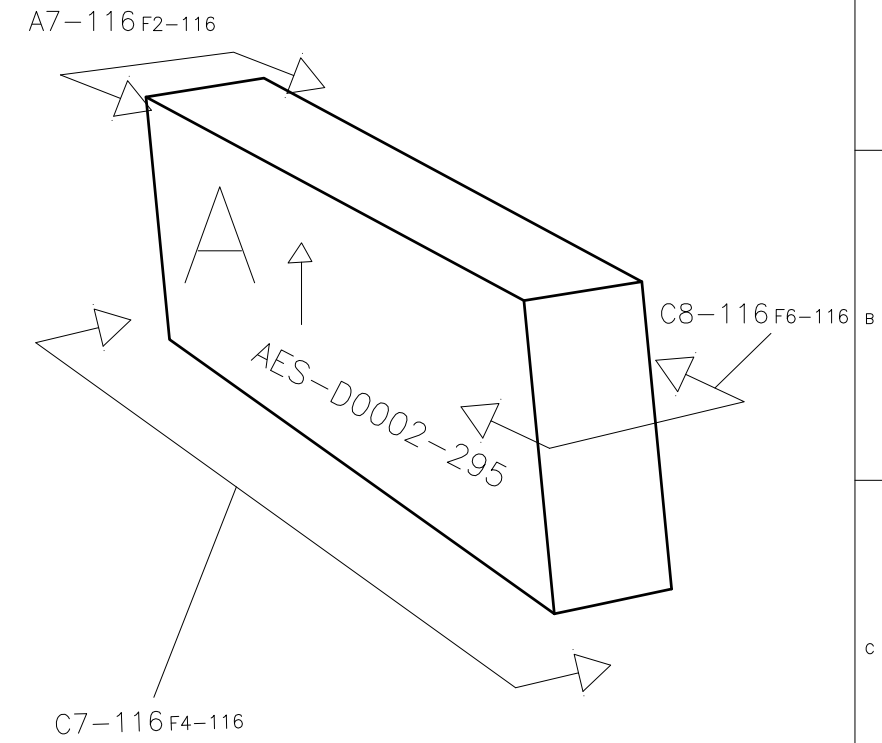

VIEW A7-116

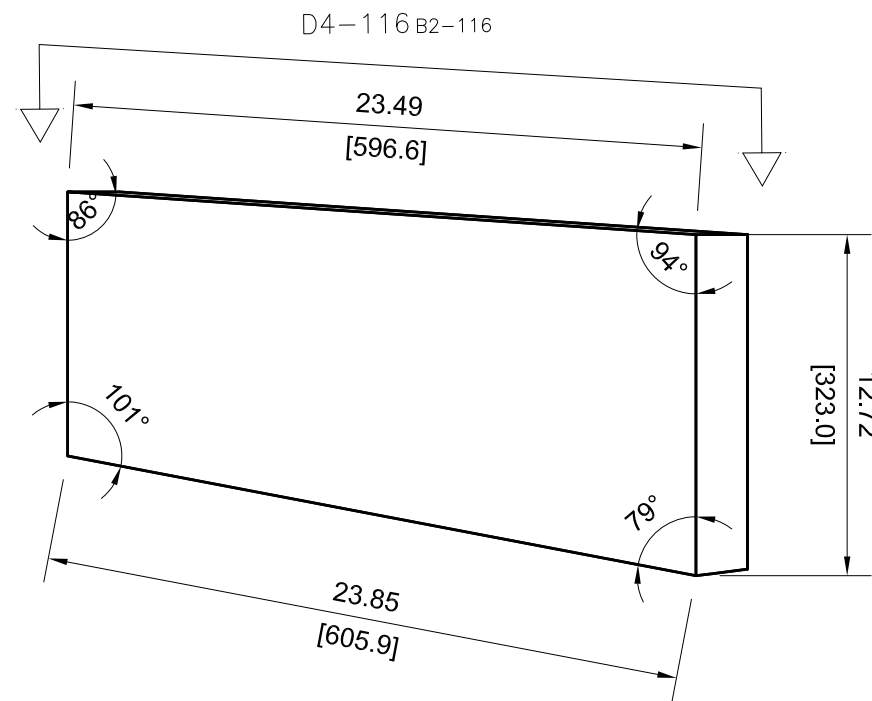

VIEW C7-116

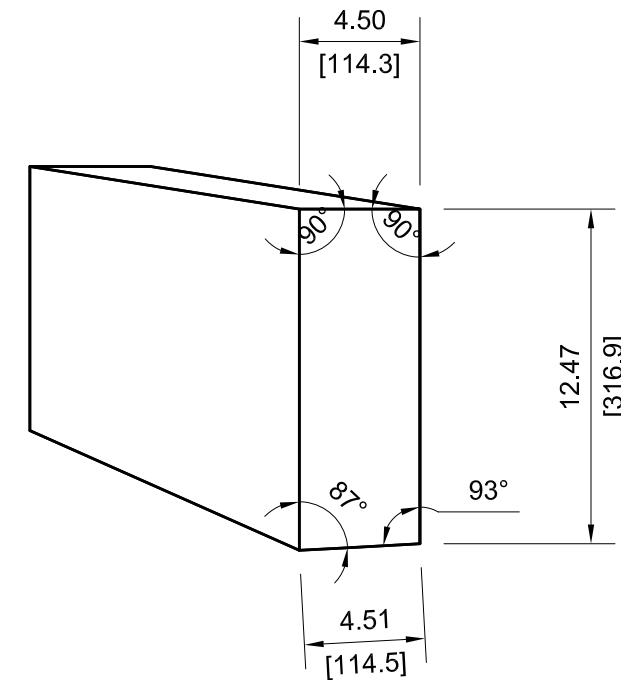
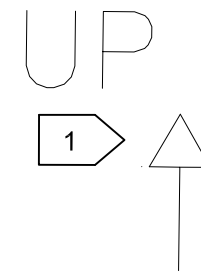

VIEW C8-116

NOTE: ALL VIEWS TAKEN AS TRUE VIEWS PARALLEL TO SURFACE OF PART

		DRAWING NUMBER			
		AES-D0002			
SIZE	SCALE	SHEET	OF	REVISION	
A3	NONE	116	167	F	

-297

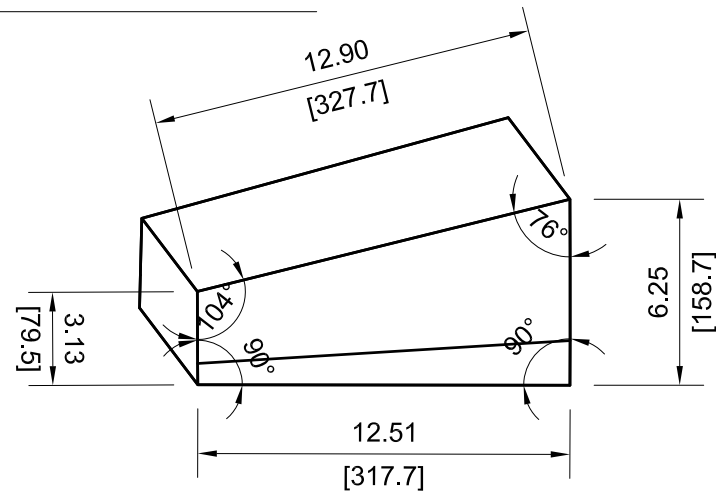

VIEW C4-117

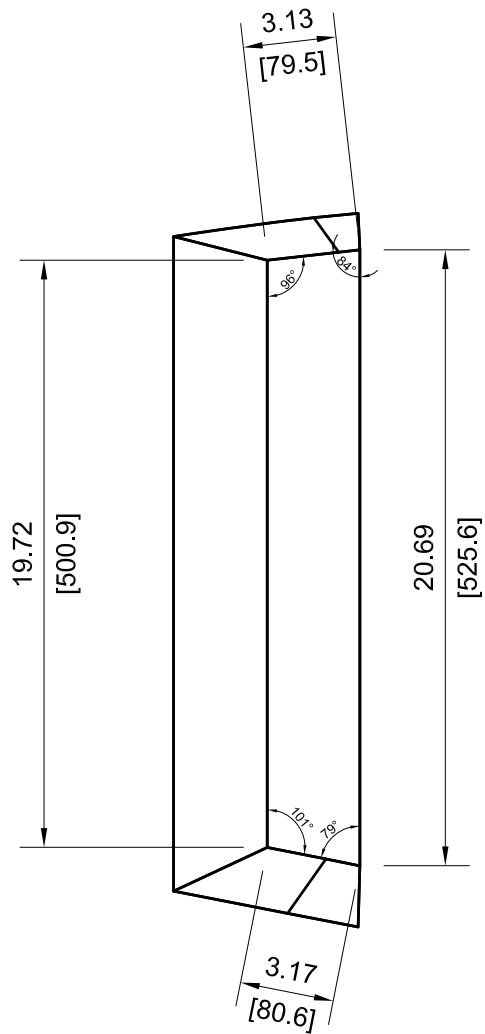

VIEW A7-117

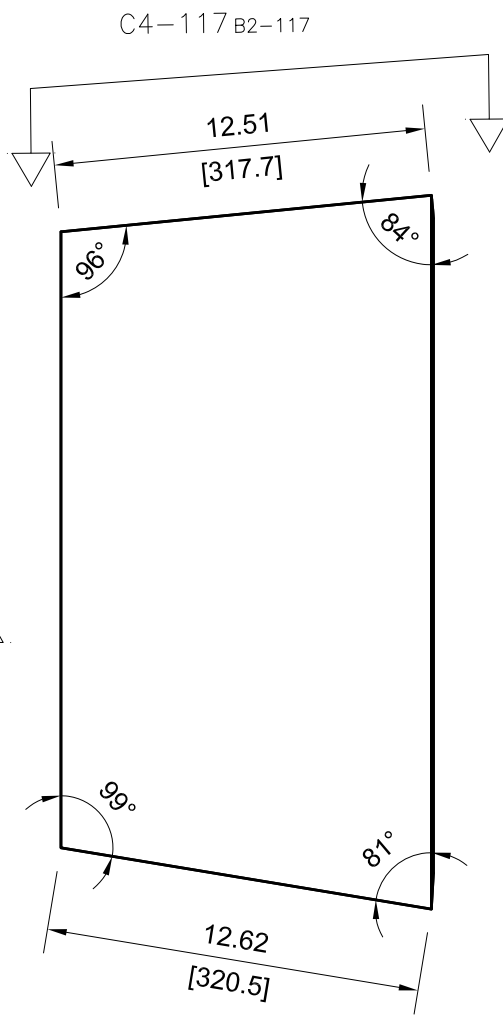

VIEW C7-117

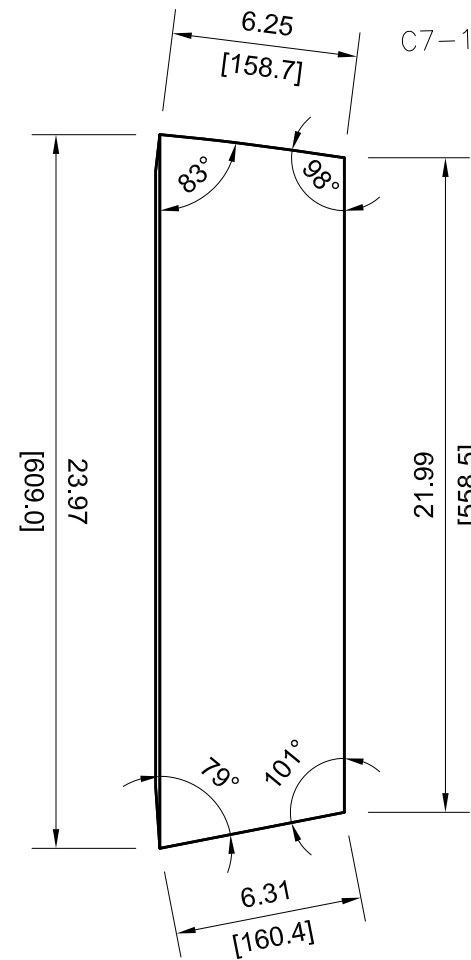

VIEW C8-117

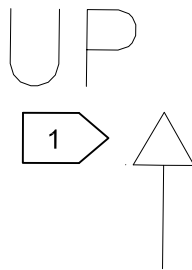
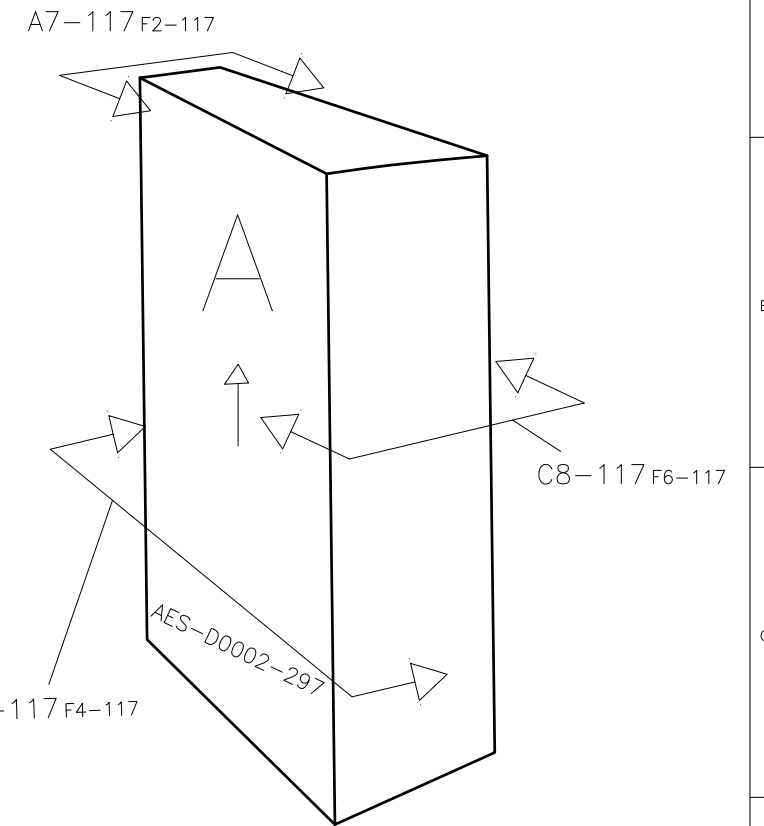

NOTE: ALL VIEWS TAKEN AS TRUE VIEWS PARALLEL TO SURFACE OF PART

		DRAWING NUMBER			
		AES-D0002			
SIZE	SCALE	SHEET	OF	REVISION	
A3	NONE	117	167	F	

-299

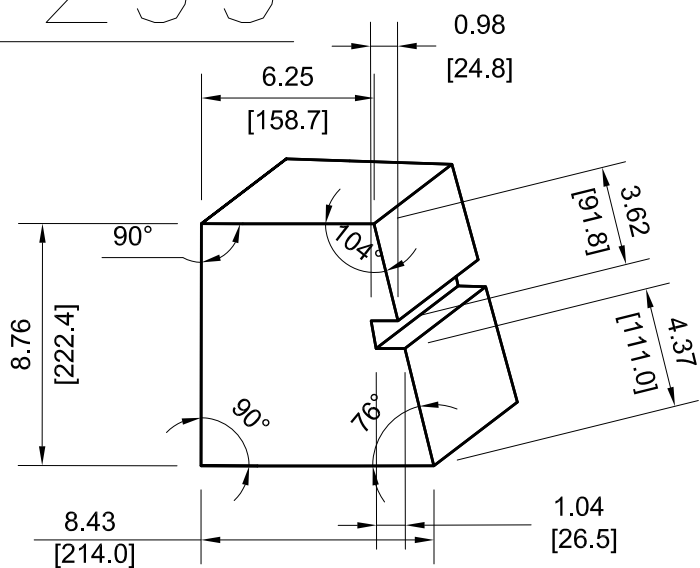

VIEW C4-118

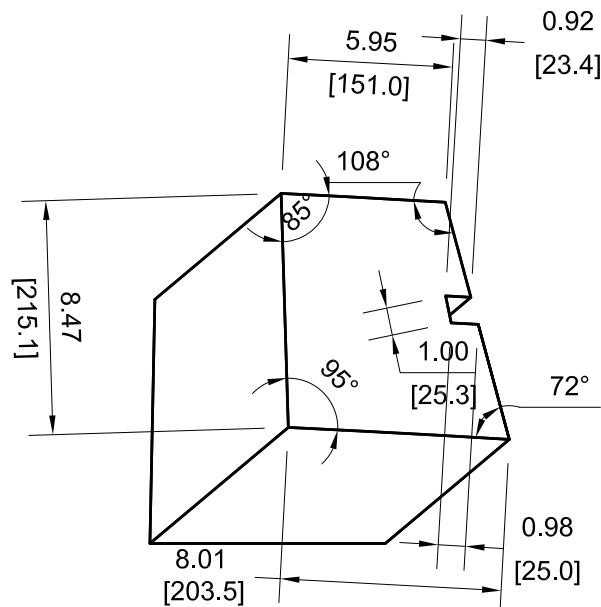

VIEW F4-118

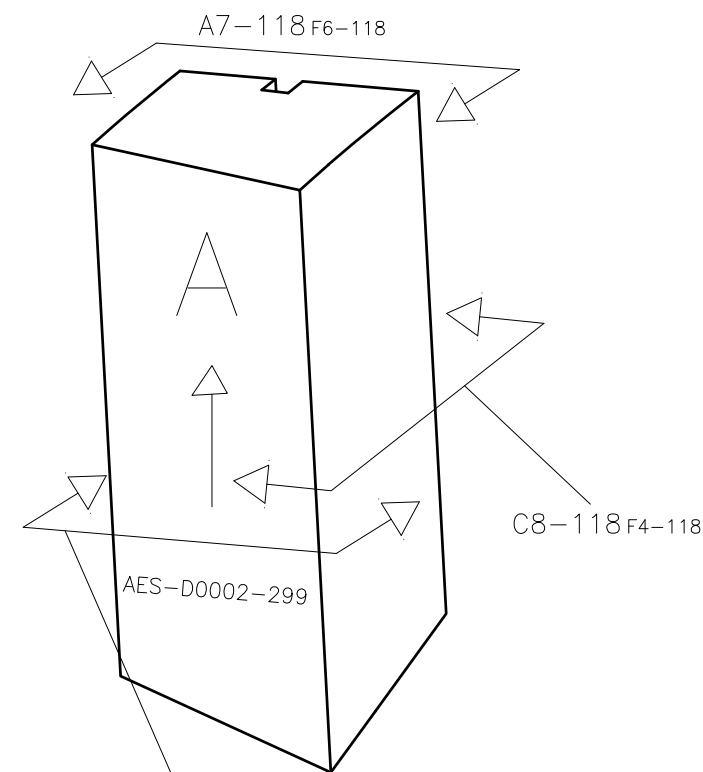

D7-118F2-118

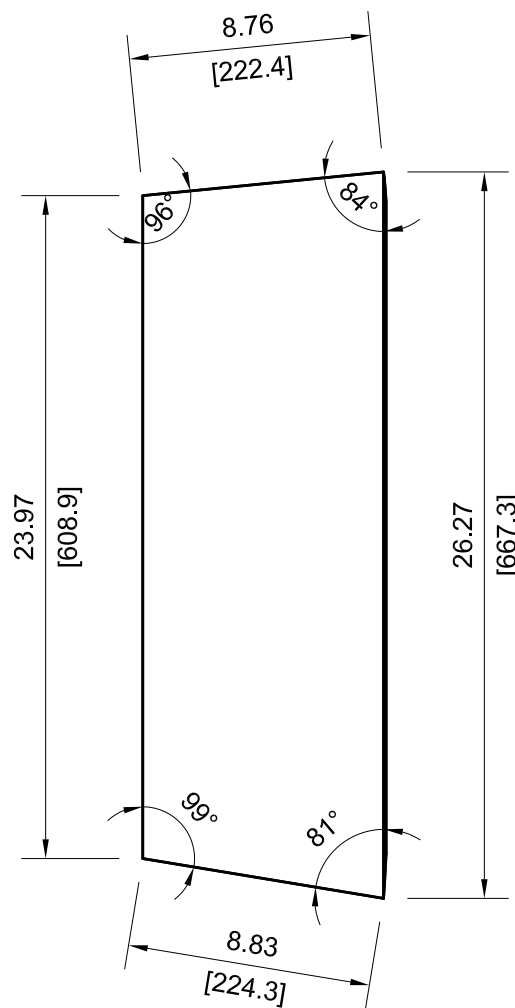

VIEW D7-118

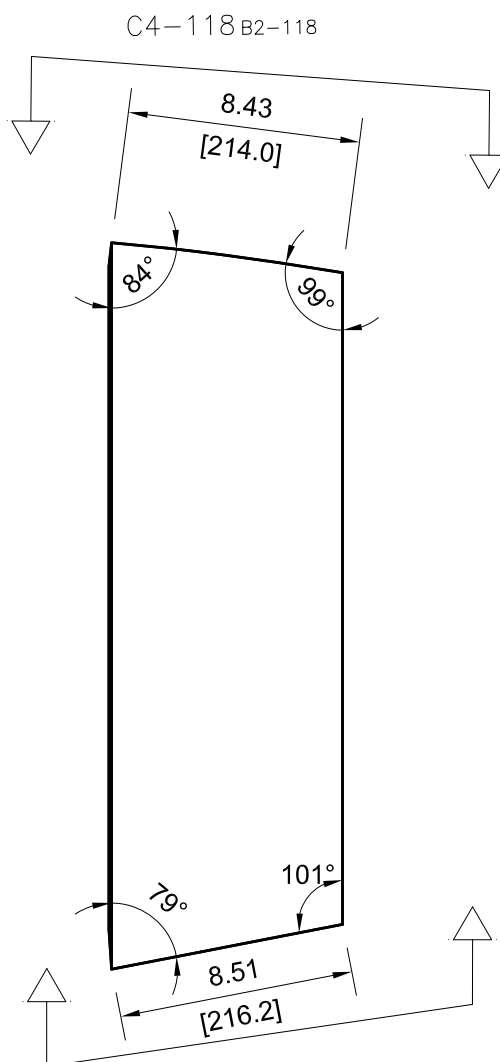

VIEW C8-118

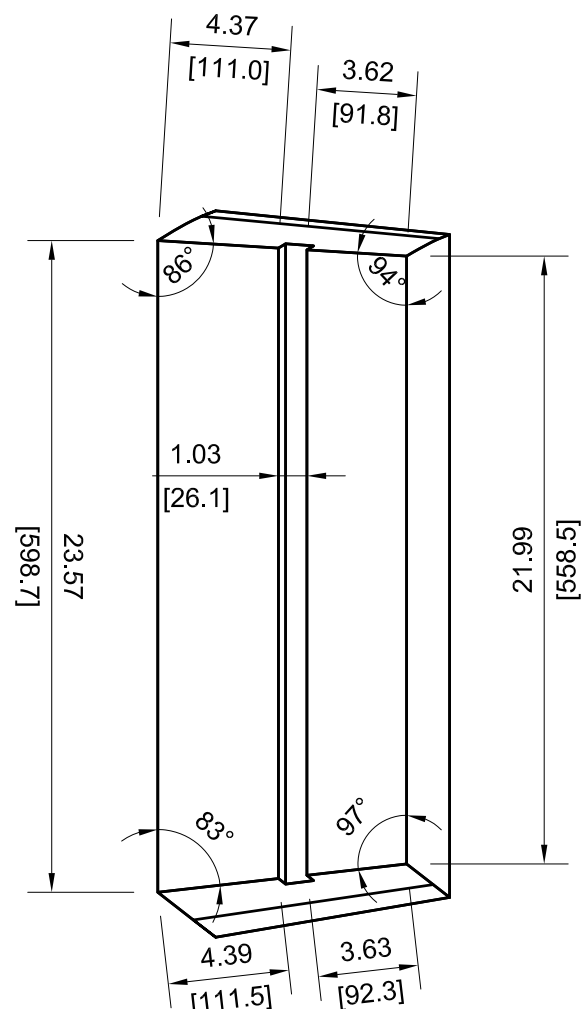

VIEW A7-118

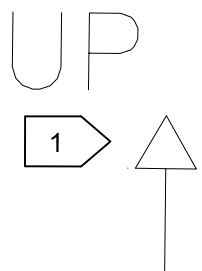

NOTE: ALL VIEWS TAKEN AS TRUE VIEWS PARALLEL TO SURFACE OF PART

		DRAWING NUMBER			
		AES-D0002			
SIZE	SCALE	SHEET	OF	REVISION	
A3	NONE	118	167	F	

-301

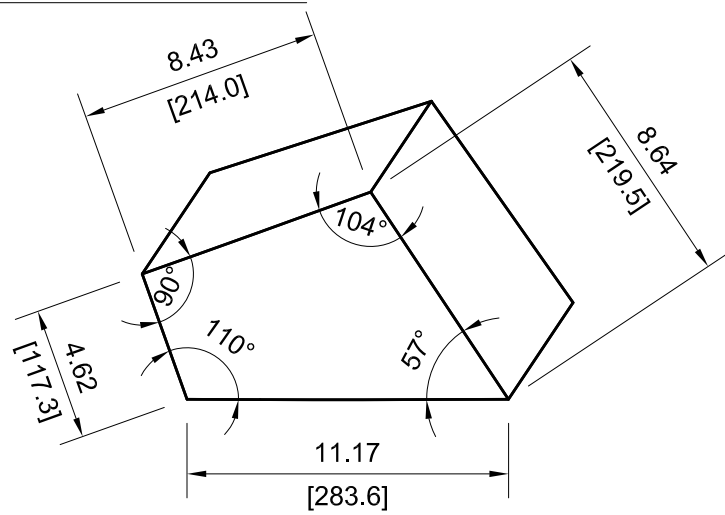

VIEW C4-119

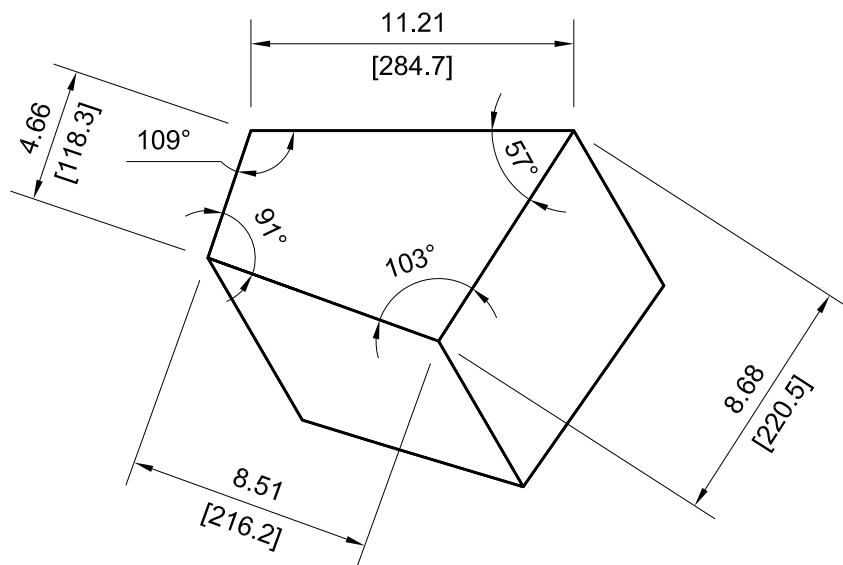

VIEW F4-119

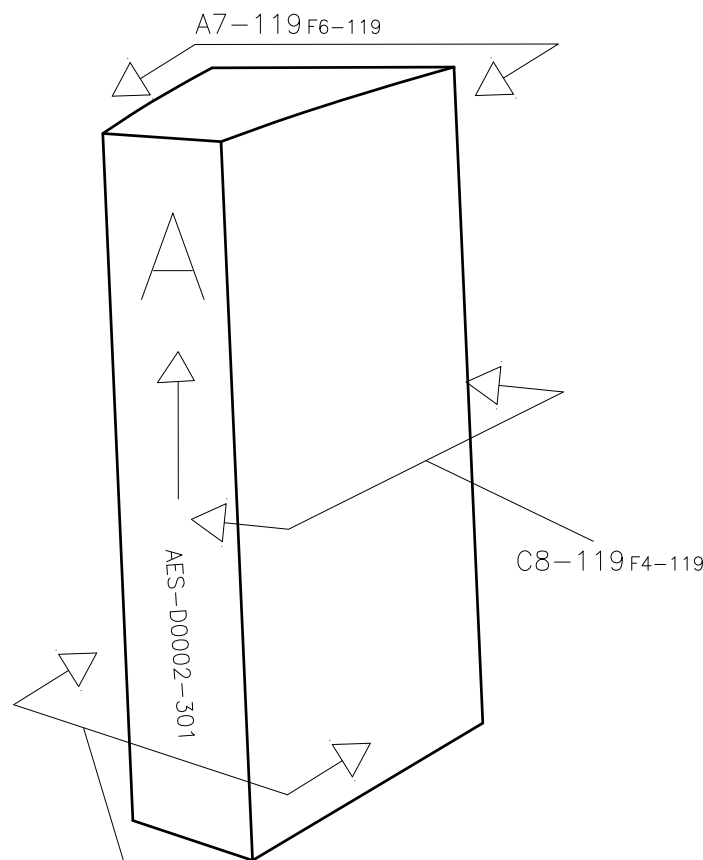

UP
1

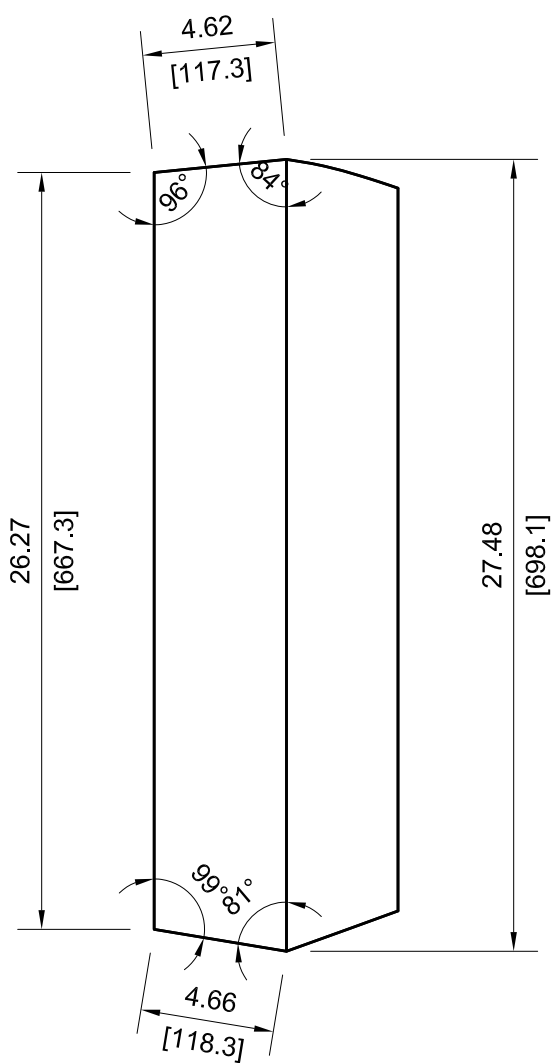

VIEW D7-119

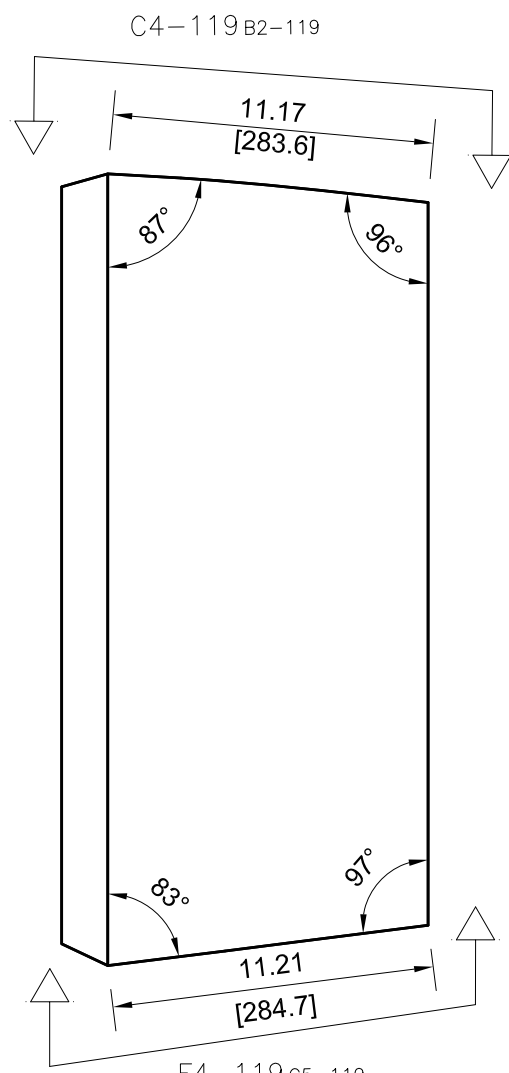

VIEW C8-119

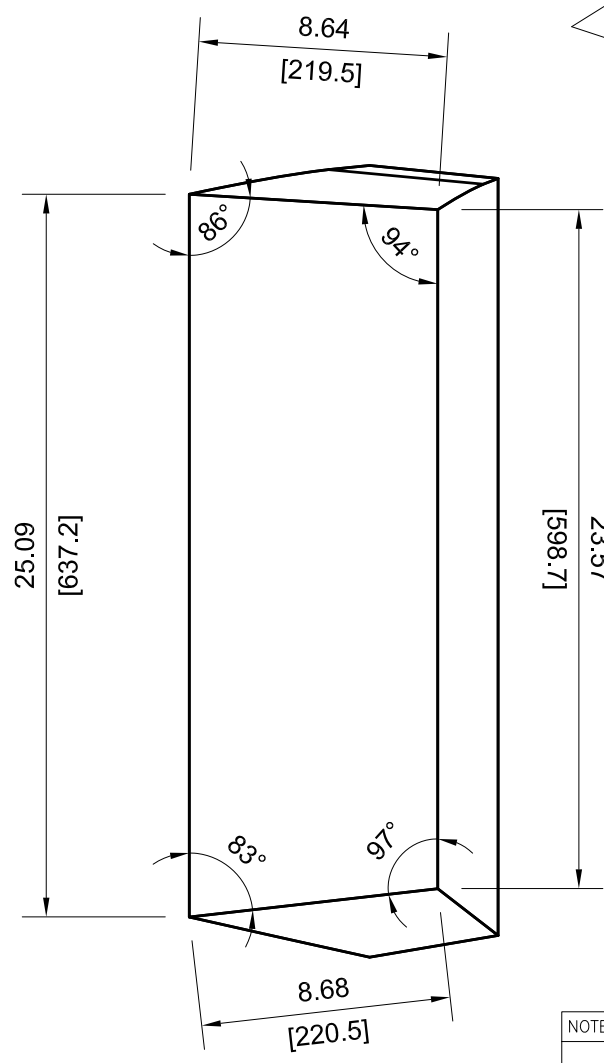

VIEW A7-119

NOTE: ALL VIEWS TAKEN AS TRUE VIEWS PARALLEL TO SURFACE OF PART

AerSale		DRAWING NUMBER			
		AES-D0002			
SIZE	SCALE	SHEET	OF	REVISION	
A3	NONE	119	167	F	

-303

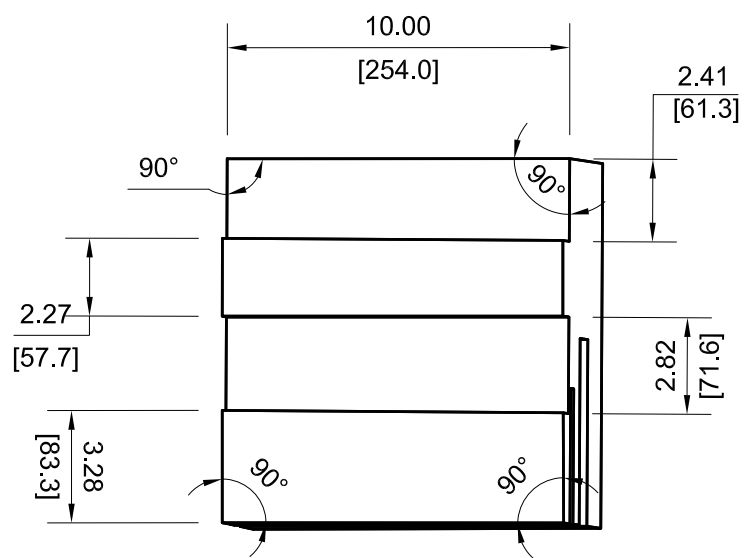

VIEW C4-120

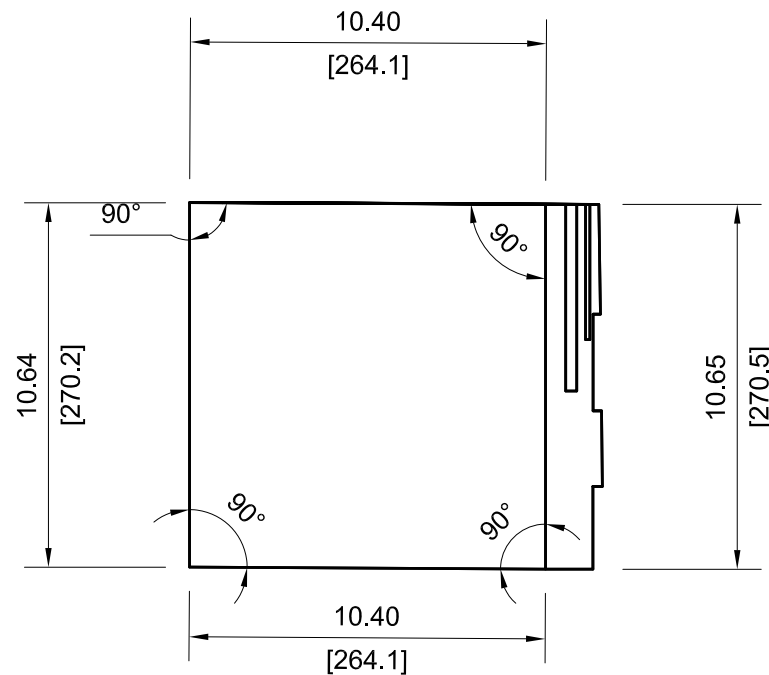

VIEW F4-120

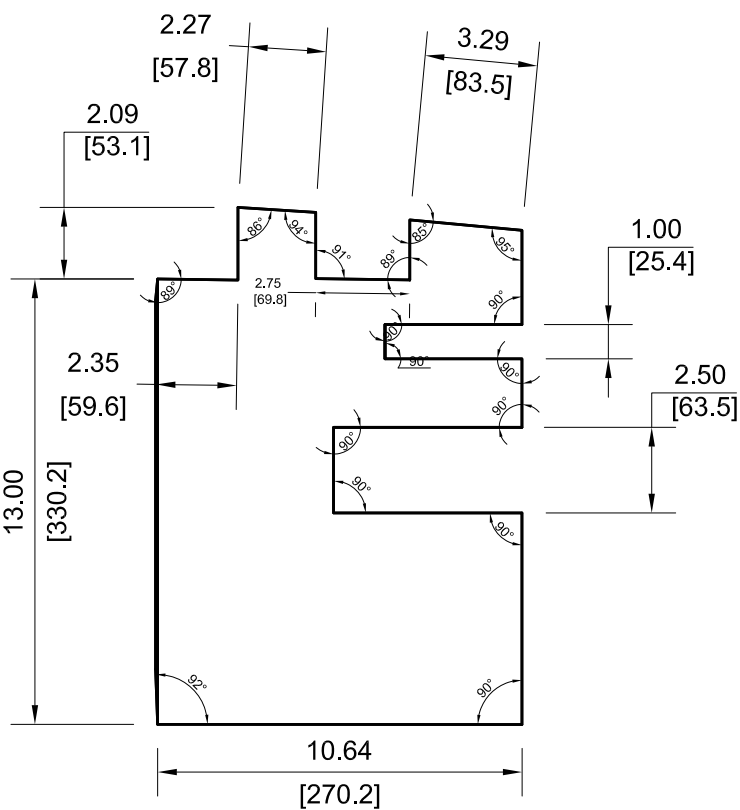
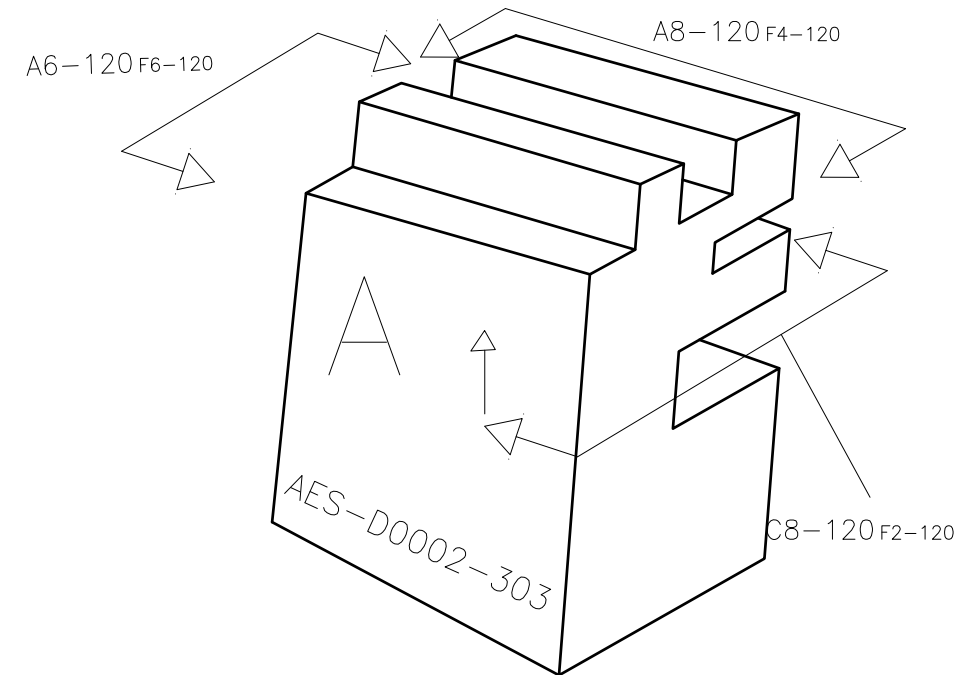

VIEW C8-120

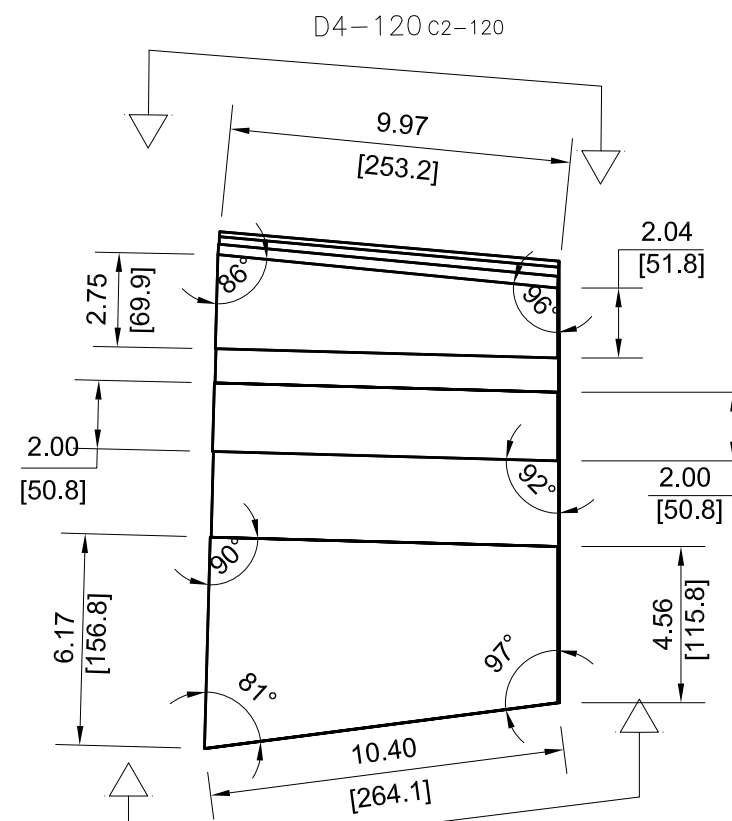

VIEW A8-120

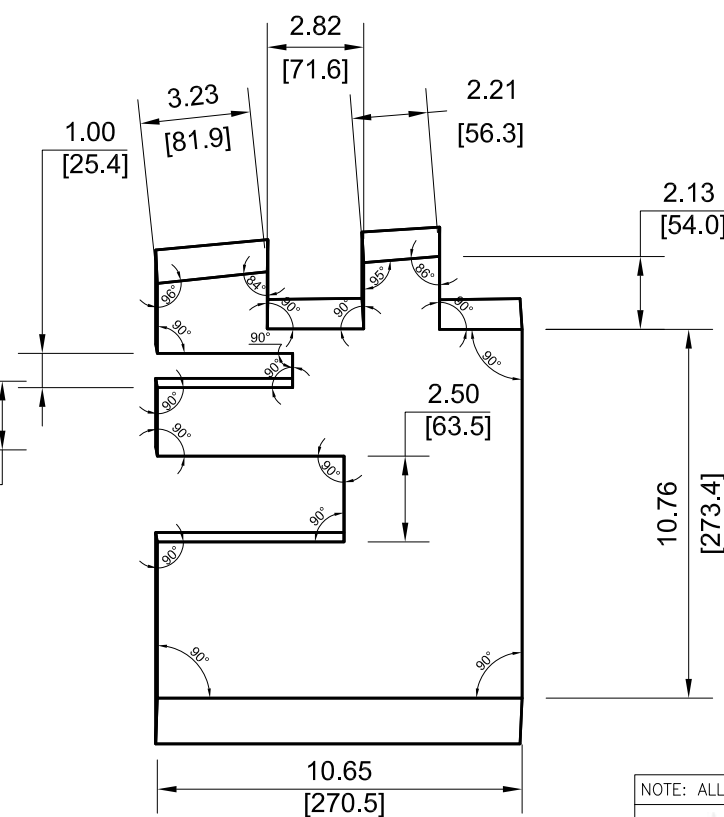

VIEW A7-120

NOTE: ALL VIEWS TAKEN AS TRUE VIEWS PARALLEL TO SURFACE OF PART

		DRAWING NUMBER			
		AES-D0002			
SIZE	SCALE	SHEET	OF	REVISION	
A3	NONE	120	167	F	

-307

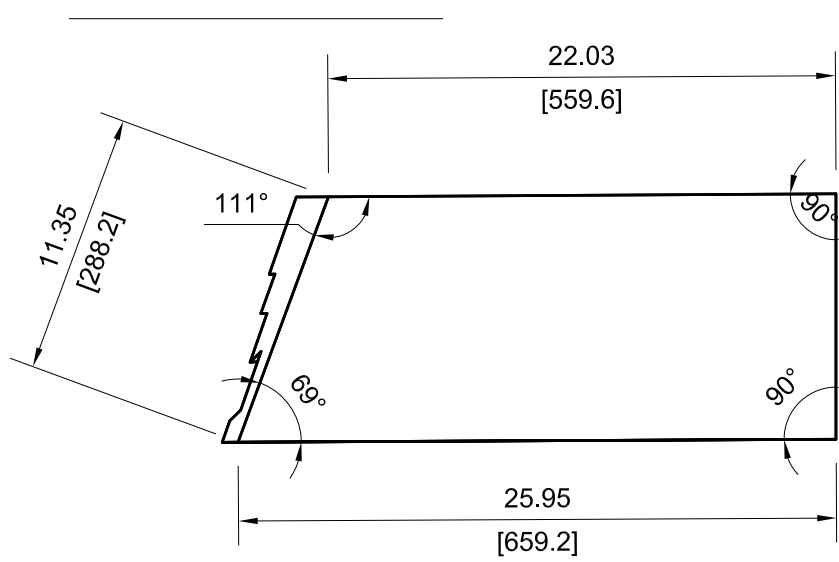

VIEW D4-122

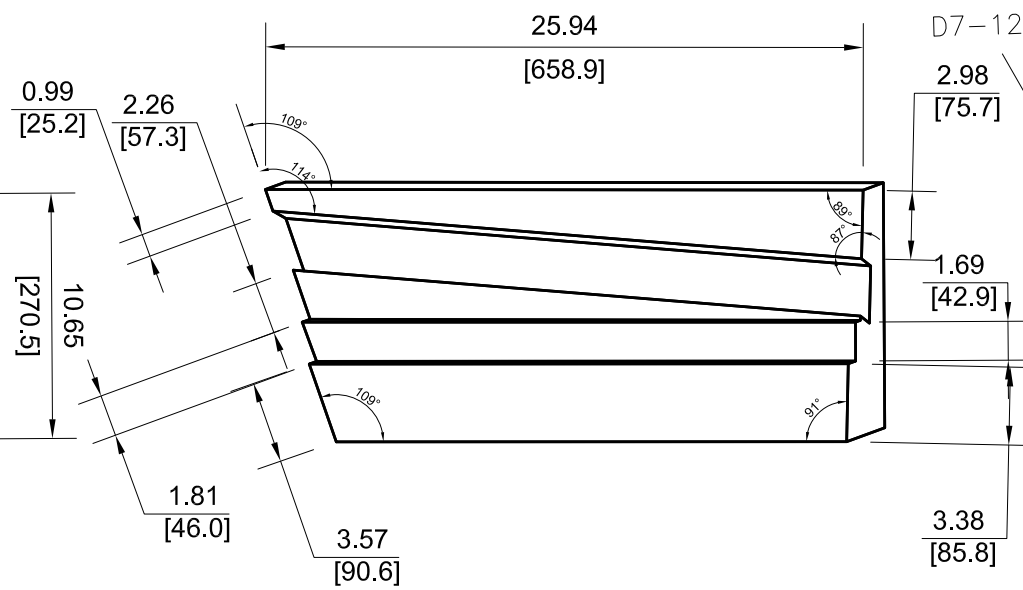

VIEW F4-122

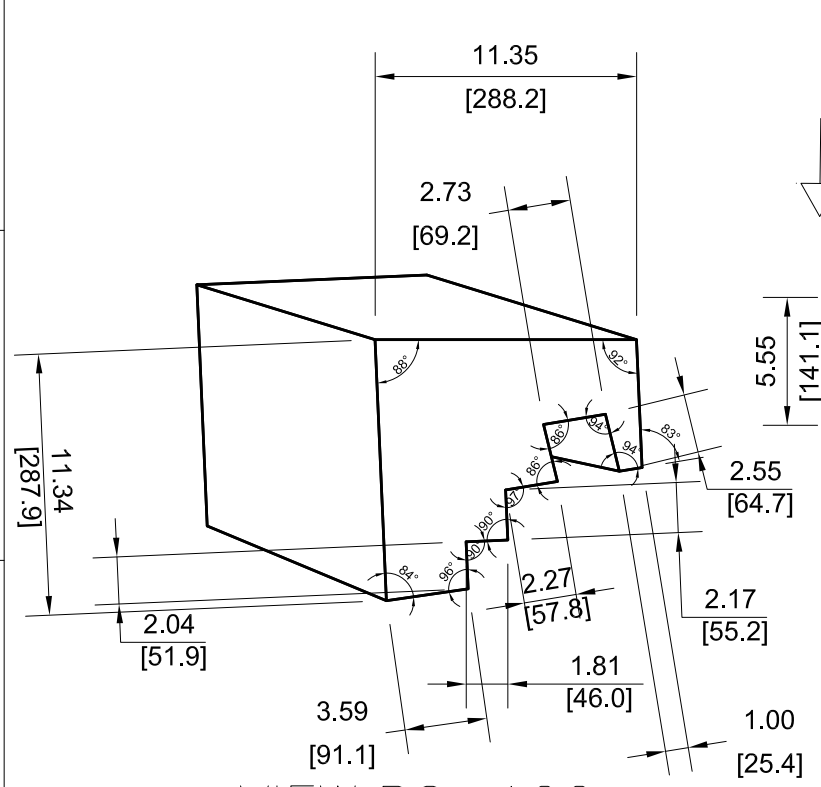
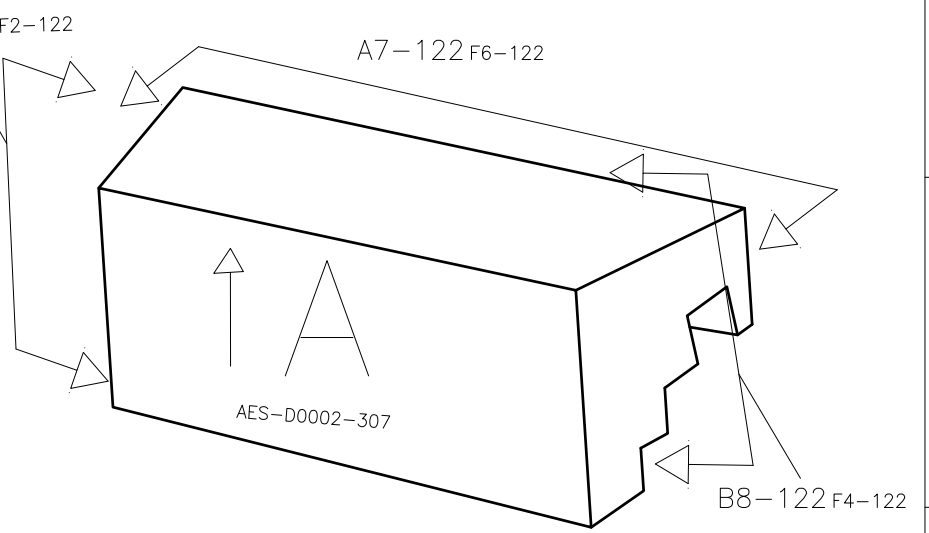

VIEW B8-122

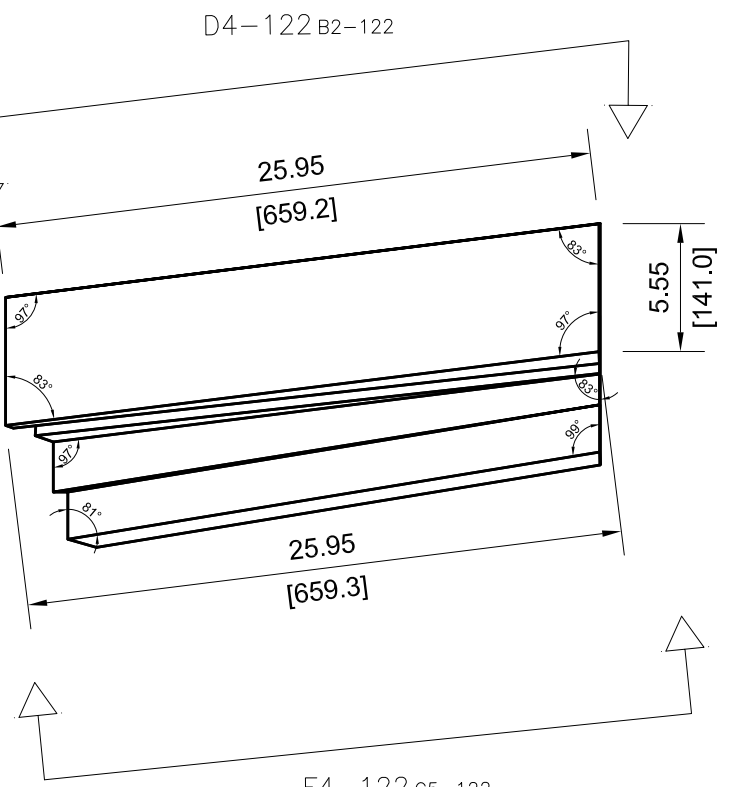

VIEW A7-122

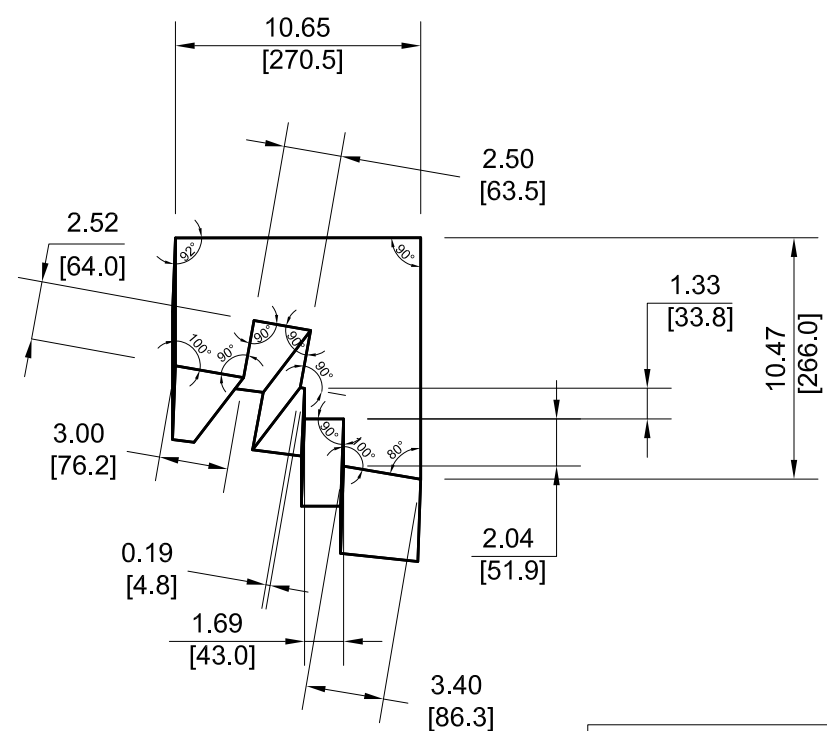

VIEW A7-122

NOTE: ALL VIEWS TAKEN AS TRUE VIEWS PARALLEL TO SURFACE OF PART

DRAWING NUMBER		AES-D0002			
SIZE	SCALE	SHEET	OF	REVISION	
A3	NONE	122	167	F	

-309

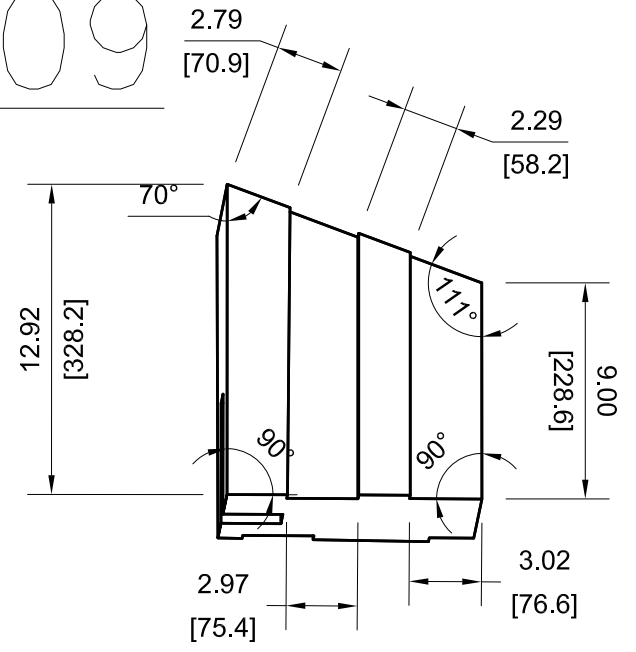

VIEW C4-123

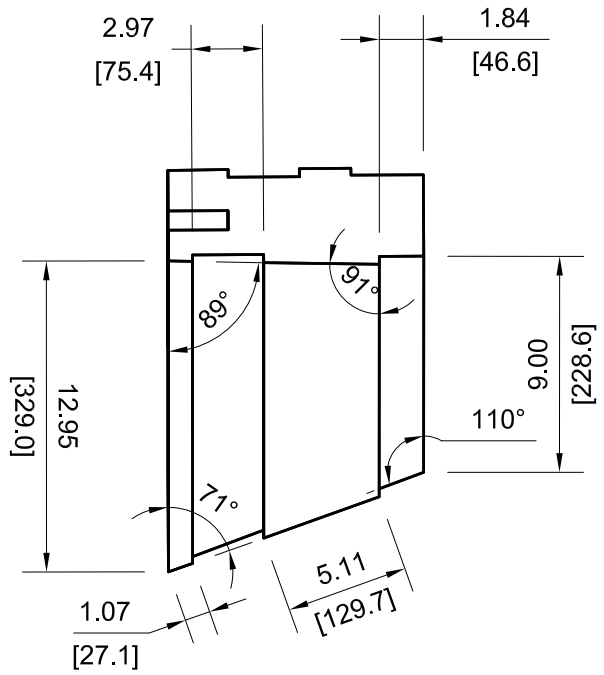

VIEW F4-123

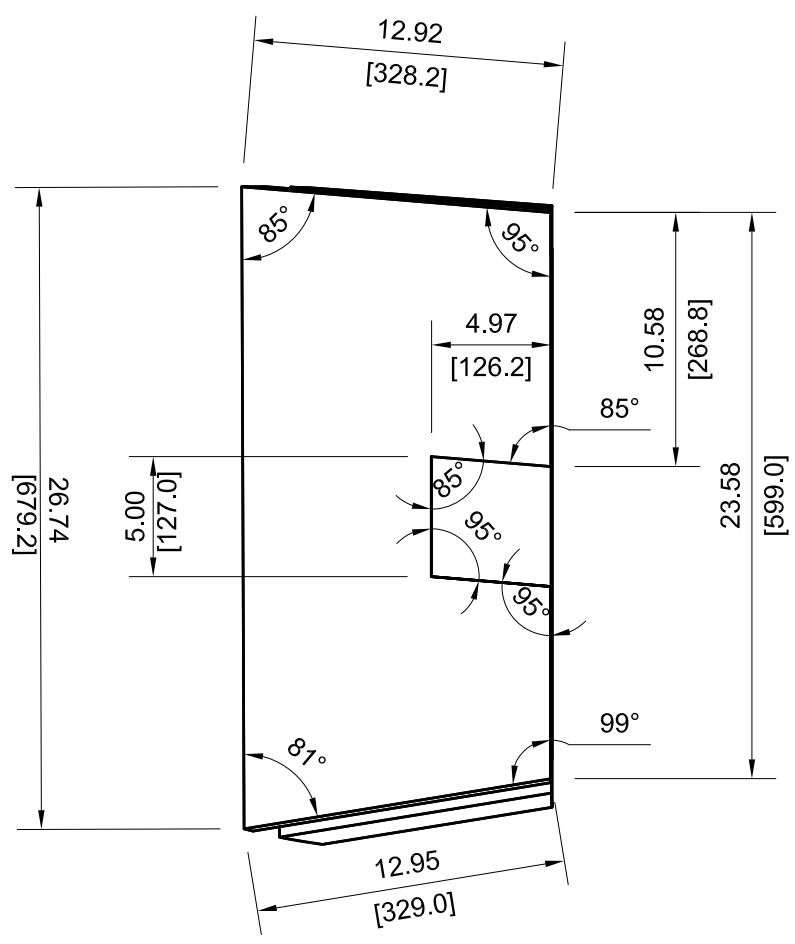
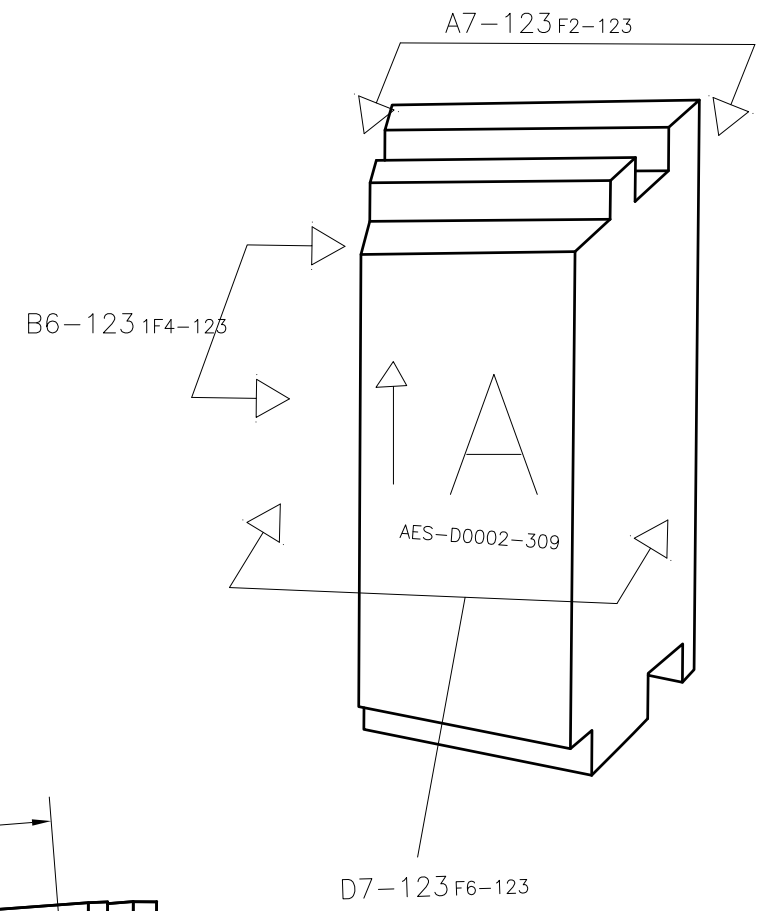

VIEW A7-123

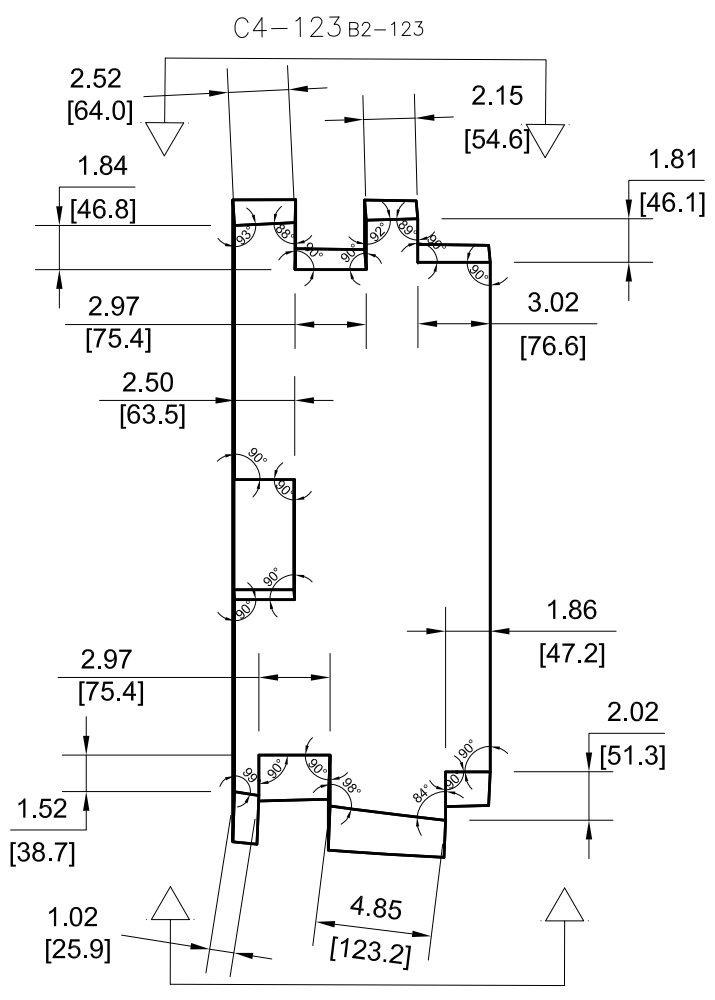

VIEW B6-123

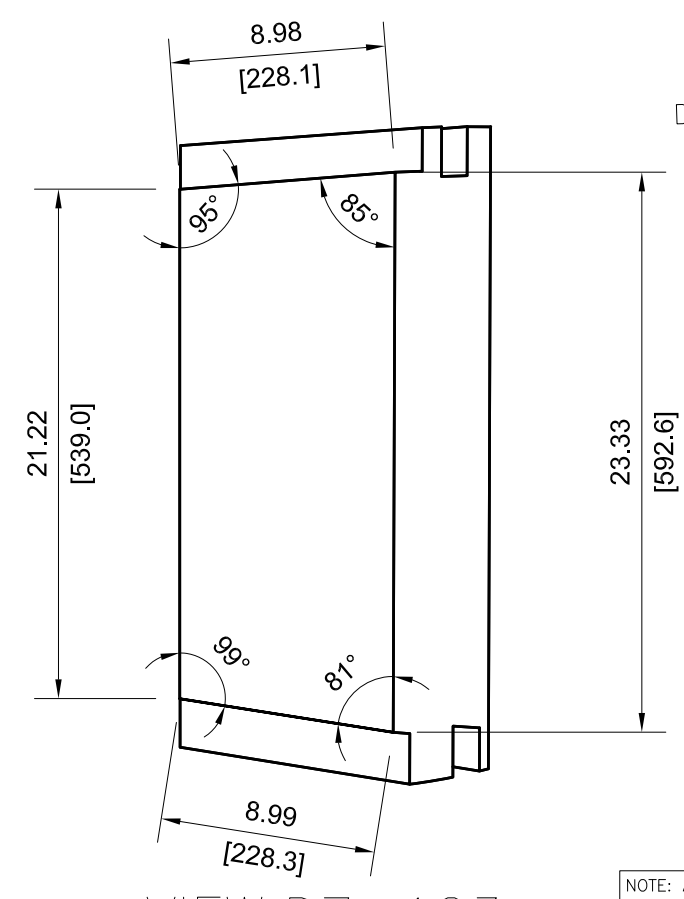

VIEW D7-123

NOTE: ALL VIEWS TAKEN AS TRUE VIEWS PARALLEL TO SURFACE OF PART

DRAWING NUMBER		AES-D0002		
SIZE	SCALE	SHEET	OF	REVISION
A3	NONE	123	167	F

-311

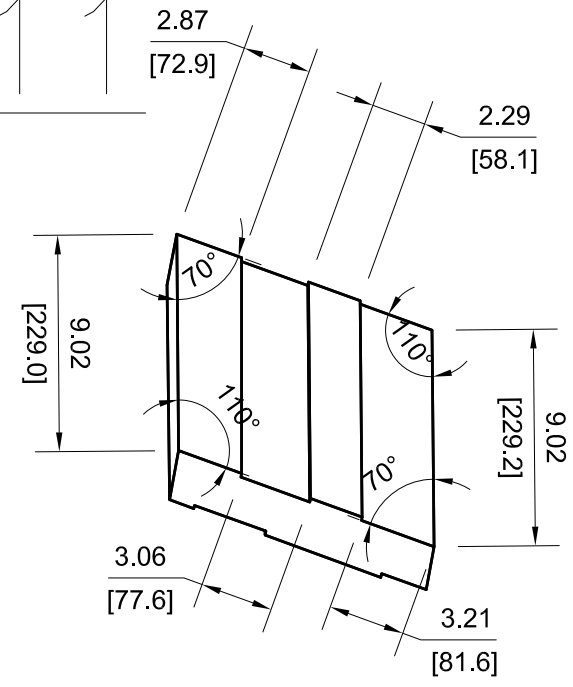

VIEW C4-124

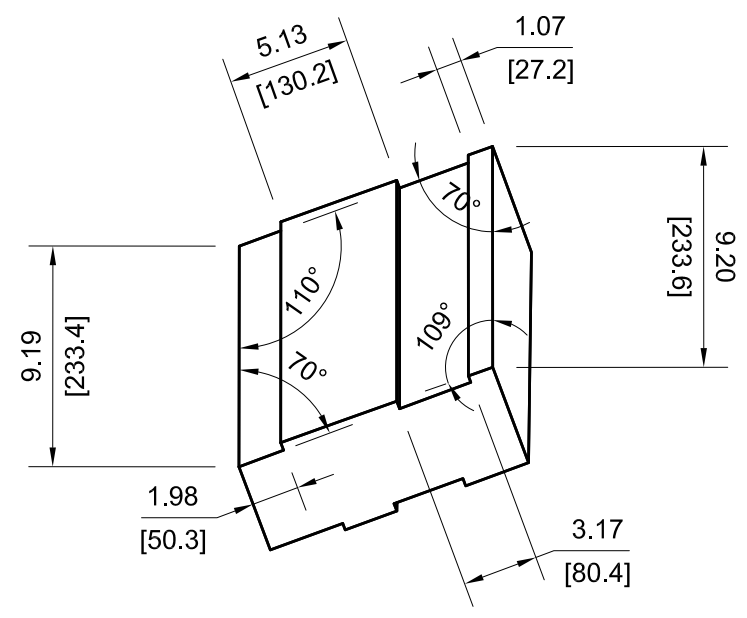

VIEW F4-124

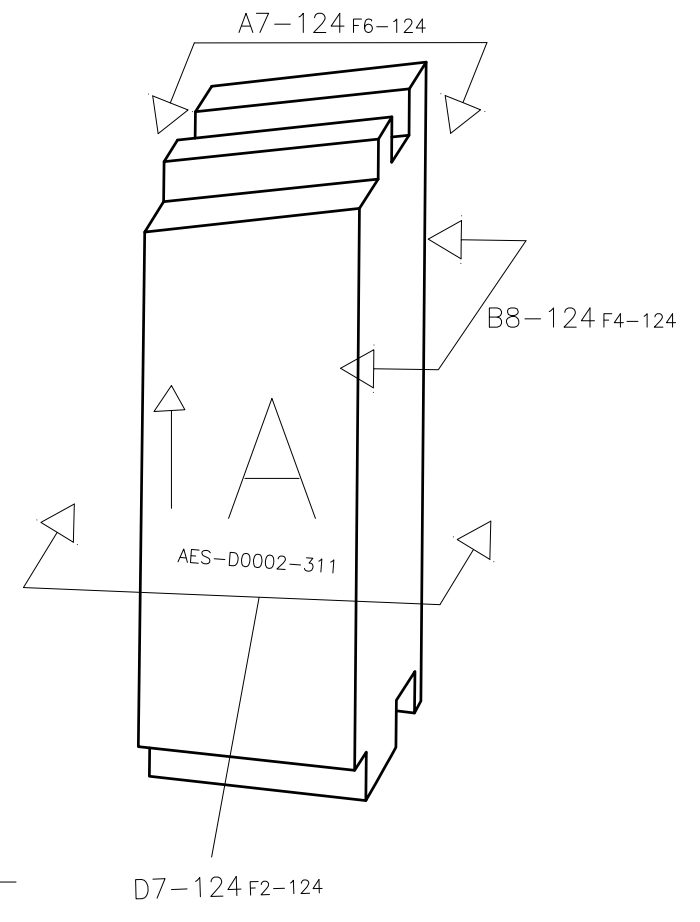

VIEW D7-124

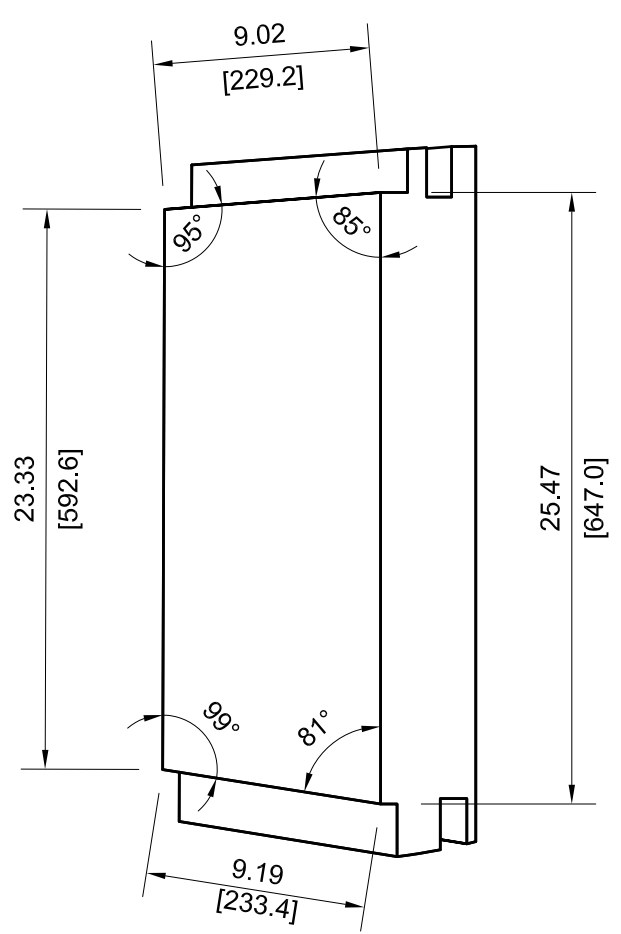

VIEW D7-124

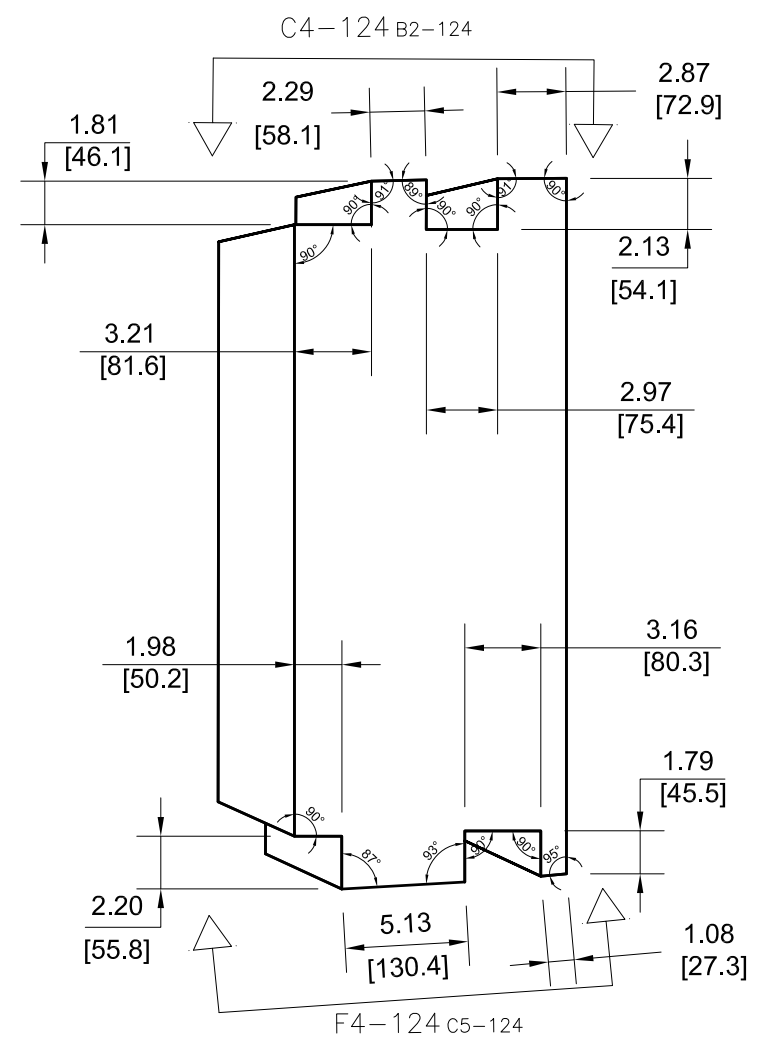

VIEW B8-124

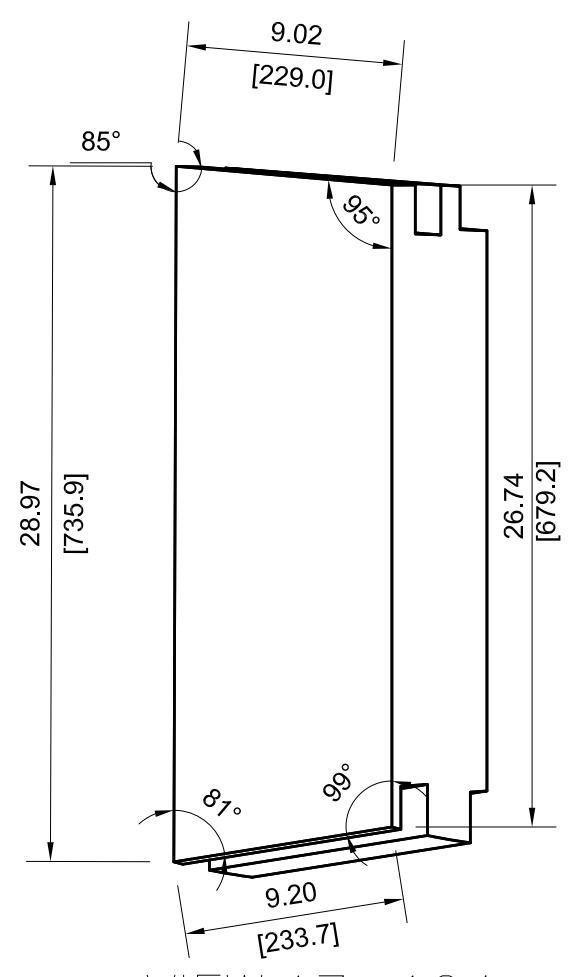

VIEW A7-124

NOTE: ALL VIEWS TAKEN AS TRUE VIEWS PARALLEL TO SURFACE OF PART

		DRAWING NUMBER			
		AES-D0002			
SIZE	SCALE	SHEET	OF	REVISION	
A3	NONE	124	167	F	

-313

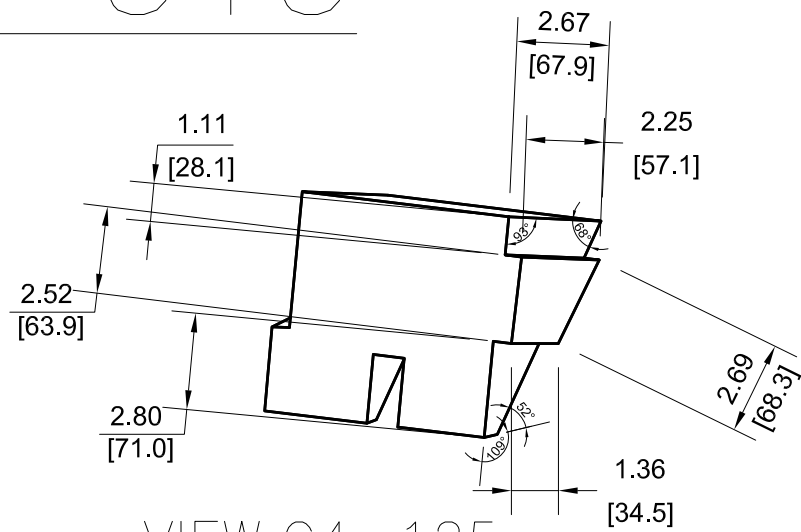

VIEW C4-125

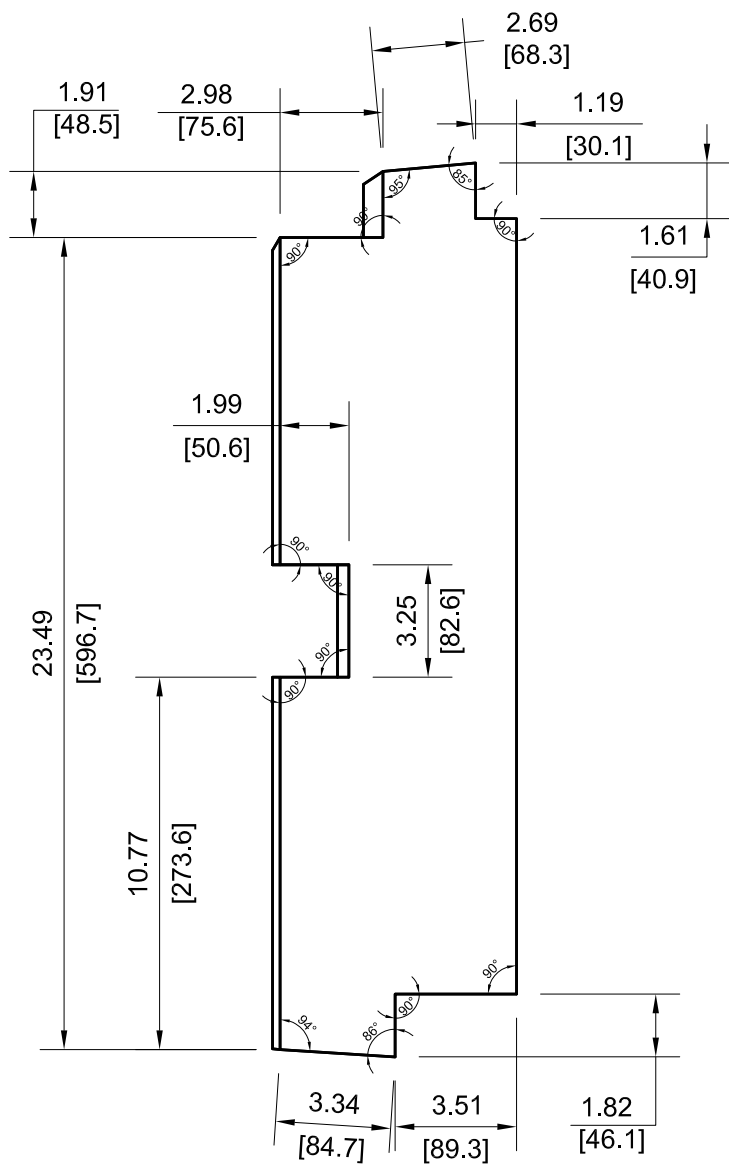

VIEW A7-125

C4-125 B2-125

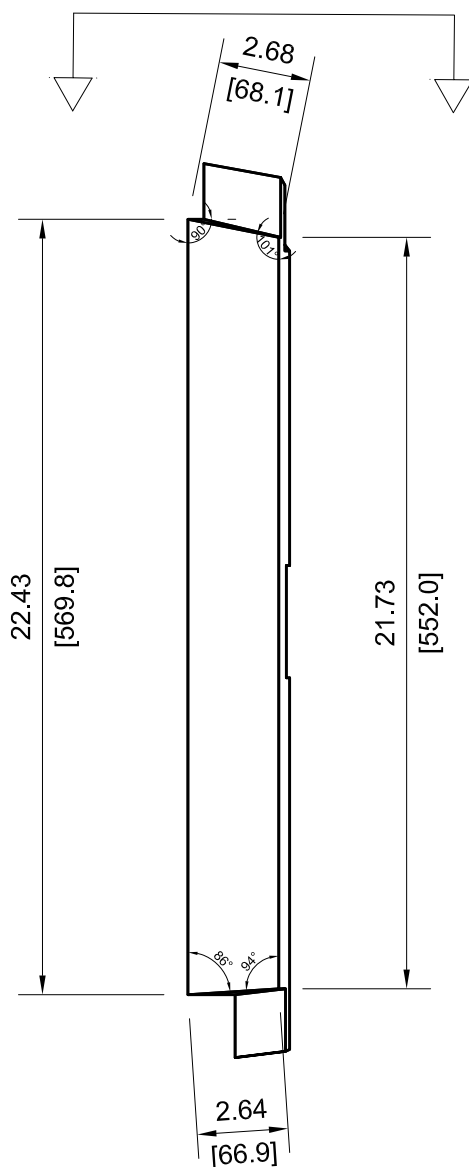

VIEW D7-125

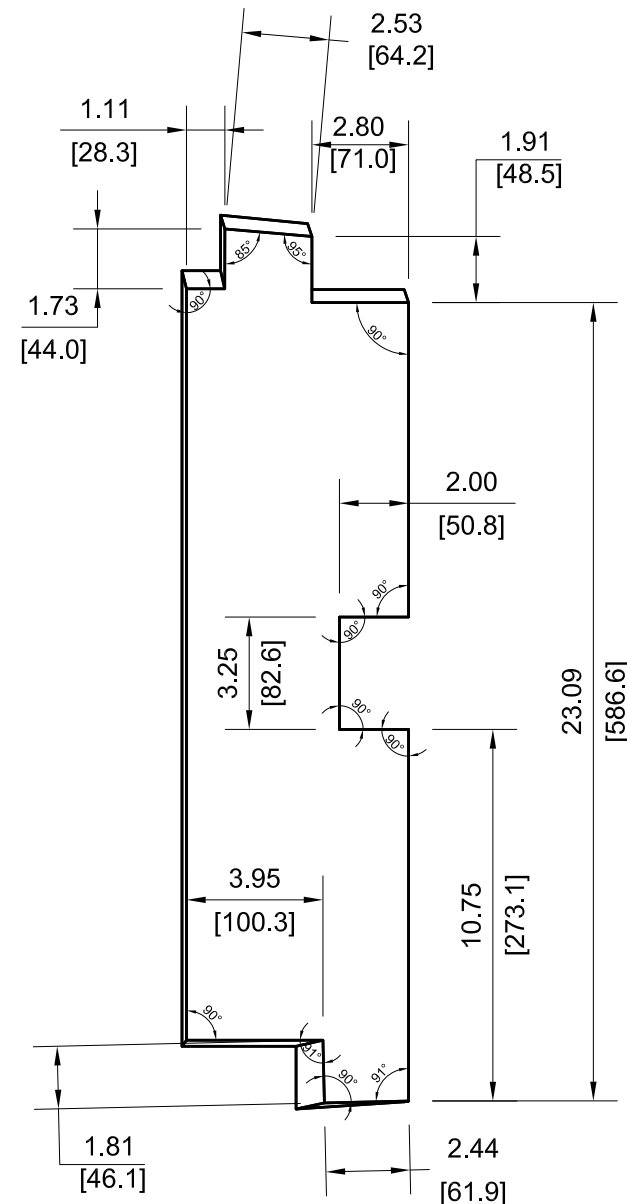

VIEW B8-125

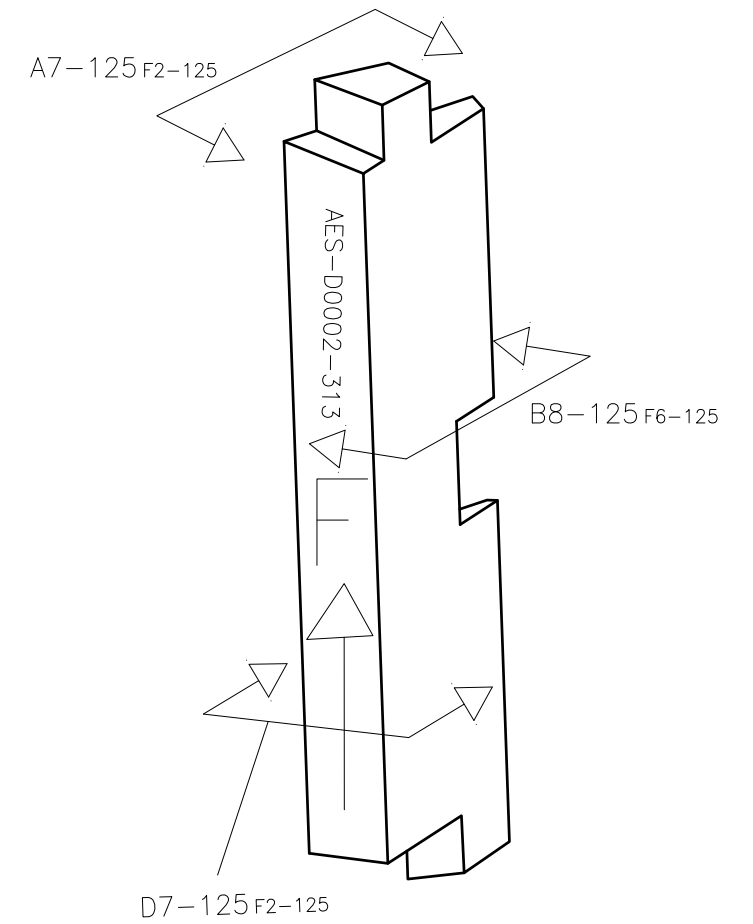

NOTE: ALL VIEWS TAKEN AS TRUE VIEWS PARALLEL TO SURFACE OF PART

		DRAWING NUMBER			
		AES-D0002			
SIZE	SCALE	SHEET	OF	REVISION	
A3	NONE	125	167	F	

-315

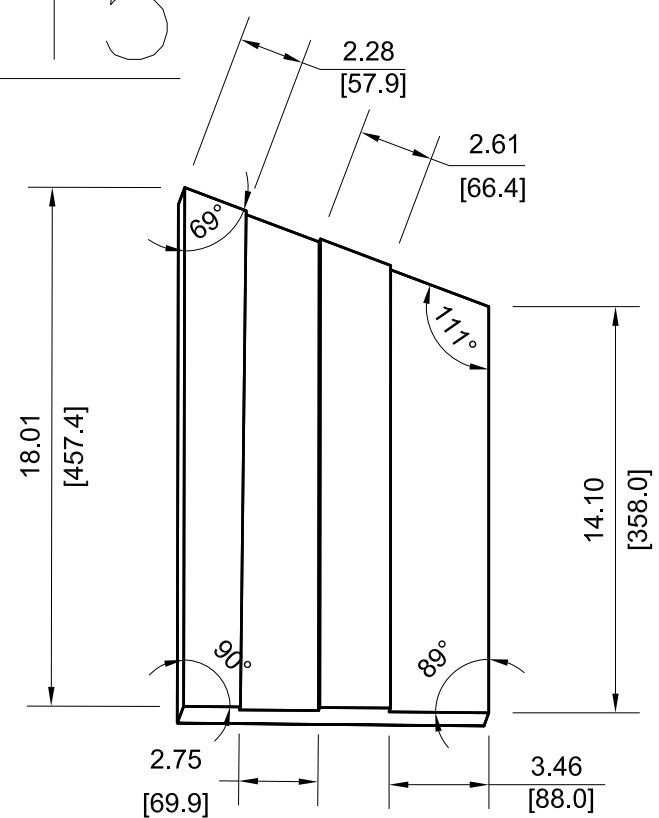

VIEW D4-126

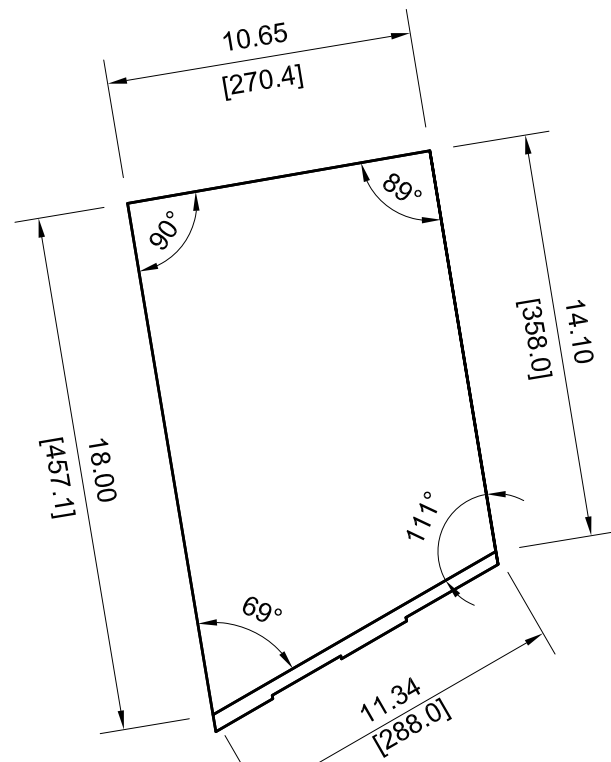

VIEW F4-126

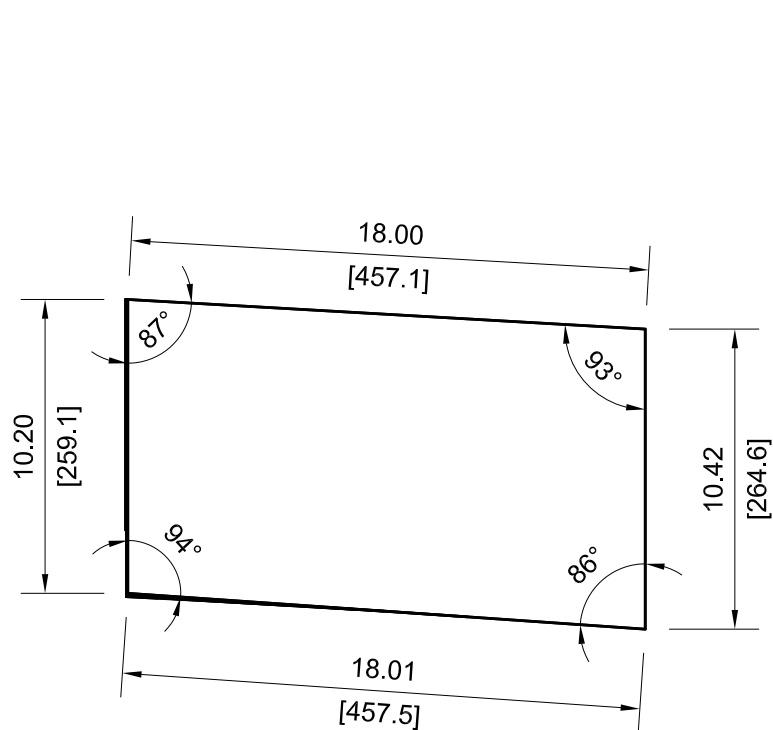
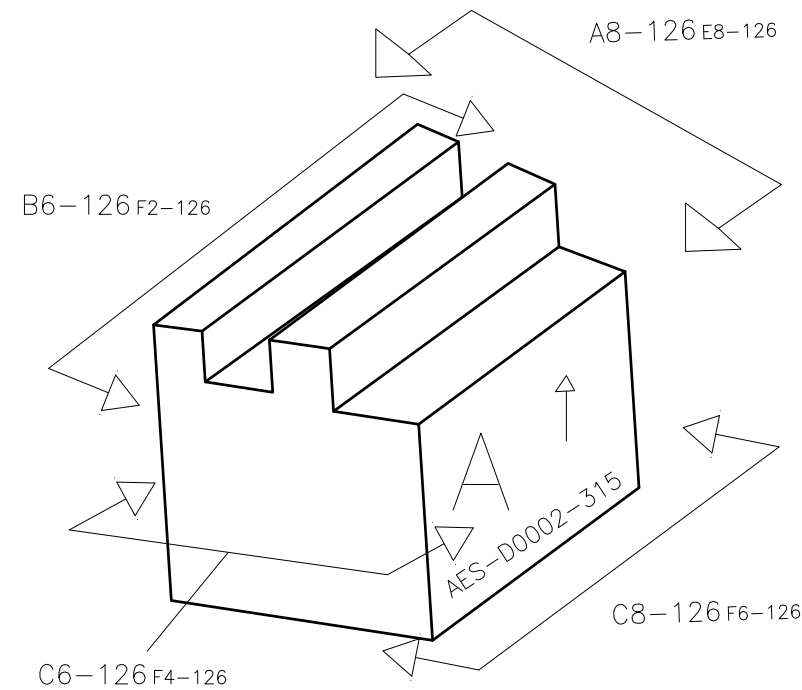

VIEW B6-126

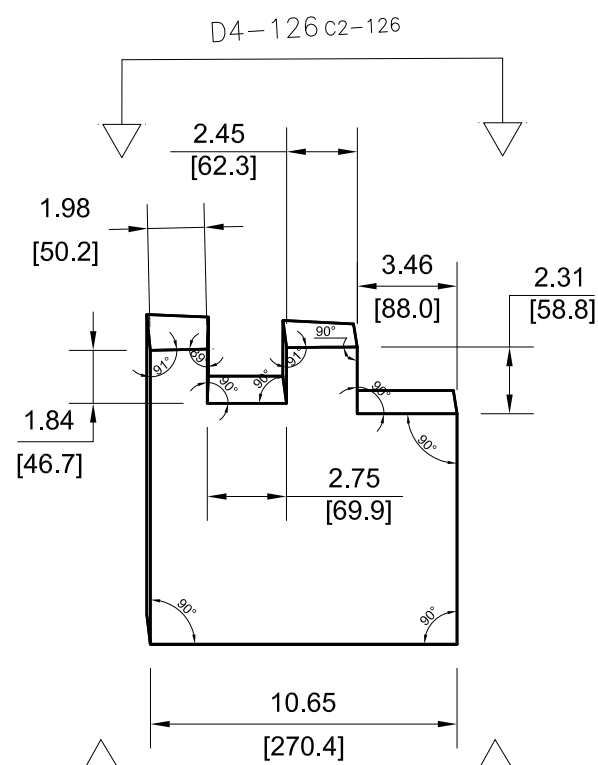

VIEW C6-126

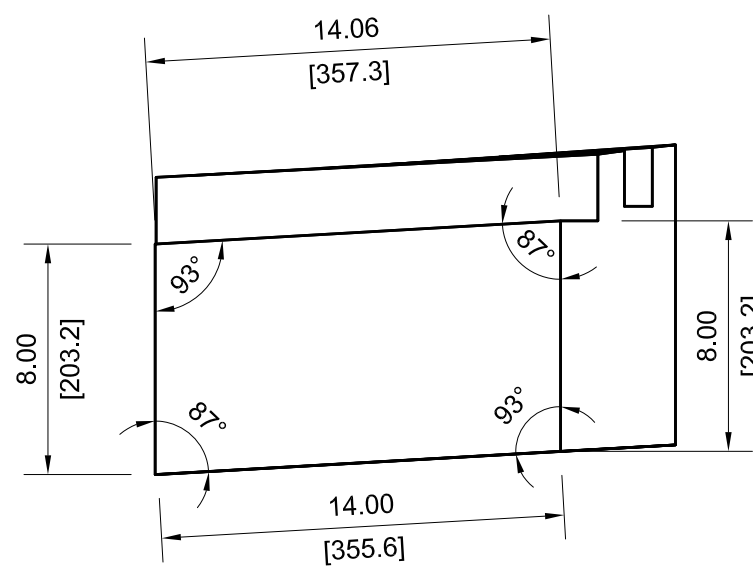

VIEW C8-126

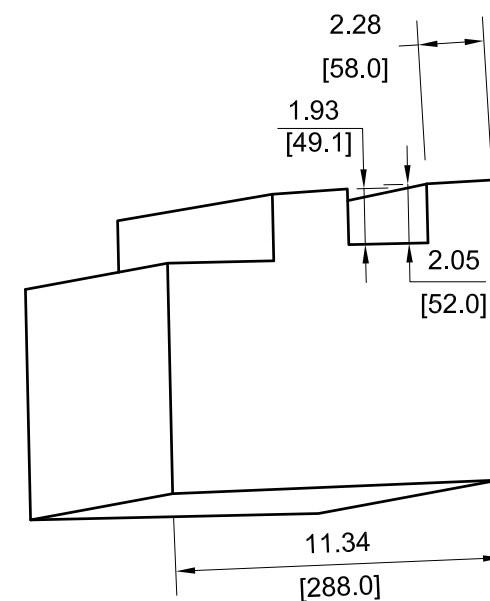

VIEW A8-126

NOTE: ALL VIEWS TAKEN AS TRUE VIEWS PARALLEL TO SURFACE OF PART

		DRAWING NUMBER			
		AES-D0002			
SIZE	SCALE	SHEET	OF	REVISION	
A3	NONE	126	167	F	

-317

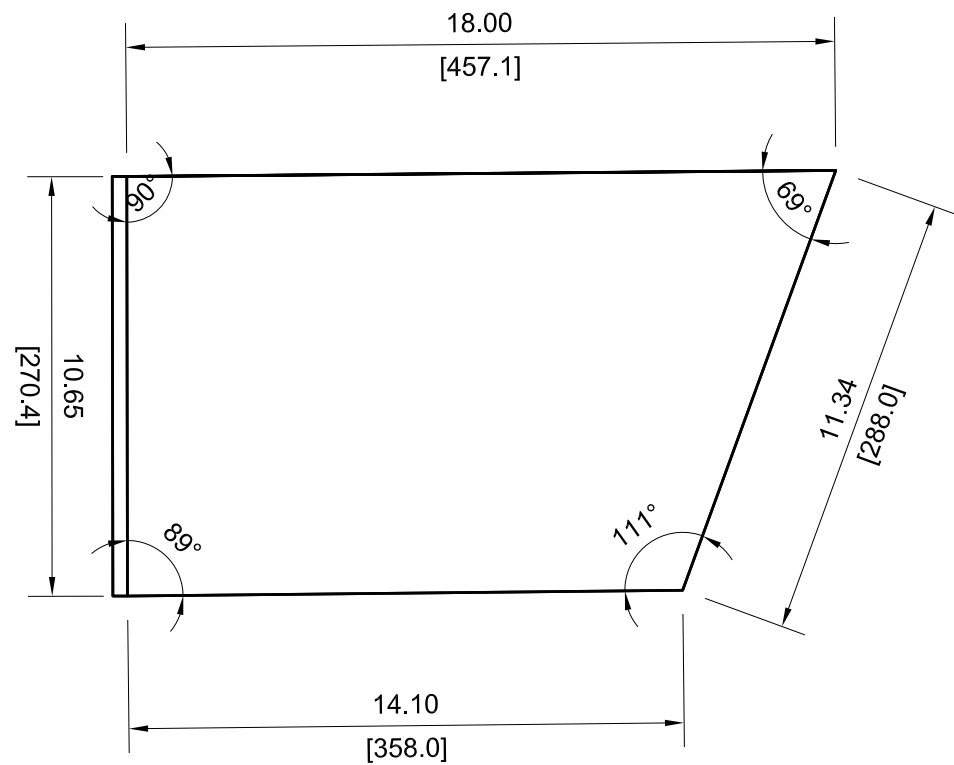

VIEW D4-127

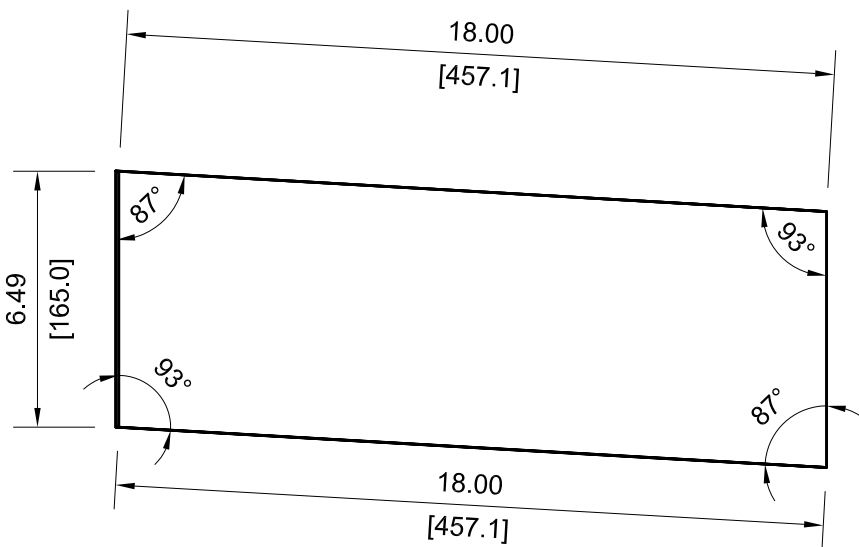
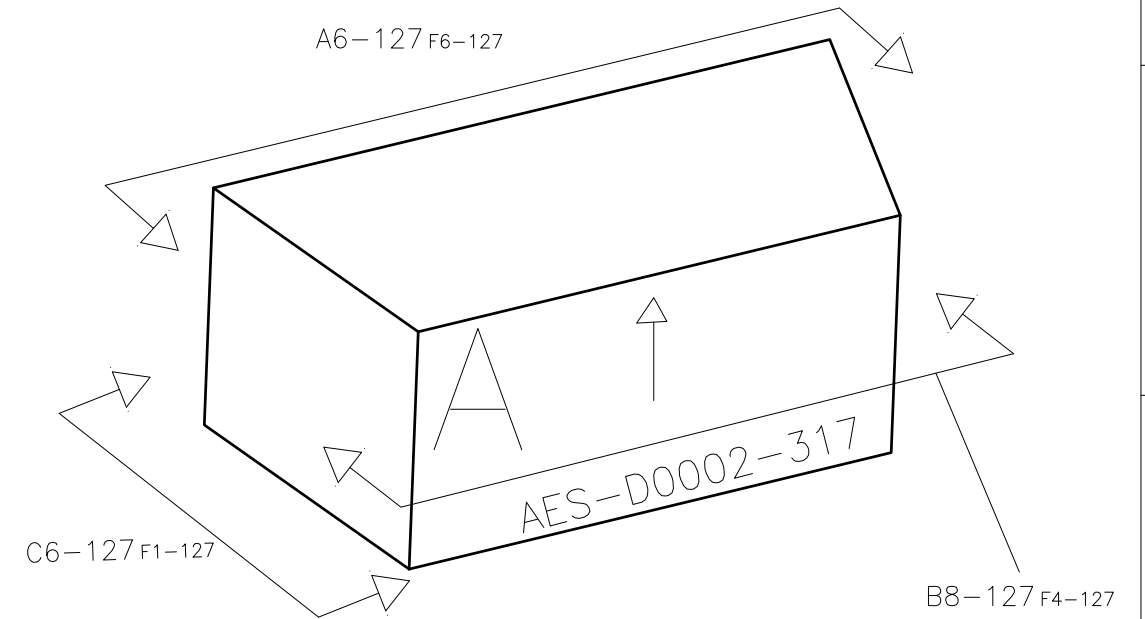

VIEW C6-127

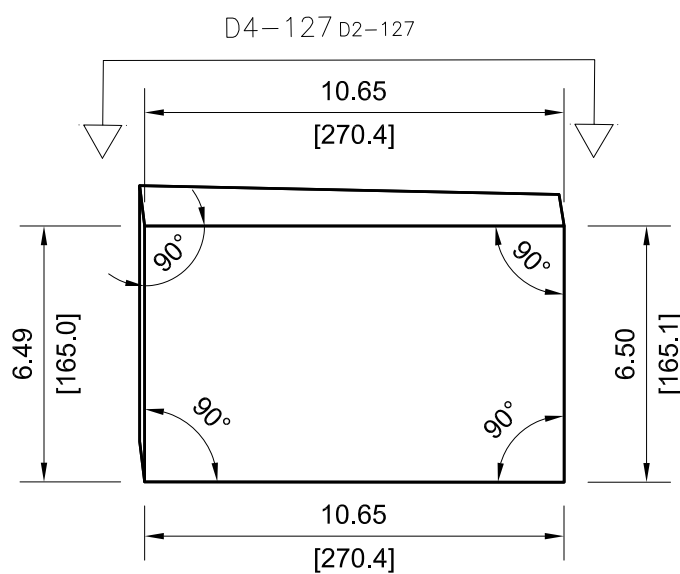

VIEW B8-127

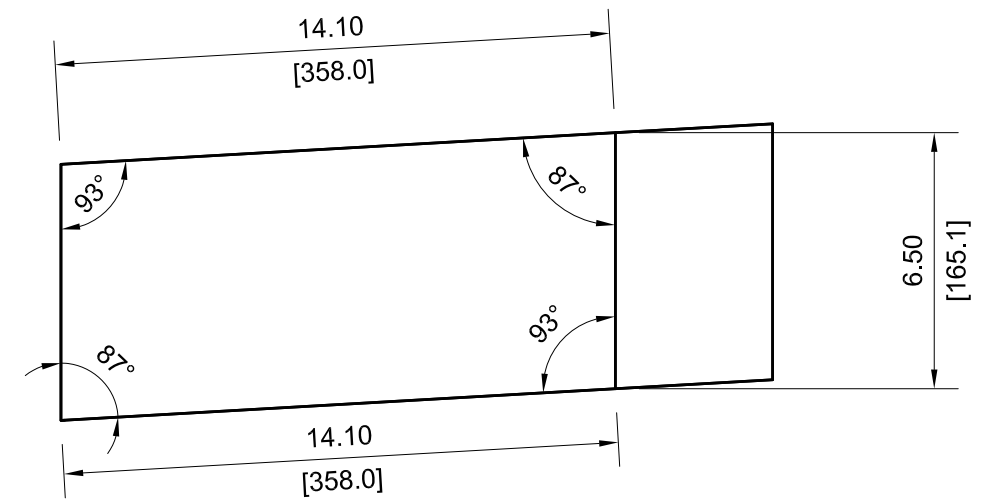

VIEW A6-127

NOTE: ALL VIEWS TAKEN AS TRUE VIEWS PARALLEL TO SURFACE OF PART

		DRAWING NUMBER			
		AES-D0002			
SIZE	SCALE	SHEET	OF	REVISION	
A3	NONE	127	167	F	

-319

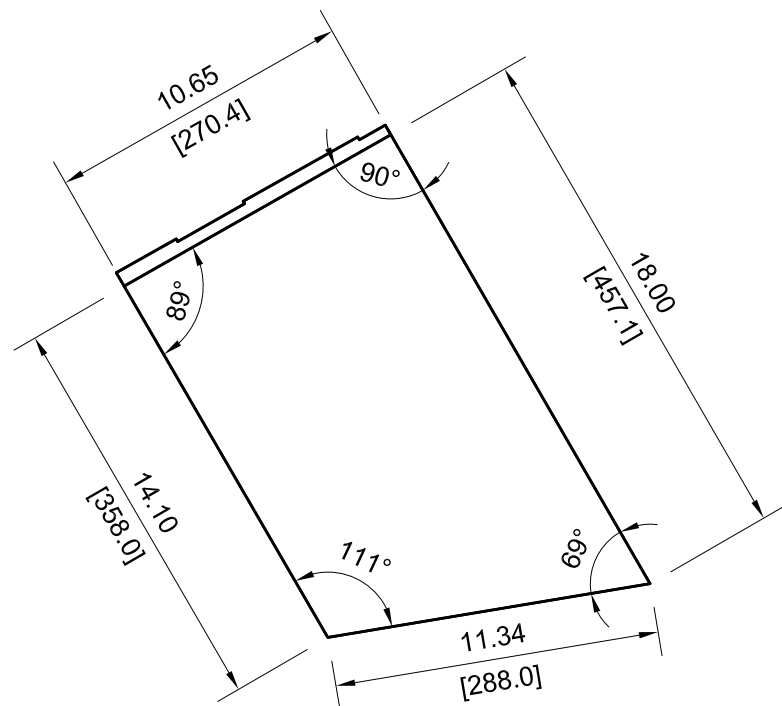

VIEW D4-128

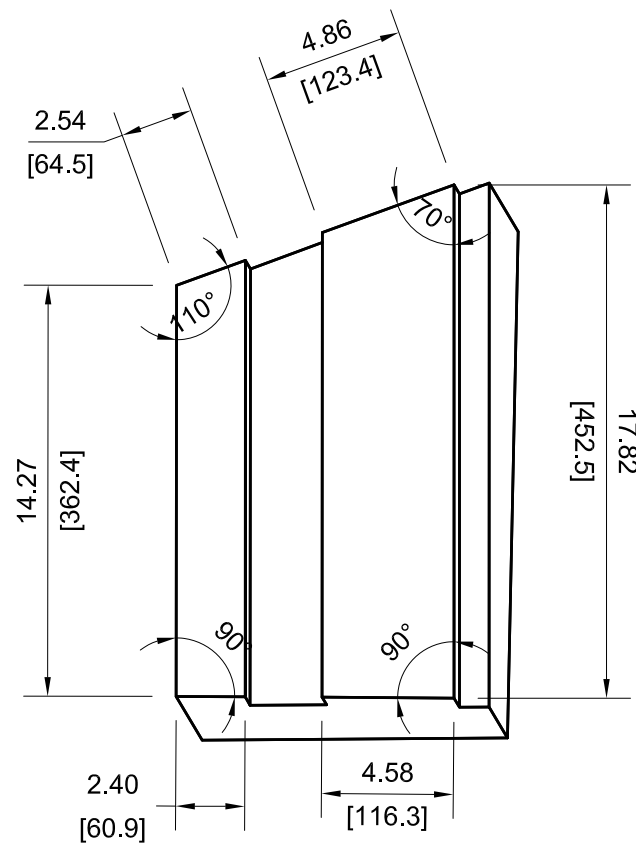

VIEW F4-128

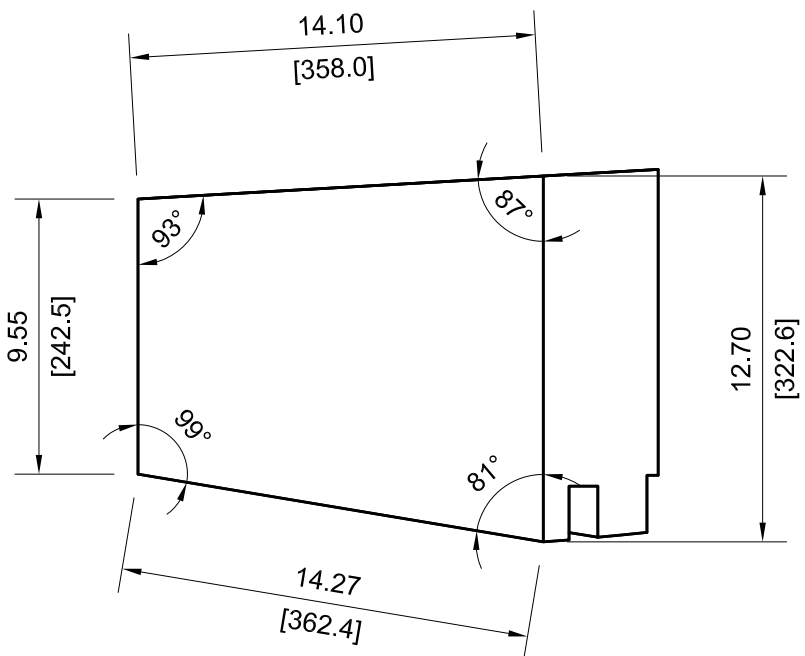
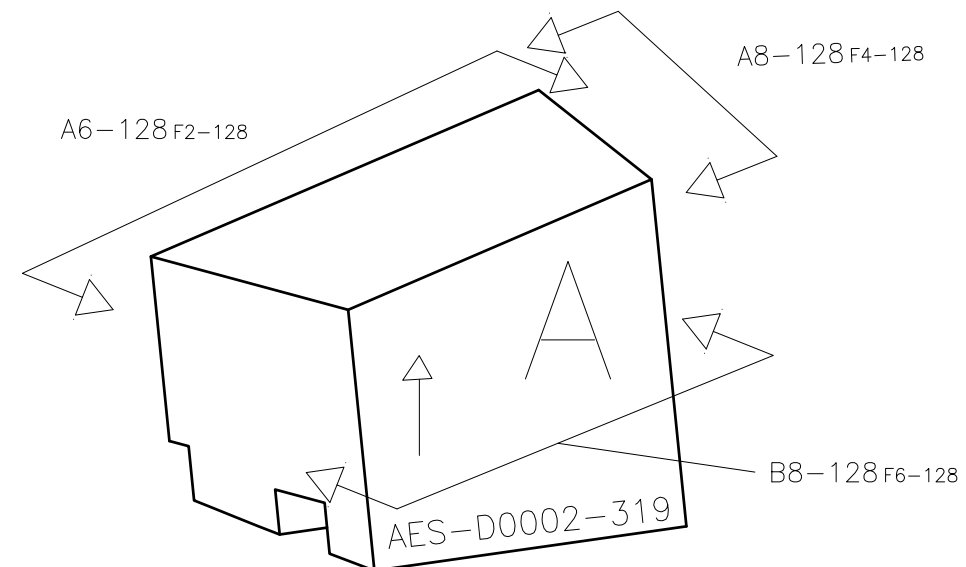

VIEW B8-128

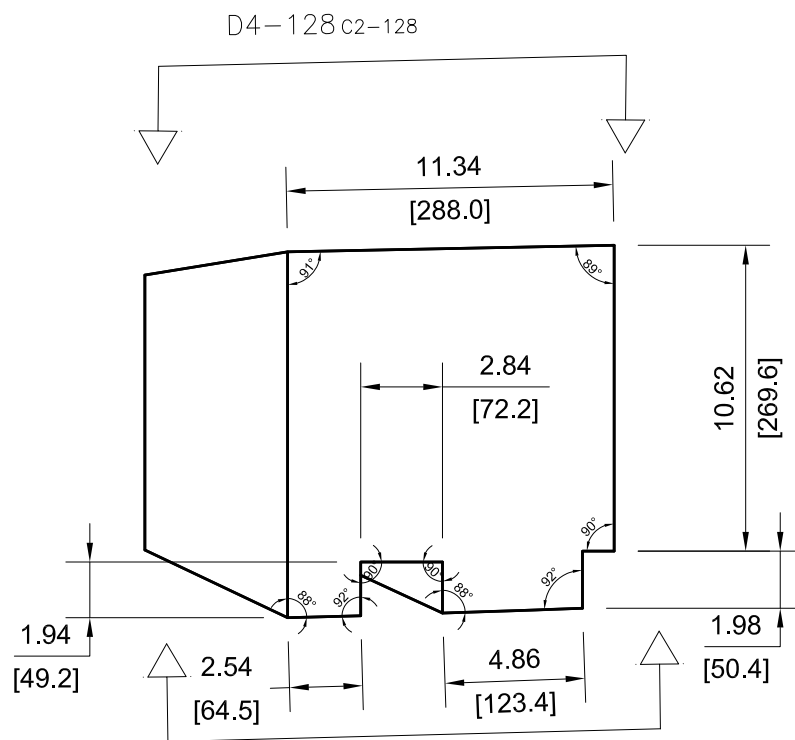

VIEW A8-128

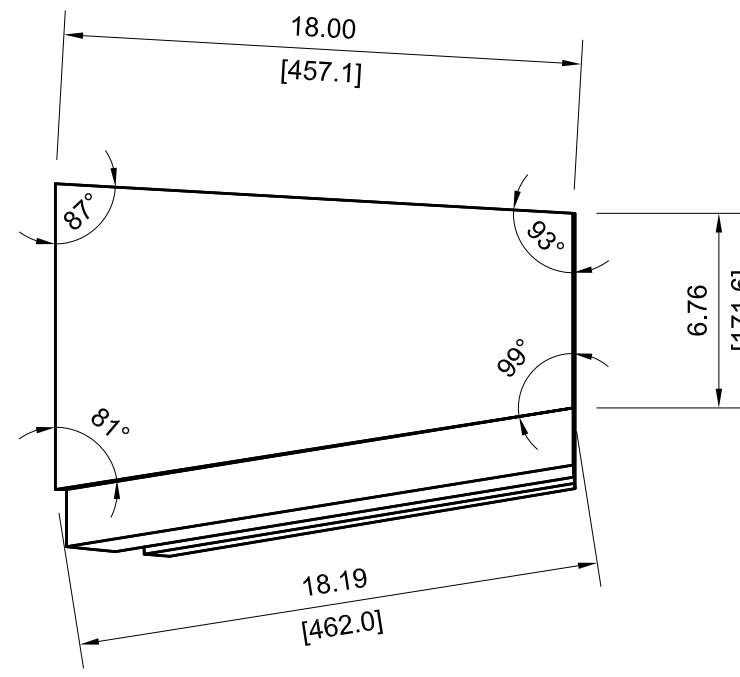

VIEW A6-128

NOTE: ALL VIEWS TAKEN AS TRUE VIEWS PARALLEL TO SURFACE OF PART

		DRAWING NUMBER			
		AES-D0002			
SIZE	SCALE	SHEET	OF	REVISION	
A3	NONE	128	167	F	

-321

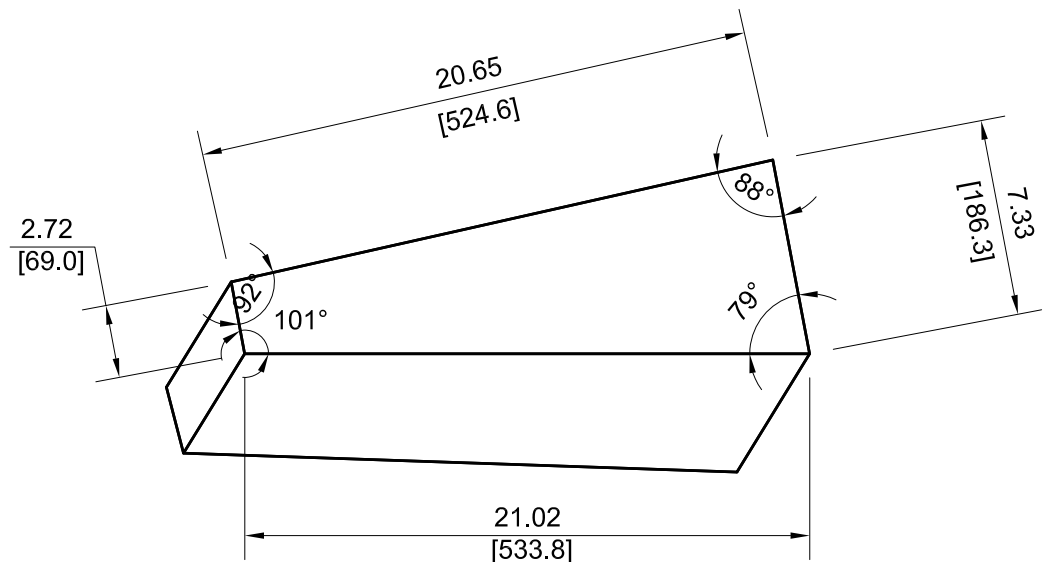

VIEW F3-129

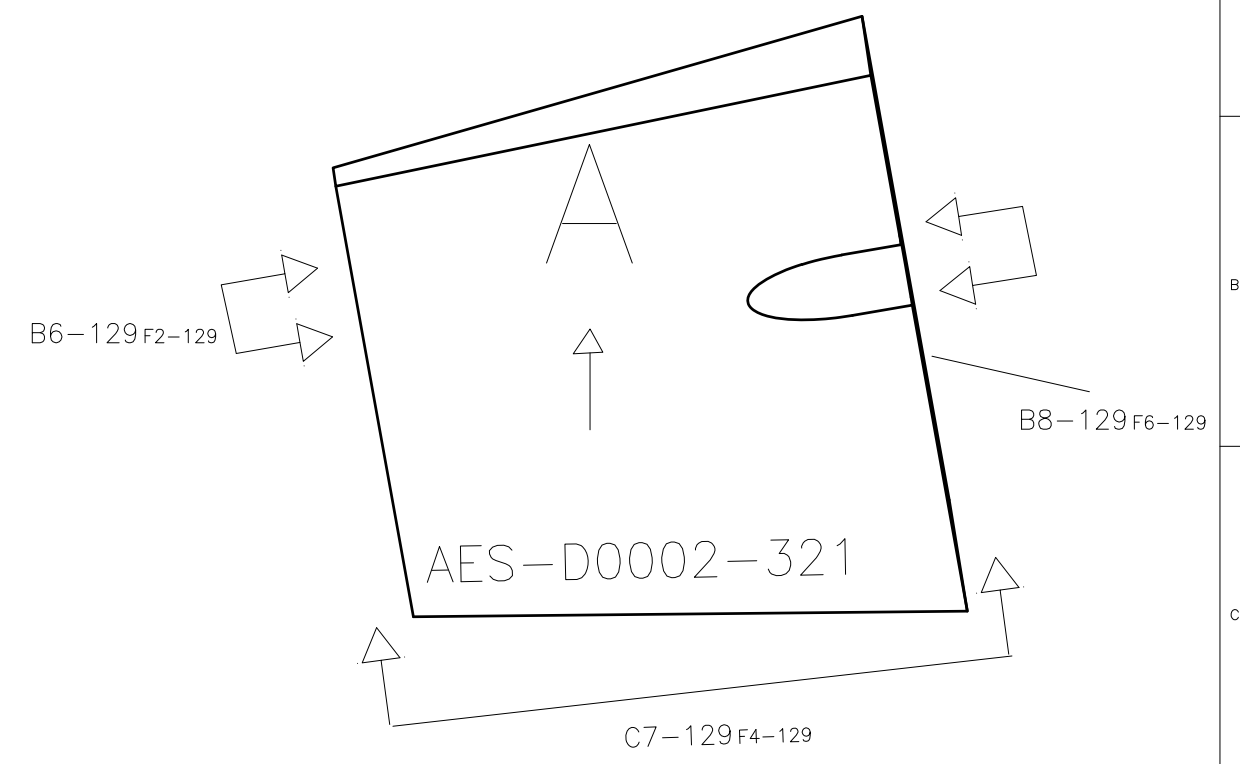

C7-129F4-129

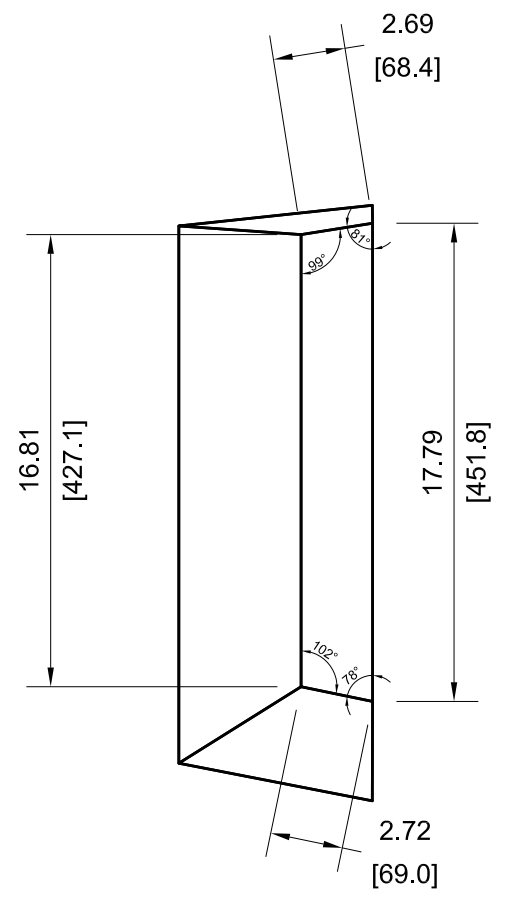

VIEW B6-129

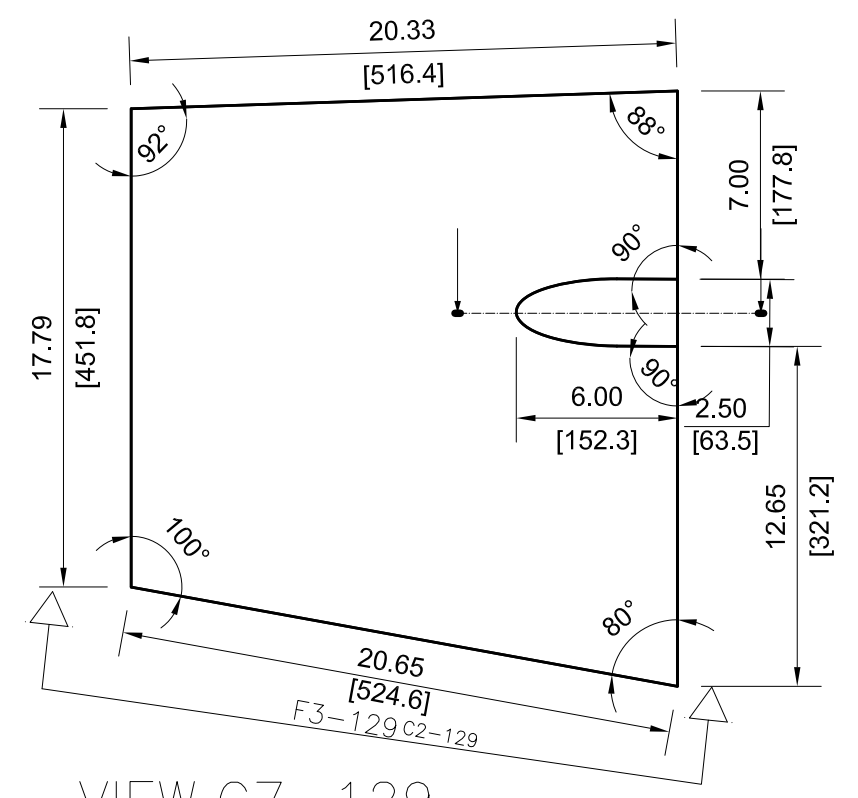

VIEW C7-129

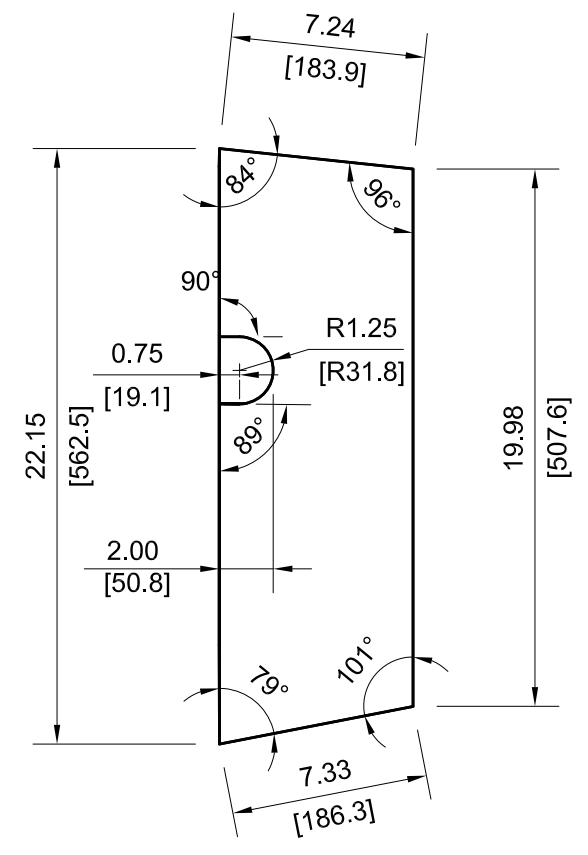

VIEW B8-129

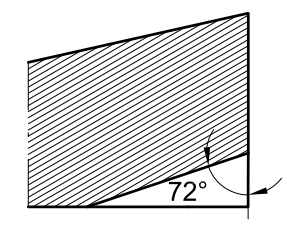

NOTE: ALL VIEWS TAKEN AS TRUE VIEWS PARALLEL TO SURFACE OF PART

		DRAWING NUMBER			
		AES-D0002			
SIZE	SCALE	SHEET	OF	REVISION	
A3	NONE	129	167	F	

-323

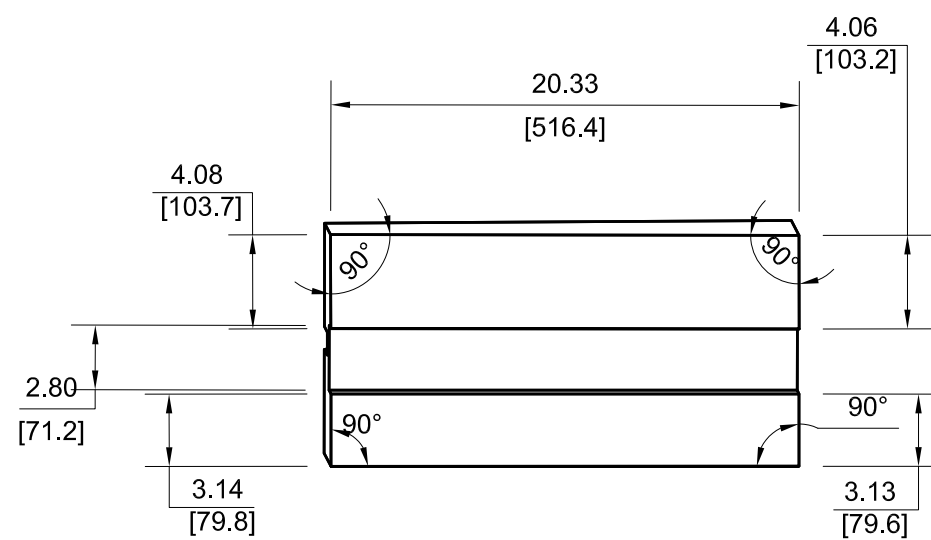

VIEW D4-130

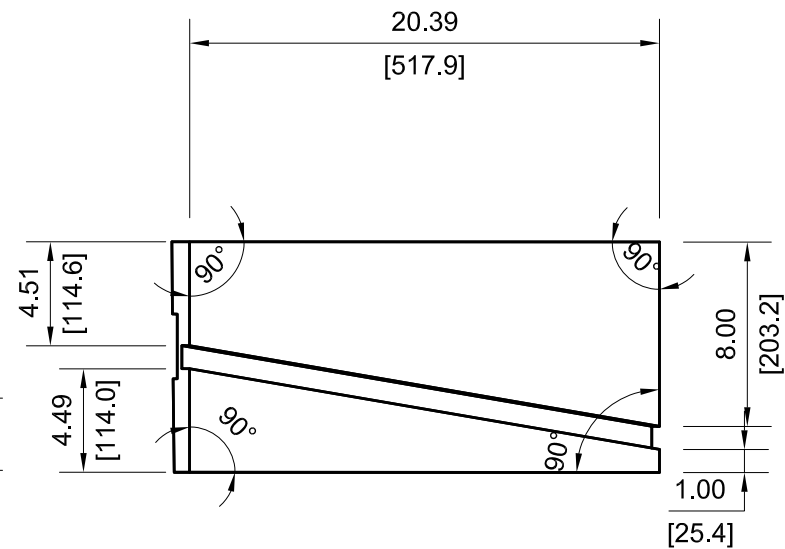

VIEW F4-130

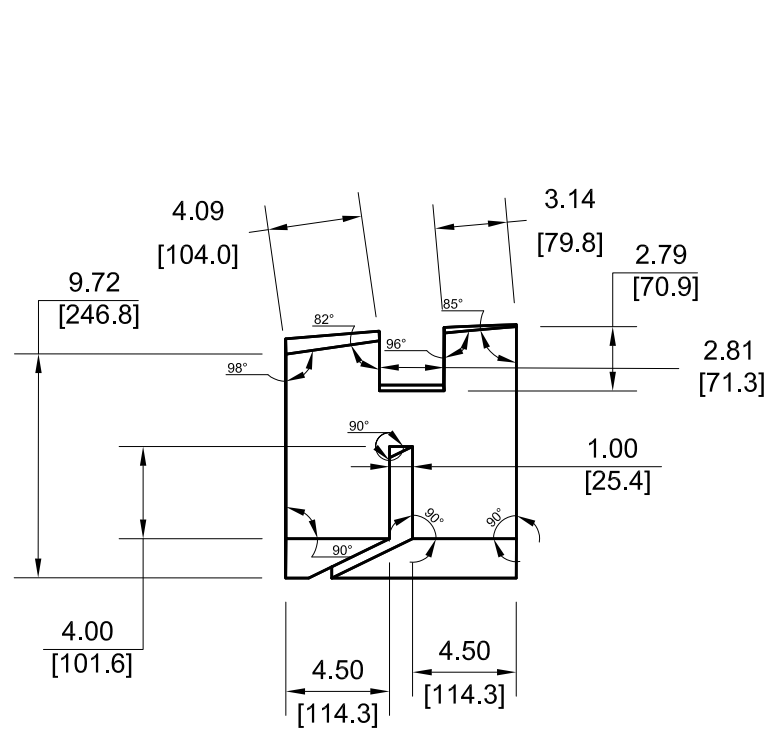
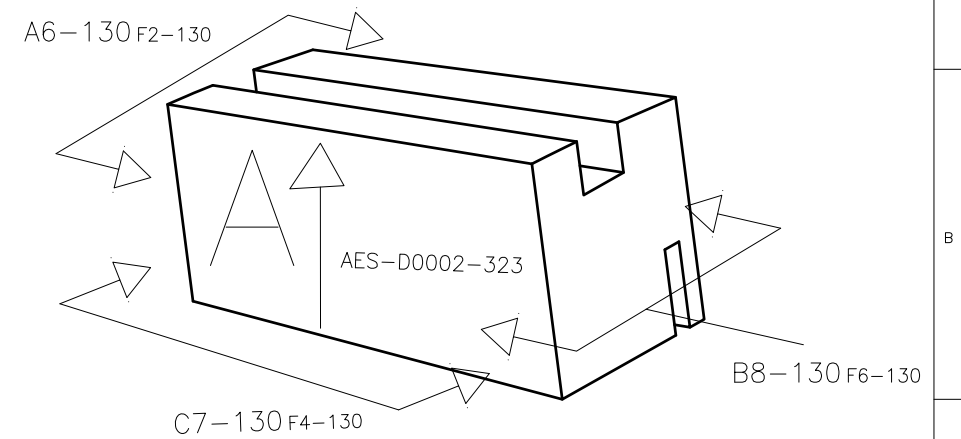

VIEW A6-130

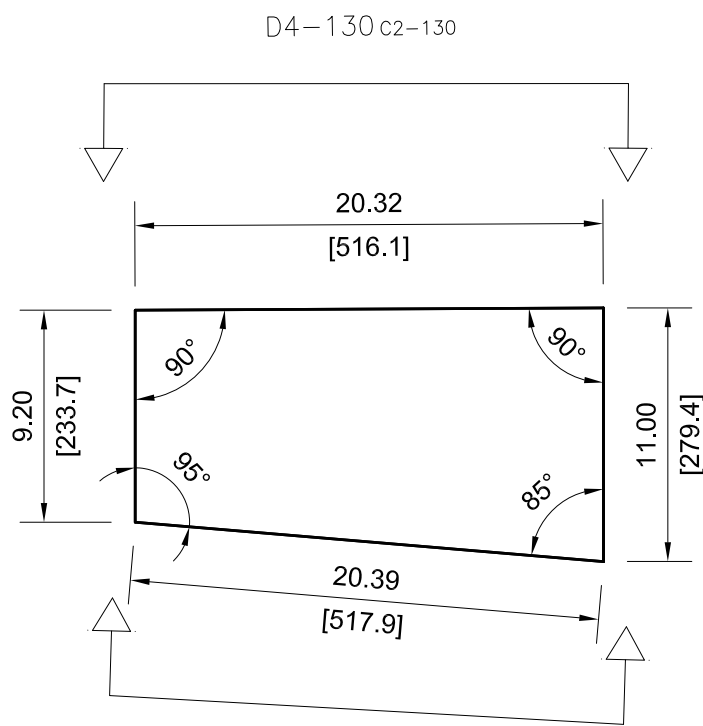

VIEW C7-130

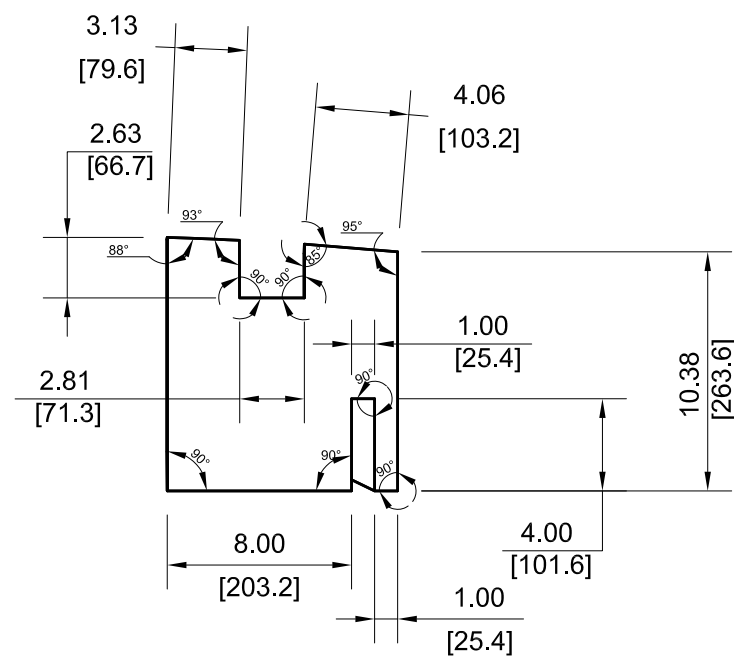

VIEW B8-130

NOTE: ALL VIEWS TAKEN AS TRUE VIEWS PARALLEL TO SURFACE OF PART

		DRAWING NUMBER			
		AES-D0002			
SIZE	SCALE	SHEET	OF	REVISION	
A3	NONE	130	167	F	

-325

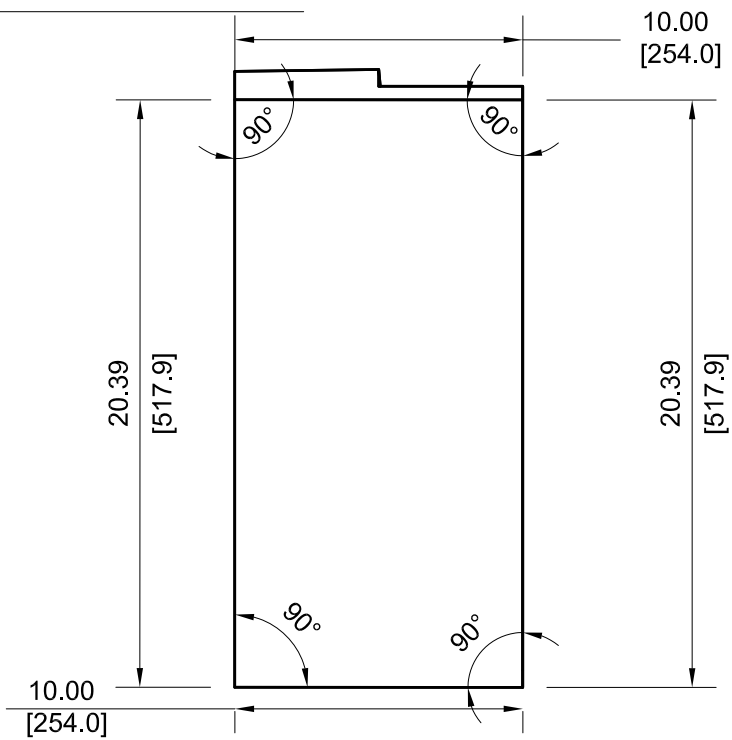

VIEW D4-131

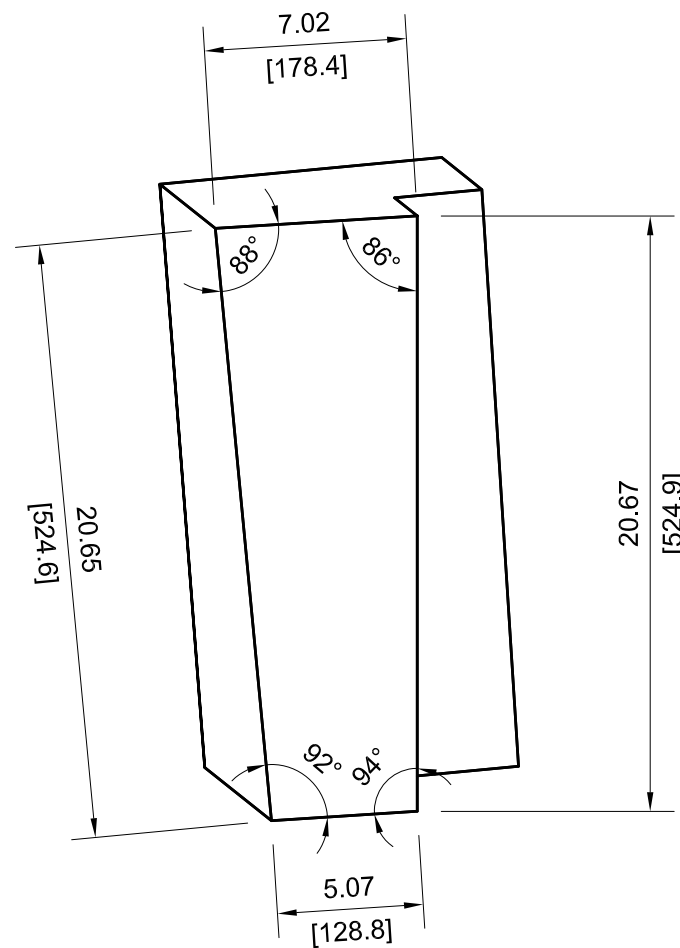

VIEW F4-131

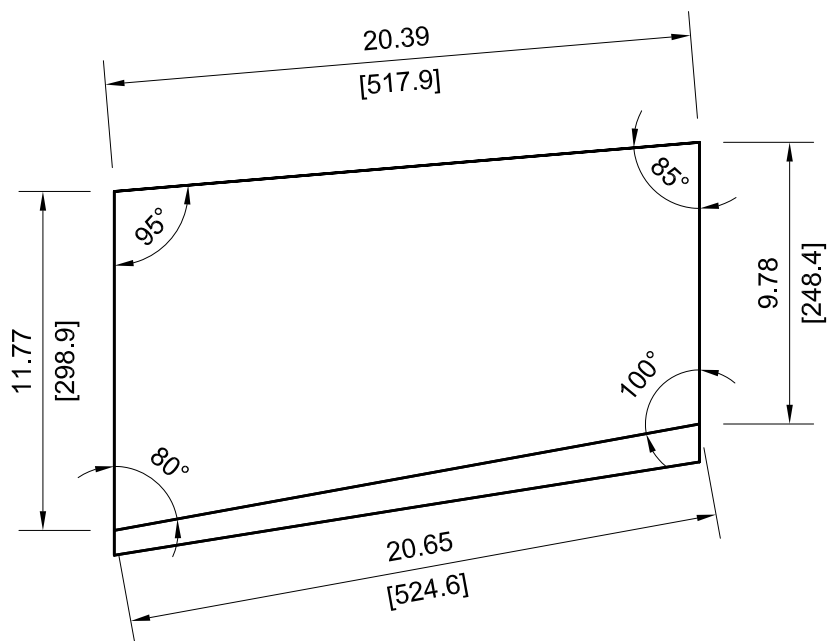
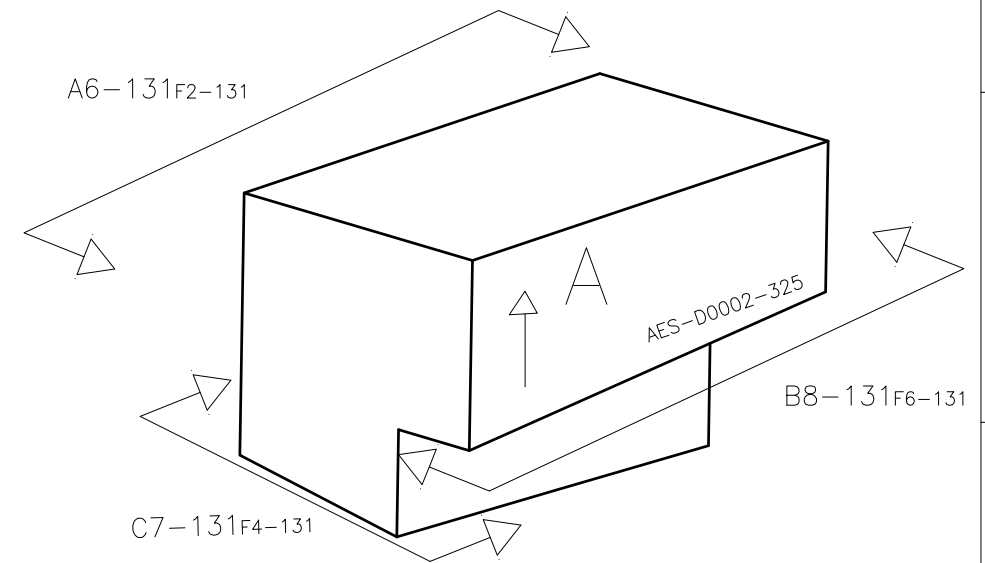

VIEW A6-131

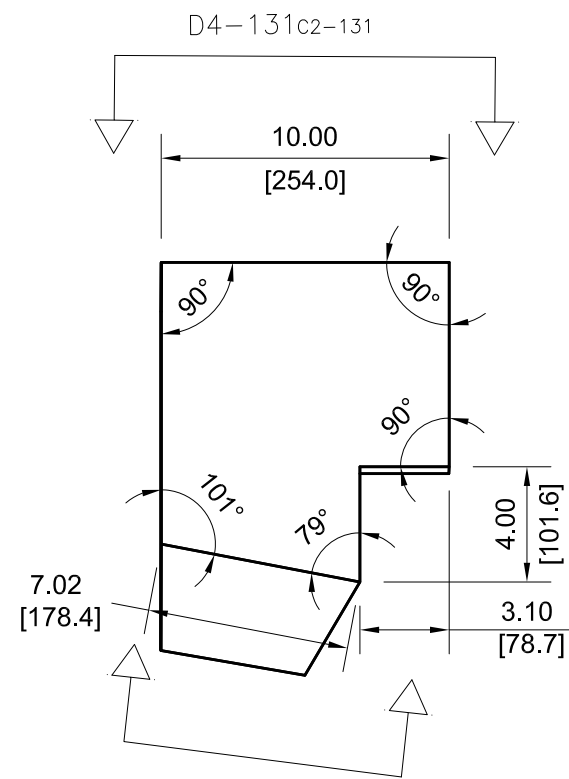

VIEW C7-131

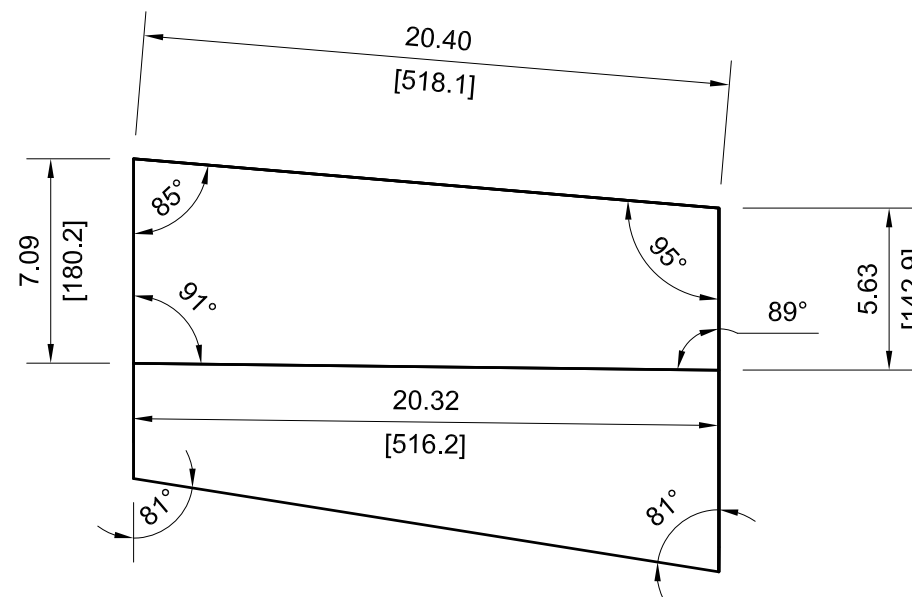

VIEW B8-131

NOTE: ALL VIEWS TAKEN AS TRUE VIEWS PARALLEL TO SURFACE OF PART

		DRAWING NUMBER			
		AES-D0002			
SIZE	SCALE	SHEET	OF	REVISION	
A3	NONE	131	167	F	

-327

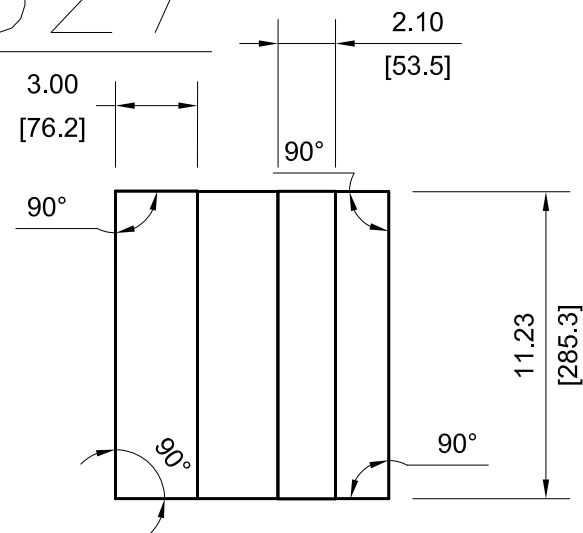

VIEW C4-132

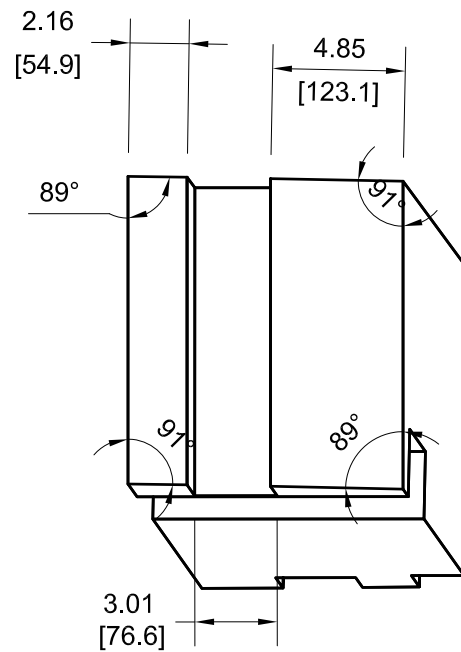

VIEW F4-132

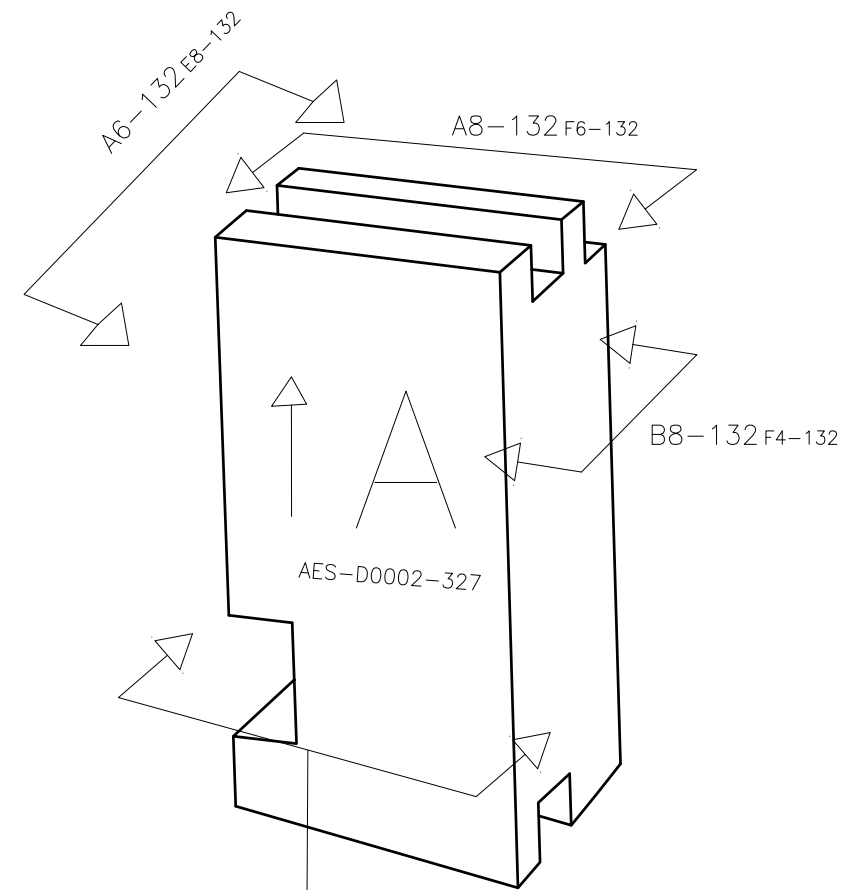

VIEW A6-132

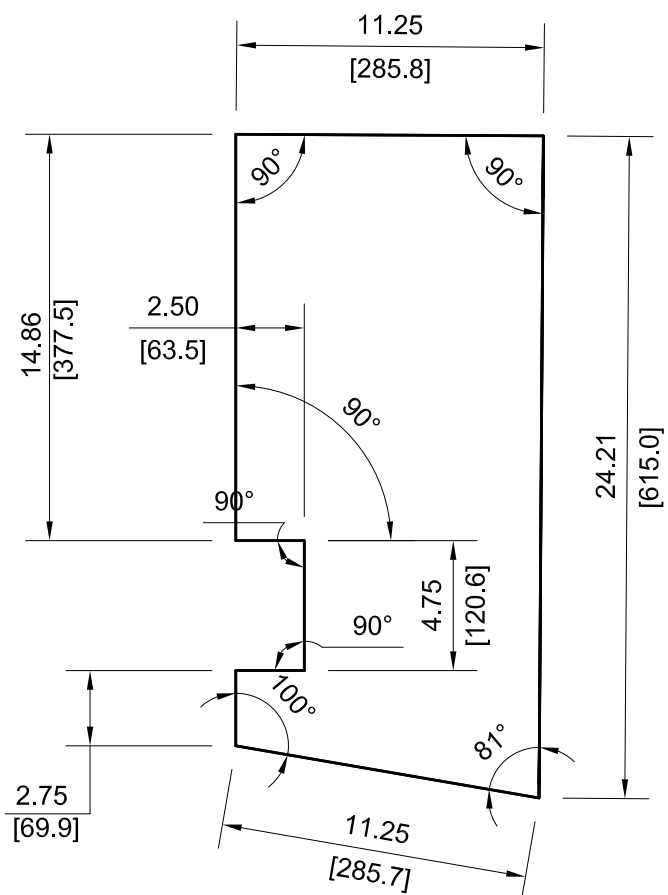

VIEW D7-132

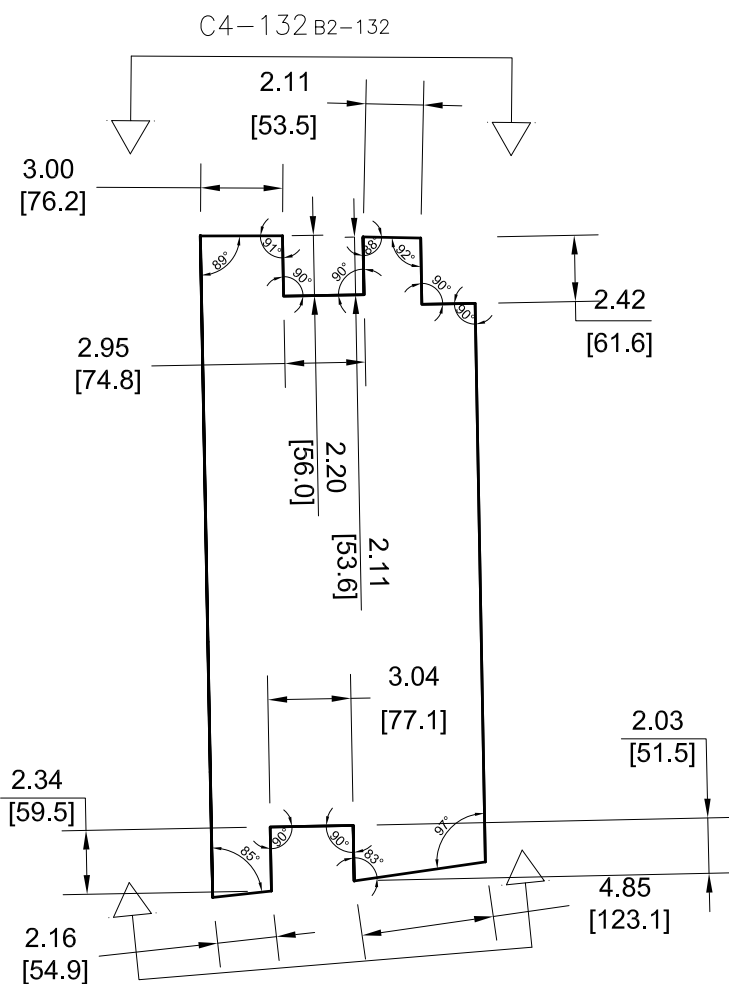

VIEW B8-132

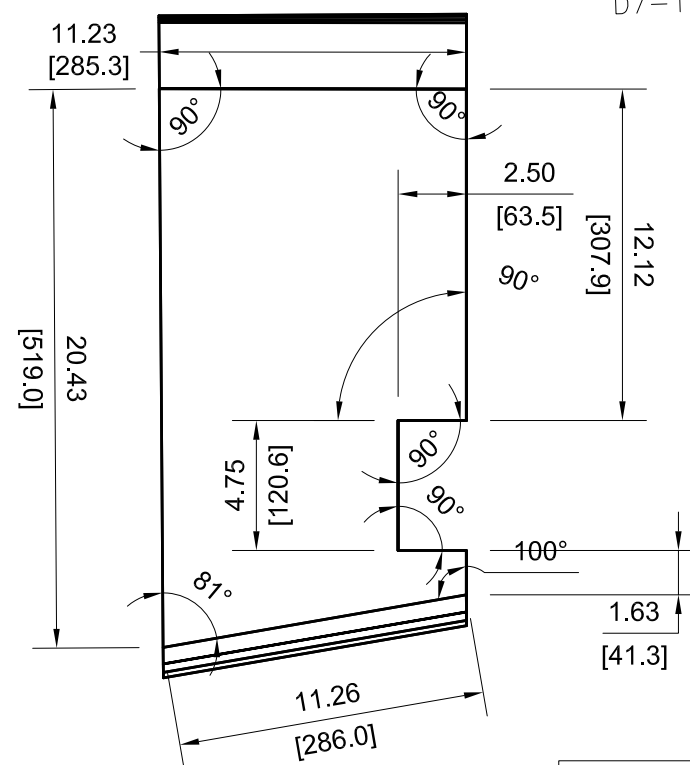

VIEW A8-132

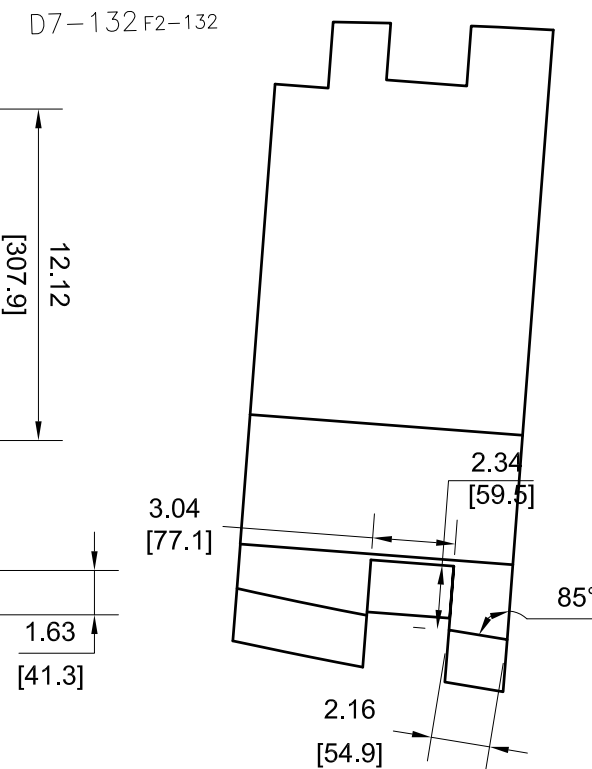

F4-132 C5-132

NOTE: ALL VIEWS TAKEN AS TRUE VIEWS PARALLEL TO SURFACE OF PART

		DRAWING NUMBER			
		AES-D0002			
SIZE	SCALE	SHEET	OF	REVISION	
A3	NONE	132	167	F	

-329

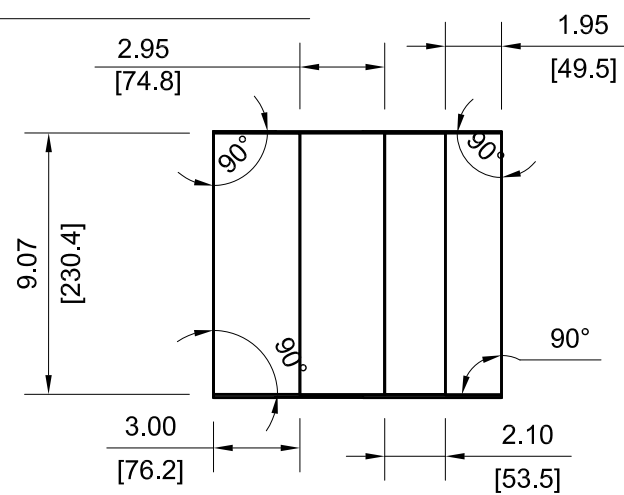

VIEW C4-133

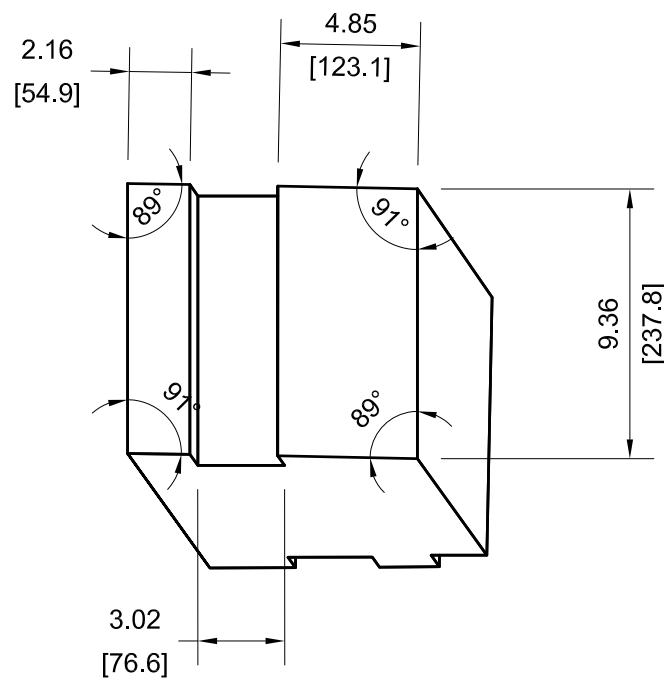

VIEW F4-133

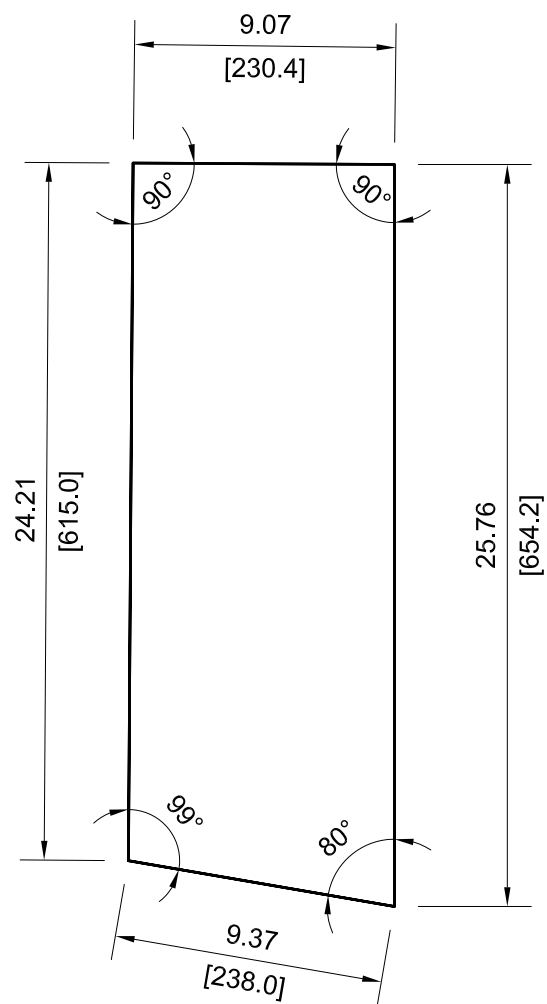
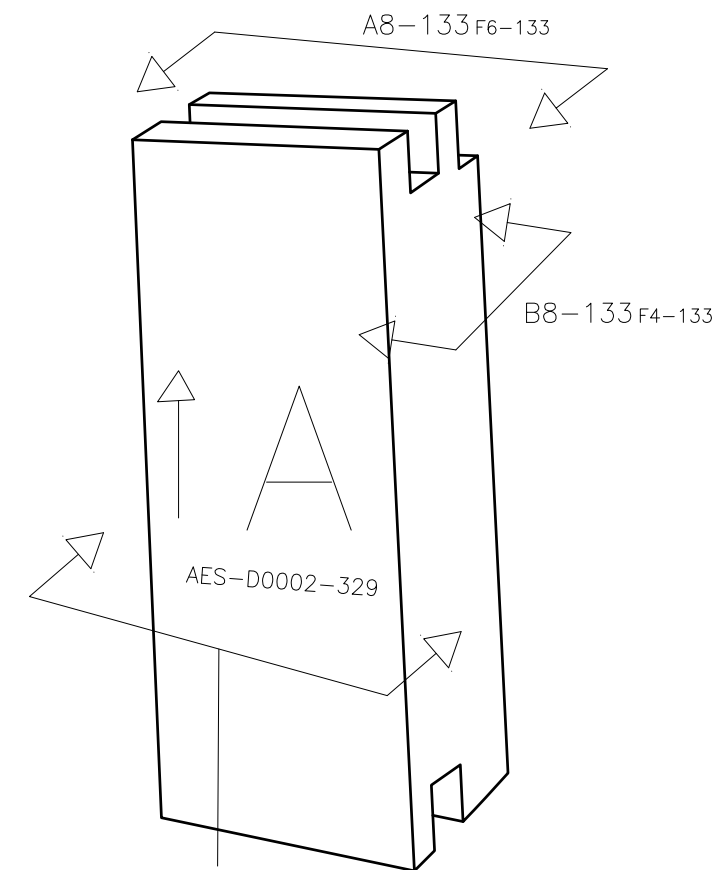

VIEW D7-133

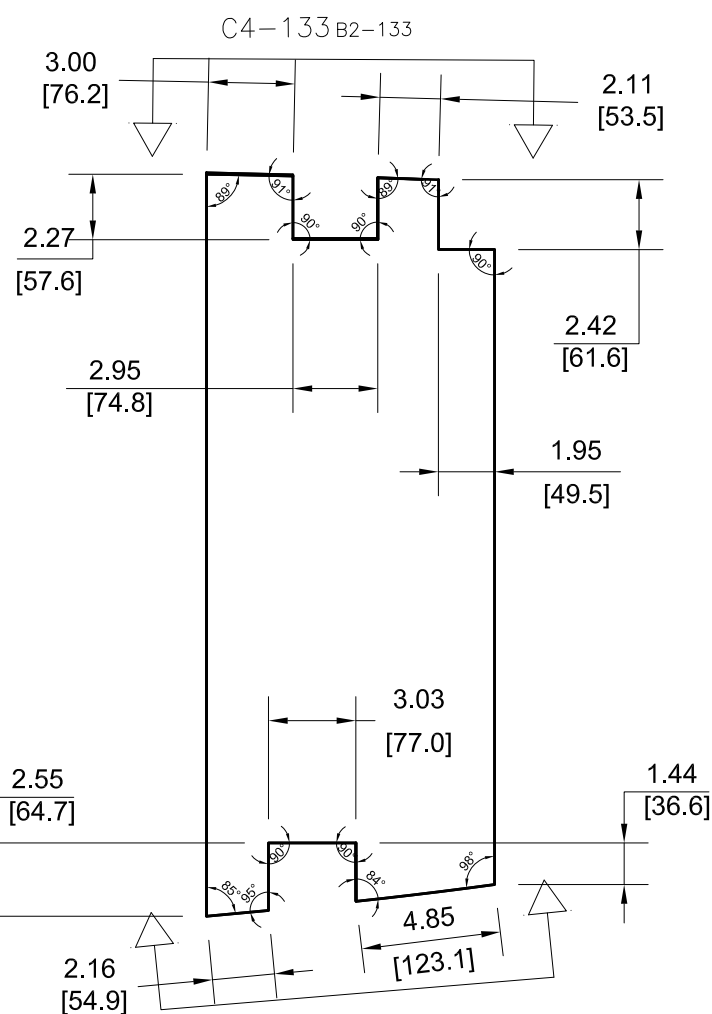

VIEW B8-133

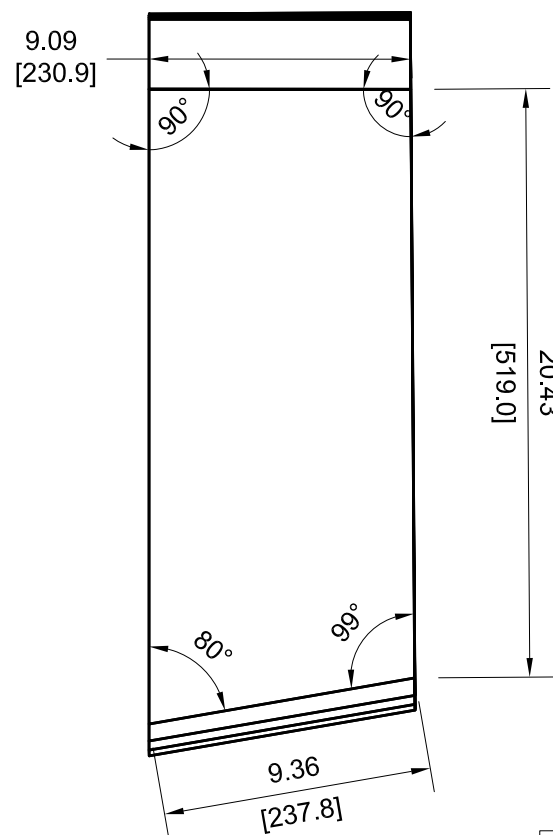

VIEW A8-133

NOTE: ALL VIEWS TAKEN AS TRUE VIEWS PARALLEL TO SURFACE OF PART

		DRAWING NUMBER			
		AES-D0002			
SIZE	SCALE	SHEET	OF	REVISION	
A3	NONE	133	167	F	

— 333

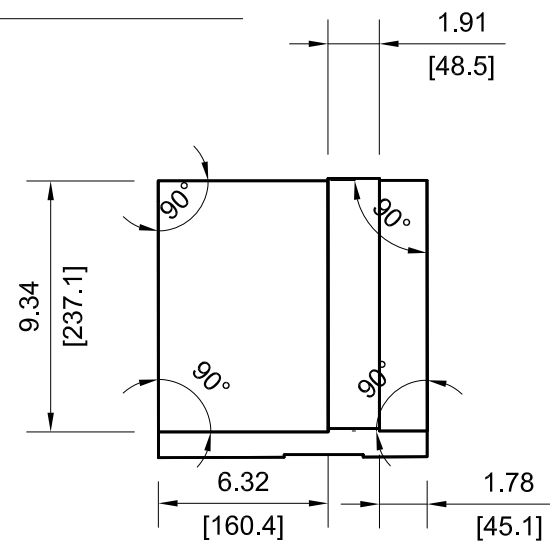

VIEW C4-135

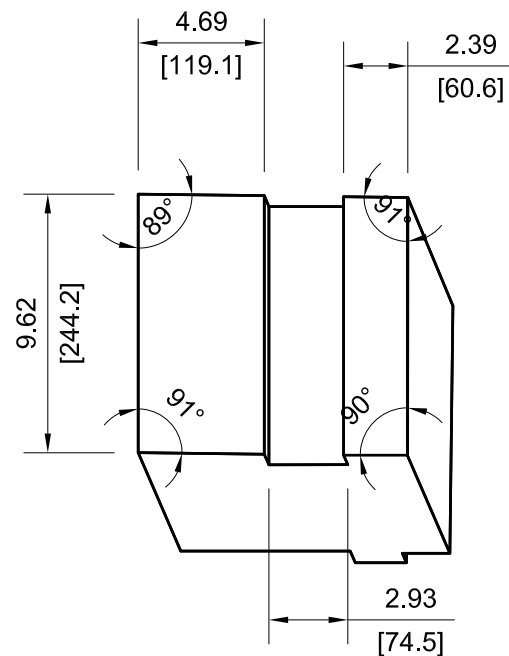

VIEW F4-135

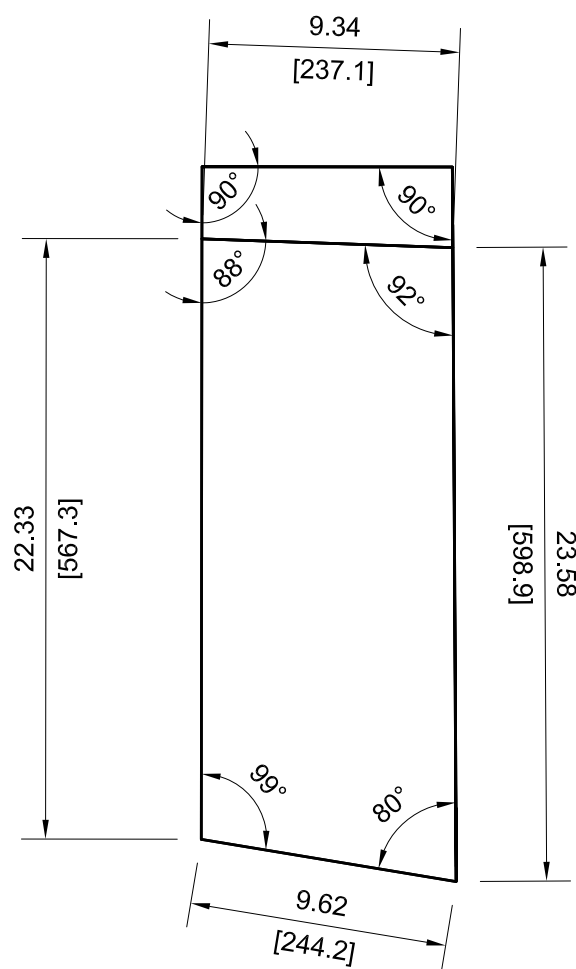
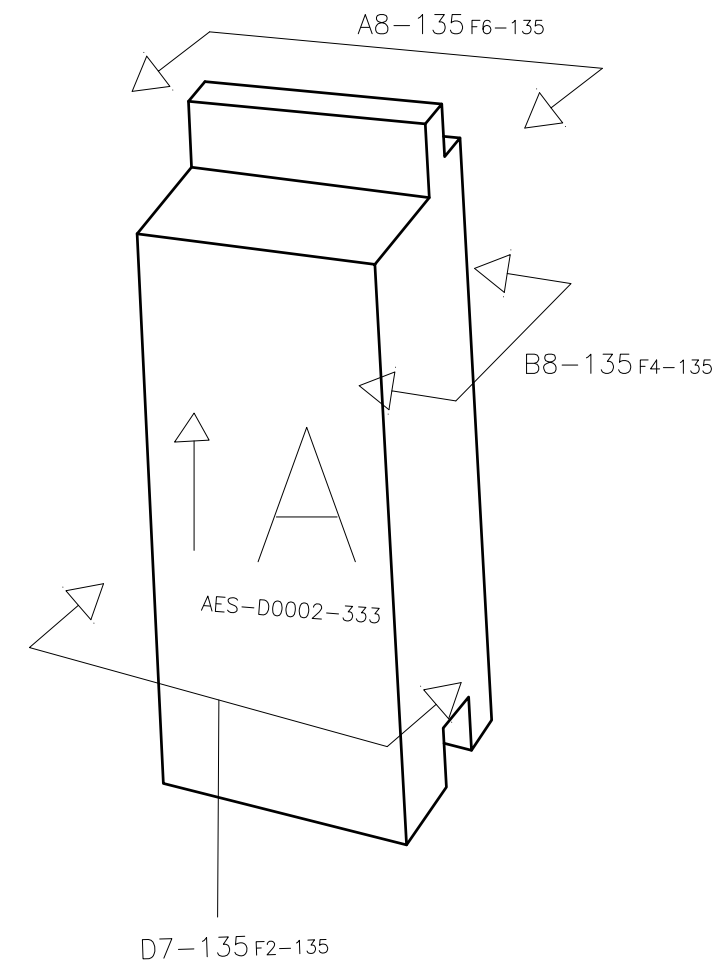

VIEW D7-135

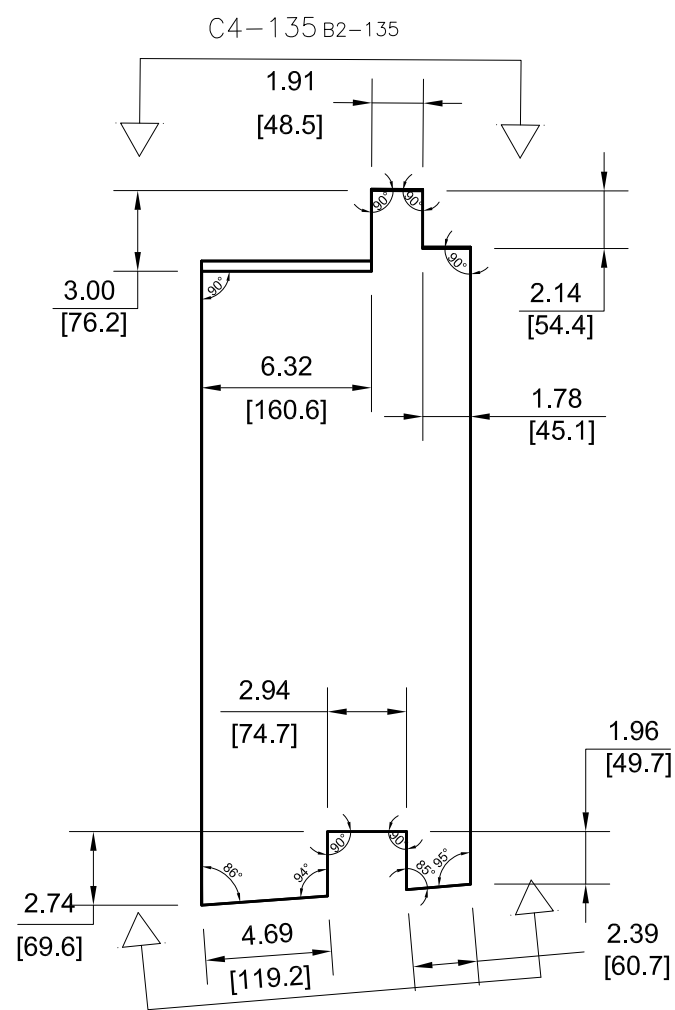

VIEW B8-135

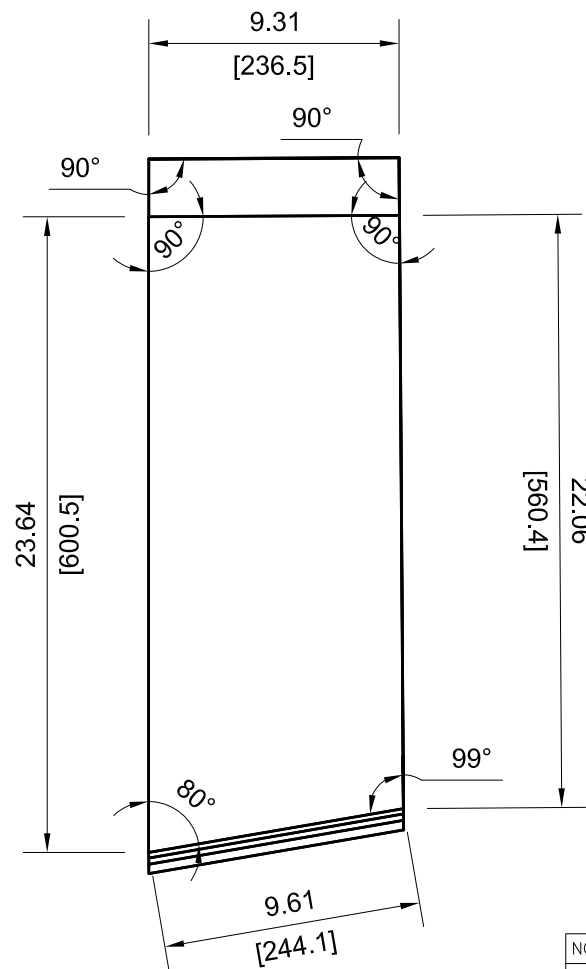

VIEW A8-135

NOTE: ALL VIEWS TAKEN AS TRUE VIEWS PARALLEL TO SURFACE OF PART

		DRAWING NUMBER			
		AES-D0002			
SIZE	SCALE	SHEET	OF	REVISION	
A3	NONE	135	167	F	

- 335

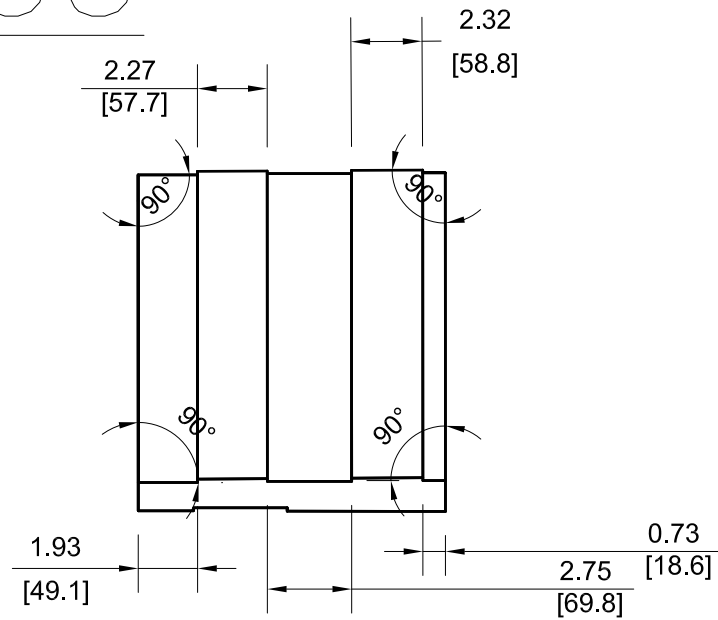

VIEW C4-136

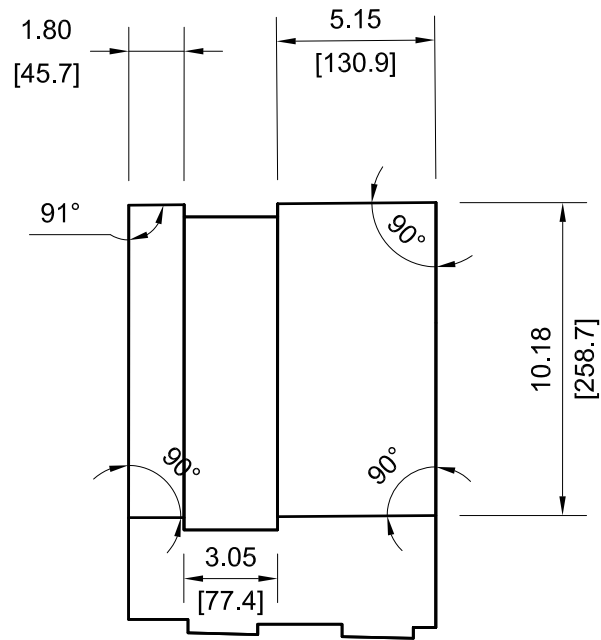

VIEW F4-136

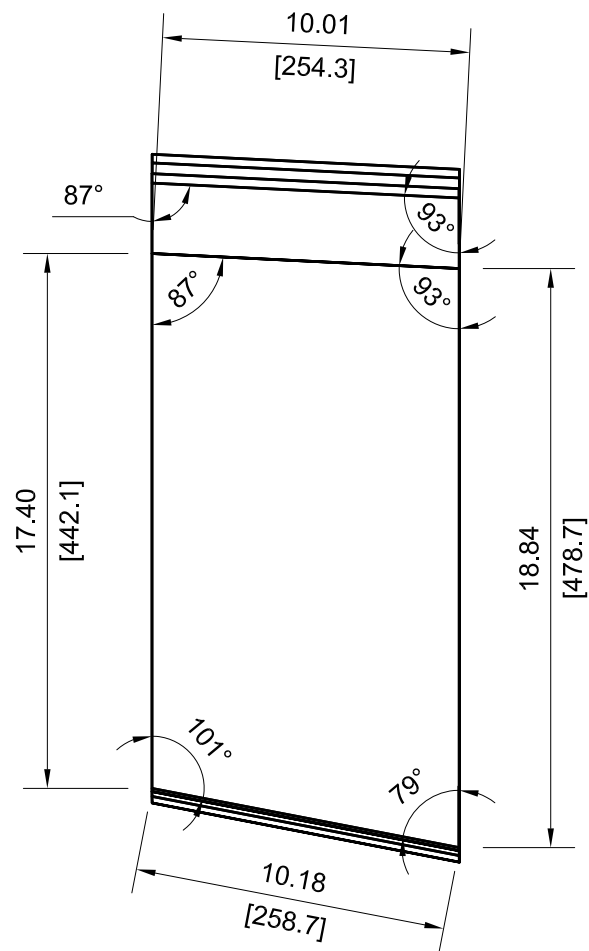
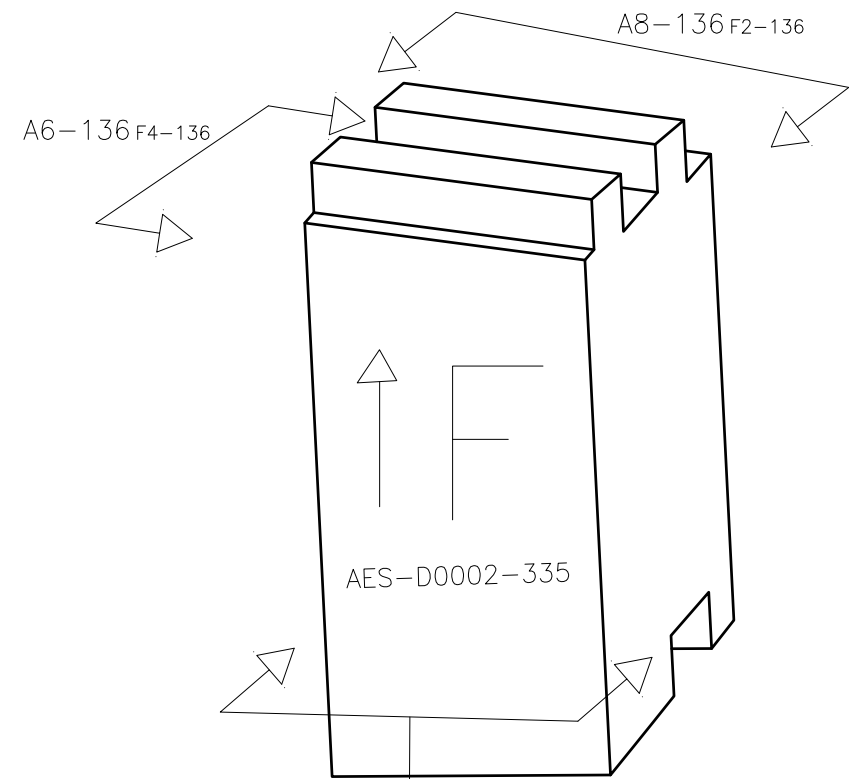

VIEW A8-136

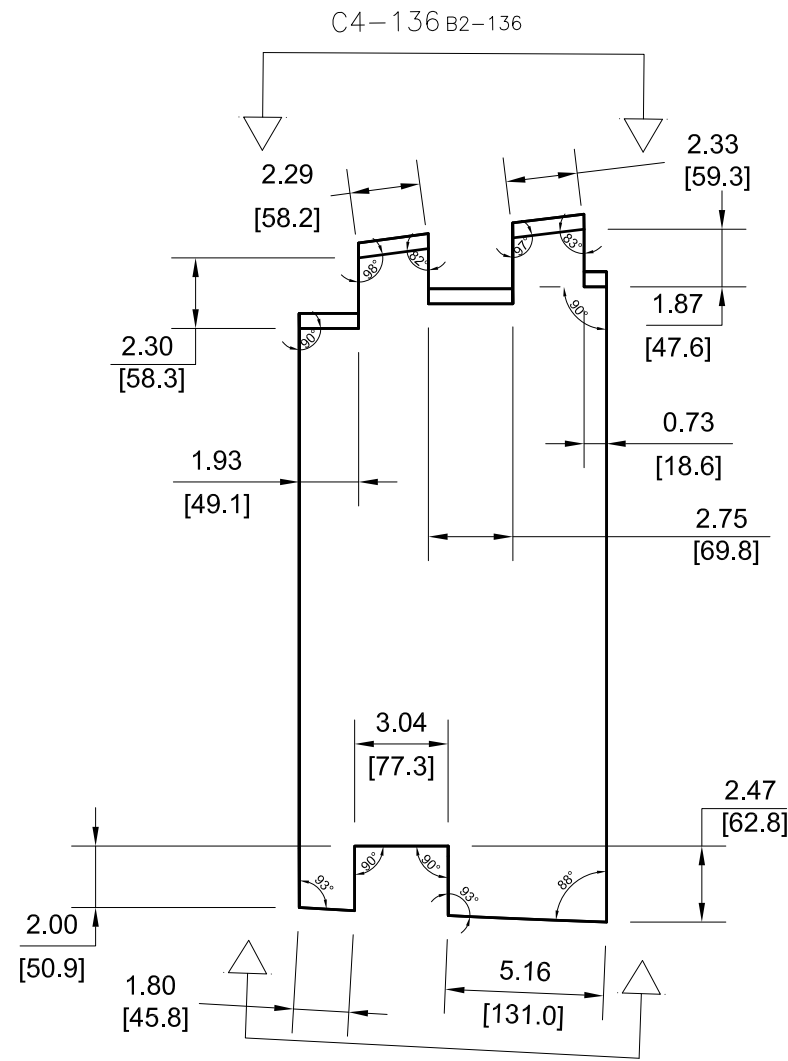

VIEW A6-136

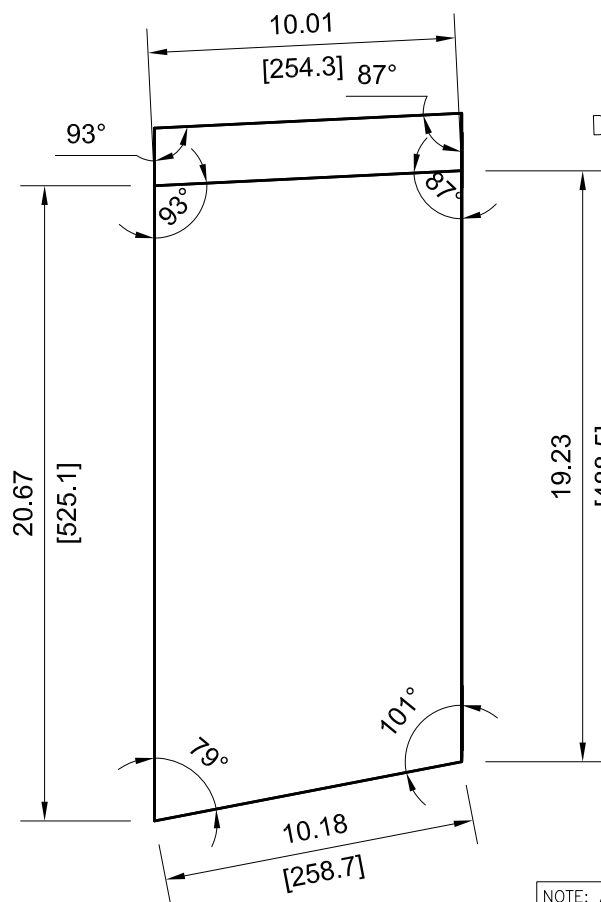

VIEW D7-136

NOTE: ALL VIEWS TAKEN AS TRUE VIEWS PARALLEL TO SURFACE OF PART

		DRAWING NUMBER			
		AES-D0002			
SIZE	SCALE	SHEET	OF	REVISION	
A3	NONE	136	167	F	

- 337

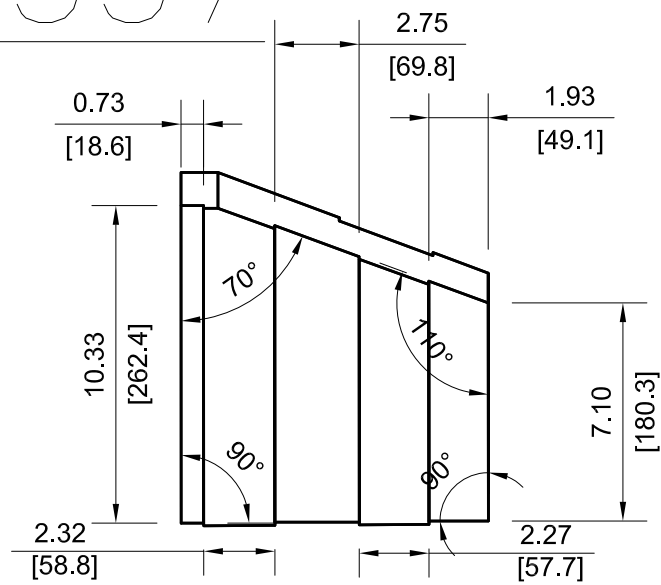

VIEW C4-137

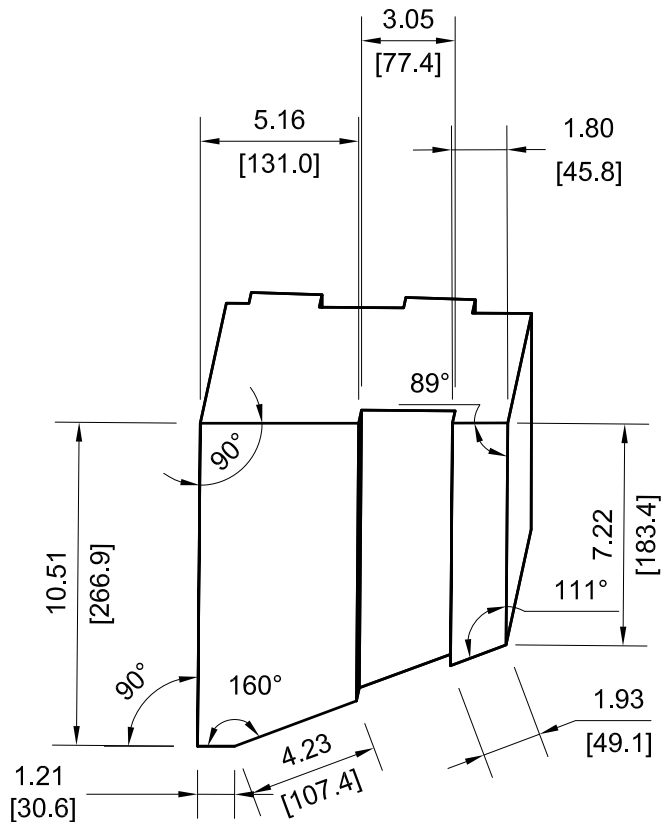

VIEW F4-137

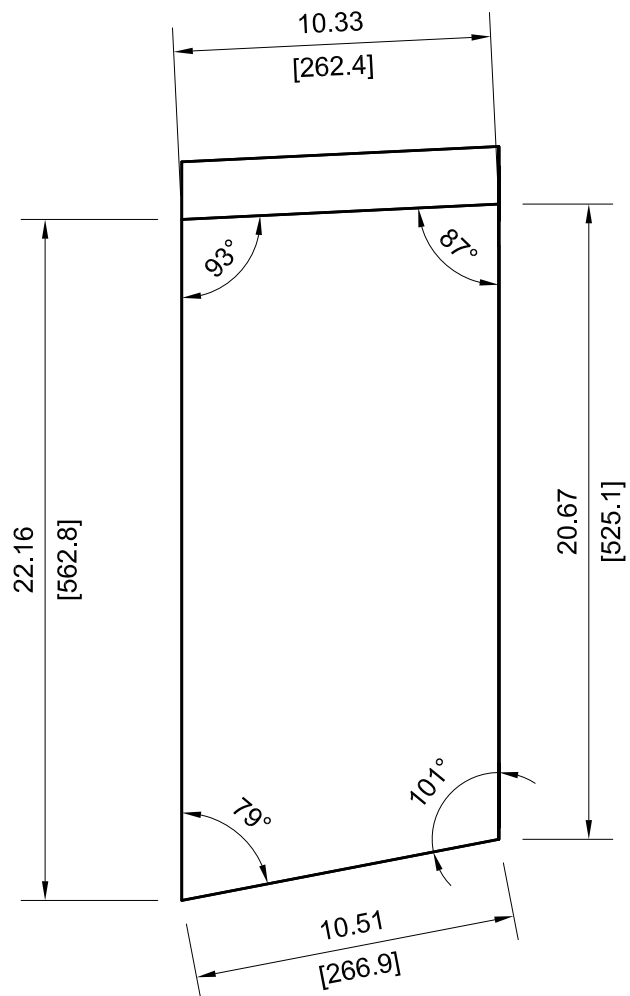
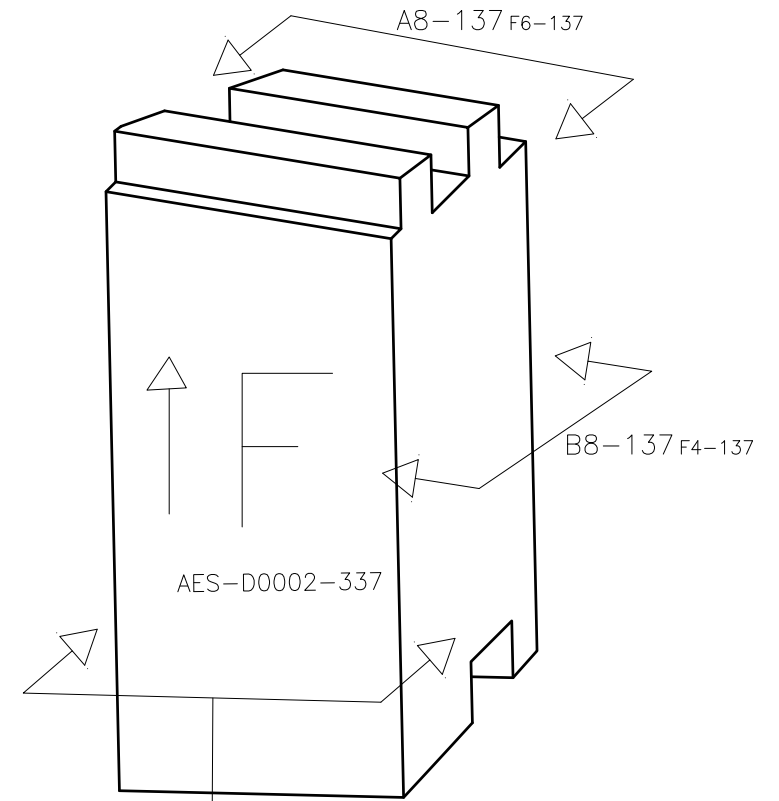

VIEW D7-137

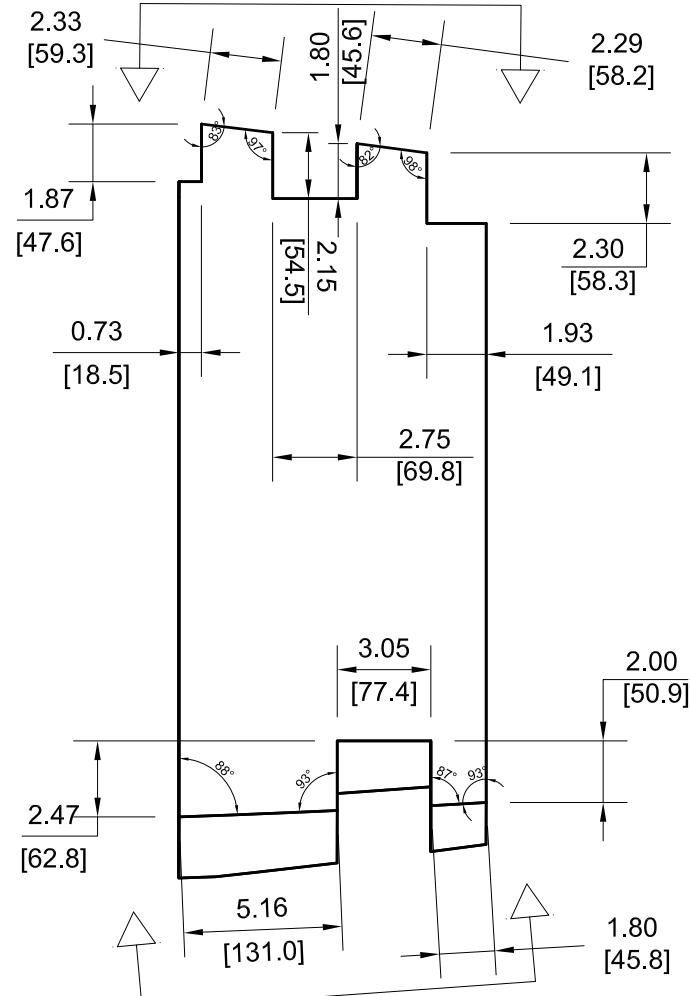

VIEW B8-137

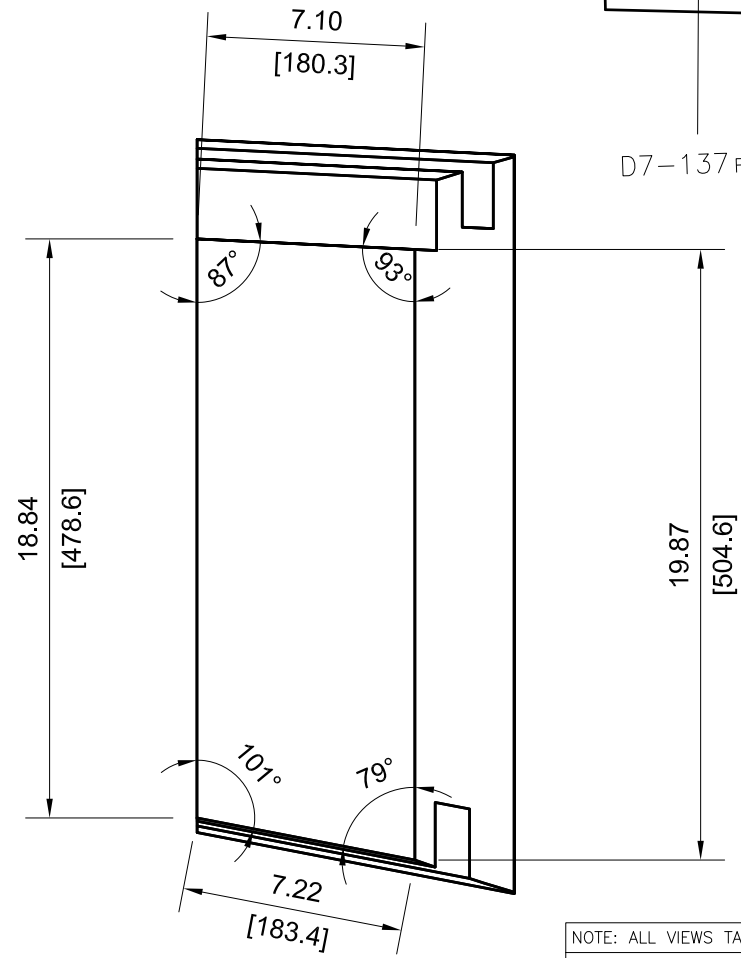

VIEW A8-137

NOTE: ALL VIEWS TAKEN AS TRUE VIEWS PARALLEL TO SURFACE OF PART

		DRAWING NUMBER			
		AES-D0002			
SIZE	SCALE	SHEET	OF	REVISION	
A3	NONE	137	167	F	

339

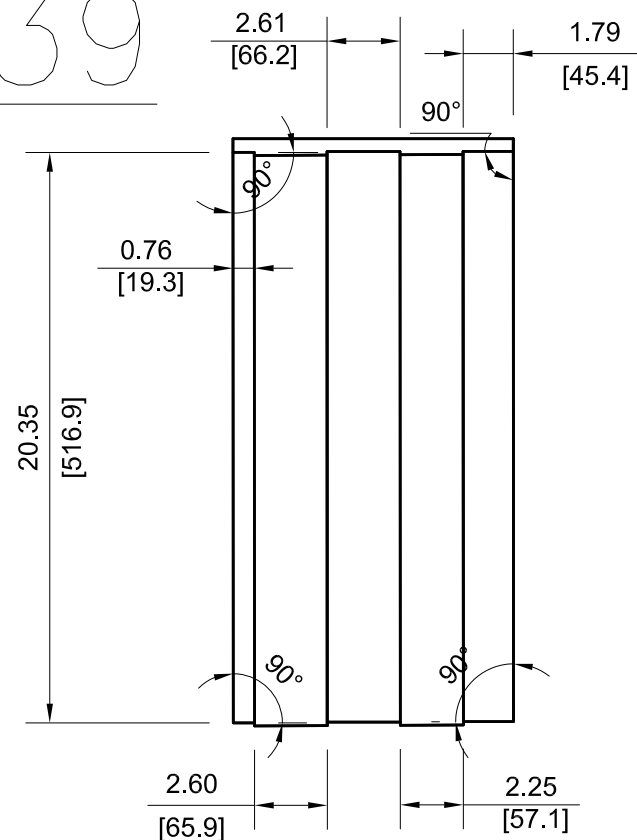

VIEW C4-138

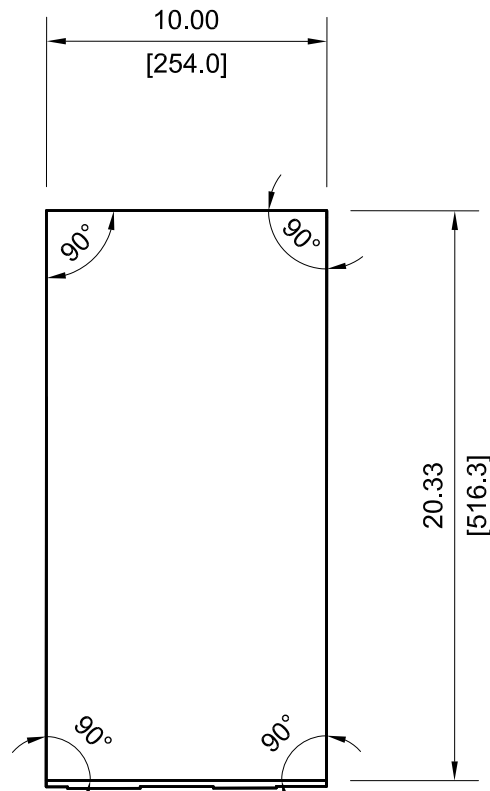

VIEW F4-138

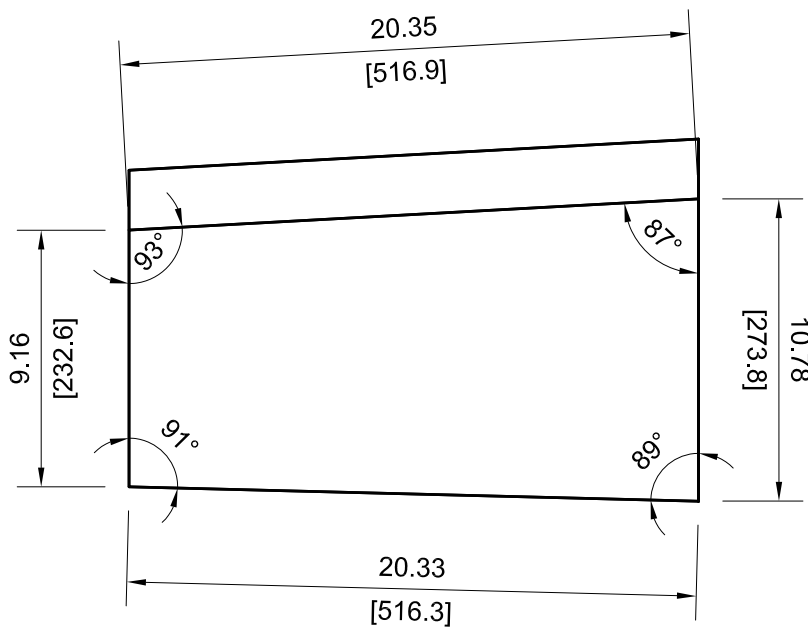
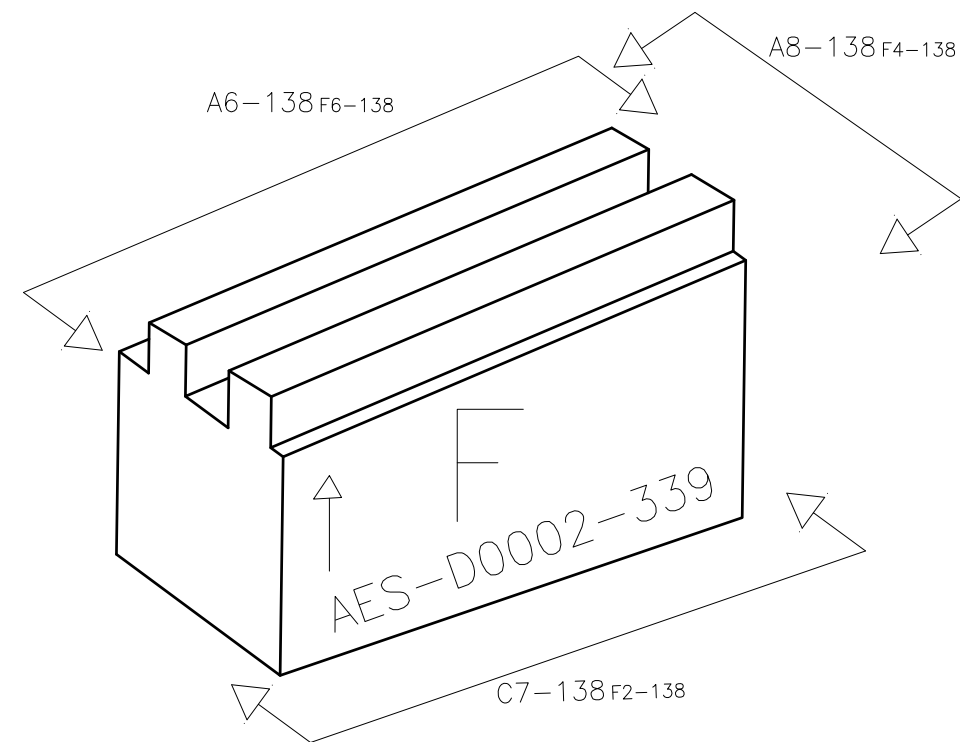

VIEW C7-138

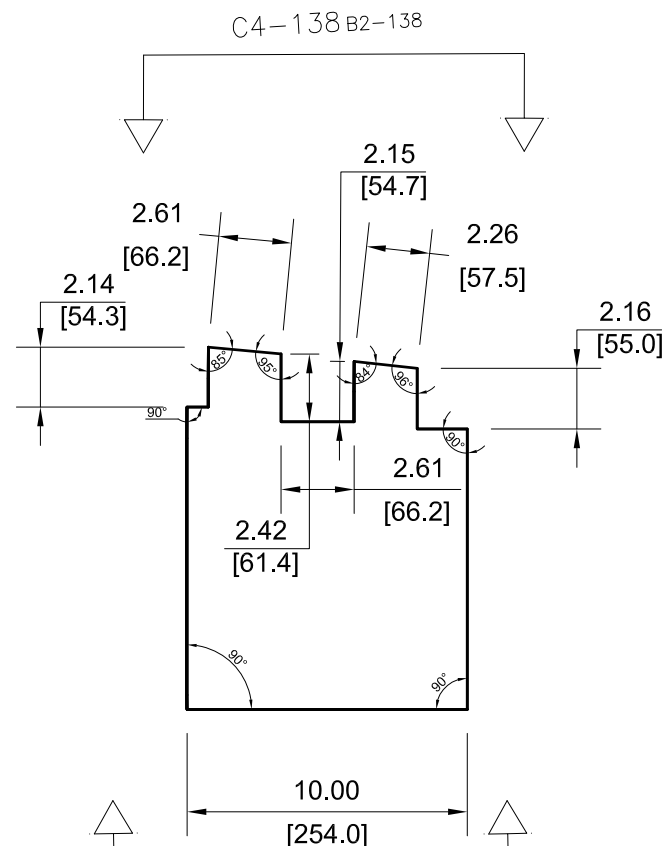

VIEW A8-138

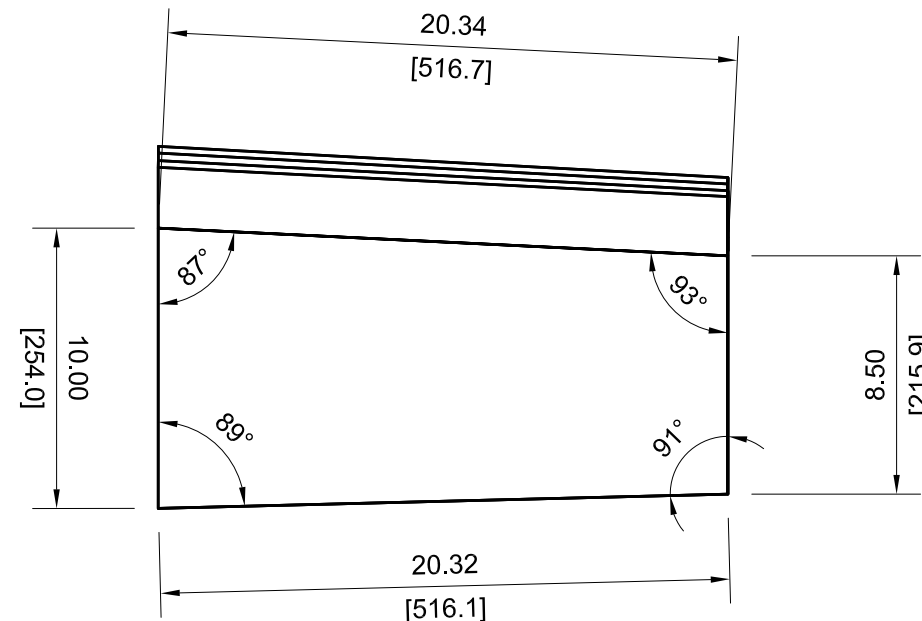

VIEW A6-138

NOTE: ALL VIEWS TAKEN AS TRUE VIEWS PARALLEL TO SURFACE OF PART

		DRAWING NUMBER			
		AES-D0002			
SIZE	SCALE	SHEET	OF	REVISION	
A3	NONE	138	167	F	

-341

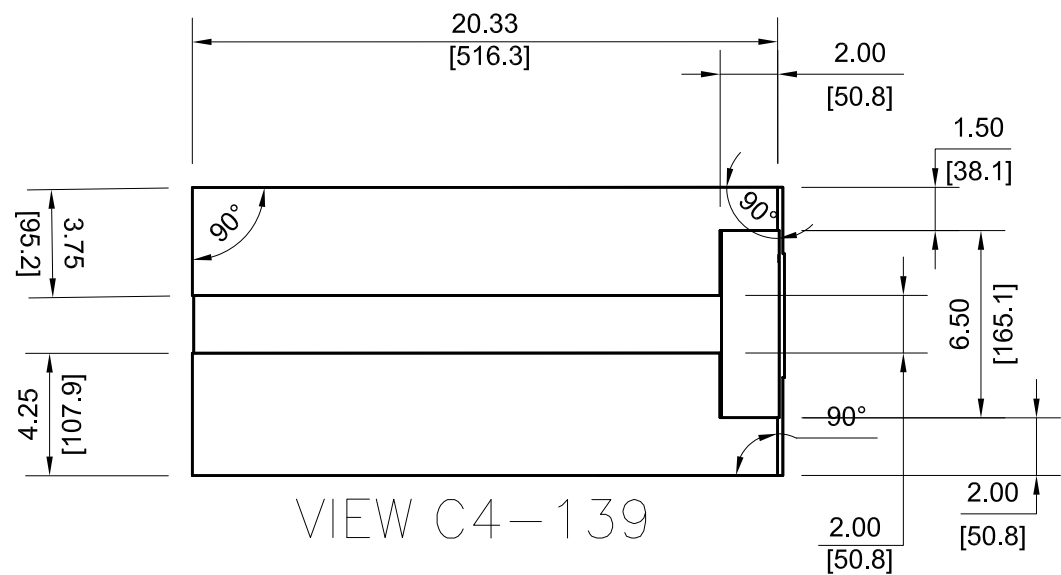

VIEW C4-139

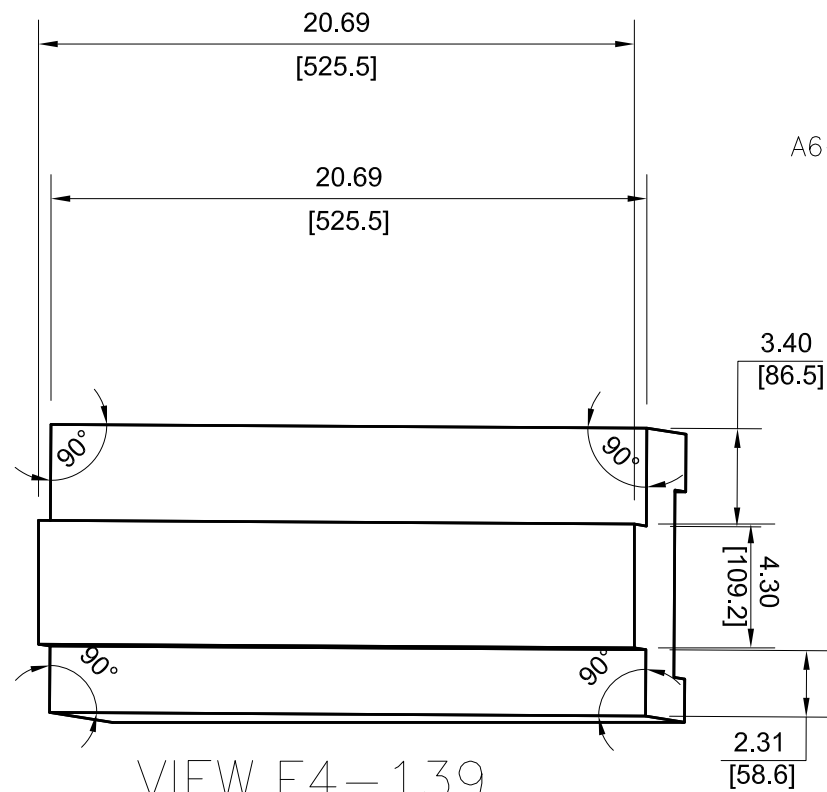

VIEW F4-139

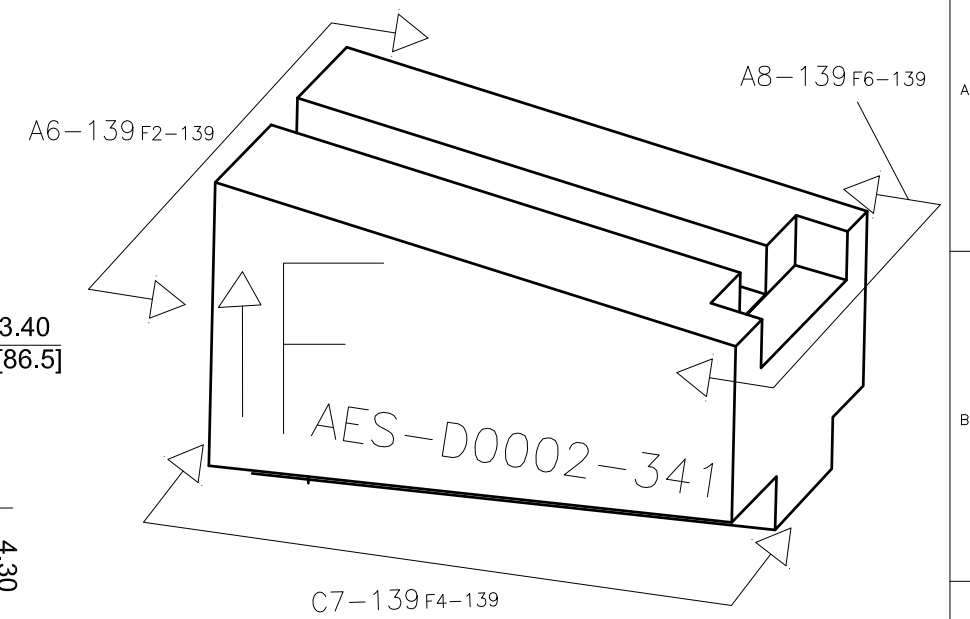

C4-139 B2-139

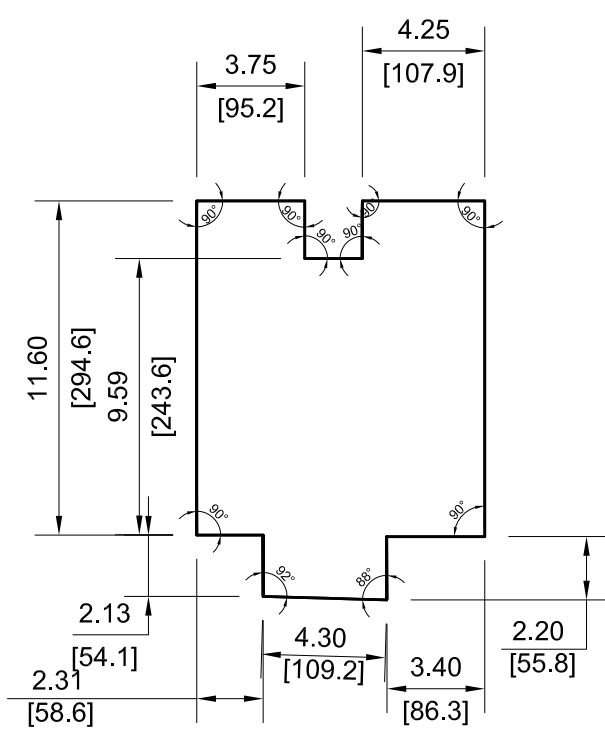

VIEW A6-139

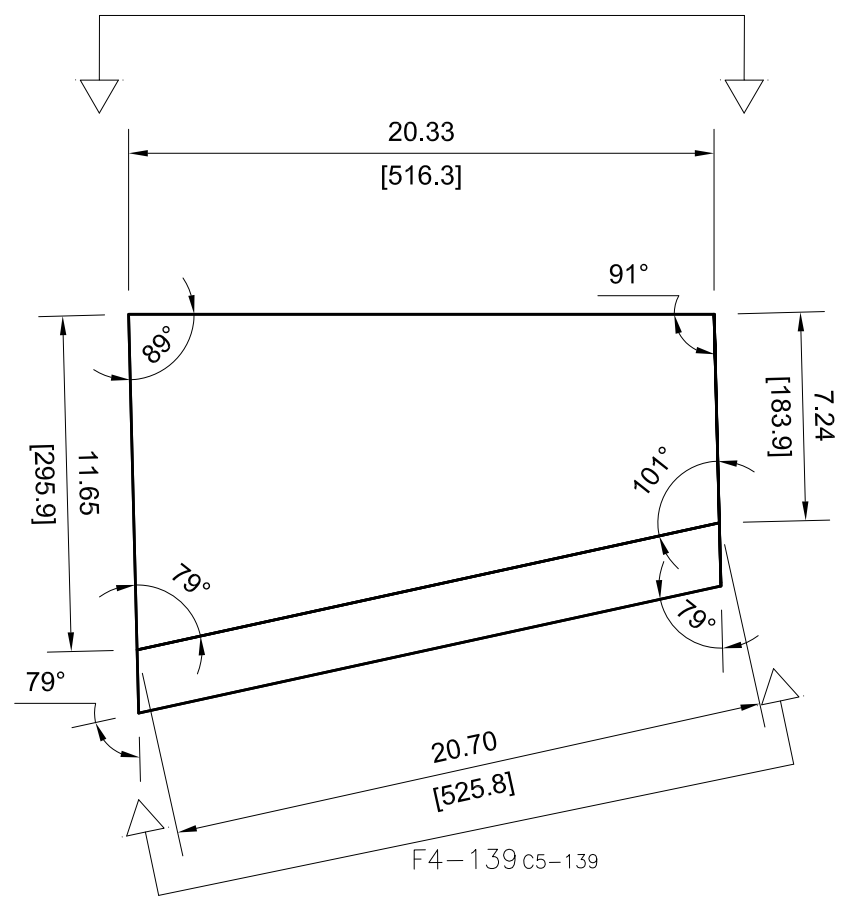

VIEW C7-139

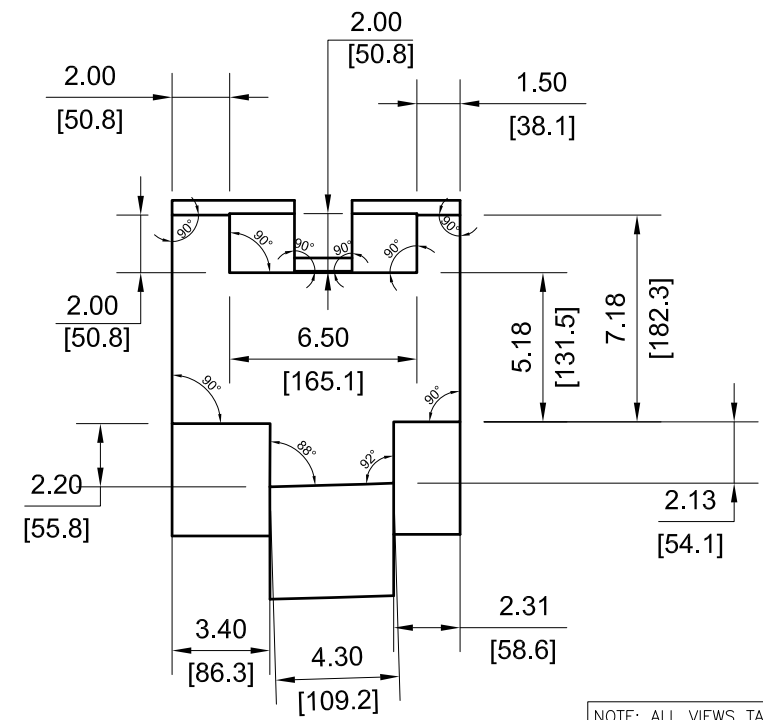

VIEW A8-139

NOTE: ALL VIEWS TAKEN AS TRUE VIEWS PARALLEL TO SURFACE OF PART

		DRAWING NUMBER			
		AES-D0002			
SIZE	SCALE	SHEET	OF	REVISION	
A3	NONE	139	167	F	

-343

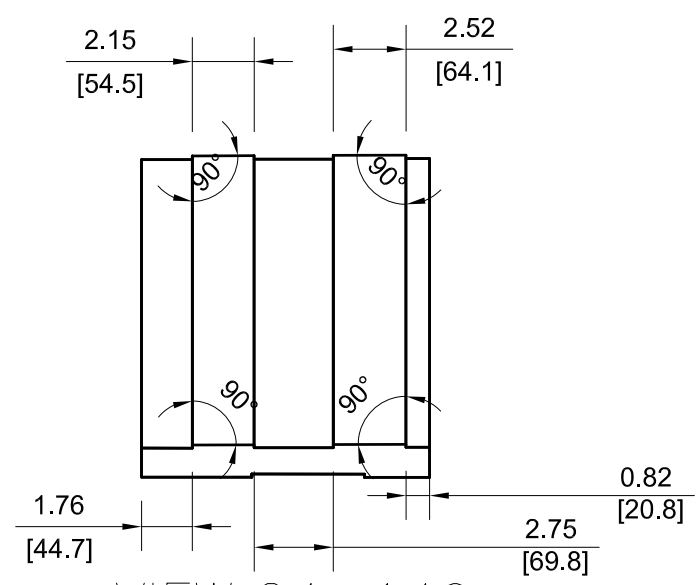

VIEW C4-140

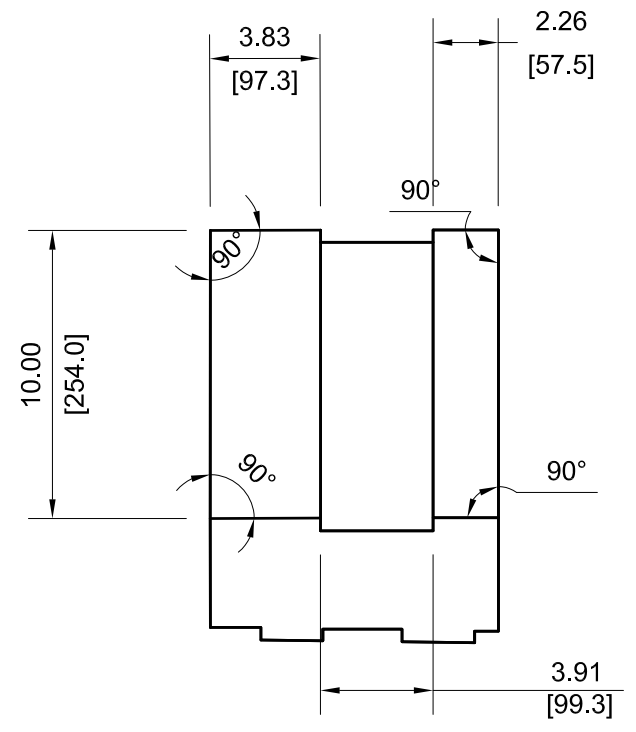

VIEW F4-140

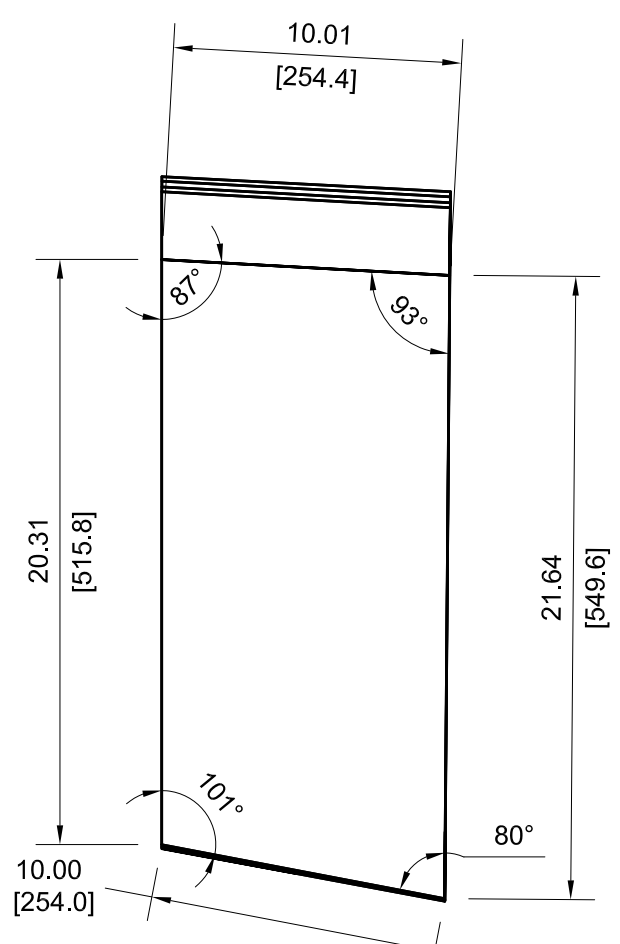
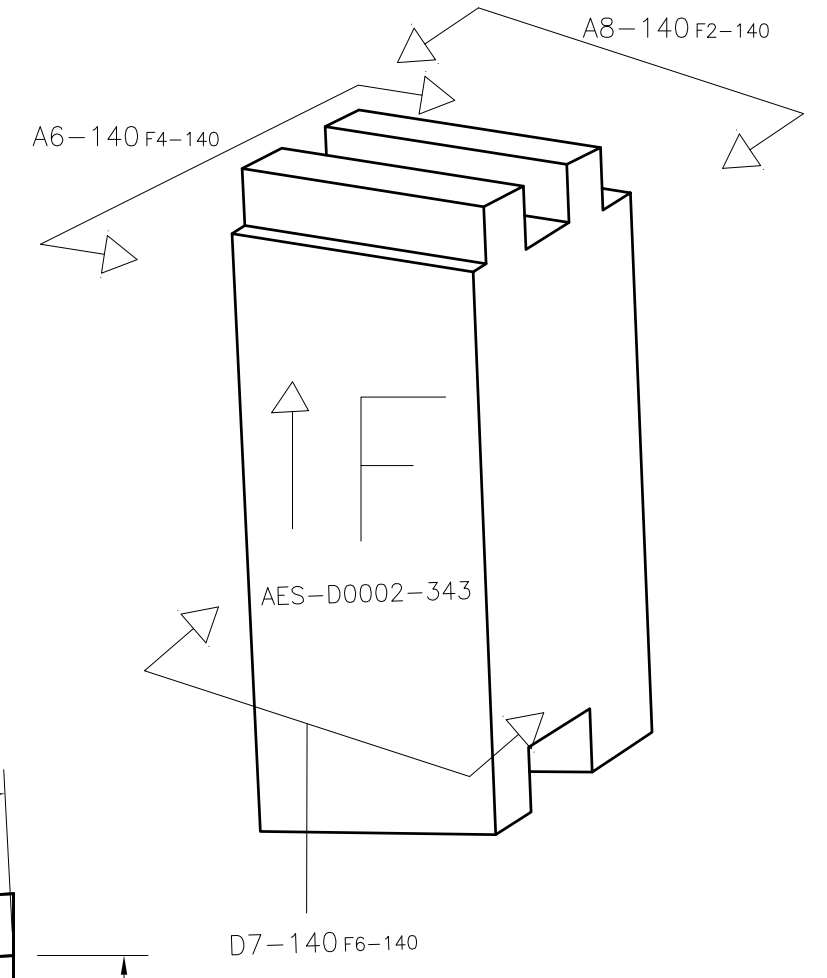

VIEW A8-140

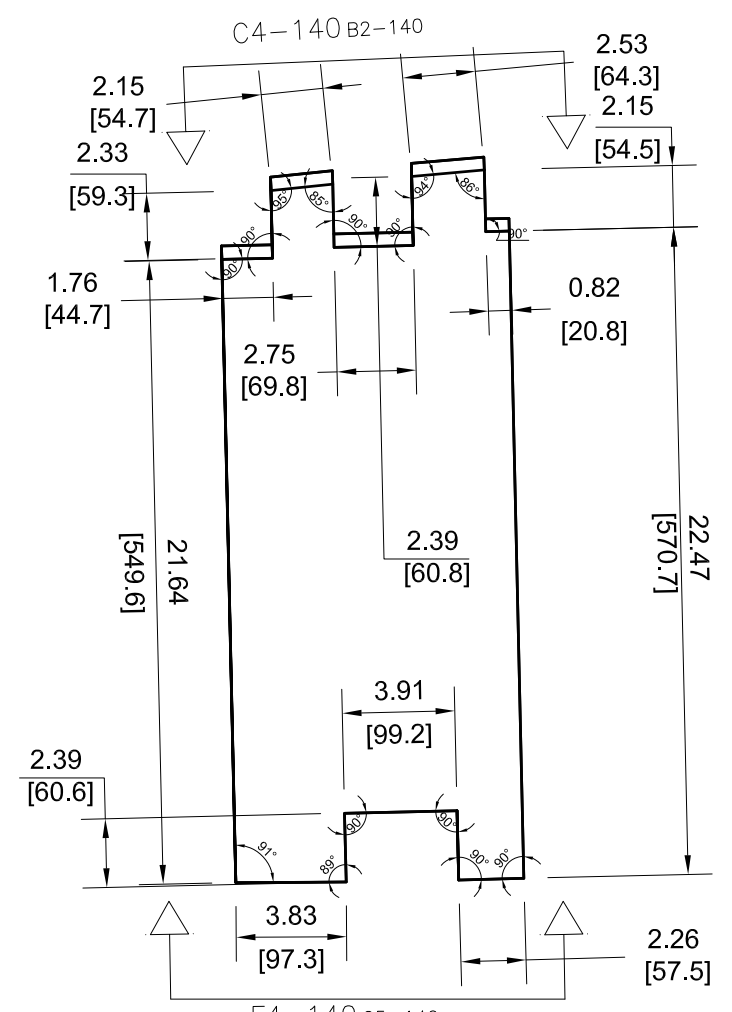

VIEW A6-140

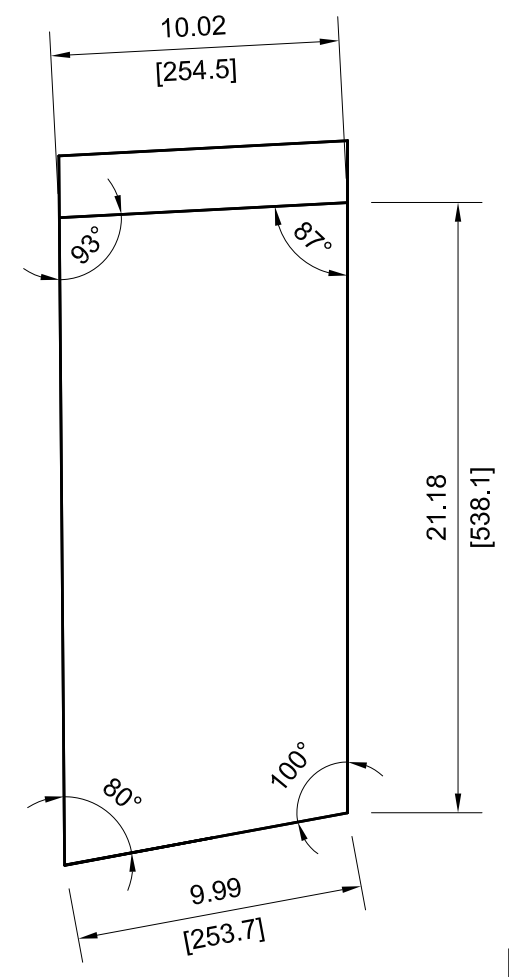

VIEW D7-140

NOTE: ALL VIEWS TAKEN AS TRUE VIEWS PARALLEL TO SURFACE OF PART

		DRAWING NUMBER			
		AES-D0002			
SIZE	SCALE	SHEET	OF	REVISION	
A3	NONE	140	167	F	

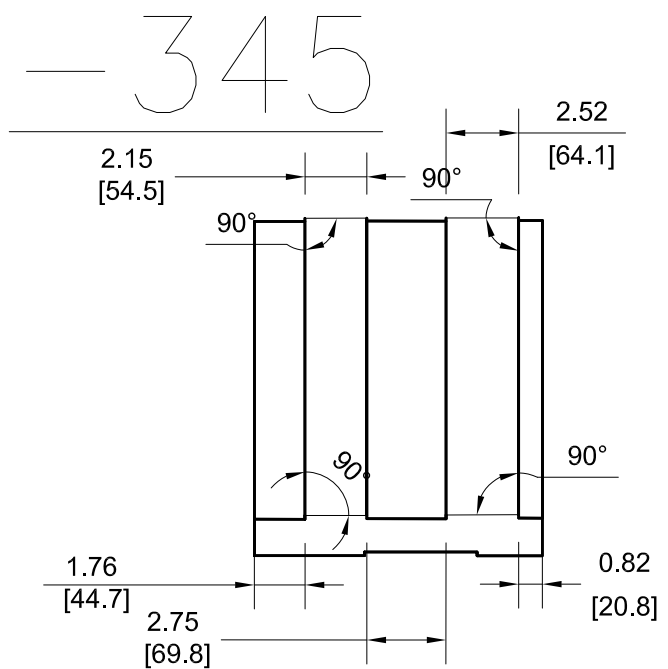

VIEW C4-141

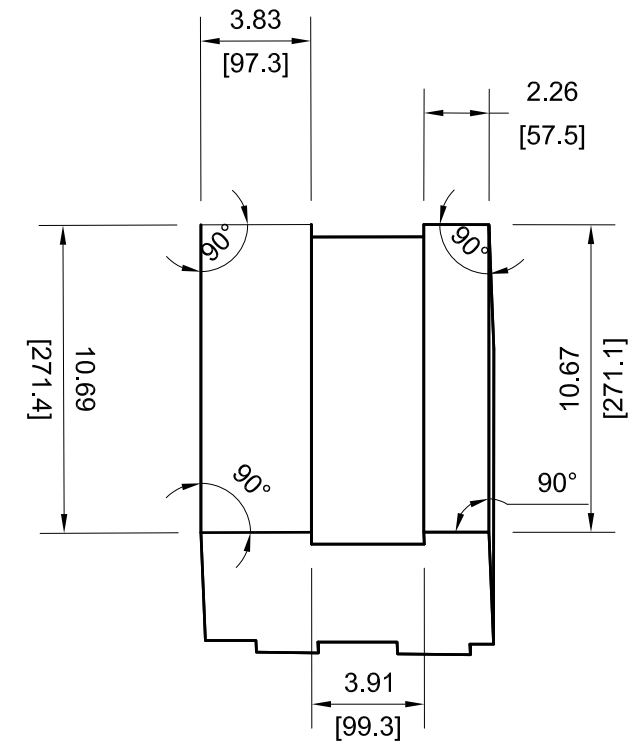

VIEW F4-141

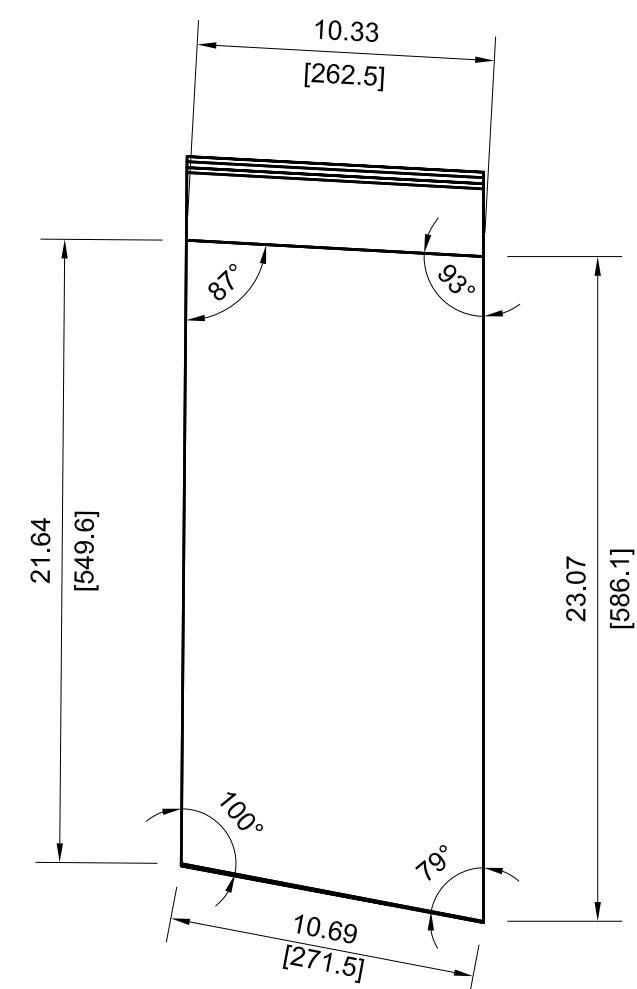
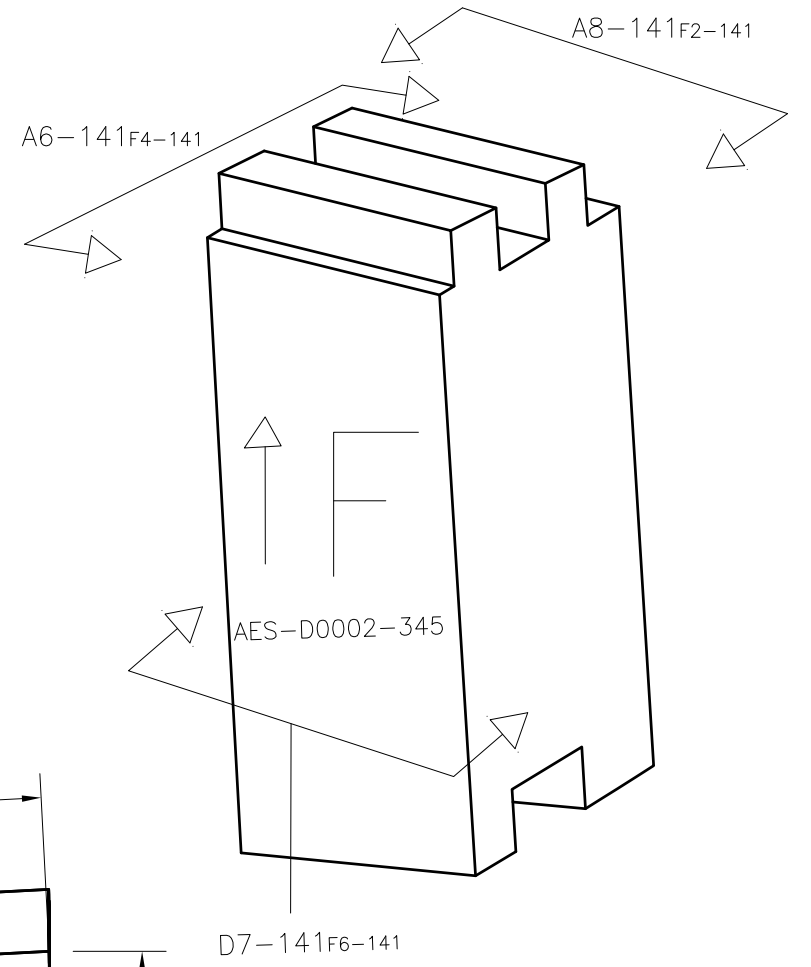

VIEW A8-141

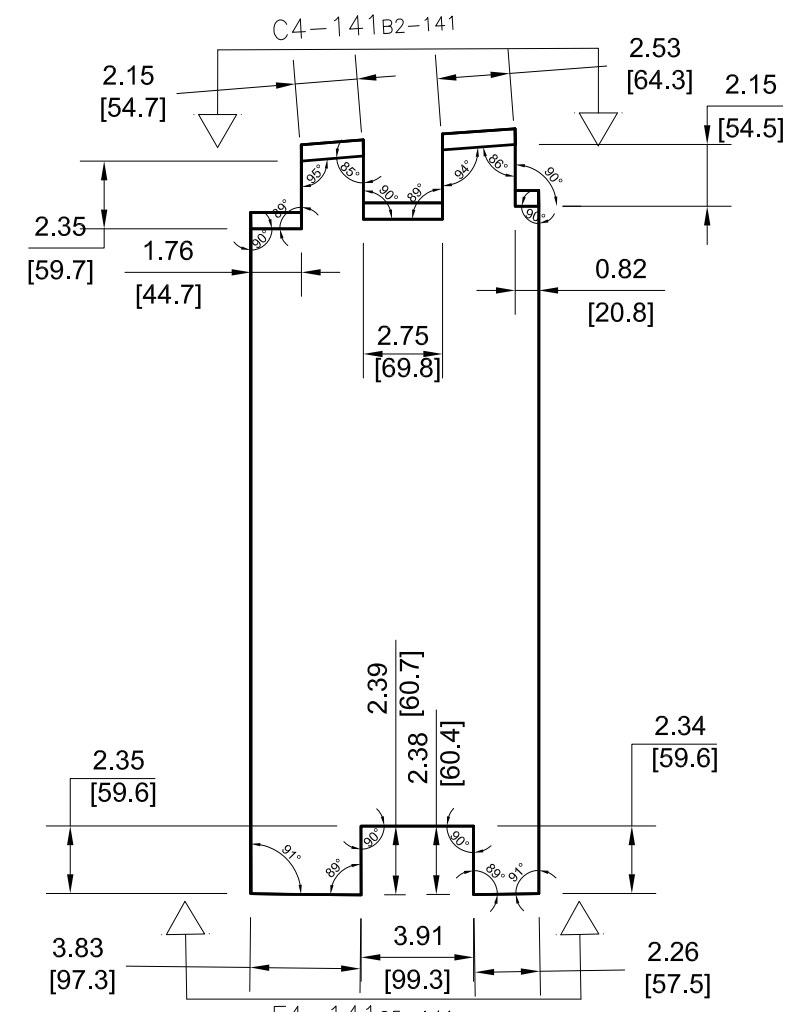

VIEW A6-141

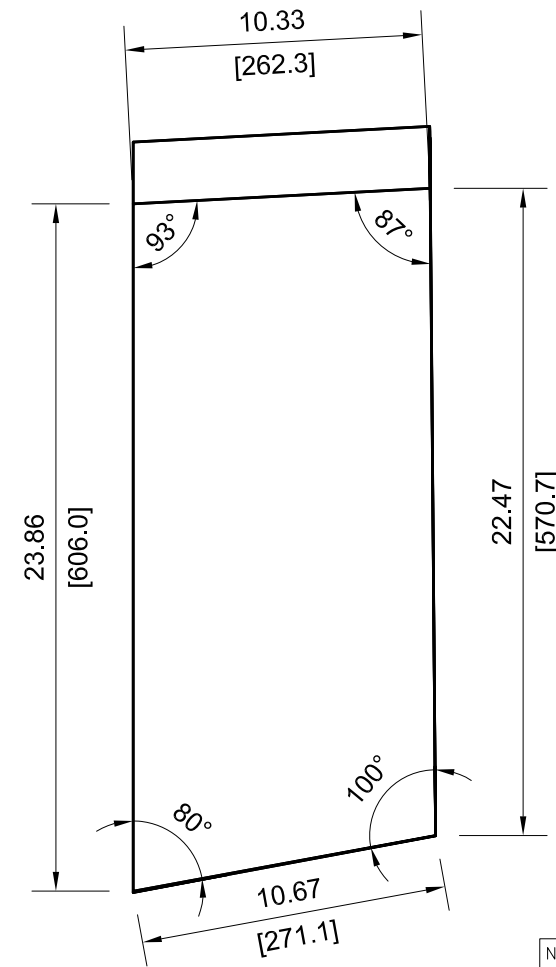

VIEW D7-141

NOTE: ALL VIEWS TAKEN AS TRUE VIEWS PARALLEL TO SURFACE OF PART

		DRAWING NUMBER			
		AES-D0002			
SIZE	SCALE	SHEET	OF	REVISION	
A3	NONE	141	167	F	

-347

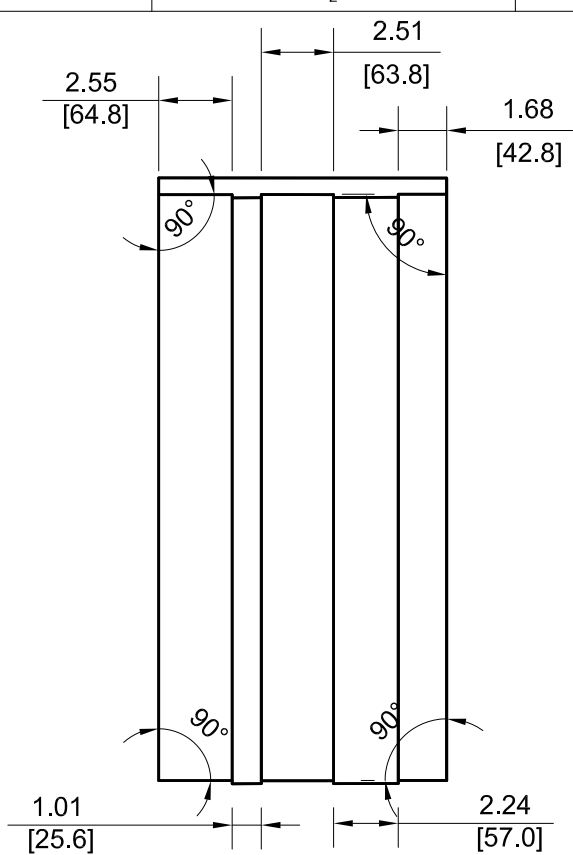

VIEW C4-142

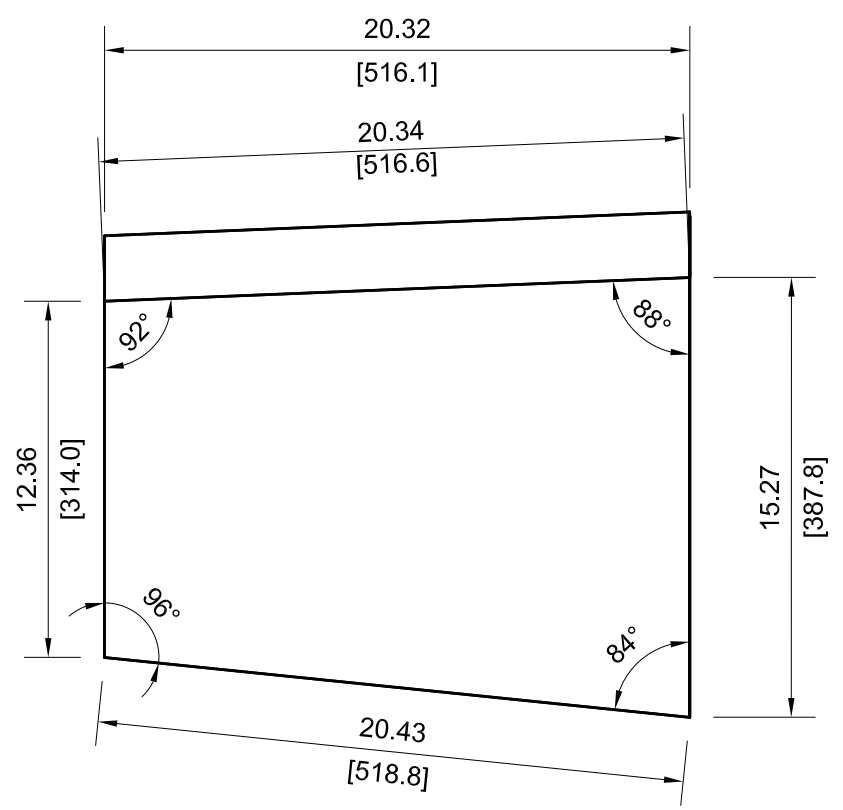
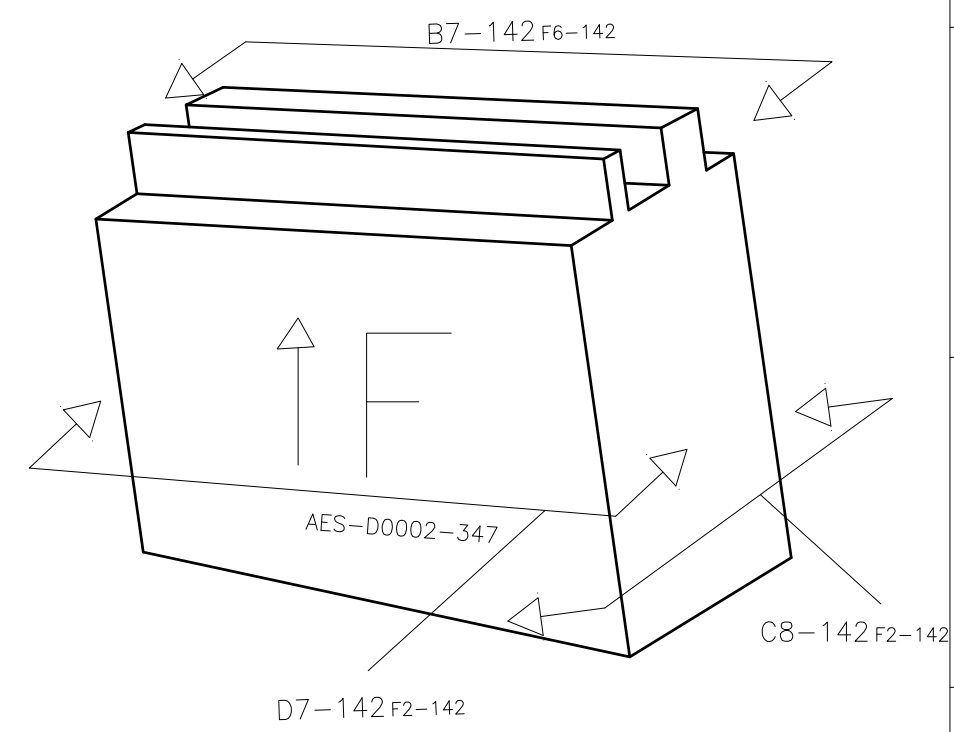

VIEW D7-142

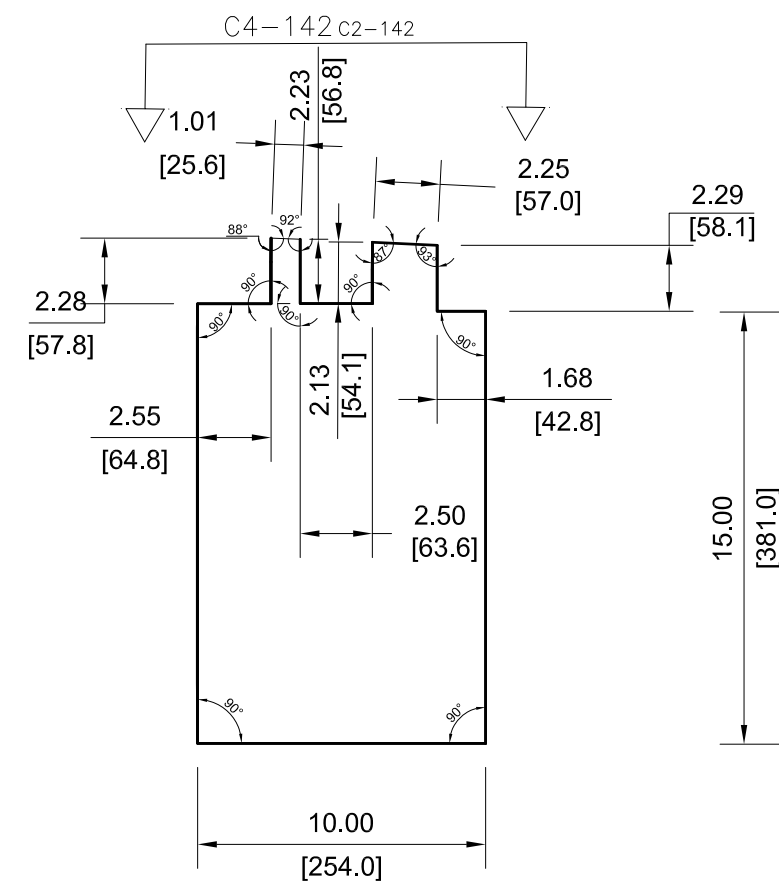

VIEW C8-142

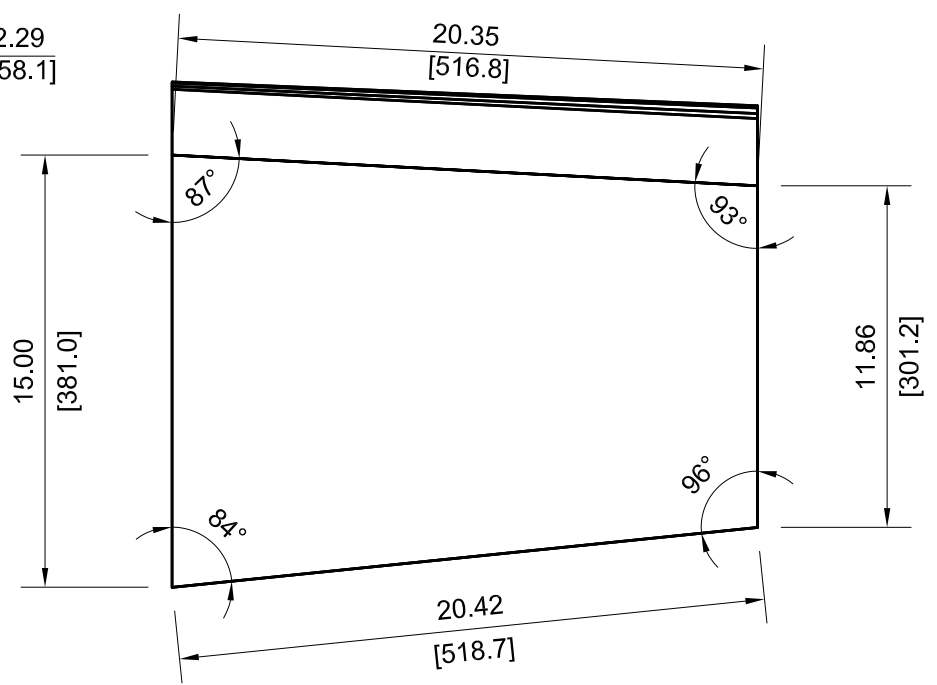

VIEW B7-142

NOTE: ALL VIEWS TAKEN AS TRUE VIEWS PARALLEL TO SURFACE OF PART

		DRAWING NUMBER			AES-D0002	
SIZE	SCALE	SHEET	OF	REVISION		
A3	NONE	142	167	F		

-349

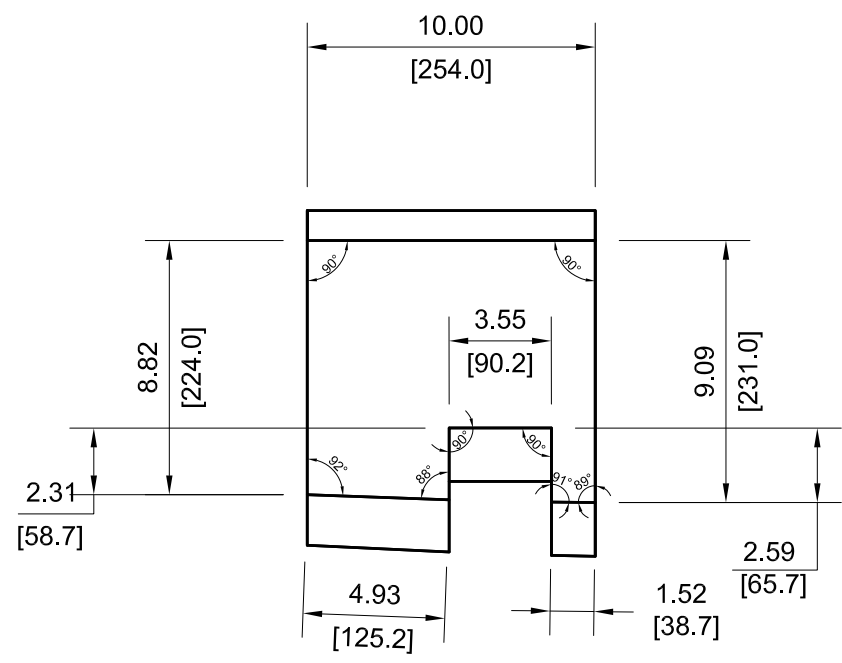

VIEW D8-143

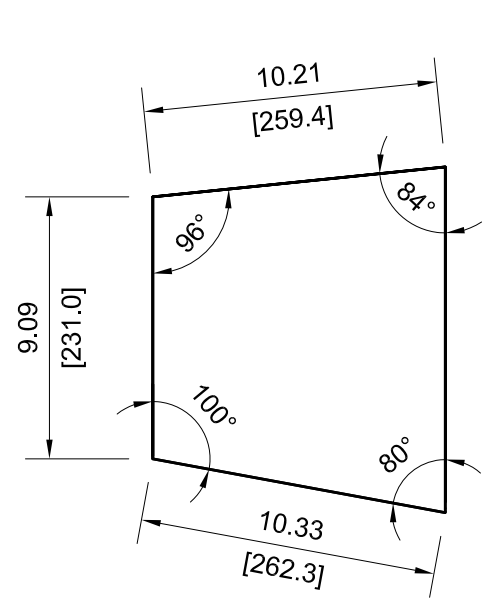
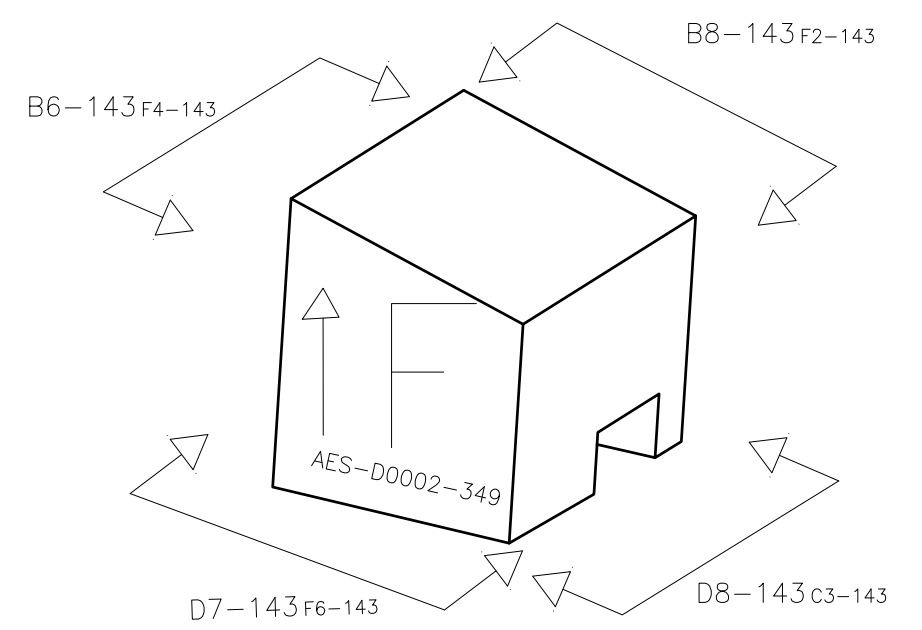

VIEW B8-143

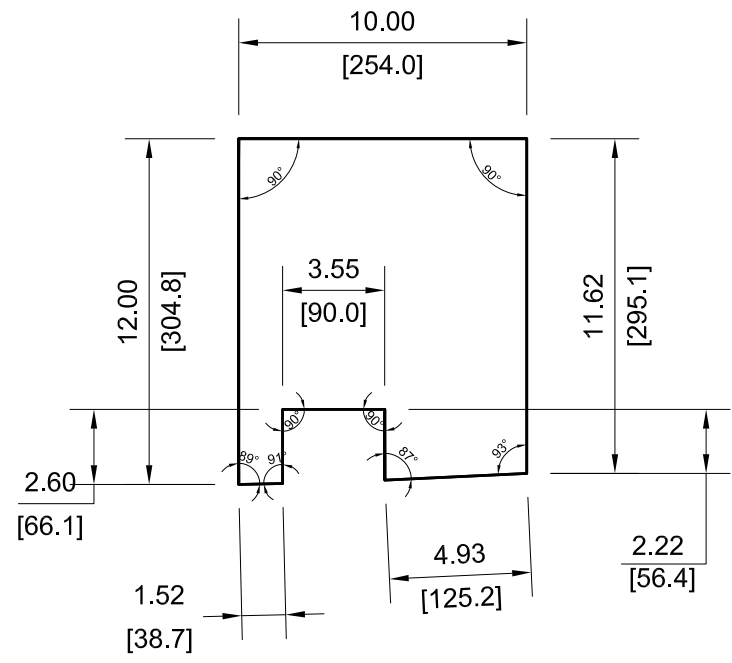

VIEW B6-143

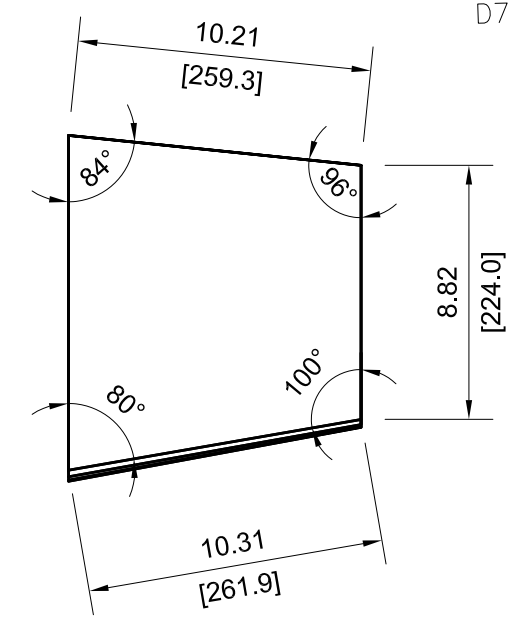

VIEW D7-143

NOTE: ALL VIEWS TAKEN AS TRUE VIEWS PARALLEL TO SURFACE OF PART

	DRAWING NUMBER			
	AES-D0002			
SIZE	SCALE	SHEET	OF	REVISION
A3	NONE	143	167	F

-351

VIEW D5-144

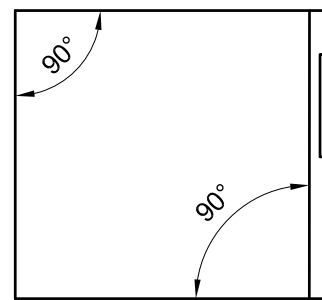

D5-144 C4-144

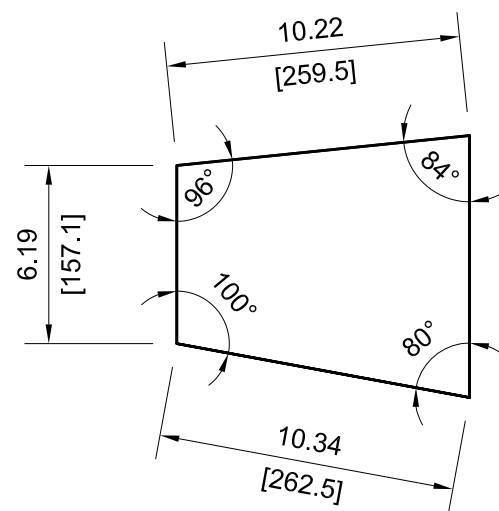
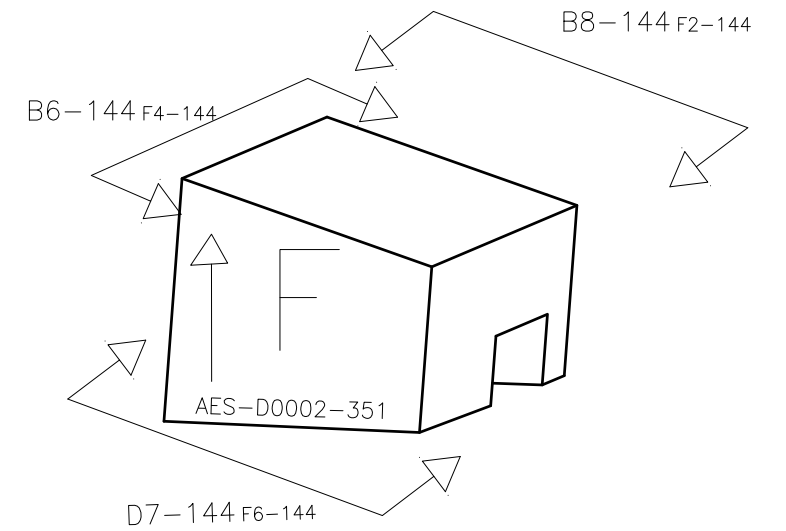

VIEW B8-144

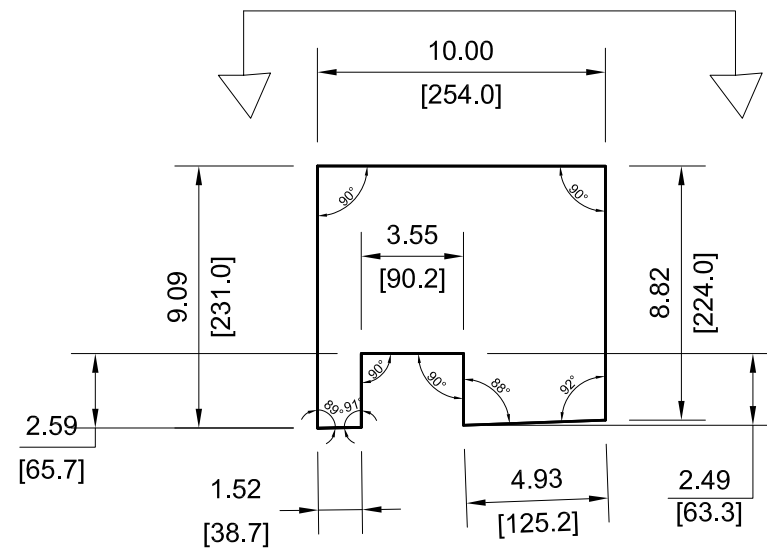

VIEW B6-144

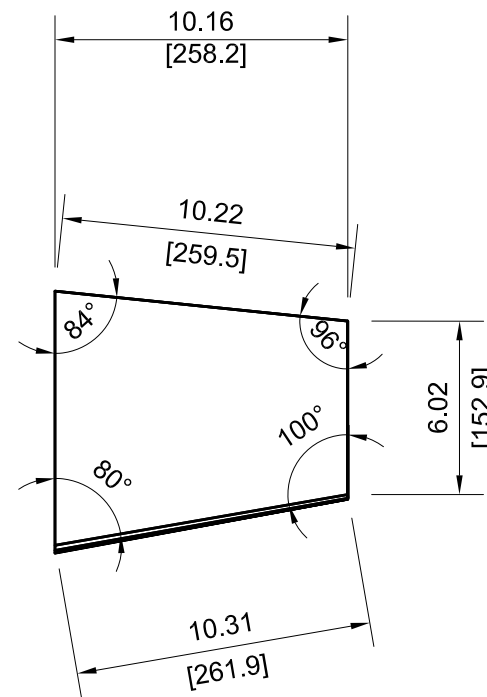

VIEW D7-144

NOTE: ALL VIEWS TAKEN AS TRUE VIEWS PARALLEL TO SURFACE OF PART

	DRAWING NUMBER				AES-D0002
	SIZE	SCALE	SHEET	OF	REVISION
A3	NONE	144	167	F	

-353

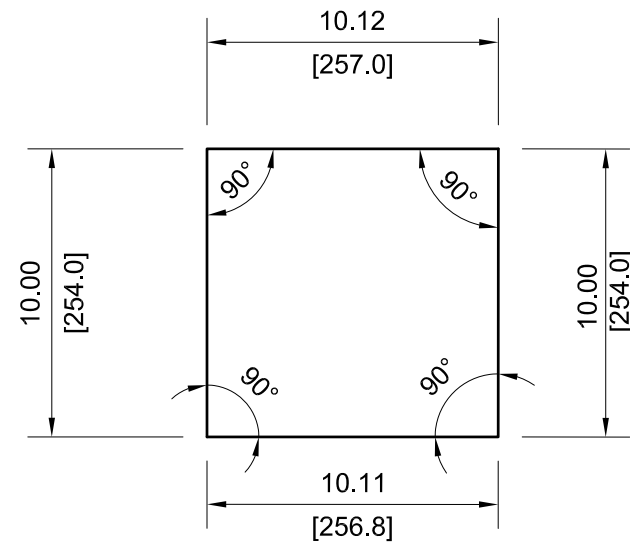

VIEW B7-145

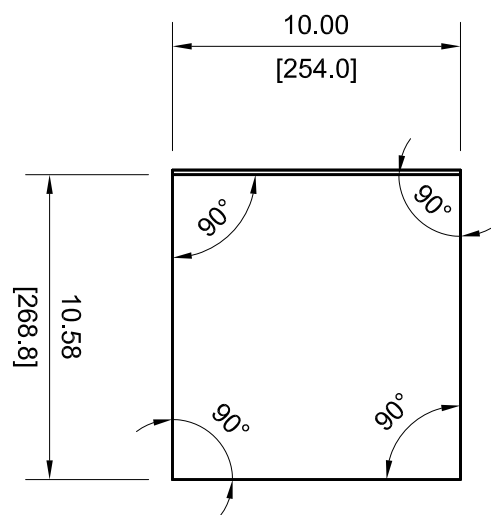
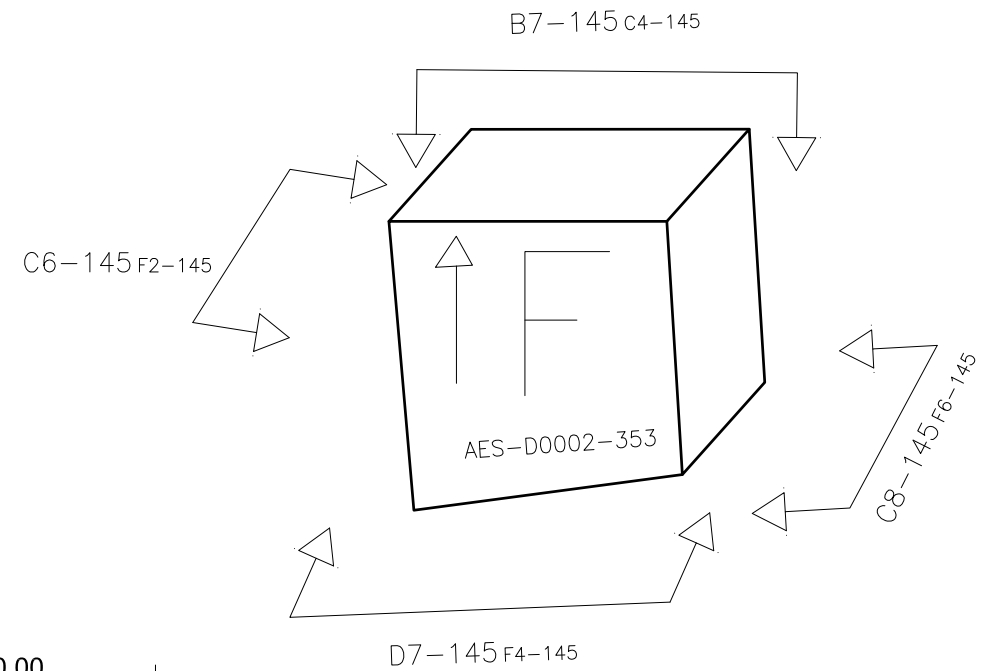

VIEW C6-145

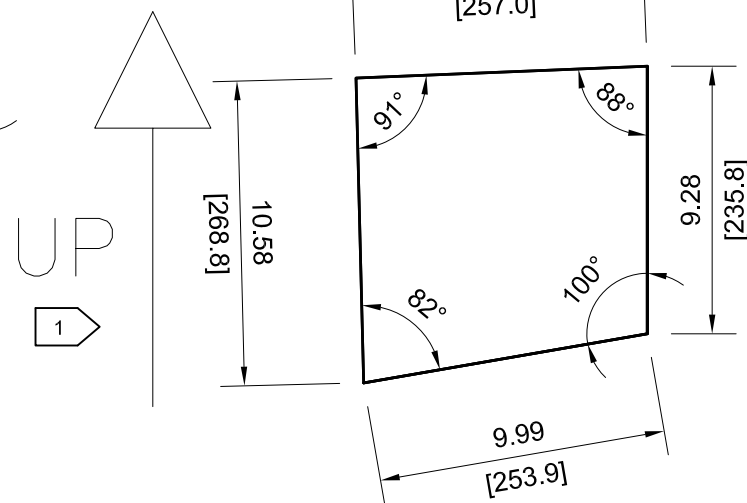

VIEW D7-145

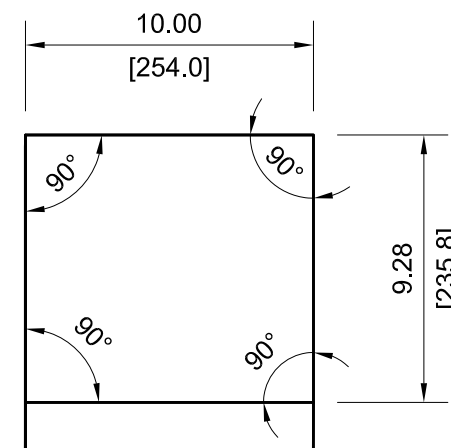

VIEW C8-145

NOTE: ALL VIEWS TAKEN AS TRUE VIEWS PARALLEL TO SURFACE OF PART

	DRAWING NUMBER				AES-D0002
	SIZE	SCALE	SHEET	OF	REVISION
A3	NONE	145	167	F	

- 355

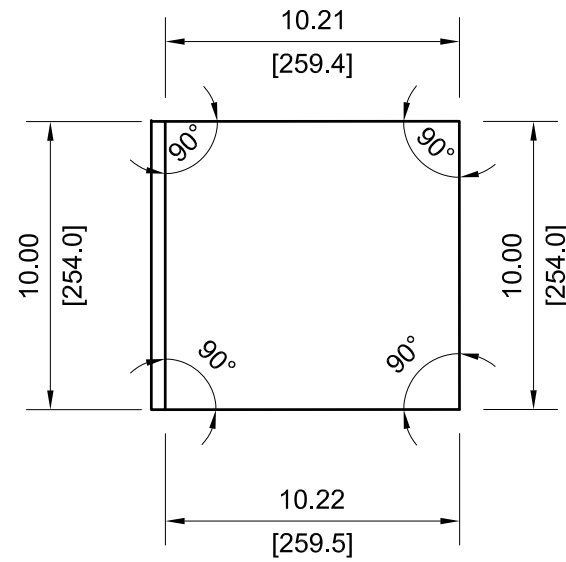

VIEW B7-146

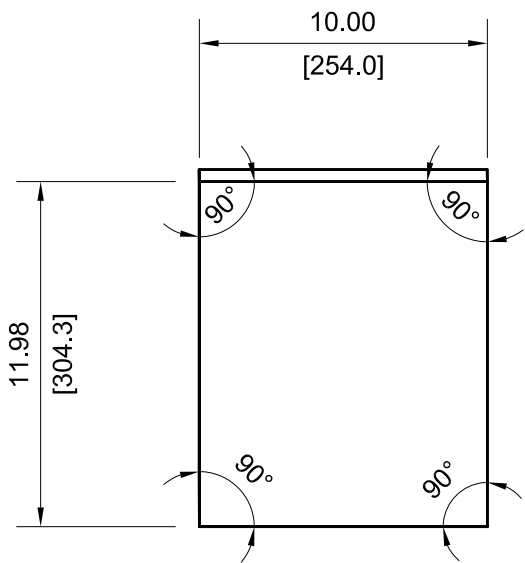
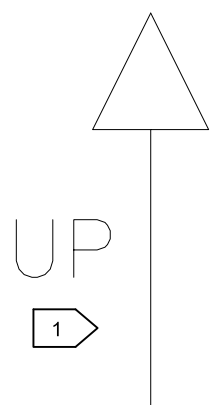
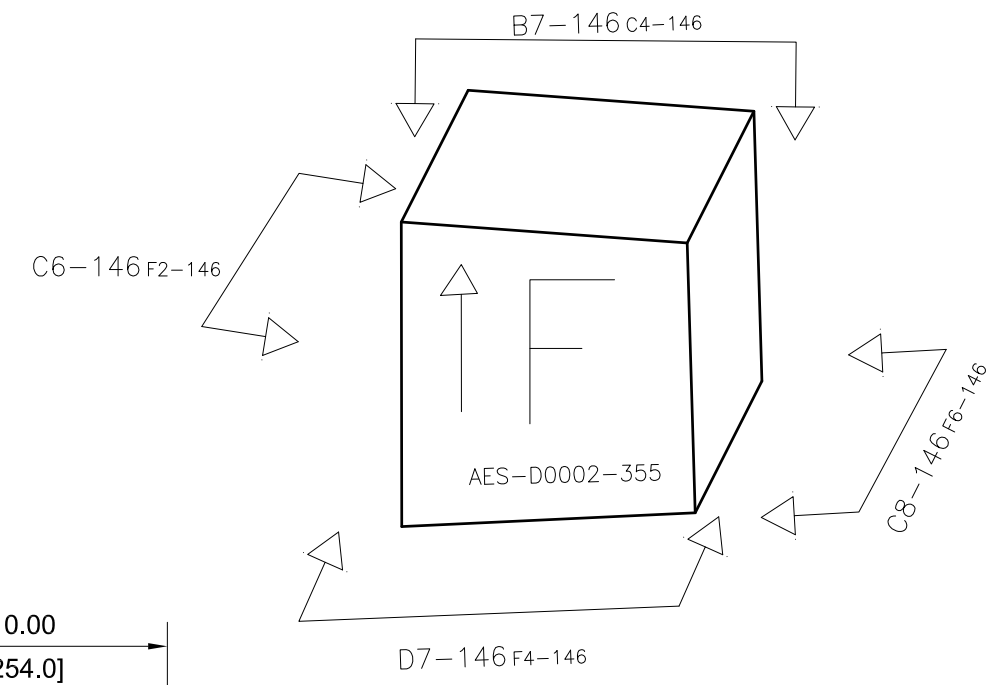

VIEW C6-146

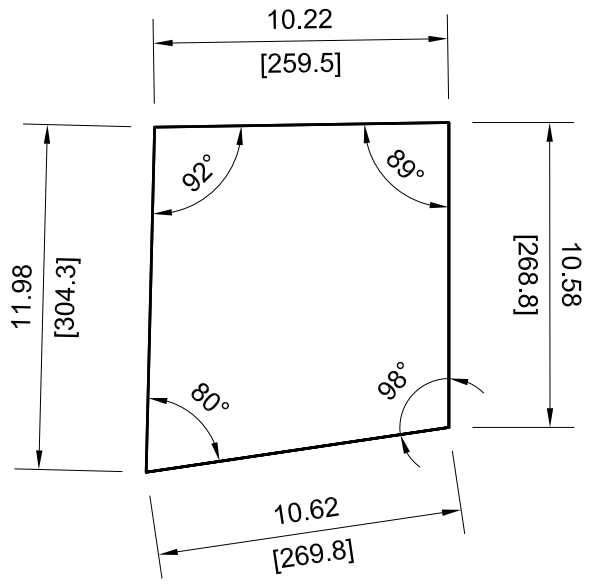

VIEW D7-146

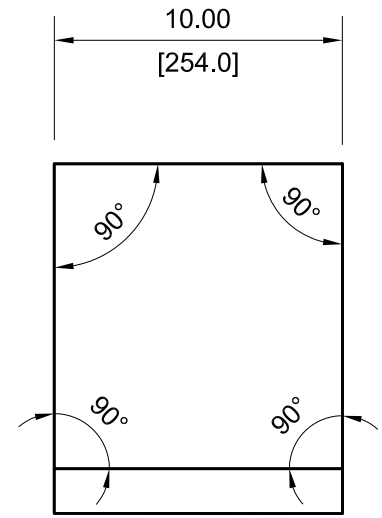

VIEW C8-146

NOTE: ALL VIEWS TAKEN AS TRUE VIEWS PARALLEL TO SURFACE OF PART

	DRAWING NUMBER				AES-D0002
	SIZE	SCALE	SHEET	OF	REVISION
A3	NONE	146	167	F	

-357

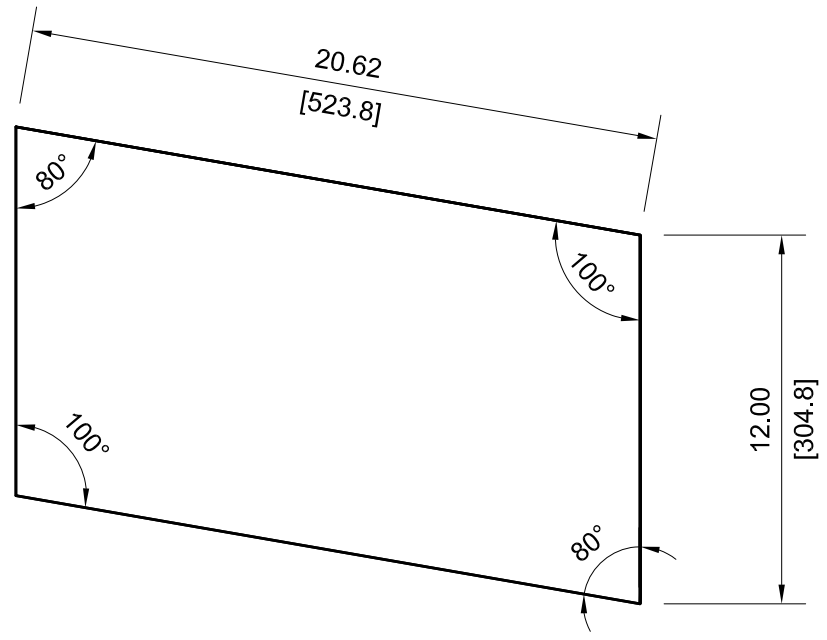
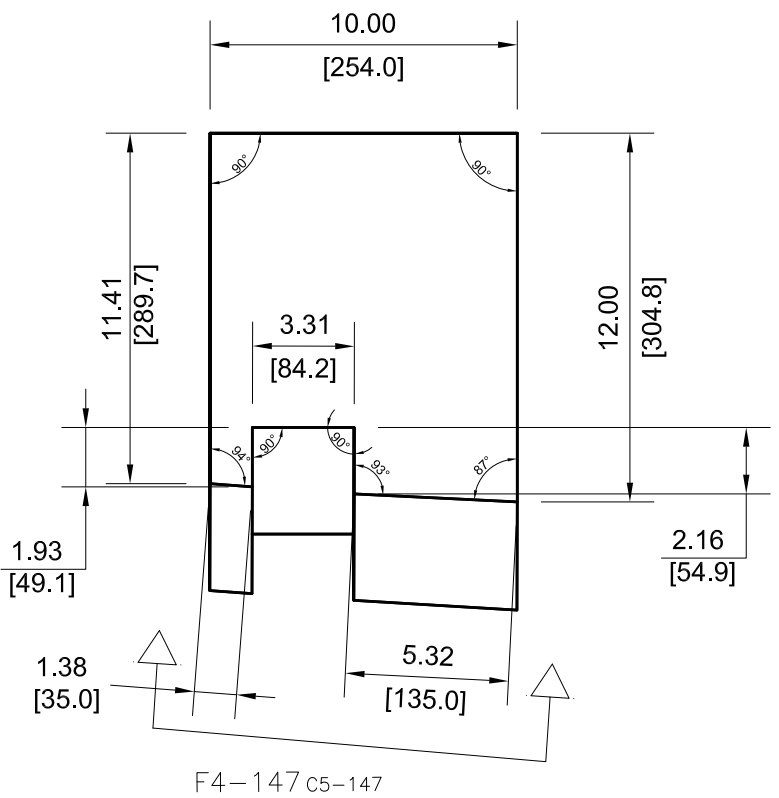
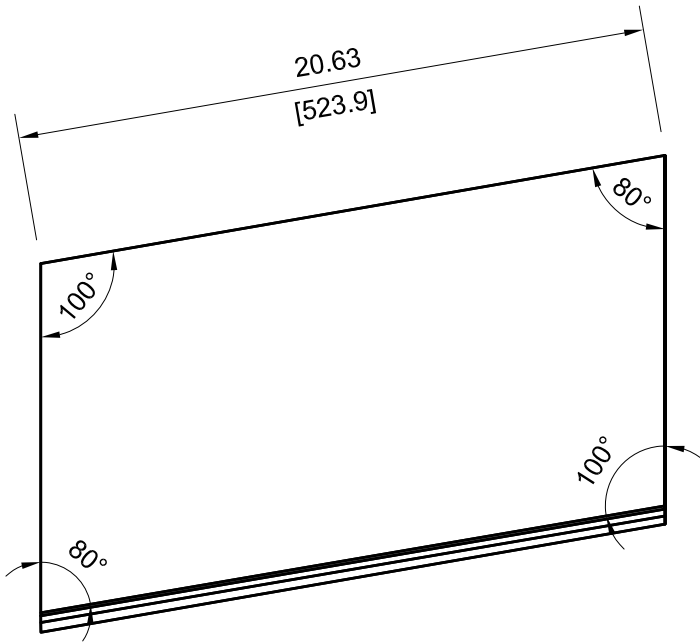
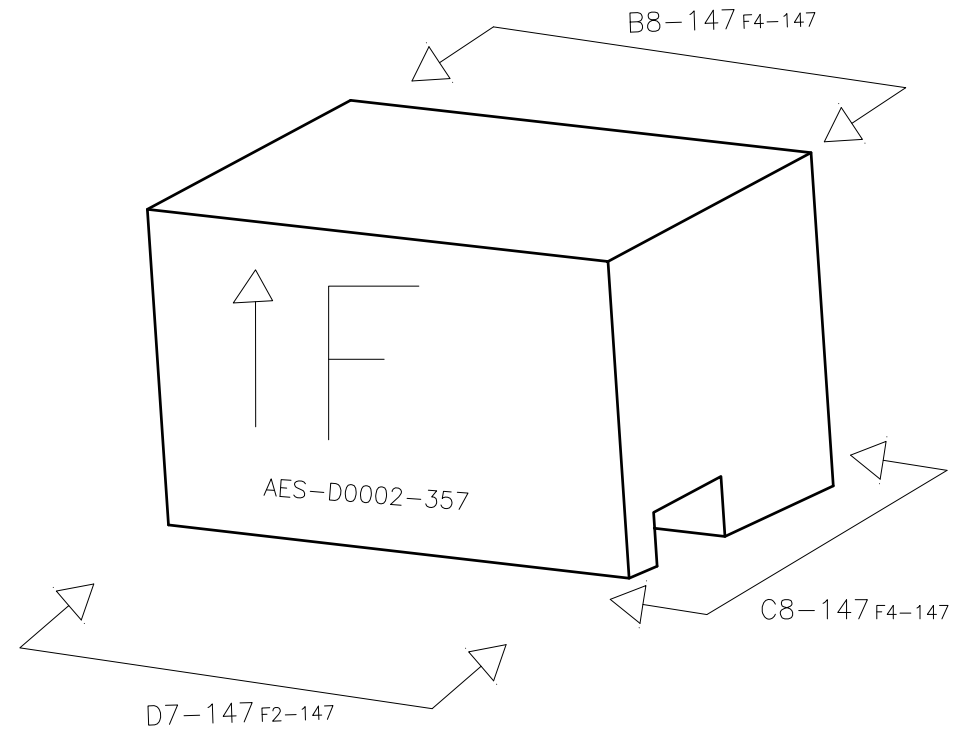
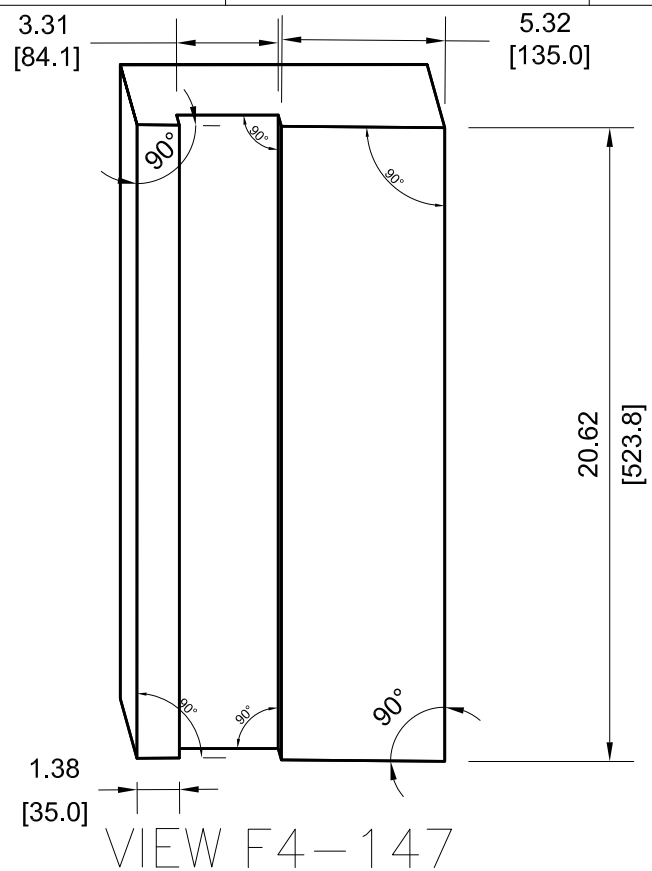

NOTE: ALL VIEWS TAKEN AS TRUE VIEWS PARALLEL TO SURFACE OF PART



DRAWING NUMBER				
AES-D0002				
SIZE	SCALE	SHEET	OF	REVISION
A3	NONE	147	167	F

- 359

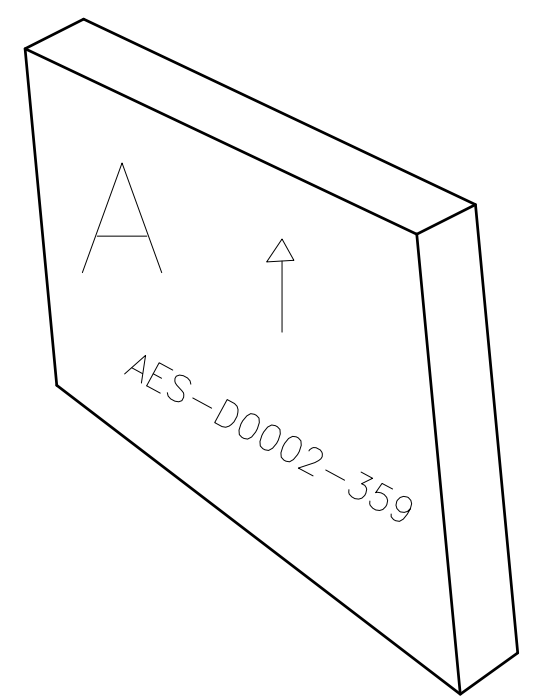
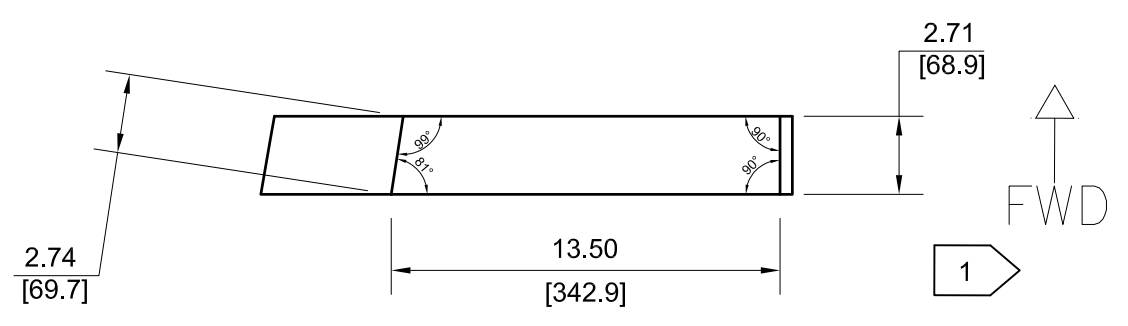
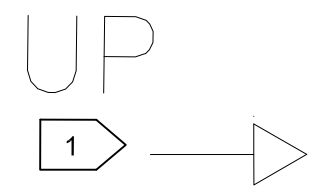
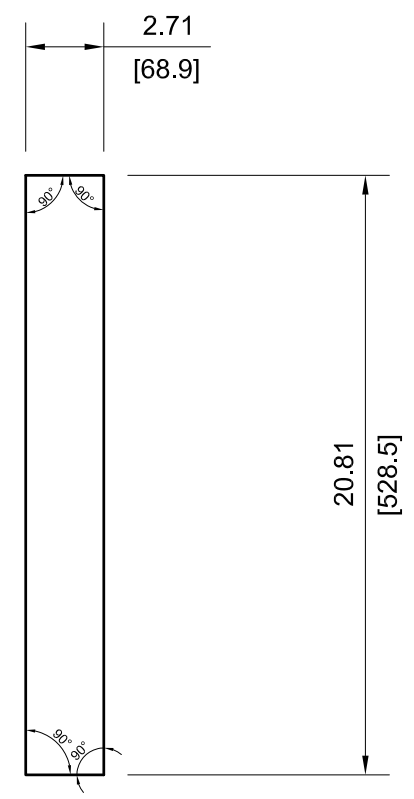
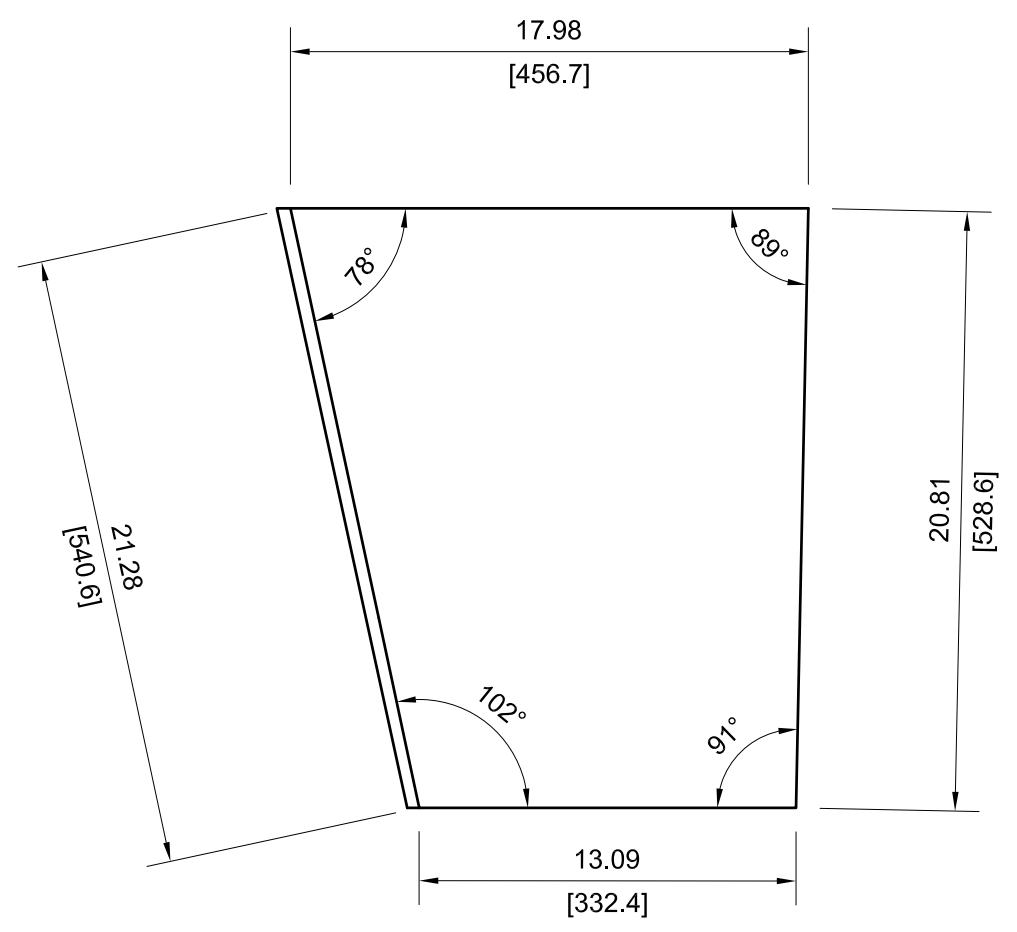
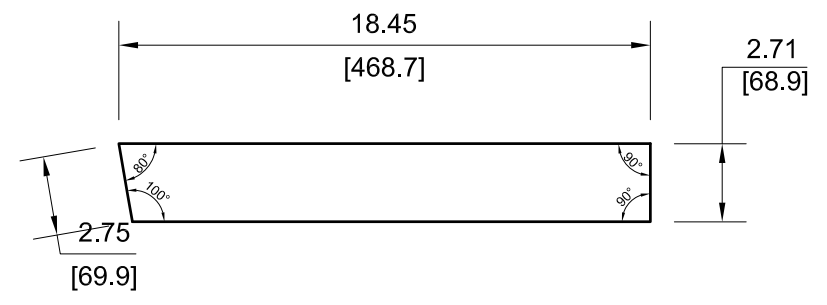

NOTE: ALL VIEWS TAKEN AS TRUE VIEWS PARALLEL TO SURFACE OF PART

	DRAWING NUMBER				AES-D0002	
	SIZE	SCALE	SHEET	OF	REVISION	
A3	NONE	148	167	F		

-361

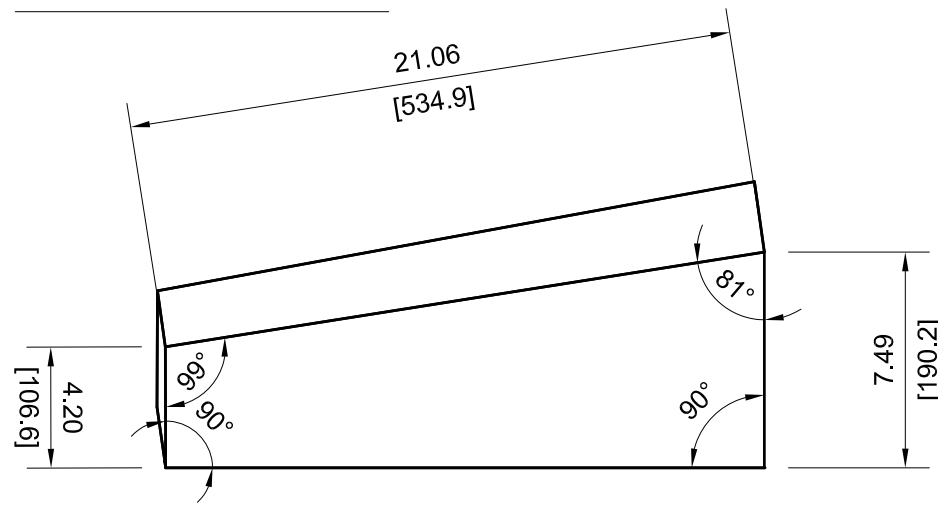

VIEW C4-149

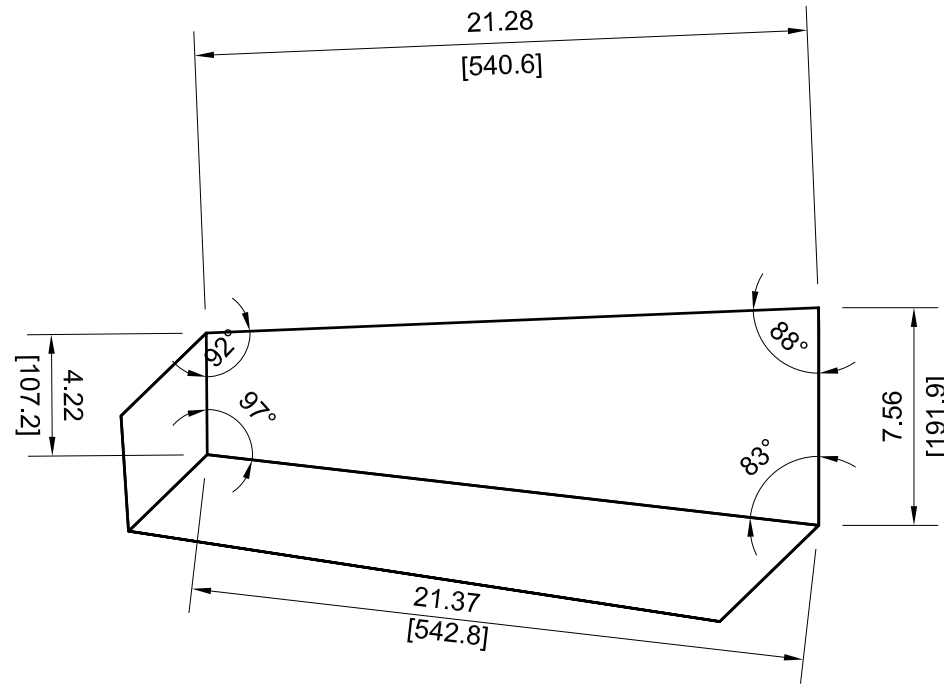

VIEW F4-149

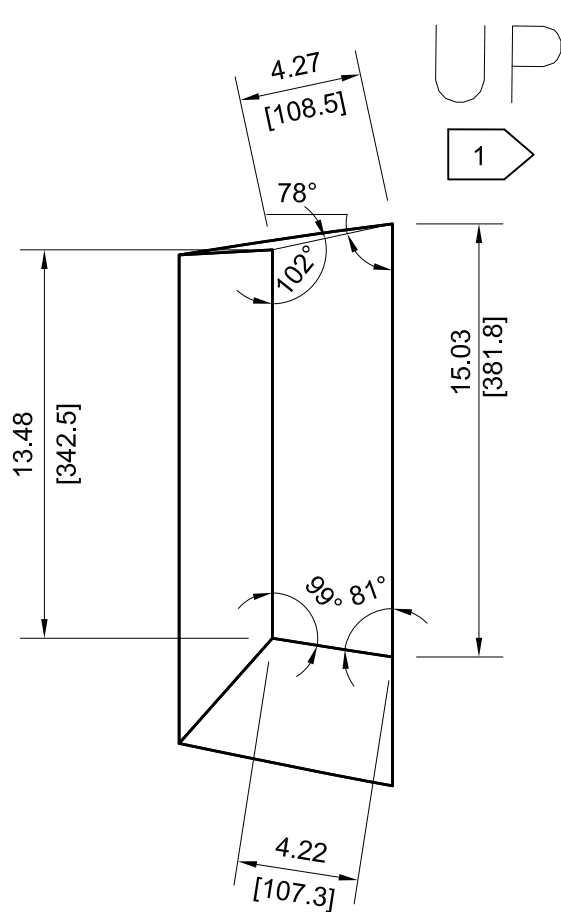
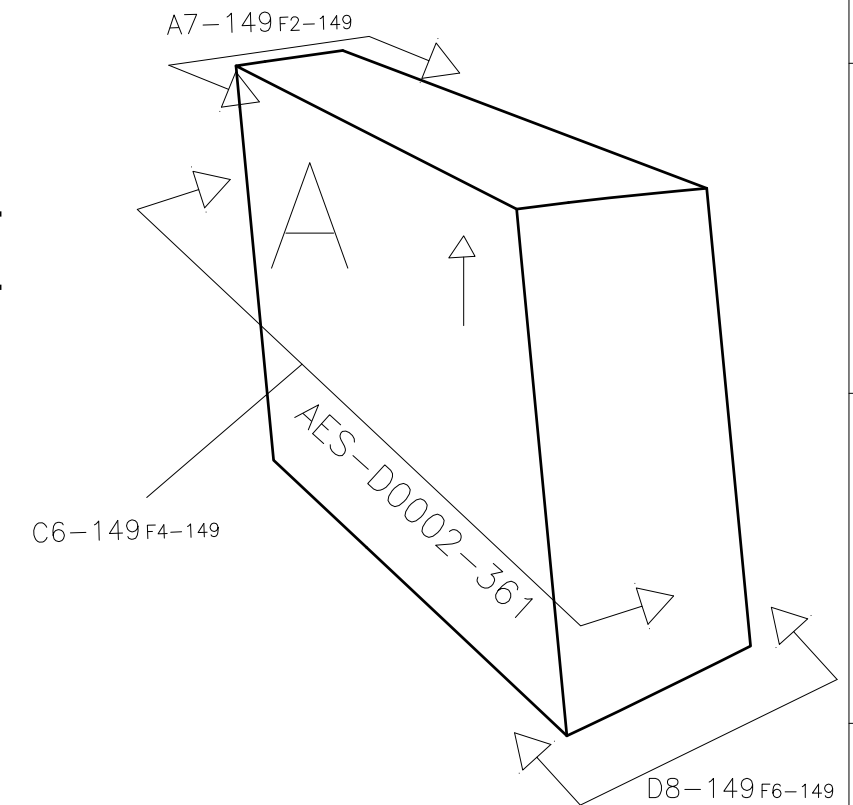

VIEW A7-149

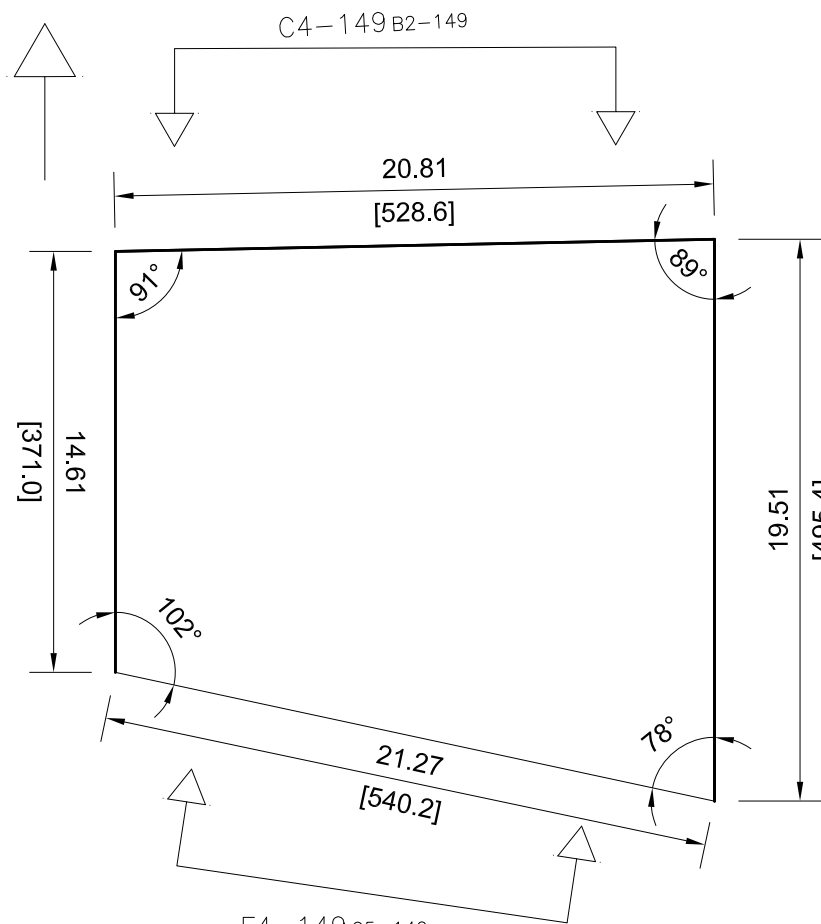

VIEW C6-149

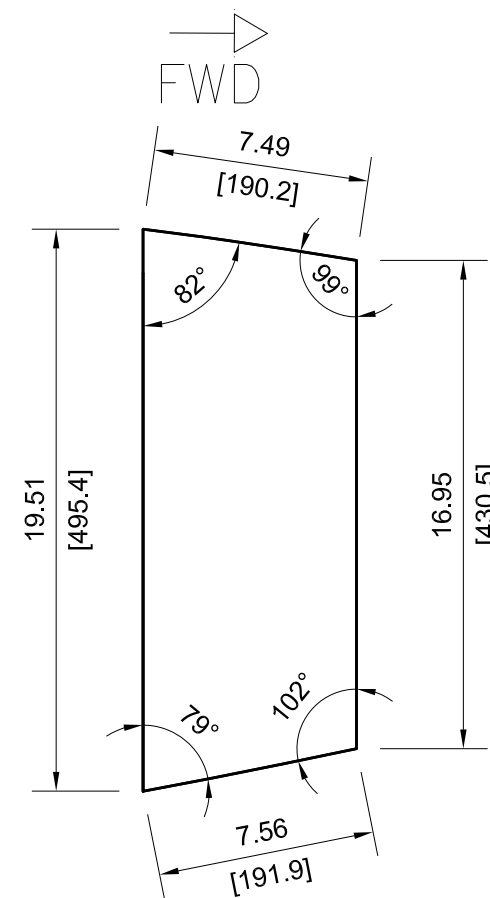

VIEW D8-149

NOTE: ALL VIEWS TAKEN AS TRUE VIEWS PARALLEL TO SURFACE OF PART

	DRAWING NUMBER				AES-D0002
	SIZE	SCALE	SHEET	OF	REVISION
A3	NONE	149	167	F	

- 363

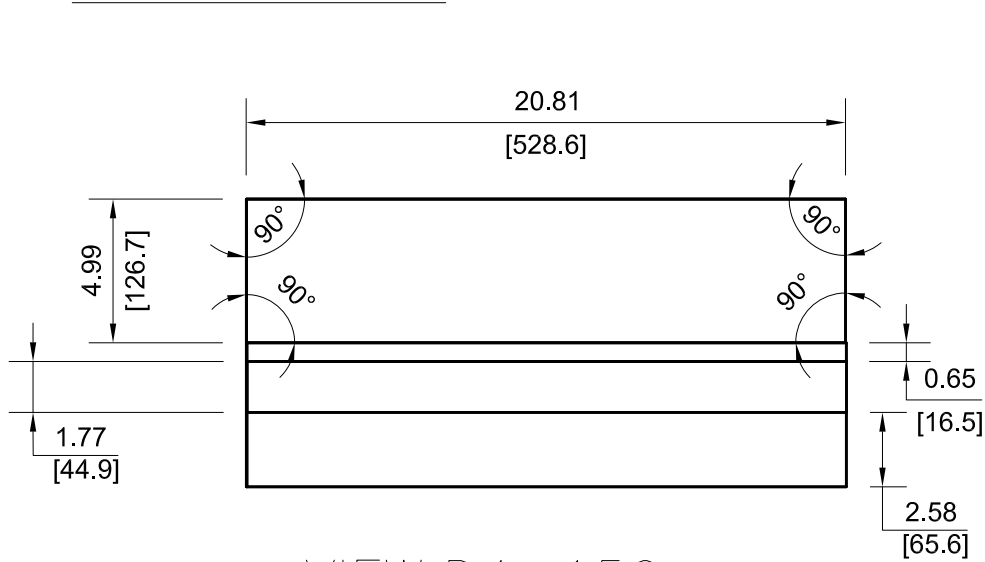

VIEW D4-150

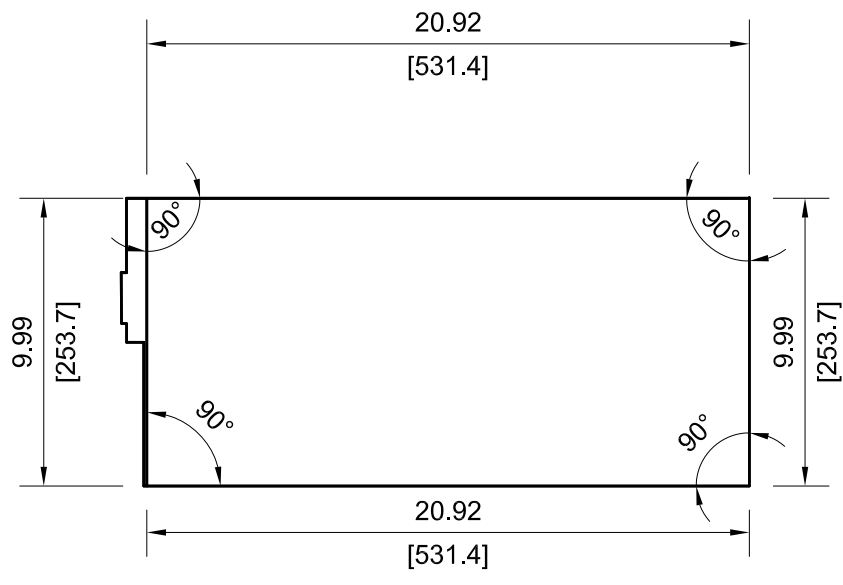

VIEW F4-150

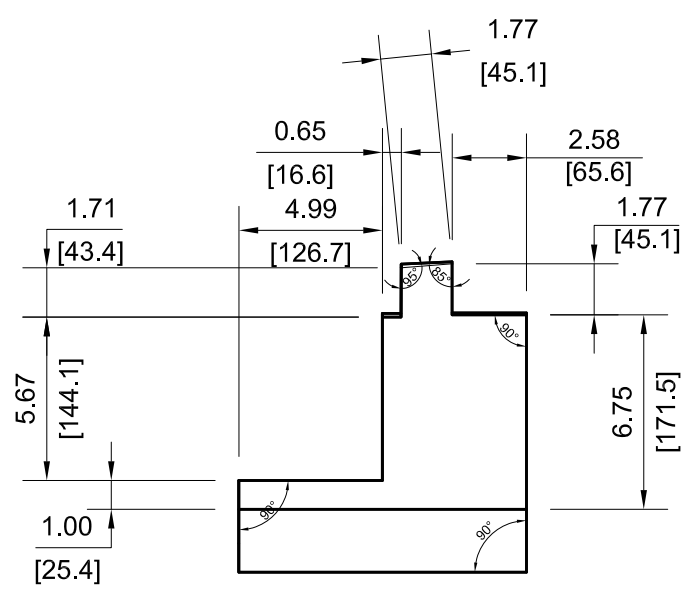
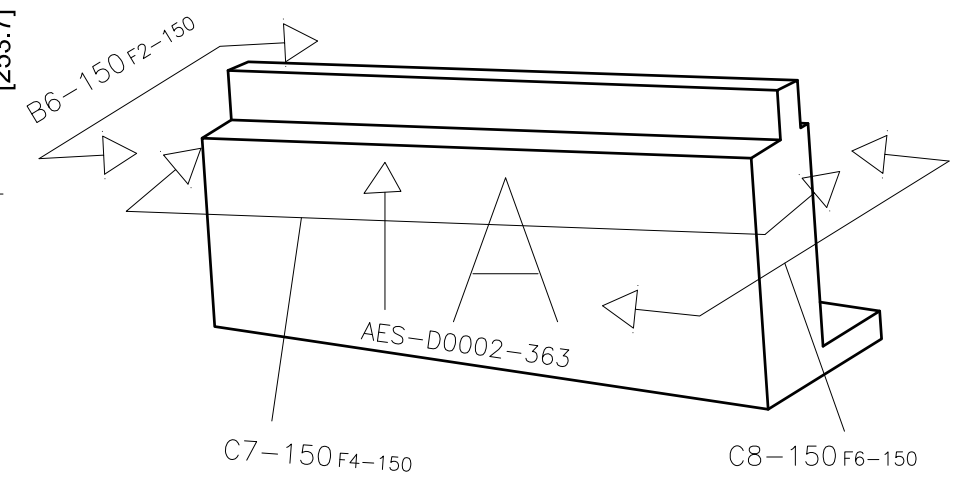

VIEW B6-150

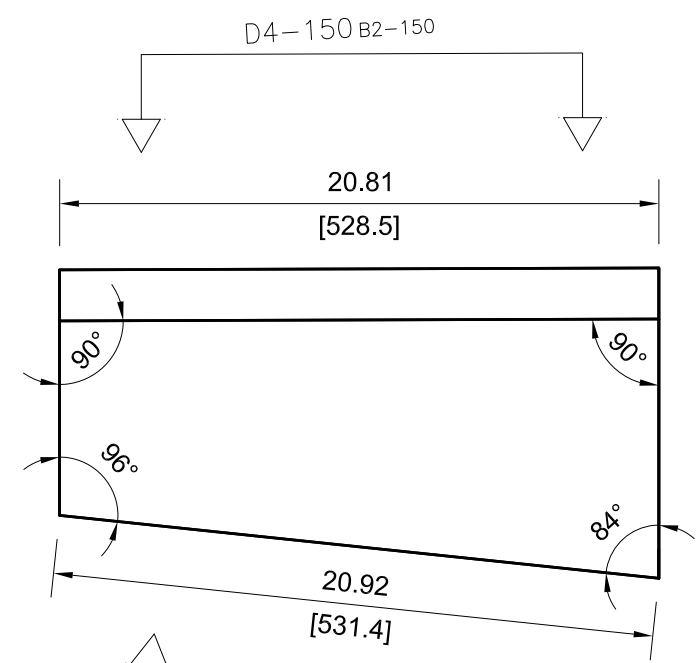

VIEW C7-150

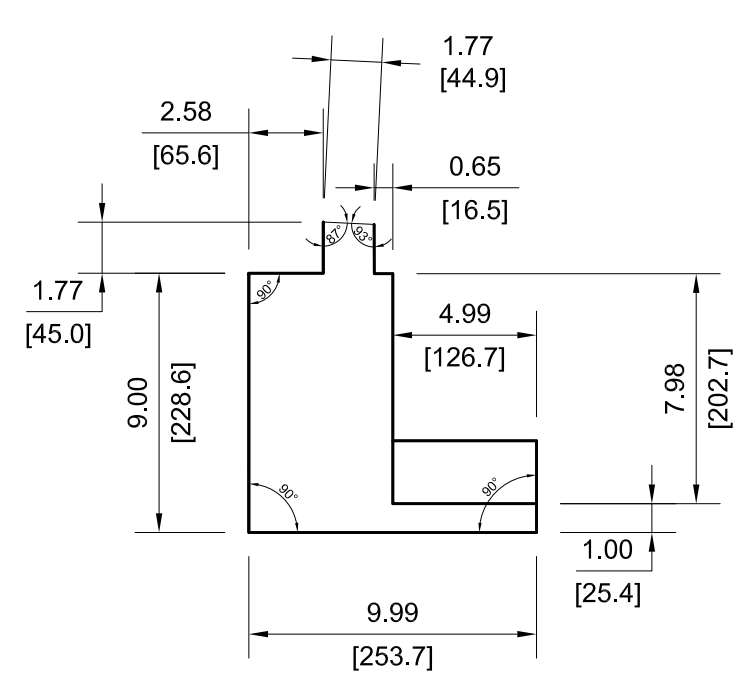

VIEW C8-150

NOTE: ALL VIEWS TAKEN AS TRUE VIEWS PARALLEL TO SURFACE OF PART

		DRAWING NUMBER			
		AES-D0002			
SIZE	SCALE	SHEET	OF	REVISION	
A3	NONE	150	167	F	

- 365

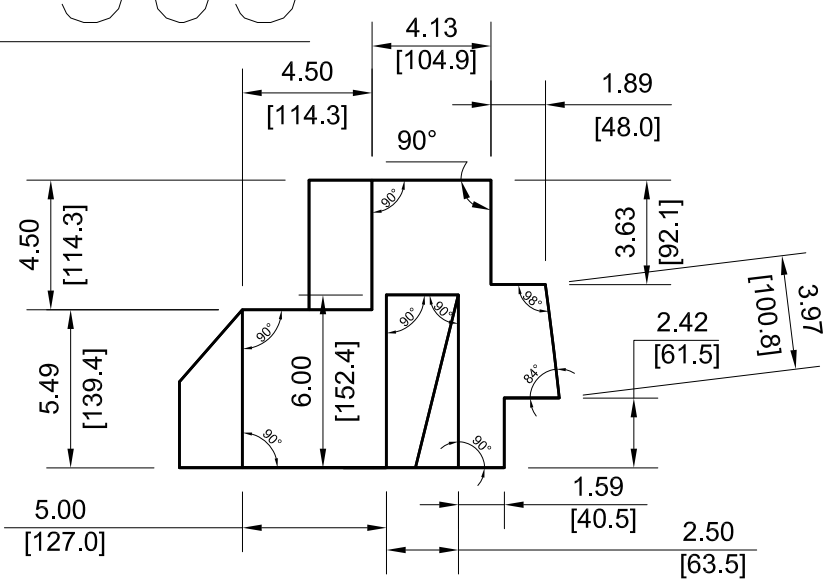

VIEW C4-151

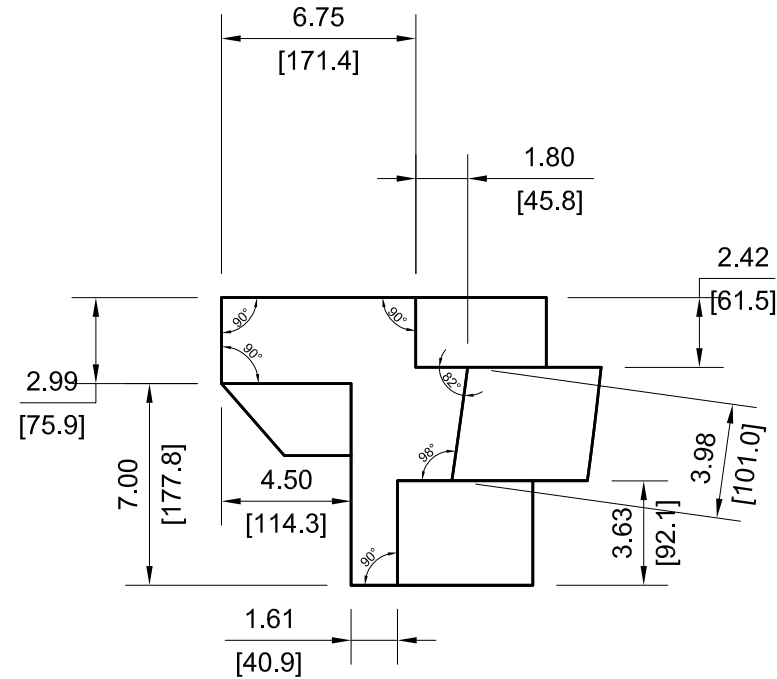

VIEW F4-151

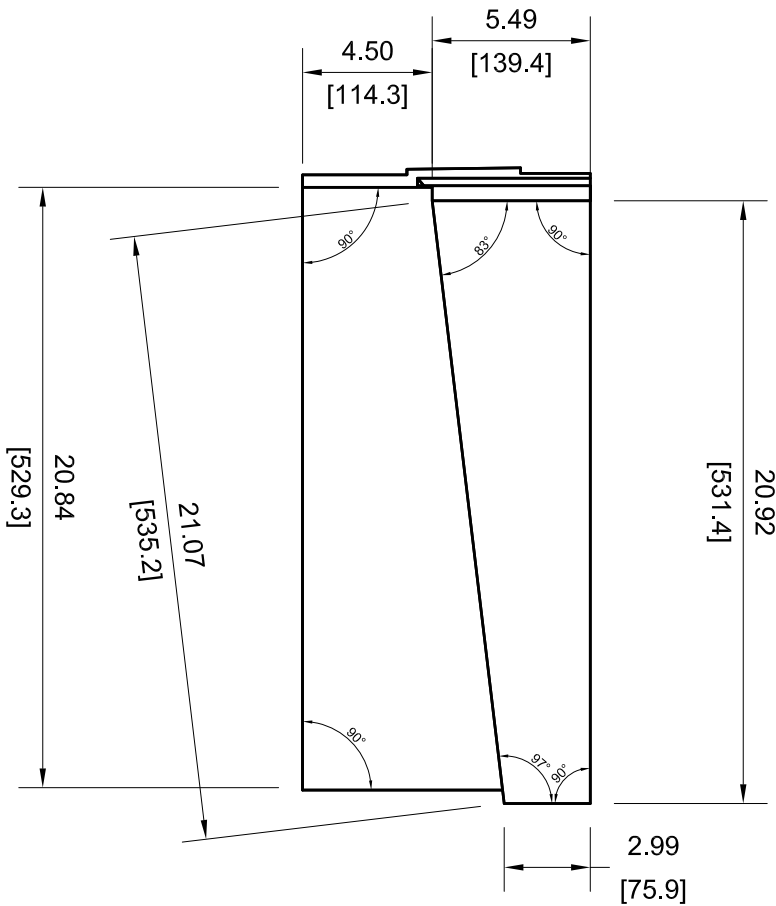
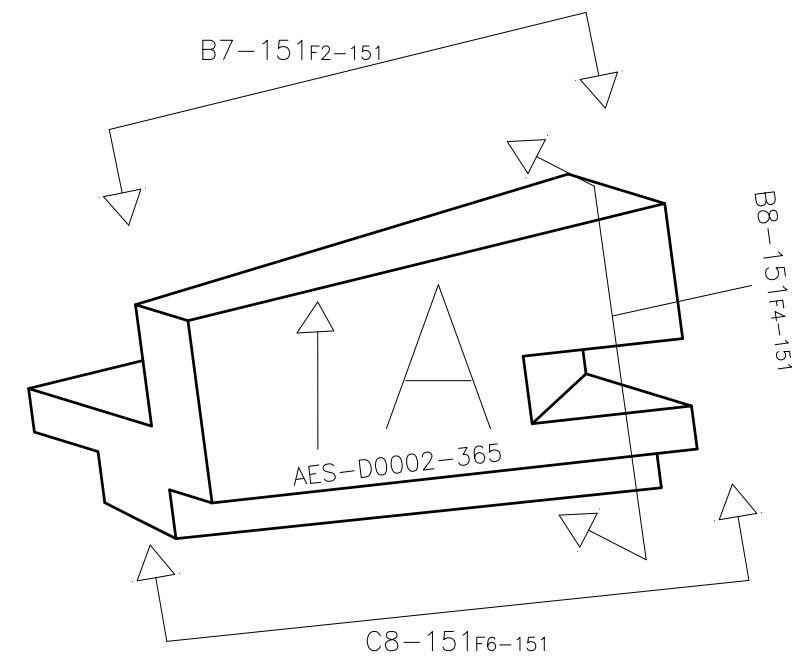

VIEW B7-151

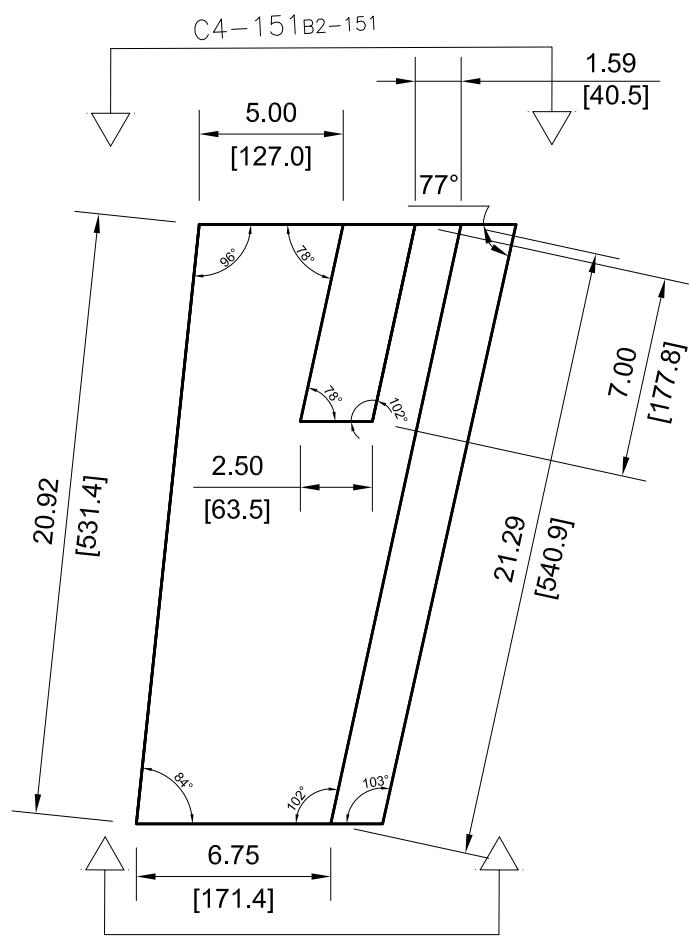

VIEW B8-151

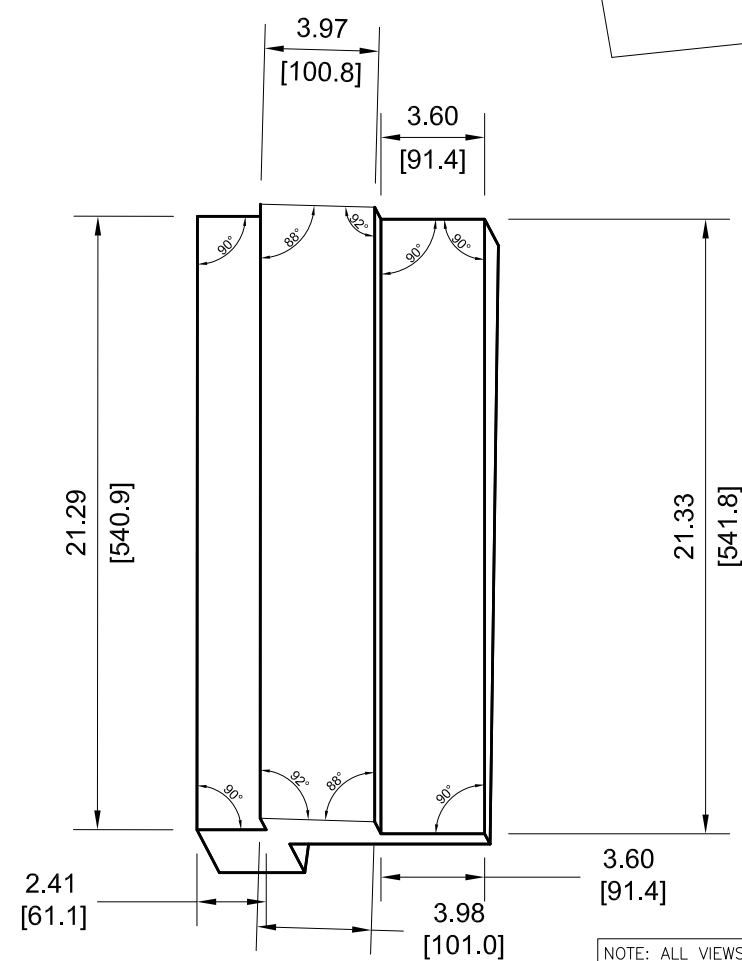

VIEW C8-151

NOTE: ALL VIEWS TAKEN AS TRUE VIEWS PARALLEL TO SURFACE OF PART

		DRAWING NUMBER			
		AES-D0002			
SIZE	SCALE	SHEET	OF	REVISION	
A3	NONE	151	167	F	

-367

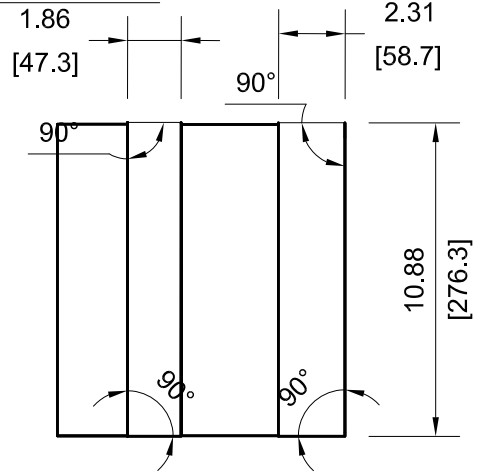

VIEW C4-152

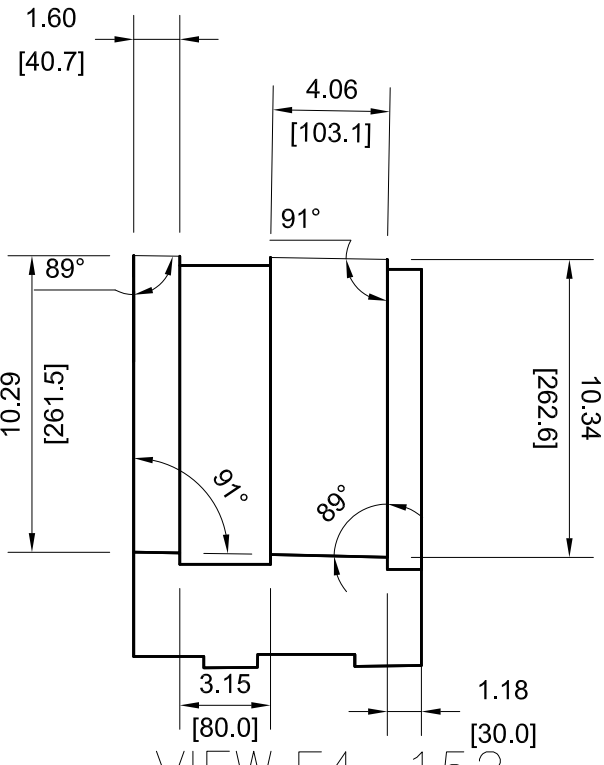

VIEW F4-152

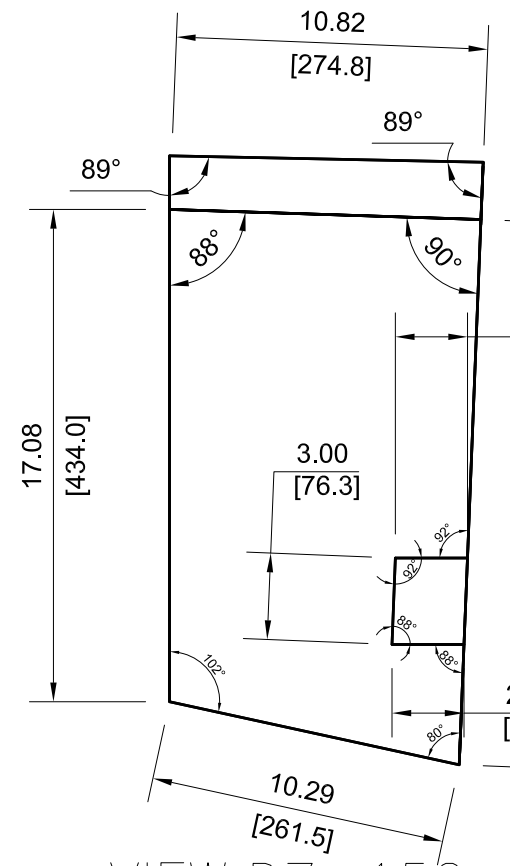
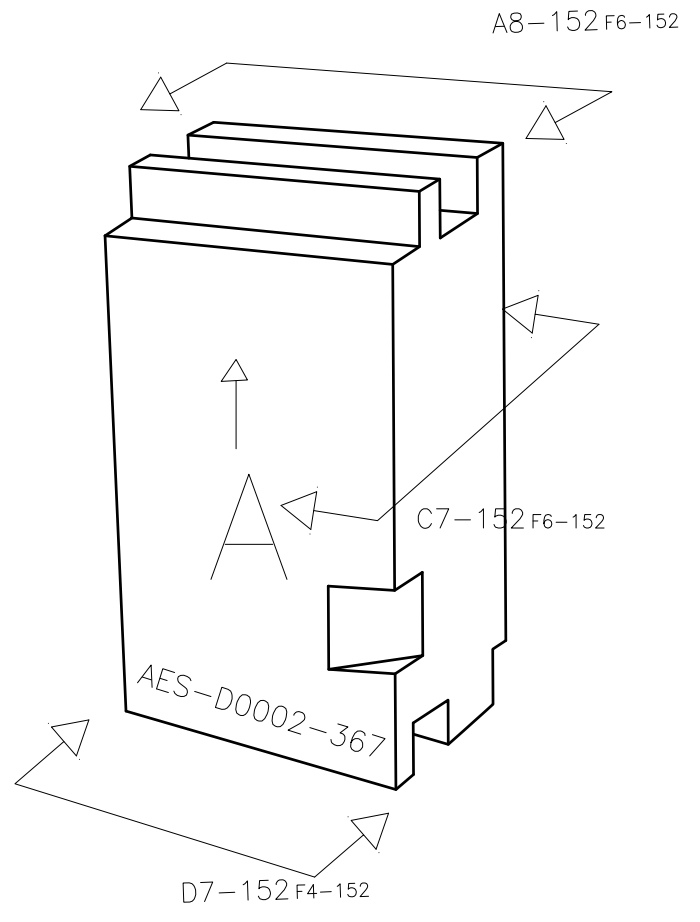

VIEW D7-152

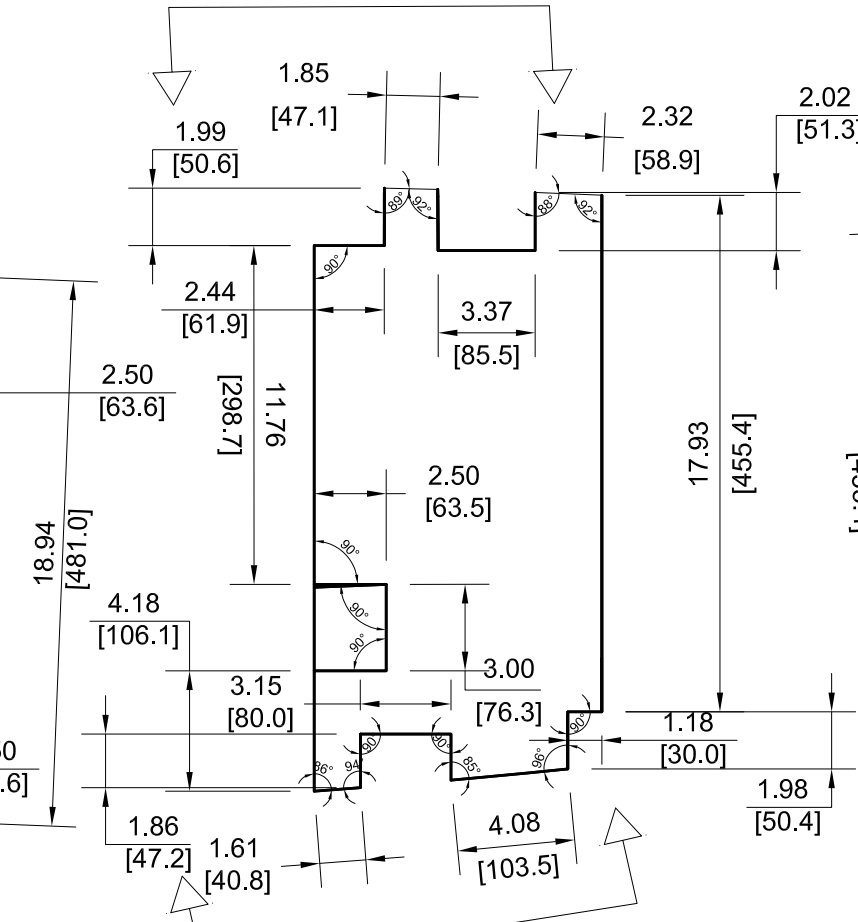

VIEW C7-152

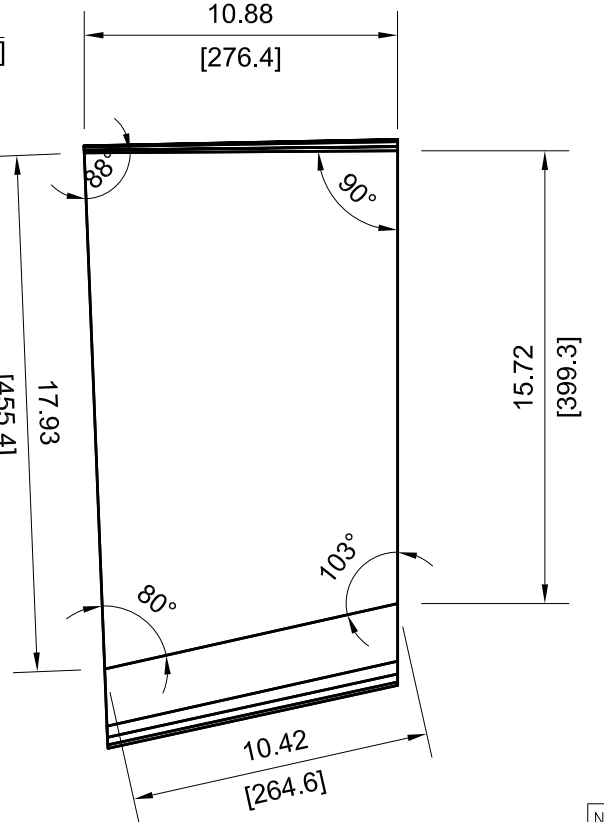

VIEW A8-152

NOTE: ALL VIEWS TAKEN AS TRUE VIEWS PARALLEL TO SURFACE OF PART

		DRAWING NUMBER			
		AES-D0002			
SIZE	SCALE	SHEET	OF	REVISION	
A3	NONE	152	167	F	

— 369

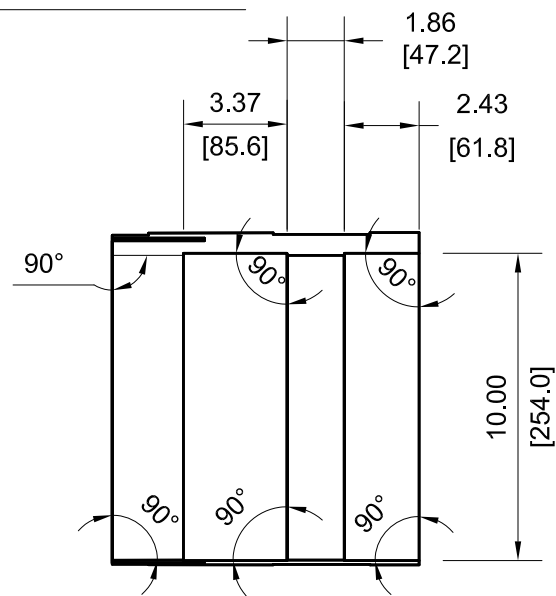

VIEW C4-153

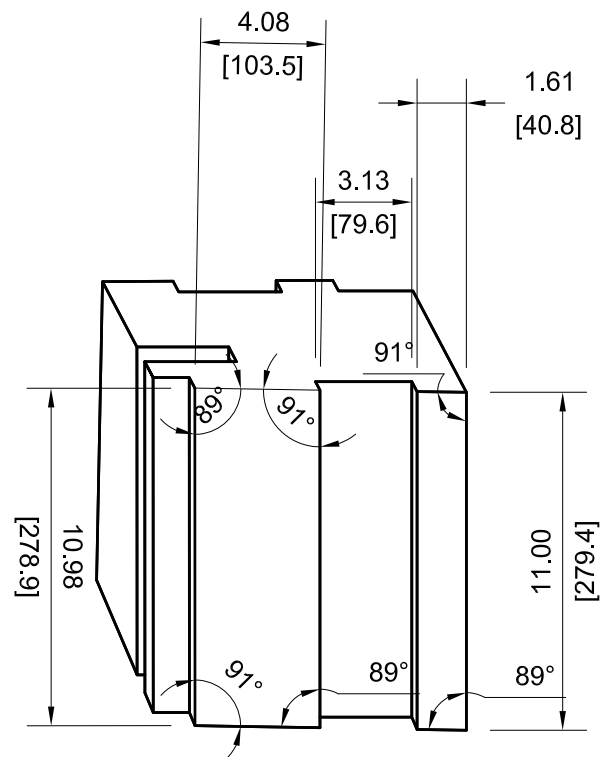

VIEW F4-153

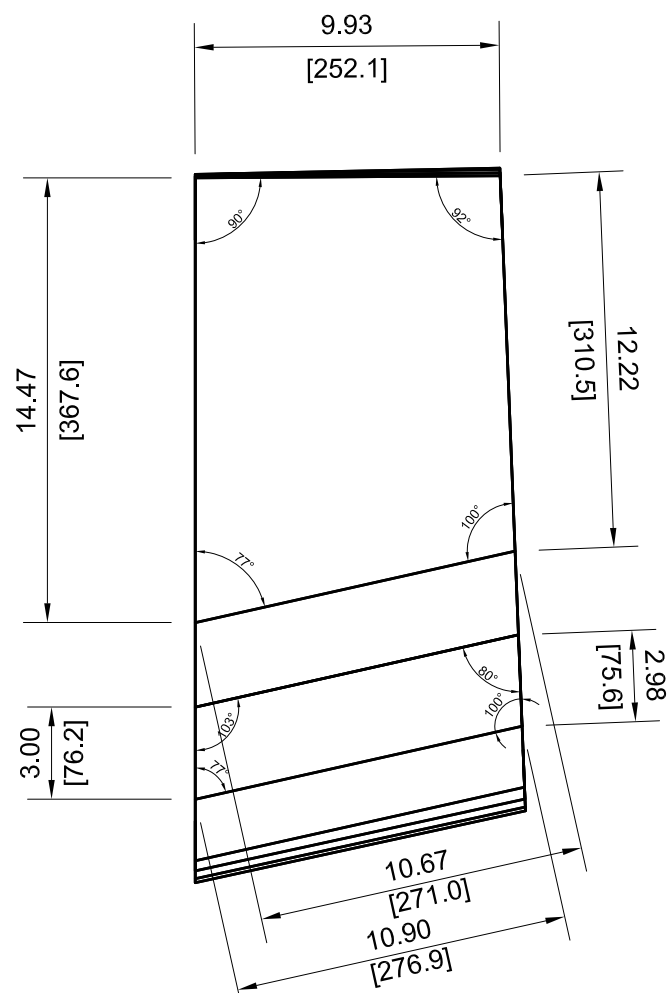
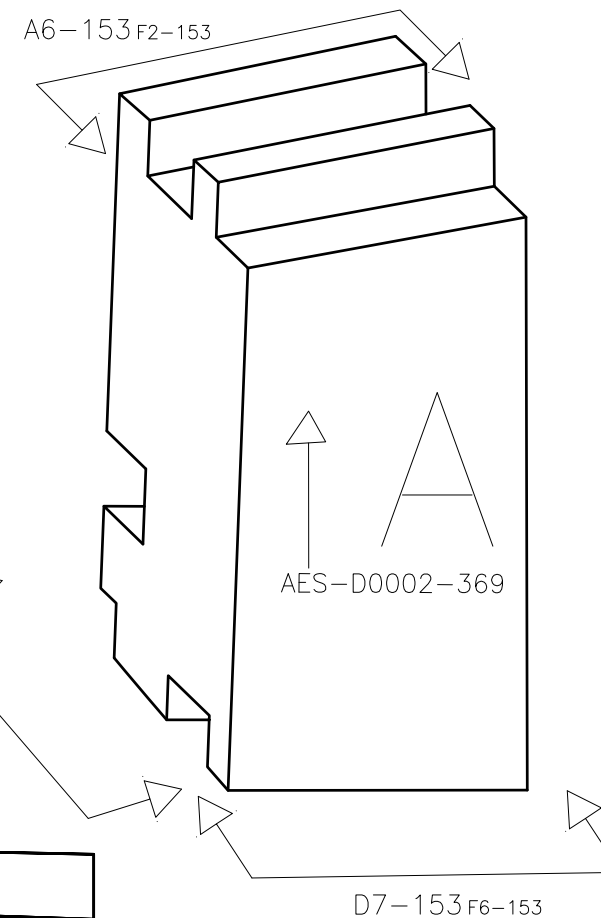

VIEW A6-153

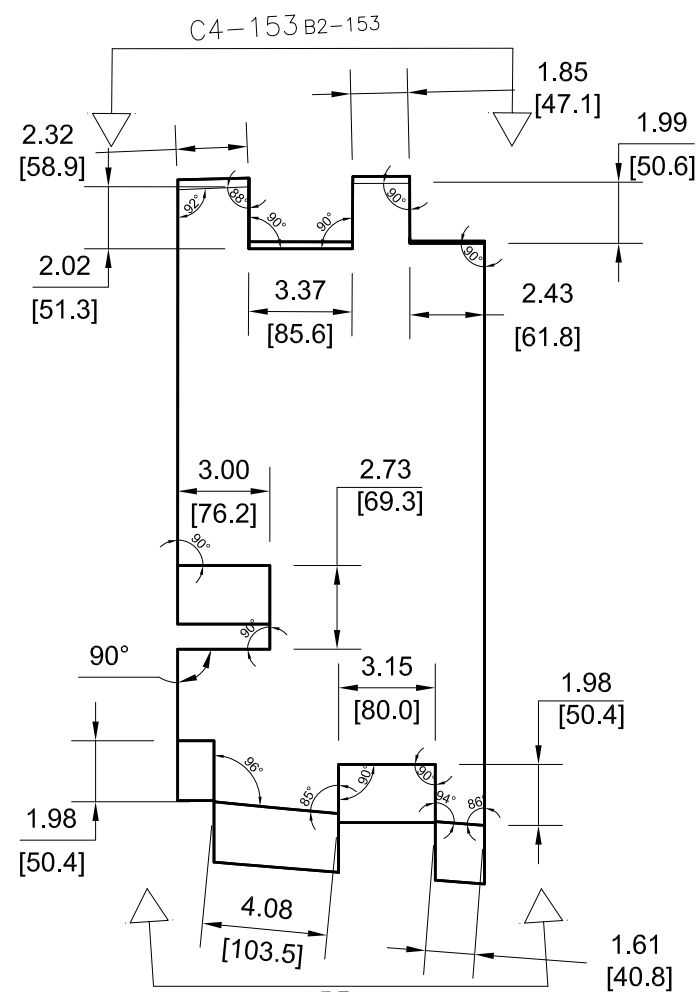

VIEW C6-153

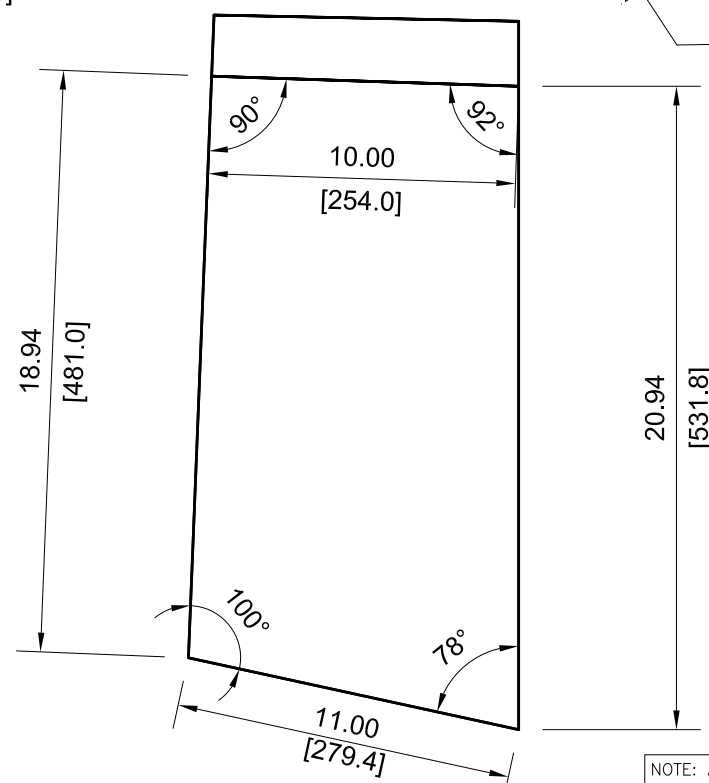

VIEW D7-153

NOTE: ALL VIEWS TAKEN AS TRUE VIEWS PARALLEL TO SURFACE OF PART

		DRAWING NUMBER			
		AES-D0002			
SIZE	SCALE	SHEET	OF	REVISION	
A3	NONE	153	167	F	

-371

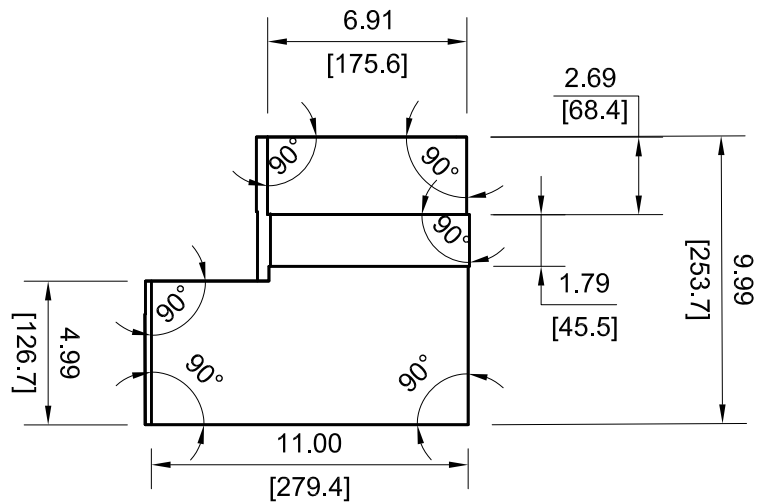

VIEW C4-154

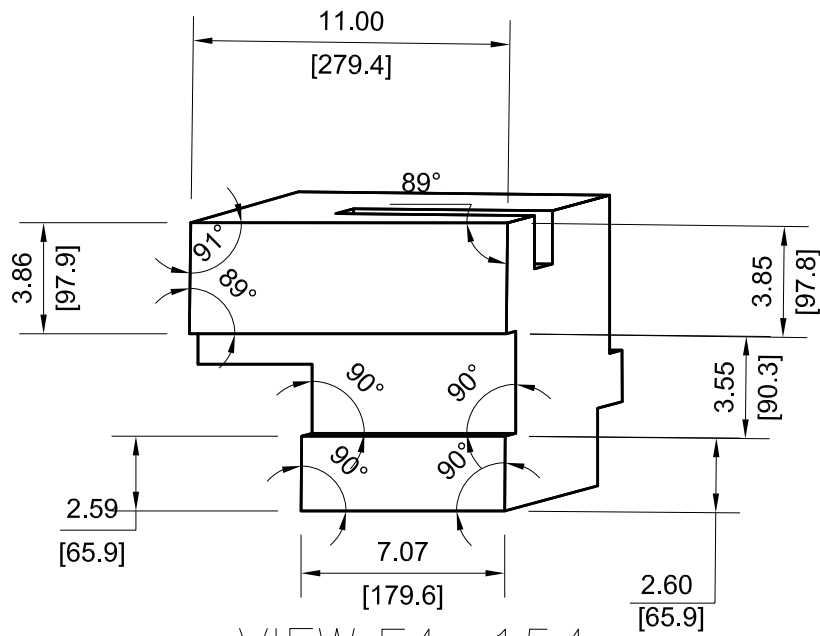

VIEW F4-154

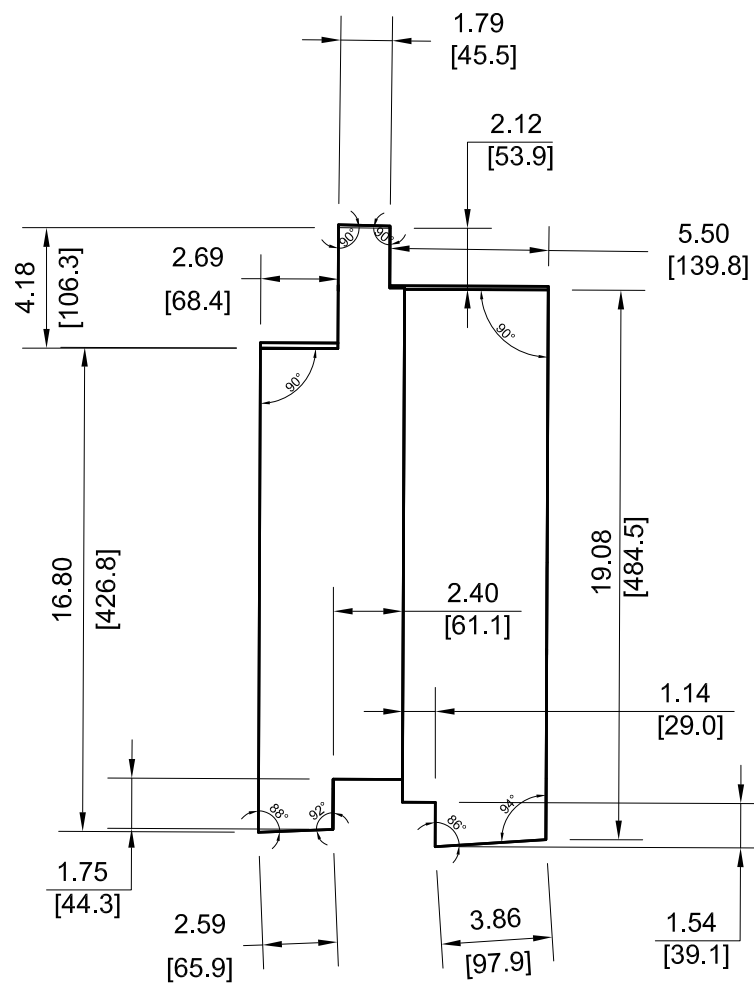
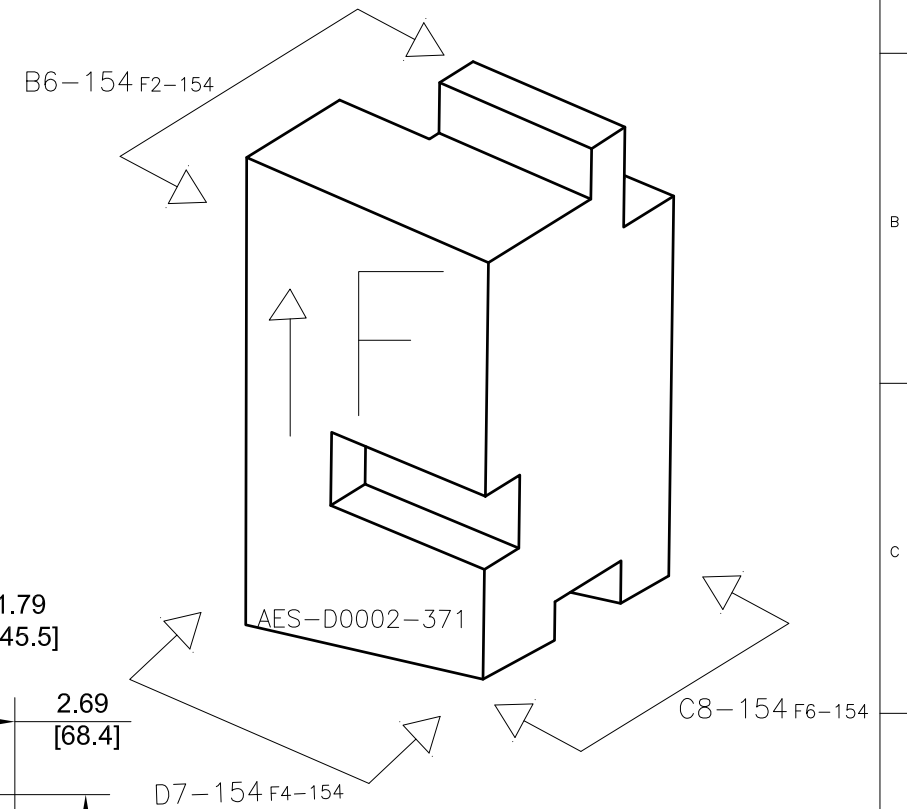

VIEW B6-154

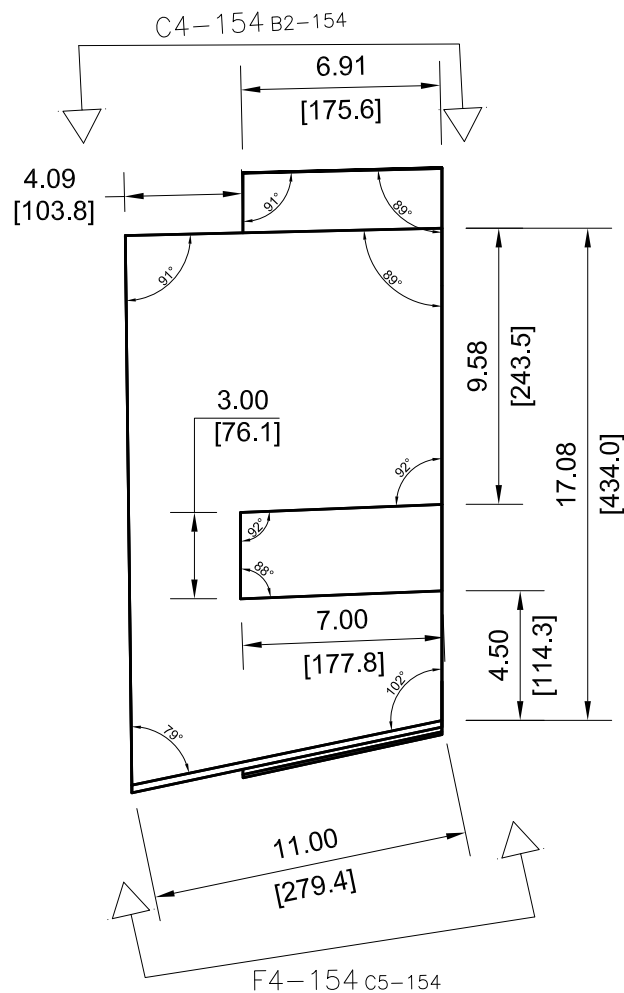

VIEW D7-154

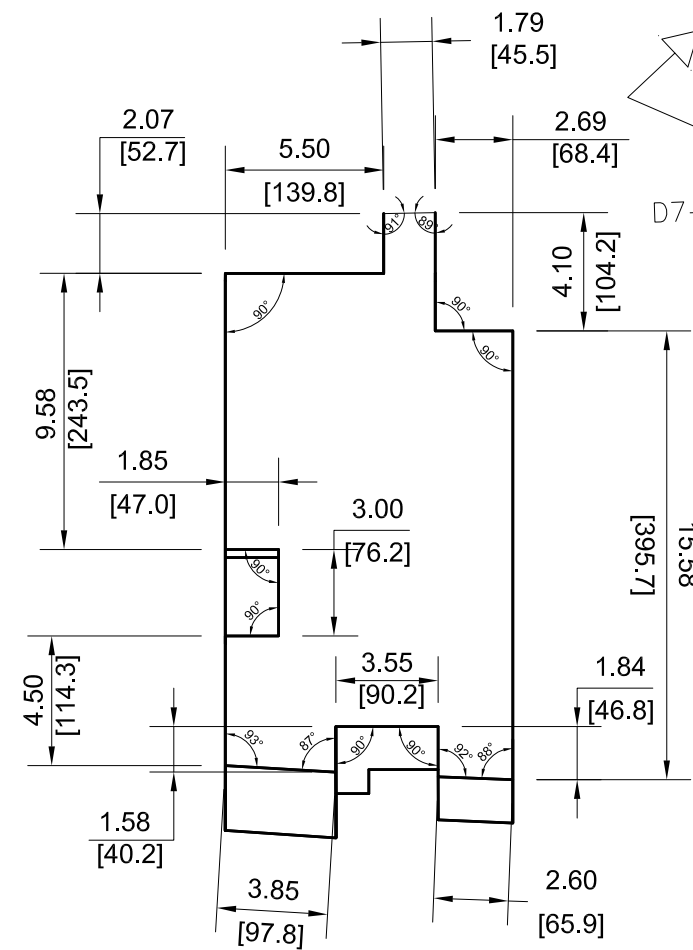

VIEW C8-154

NOTE: ALL VIEWS TAKEN AS TRUE VIEWS PARALLEL TO SURFACE OF PART

		DRAWING NUMBER			
		AES-D0002			
SIZE	SCALE	SHEET	OF	REVISION	
A3	NONE	154	167	F	

- 373

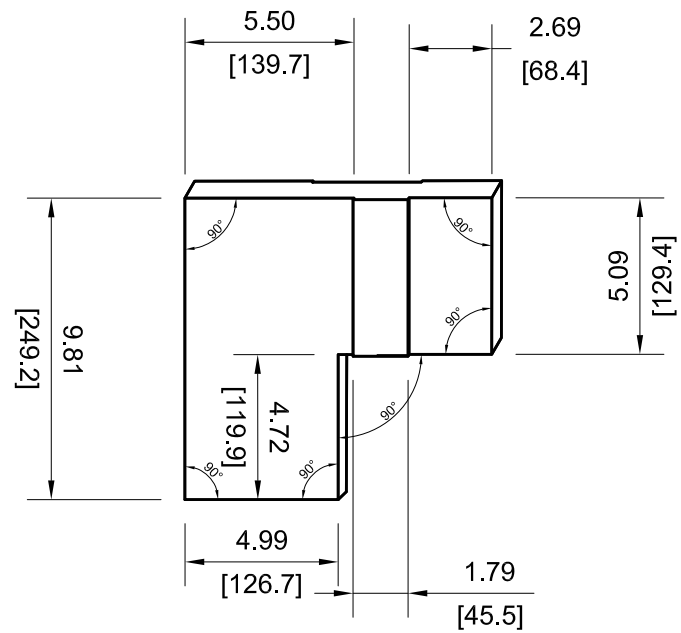

VIEW C4-155

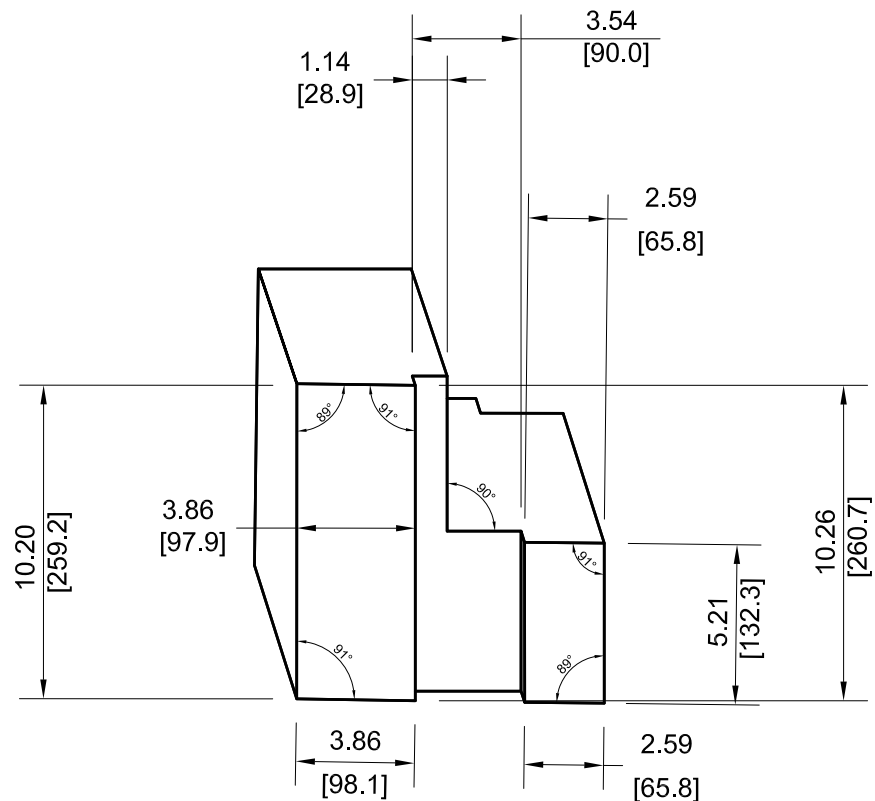

VIEW F4-155

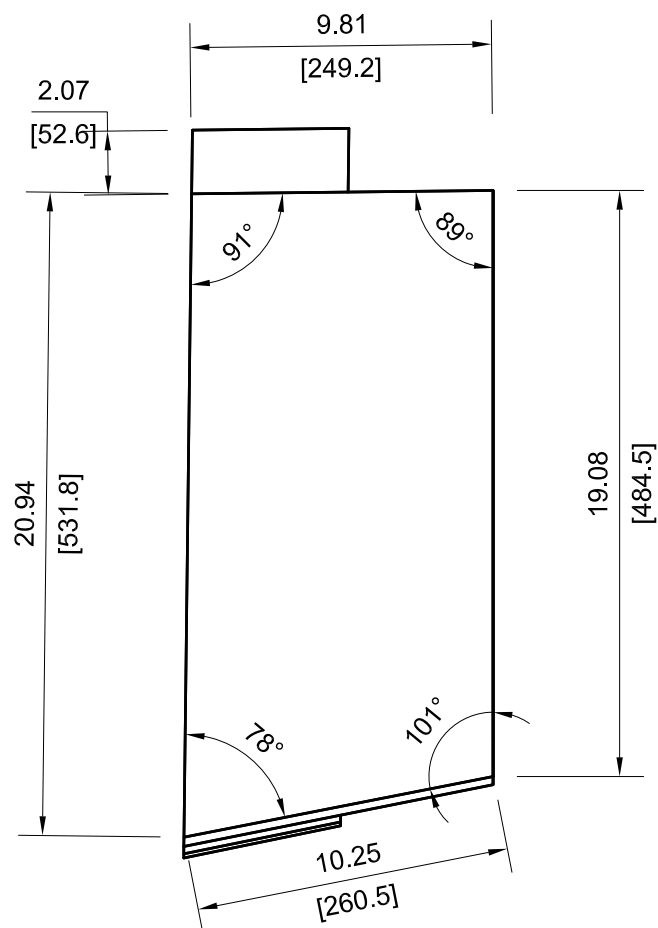
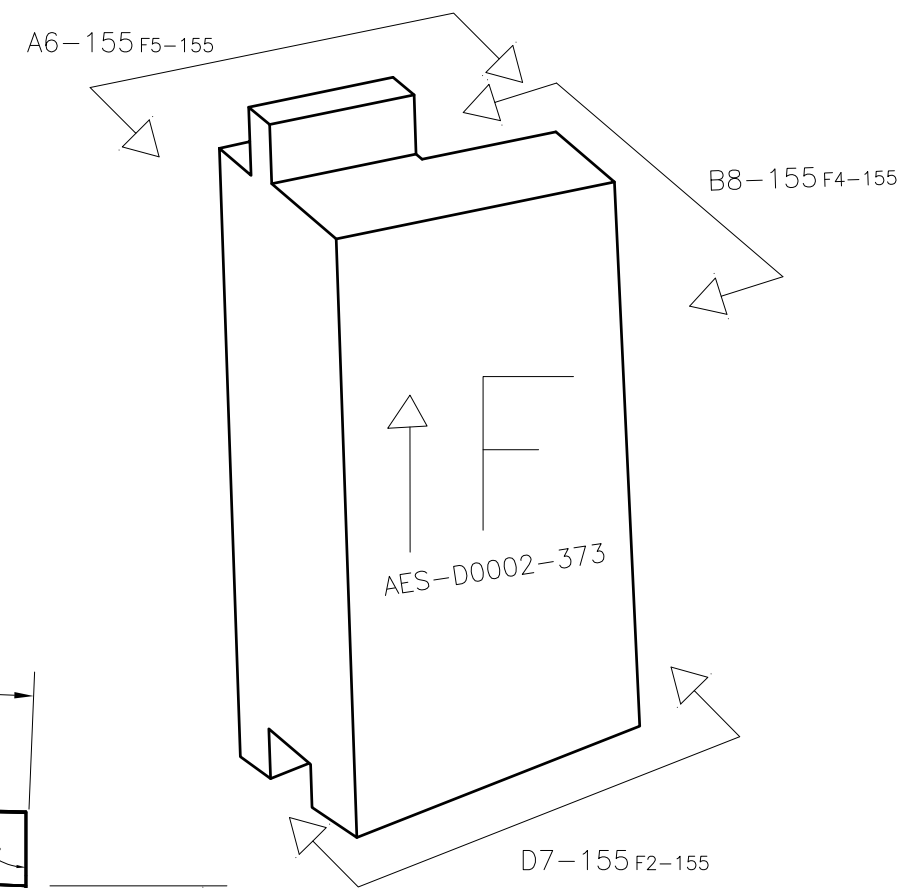

VIEW D7-155

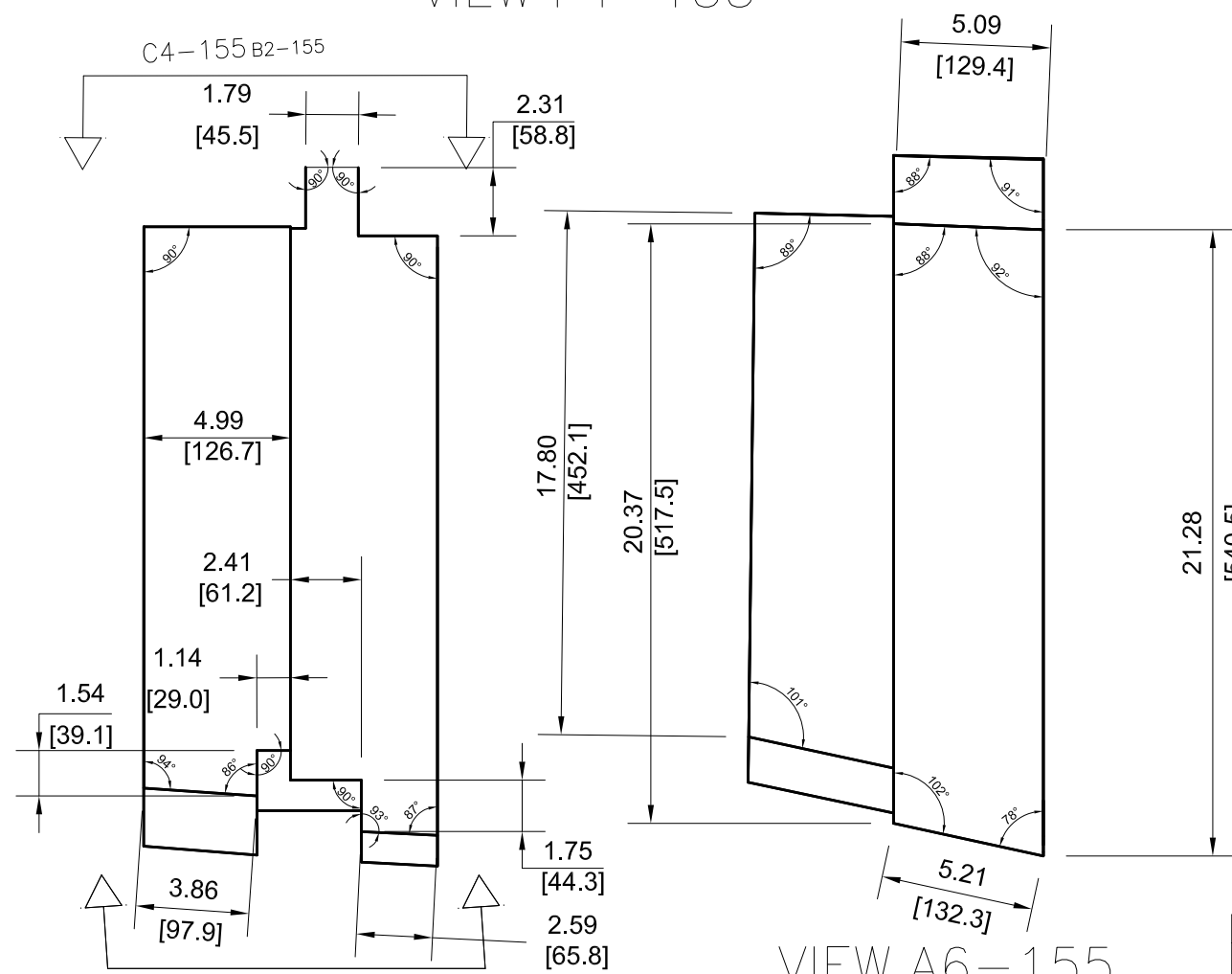

VIEW B8-155

VIEW A6-155

NOTE: ALL VIEWS TAKEN AS TRUE VIEWS PARALLEL TO SURFACE OF PART

		DRAWING NUMBER			
		AES-D0002			
SIZE	SCALE	SHEET	OF	REVISION	
A3	NONE	155	167	F	

- 375

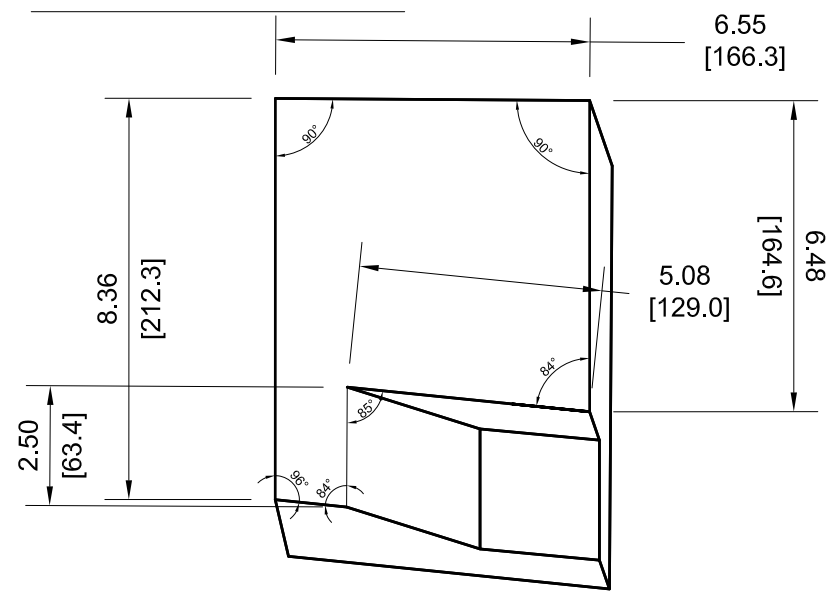

VIEW C4-156

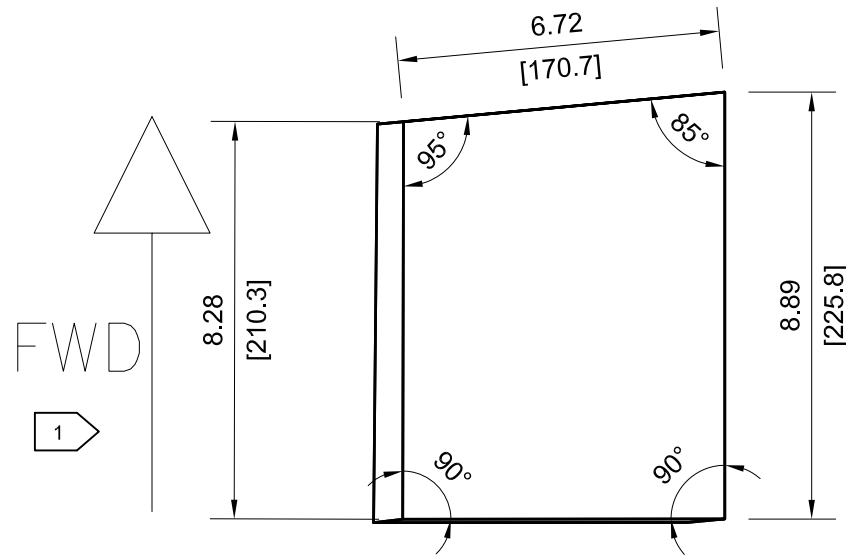

VIEW F4-156

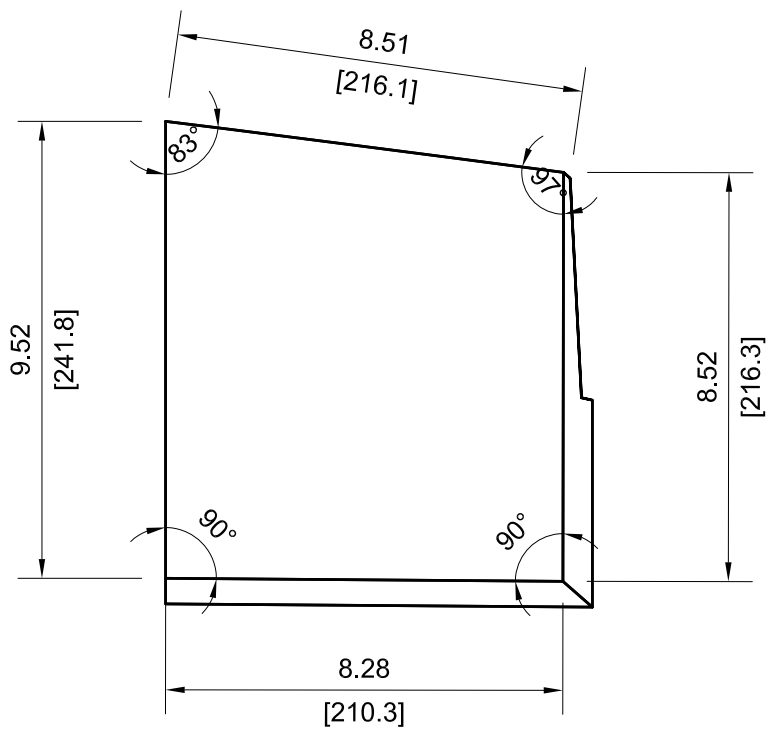
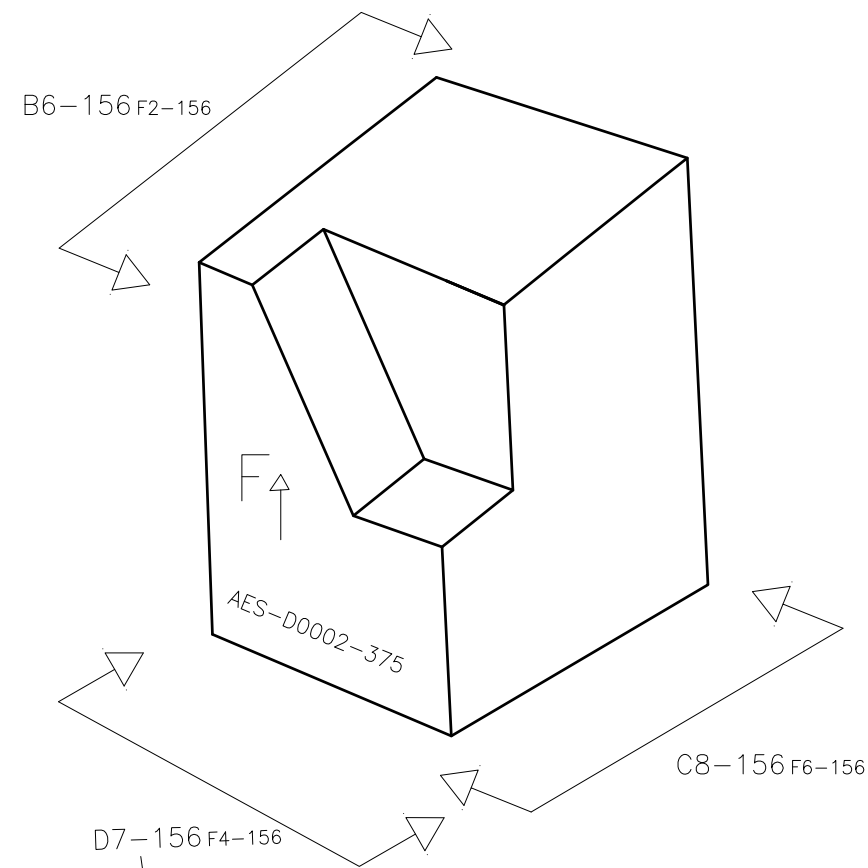

VIEW B6-156

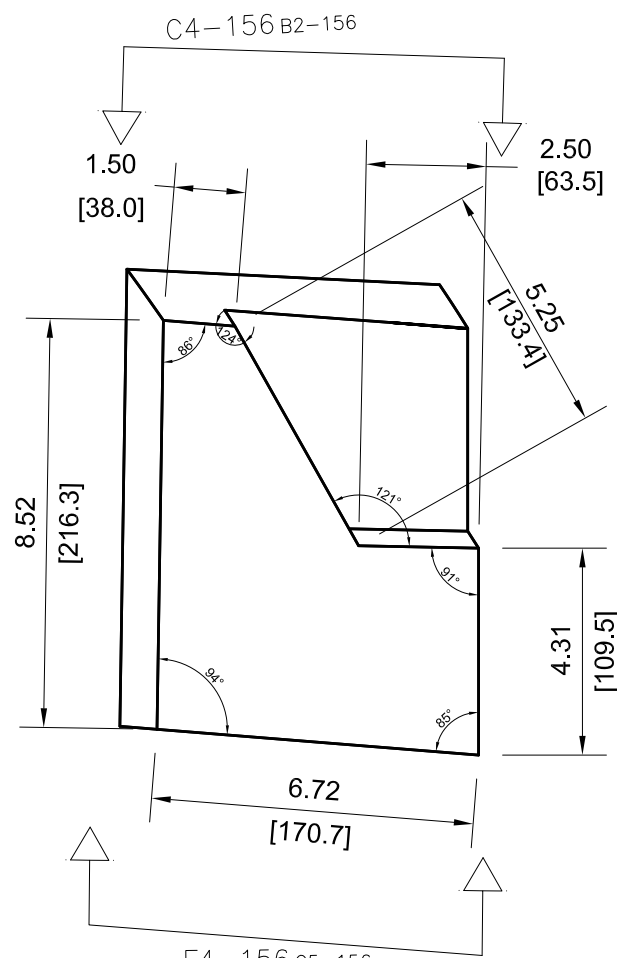

VIEW D7-156

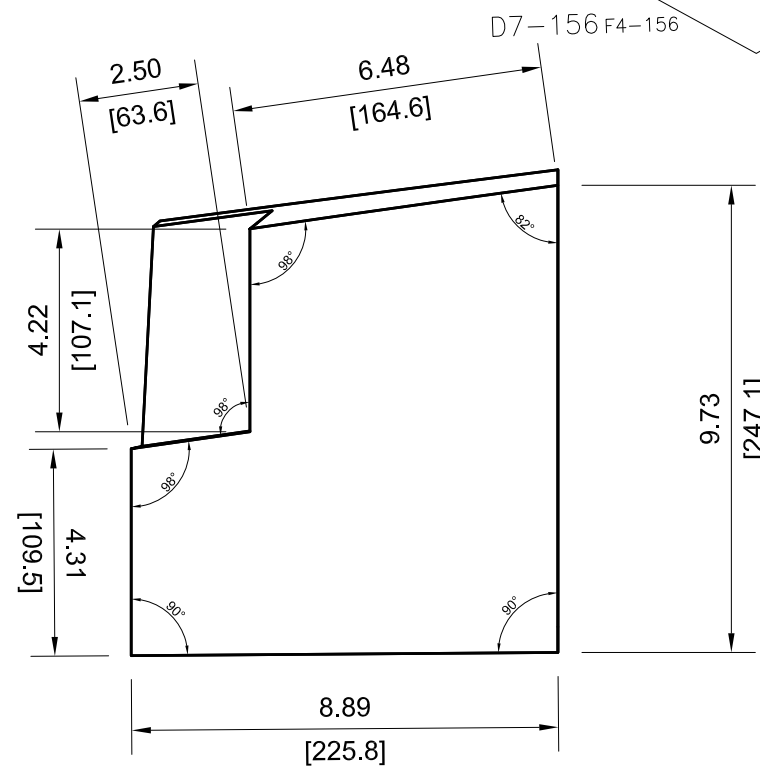

VIEW C8-156

NOTE: ALL VIEWS TAKEN AS TRUE VIEWS PARALLEL TO SURFACE OF PART

		DRAWING NUMBER			
		AES-D0002			
SIZE	SCALE	SHEET	OF	REVISION	
A3	NONE	156	167	F	

- 377

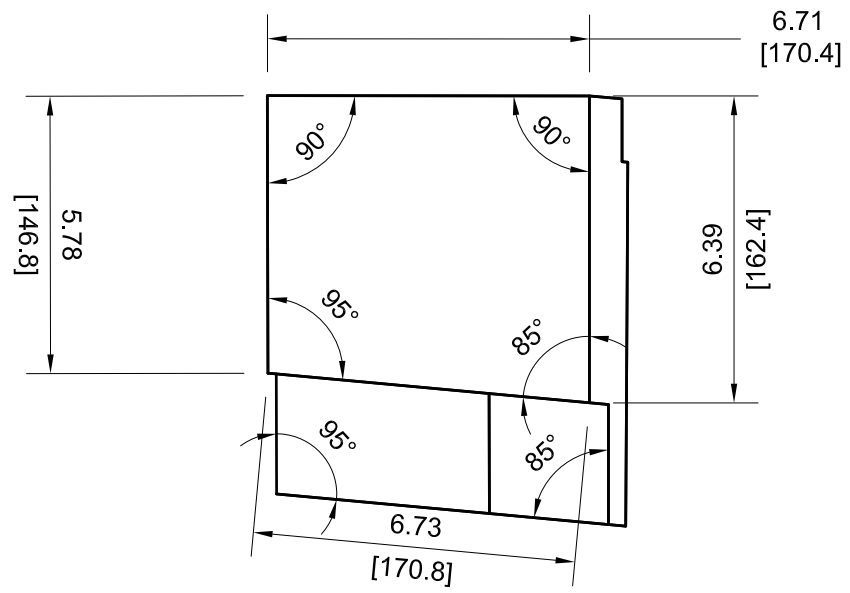

VIEW C4-157

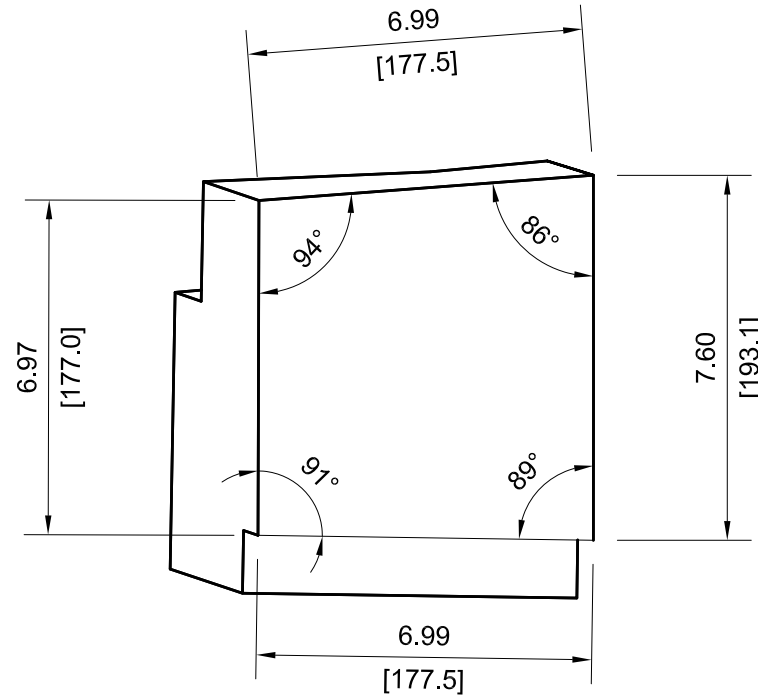

VIEW F4-157

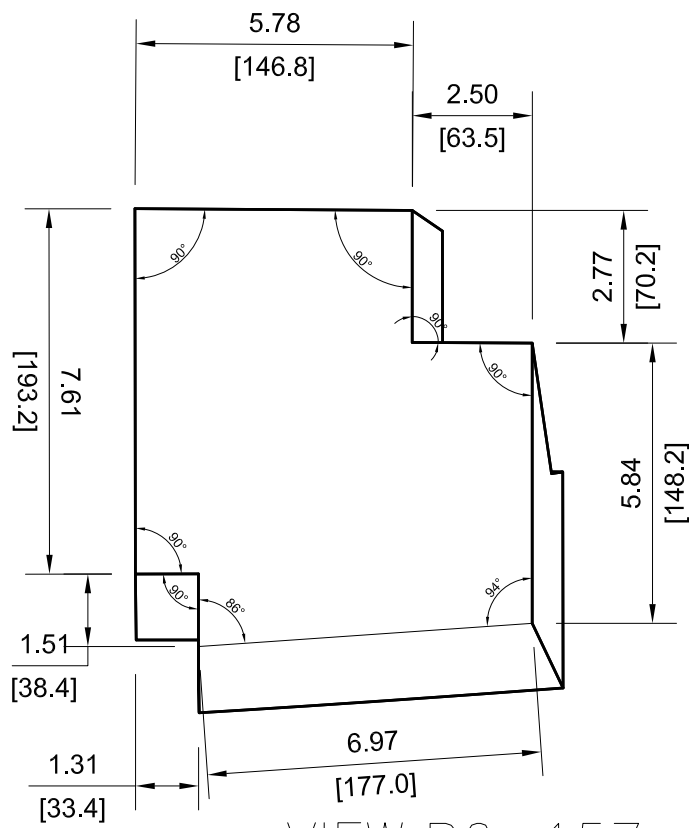
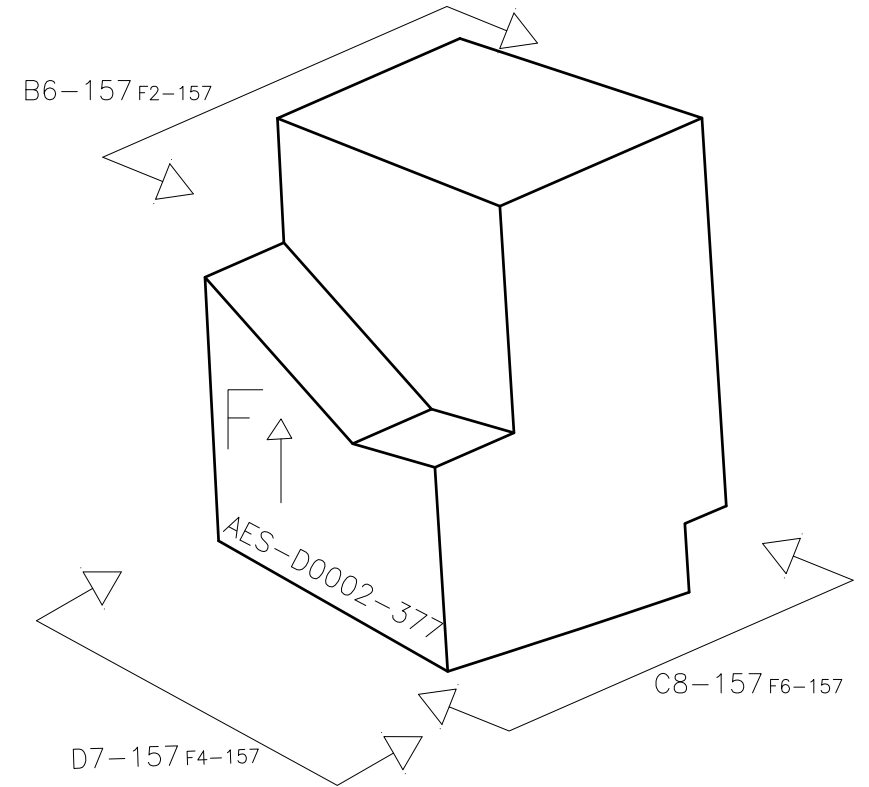

VIEW B6-157

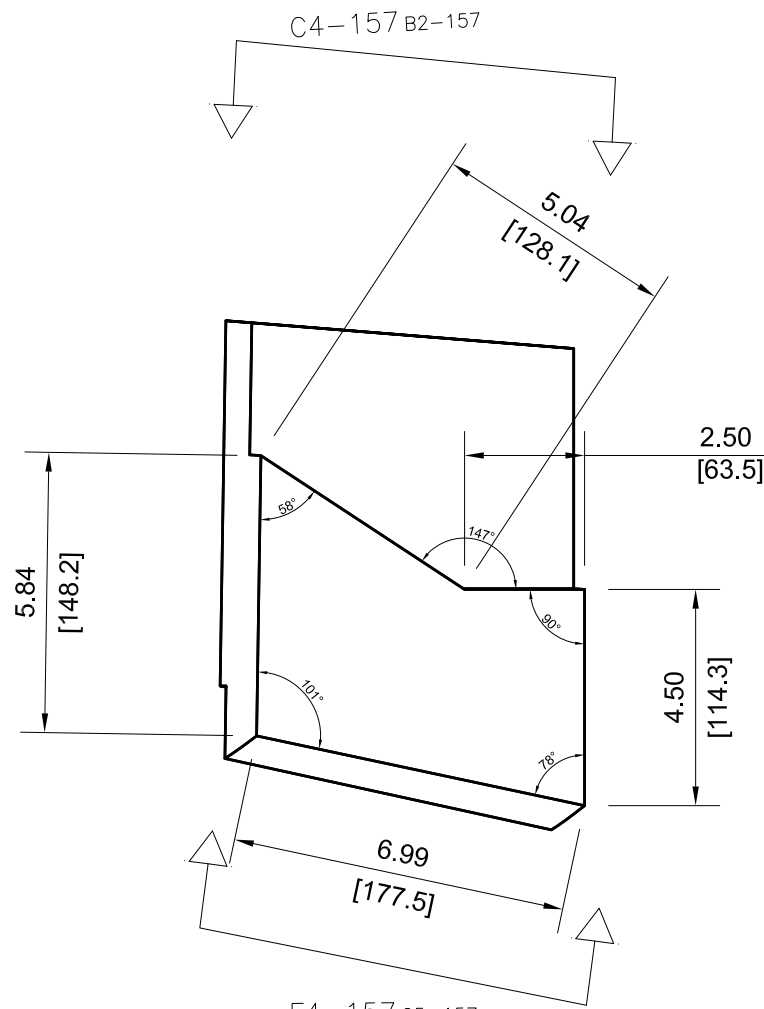

F4-157 C5-157
VIEW D7-157

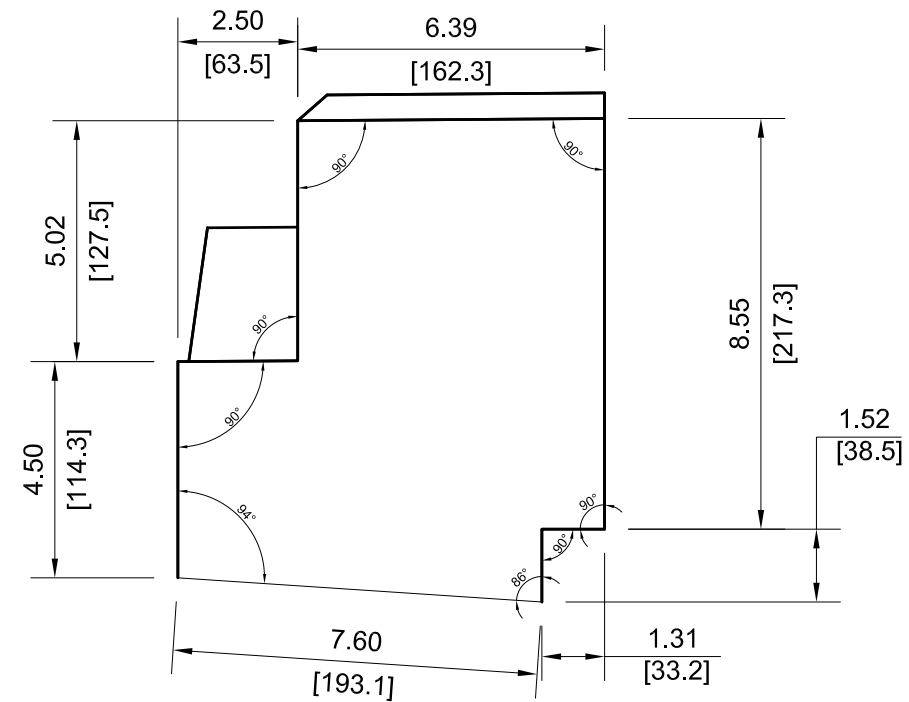

VIEW C8-157

NOTE: ALL VIEWS TAKEN AS TRUE VIEWS PARALLEL TO SURFACE OF PART

		DRAWING NUMBER			
		AES-D0002			
SIZE	SCALE	SHEET	OF	REVISION	
A3	NONE	157	167	F	

-379

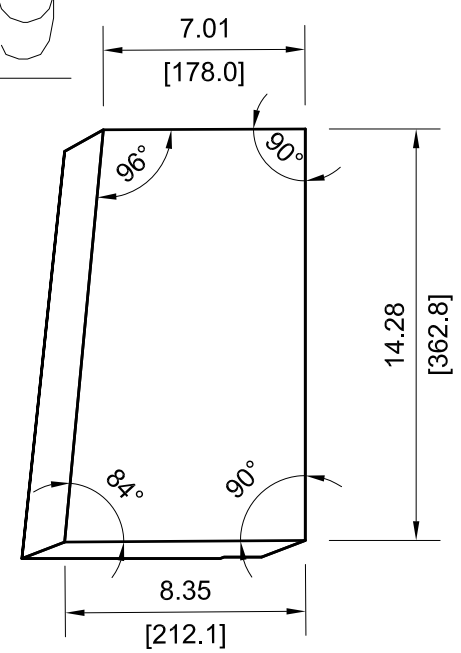

VIEW C4-158

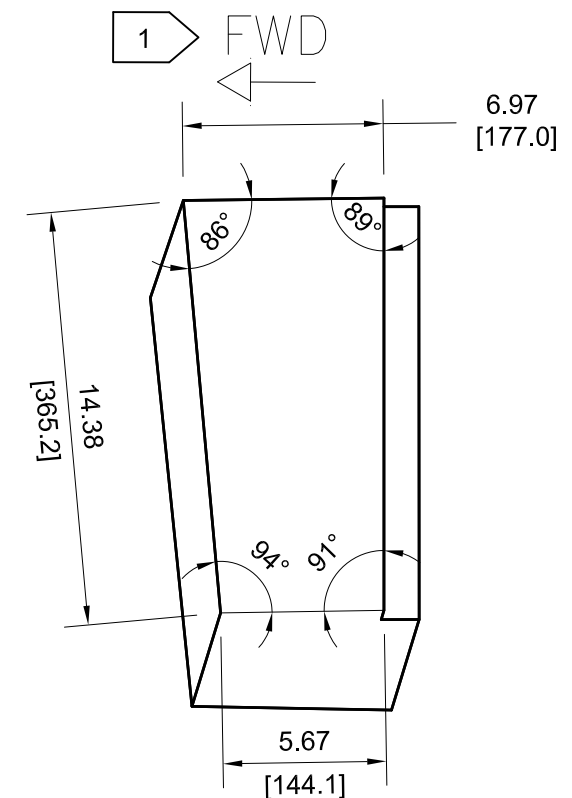

VIEW F4-158

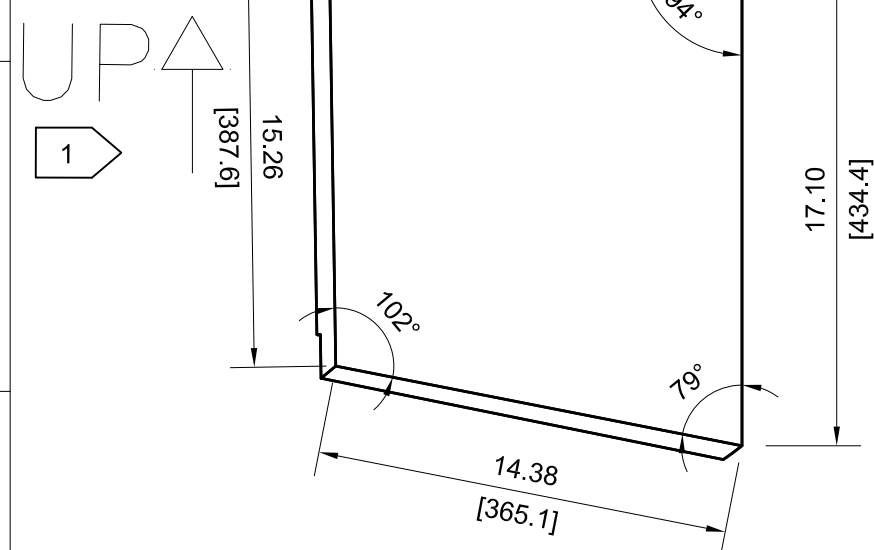
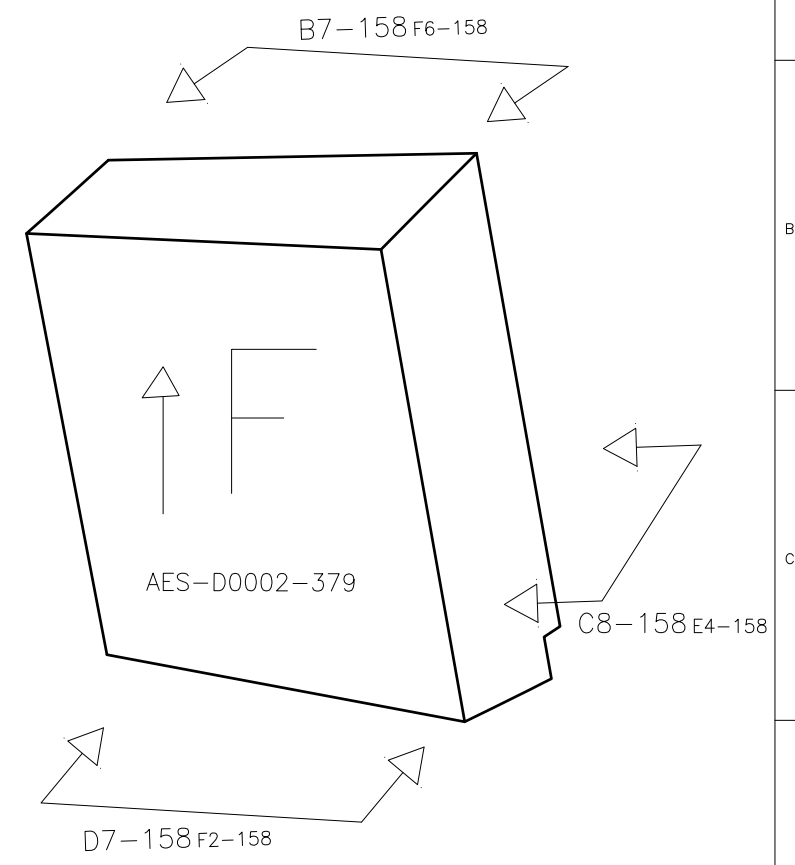

VIEW D7-158

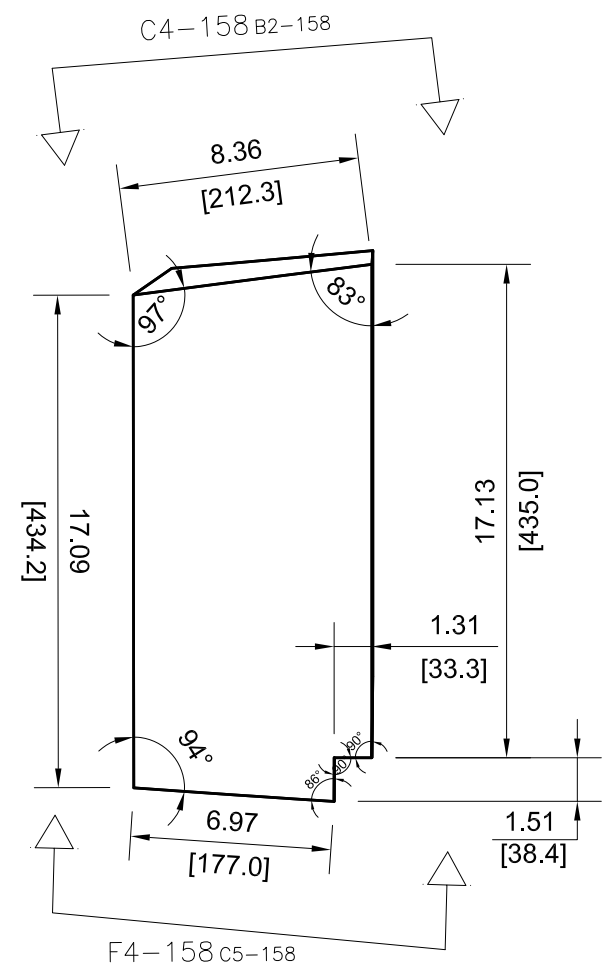

VIEW C8-158

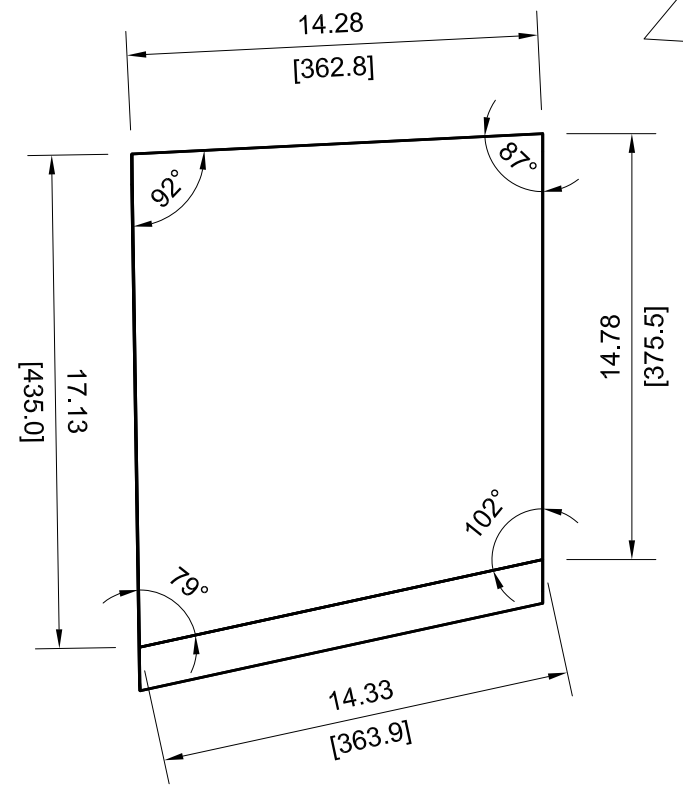

VIEW B7-158

UP ↑
1

1 FWD ←

NOTE: ALL VIEWS TAKEN AS TRUE VIEWS PARALLEL TO SURFACE OF PART

	DRAWING NUMBER				
	AES-D0002				
SIZE	SCALE	SHEET	OF	REVISION	
A3	NONE	158	167	F	

381

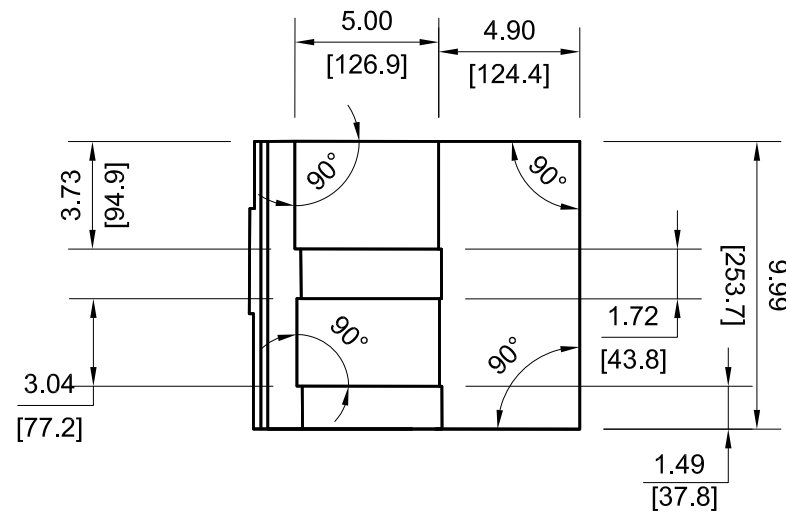

VIEW C4-159

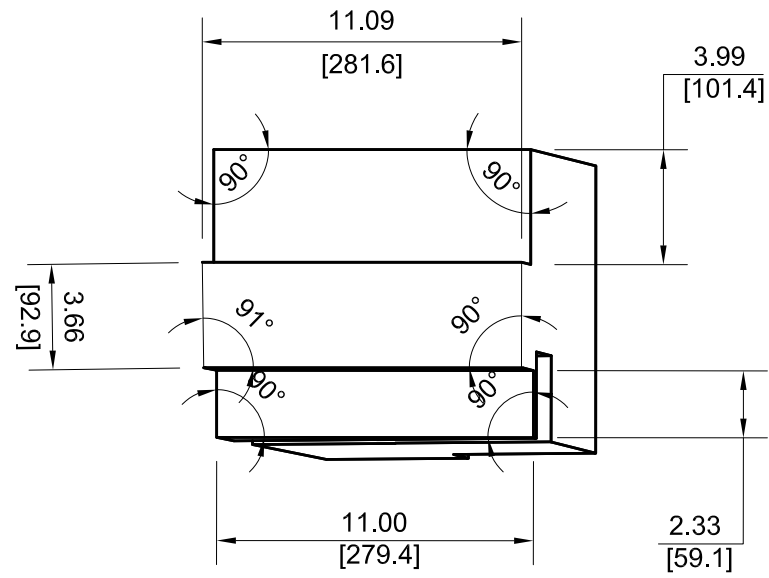

VIEW F4-159

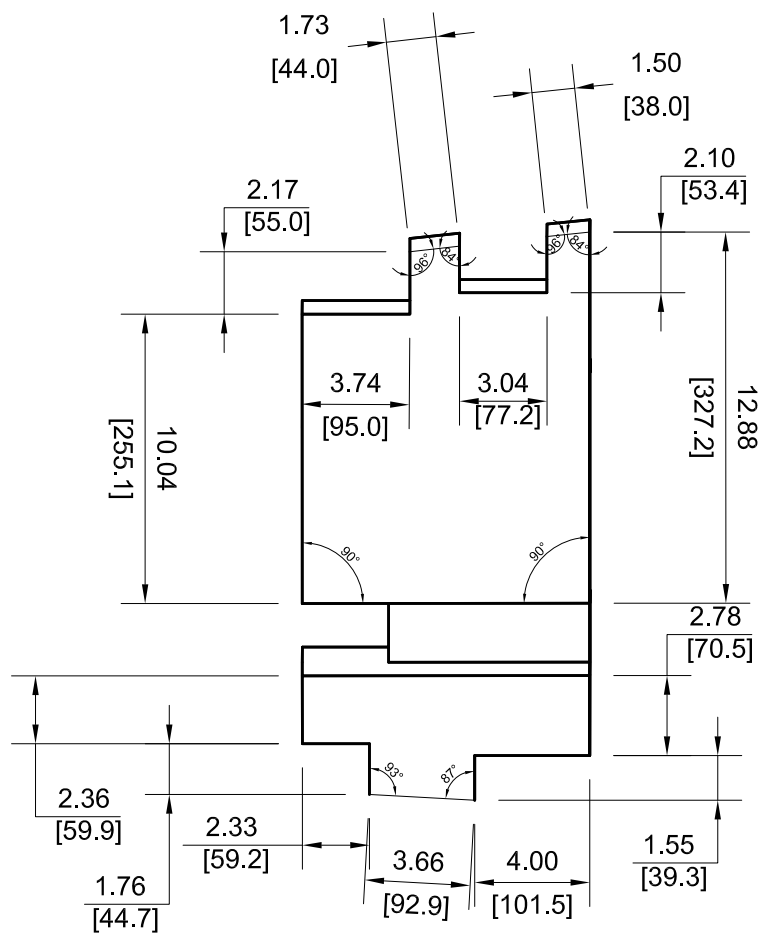
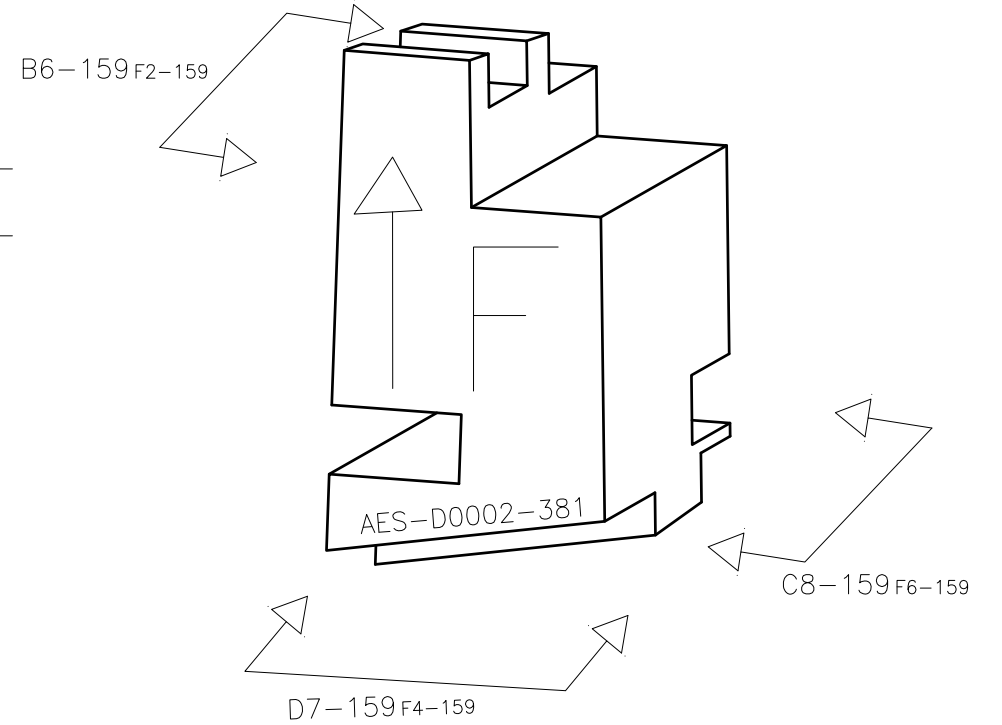

VIEW B6-159

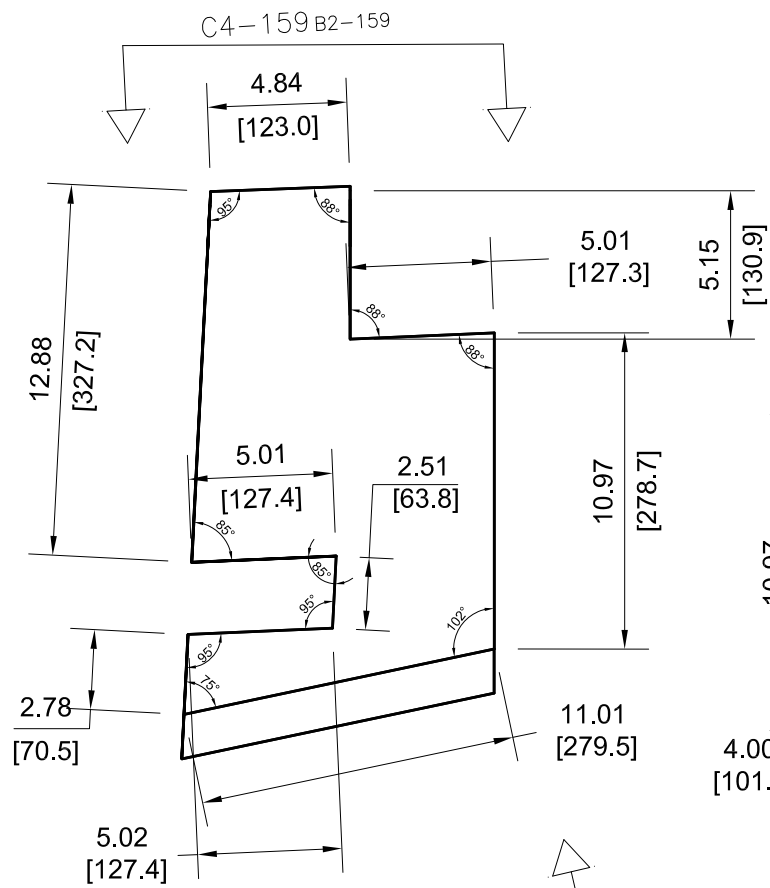

VIEW D7-159

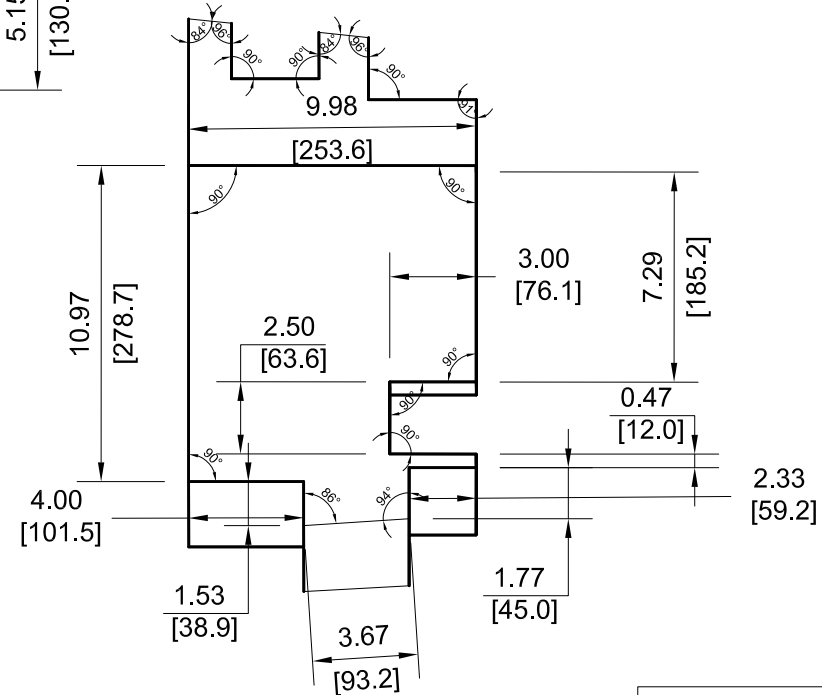

VIEW C8-159

NOTE: ALL VIEWS TAKEN AS TRUE VIEWS PARALLEL TO SURFACE OF PART

		DRAWING NUMBER			
		AES-D0002			
SIZE	SCALE	SHEET	OF	REVISION	
A3	NONE	159	167	F	

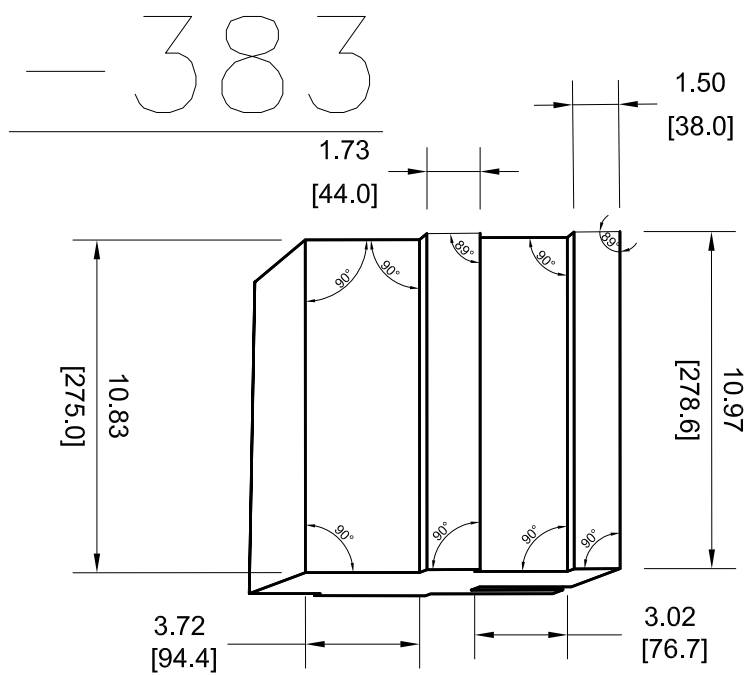

VIEW C4-160

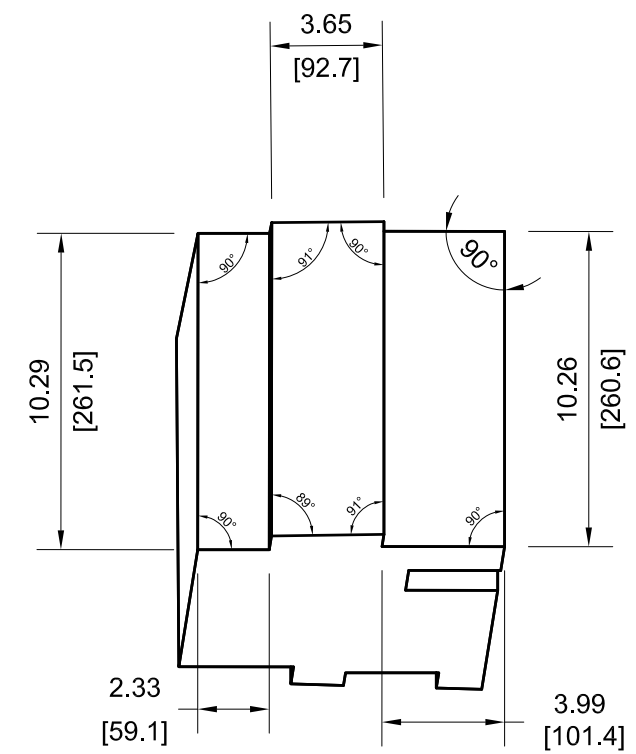

VIEW F4-160

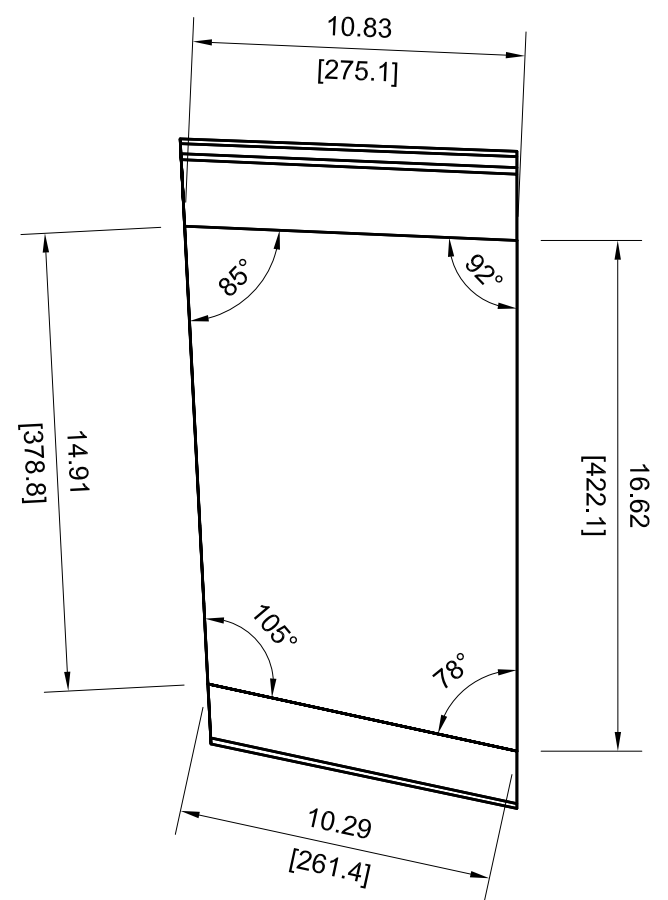
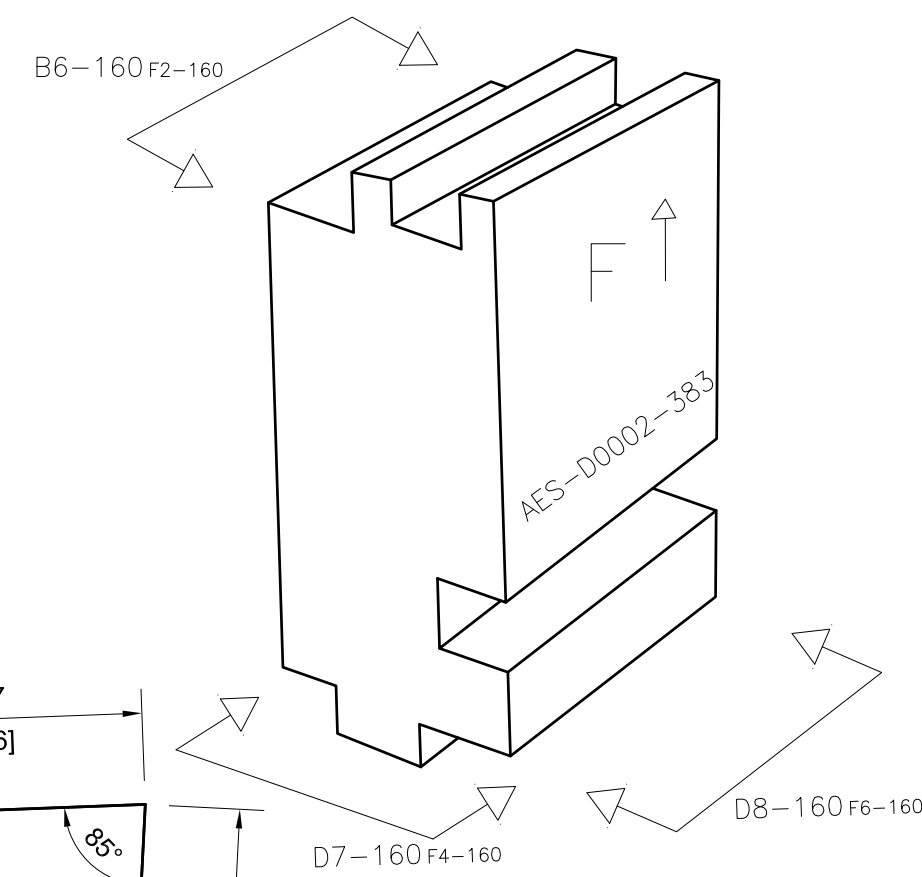

VIEW B6-160

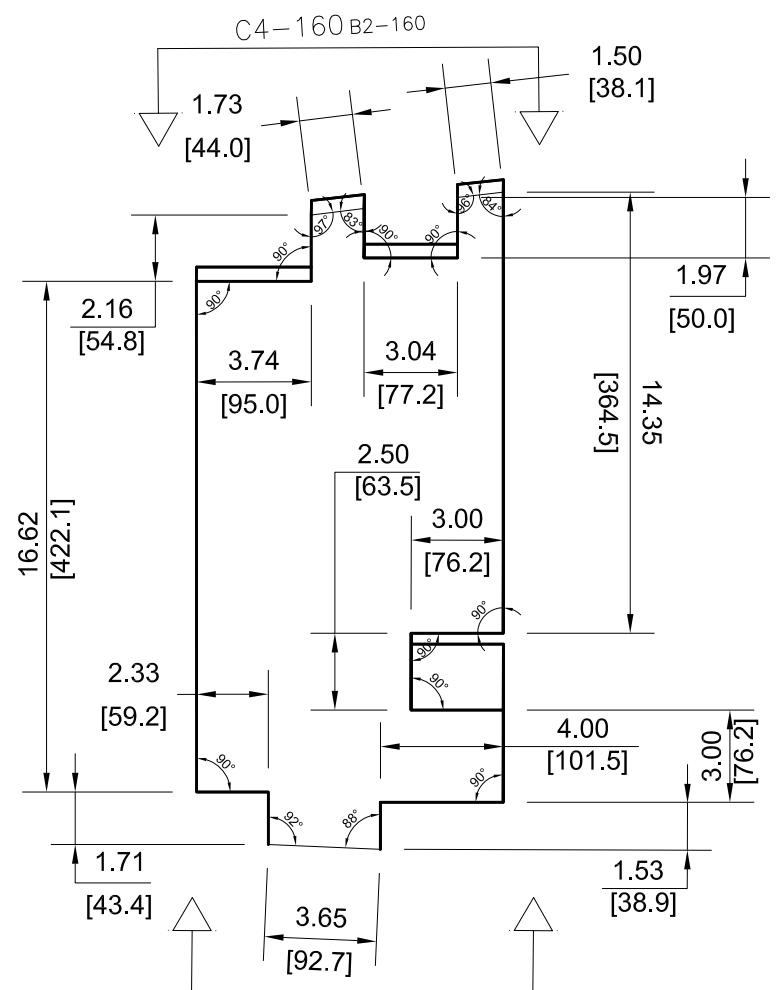

VIEW D7-160

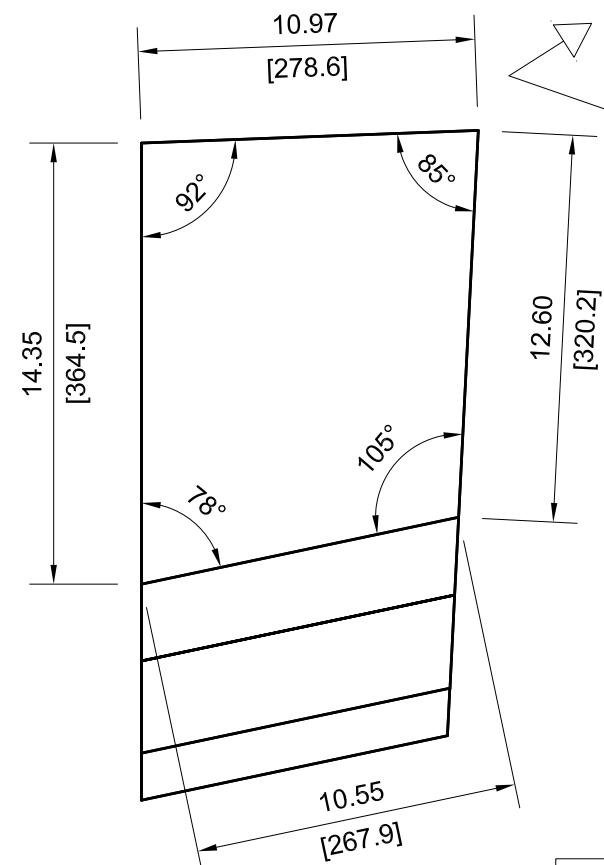

VIEW D8-160

NOTE: ALL VIEWS TAKEN AS TRUE VIEWS PARALLEL TO SURFACE OF PART

DRAWING NUMBER		AES-D0002		
SIZE	SCALE	SHEET	OF	REVISION
A3	NONE	160	167	F

- 385

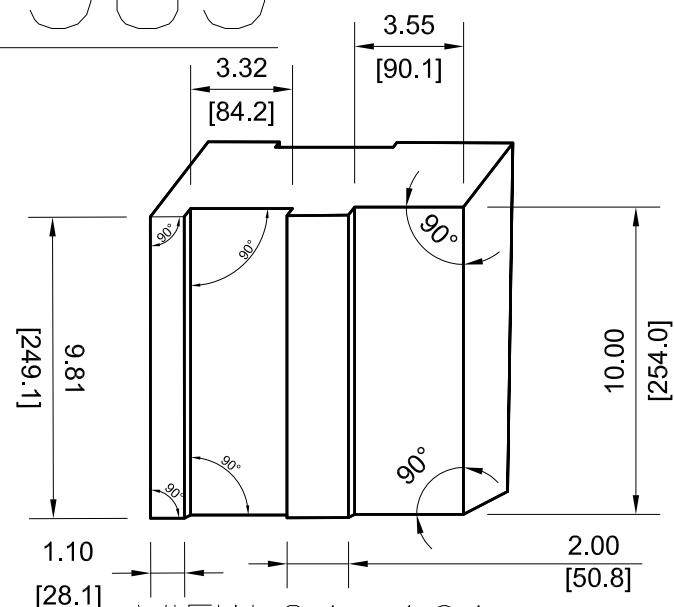

VIEW C4-161

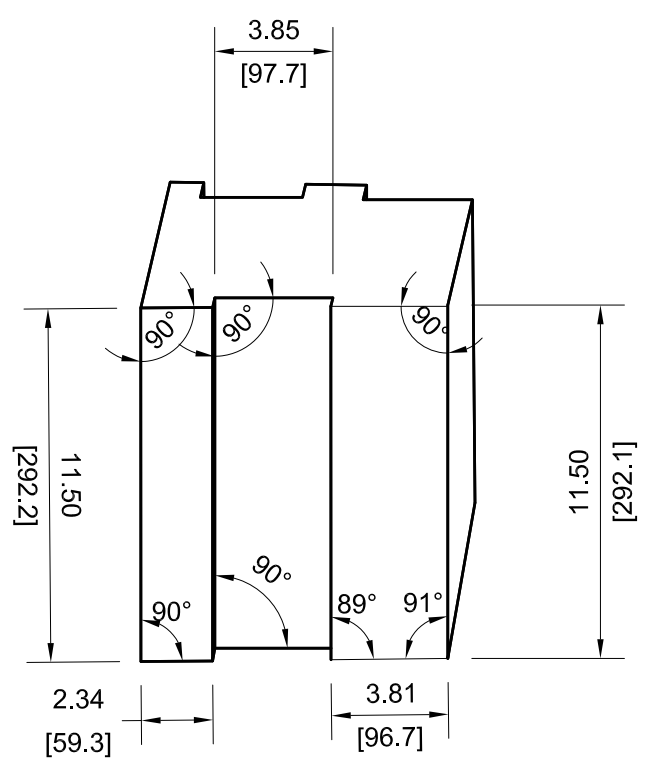

VIEW F4-161

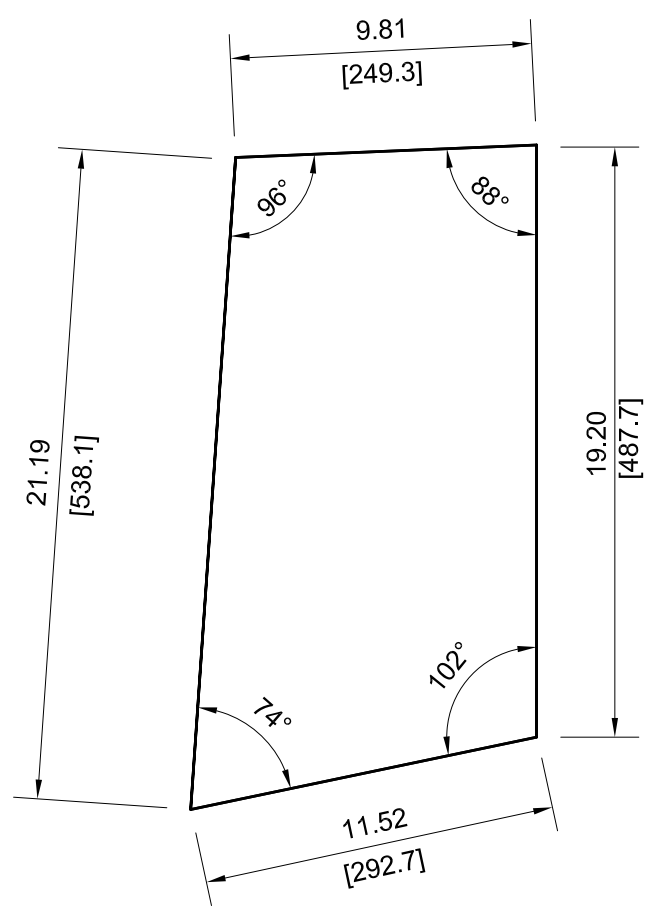
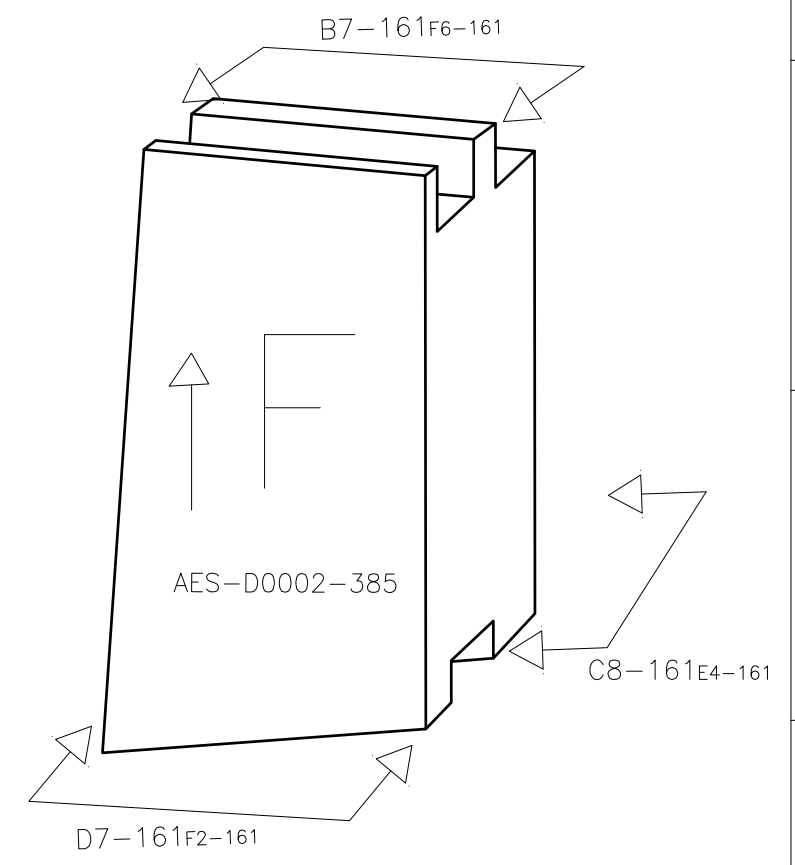

VIEW D7-161

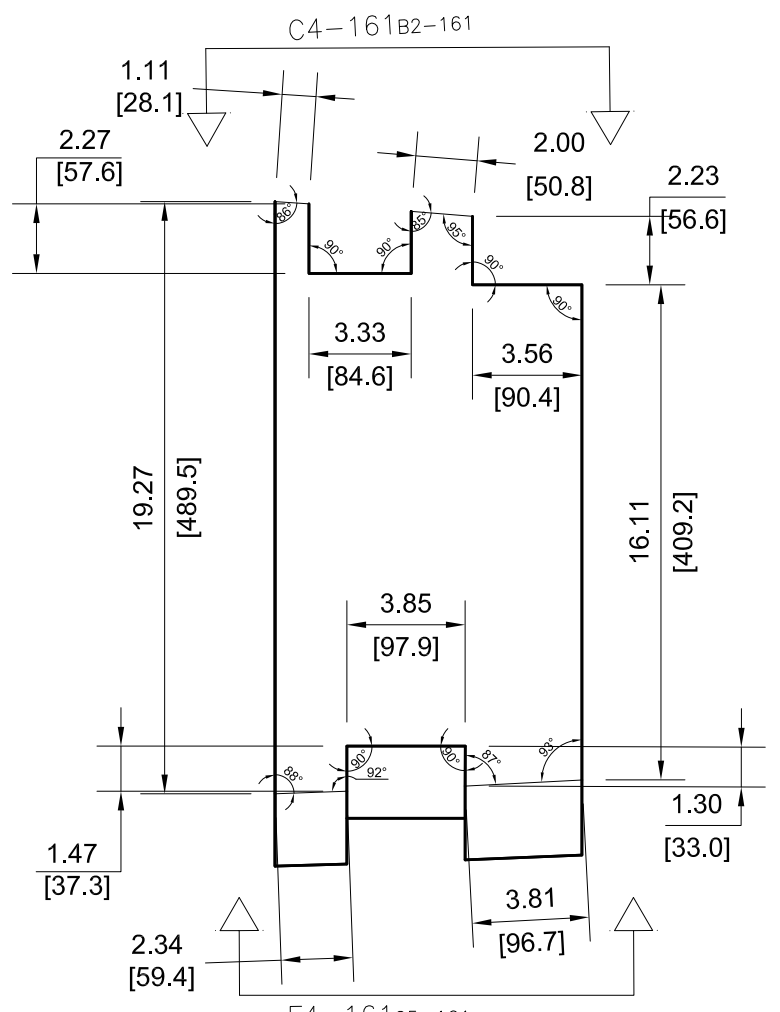

VIEW C8-161

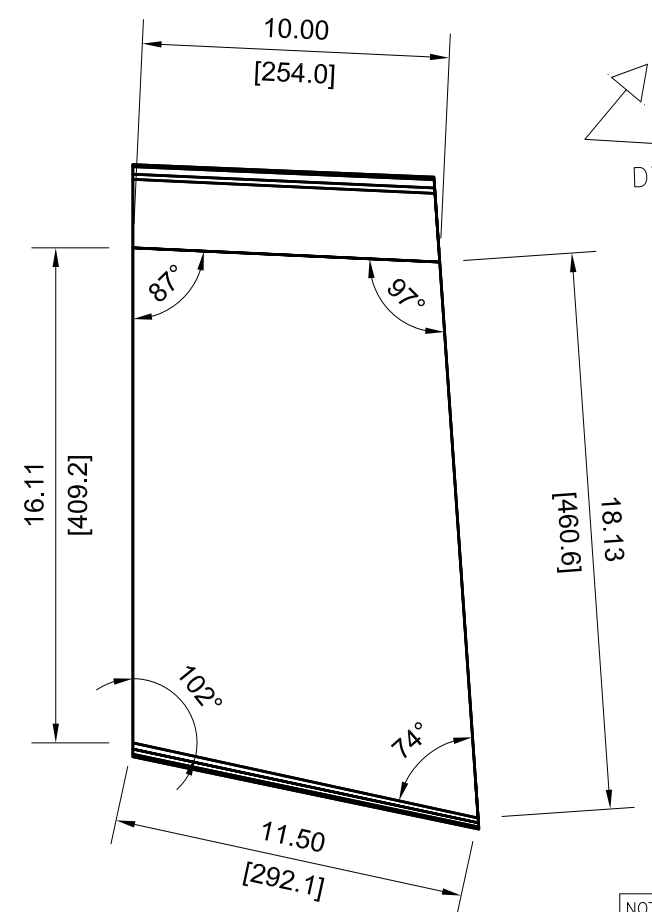

VIEW B7-161

NOTE: ALL VIEWS TAKEN AS TRUE VIEWS PARALLEL TO SURFACE OF PART

		DRAWING NUMBER			
		AES-D0002			
SIZE	SCALE	SHEET	OF	REVISION	
A3	NONE	161	167	F	

-387

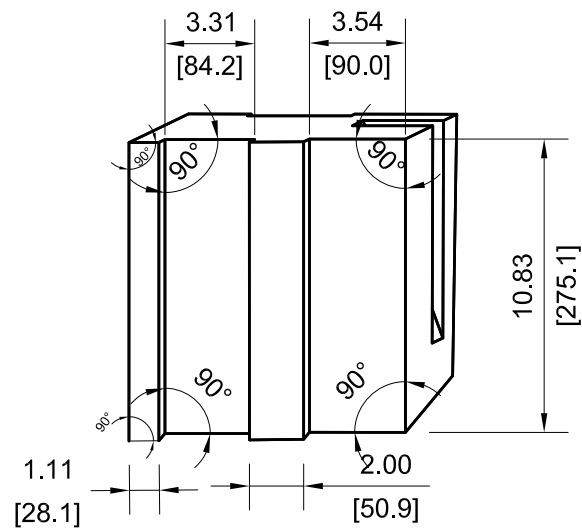

VIEW C4-162

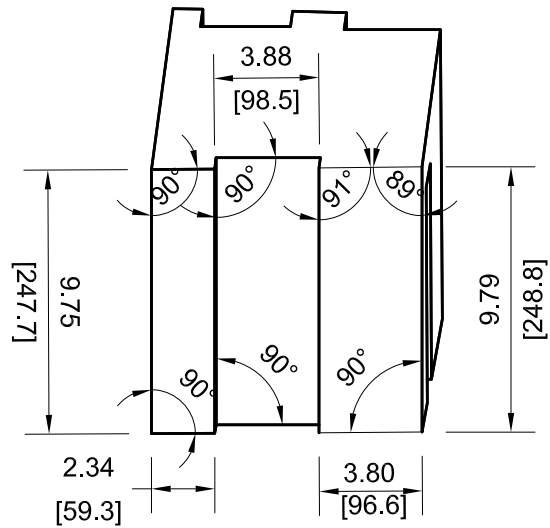

VIEW F4-162

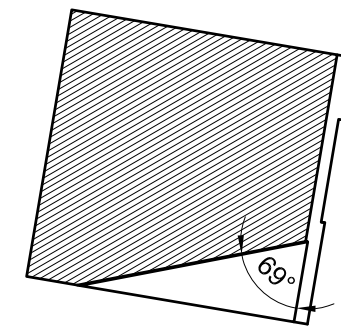

SECTION VIEW E6-162

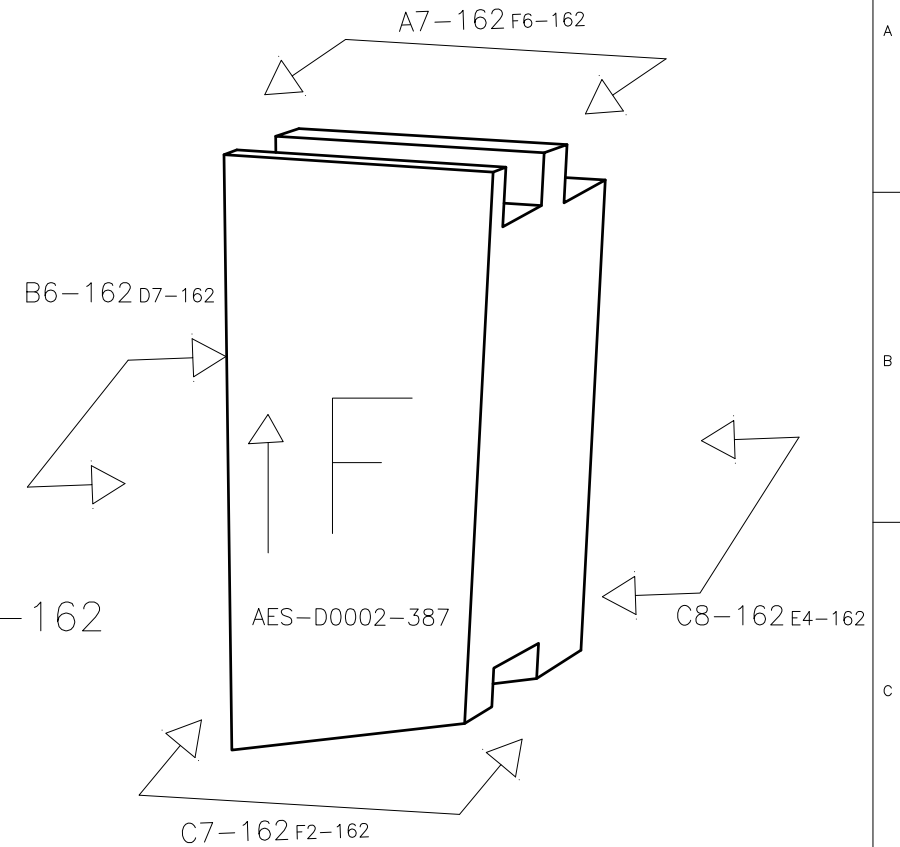

VIEW B6-162

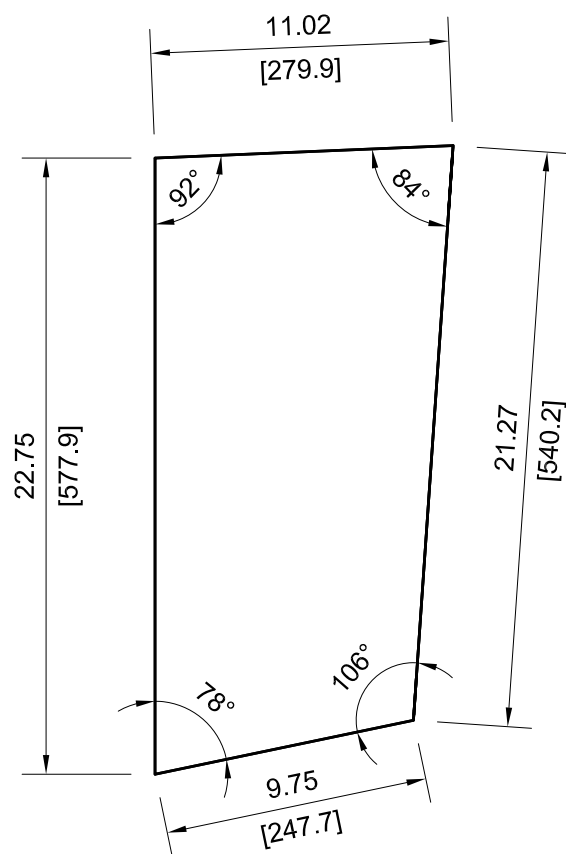

VIEW C7-162

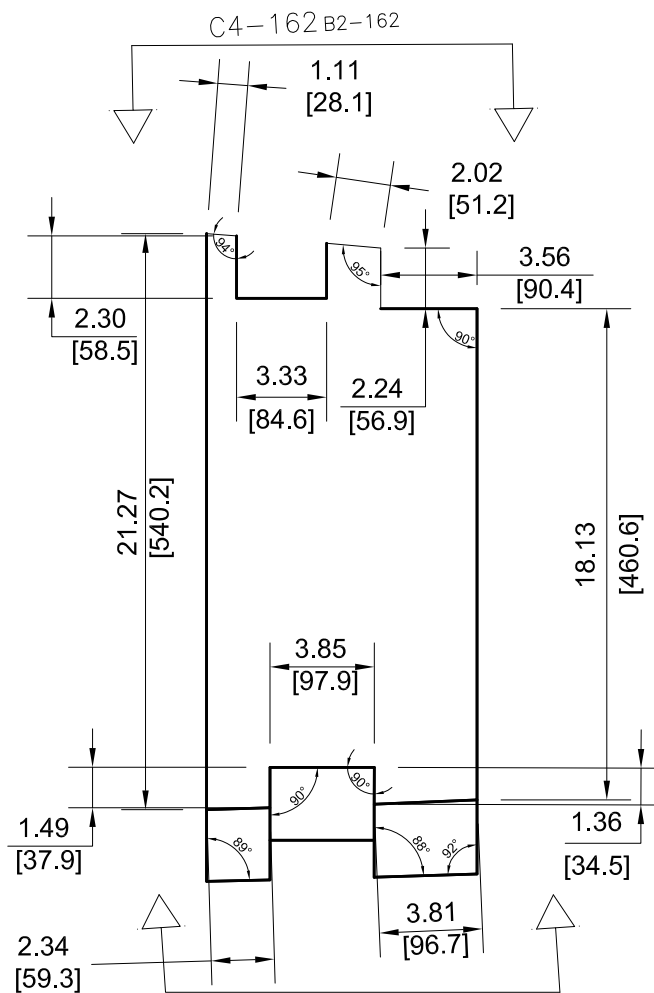

VIEW C8-162

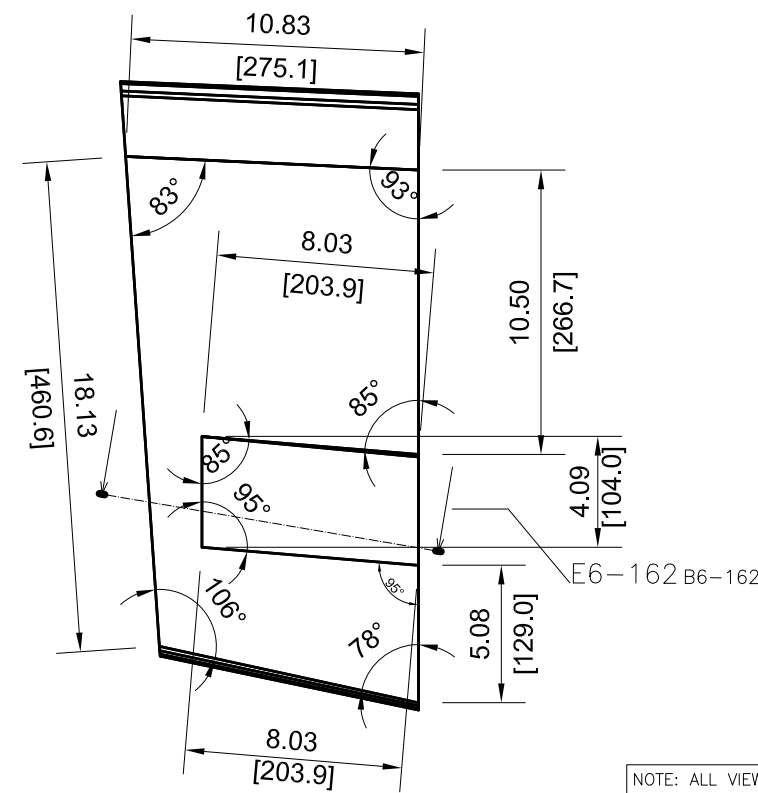

VIEW A7-162

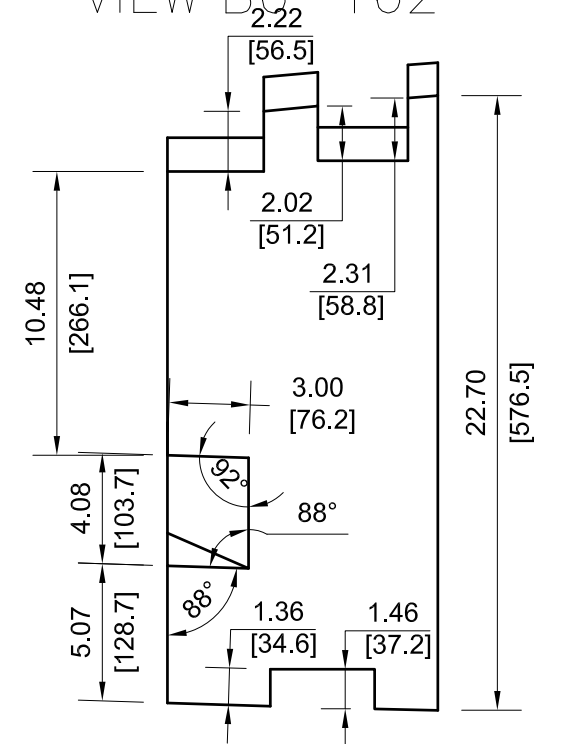

NOTE: ALL VIEWS TAKEN AS TRUE VIEWS PARALLEL TO SURFACE OF PART

		DRAWING NUMBER			
		AES-D0002			
SIZE	SCALE	SHEET	OF	REVISION	
A3	NONE	162	167	F	

— 389 FWD

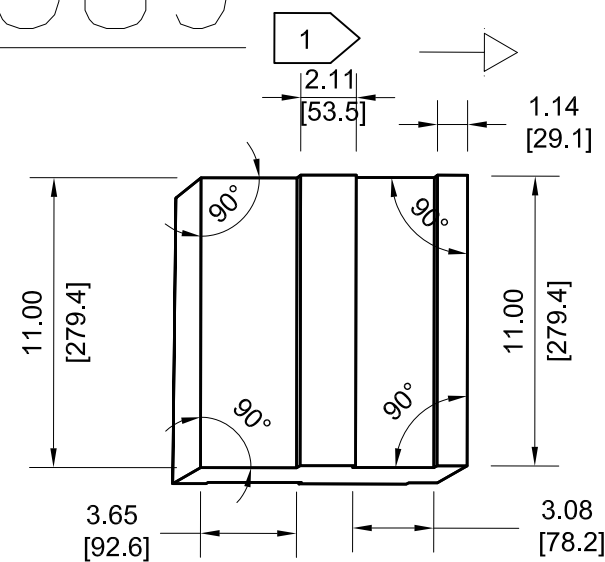

VIEW C4-163

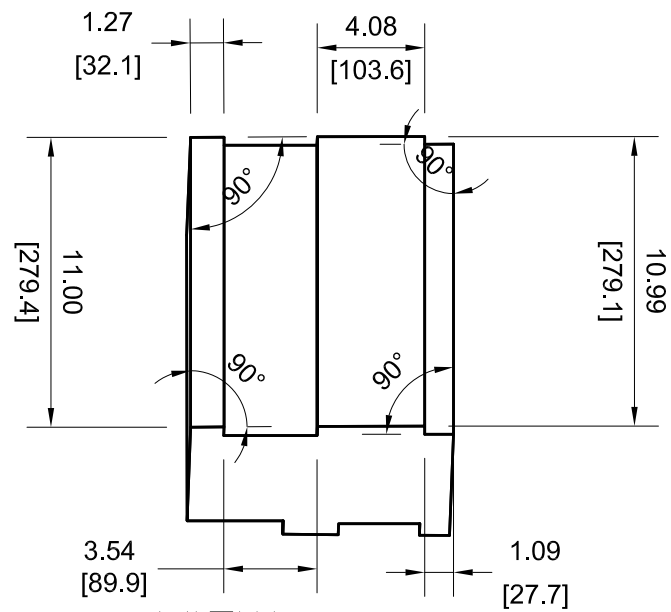

VIEW F4-163

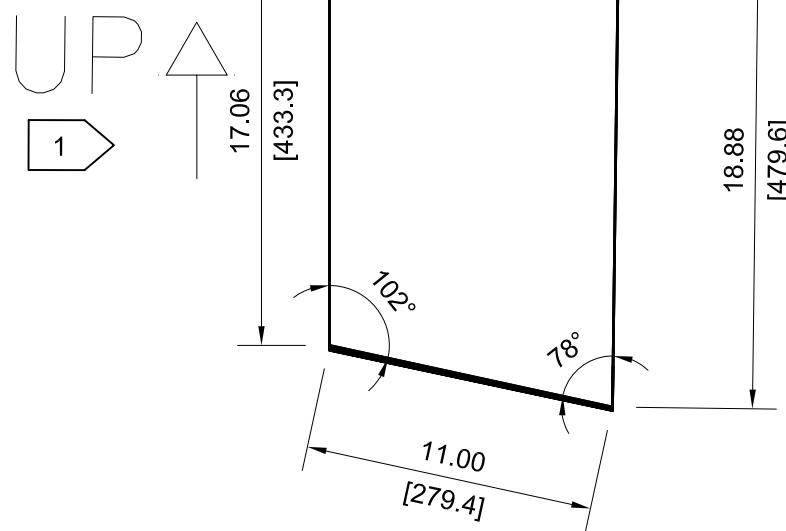
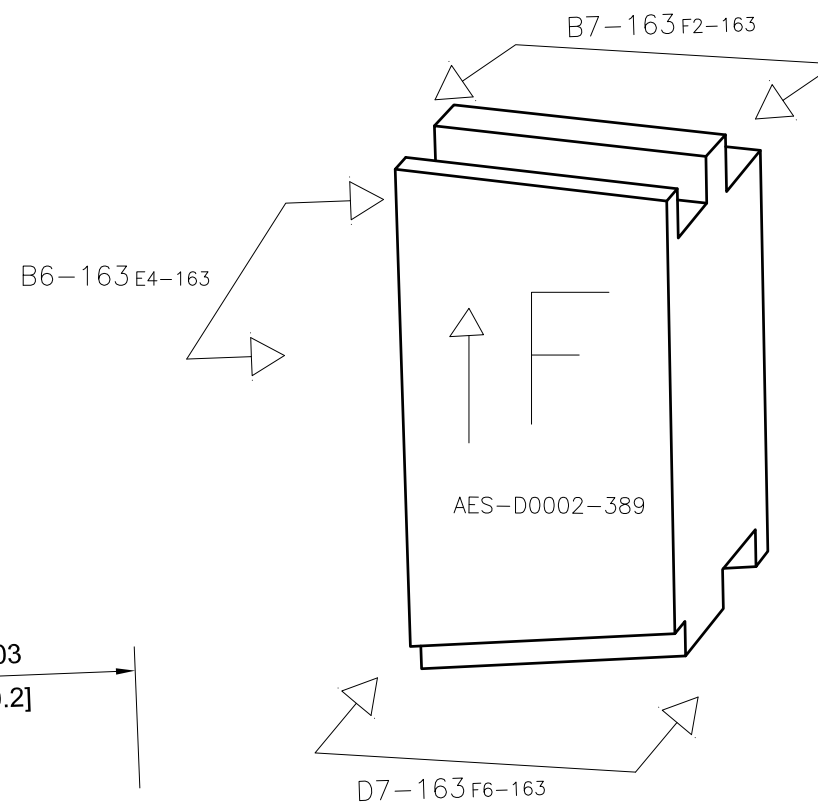

VIEW B7-163

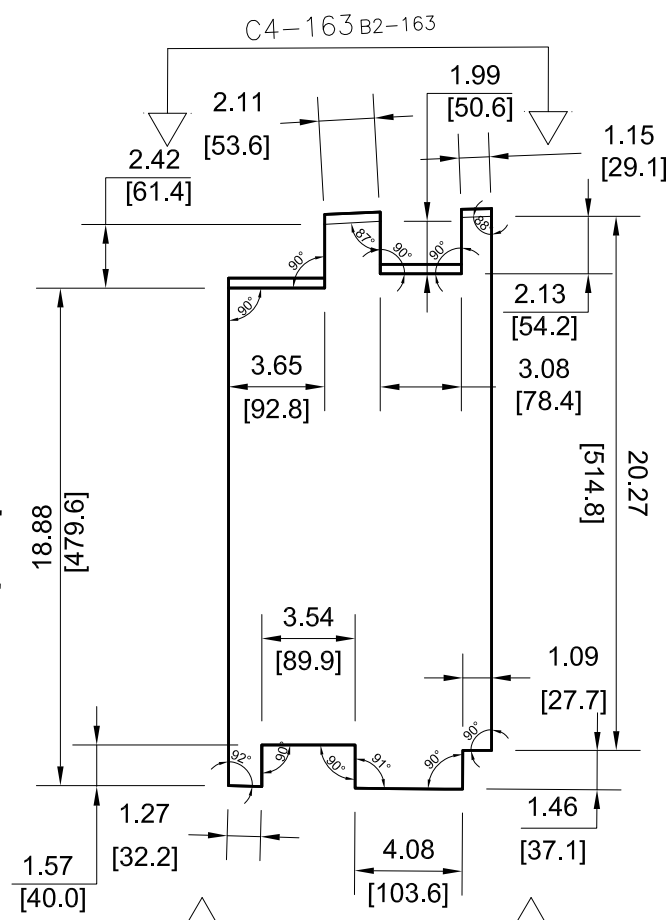

VIEW B6-163

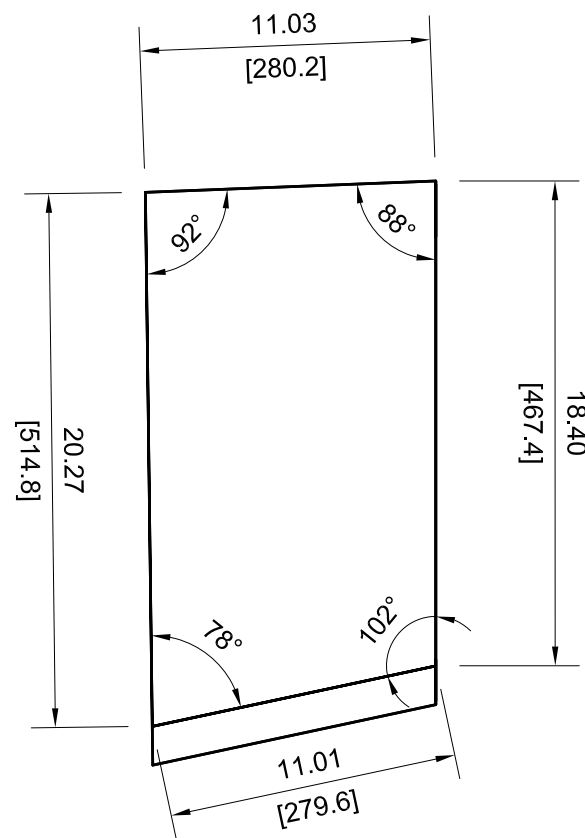

VIEW D7-163

NOTE: ALL VIEWS TAKEN AS TRUE VIEWS PARALLEL TO SURFACE OF PART

		DRAWING NUMBER			
		AES-D0002			
SIZE	SCALE	SHEET	OF	REVISION	
A3	NONE	163	167	F	

-391

FWD

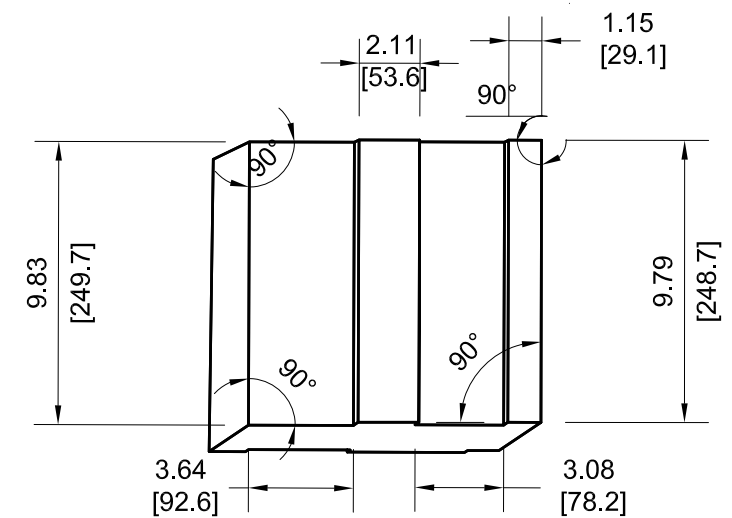

VIEW C4-164

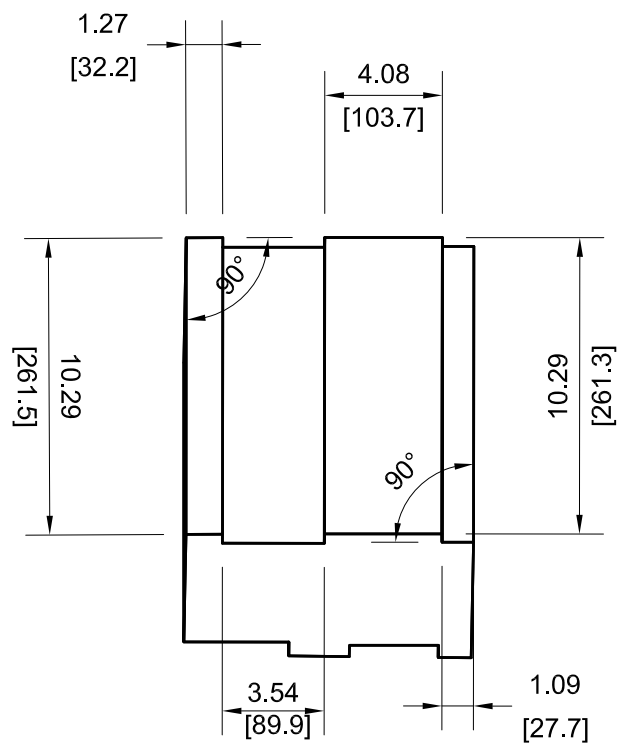

VIEW F4-164

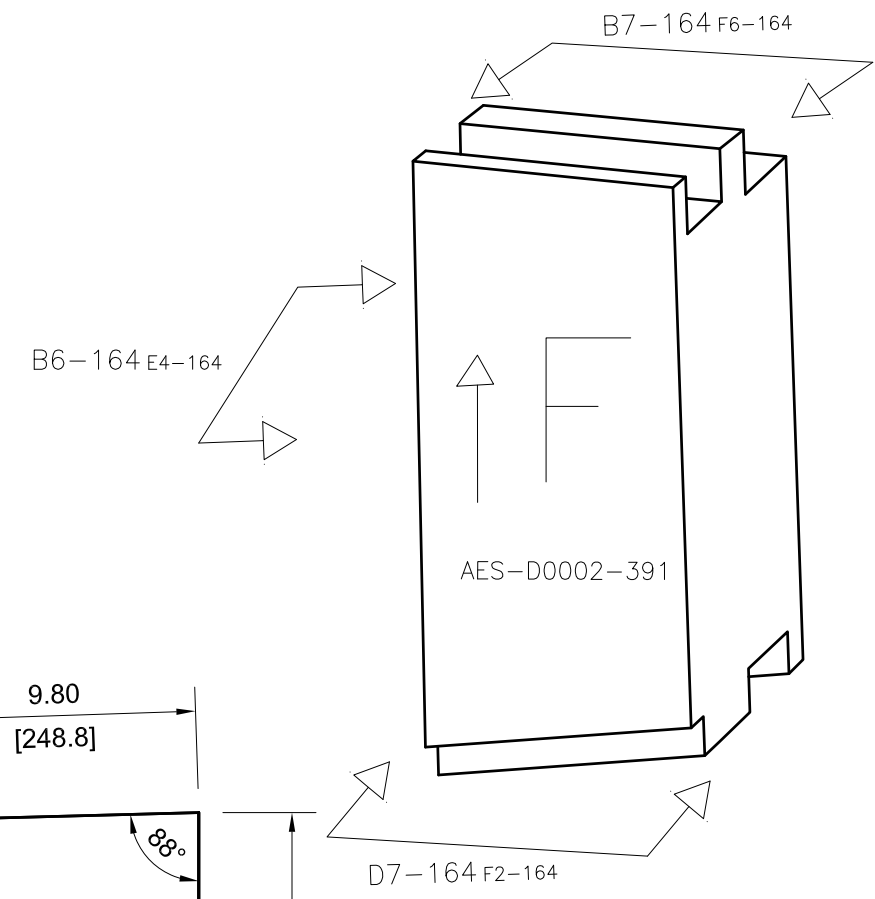

UP

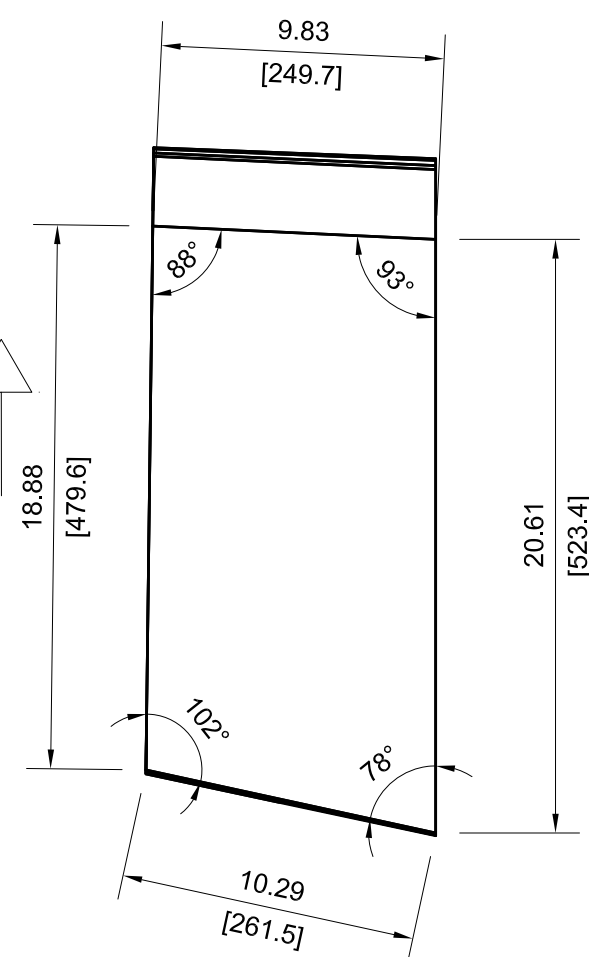

VIEW B7-164

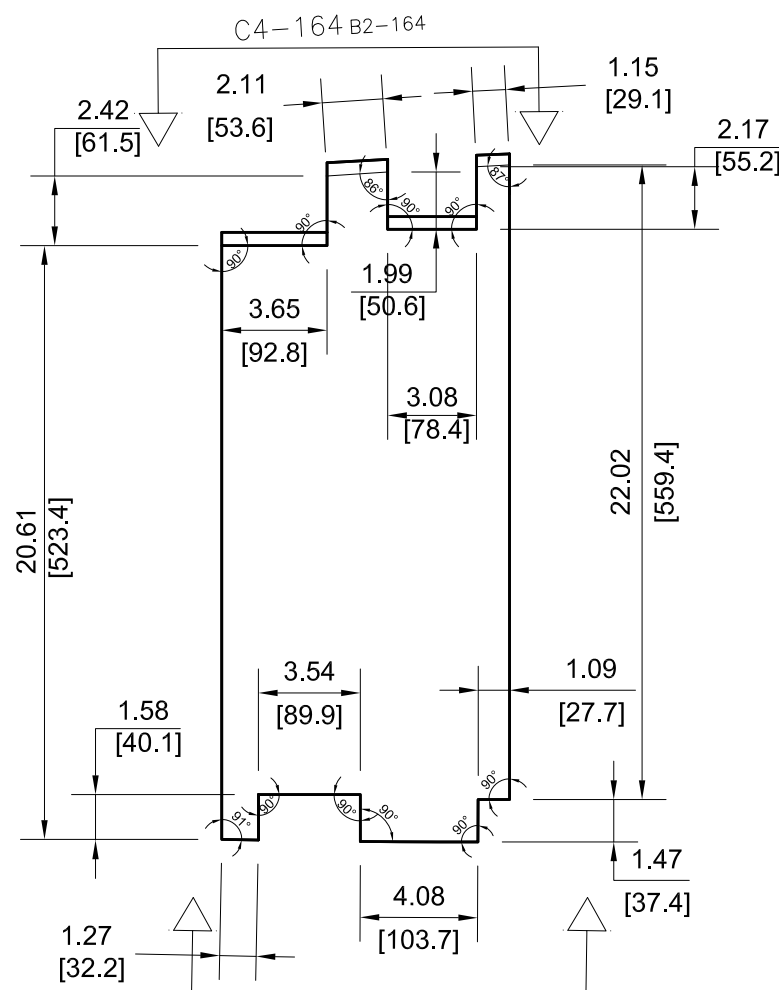

VIEW B6-164

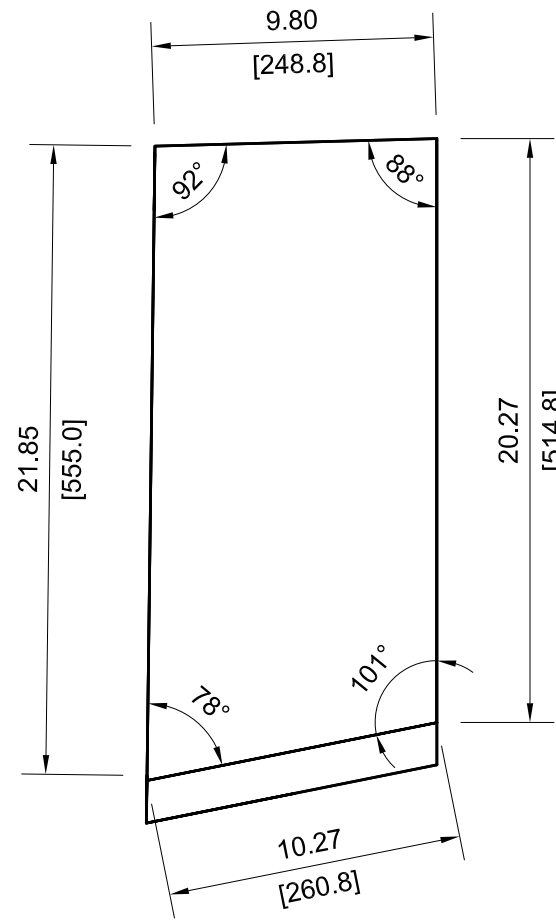

VIEW D7-164

NOTE: ALL VIEWS TAKEN AS TRUE VIEWS PARALLEL TO SURFACE OF PART

		DRAWING NUMBER			
		AES-D0002			
SIZE	SCALE	SHEET	OF	REVISION	
A3	NONE	164	167	F	

-393

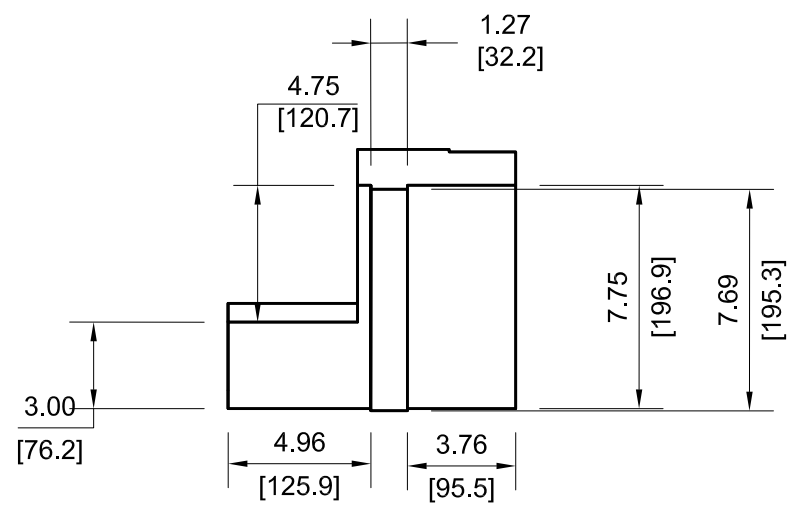

VIEW C4-165

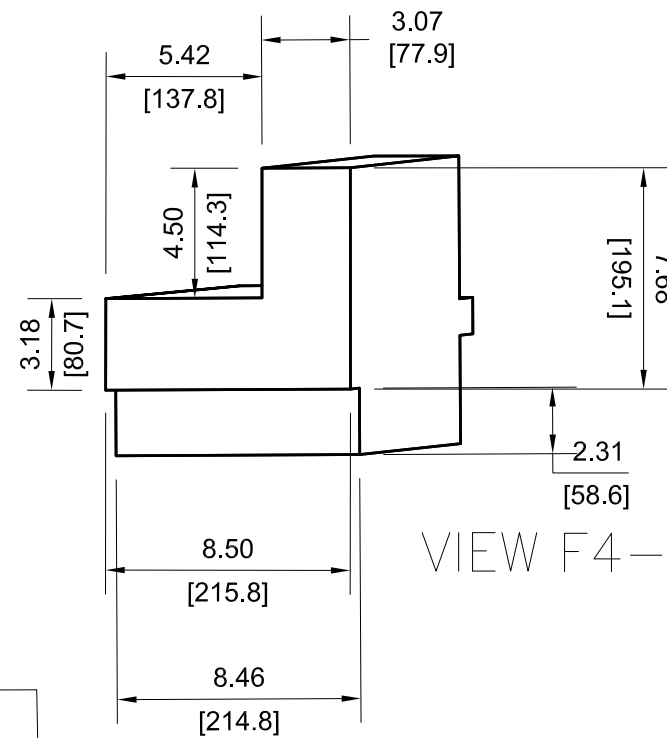

VIEW F4-165

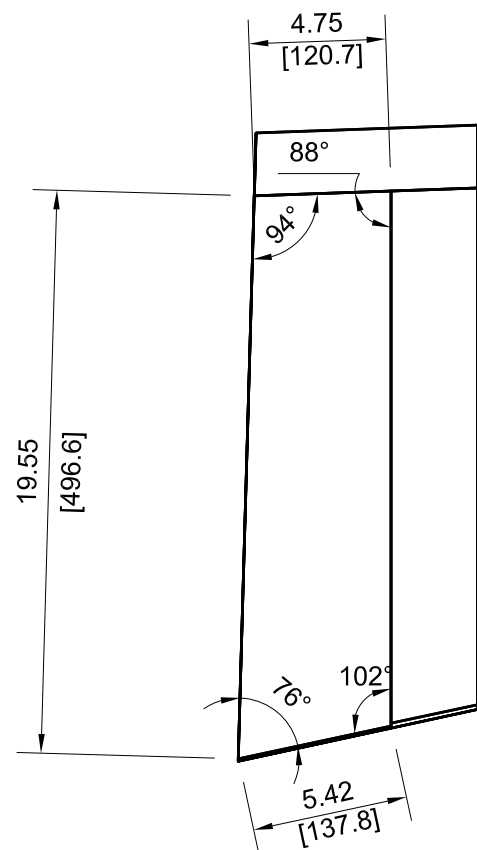
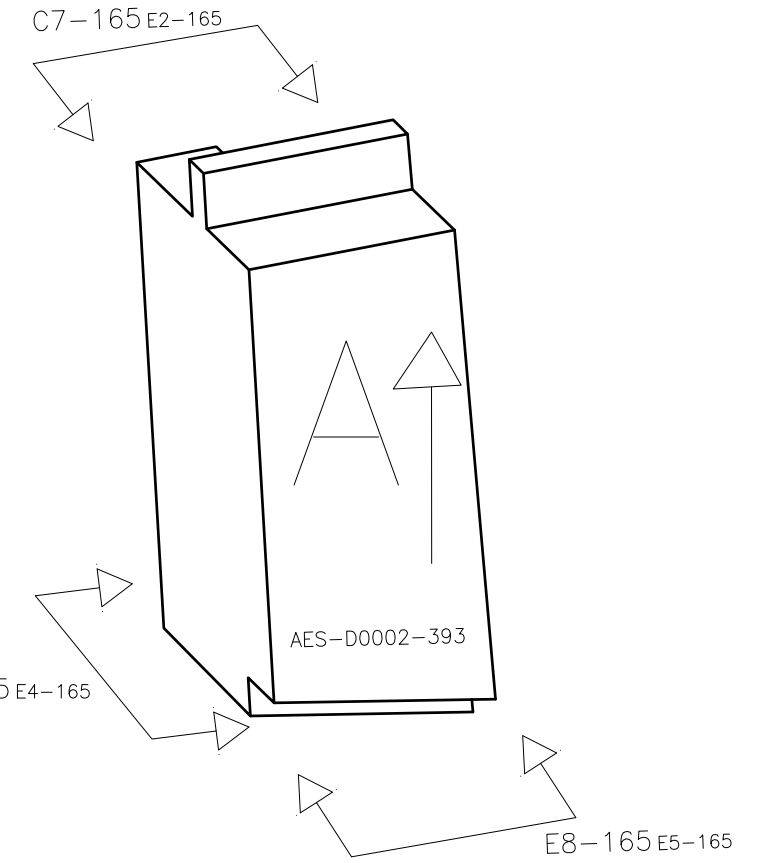

VIEW C7-165

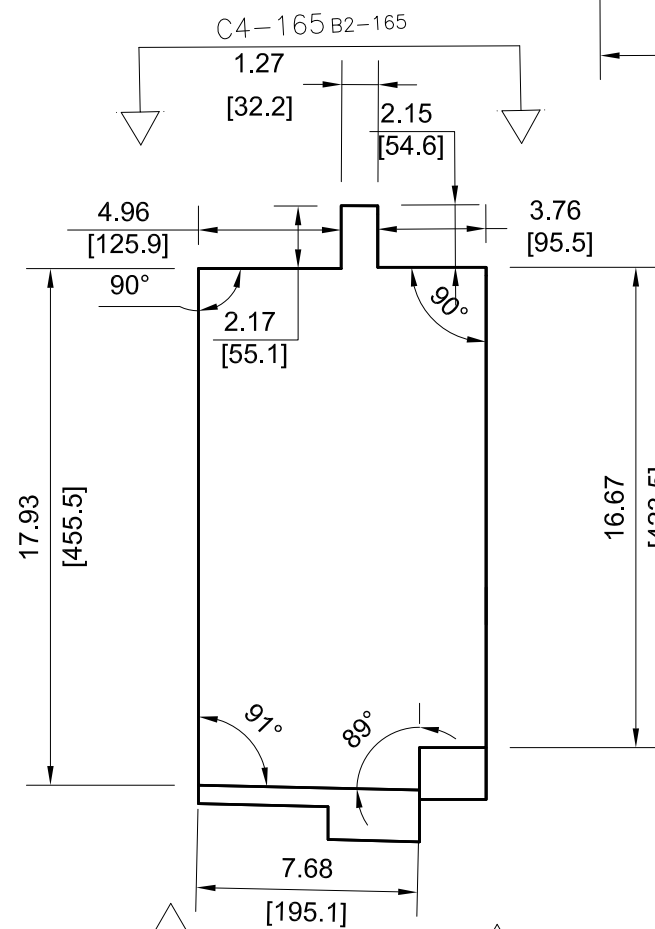

VIEW E7-165

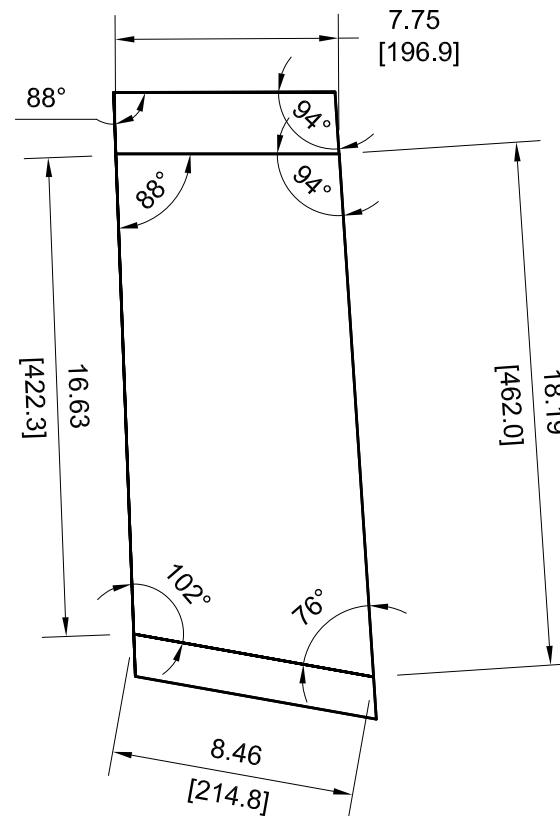

VIEW E8-165

NOTE: ALL VIEWS TAKEN AS TRUE VIEWS PARALLEL TO SURFACE OF PART

		DRAWING NUMBER			
		AES-D0002			
SIZE	SCALE	SHEET	OF	REVISION	
A3	NONE	165	167	F	

-395

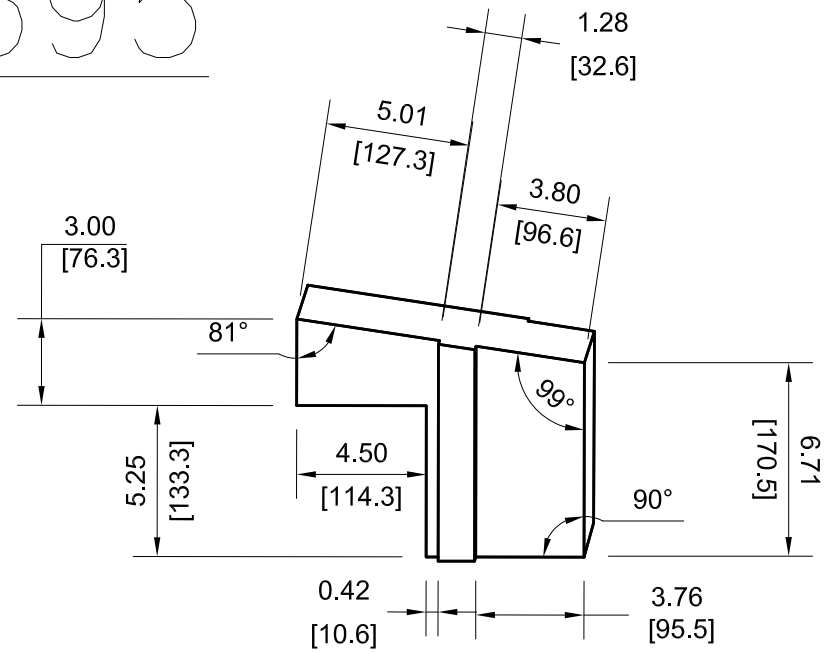

VIEW C4-166

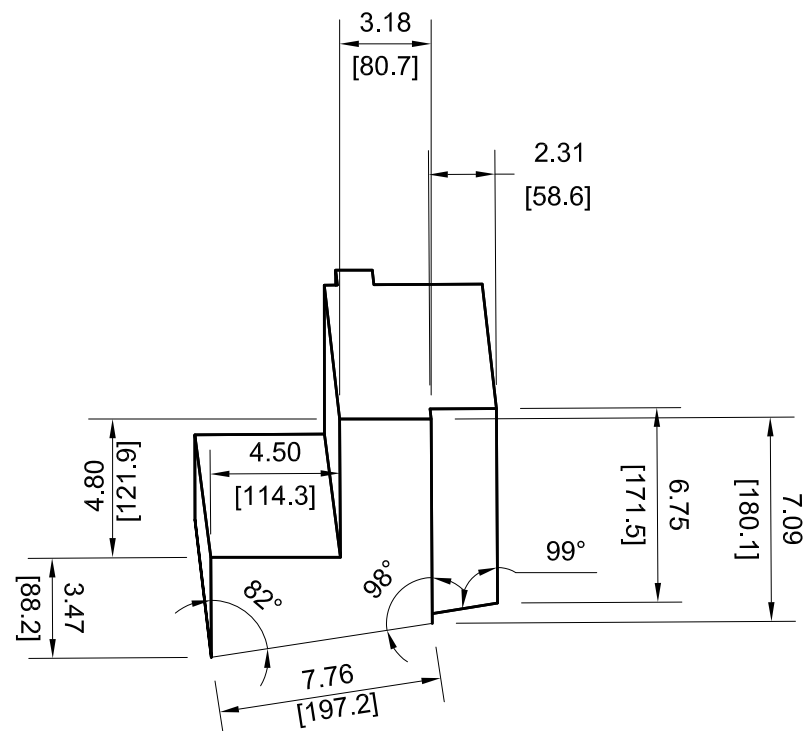

VIEW F4-166

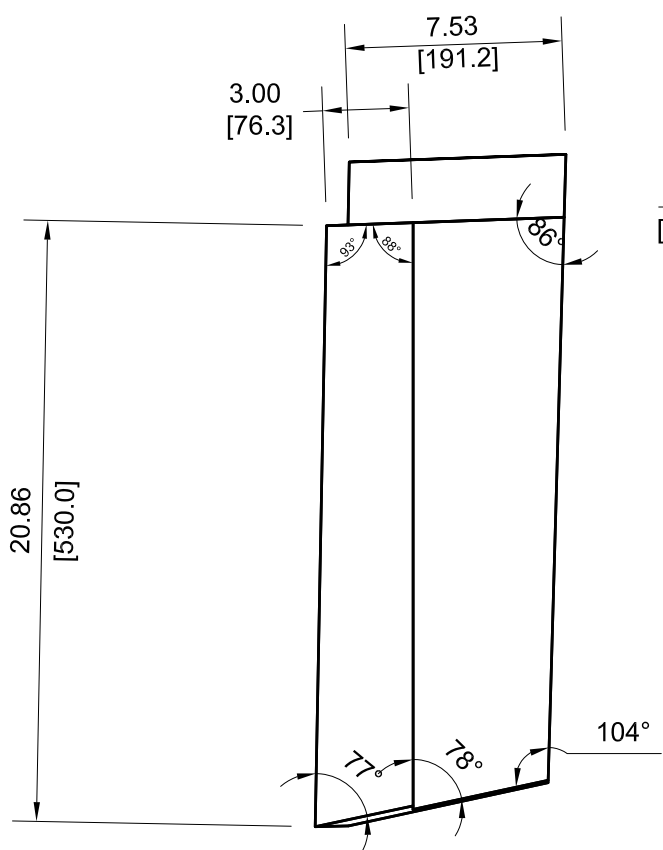

VIEW C7-166

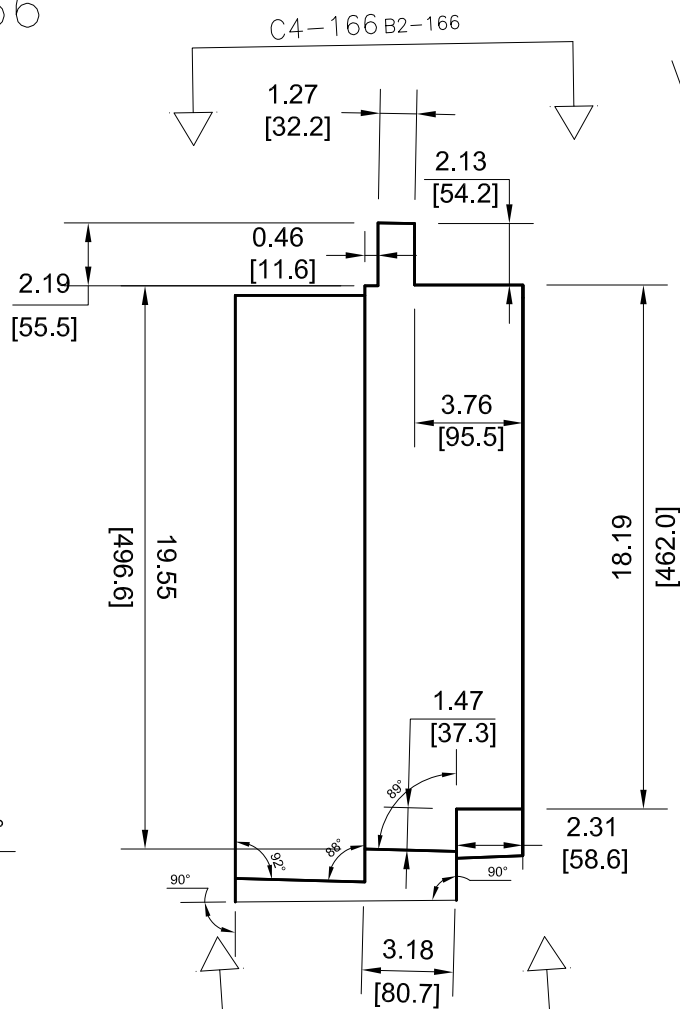

VIEW E7-166

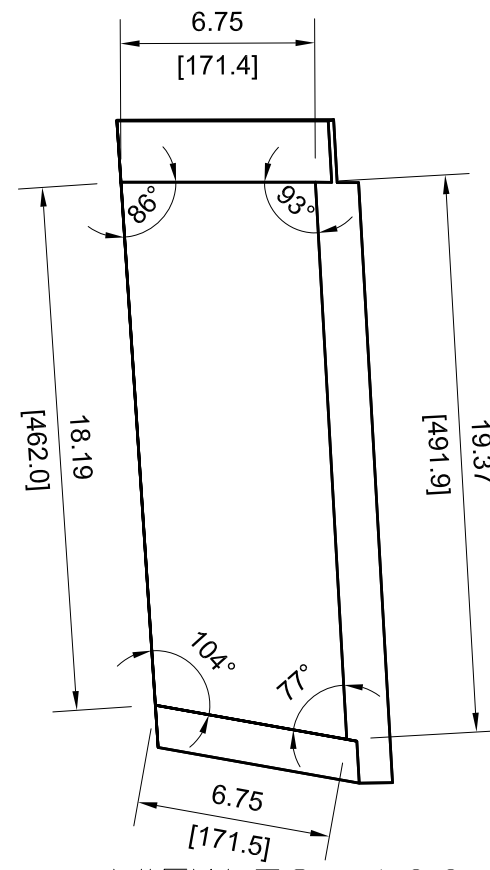

VIEW E8-166

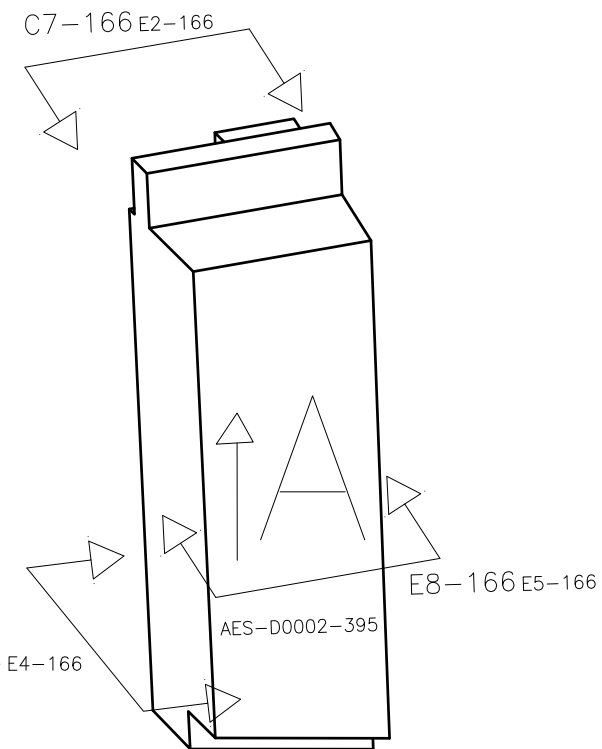

E8-166 E5-166

NOTE: ALL VIEWS TAKEN AS TRUE VIEWS PARALLEL TO SURFACE OF PART

	DRAWING NUMBER				AES-D0002
	SIZE	SCALE	SHEET	OF	REVISION
A3	NONE	166	167	F	

-397

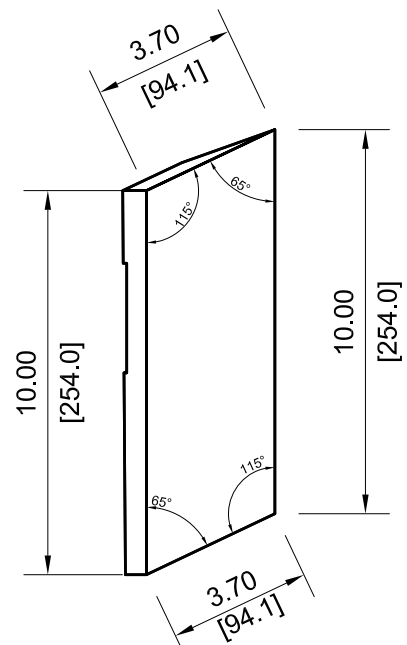

VIEW D3-167

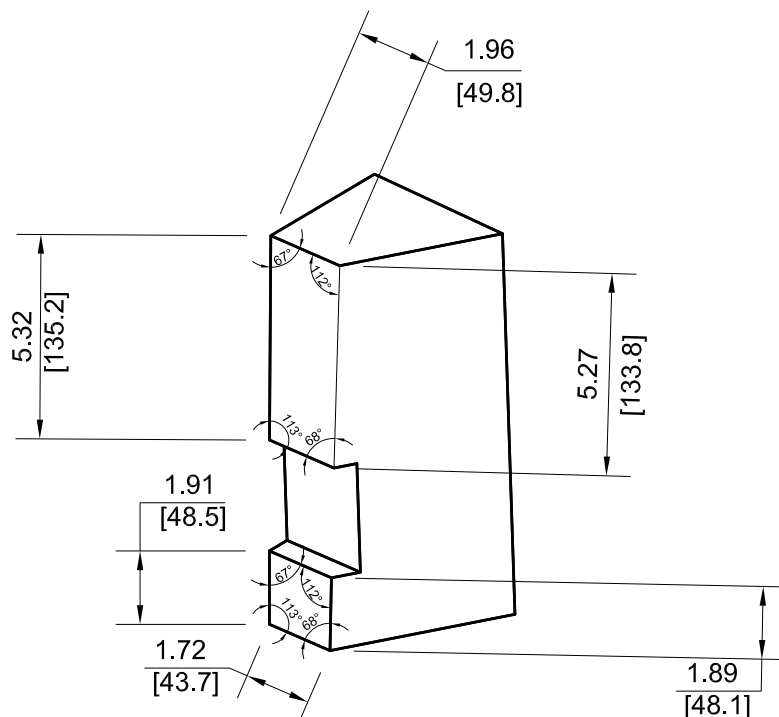

VIEW F3-167

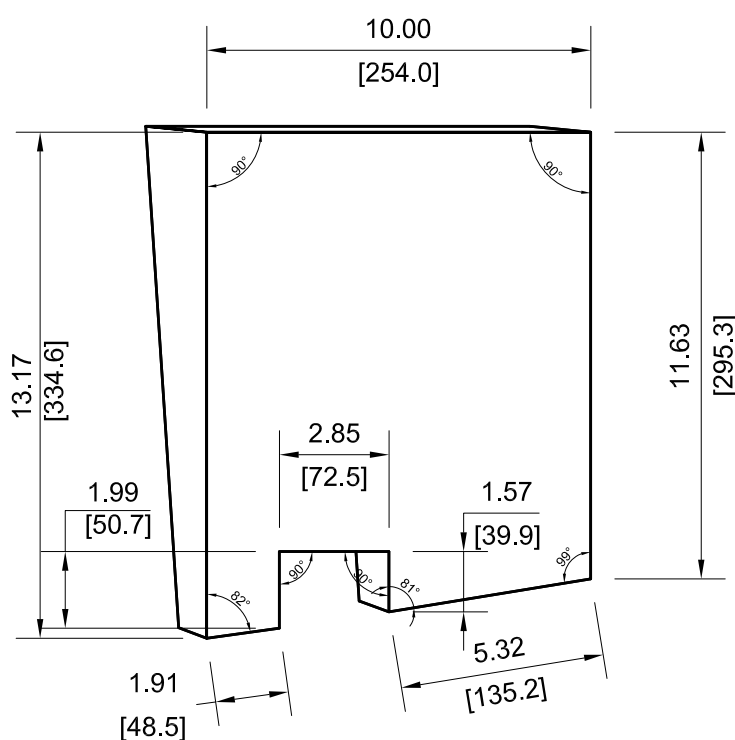

VIEW E8-167

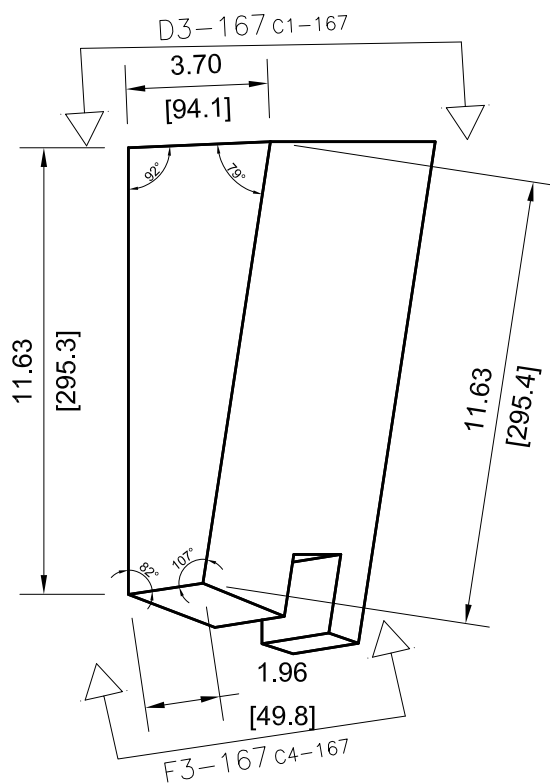

VIEW D8-167

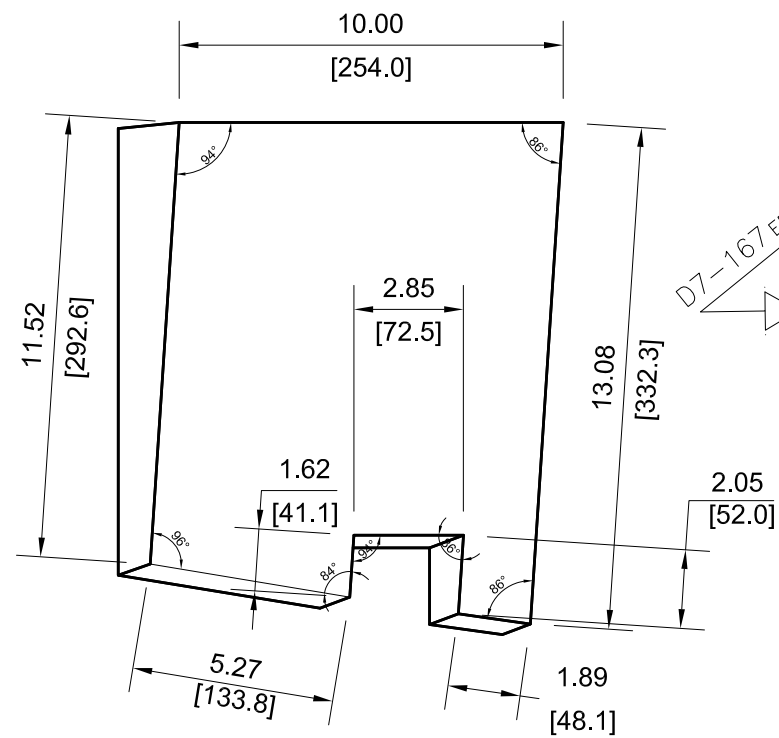

VIEW D7-167

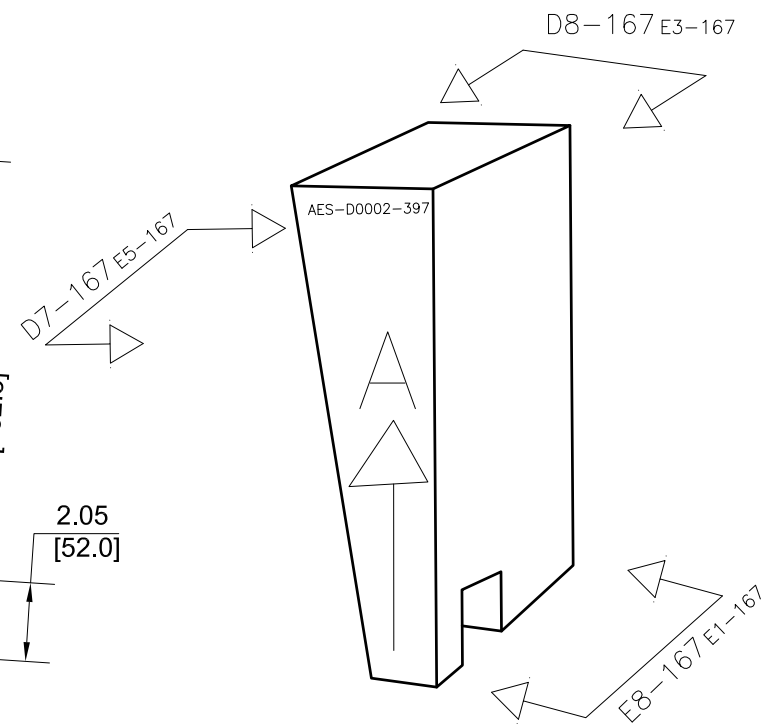

NOTE: ALL VIEWS TAKEN AS TRUE VIEWS PARALLEL TO SURFACE OF PART

		DRAWING NUMBER			
		AES-D0002			
SIZE	SCALE	SHEET	OF	REVISION	
A3	NONE	167	167	F	