

REVISIONS		
REV	DESCRIPTION	DATE
-	INITIAL REVISION	13-MAR-2017
A	ADDED ADDITIONAL DIMENSIONS FOR EASE OF INSPECTION. PARTS -352 AND -360 REVISED TO CORRECT DRAFTING ERRORS.	4-APRIL-2017
B	PARTS -2, -4, -6, -8, -12, -14, -16, -18, -38, -48, -50, -52, -54, -56, -58, -60, -62, -64, -66, -68, -70, -72, -74, -86, -88, -90, -92, -94, -96, -128, -130, -132, -138, -140, -142, -144, -146, -148, -150, -156, -158, 168, -170, -176, -180, -182, -186, -188, -196, -198, -206, -208, -220, -222, -234, -246, -262, -272, -280, -290, -302, -304, -306, -310, -312, -348, -350, -352, -354, -356 & -358 UPDATED. PART -166 AND -178 MADE OBSOLETE. GN 11 UPDATED.	14-JAN-2018

INDEX																							
SHEET	REV	DESCRIPTION	NHA	SHEET	REV	DESCRIPTION	NHA	SHEET	REV	DESCRIPTION	NHA	SHEET	REV	DESCRIPTION	NHA	SHEET	REV	DESCRIPTION	NHA	SHEET	REV	DESCRIPTION	NHA
0	-	INDEX	-	32	-	DETAIL -60	-	64	-	DETAIL -124	-	96	-	DETAIL -188	-	128	-	DETAIL -252	-	160	-	DETAIL -316	-
1	-	PARTS LIST	-	33	-	DETAIL -62	-	65	-	DETAIL -126	-	97	-	DETAIL -190	-	129	-	DETAIL -254	-	161	-	DETAIL -318	-
2	-	NOTES	-	34	-	DETAIL -64	-	66	-	DETAIL -128	-	98	-	DETAIL -192	-	130	-	DETAIL -256	-	162	-	DETAIL -320	-
3	-	DETAIL -2	-	35	-	DETAIL -66	-	67	-	DETAIL -130	-	99	-	DETAIL -194	-	131	-	DETAIL -258	-	163	-	DETAIL -322	-
4	-	DETAIL -4	-	36	-	DETAIL -68	-	68	-	DETAIL -132	-	100	-	DETAIL -196	-	132	-	DETAIL -260	-	164	-	DETAIL -324	-
5	-	DETAIL -6	-	37	-	DETAIL -70	-	69	-	DETAIL -134	-	101	-	DETAIL -198	-	133	-	DETAIL -262	-	165	-	DETAIL -326	-
6	-	DETAIL -8	-	38	-	DETAIL -72	-	70	-	DETAIL -136	-	102	-	DETAIL -200	-	134	-	DETAIL -264	-	166	-	DETAIL -328	-
7	-	DETAIL -10	-	39	-	DETAIL -74	-	71	-	DETAIL -138	-	103	-	DETAIL -202	-	135	-	DETAIL -266	-	167	-	DETAIL -330	-
8	-	DETAIL -12	-	40	-	DETAIL -76	-	72	-	DETAIL -140	-	104	-	DETAIL -204	-	136	-	DETAIL -268	-	168	-	DETAIL -332	-
9	-	DETAIL -14	-	41	-	DETAIL -78	-	73	-	DETAIL -142	-	105	-	DETAIL -206	-	137	-	DETAIL -270	-	169	-	DETAIL -334	-
10	-	DETAIL -16	-	42	-	DETAIL -80	-	74	-	DETAIL -144	-	106	-	DETAIL -208	-	138	-	DETAIL -272	-	170	-	DETAIL -336	-
11	-	DETAIL -18	-	43	-	DETAIL -82	-	75	-	DETAIL -146	-	107	-	DETAIL -210	-	139	-	DETAIL -274	-	171	-	DETAIL -338	-
12	-	DETAIL -20	-	44	-	DETAIL -84	-	76	-	DETAIL -148	-	108	-	DETAIL -212	-	140	-	DETAIL -276	-	172	-	DETAIL -340	-
13	-	DETAIL -22	-	45	-	DETAIL -86	-	77	-	DETAIL -150	-	109	-	DETAIL -214	-	141	-	DETAIL -278	-	173	-	DETAIL -342	-
14	-	DETAIL -24	-	46	-	DETAIL -88	-	78	-	DETAIL -152	-	110	-	DETAIL -216	-	142	-	DETAIL -280	-	174	-	DETAIL -344	-
15	-	DETAIL -26	-	47	-	DETAIL -90	-	79	-	DETAIL -154	-	111	-	DETAIL -218	-	143	-	DETAIL -282	-	175	-	DETAIL -346	-
16	-	DETAIL -28	-	48	-	DETAIL -92	-	80	-	DETAIL -156	-	112	-	DETAIL -220	-	144	-	DETAIL -284	-	176	-	DETAIL -348	-
17	-	DETAIL -30	-	49	-	DETAIL -94	-	81	-	DETAIL -158	-	113	-	DETAIL -222	-	145	-	DETAIL -286	-	177	-	DETAIL -350	-
18	-	DETAIL -32	-	50	-	DETAIL -96	-	82	-	DETAIL -160	-	114	-	DETAIL -224	-	146	-	DETAIL -288	-	178	-	DETAIL -352	-
19	-	DETAIL -34	-	51	-	DETAIL -98	-	83	-	DETAIL -162	-	115	-	DETAIL -226	-	147	-	DETAIL -290	-	179	-	DETAIL -354	-
20	-	DETAIL -36	-	52	-	DETAIL -100	-	84	-	DETAIL -164	-	116	-	DETAIL -228	-	148	-	DETAIL -292	-	180	-	DETAIL -356	-
21	-	DETAIL -38	-	53	-	DETAIL -102	-	85	-	DETAIL -166	-	117	-	DETAIL -230	-	149	-	DETAIL -294	-	181	-	DETAIL -358	-
22	-	DETAIL -40	-	54	-	DETAIL -104	-	86	-	DETAIL -168	-	118	-	DETAIL -232	-	150	-	DETAIL -296	-	182	-	DETAIL -360	-
23	-	DETAIL -42	-	55	-	DETAIL -106	-	87	-	DETAIL -170	-	119	-	DETAIL -234	-	151	-	DETAIL -298	-	183	-	DETAIL -362	-
24	-	DETAIL -44	-	56	-	DETAIL -108	-	88	-	DETAIL -172	-	120	-	DETAIL -236	-	152	-	DETAIL -300	-	184	-	DETAIL -364	-
25	-	DETAIL -46	-	57	-	DETAIL -110	-	89	-	DETAIL -174	-	121	-	DETAIL -238	-	153	-	DETAIL -302	-	185	-	DETAIL -366	-
26	-	DETAIL -48	-	58	-	DETAIL -112	-	90	-	DETAIL -176	-	122	-	DETAIL -240	-	154	-	DETAIL -304	-	186	-	DETAIL -368	-
27	-	DETAIL -50	-	59	-	DETAIL -114	-	91	-	DETAIL -178	-	123	-	DETAIL -242	-	155	-	DETAIL -306	-	187	-	DETAIL -370	-
28	-	DETAIL -52	-	60	-	DETAIL -116	-	92	-	DETAIL -180	-	124	-	DETAIL -244	-	156	-	DETAIL -308	-	188	-	DETAIL -372	-
29	-	DETAIL -54	-	61	-	DETAIL -118	-	93	-	DETAIL -182	-	125	-	DETAIL -246	-	157	-	DETAIL -310	-	189	-	DETAIL -374	-
30	-	DETAIL -56	-	62	-	DETAIL -120	-	94	-	DETAIL -184	-	126	-	DETAIL -248	-	158	-	DETAIL -312	-	190	-	DETAIL -376	-
31	-	DETAIL -58	-	63	-	DETAIL -122	-	95	-	DETAIL -186	-	127	-	DETAIL -250	-	159	-	DETAIL -314	-		-		-

UNLESS OTHERWISE SPECIFIED DIMENSIONS ARE IN INCHES [MM] TOLERANCES ARE:

.X ±.25 ±[6.35]	.XX ±.25 ±[6.35]	.XXX ±.25 ±[6.35]	ANGLE ±2'
-----------------------	------------------------	-------------------------	--------------

THIRD ANGLE PROJECTION

DO NOT SCALE DRAWING

THE INFORMATION CONTAINED HEREIN IS PROPRIETARY TO COMTECH AVIATION SERVICES AND SHALL NOT BE REPRODUCED OR DISCLOSED IN WHOLE OR IN PART OR USED FOR ANY DESIGN OR MANUFACTURE EXCEPT WHEN SUCH USER POSSESSES DIRECT, WRITTEN AUTHORIZATION FROM COMTECH AVIATION SERVICES.

CAD DRAWING NOT TO BE REVISED BY HAND

APPROVALS	DATE	APPROVALS	DATE
DRAWN A. CHONG 	14 JAN 2018	STRUCTURES N/A	
CHECKED F. WAHAB 	14 JAN 2018	SYSTEMS N/A	
INTERIORS N/A		APPROVED R. BLASCO 	14 JAN 2018

121 ALHAMBRA PLAZA
SUITE 1700, CORAL GABLES
FL 33134 USA
WWW.AERSALE.COM

DRAWING TITLE
FOAM BLOCK - RIGHT AUXILIARY SECTION 767

SIZE **A3** DRAWING NUMBER **AES-D0008** REV **B**

SCALE **NONE** DATASET **AES-D0008B** SHEET **0** OF **190**

47	AES-D0008-94	FOAM BLOCK	1
46	AES-D0008-92	FOAM BLOCK	1
45	AES-D0008-90	FOAM BLOCK	1
44	AES-D0008-88	FOAM BLOCK	1
43	AES-D0008-86	FOAM BLOCK	1
42	AES-D0008-84	FOAM BLOCK	1
41	AES-D0008-82	FOAM BLOCK	1
40	AES-D0008-80	FOAM BLOCK	1
39	AES-D0008-78	FOAM BLOCK	1
38	AES-D0008-76	FOAM BLOCK	1
37	AES-D0008-74	FOAM BLOCK	1
36	AES-D0008-72	FOAM BLOCK	1
35	AES-D0008-70	FOAM BLOCK	1
34	AES-D0008-68	FOAM BLOCK	1
33	AES-D0008-66	FOAM BLOCK	1
32	AES-D0008-64	FOAM BLOCK	1
31	AES-D0008-62	FOAM BLOCK	1
30	AES-D0008-60	FOAM BLOCK	1
29	AES-D0008-58	FOAM BLOCK	1
28	AES-D0008-56	FOAM BLOCK	1
27	AES-D0008-54	FOAM BLOCK	1
26	AES-D0008-52	FOAM BLOCK	1
25	AES-D0008-50	FOAM BLOCK	1
24	AES-D0008-48	FOAM BLOCK	1
23	AES-D0008-46	FOAM BLOCK	1
22	AES-D0008-44	FOAM BLOCK	1
21	AES-D0008-42	FOAM BLOCK	1
20	AES-D0008-40	FOAM BLOCK	1
19	AES-D0008-38	FOAM BLOCK	1
18	AES-D0008-36	FOAM BLOCK	1
17	AES-D0008-34	FOAM BLOCK	1
16	AES-D0008-32	FOAM BLOCK	1
15	AES-D0008-30	FOAM BLOCK	1
14	AES-D0008-28	FOAM BLOCK	1
13	AES-D0008-26	FOAM BLOCK	1
12	AES-D0008-24	FOAM BLOCK	1
11	AES-D0008-22	FOAM BLOCK	1
10	AES-D0008-20	FOAM BLOCK	1
9	AES-D0008-18	FOAM BLOCK	1
8	AES-D0008-16	FOAM BLOCK	1
7	AES-D0008-14	FOAM BLOCK	1
6	AES-D0008-12	FOAM BLOCK	1
5	AES-D0008-10	FOAM BLOCK	1
4	AES-D0008-8	FOAM BLOCK	1
3	AES-D0008-6	FOAM BLOCK	1
2	AES-D0008-4	FOAM BLOCK	1
1	AES-D0008-2	FOAM BLOCK	1
ITEM	PART NO.	DESCRIPTION	QTY

94	AES-D0008-188	FOAM BLOCK	1
93	AES-D0008-186	FOAM BLOCK	1
92	AES-D0008-184	FOAM BLOCK	1
91	AES-D0008-182	FOAM BLOCK	1
90	AES-D0008-180	FOAM BLOCK	1
89	AES-D0008-178	FOAM BLOCK	1
88	AES-D0008-176	FOAM BLOCK	1
87	AES-D0008-174	FOAM BLOCK	1
86	AES-D0008-172	FOAM BLOCK	1
85	AES-D0008-170	FOAM BLOCK	1
84	AES-D0008-168	FOAM BLOCK	1
83	AES-D0008-166	FOAM BLOCK	1
82	AES-D0008-164	FOAM BLOCK	1
81	AES-D0008-162	FOAM BLOCK	1
80	AES-D0008-160	FOAM BLOCK	1
79	AES-D0008-158	FOAM BLOCK	1
78	AES-D0008-156	FOAM BLOCK	1
77	AES-D0008-154	FOAM BLOCK	1
76	AES-D0008-152	FOAM BLOCK	1
75	AES-D0008-150	FOAM BLOCK	1
74	AES-D0008-148	FOAM BLOCK	1
73	AES-D0008-146	FOAM BLOCK	1
72	AES-D0008-144	FOAM BLOCK	1
71	AES-D0008-142	FOAM BLOCK	1
70	AES-D0008-140	FOAM BLOCK	1
69	AES-D0008-138	FOAM BLOCK	1
68	AES-D0008-136	FOAM BLOCK	1
67	AES-D0008-134	FOAM BLOCK	1
66	AES-D0008-132	FOAM BLOCK	1
65	AES-D0008-130	FOAM BLOCK	1
64	AES-D0008-128	FOAM BLOCK	1
63	AES-D0008-126	FOAM BLOCK	1
62	AES-D0008-124	FOAM BLOCK	1
61	AES-D0008-122	FOAM BLOCK	1
60	AES-D0008-120	FOAM BLOCK	1
59	AES-D0008-118	FOAM BLOCK	1
58	AES-D0008-116	FOAM BLOCK	1
57	AES-D0008-114	FOAM BLOCK	1
56	AES-D0008-112	FOAM BLOCK	1
55	AES-D0008-110	FOAM BLOCK	1
54	AES-D0008-108	FOAM BLOCK	1
53	AES-D0008-106	FOAM BLOCK	1
52	AES-D0008-104	FOAM BLOCK	1
51	AES-D0008-102	FOAM BLOCK	1
50	AES-D0008-100	FOAM BLOCK	1
49	AES-D0008-98	FOAM BLOCK	1
48	AES-D0008-96	FOAM BLOCK	1
ITEM	PART NO.	DESCRIPTION	QTY

141	AES-D0008-282	FOAM BLOCK	1
140	AES-D0008-280	FOAM BLOCK	1
139	AES-D0008-278	FOAM BLOCK	1
138	AES-D0008-276	FOAM BLOCK	1
137	AES-D0008-274	FOAM BLOCK	1
136	AES-D0008-272	FOAM BLOCK	1
135	AES-D0008-270	FOAM BLOCK	1
134	AES-D0008-268	FOAM BLOCK	1
133	AES-D0008-266	FOAM BLOCK	1
132	AES-D0008-264	FOAM BLOCK	1
131	AES-D0008-262	FOAM BLOCK	1
130	AES-D0008-260	FOAM BLOCK	1
129	AES-D0008-258	FOAM BLOCK	1
128	AES-D0008-256	FOAM BLOCK	1
127	AES-D0008-254	FOAM BLOCK	1
126	AES-D0008-252	FOAM BLOCK	1
125	AES-D0008-250	FOAM BLOCK	1
124	AES-D0008-248	FOAM BLOCK	1
123	AES-D0008-246	FOAM BLOCK	1
122	AES-D0008-244	FOAM BLOCK	1
121	AES-D0008-242	FOAM BLOCK	1
120	AES-D0008-240	FOAM BLOCK	1
119	AES-D0008-238	FOAM BLOCK	1
118	AES-D0008-236	FOAM BLOCK	1
117	AES-D0008-234	FOAM BLOCK	1
116	AES-D0008-232	FOAM BLOCK	1
115	AES-D0008-230	FOAM BLOCK	1
114	AES-D0008-228	FOAM BLOCK	1
113	AES-D0008-226	FOAM BLOCK	1
112	AES-D0008-224	FOAM BLOCK	1
111	AES-D0008-222	FOAM BLOCK	1
110	AES-D0008-220	FOAM BLOCK	1
109	AES-D0008-218	FOAM BLOCK	1
108	AES-D0008-216	FOAM BLOCK	1
107	AES-D0008-214	FOAM BLOCK	1
106	AES-D0008-212	FOAM BLOCK	1
105	AES-D0008-210	FOAM BLOCK	1
104	AES-D0008-208	FOAM BLOCK	1
103	AES-D0008-206	FOAM BLOCK	1
102	AES-D0008-204	FOAM BLOCK	1
101	AES-D0008-202	FOAM BLOCK	1
100	AES-D0008-200	FOAM BLOCK	1
99	AES-D0008-198	FOAM BLOCK	1
98	AES-D0008-196	FOAM BLOCK	1
97	AES-D0008-194	FOAM BLOCK	1
96	AES-D0008-192	FOAM BLOCK	1
95	AES-D0008-190	FOAM BLOCK	1
ITEM	PART NO.	DESCRIPTION	QTY

188	AES-D0008-376	FOAM BLOCK	1
187	AES-D0008-374	FOAM BLOCK	1
186	AES-D0008-372	FOAM BLOCK	1
185	AES-D0008-370	FOAM BLOCK	1
184	AES-D0008-368	FOAM BLOCK	1
183	AES-D0008-366	FOAM BLOCK	1
182	AES-D0008-364	FOAM BLOCK	1
181	AES-D0008-362	FOAM BLOCK	1
180	AES-D0008-360	FOAM BLOCK	1
179	AES-D0008-358	FOAM BLOCK	1
178	AES-D0008-356	FOAM BLOCK	1
177	AES-D0008-354	FOAM BLOCK	1
176	AES-D0008-352	FOAM BLOCK	1
175	AES-D0008-350	FOAM BLOCK	1
174	AES-D0008-348	FOAM BLOCK	1
173	AES-D0008-346	FOAM BLOCK	1
172	AES-D0008-344	FOAM BLOCK	1
171	AES-D0008-342	FOAM BLOCK	1
170	AES-D0008-340	FOAM BLOCK	1
169	AES-D0008-338	FOAM BLOCK	1
168	AES-D0008-336	FOAM BLOCK	1
167	AES-D0008-334	FOAM BLOCK	1
166	AES-D0008-332	FOAM BLOCK	1
165	AES-D0008-330	FOAM BLOCK	1
164	AES-D0008-328	FOAM BLOCK	1
163	AES-D0008-326	FOAM BLOCK	1
162	AES-D0008-324	FOAM BLOCK	1
161	AES-D0008-322	FOAM BLOCK	1
160	AES-D0008-320	FOAM BLOCK	1
159	AES-D0008-318	FOAM BLOCK	1
158	AES-D0008-316	FOAM BLOCK	1
157	AES-D0008-314	FOAM BLOCK	1
156	AES-D0008-312	FOAM BLOCK	1
155	AES-D0008-310	FOAM BLOCK	1
154	AES-D0008-308	FOAM BLOCK	1
153	AES-D0008-306	FOAM BLOCK	1
152	AES-D0008-304	FOAM BLOCK	1
151	AES-D0008-302	FOAM BLOCK	1
150	AES-D0008-300	FOAM BLOCK	1
149	AES-D0008-298	FOAM BLOCK	1
148	AES-D0008-296	FOAM BLOCK	1
147	AES-D0008-294	FOAM BLOCK	1
146	AES-D0008-292	FOAM BLOCK	1
145	AES-D0008-290	FOAM BLOCK	1
144	AES-D0008-288	FOAM BLOCK	1
143	AES-D0008-286	FOAM BLOCK	1
142	AES-D0008-284	FOAM BLOCK	1
ITEM	PART NO.	DESCRIPTION	QTY



DRAWING NUMBER				
AES-D0008				
SIZE	SCALE	SHEET	OF	REVISION
A3	NONE	1	190	B

GENERAL NOTES:

- GN1 FOAM TO BE IN ACCORDANCE WITH MIL SPEC MIL-PRF-87260B, CLASS 2 - GRADE 1 (COARSE PORE).
- GN2 IF BULK FOAM MATERIAL IS PROVIDED, THE FOAM SHOULD BE RECEIVED IN A MULTIPACKED CONFIGURATION FROM THE SUPPLIER TO ENSURE NO CONTAMINATION. MULTIPLE BUNS MAY BE CONTAINED IN A PACKAGE BUT EACH BUN MUST BE INDIVIDUALLY PACKED. UPON RECEIPT OF THE PACKAGES, CHECK THE PACKAGING FOR DAMAGE. IF DAMAGE IS PRESENT, CHECK THE FOAM FOR DAMAGE / CONTAMINATION. REFER TO SAE SPECIFICATION AIR4170 REV. B, PARAGRAPH 3.7.1 FOR INFORMATION ON PACKAGING DAMAGE.
- GN3 STORAGE OF THE FOAM MUST BE IN UNDAMAGED PACKAGING AWAY FROM ULTRAVIOLET LIGHT AND IN AN ENVIRONMENT WHERE CONTAMINATION IS AVOIDED. REFER TO SAE SPECIFICATION AIR4170 REV. B, PARAGRAPH 3.7.1 FOR INFORMATION ON PACKAGING DAMAGE.
- GN4 THE FABRICATOR'S MANUFACTURING AREA SHOULD MEET REQUIRED CLEANLINESS TO CONTROL CONTAMINANTS THAT WOULD ADVERSELY AFFECT THE MATERIAL OR ITS FUNCTIONALITY. IT IS EXTREMELY IMPORTANT TO CONTROL SUCH CONTAMINANTS AS FOREIGN PARTICLES, METAL PARTICLES, DUST, SUNLIGHT, WATER, WATER VAPOR STEAM, HARMFUL LIQUIDS, AND HARMFUL GASES. MANUFACTURING MANAGEMENT SHOULD ADDRESS THE REQUIREMENTS IDENTIFIED IN SAE SPECIFICATION AIR4170 REV. B, PARAGRAPH 3.7.3.
- GN5 CUTTING AND SHAPING OF INDIVIDUAL FOAM COMPONENTS CAN BE ACCOMPLISHED BY THE FOLLOWING METHODS:
 A. HOT WIRE CUTTING (SEE SAE SPECIFICATION AIR4170 REV. B, PARAGRAPH 3.7.3.1).
 B. MECHANICAL BLADE TYPE CUTTING (BAND SAW, ELECTRIC KNIFE) (SEE SAE SPECIFICATION AIR4170 REV. B, PARAGRAPH 3.7.3.2)
 C. SPECIALLY DESIGNED / MANUFACTURED SMOOTH BLADE TYPE CUTTING TOOLS.
- GN6 HANDLING OF RETICULATED POLYURETHANE FOAM SHOULD NOT RESULT IN THE TRANSFER OF FOREIGN MATERIALS ONTO, OR INTO THE FOAM STRUCTURE. THE CLOTHING WORN BY PERSONNEL FABRICATING THE COMPONENTS/KITS SHOULD NOT BE A SOURCE OF CONTAMINATION TO THE FUEL CELL BAFFLE MATERIAL. REFER TO SAE SPECIFICATION AIR4170 REV. B, PARAGRAPH 3.7.3.3 FOR FURTHER DETAILS.
- GN7 UPON COMPLETION OF FABRICATION AND BEFORE FINAL INSPECTION, COMPONENTS WILL REQUIRE A FINAL CLEANING TO REMOVE ANY FOAM DEBRIS OR CONTAMINANTS LEFT FROM THE FABRICATING PROCESS. ALL COMPONENTS MUST BE BOUNCED AND THOROUGHLY SCRUBBED ON A SCREEN OR HARDWARE CLOTH TO REMOVE LOOSE PARTICLES OF FOAM AND/OR BEADS OF MELTED FOAM AS A RESULT OF FABRICATION. REFER TO SAE SPECIFICATION AIR4170 REV. B, PARAGRAPH 3.7.3.4 FOR INFORMATION ON CLEANING.
- GN8 COMPONENT IDENTIFICATION NUMBERS/LETTERS MUST BE APPLIED TO EACH COMPONENT AFTER FABRICATION IN THE POSITION SHOWN ON THE DRAWINGS. REFER GN10 & GN11 FOR ADDITIONAL DETAILS. PART MARKING MUST ALSO INCLUDE DATE OF FABRICATION. INK TO BE IN ACCORDANCE WITH FEDERAL SPECIFICATION A-A-208() IN A CONTRASTING COLOUR.
- GN9 IMMEDIATELY UPON COMPLETING THE CLEANING AND IDENTIFICATION MARKING OF A COMPONENT IT SHALL BE PACKAGED TO PREVENT POSSIBLE CONTAMINATION. MINIMUM LEVEL OF PROTECTION WHEN PACKAGING SHOULD BE AS FOLLOWS:
 - EACH INDIVIDUAL COMPONENT SHALL BE WRAPPED IN A 4-MIL, BLACK POLYETHYLENE FILM, TAPED OR SEALED CLOSED, AND PROPERLY IDENTIFIED
 - INDIVIDUALLY WRAPPED COMPONENTS SHALL THEN BE MULTIPACKED INTO COMMERCIAL GRADE CORRUGATED CARTONS, AND SEALED CLOSED WITH TAPE. MARKINGS ON THE EXTERIOR CARTON SHALL IDENTIFY THE CONTENTS. THE PACKAGED COMPONENTS/KITS SHALL BE STORED IN AN AREA TO PROTECT THEM FROM THE OUTDOOR ENVIRONMENT.
 REFER TO SAE SPECIFICATION AIR4170 REV. B, PARAGRAPH 3.7.6 FOR INFORMATION ON PACKAGING AND STORAGE
- GN10 MARKINGS ON THE FOAM REPRESENT THE FOLLOWING:
 'F' - FACE OF FOAM FACING FORWARD OF THE AIRCRAFT
 'A' - FACE OF FOAM FACING AFT OF THE AIRCRAFT
 - 'THIS END UP' ARROW
- GN11 PART NUMBER AND ALL MARKINGS PER GN10 TO BE MARKED IN POSITION SHOWN ON DRAWING. THE TEXT HEIGHT FOR FACE OF FOAM ('F' OR 'A') AND ARROW IS 3 INCHES. THE TEXT HEIGHT FOR PART NUMBER IS 1.5 INCHES. HOWEVER, IF CONSTRAINED FOR SPACE PART NUMBER CAN BE MARKED ON ADJACENT FACES. ARROWS NEED TO BE CONSPICUOUS.
- GN12 PAGE 0 CONTAINS REV BLOCK, DOC NAME/REV/DATE/NUMBER, TOLERANCES, SIGNATURES AND INDEX.

FLAG NOTES:

-  ARROW INDICATES DIRECTION OF AIRCRAFT RELATIVE TO THE FOAM SECTION VIEW. THIS IS TO ASSIST MARKINGS ON THE FOAM BLOCK.

	DRAWING NUMBER				AES-D0008	
	SIZE	SCALE	SHEET	OF	REVISION	
A3	NONE	2	190		B	

1 2 3 4 5 6 7 8

A B C D E F

1
2

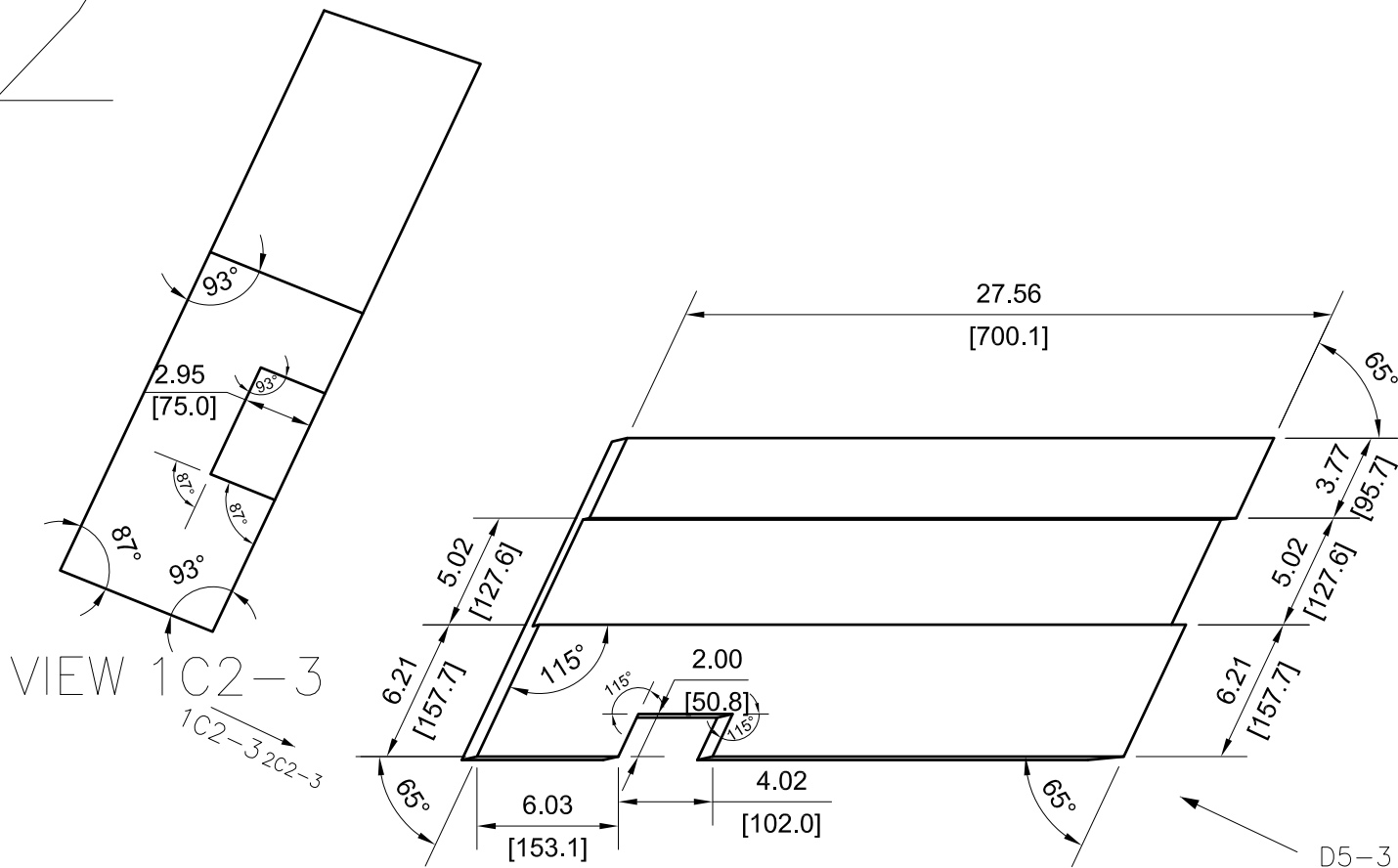

VIEW 1C2-3
1C2-3 2C2-3

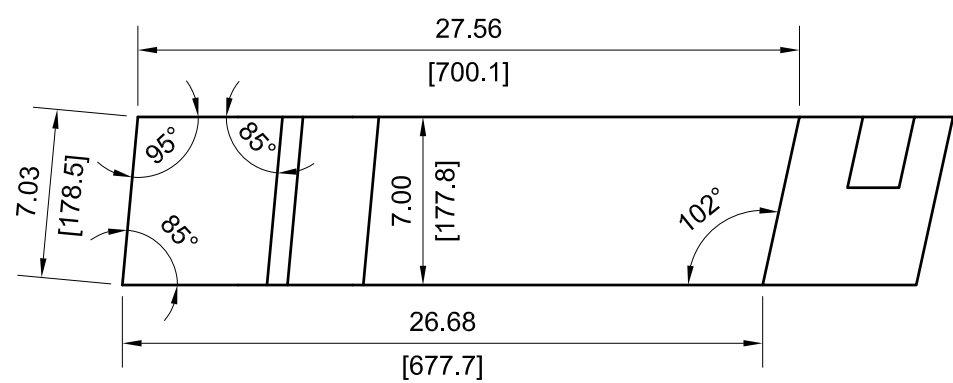
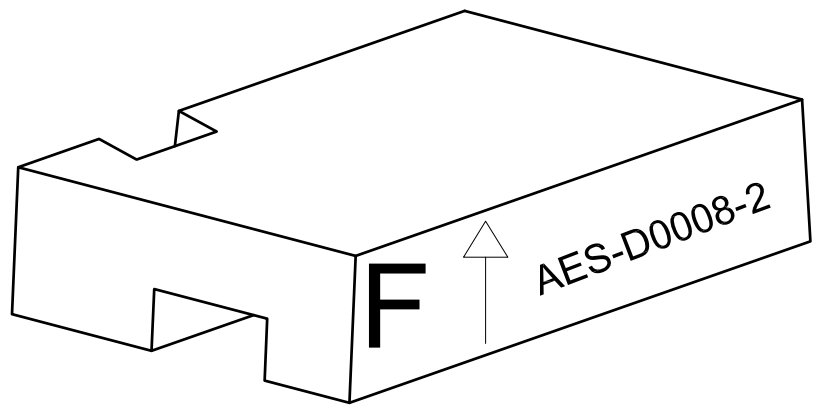

D5-3 E6-3

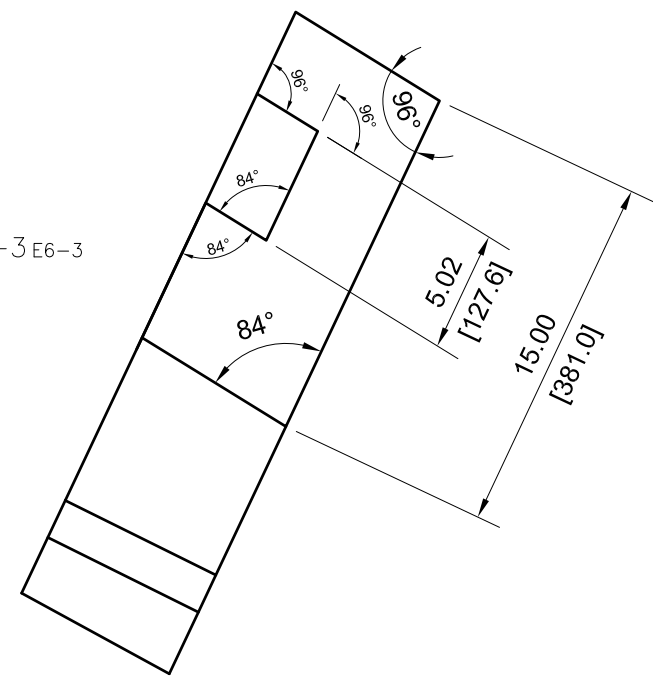

VIEW D5-3

1 2 3 4 5 6 7 8

	DRAWING NUMBER				
	AES-D0008				
SIZE	SCALE	SHEET	OF	REVISION	
A3	NONE	3	190	B	

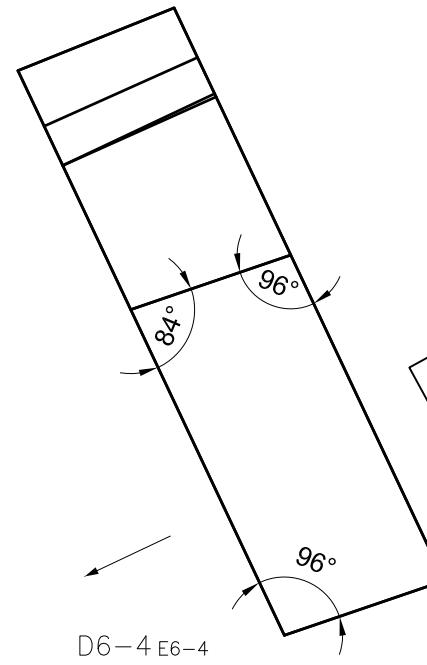
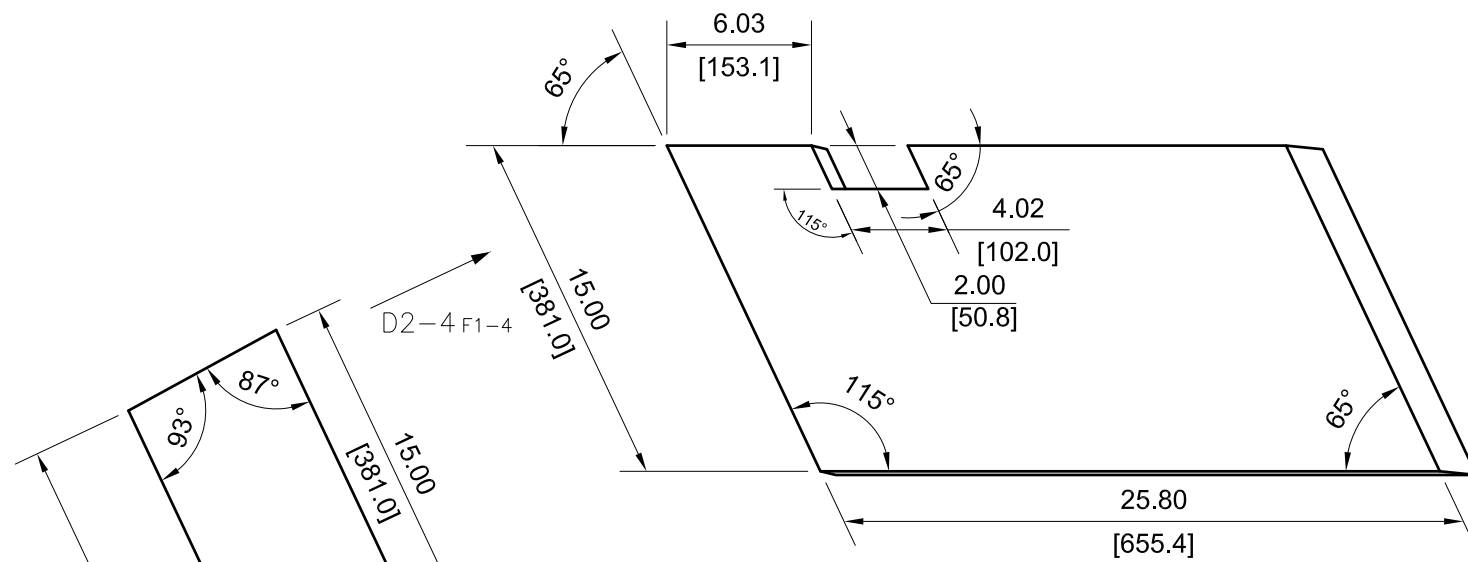
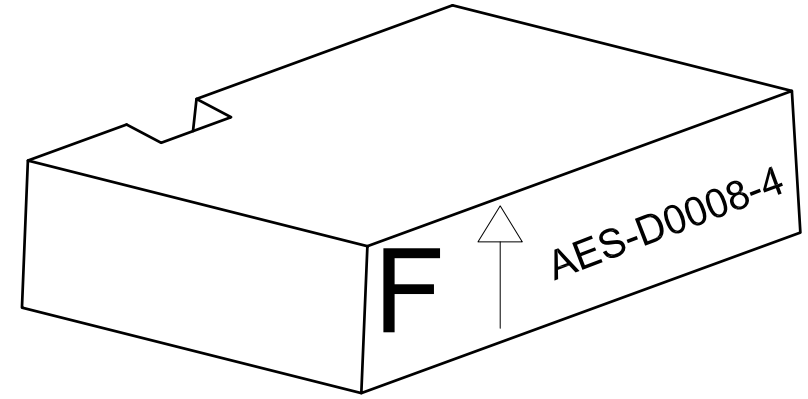
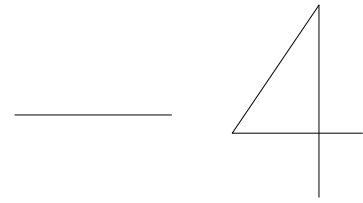

END

VIEW D6-4

VIEW D2-4

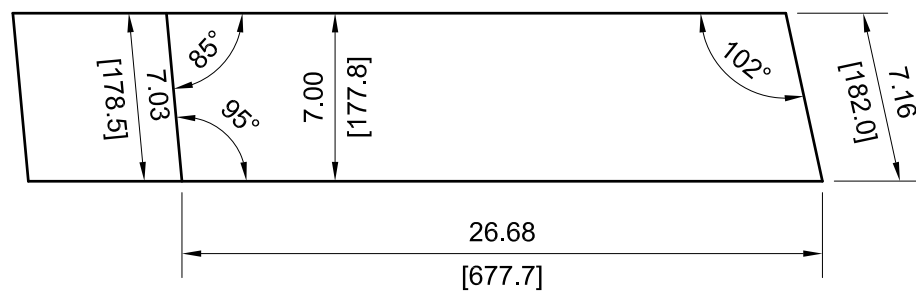

UP



DRAWING NUMBER					AES-D0008	
SIZE	SCALE	SHEET	OF	REVISION		
A3	NONE	4	190	B		

1 2 3 4 5 6 7 8

A B C D E F

6

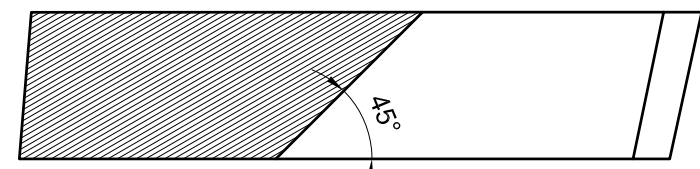
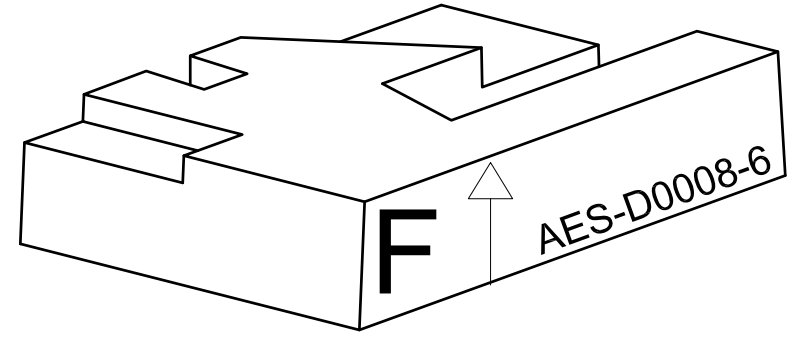

SECTION VIEW E2-5

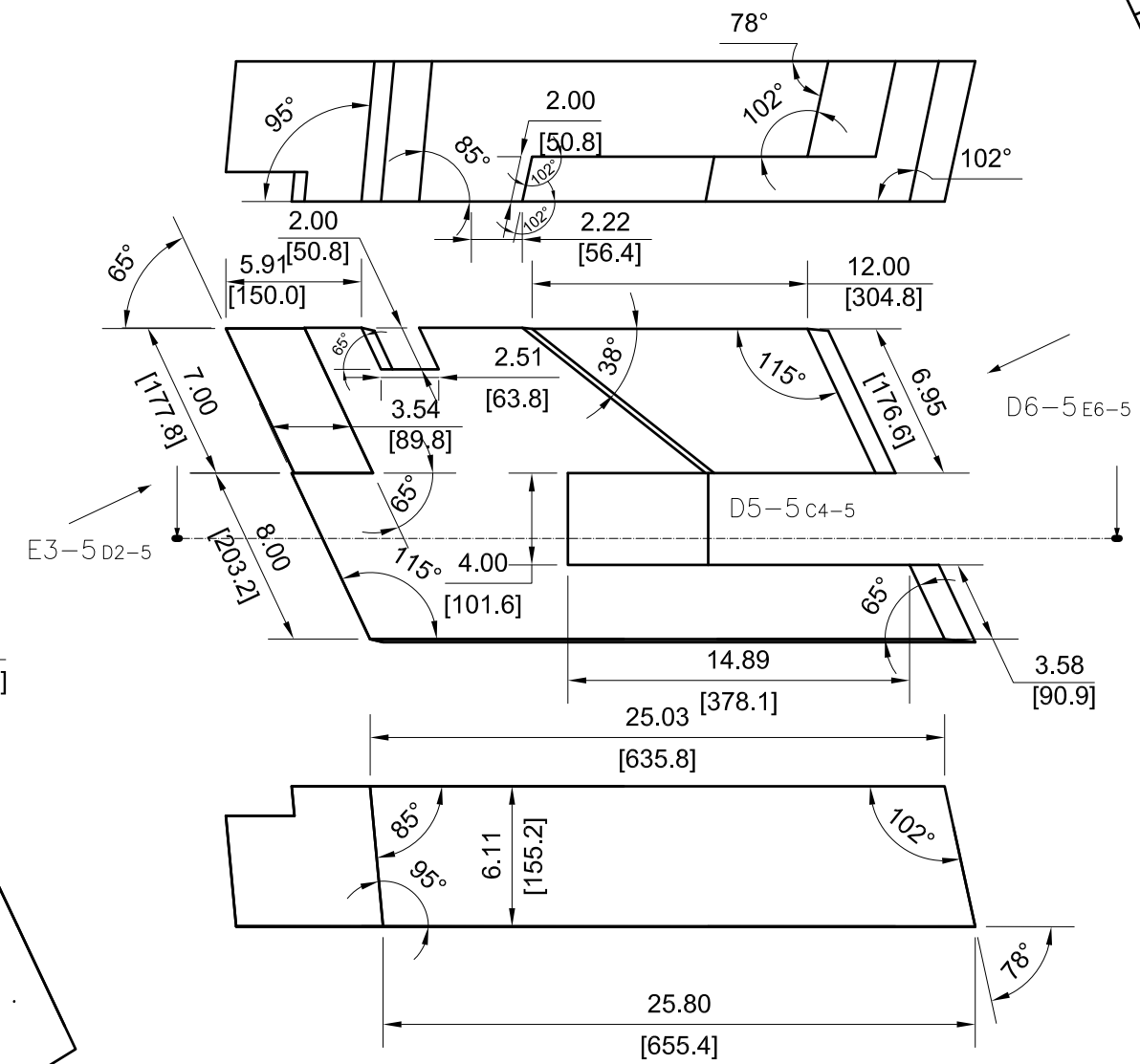

VIEW E3-5

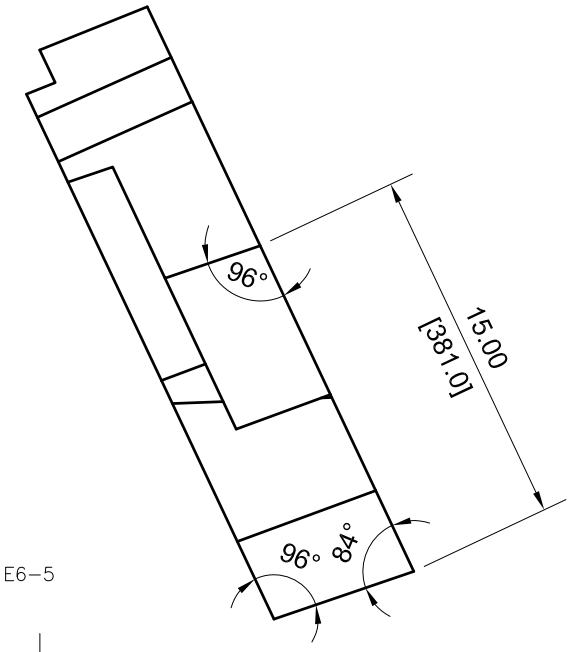
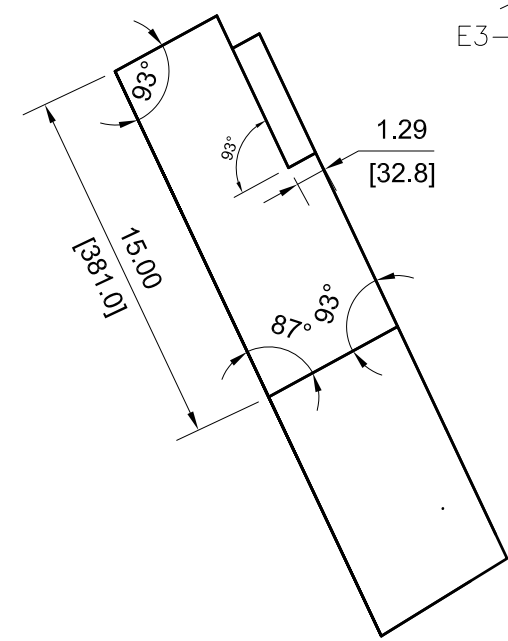

VIEW D6-5



DRAWING NUMBER					AES-D0008	
SIZE	SCALE	SHEET	OF	REVISION		
A3	NONE	5	190	B		

1 2 3 4 5 6 7 8

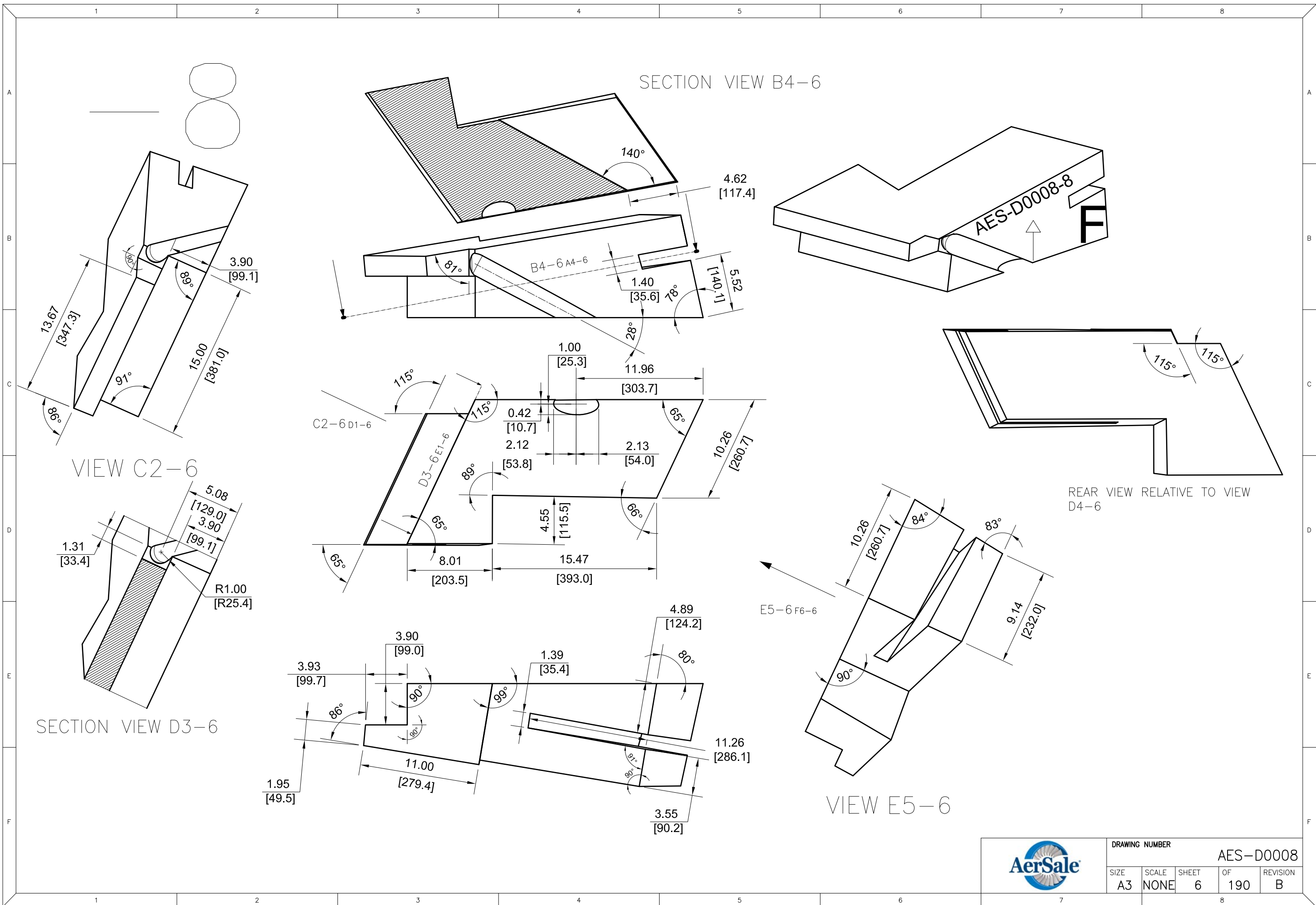

DRAWING NUMBER					AES-D0008				
SIZE	SCALE	SHEET	OF	REVISION					
A3	NONE	6	190	B					

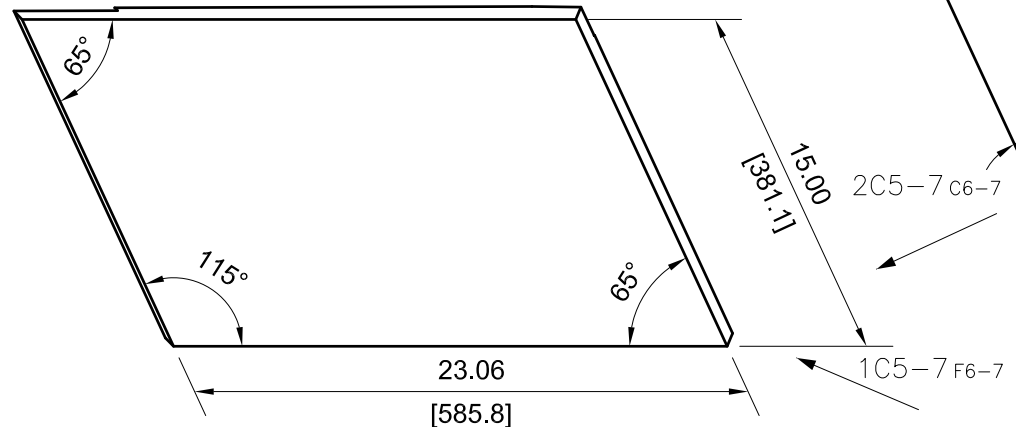
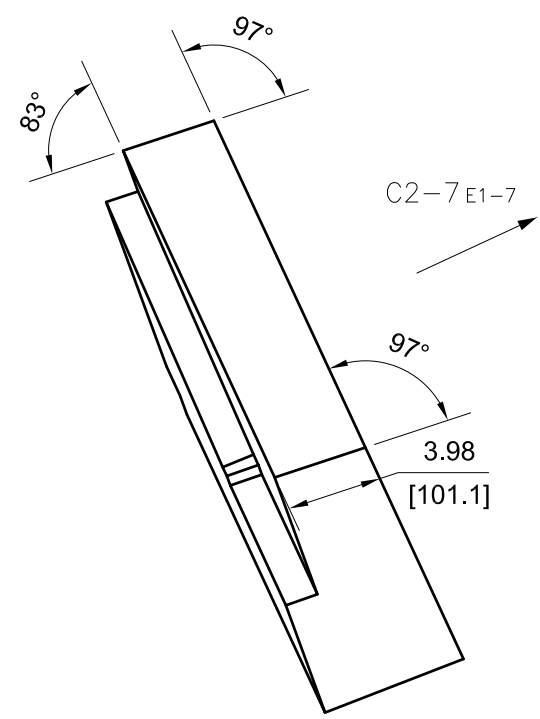
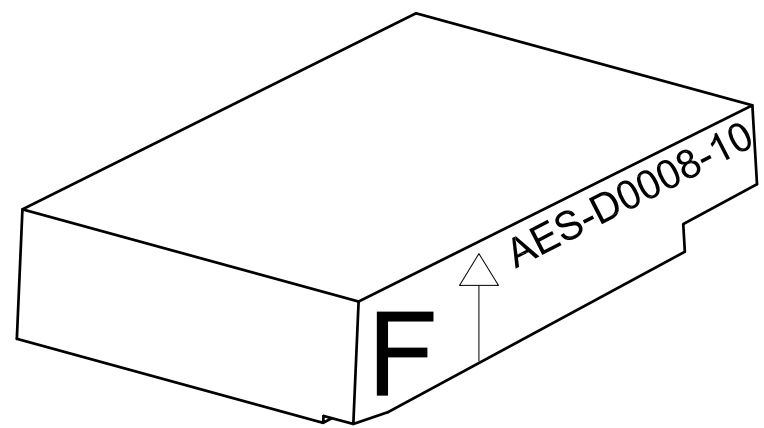
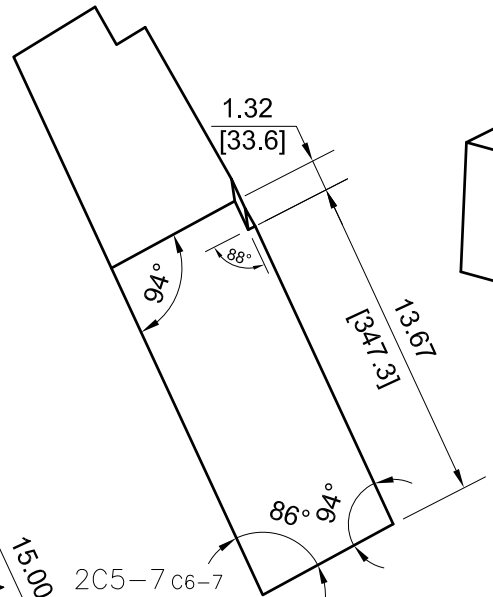
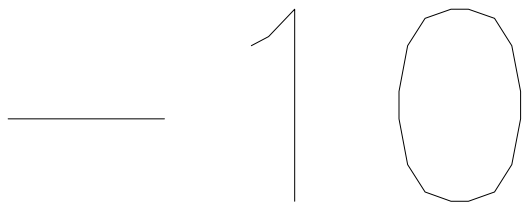

VIEW 2C5-7

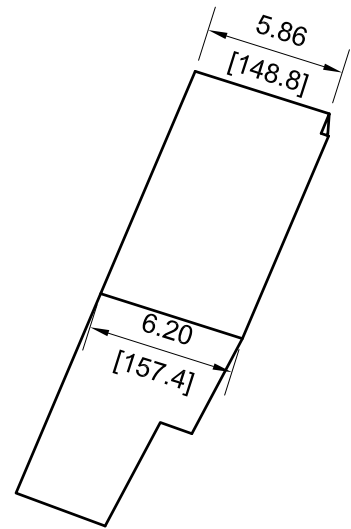
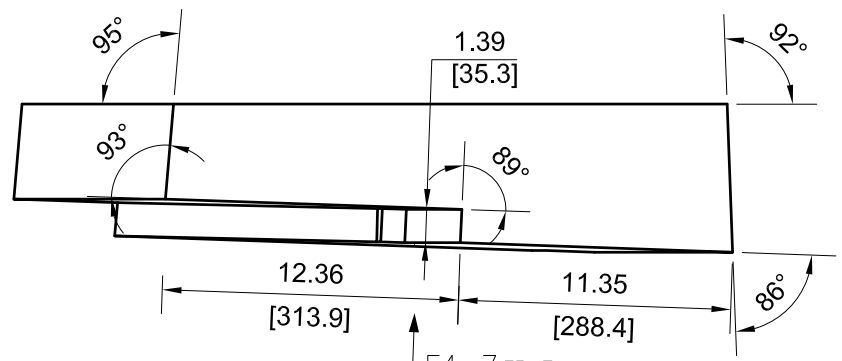

VIEW 1C5-7

VIEW C2-7

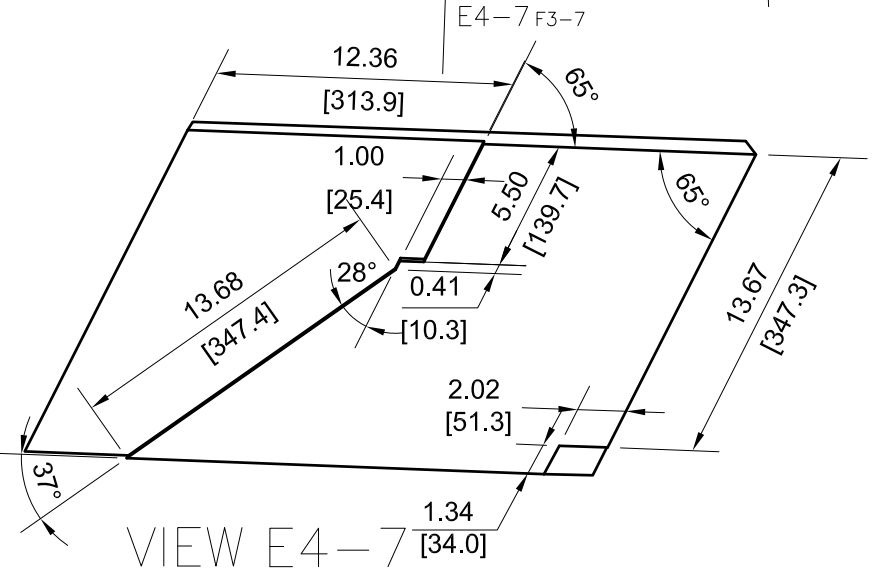

VIEW E4-7

		DRAWING NUMBER			
		AES-D0008			
SIZE	SCALE	SHEET	OF	REVISION	
A3	NONE	7	190	B	

12

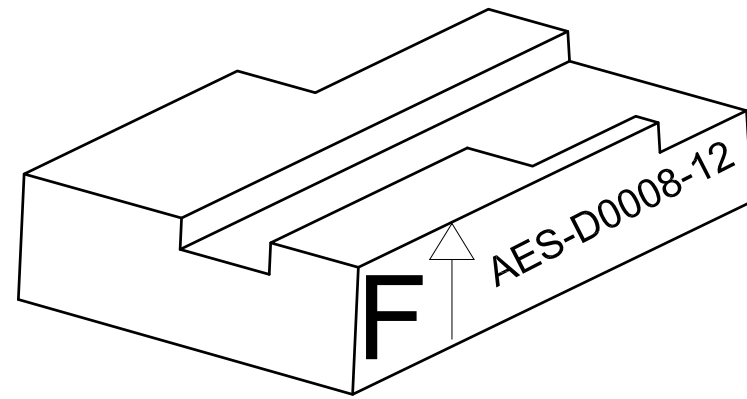

VIEW D3-8

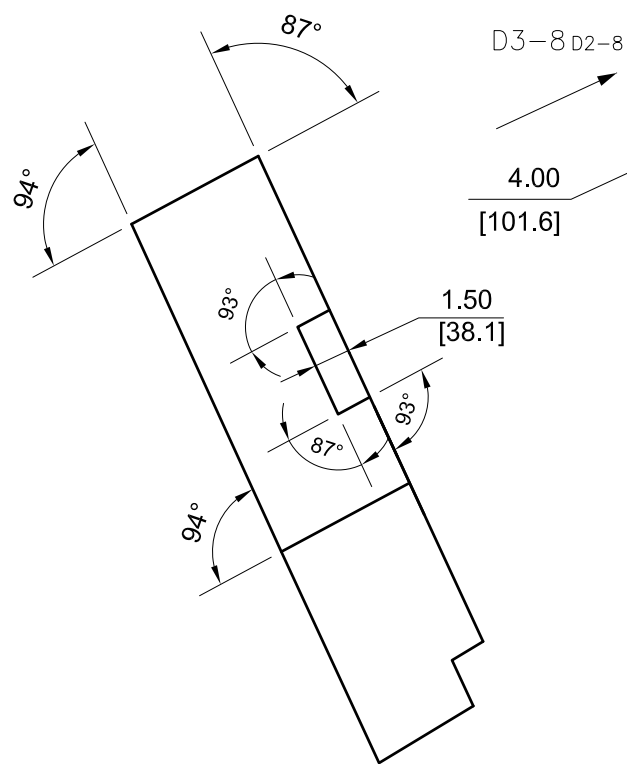

VIEW D6-8

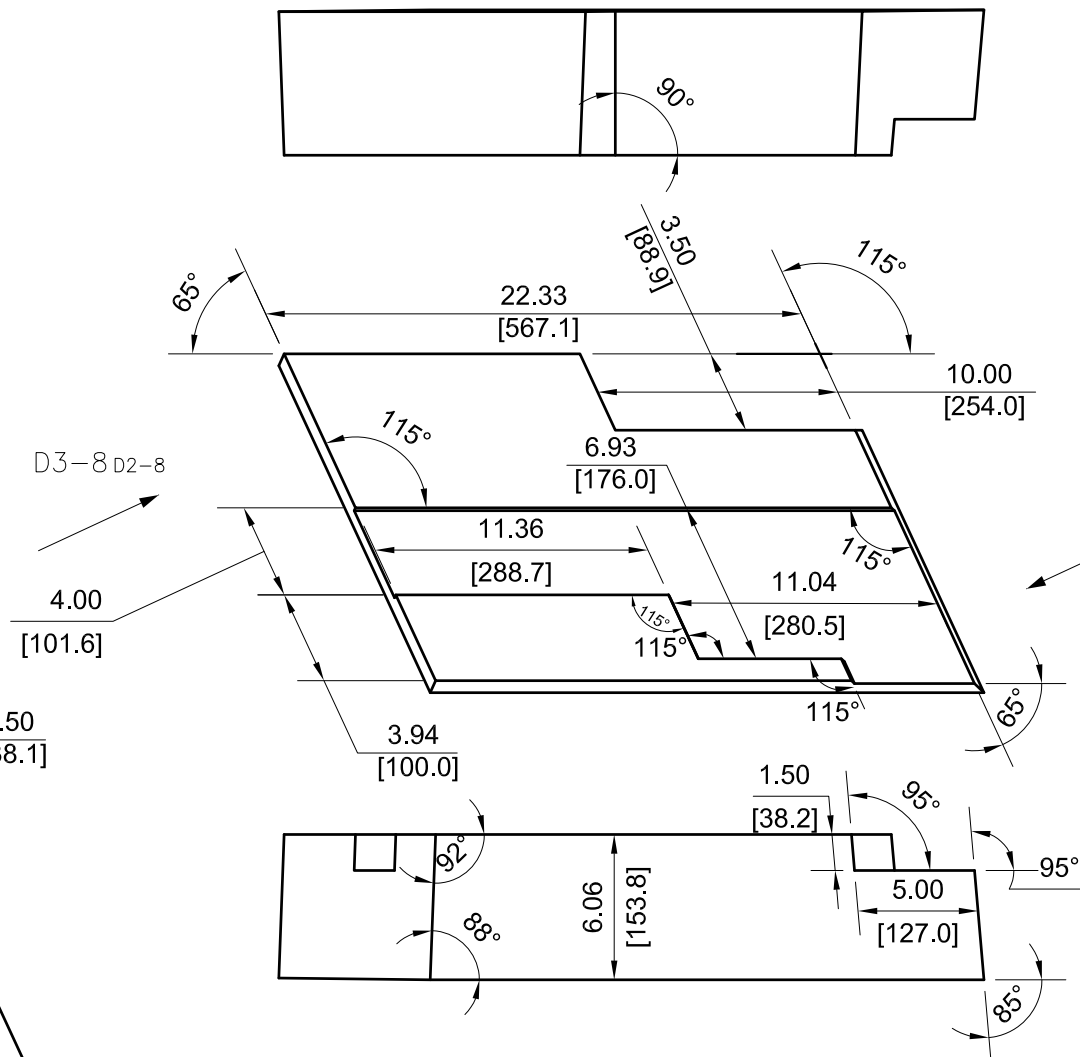
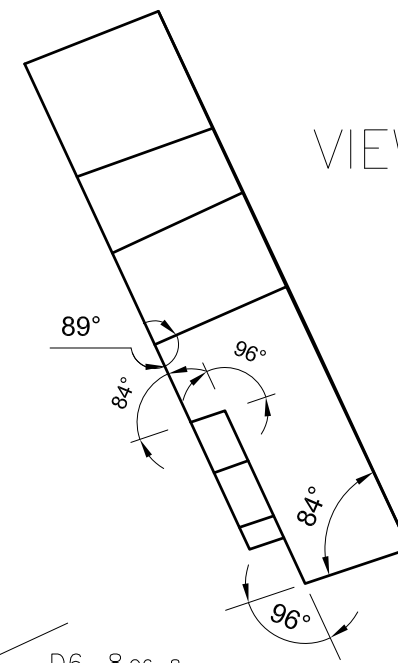

DRAWING NUMBER				
AES-D0008				
SIZE	SCALE	SHEET	OF	REVISION
A3	NONE	8	190	B

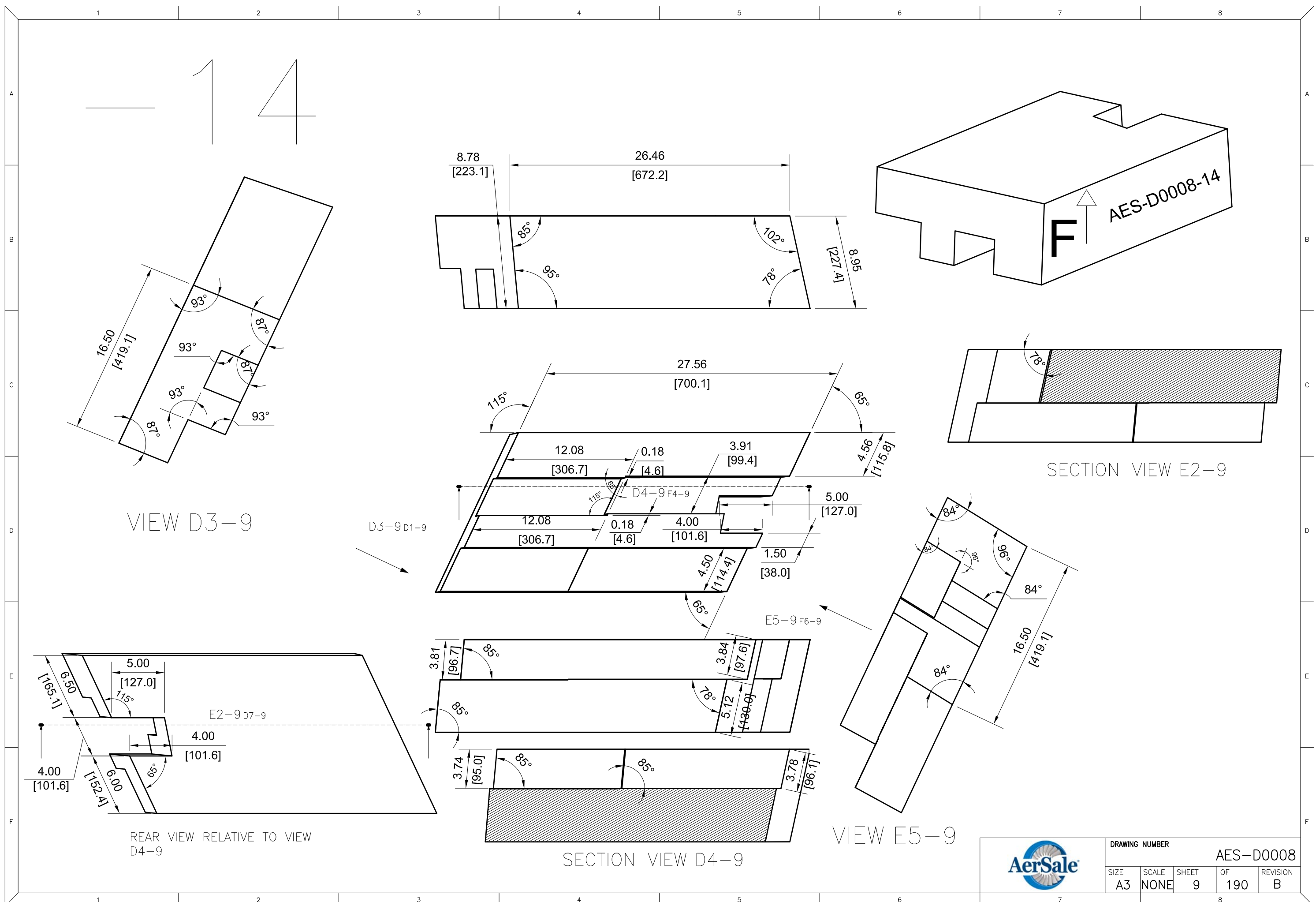

		DRAWING NUMBER			
		AES-D0008			
SIZE	SCALE	SHEET	OF	REVISION	
A3	NONE	9	190	B	

16

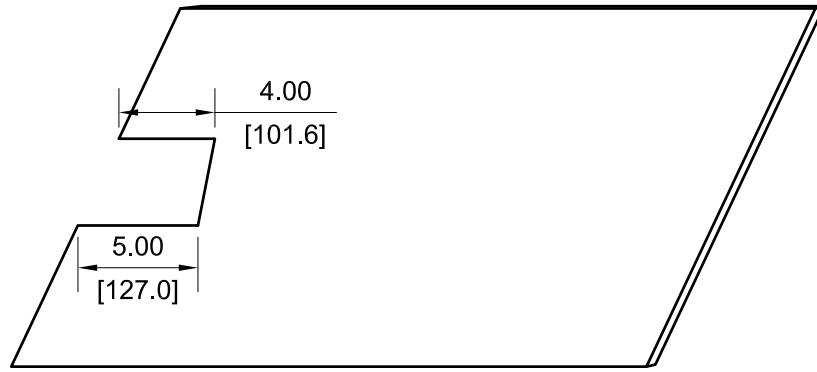

REAR VIEW RELATIVE TO VIEW D4-10

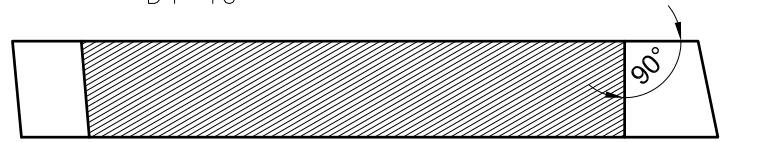

SECTION VIEW D4-10

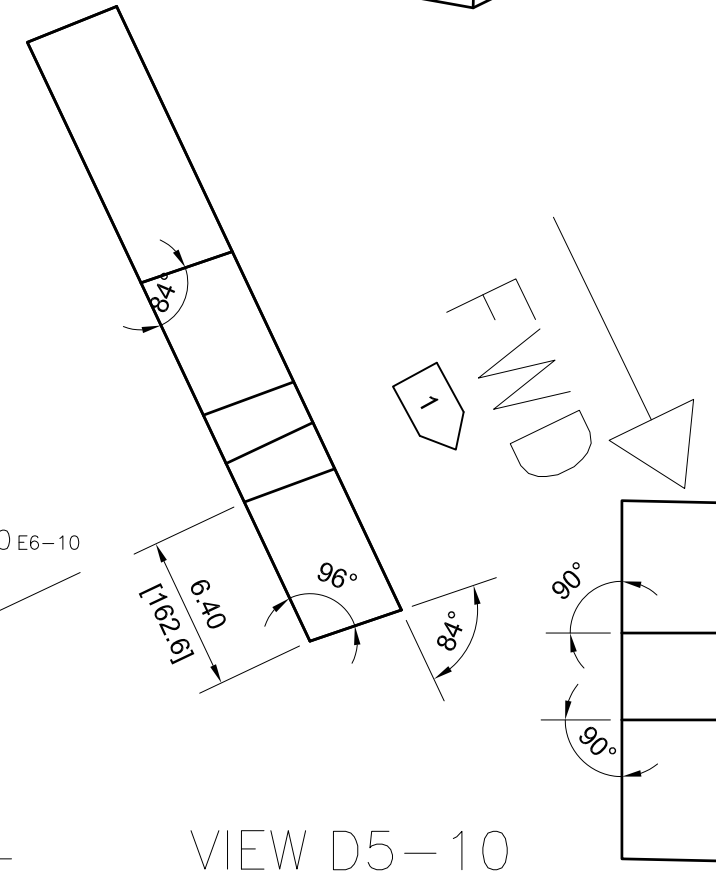
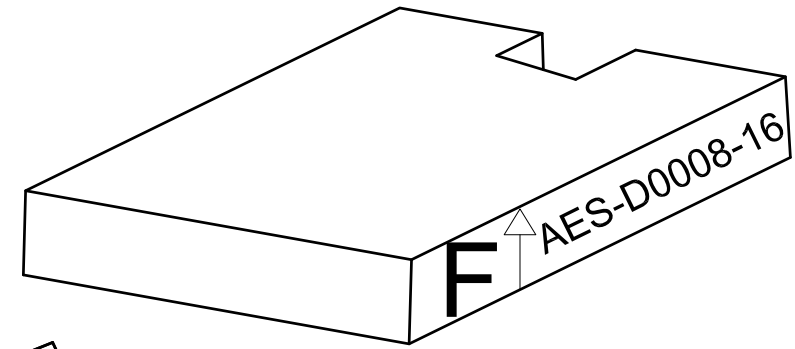
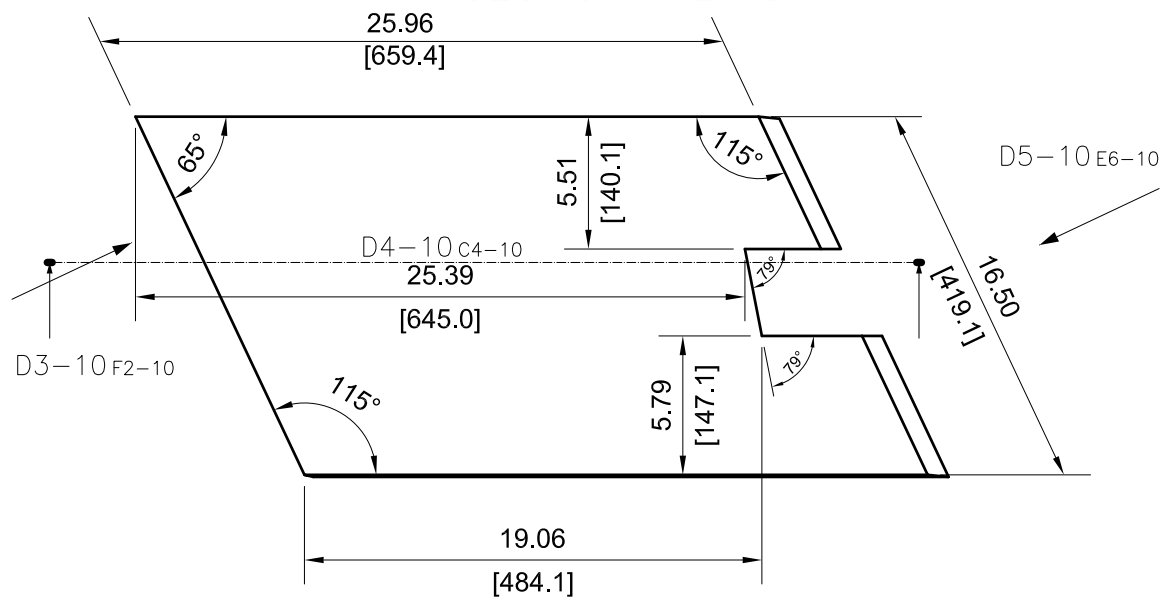

VIEW D5-10

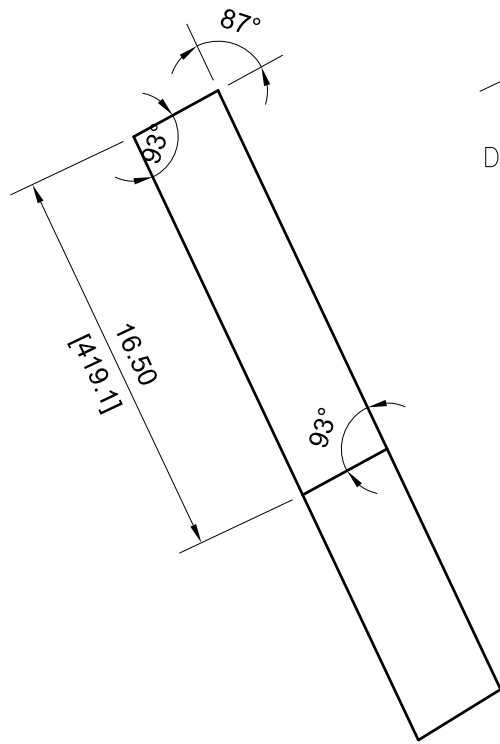

VIEW D3-10

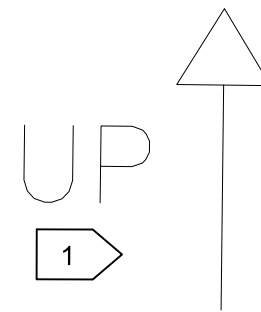
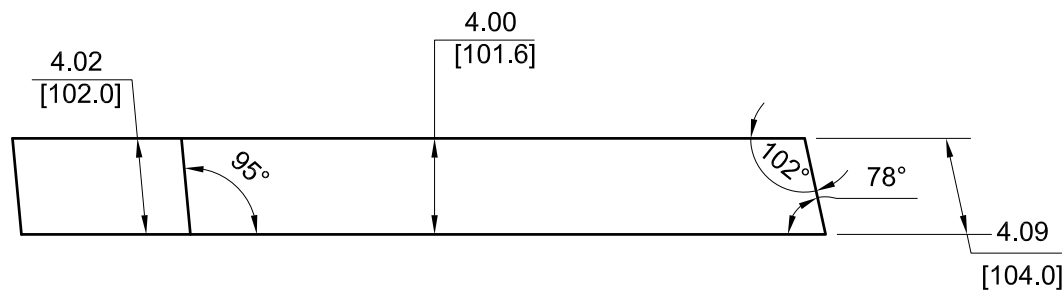

DRAWING NUMBER					AES-D0008	
SIZE	SCALE	SHEET	OF	REVISION		
A3	NONE	10	190	B		

18

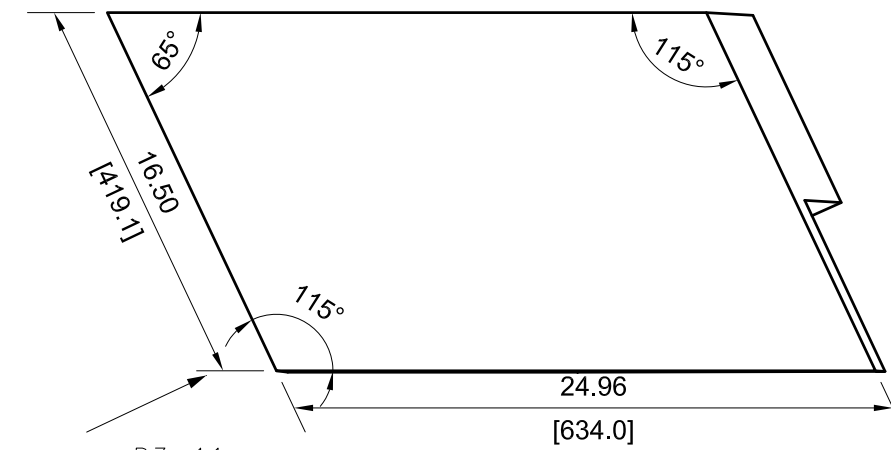
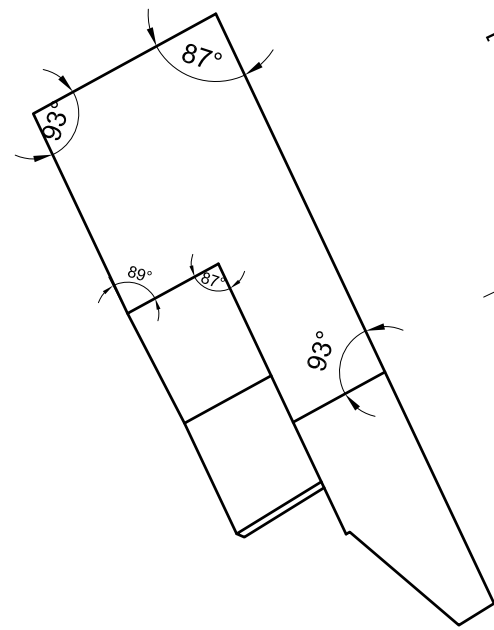
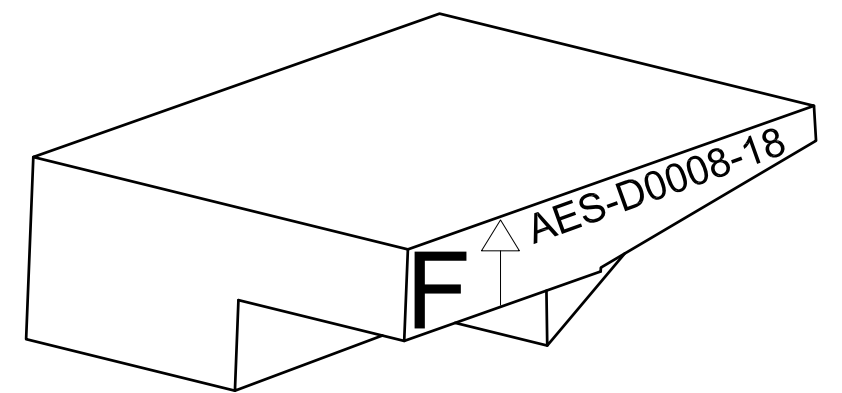
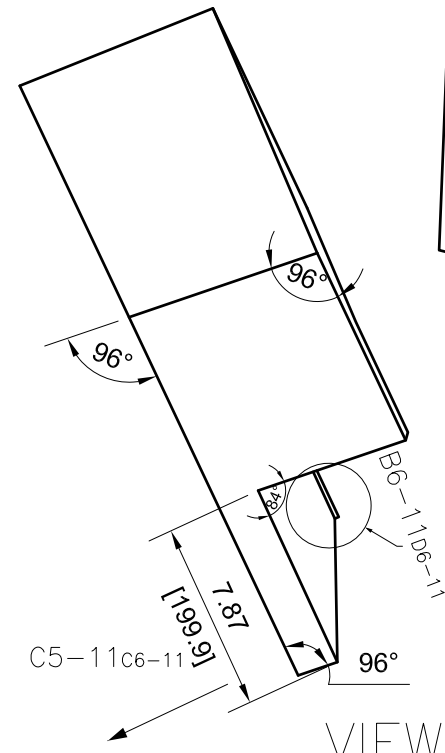
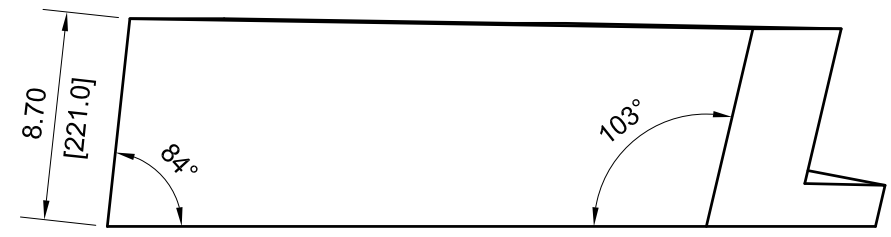

VIEW C5-11

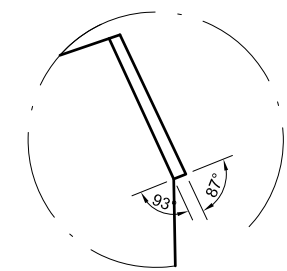

DETAIL B6-11

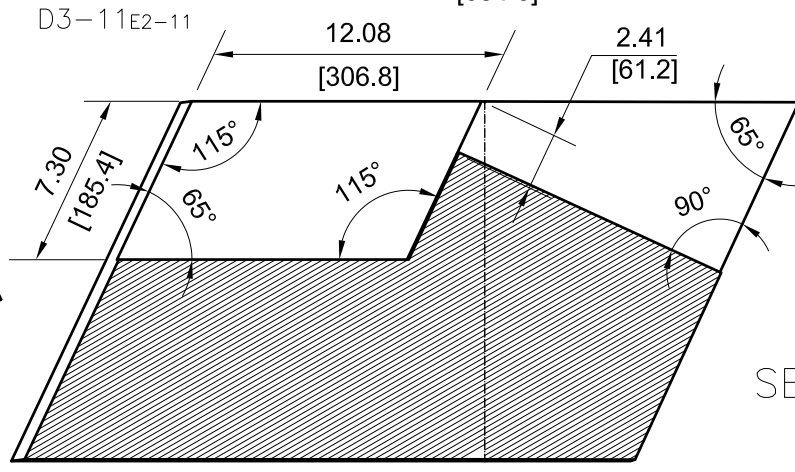

SECTION VIEW 1F4-11

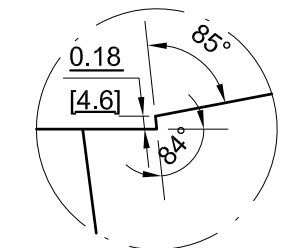

DETAIL 2F4-11

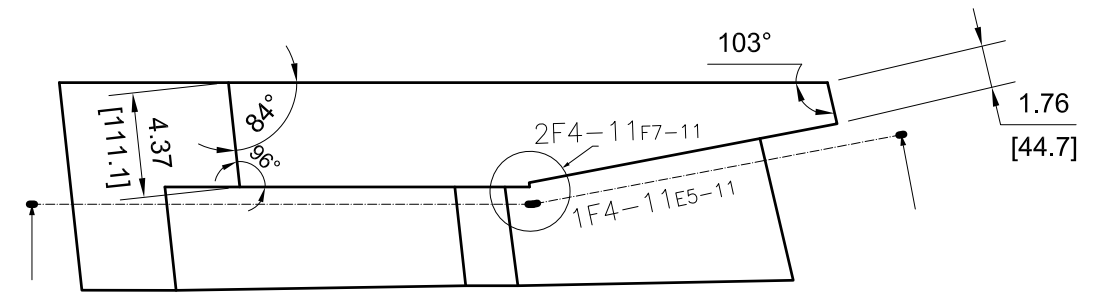

VIEW D3-11



DRAWING NUMBER					AES-D0008	
SIZE	SCALE	SHEET	OF	REVISION		
A3	NONE	11	190	B		

20

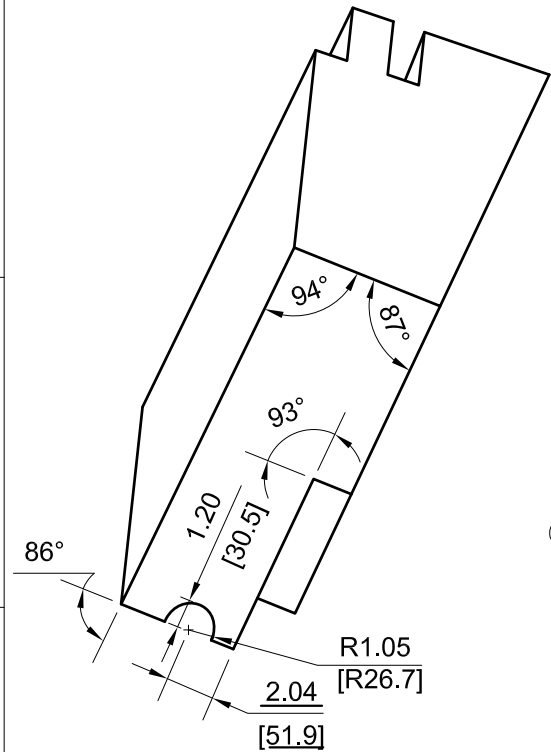

VIEW C2-12

C2-12 D1-12

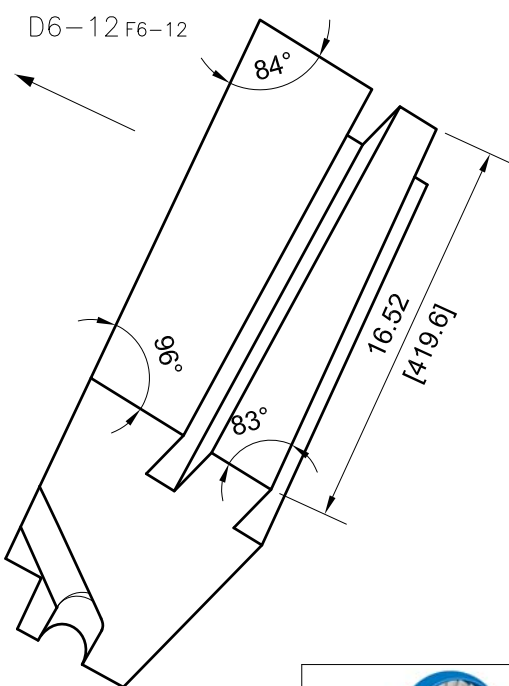
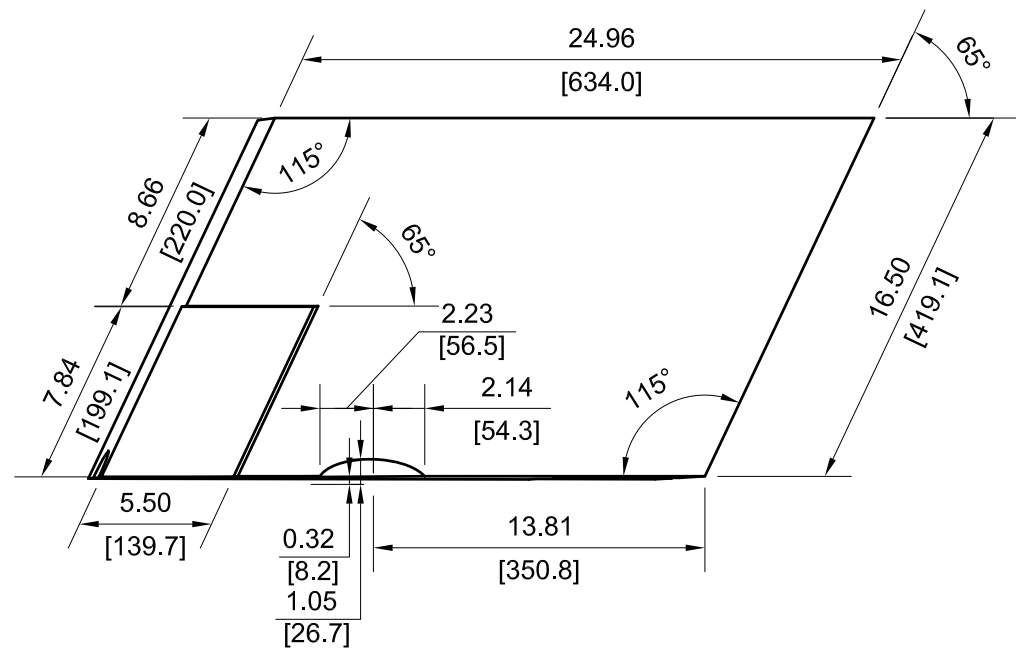
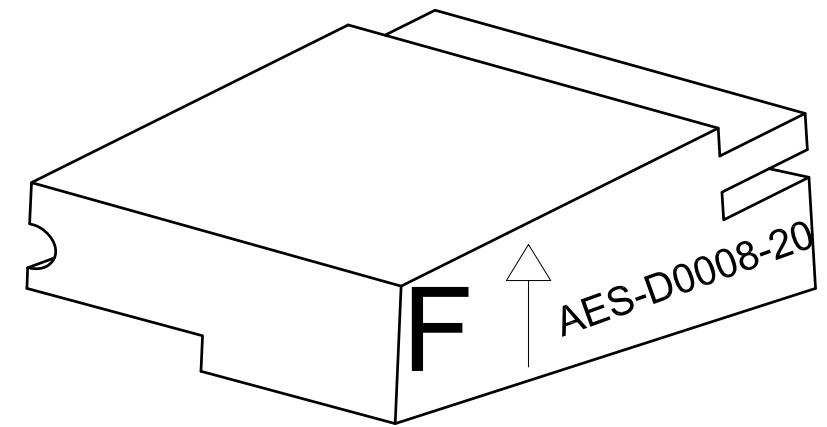
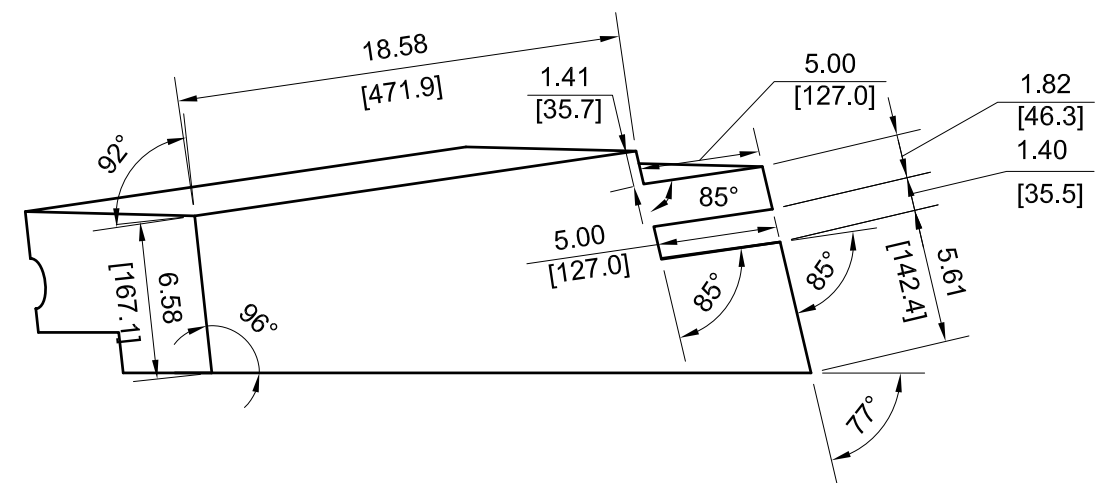

VIEW D6-12

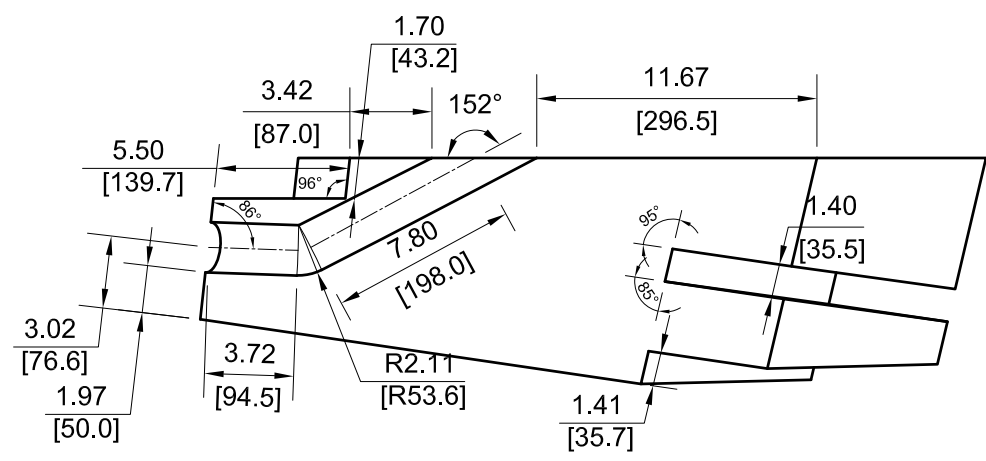

DRAWING NUMBER				
AES-D0008				
SIZE	SCALE	SHEET	OF	REVISION
A3	NONE	12	190	B

22

VIEW C3-13

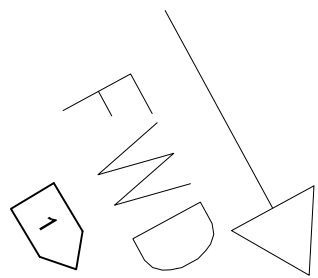
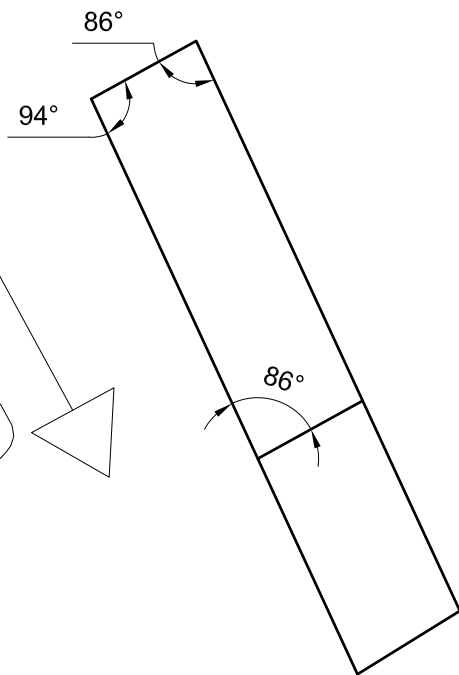
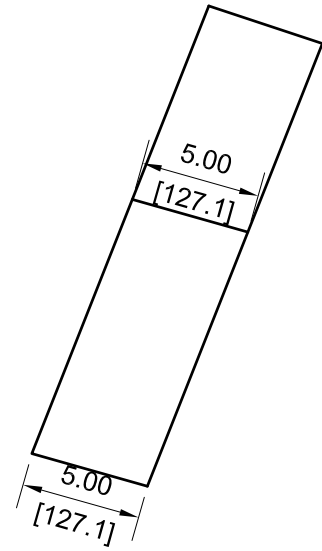

VIEW D3-13

C3-13 B2-13

D3-13 F2-13

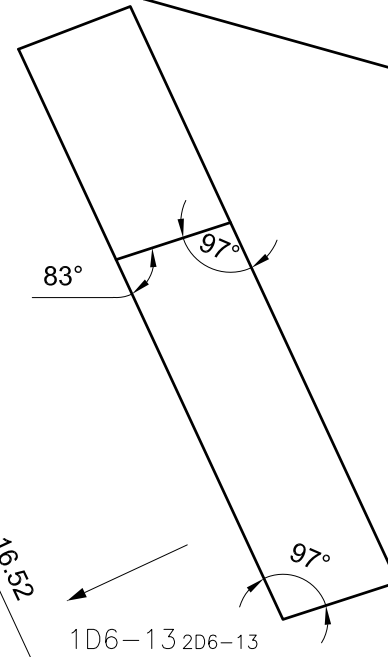
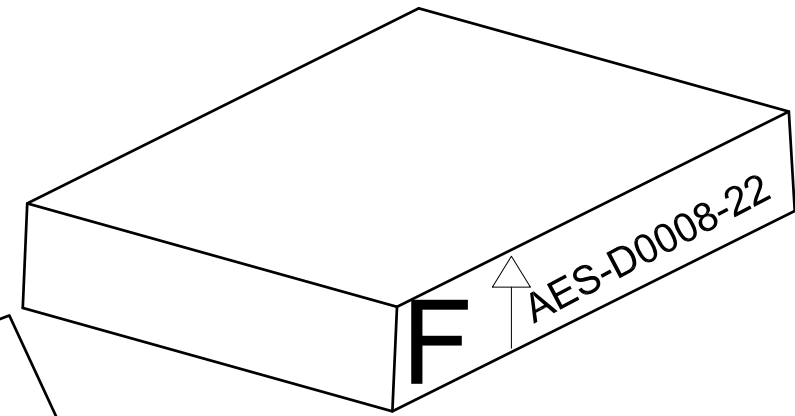
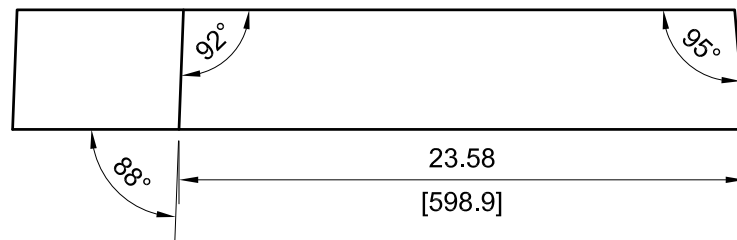
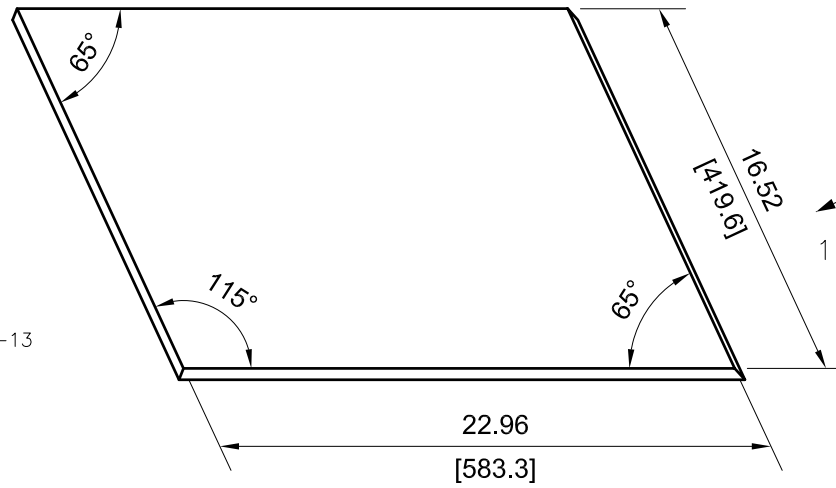

1D6-13 2D6-13

VIEW 1D6-13

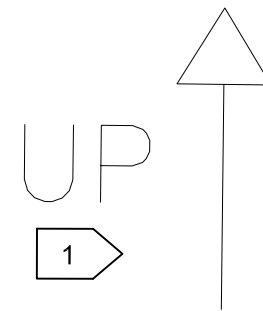

DRAWING NUMBER					AES-D0008	
SIZE	SCALE	SHEET	OF	REVISION		
A3	NONE	13	190	B		

24

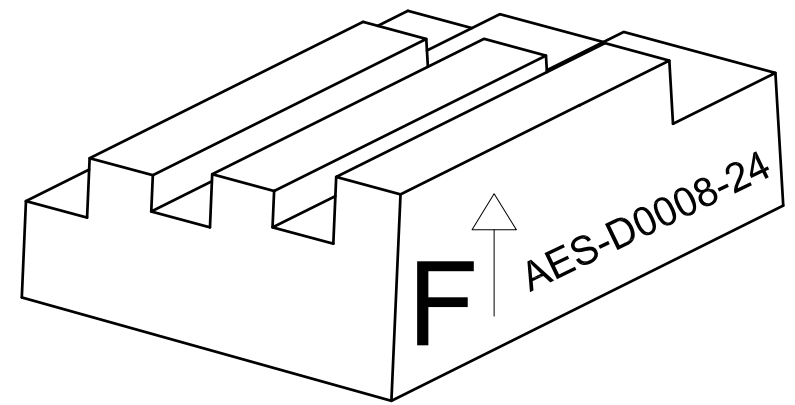
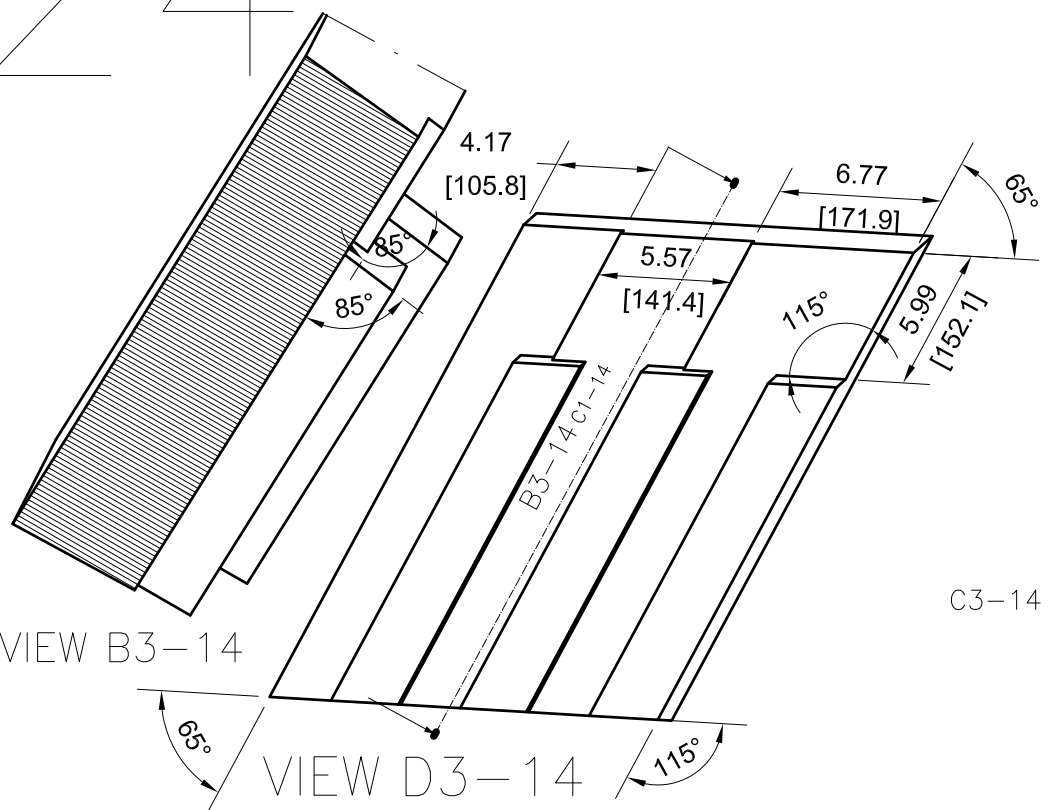

VIEW C3-14

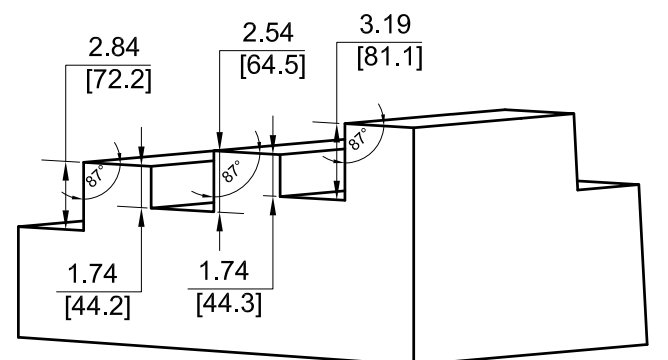
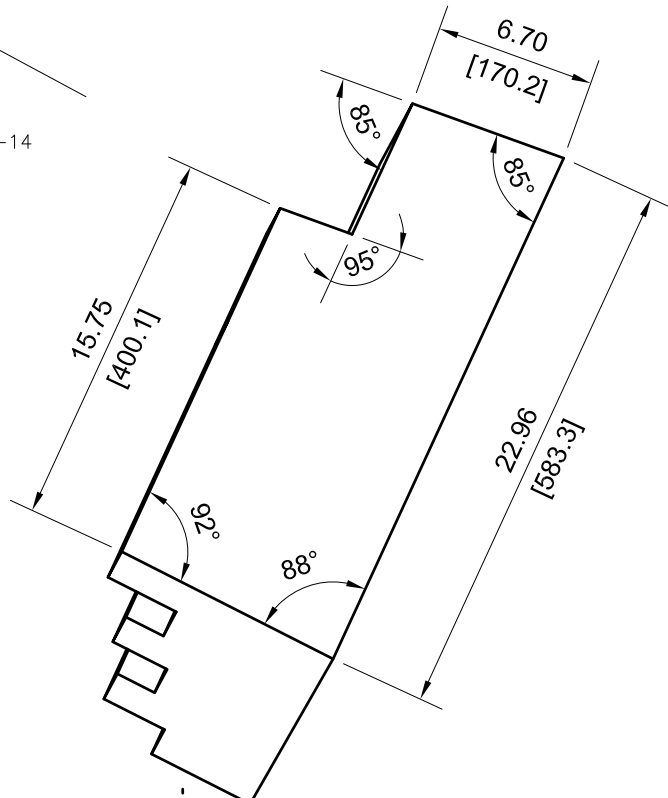

D3-14 c2-14

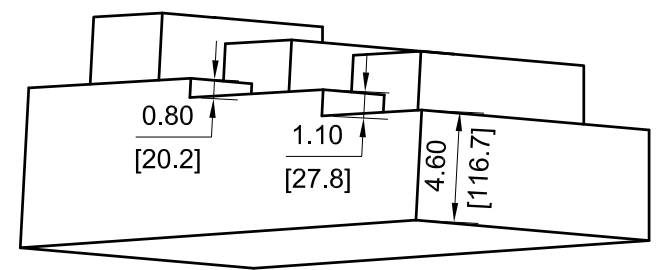
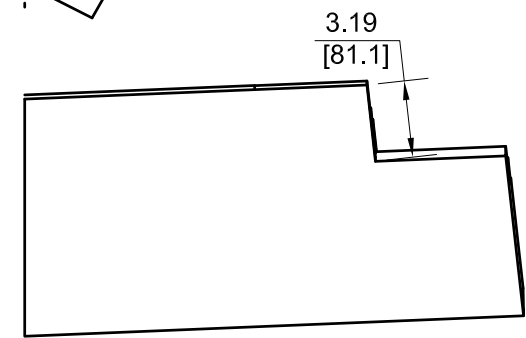
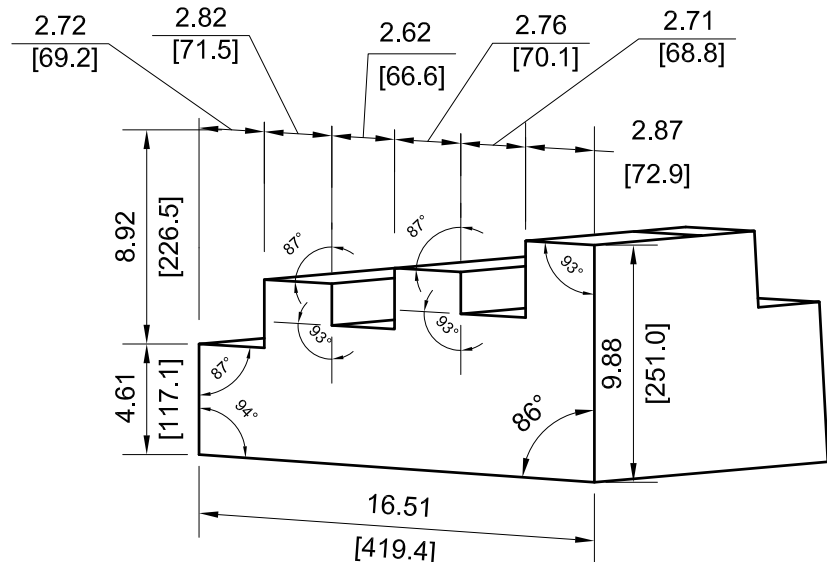

	DRAWING NUMBER				
	AES-D0008				
SIZE	SCALE	SHEET	OF	REVISION	
A3	NONE	14	190	B	

26

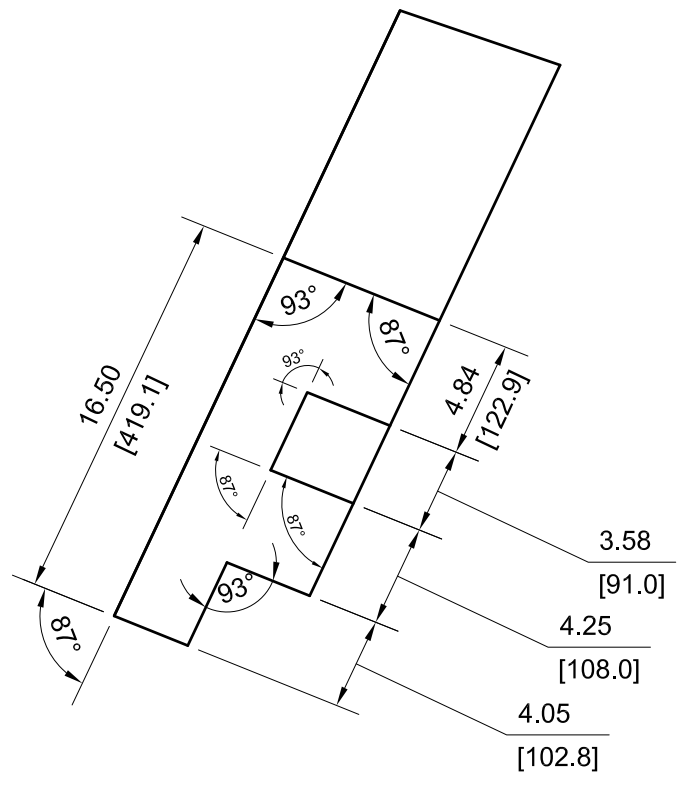

VIEW D3-15

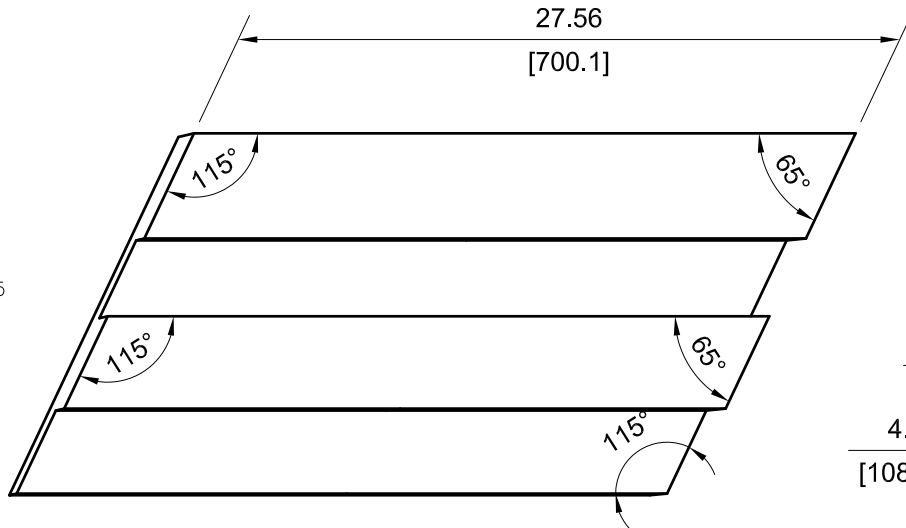
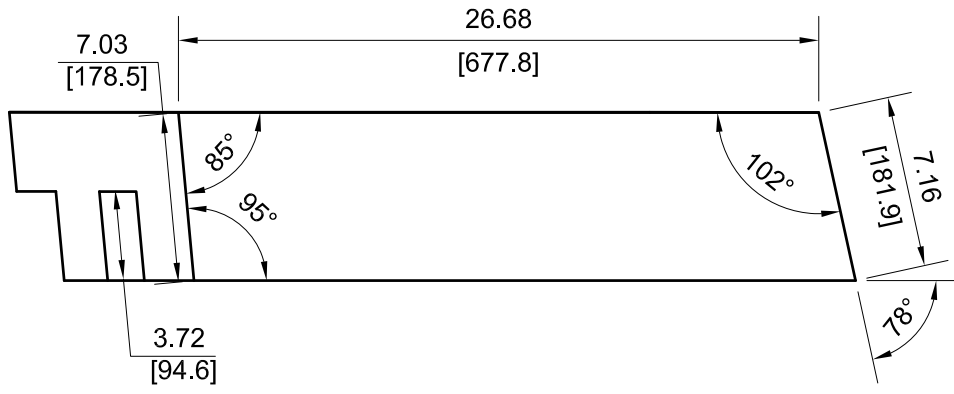

D3-15 D1-15

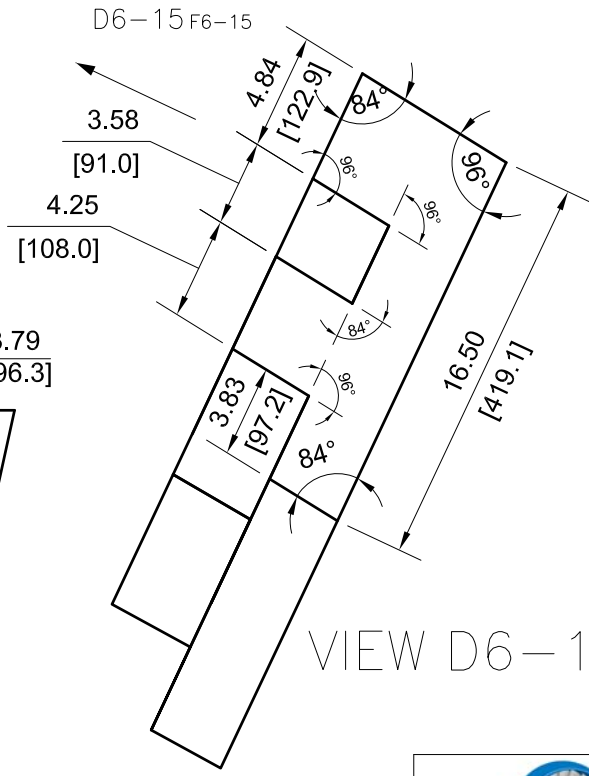
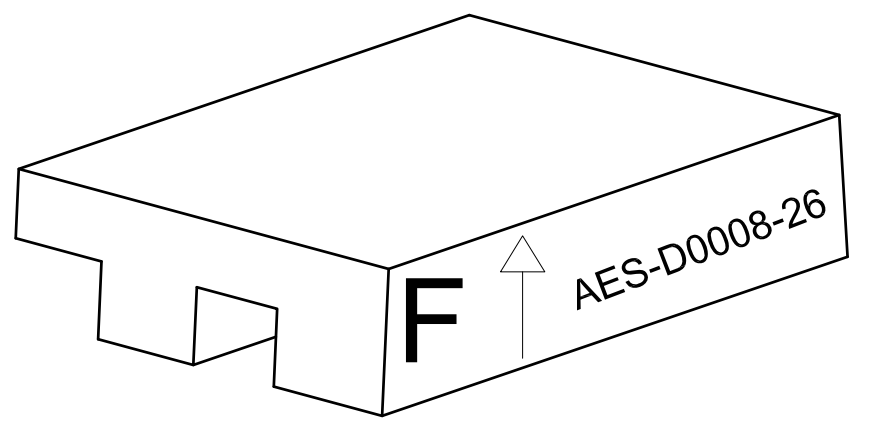
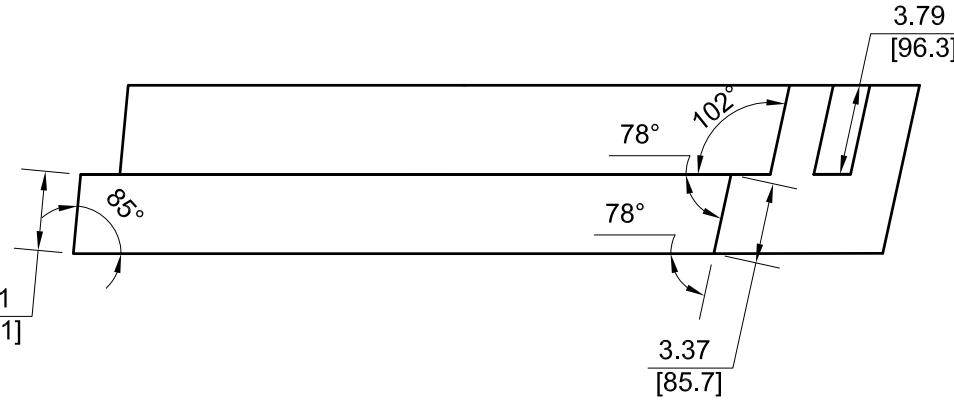

VIEW D6-15



DRAWING NUMBER				
AES-D0008				
SIZE	SCALE	SHEET	OF	REVISION
A3	NONE	15	190	B

— 28

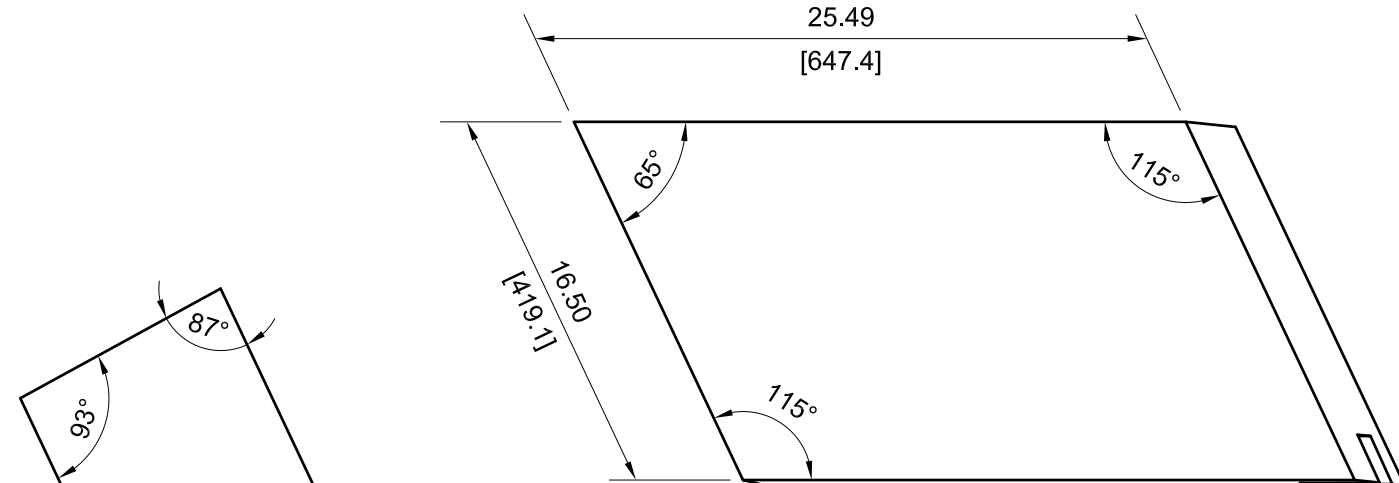
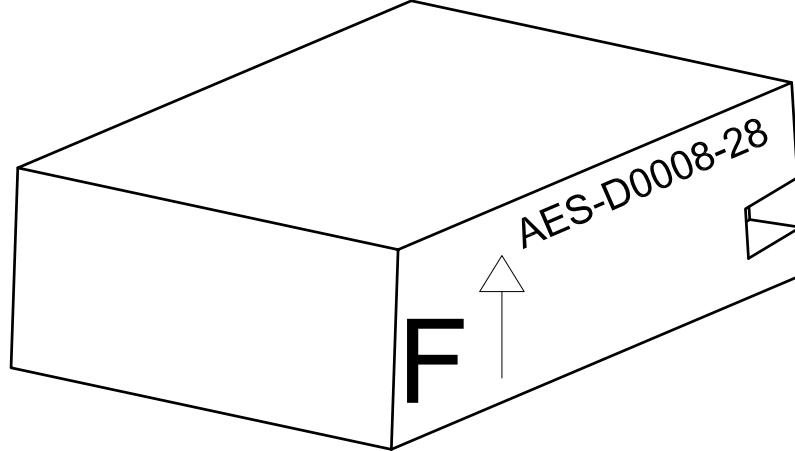

E2-16 F2-16

VIEW E2-16

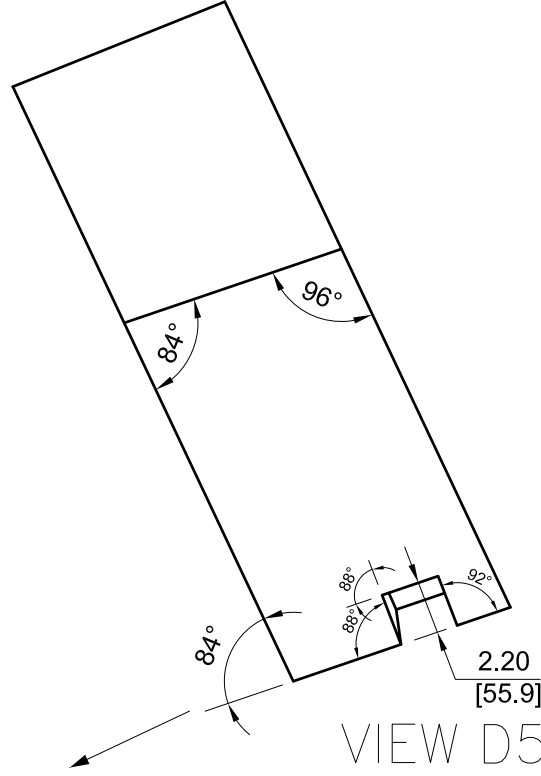

D5-16 D6-16

VIEW D5-16

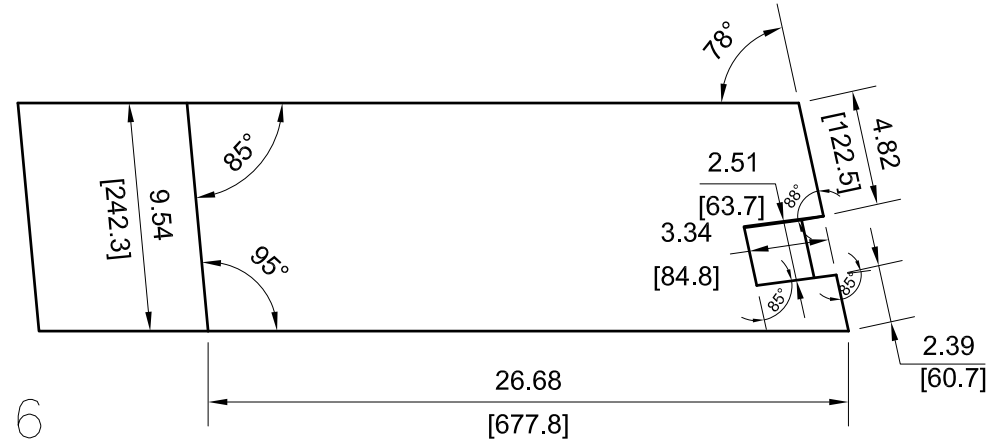

DRAWING NUMBER					AES-D0008	
SIZE	SCALE	SHEET	OF	REVISION		
A3	NONE	16	190	B		

— 30

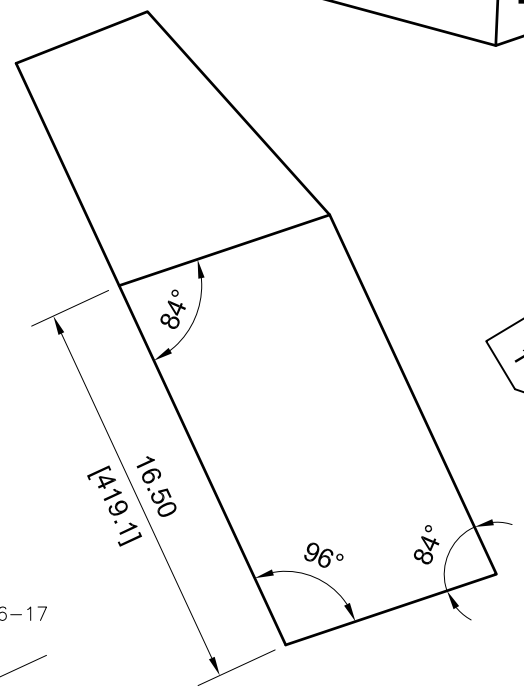
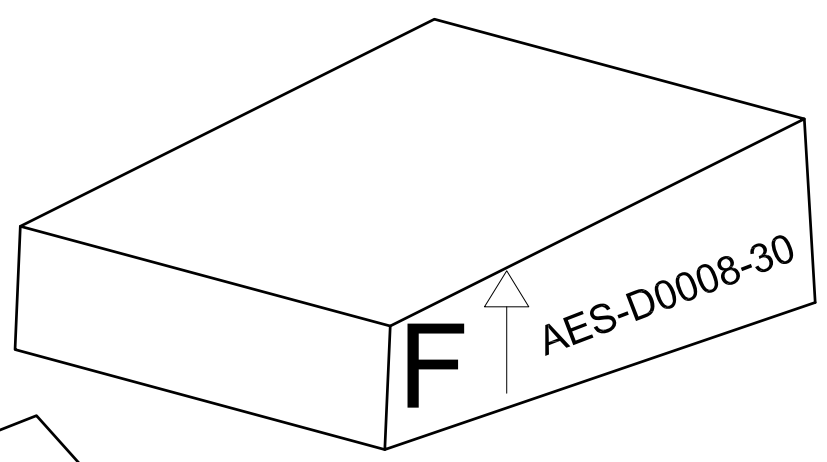
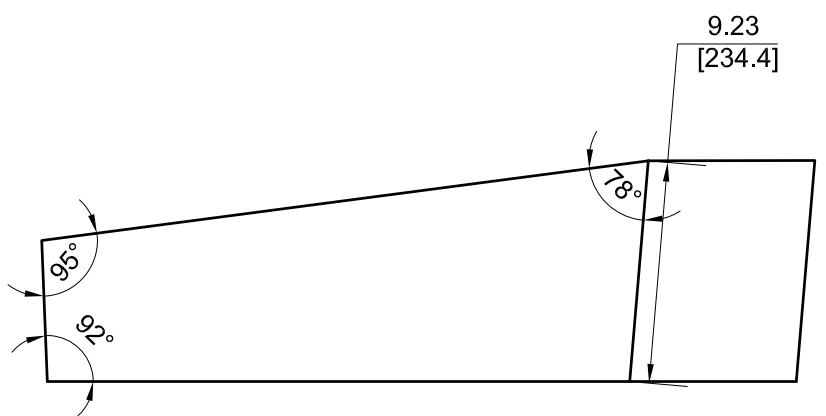

END

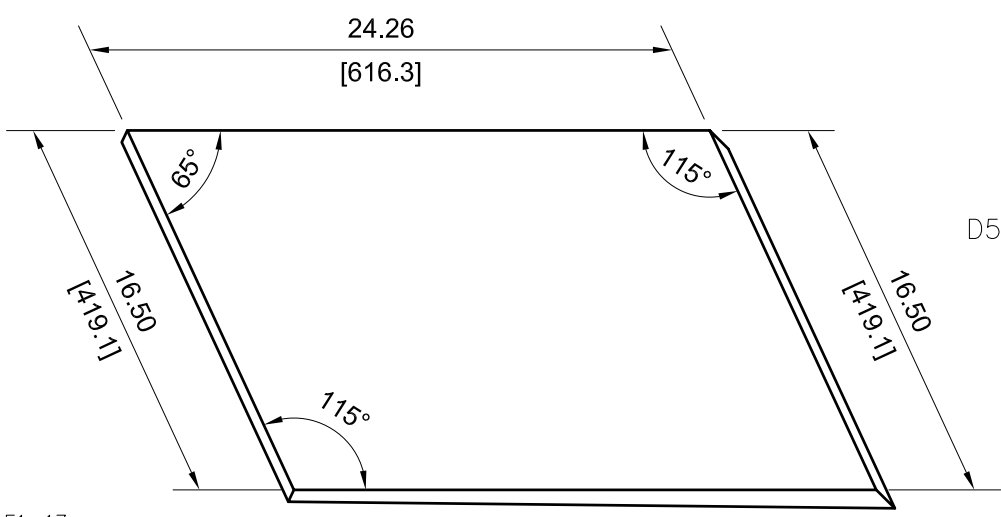

D5-17 D6-17

VIEW D5-17

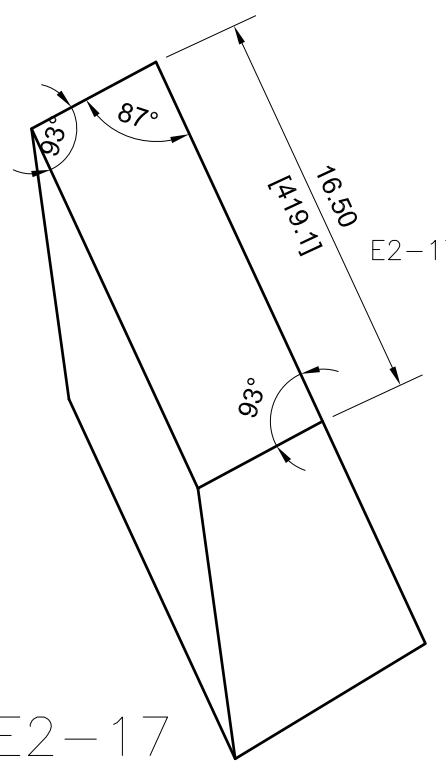

E2-17 F1-17

VIEW E2-17

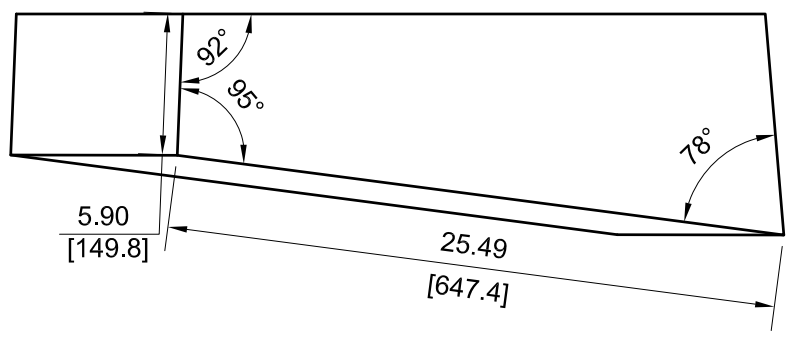

UP

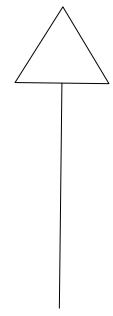

DRAWING NUMBER					AES-D0008				
SIZE	SCALE	SHEET	OF	REVISION					
A3	NONE	17	190	B					

— 32

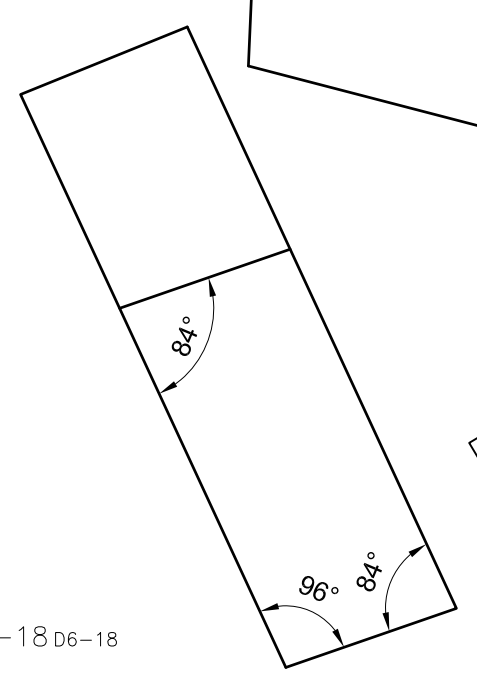
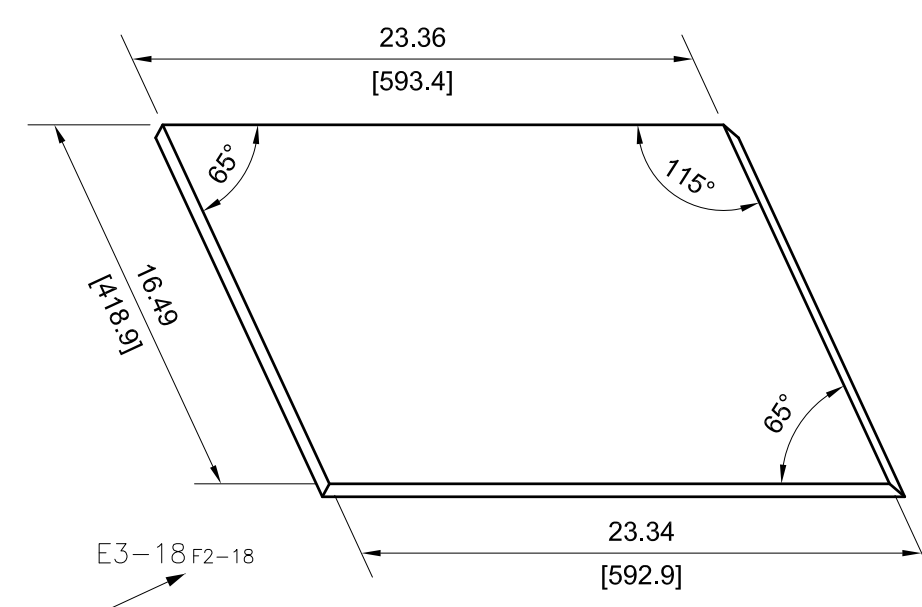
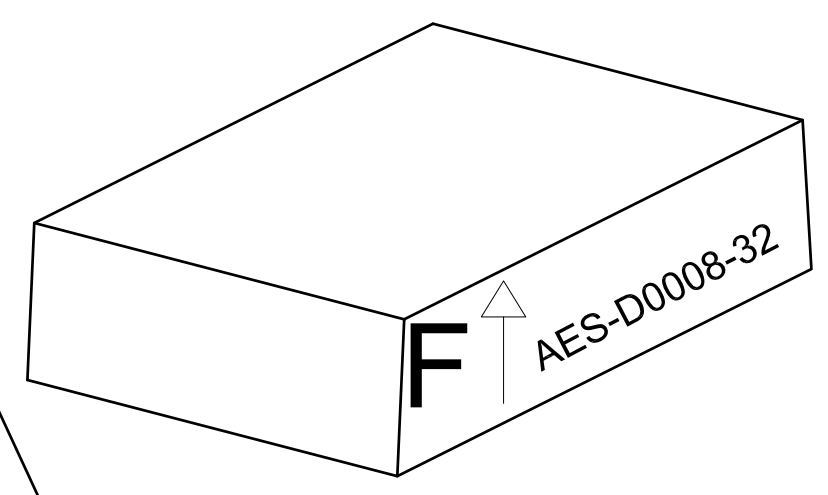

VIEW D5-18

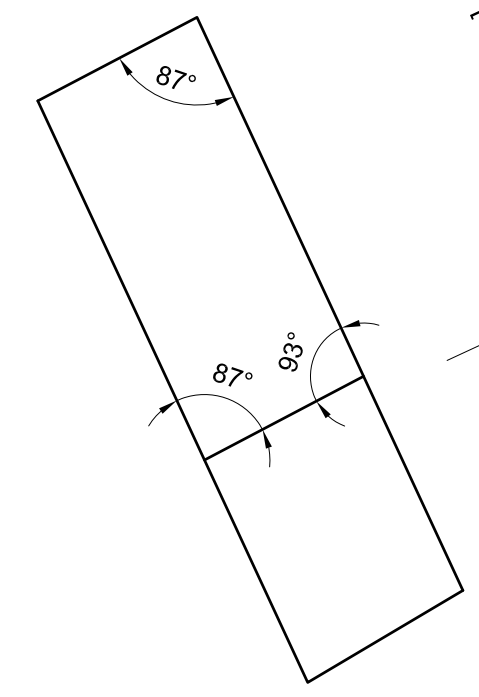

VIEW E3-18

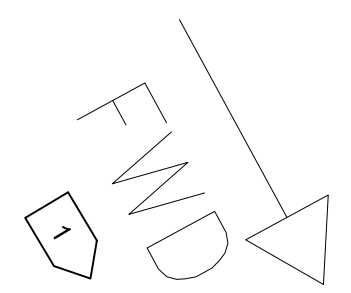
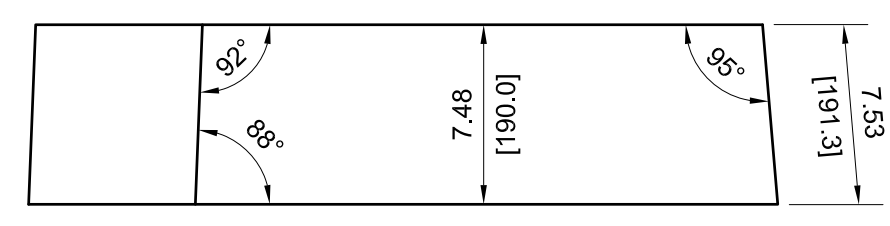

DRAWING NUMBER				
AES-D0008				
SIZE	SCALE	SHEET	OF	REVISION
A3	NONE	18	190	B

34

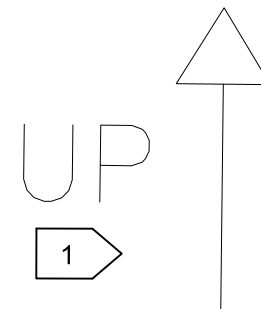
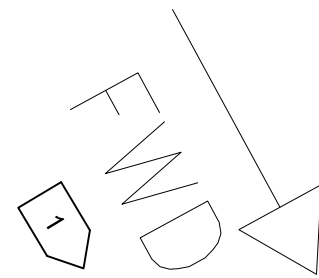
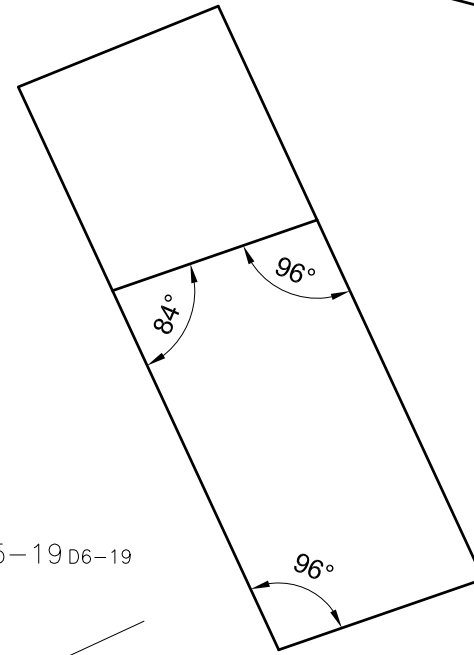
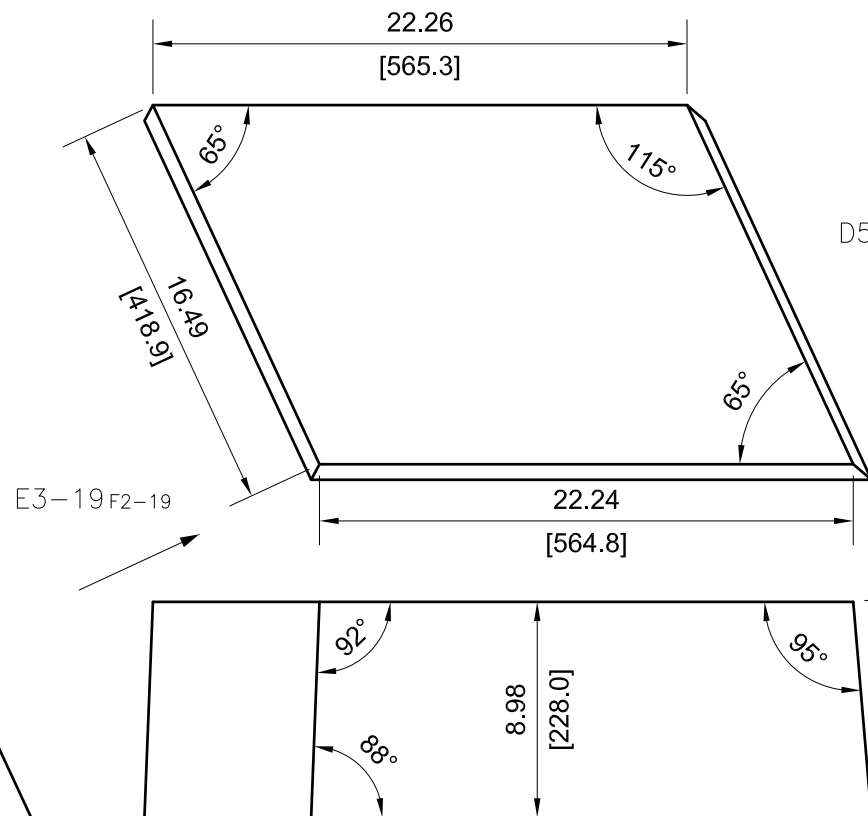
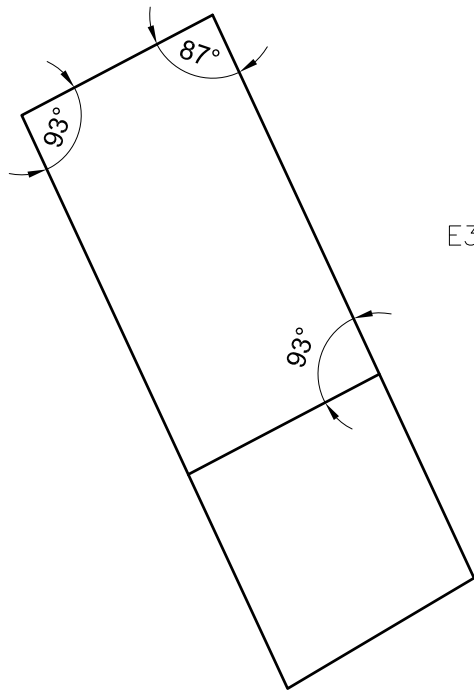
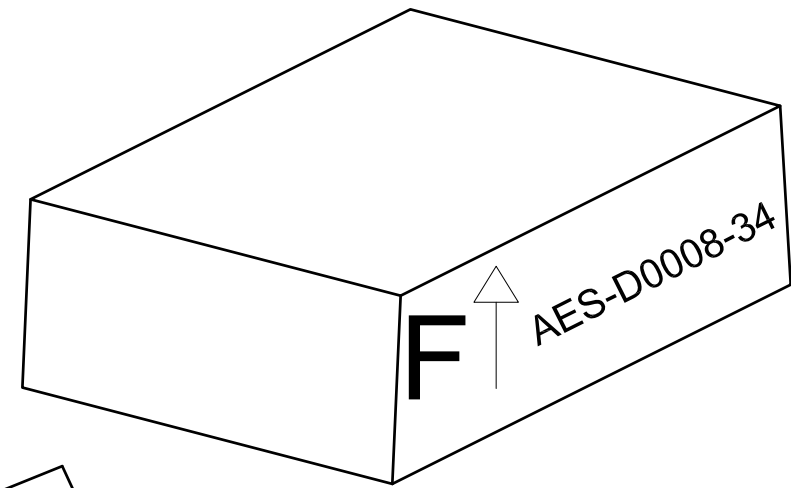

VIEW E3-19

VIEW D5-19



DRAWING NUMBER					AES-D0008	
SIZE	SCALE	SHEET	OF	REVISION		
A3	NONE	19	190	B		

36

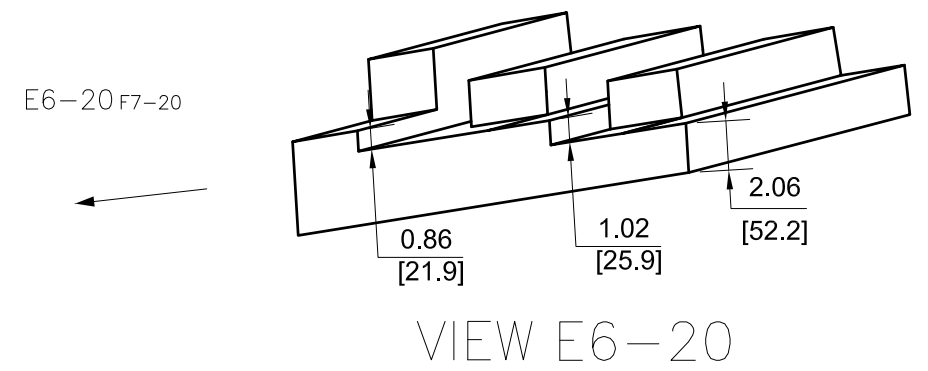
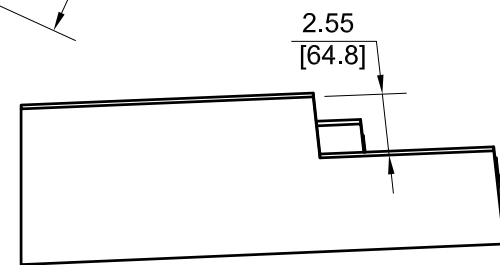
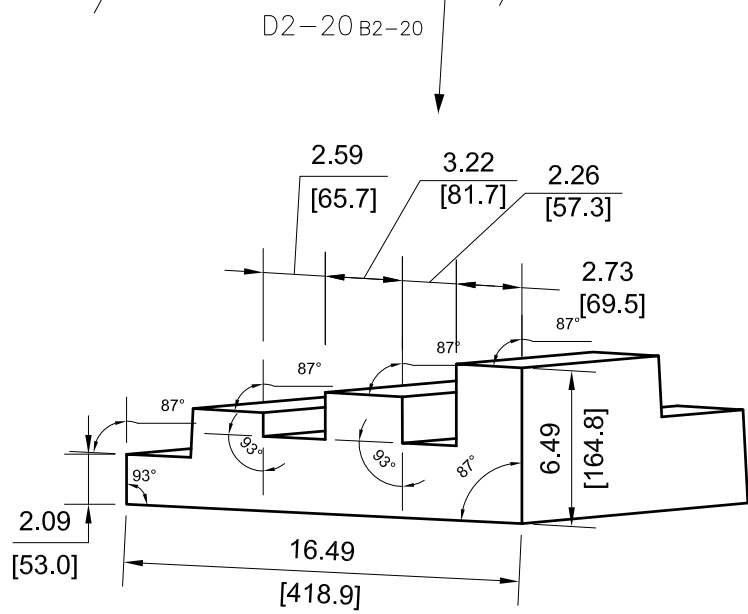
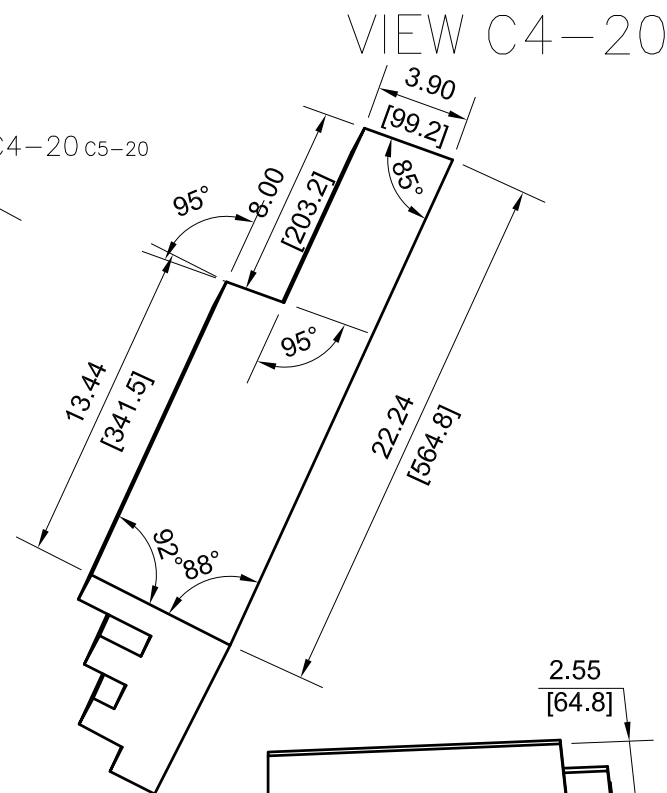
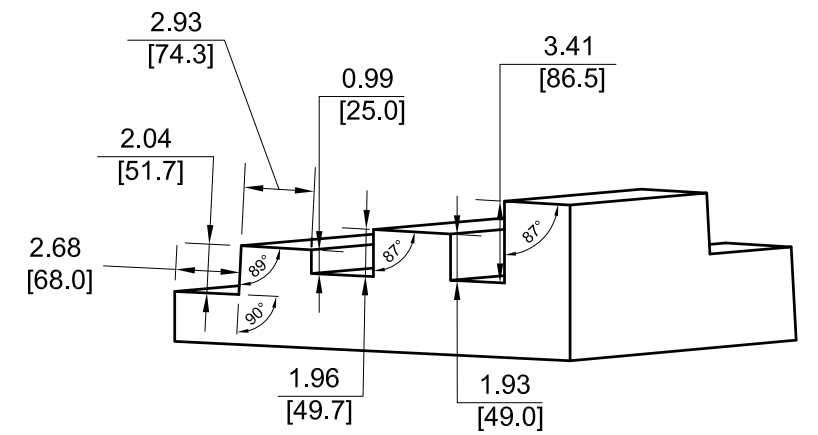
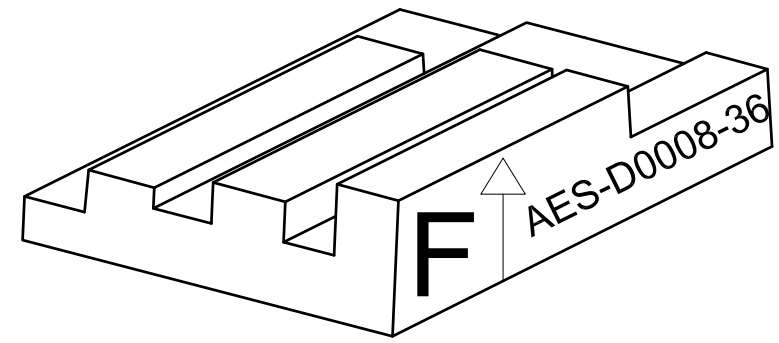
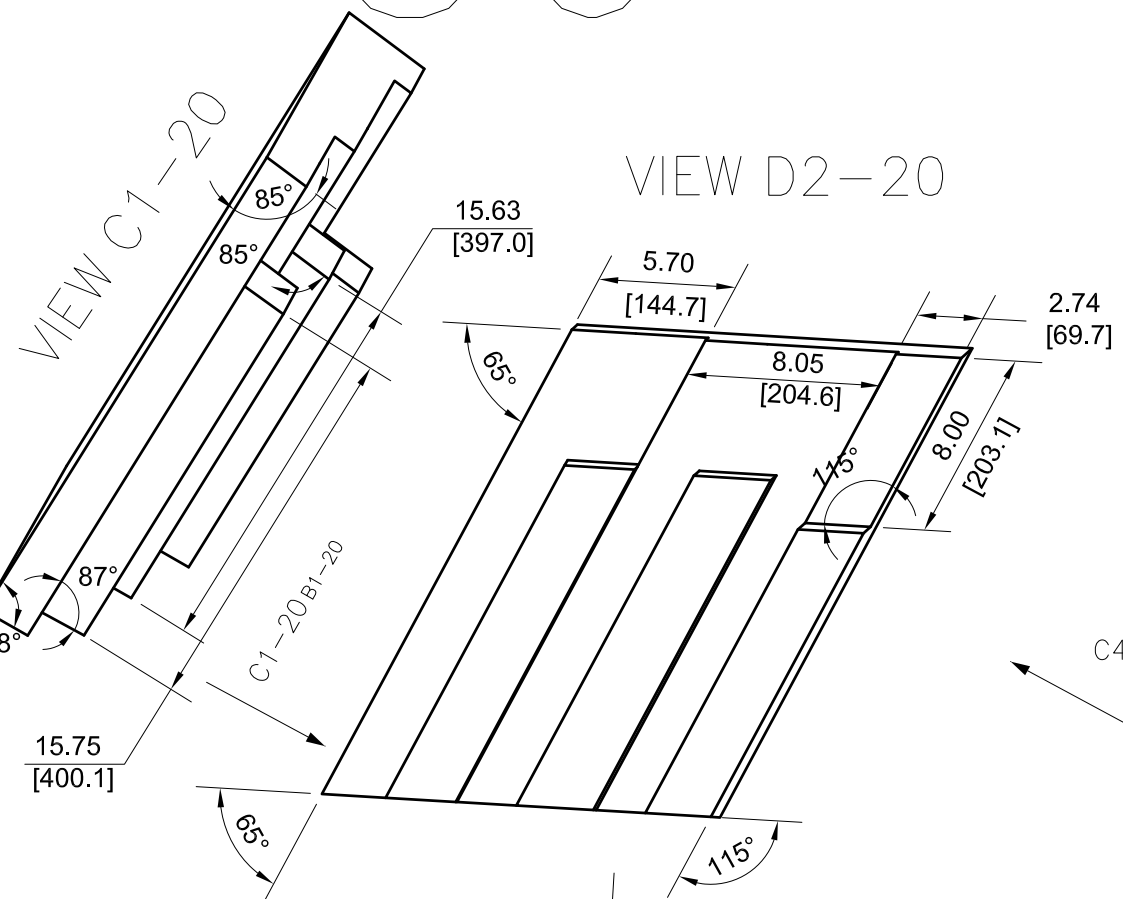

DRAWING NUMBER				
AES-D0008				
SIZE	SCALE	SHEET	OF	REVISION
A3	NONE	20	190	B

38

SECTION VIEW D4-21

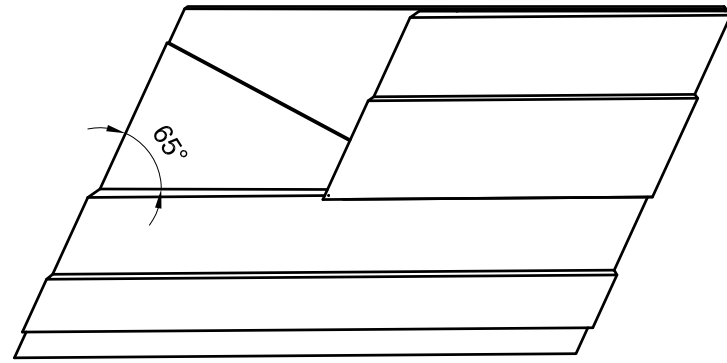

REAR VIEW RELATIVE TO VIEW D5-21

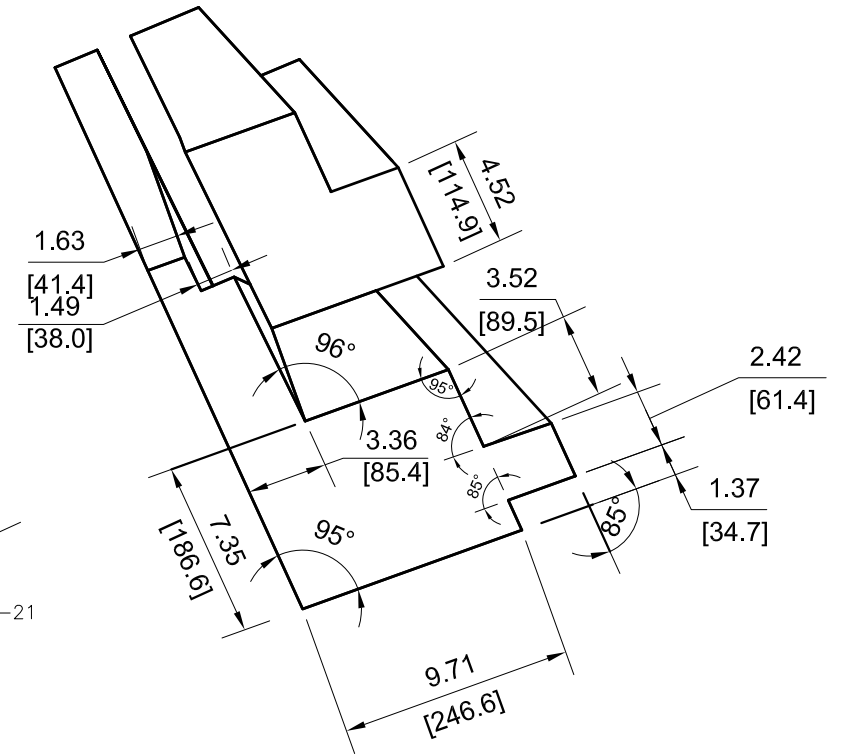
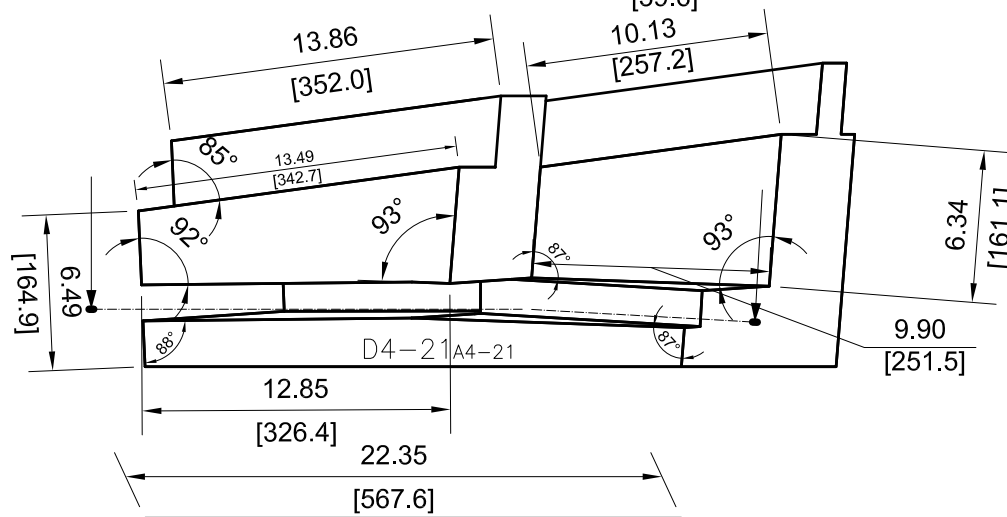
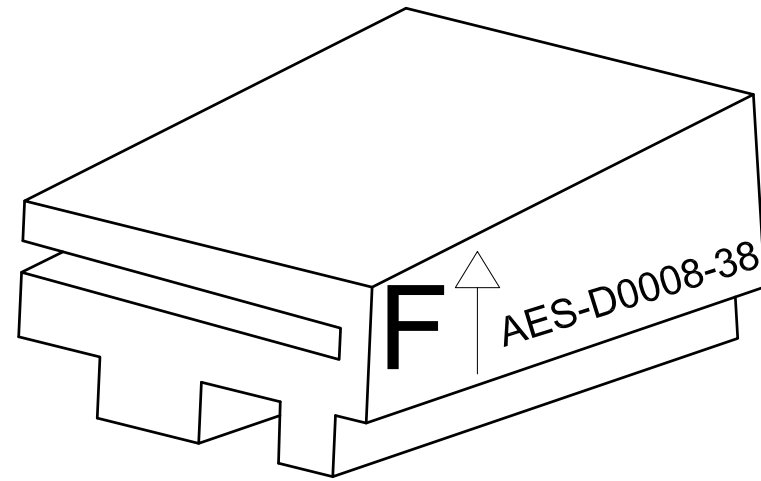
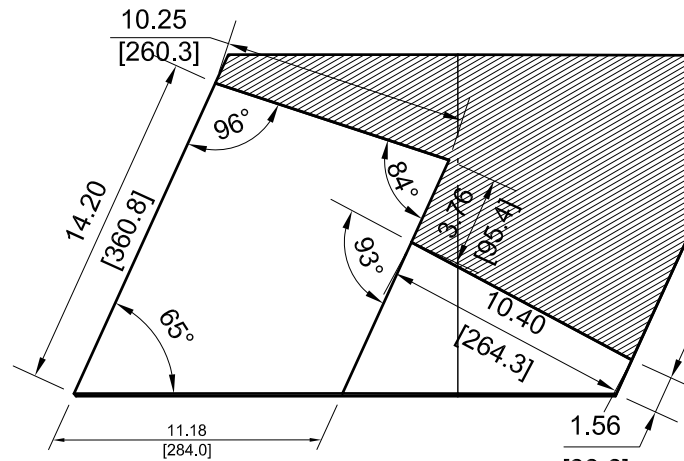

VIEW E3-21

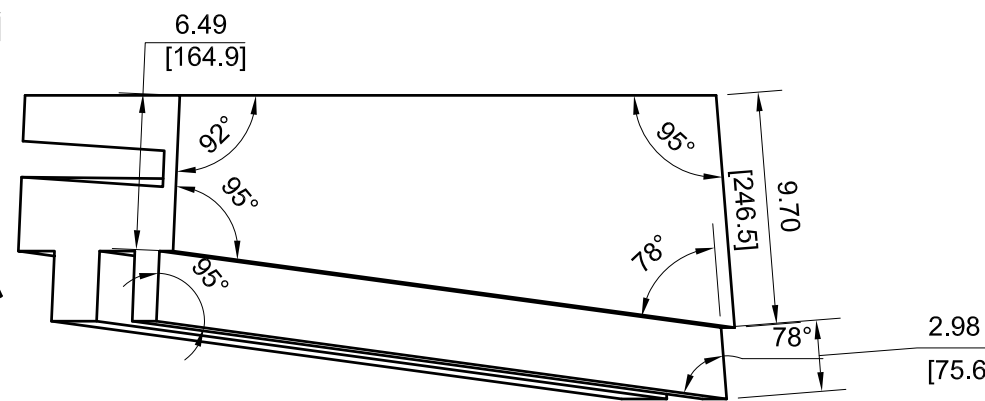
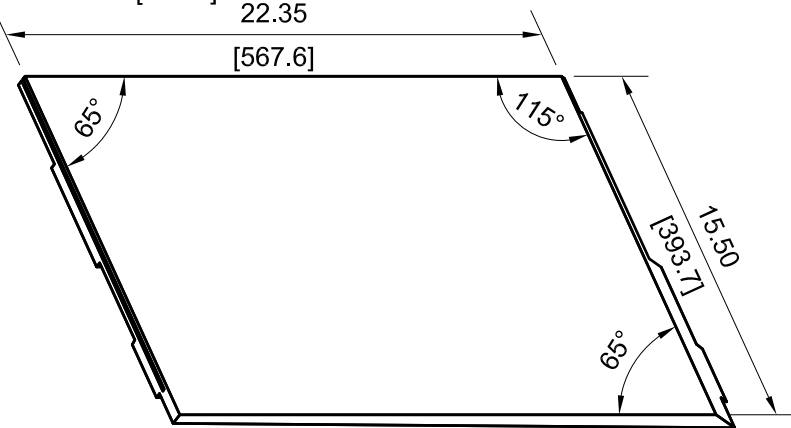
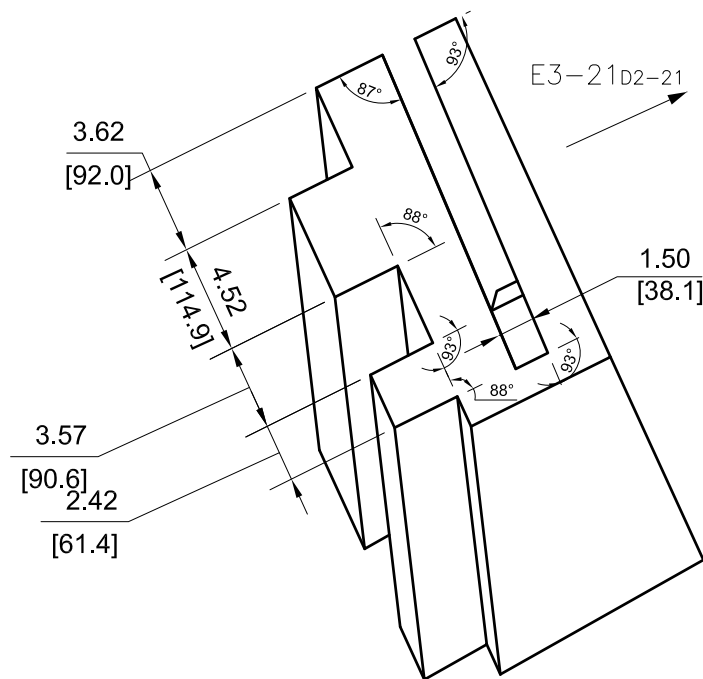

VIEW D6-21

	DRAWING NUMBER				
	AES-D0008				
SIZE	SCALE	SHEET	OF	REVISION	
A3	NONE	21	190	B	

— 40

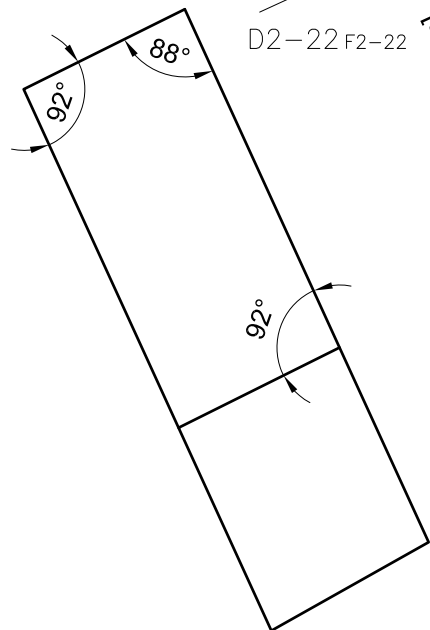
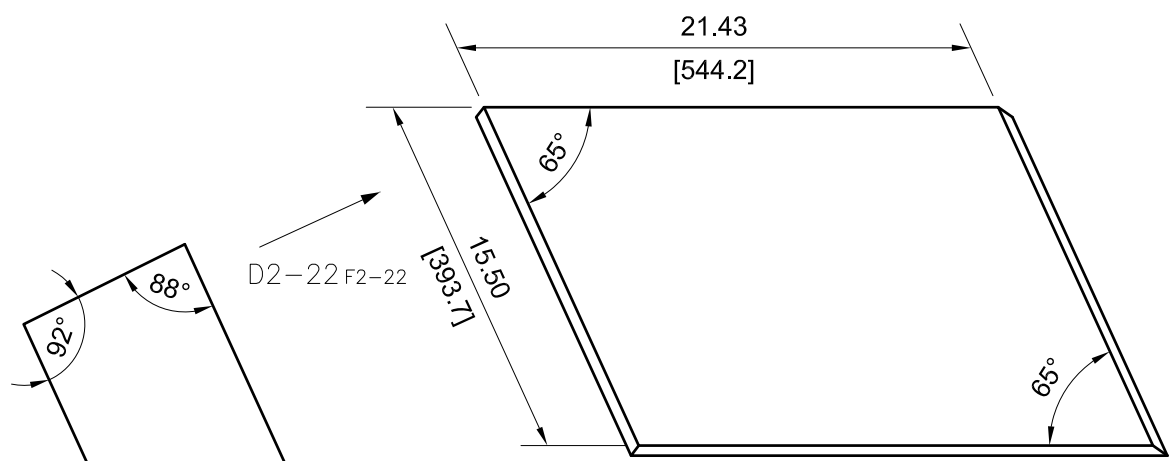
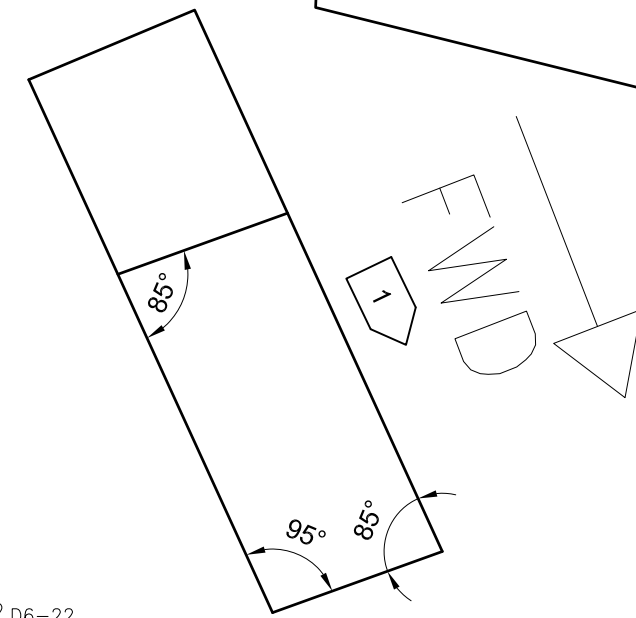
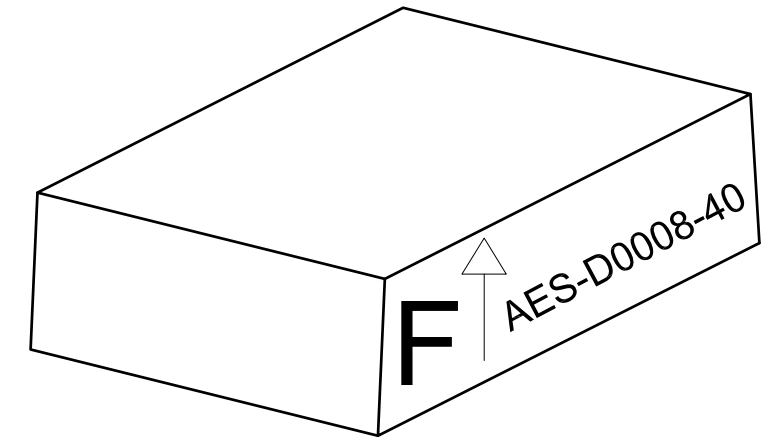

VIEW D2-22

D5-22 D6-22

VIEW D5-22



DRAWING NUMBER					AES-D0008				
SIZE	SCALE	SHEET	OF	REVISION					
A3	NONE	22	190	B					

42

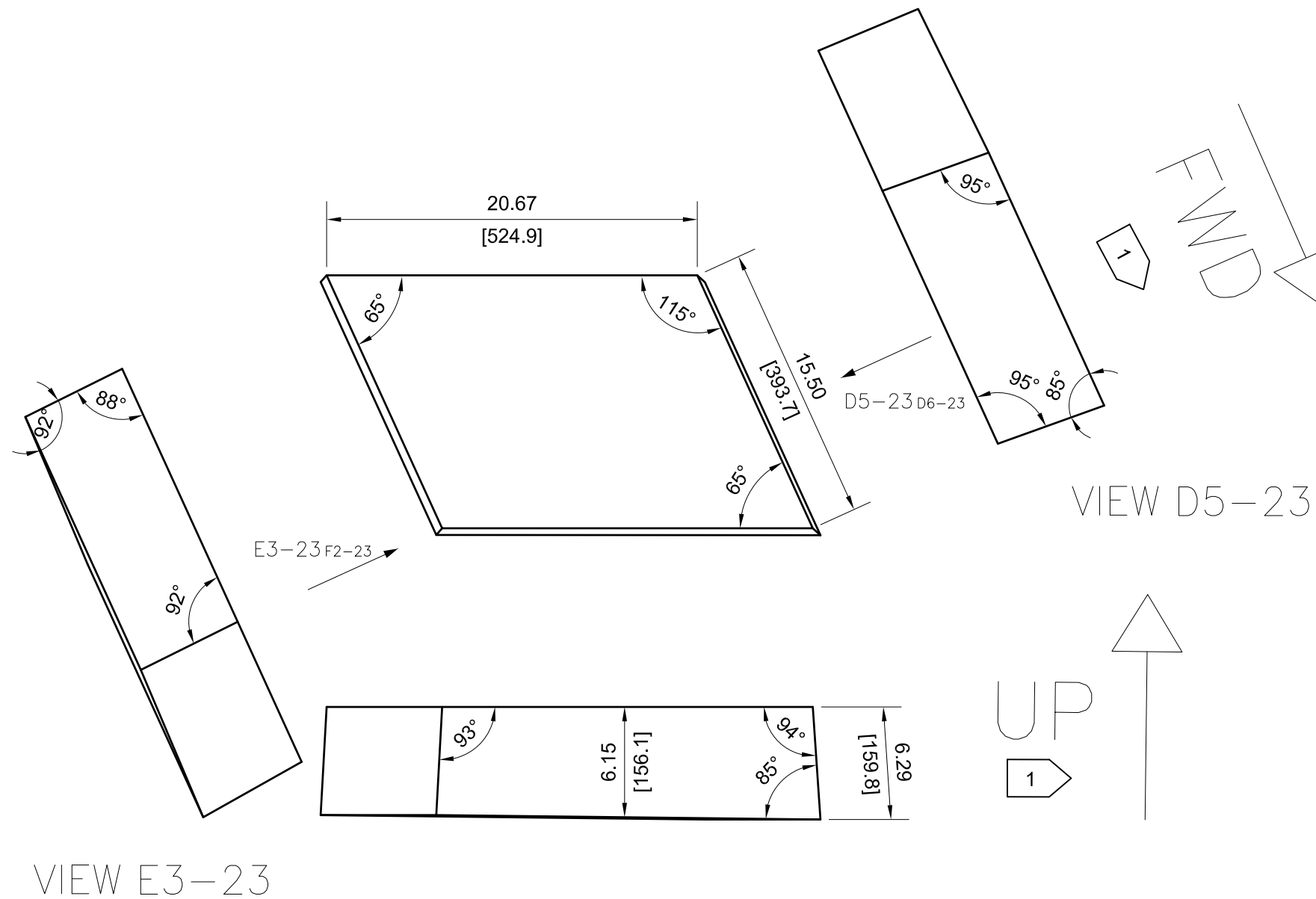
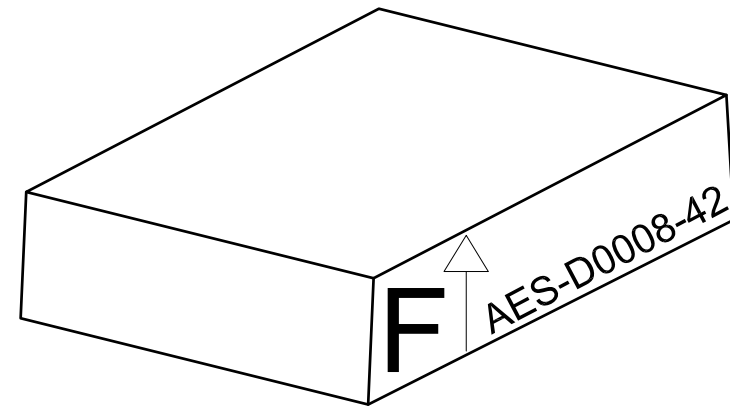

DRAWING NUMBER				
AES-D0008				
SIZE	SCALE	SHEET	OF	REVISION
A3	NONE	23	190	B

1 2 3 4 5 6 7 8

A

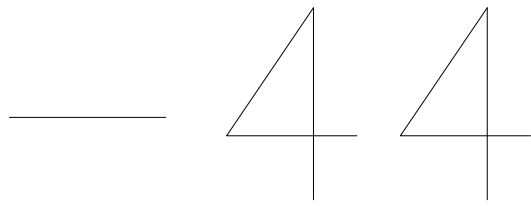

B

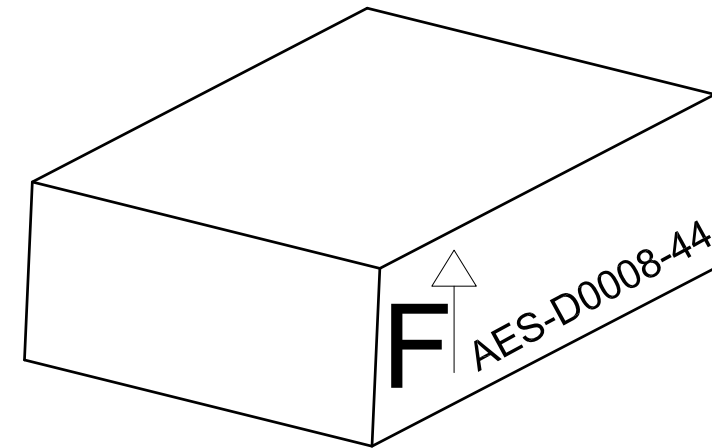

C

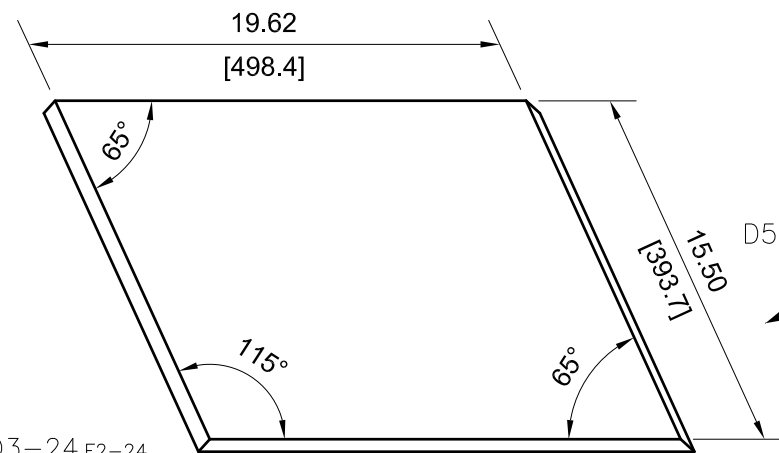

D5-24 D6-24

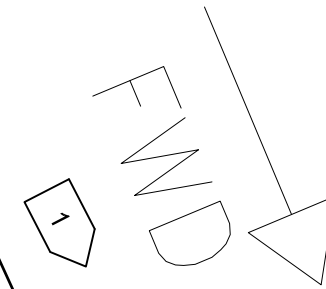

VIEW D5-24

D

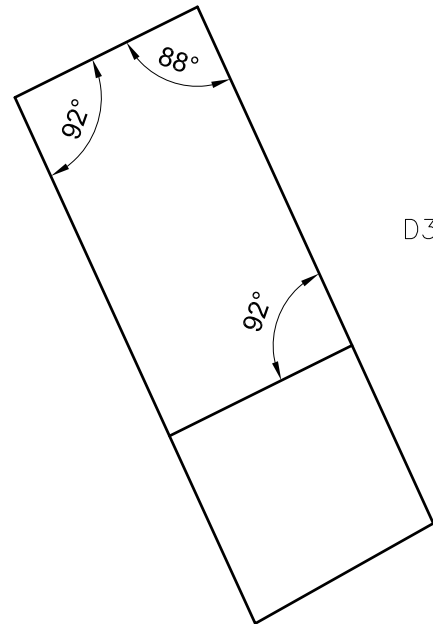

VIEW D3-24

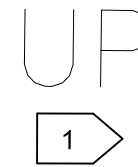
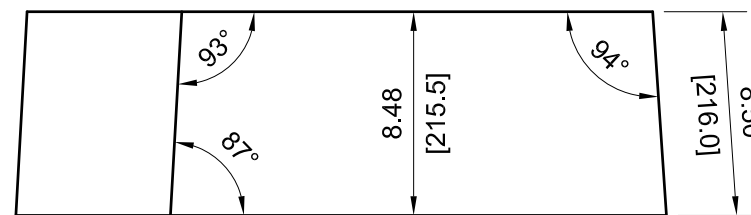

E

F

1 2 3 4 5 6 7 8



DRAWING NUMBER					AES-D0008	
SIZE	SCALE	SHEET	OF	REVISION		
A3	NONE	24	190	B		

46

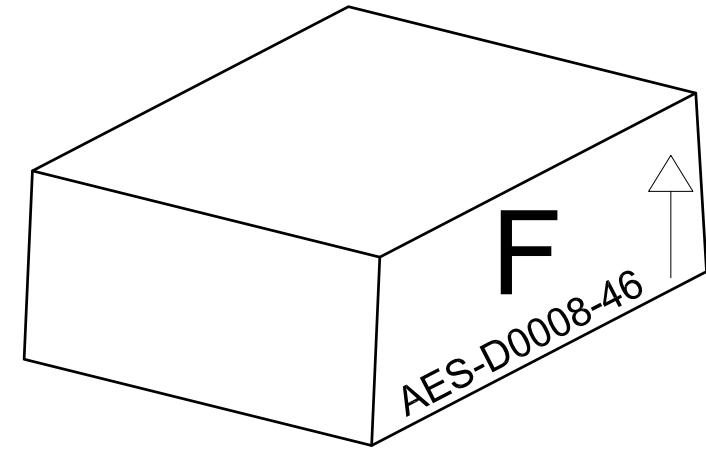

VIEW E3-25

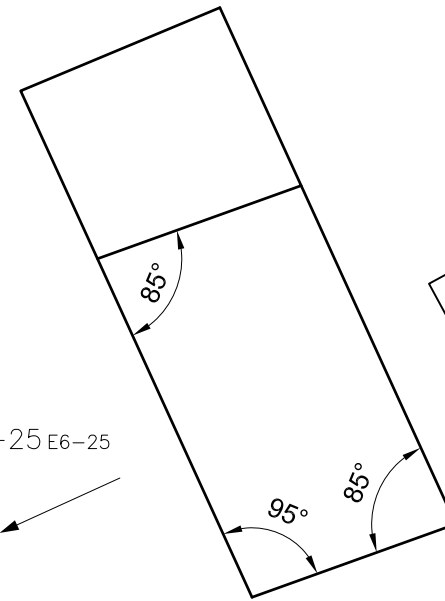
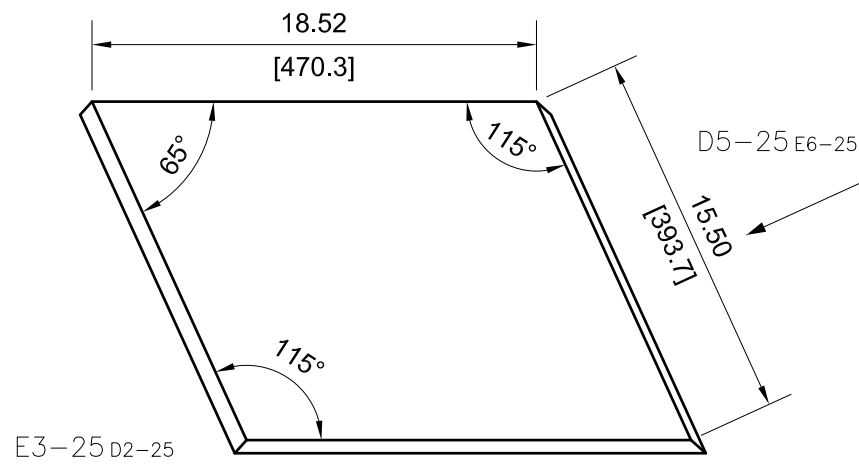
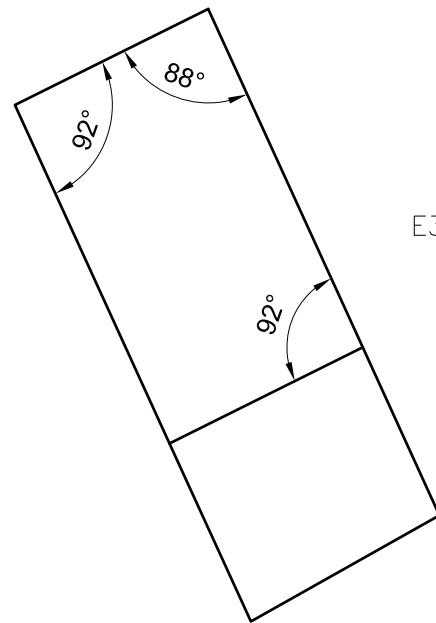

VIEW D5-25

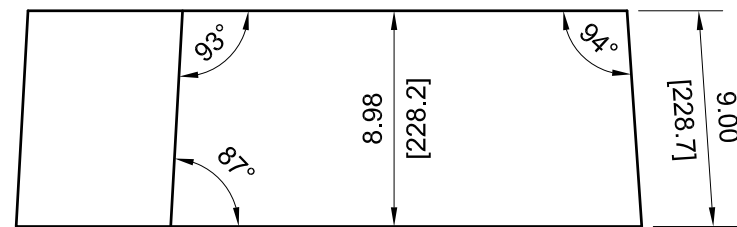

END



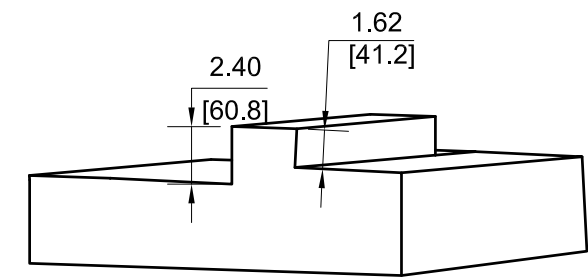
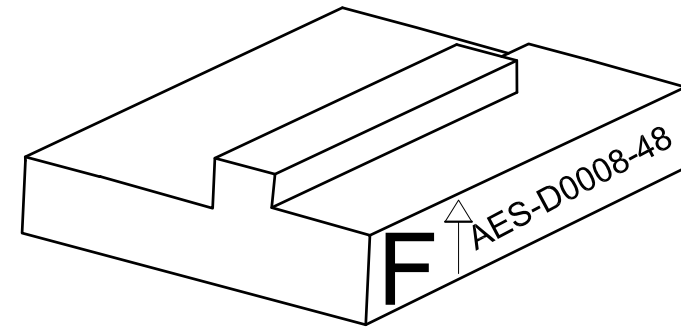
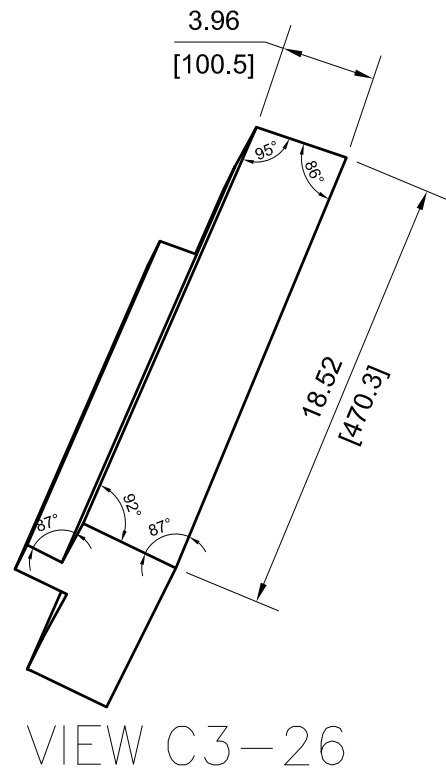
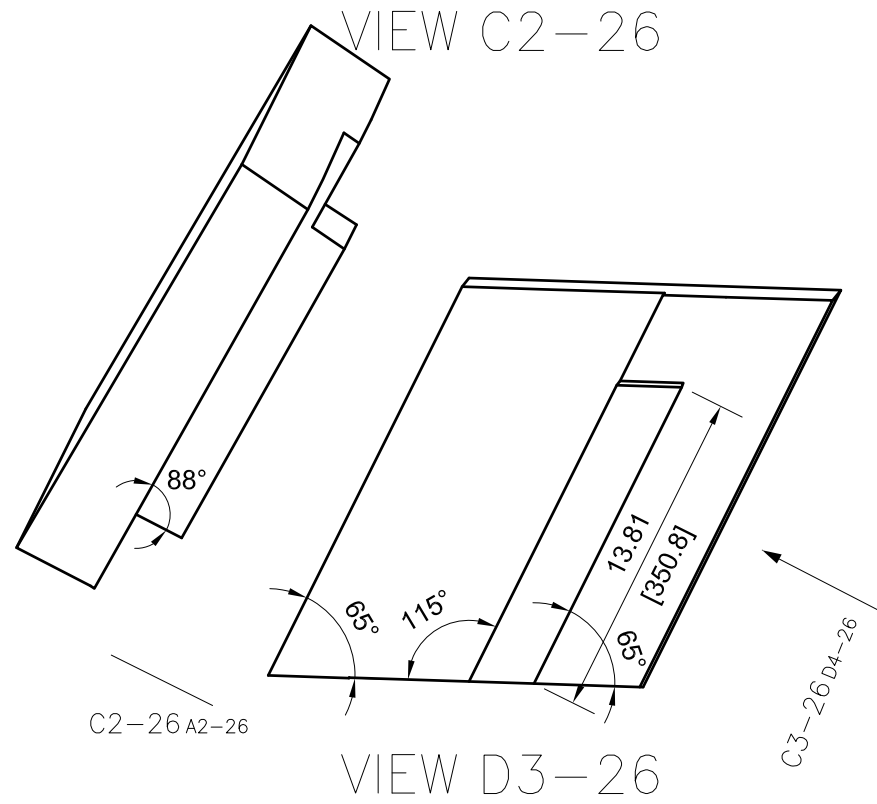

DRAWING NUMBER					AES-D0008	
SIZE	SCALE	SHEET	OF	REVISION		
A3	NONE	25	190	B		

48

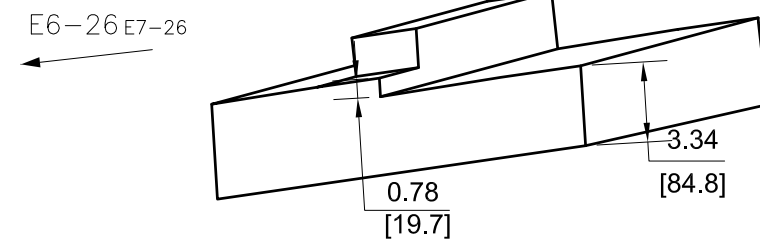
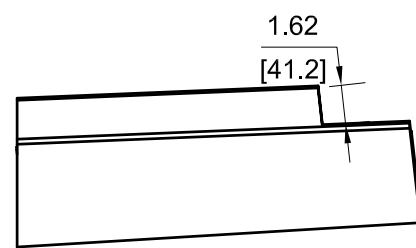
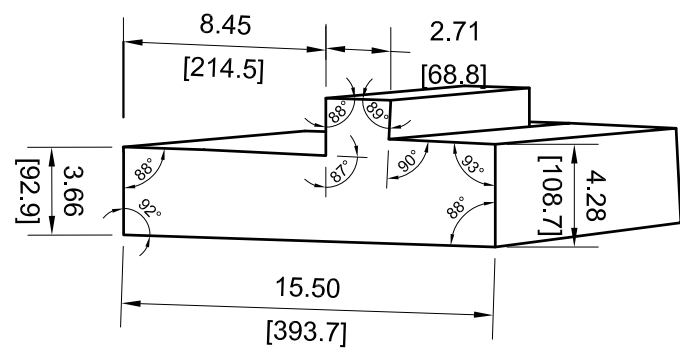

REPEATED VIEW F2-26 SHOWN FOR CLARITY PURPOSES



	DRAWING NUMBER				
	AES-D0008				
SIZE	SCALE	SHEET	OF	REVISION	
A3	NONE	26	190	B	

50

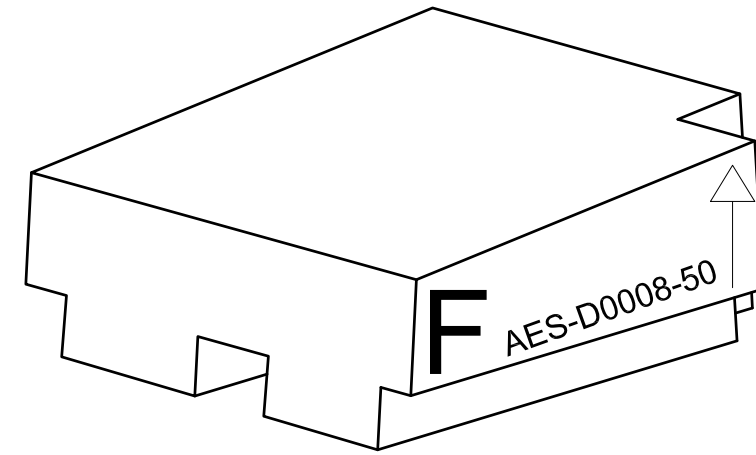
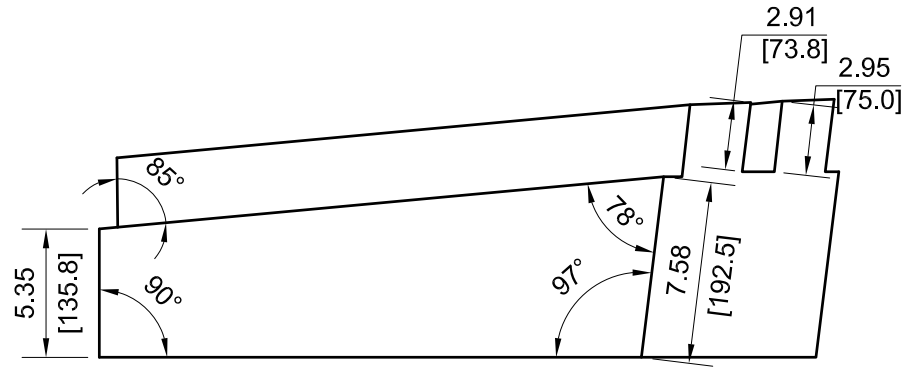

VIEW C3-27

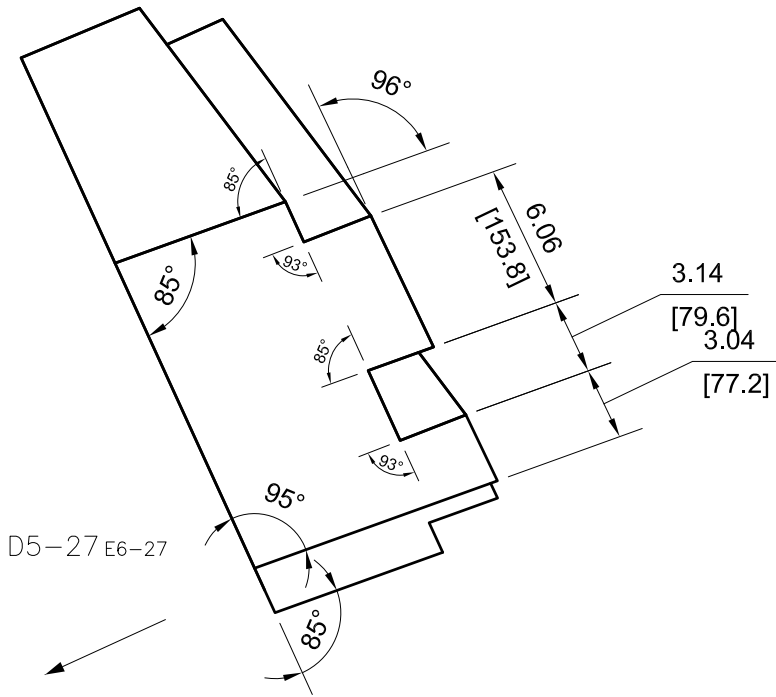
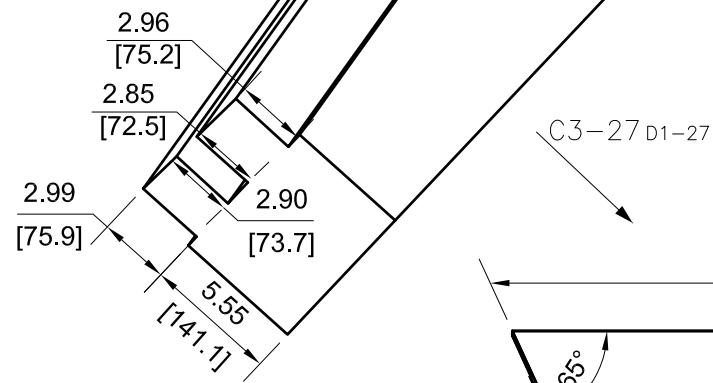

VIEW D5-27

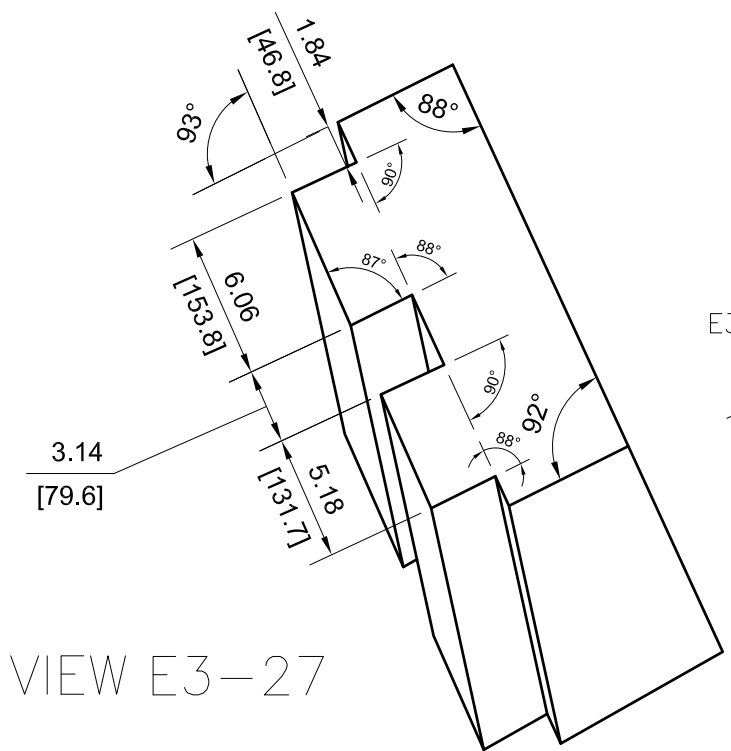
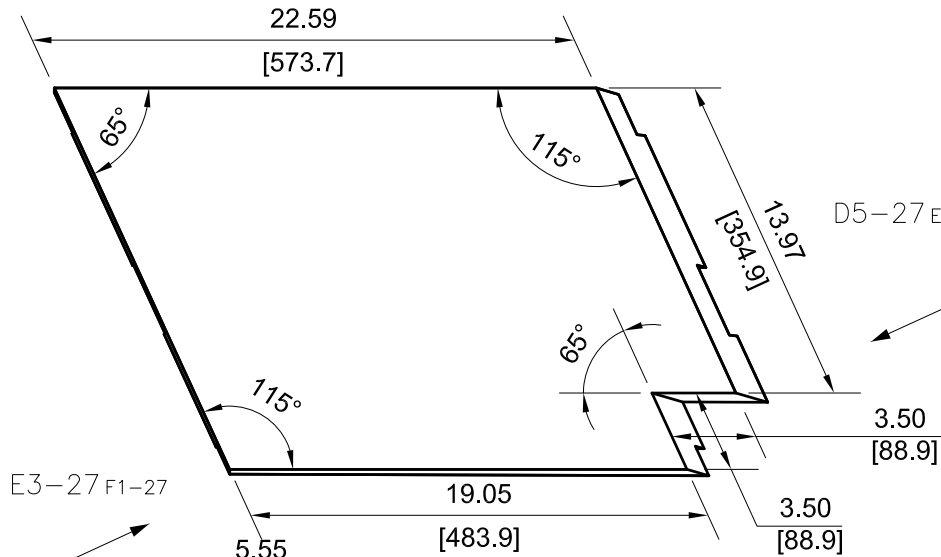

VIEW E3-27

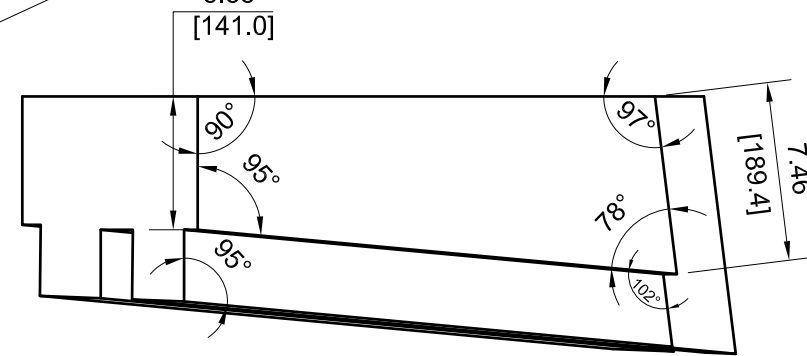

		DRAWING NUMBER			
		AES-D0008			
SIZE	SCALE	SHEET	OF	REVISION	
A3	NONE	27	190	B	

52

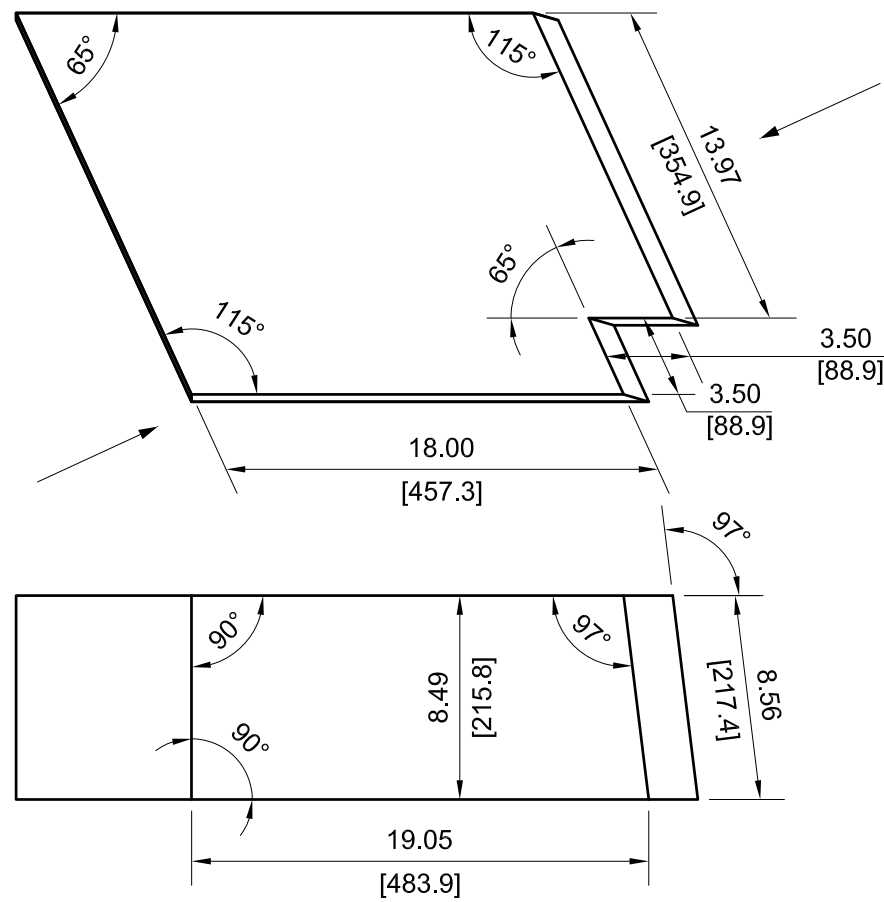
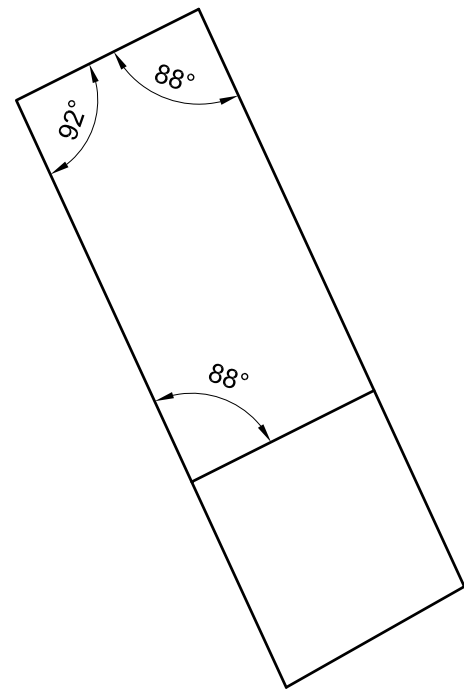
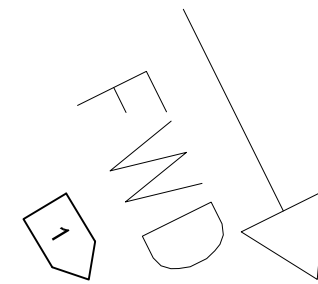
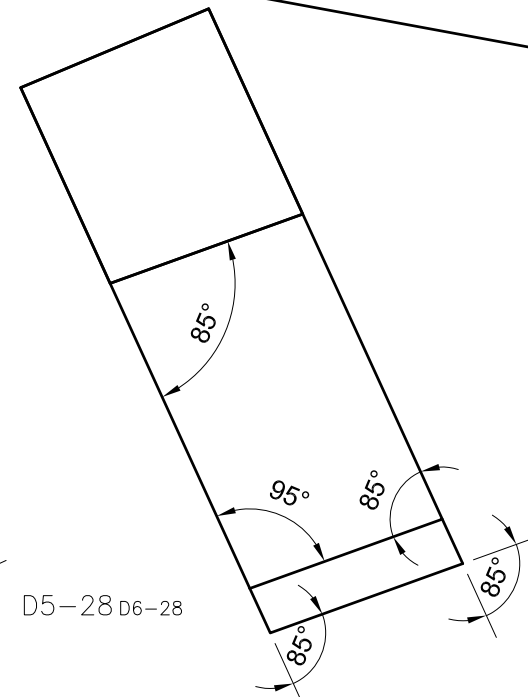
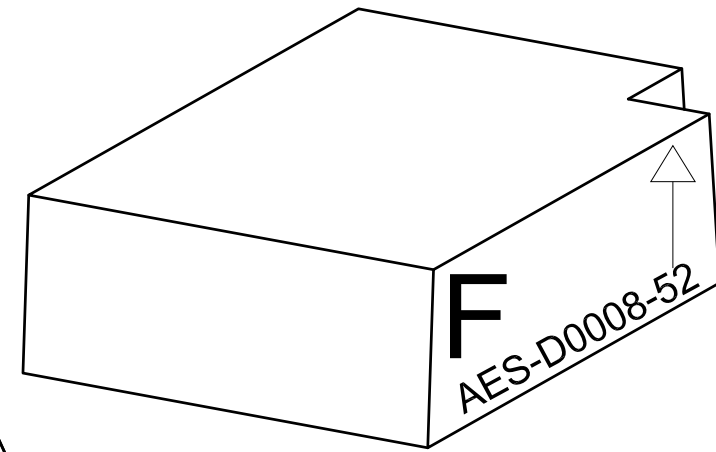

VIEW D5-28

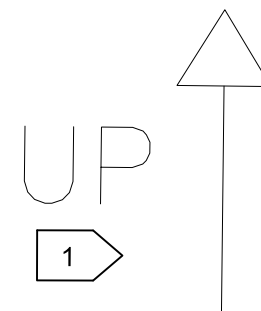

	DRAWING NUMBER				AES-D0008	
	SIZE	SCALE	SHEET	OF	REVISION	
A3	NONE	28	190	B		

54

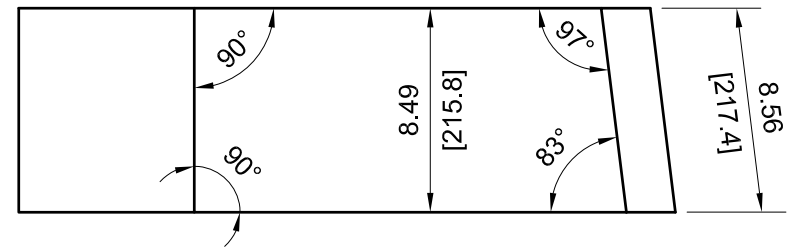
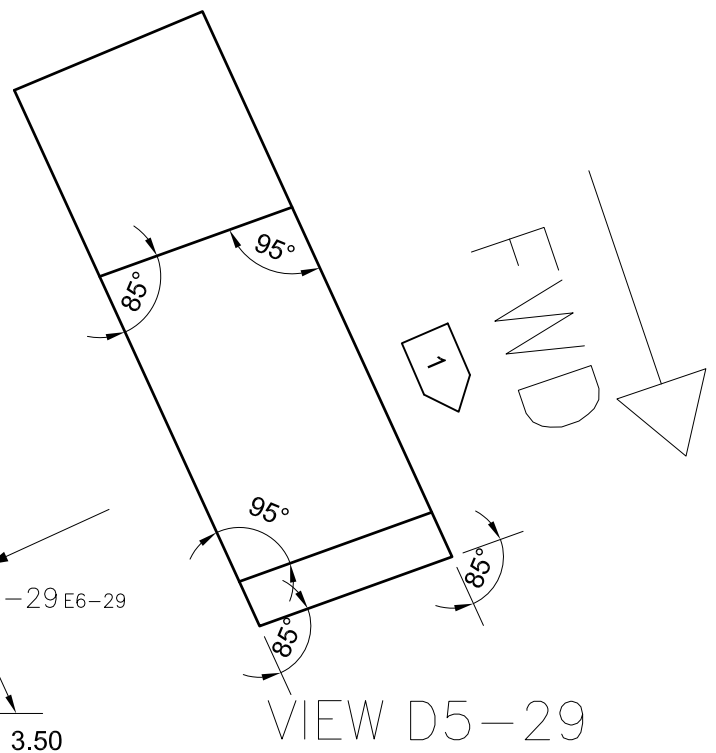
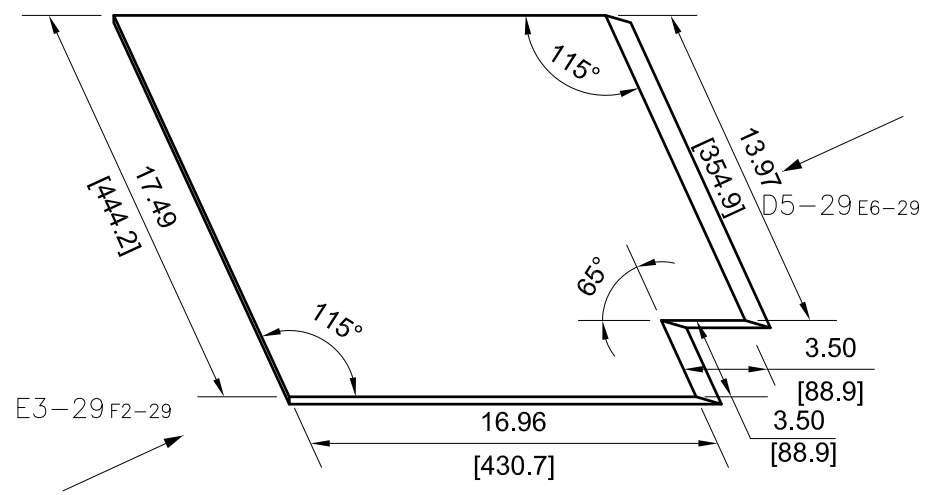
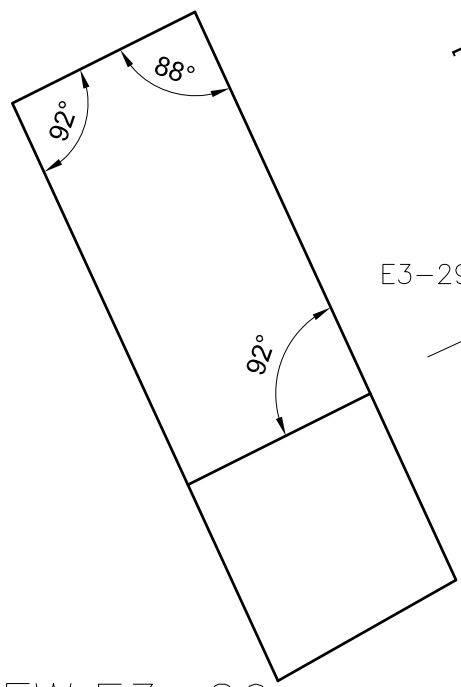
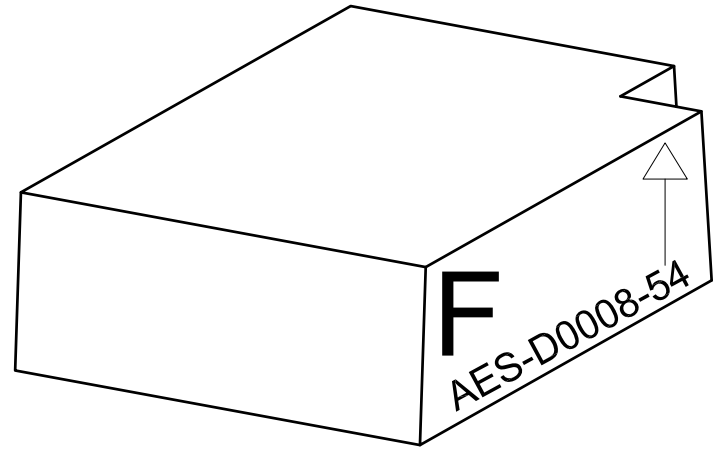

FIND

UP

VIEW E3-29

VIEW D5-29



DRAWING NUMBER				
AES-D0008				
SIZE	SCALE	SHEET	OF	REVISION
A3	NONE	29	190	B

56

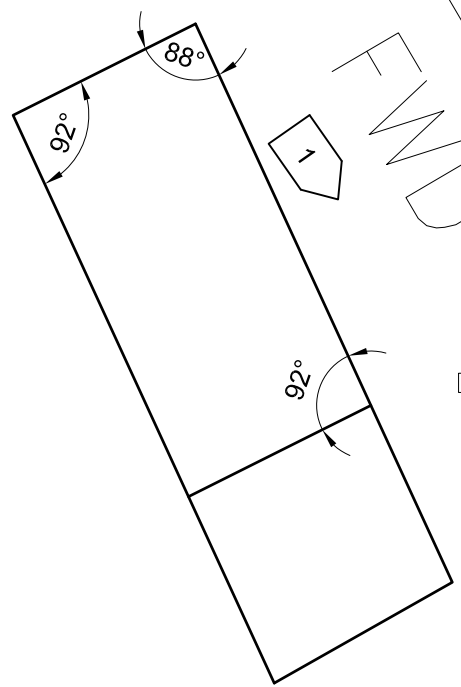
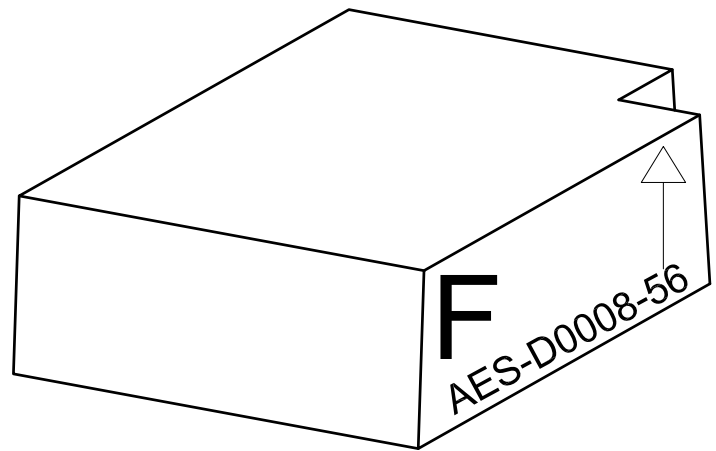

VIEW D3-30

FIND

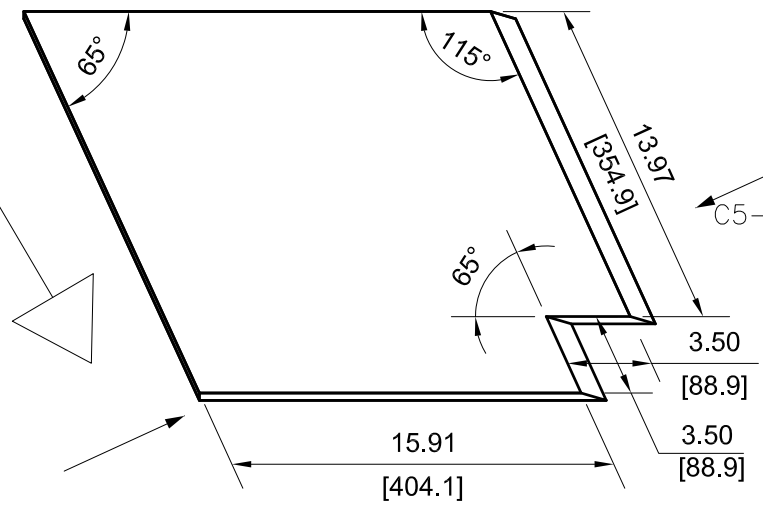

D3-30 E2-30

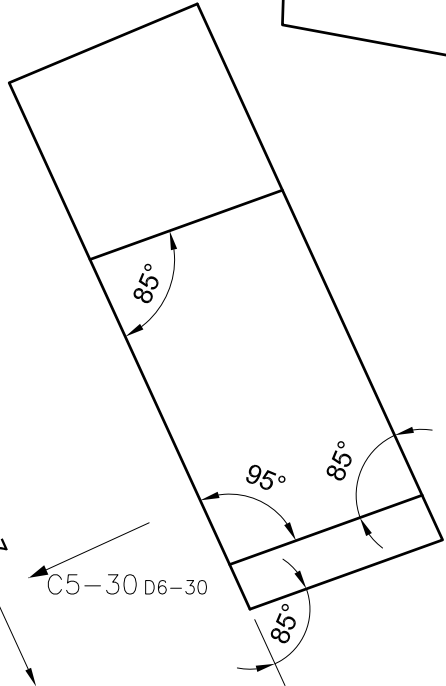

VIEW C5-30

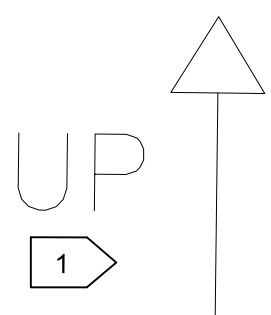
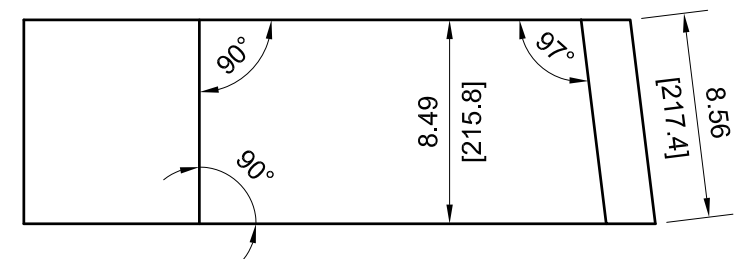

DRAWING NUMBER					AES-D0008	
SIZE	SCALE	SHEET	OF	REVISION		
A3	NONE	30	190	B		

58

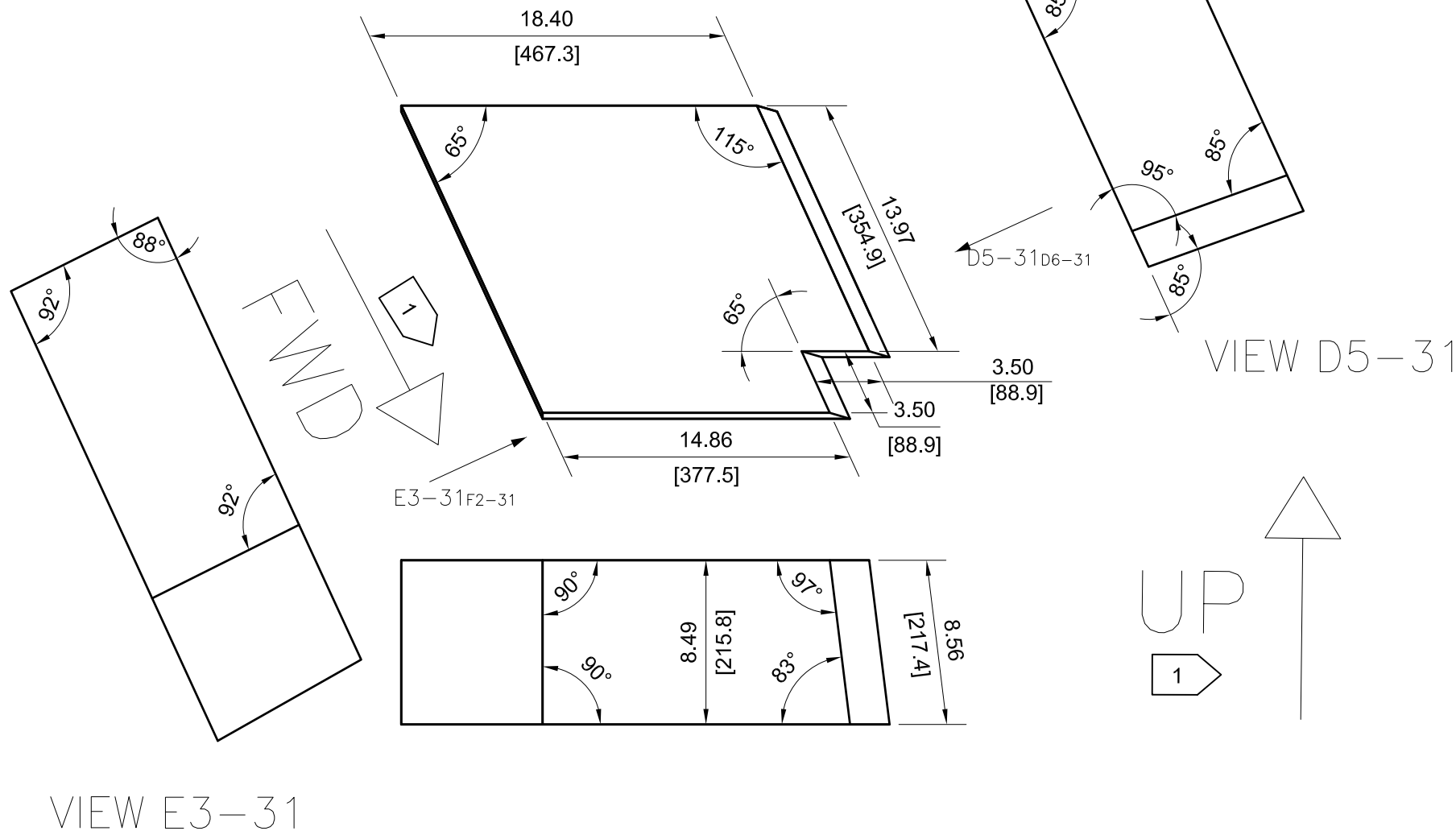
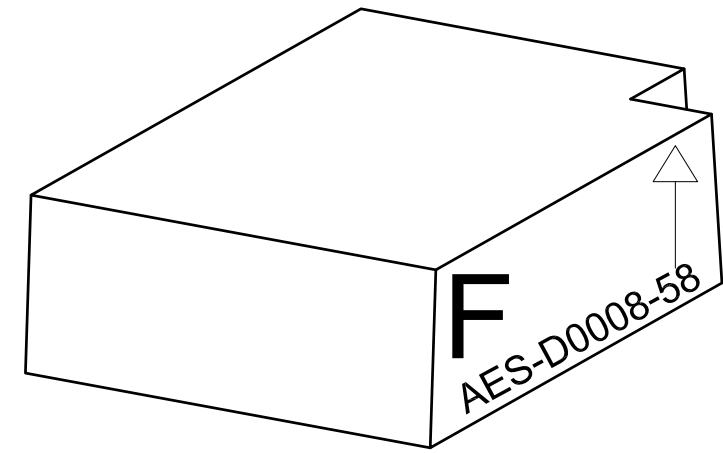

DRAWING NUMBER				
AES-D0008				
SIZE	SCALE	SHEET	OF	REVISION
A3	NONE	31	190	B

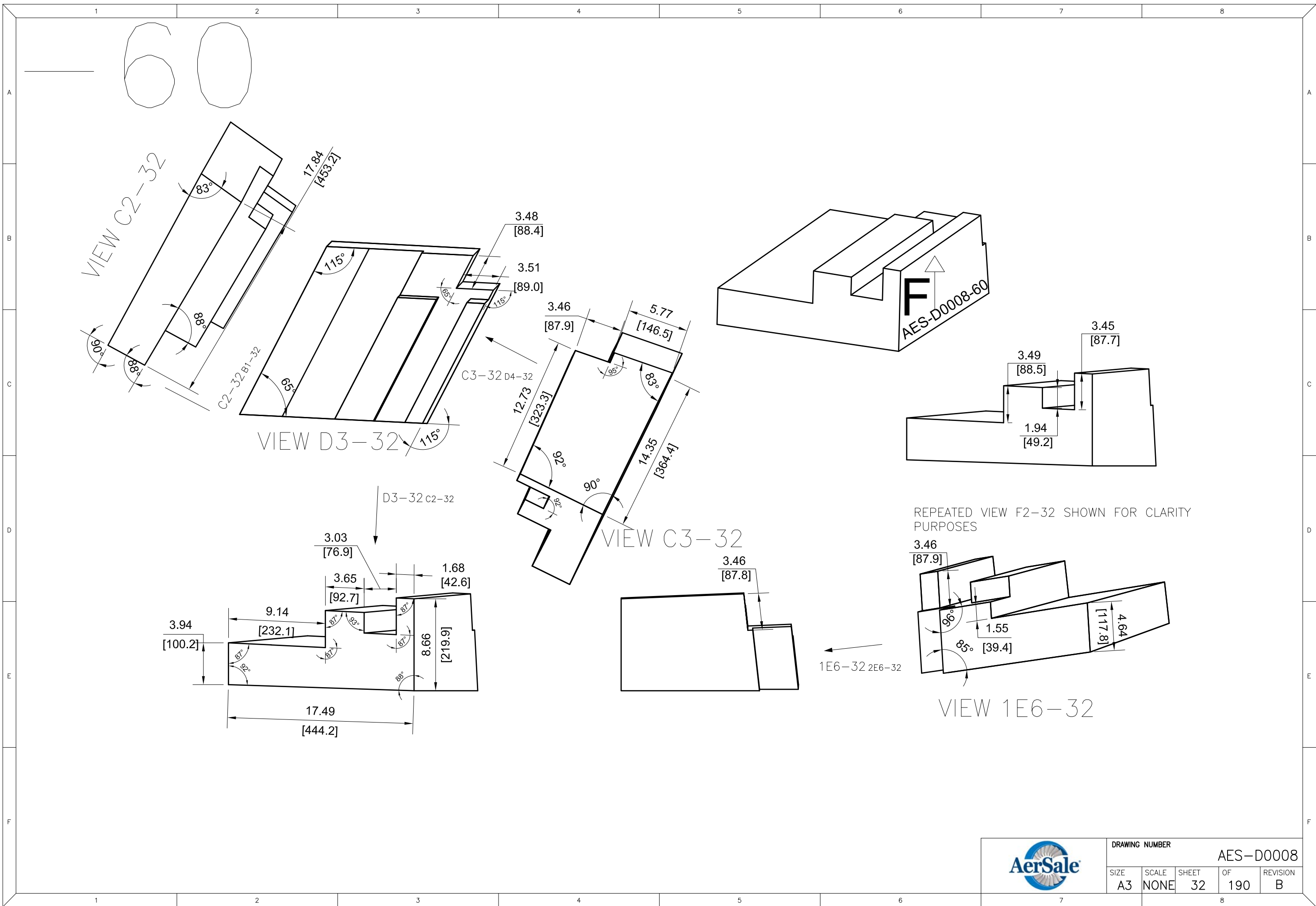

DRAWING NUMBER				
AES-D0008				
SIZE	SCALE	SHEET	OF	REVISION
A3	NONE	32	190	B

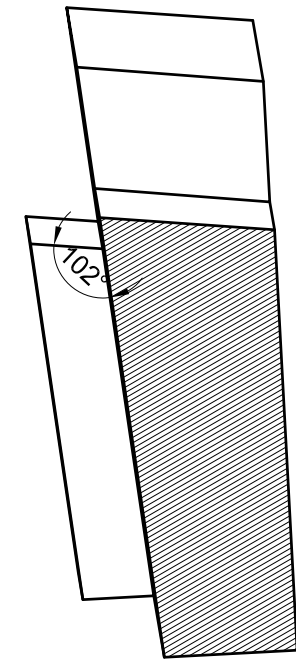

SECTION VIEW D2-33

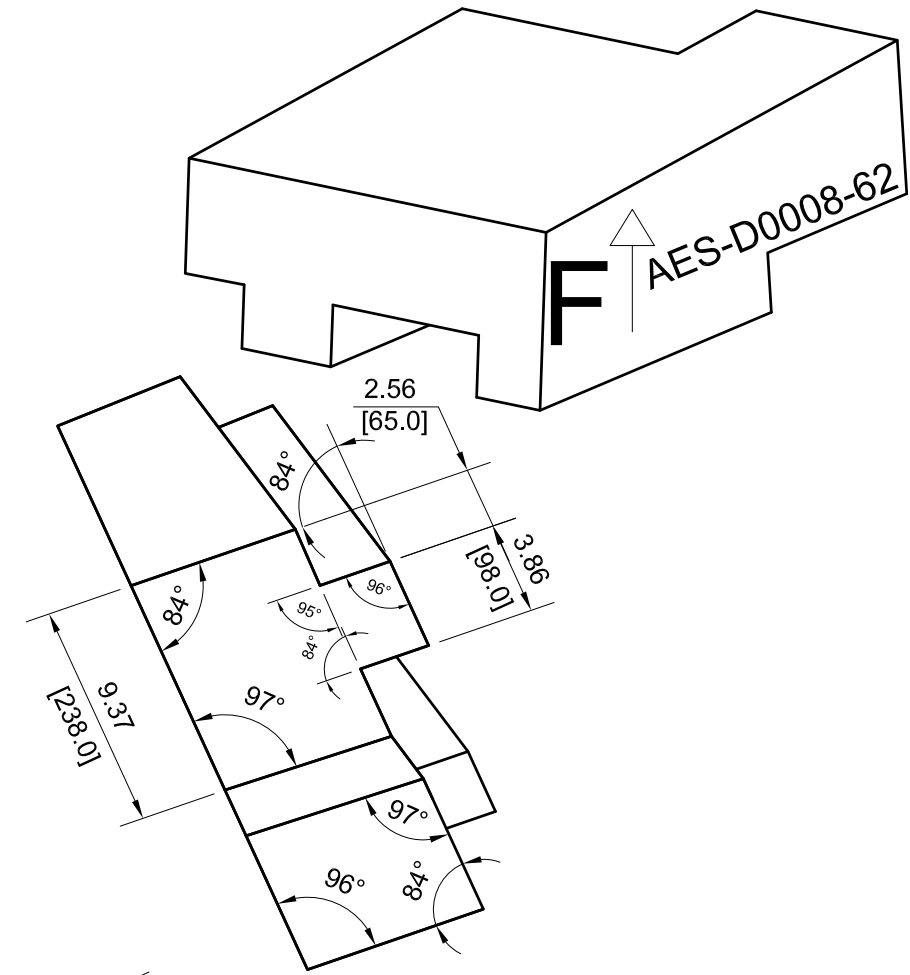
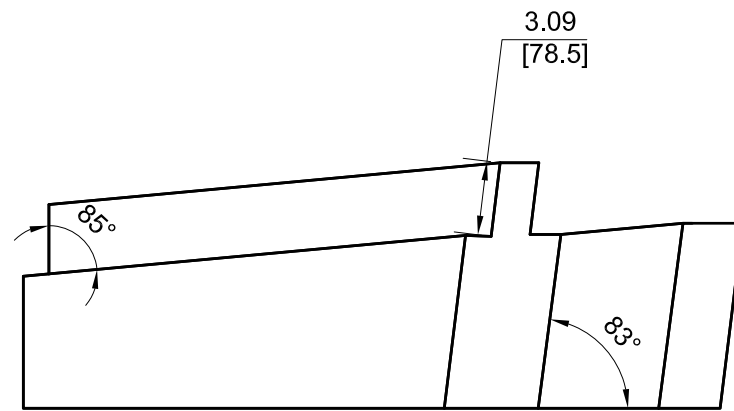
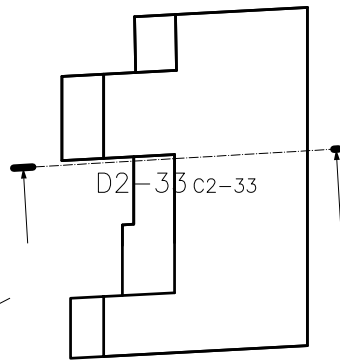

VIEW 1D6-33

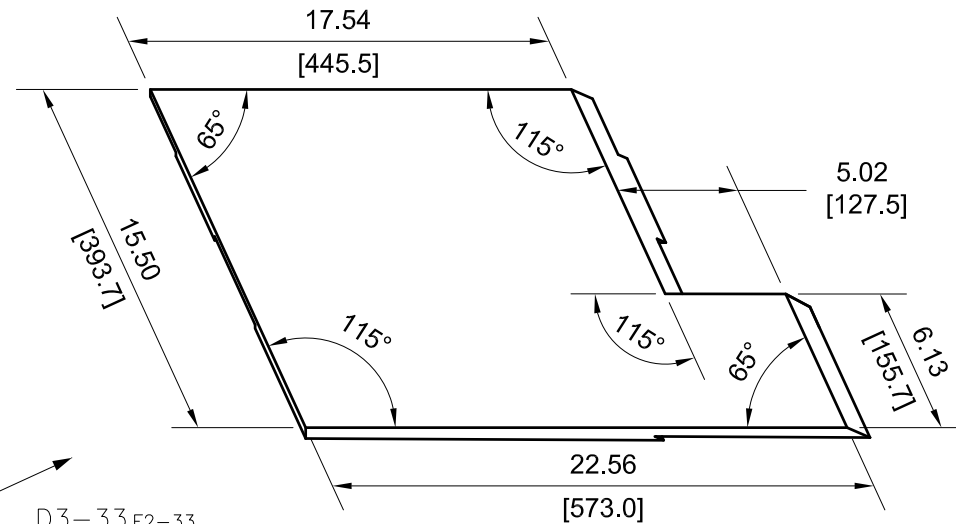

D3-33 F2-33

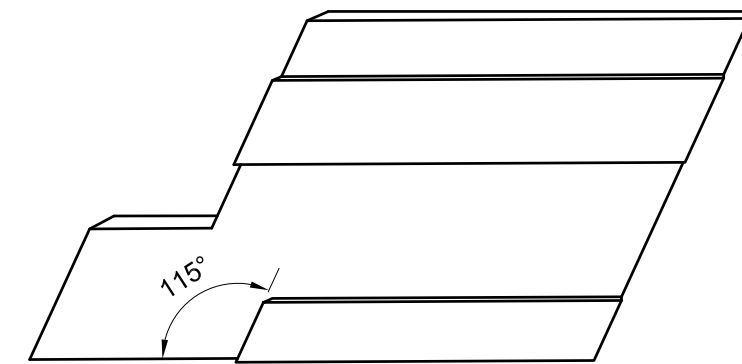
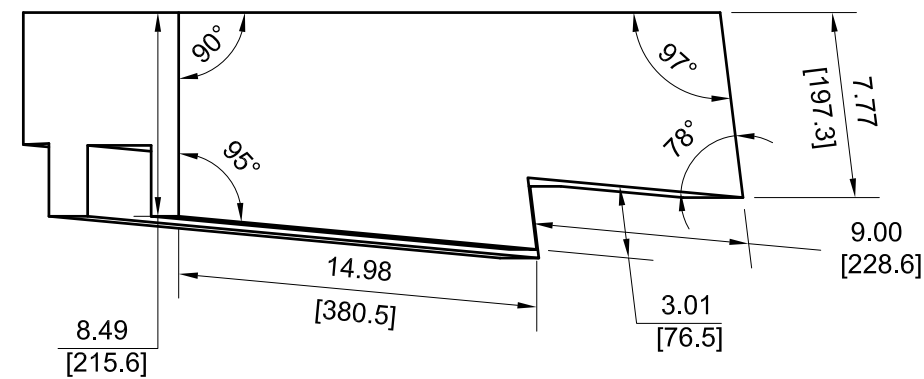

REAR VIEW RELATIVE TO VIEW D4-33

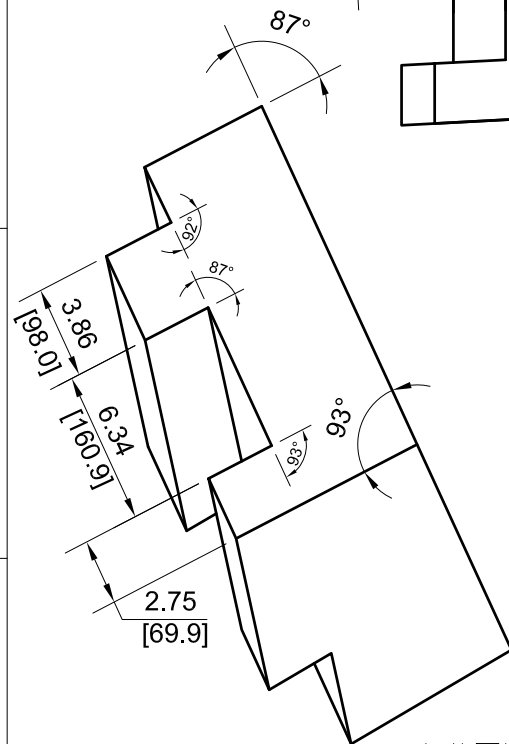

VIEW D3-33

1D6-33 2D6-33

62



DRAWING NUMBER					AES-D0008				
SIZE	SCALE	SHEET	OF	REVISION					
A3	NONE	33	190	B					

64

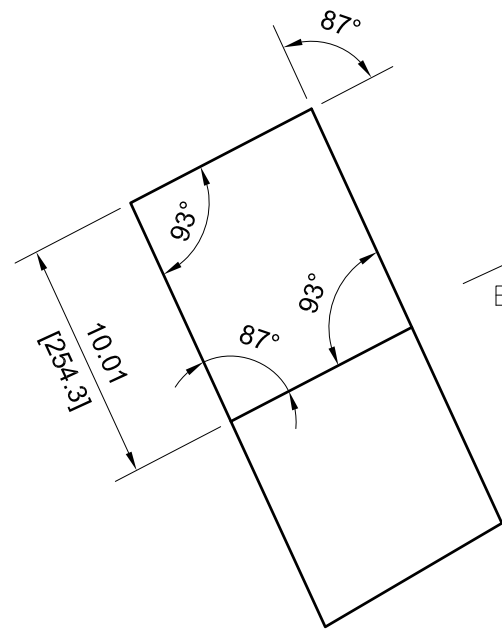
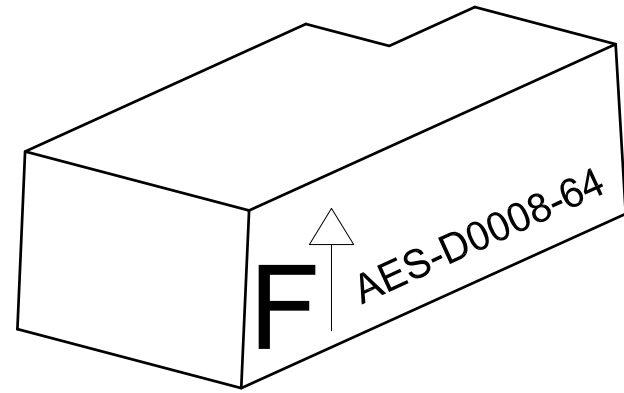
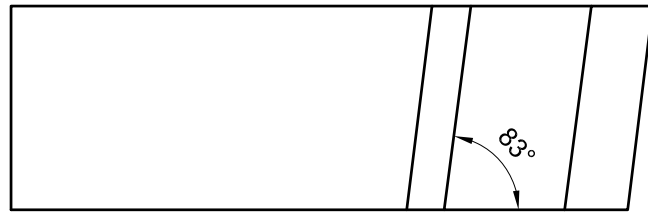

VIEW E2-34

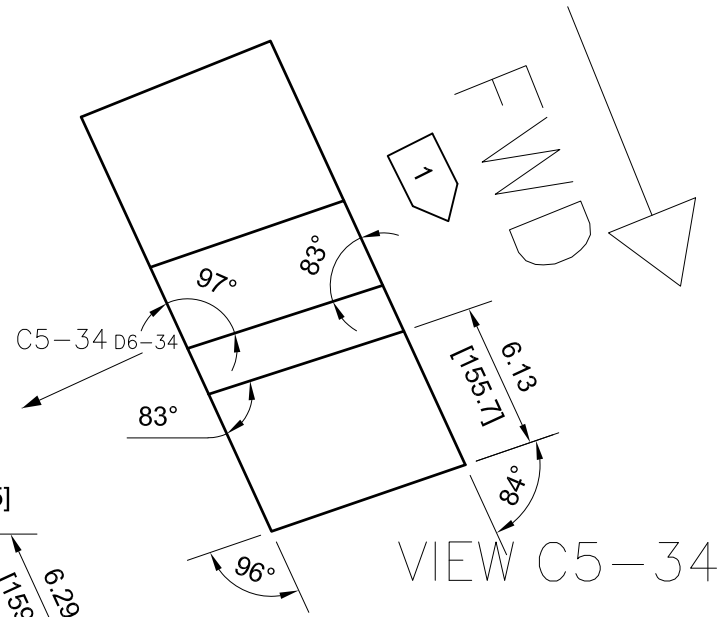
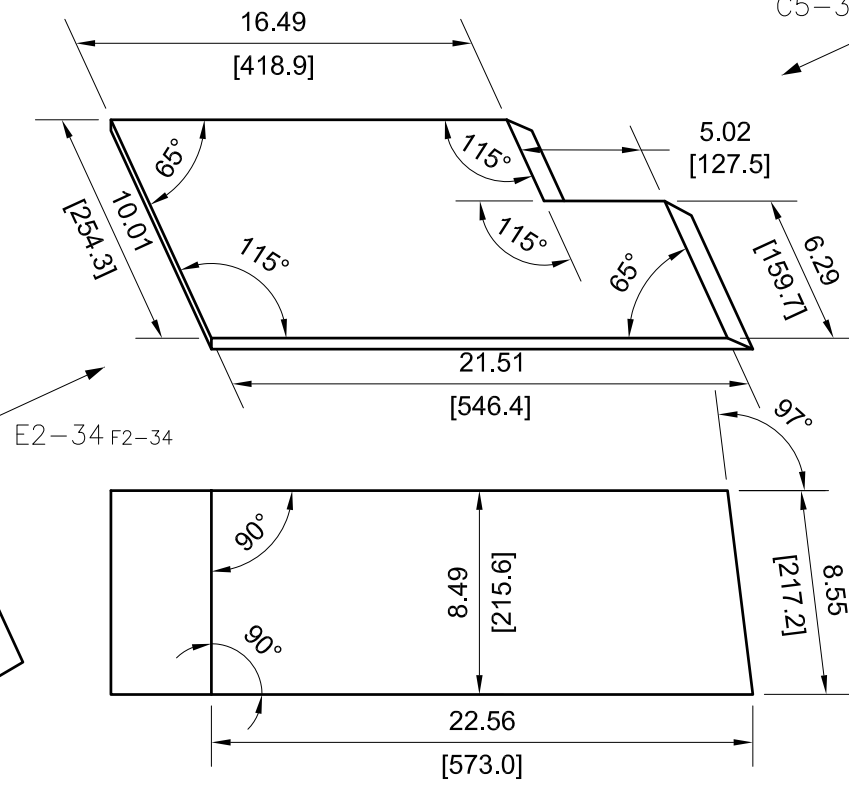

VIEW C5-34

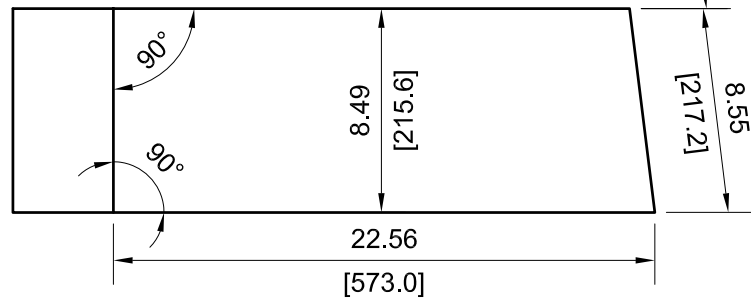

DRAWING NUMBER					AES-D0008				
SIZE	SCALE	SHEET	OF	REVISION					
A3	NONE	34	190	B					

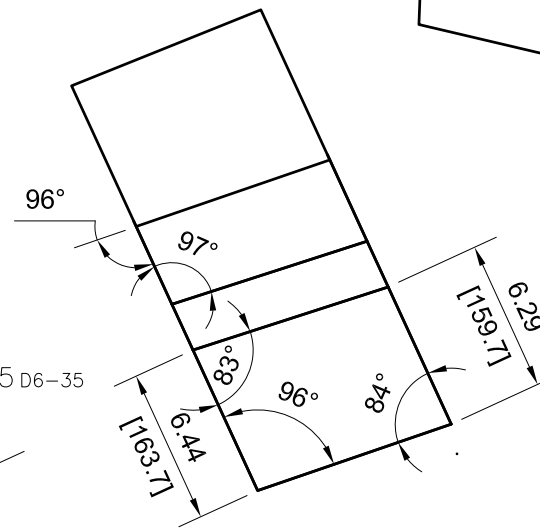
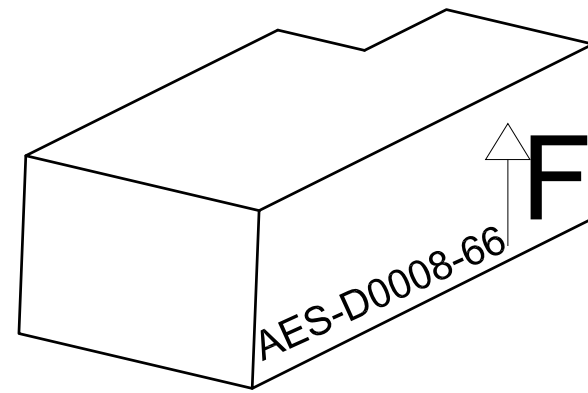
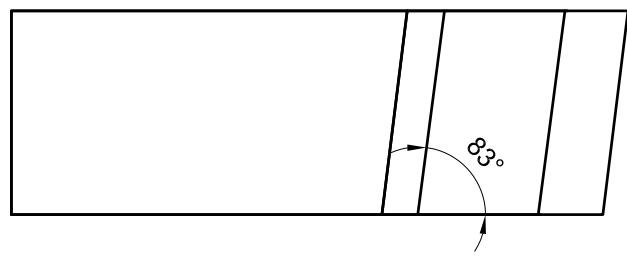
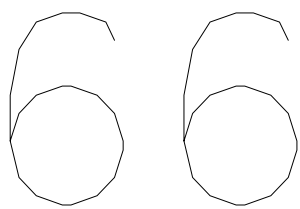

VIEW D5-35

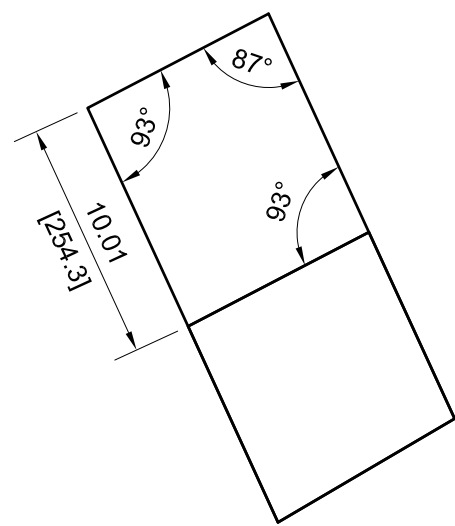
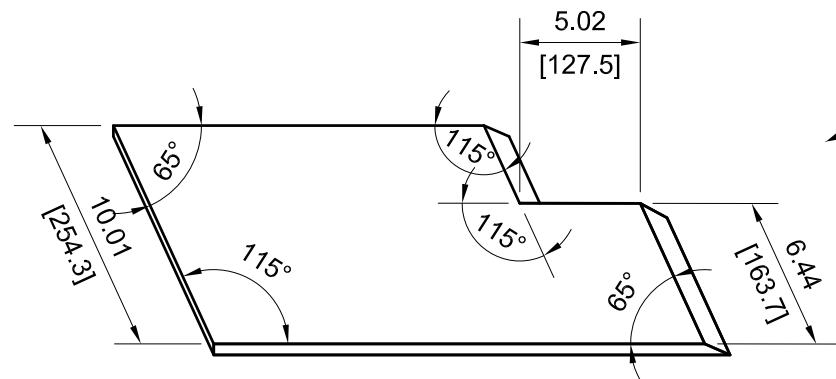

VIEW E2-35

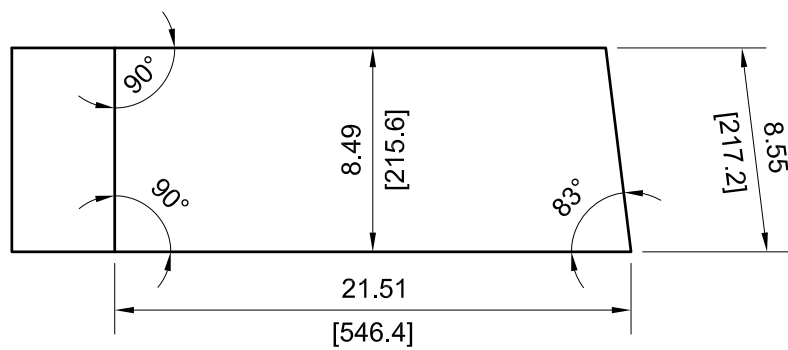

DRAWING NUMBER				
AES-D0008				
SIZE	SCALE	SHEET	OF	REVISION
A3	NONE	35	190	B

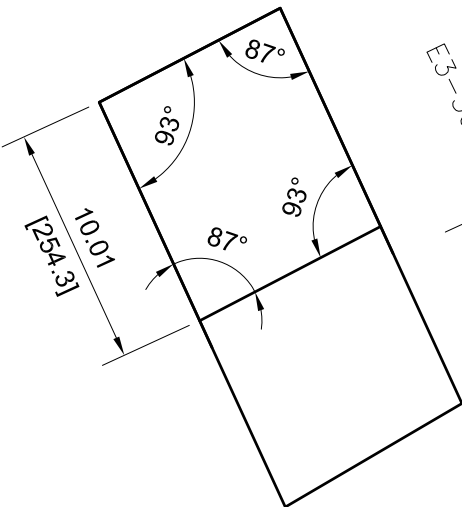
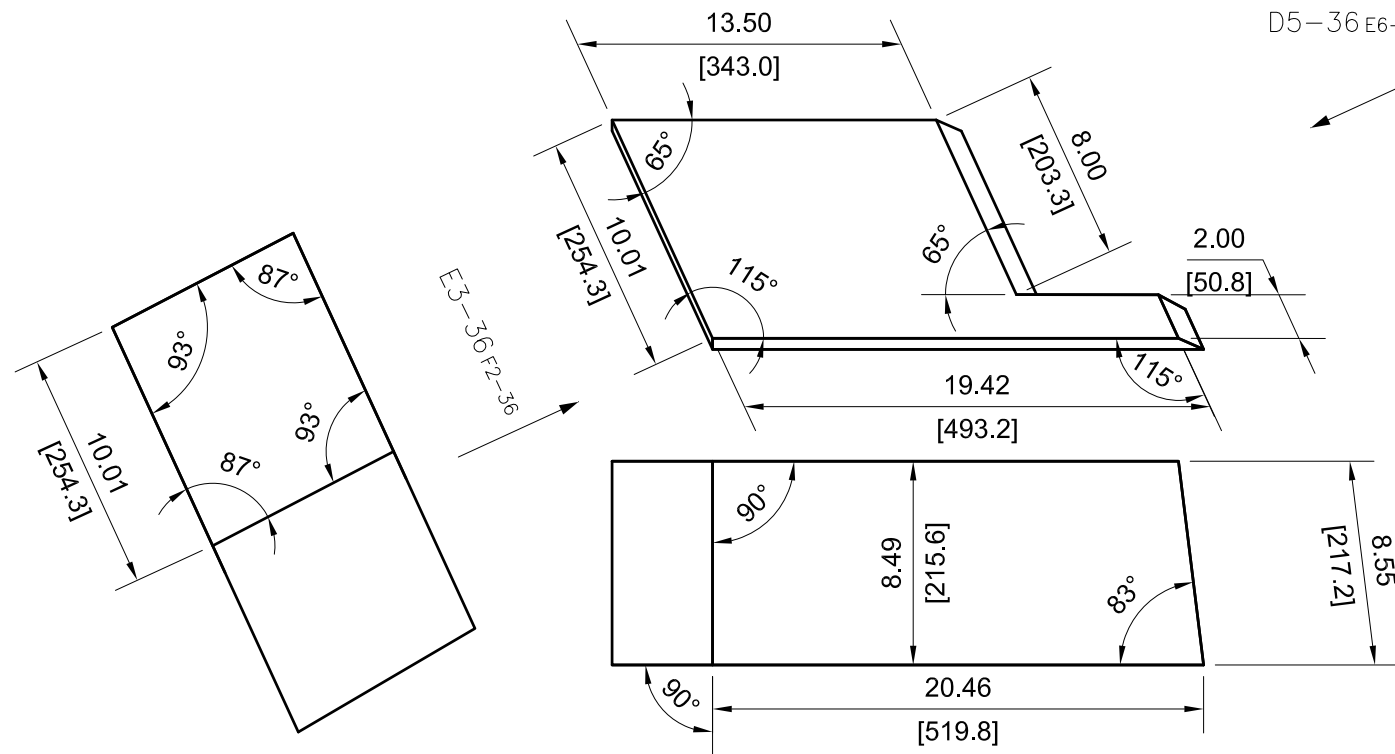
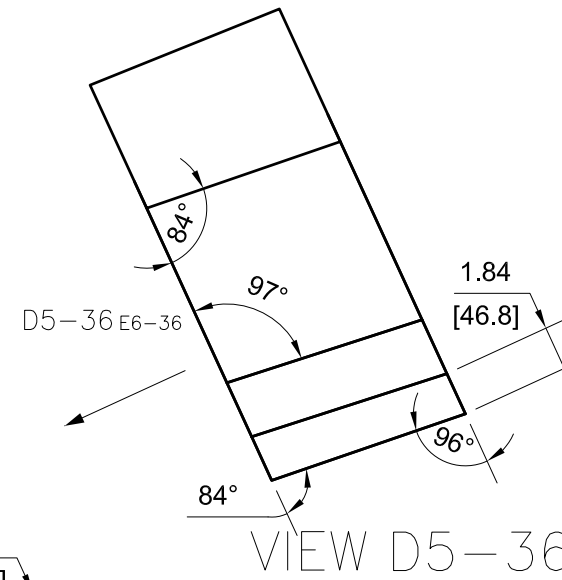
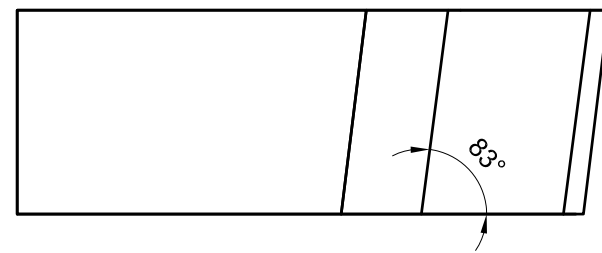
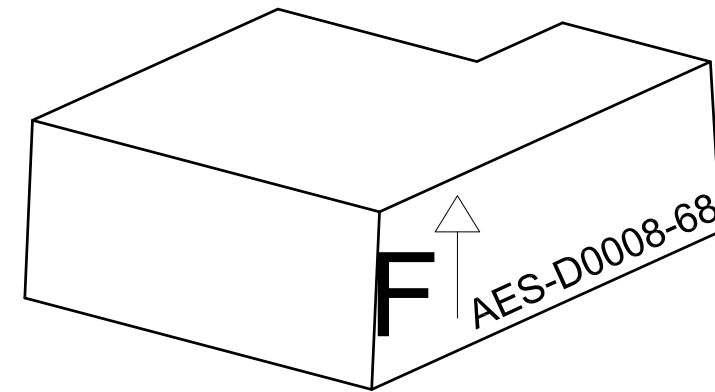
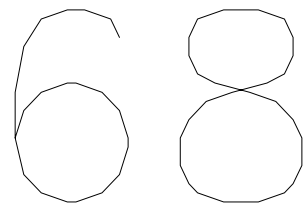

VIEW E3-36

VIEW D5-36



DRAWING NUMBER					AES-D0008		
SIZE	SCALE	SHEET	OF	REVISION			
A3	NONE	36	190	B			

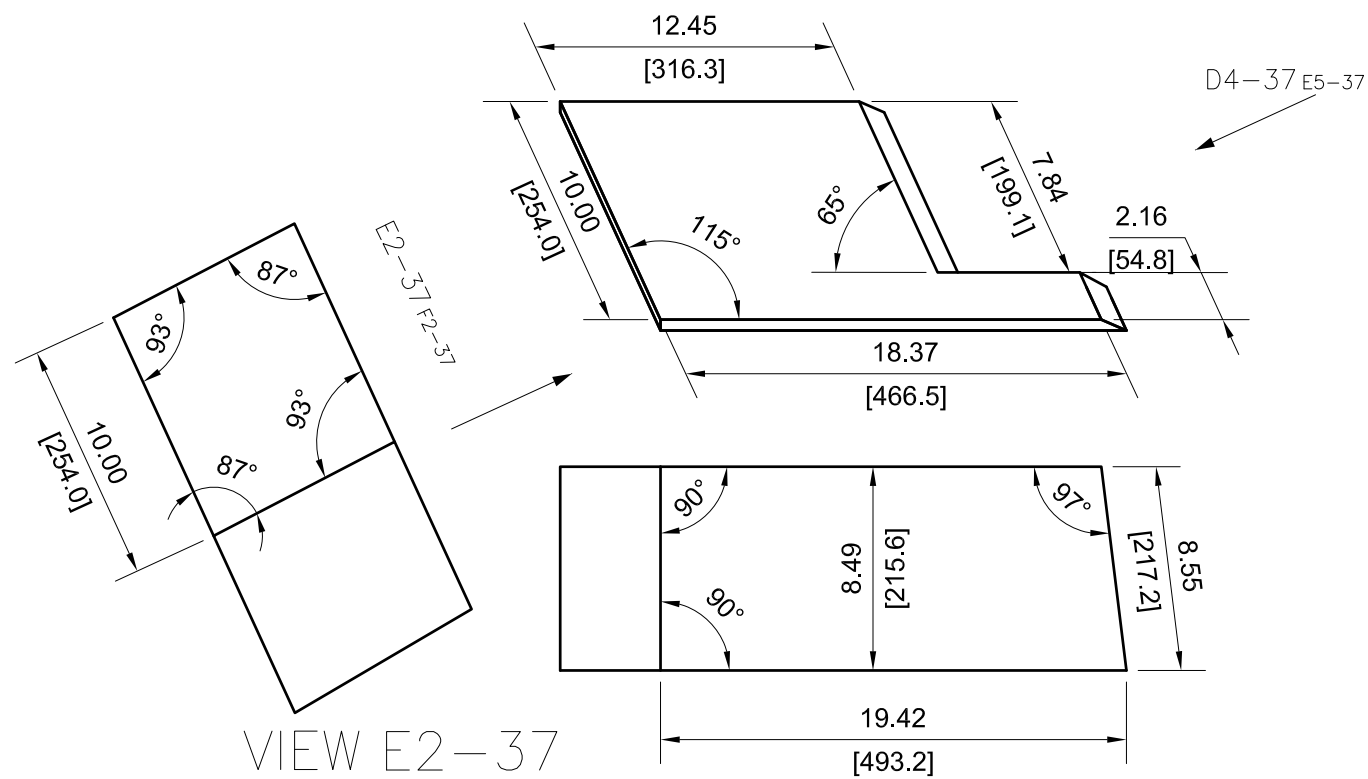
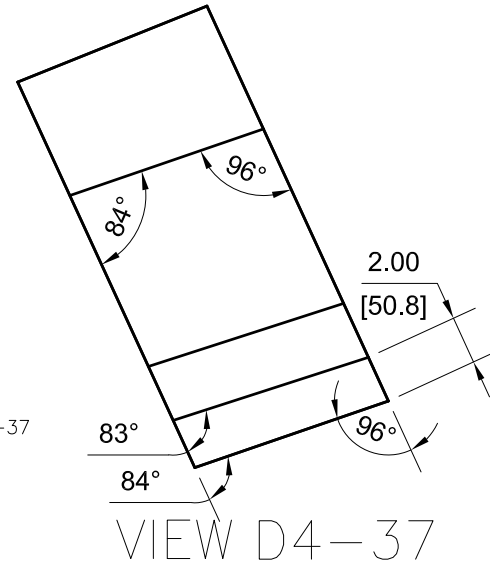
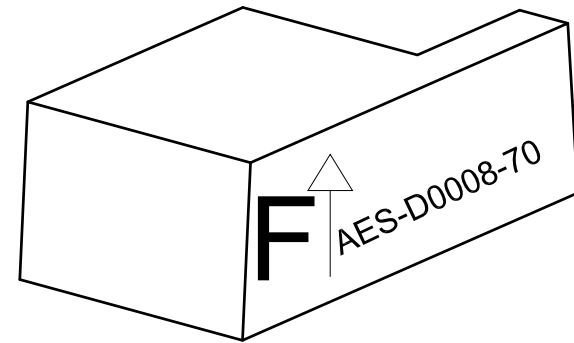
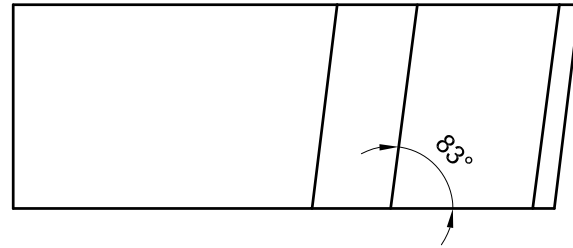
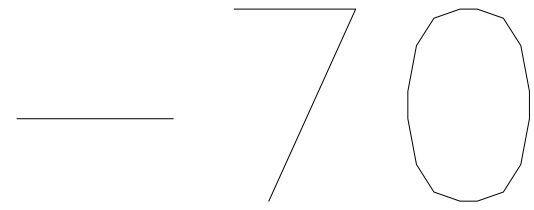

		DRAWING NUMBER			
		AES-D0008			
SIZE	SCALE	SHEET	OF	REVISION	
A3	NONE	37	190	B	

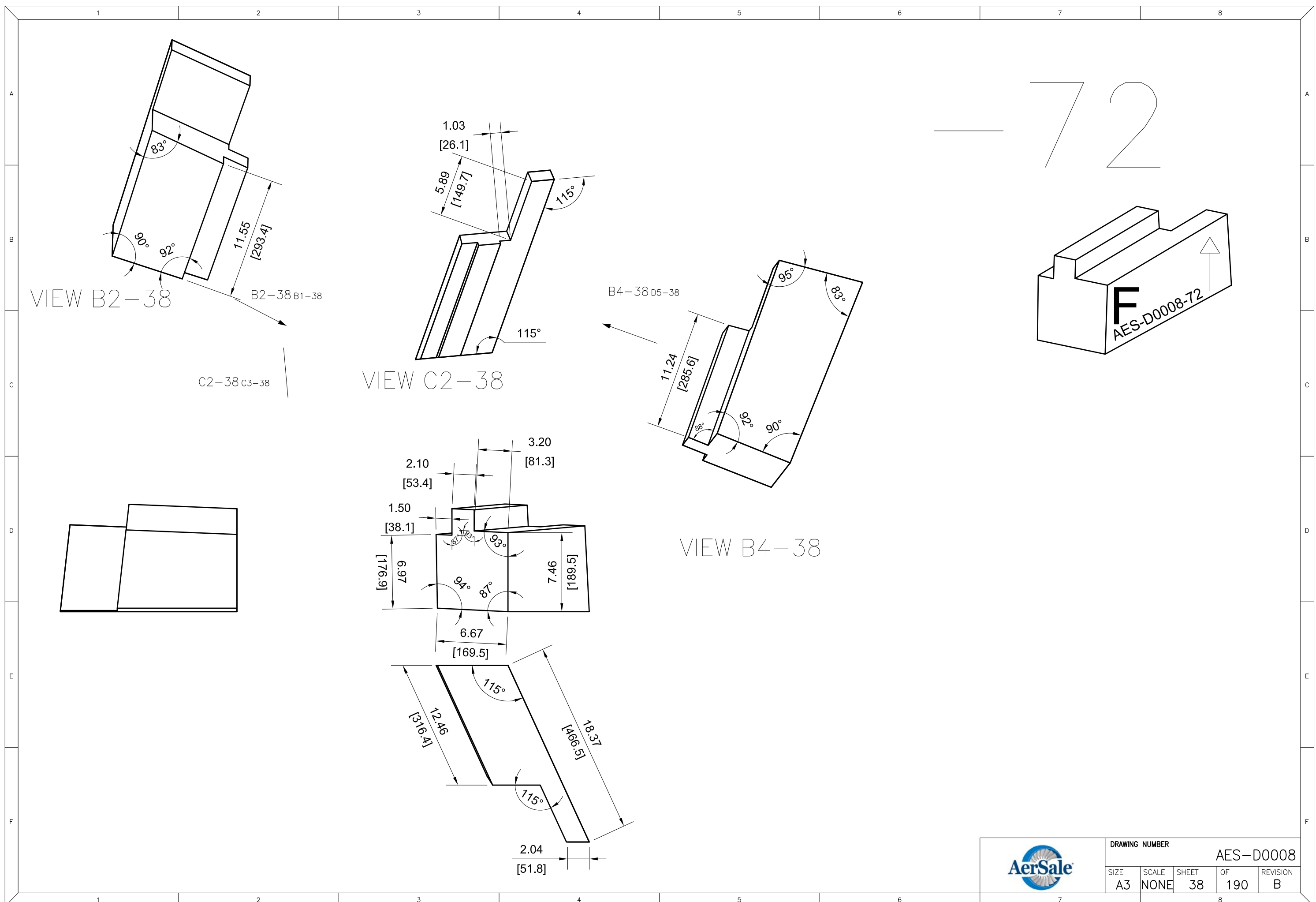

	DRAWING NUMBER				AES-D0008
	SIZE	SCALE	SHEET	OF	REVISION
A3	NONE	38	190	B	

74

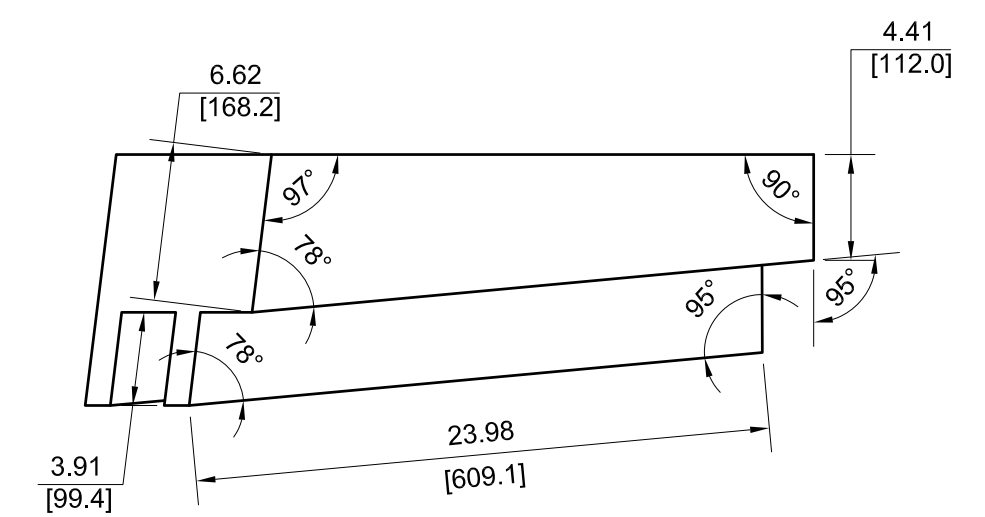
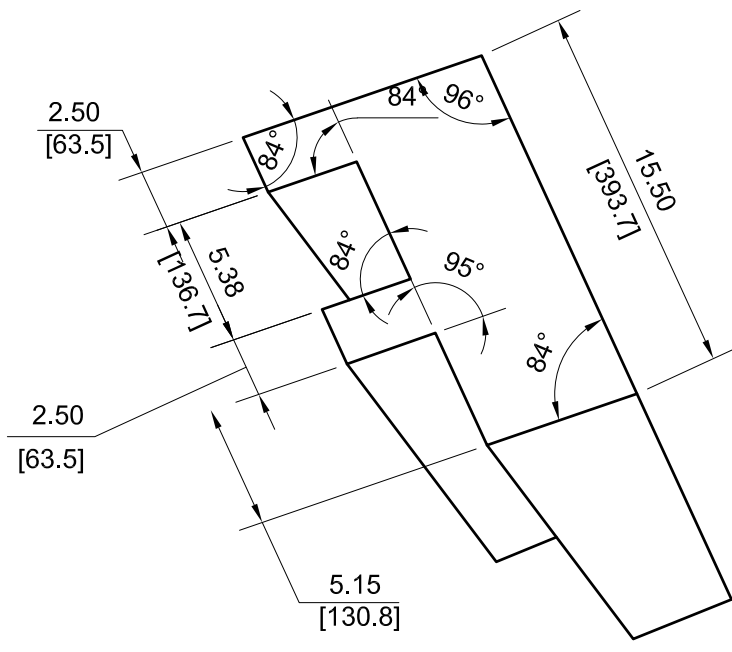
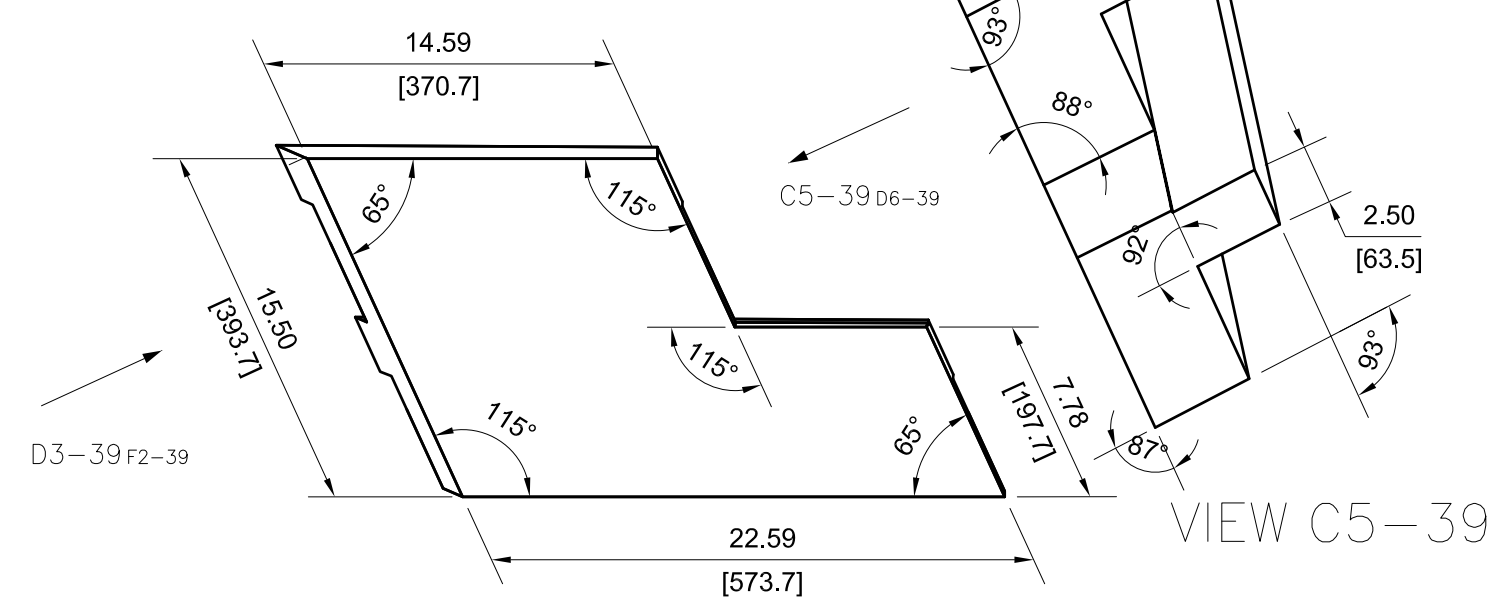
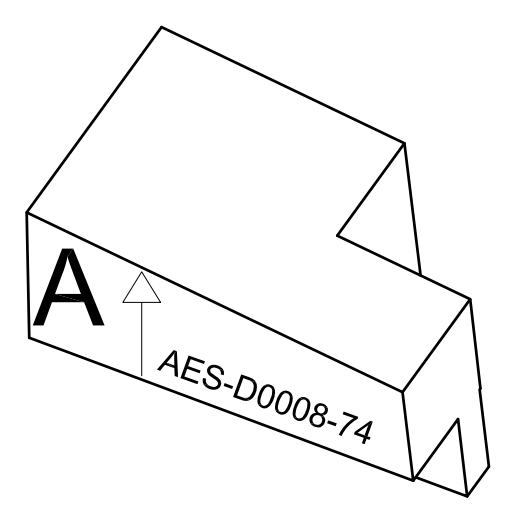
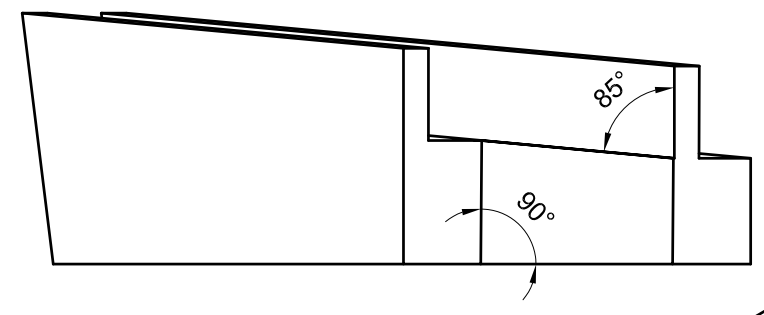

VIEW D3-39

VIEW C5-39



DRAWING NUMBER				
AES-D0008				
SIZE	SCALE	SHEET	OF	REVISION
A3	NONE	39	190	B

76

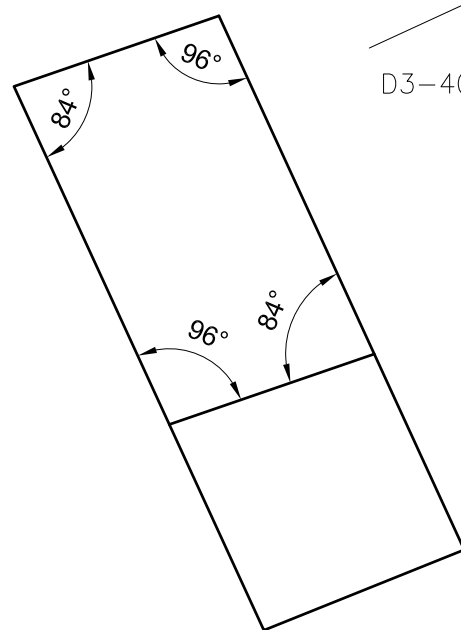
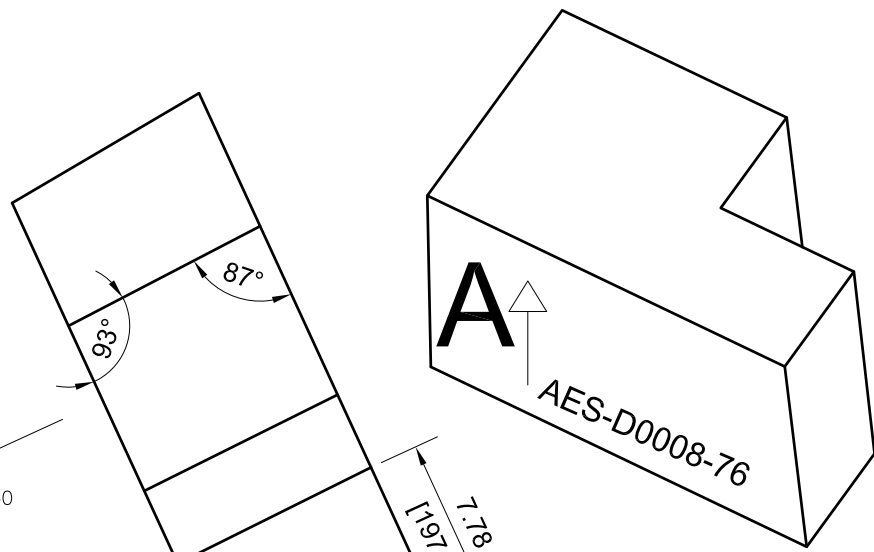
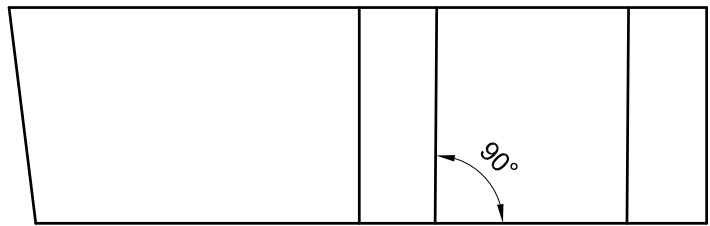

VIEW D3-40

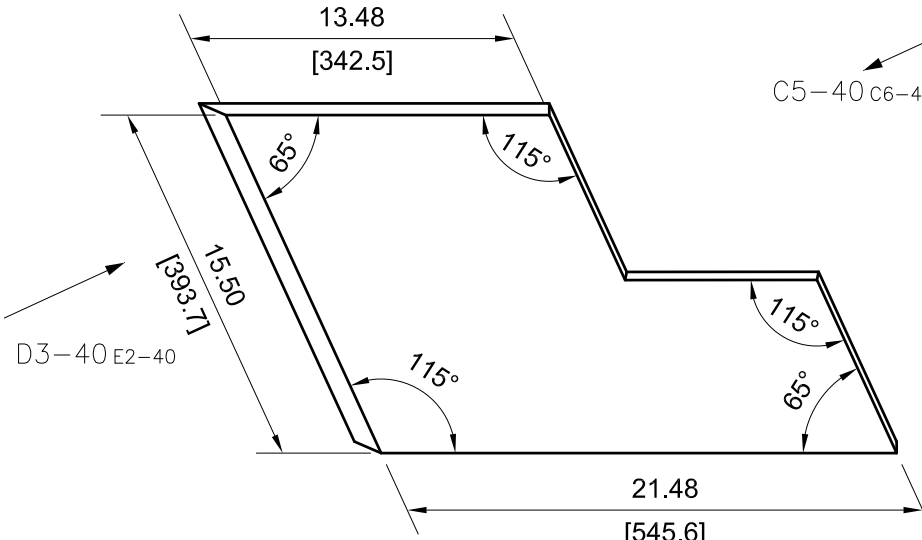

C5-40 C6-40

VIEW C5-40

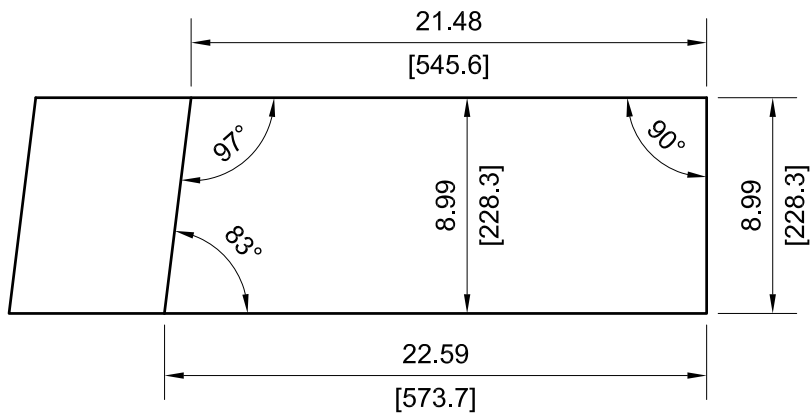

DRAWING NUMBER					AES-D0008				
SIZE	SCALE	SHEET	OF	REVISION					
A3	NONE	40	190	B					

78

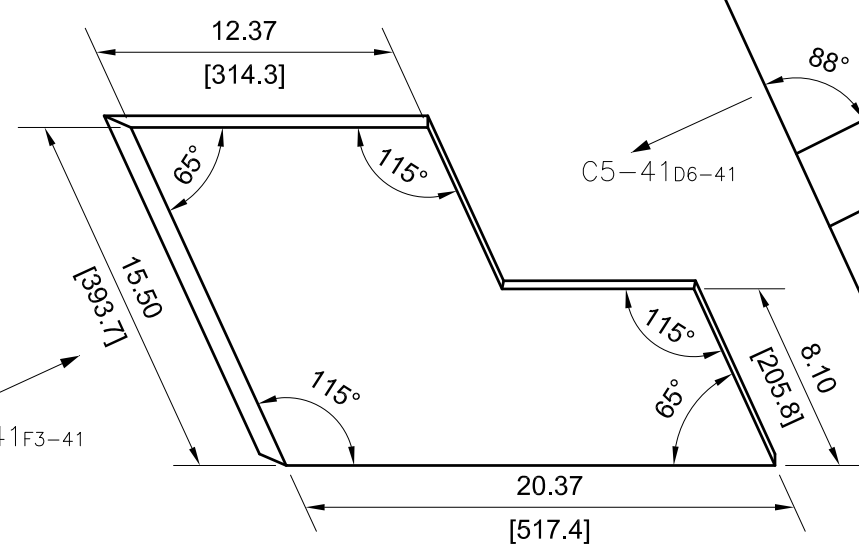
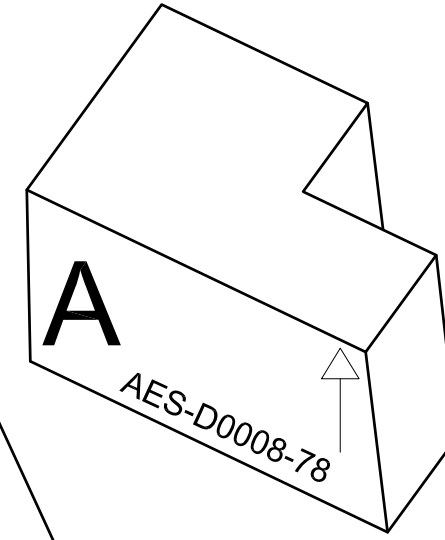
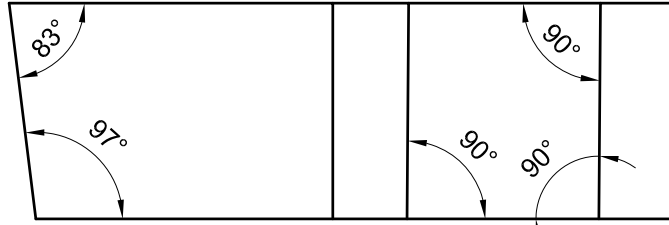

VIEW C5-41

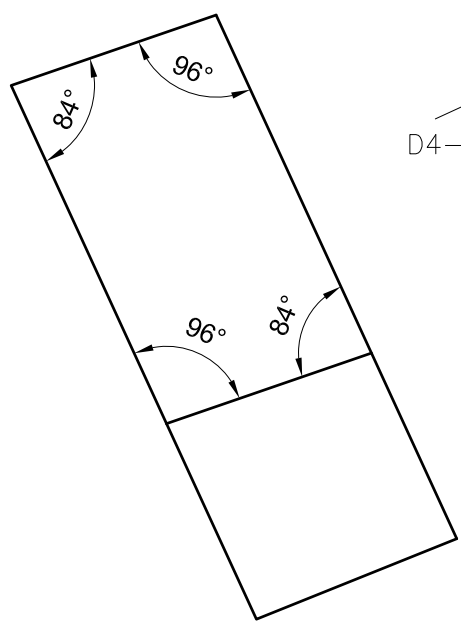

VIEW D4-41

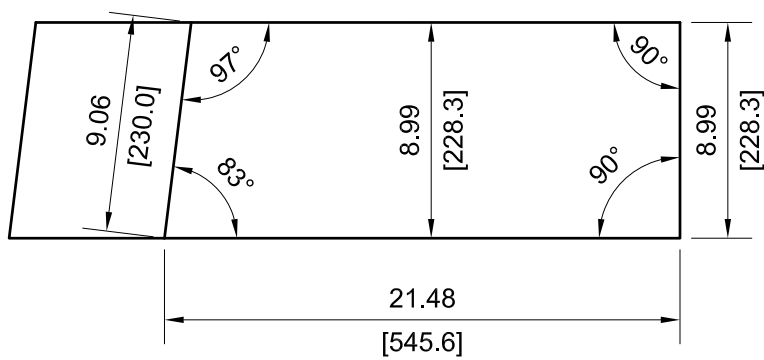

DRAWING NUMBER				
AES-D0008				
SIZE	SCALE	SHEET	OF	REVISION
A3	NONE	41	190	B

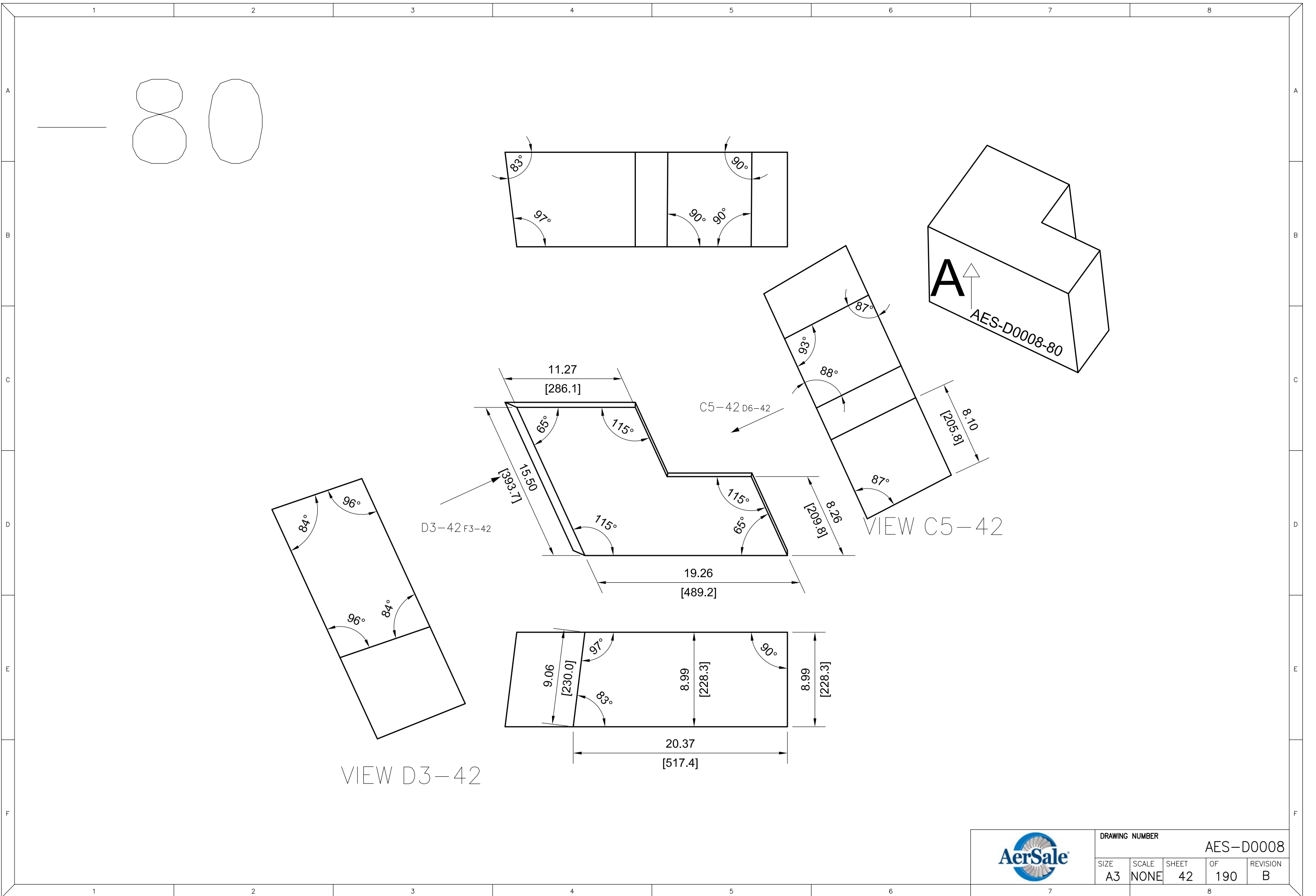

DRAWING NUMBER					AES-D0008				
SIZE	SCALE	SHEET	OF	REVISION					
A3	NONE	42	190	B					

— 82

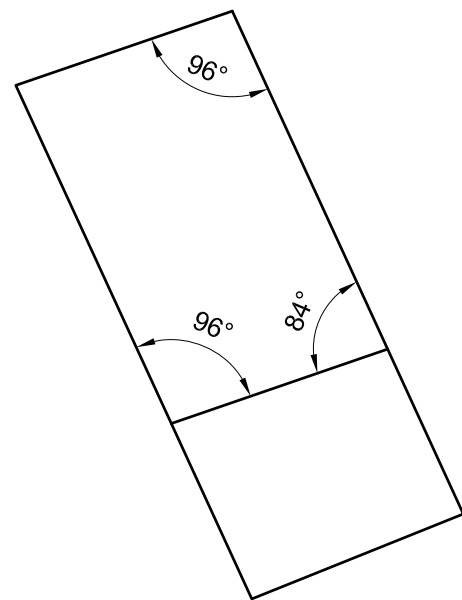
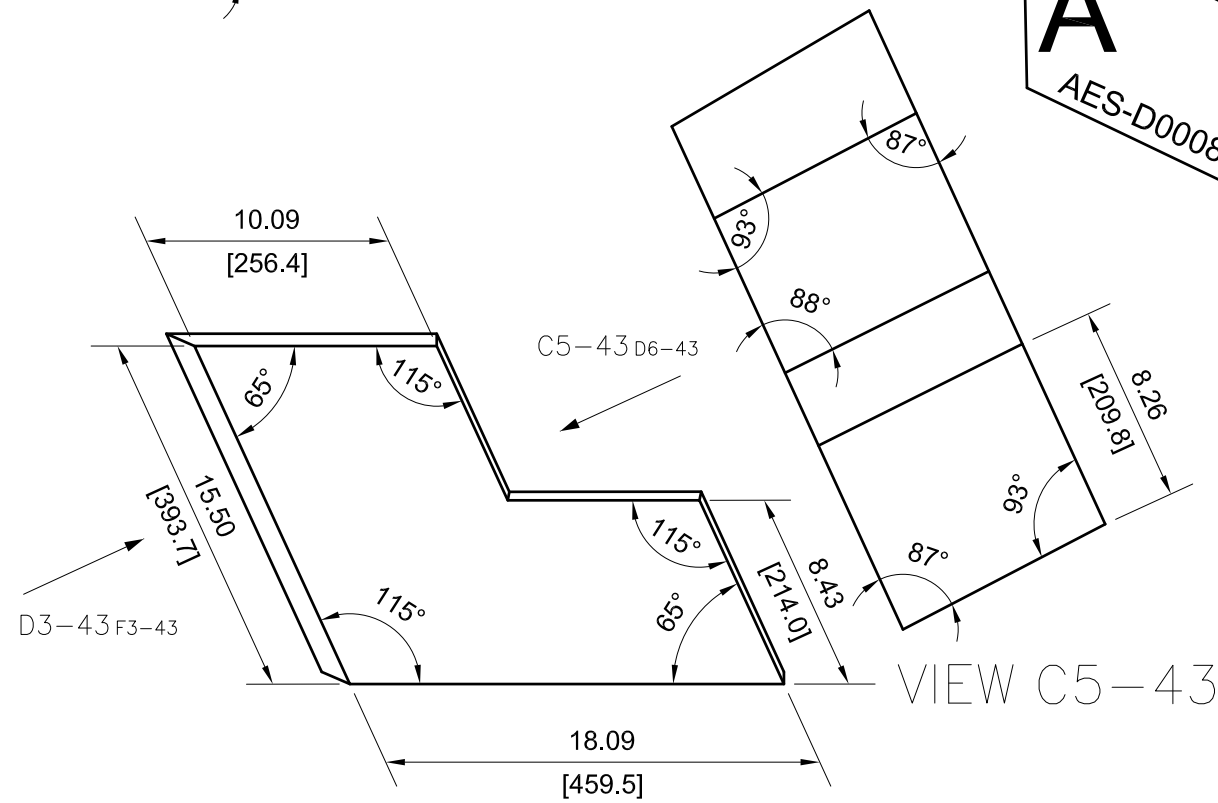
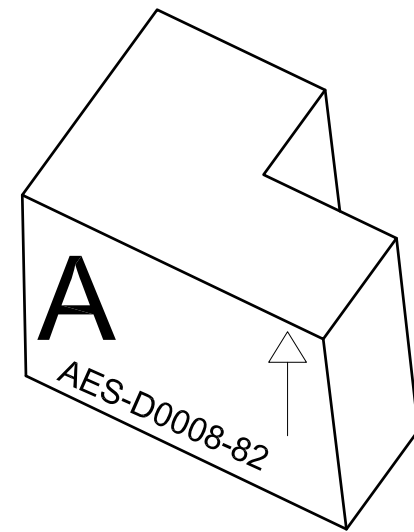
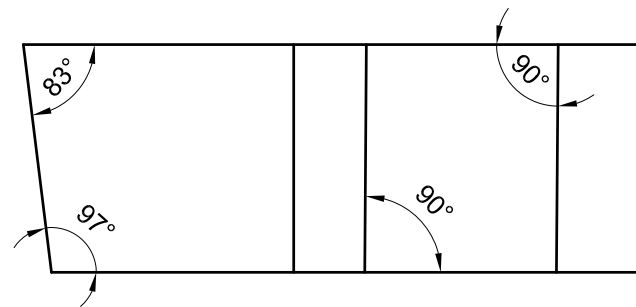

VIEW D3-43

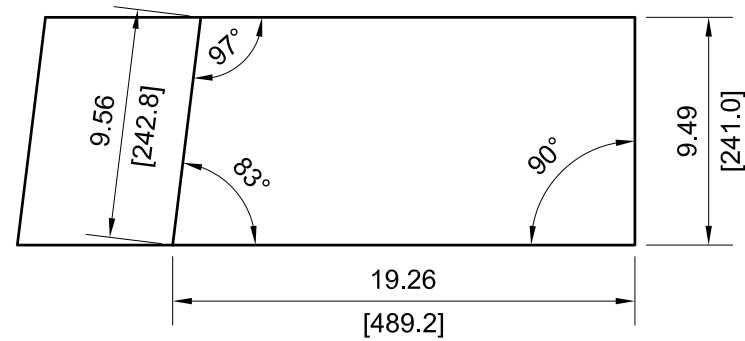

DRAWING NUMBER					AES-D0008	
SIZE	SCALE	SHEET	OF	REVISION		
A3	NONE	43	190	B		

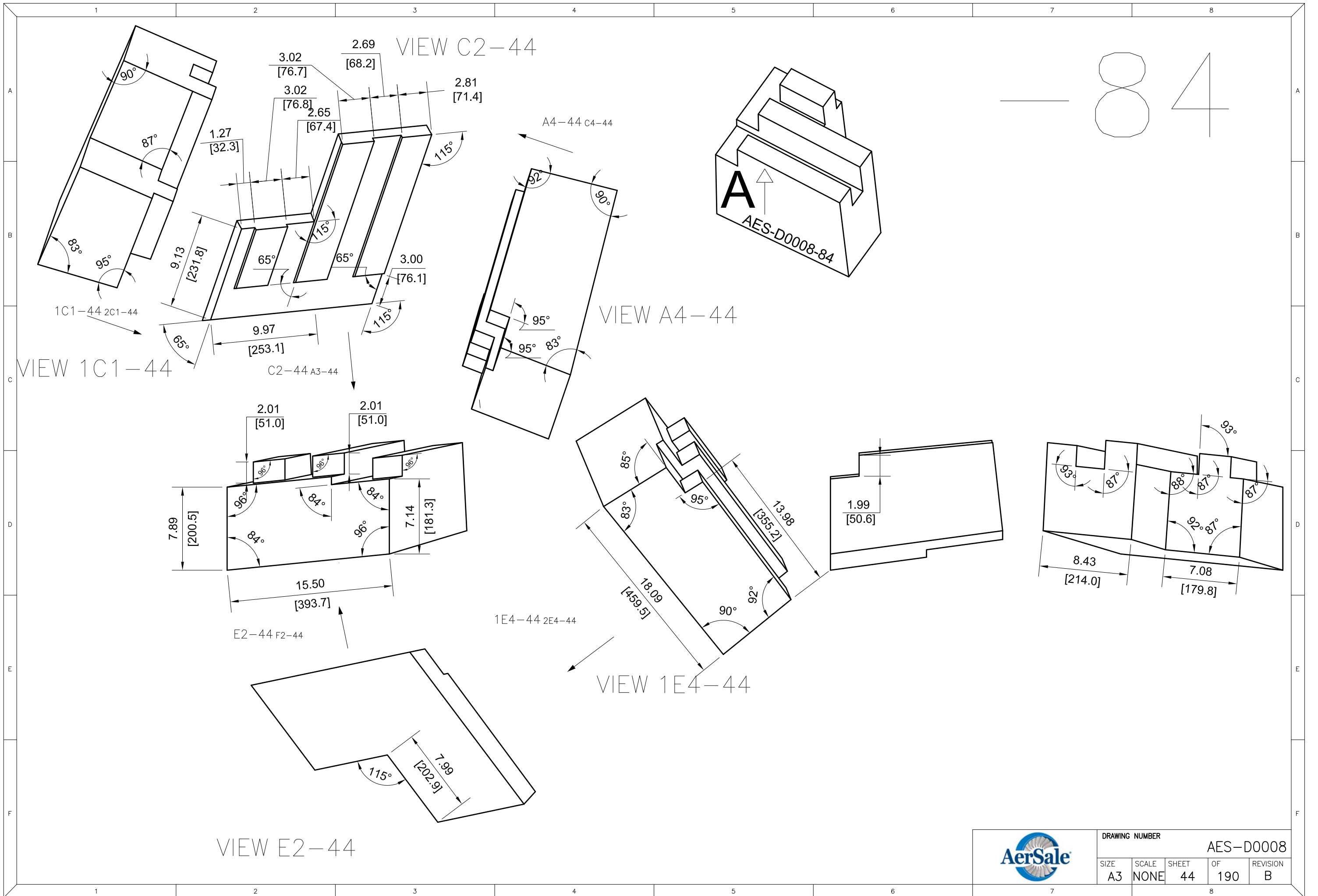

	DRAWING NUMBER				
	AES-D0008				
SIZE	SCALE	SHEET	OF	REVISION	
A3	NONE	44	190	B	

86

SECTION VIEW C5-45

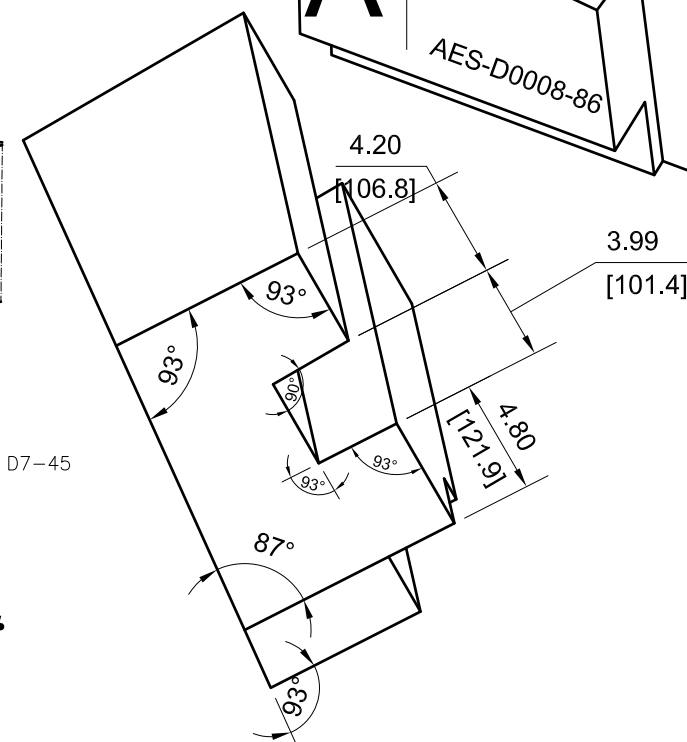
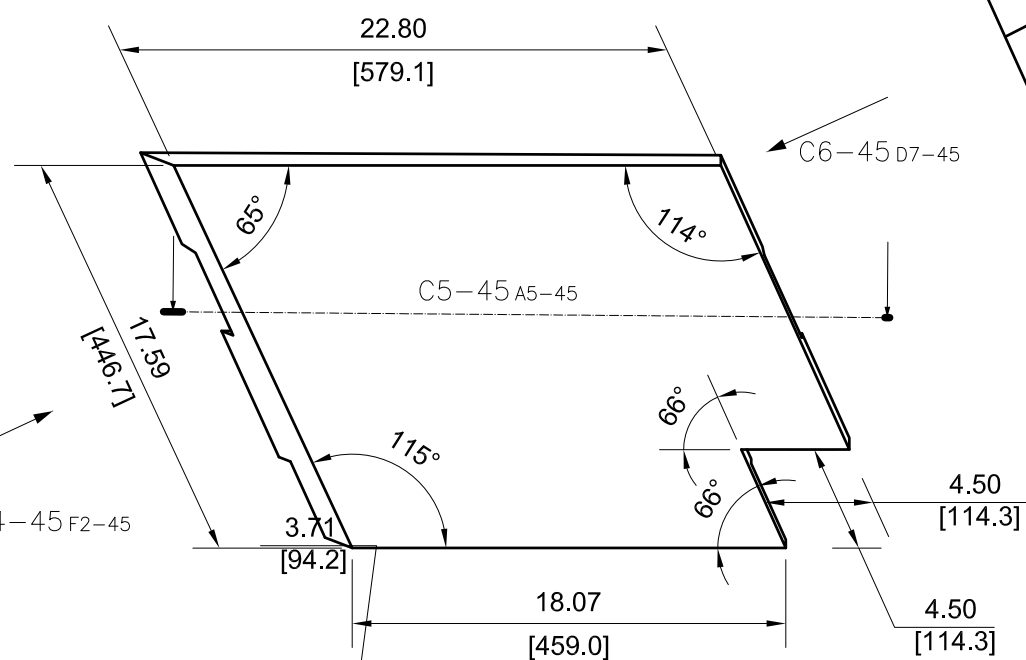
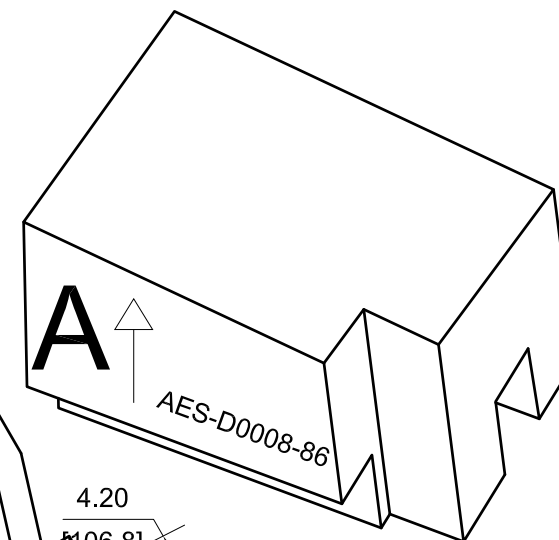
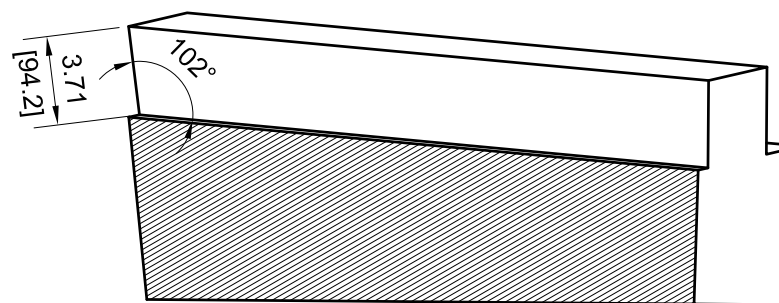

VIEW C6-45

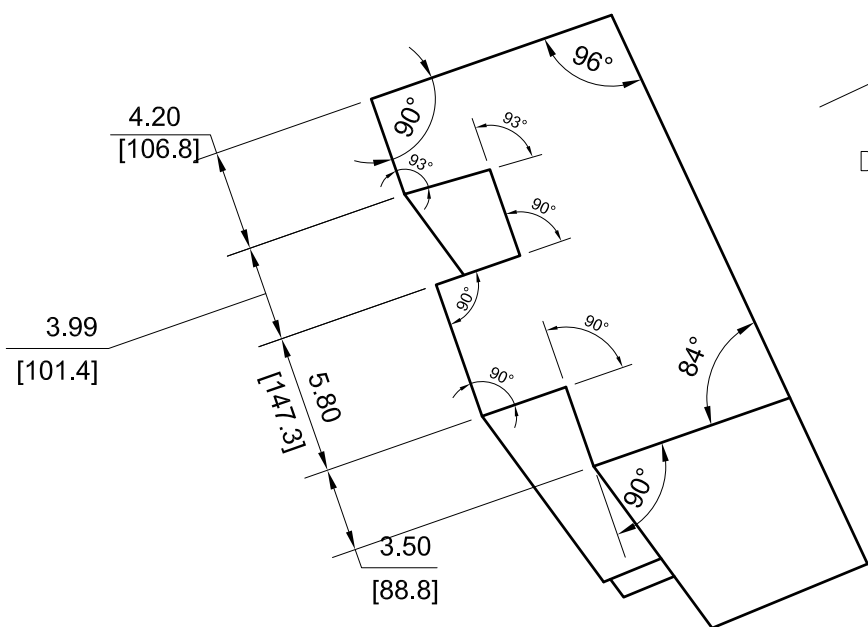

VIEW D4-45

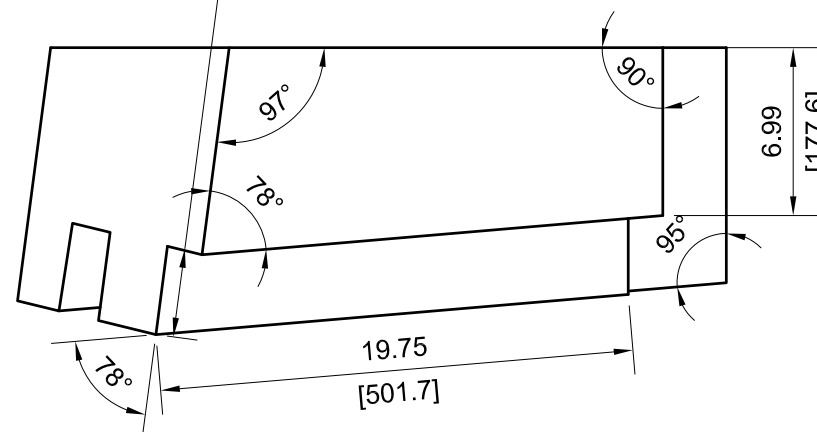

DRAWING NUMBER					AES-D0008	
SIZE	SCALE	SHEET	OF	REVISION		
A3	NONE	45	190	B		

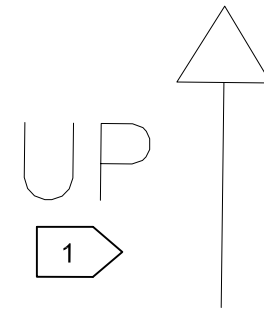
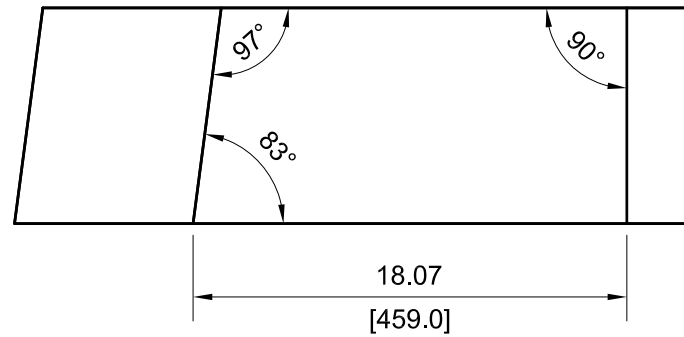
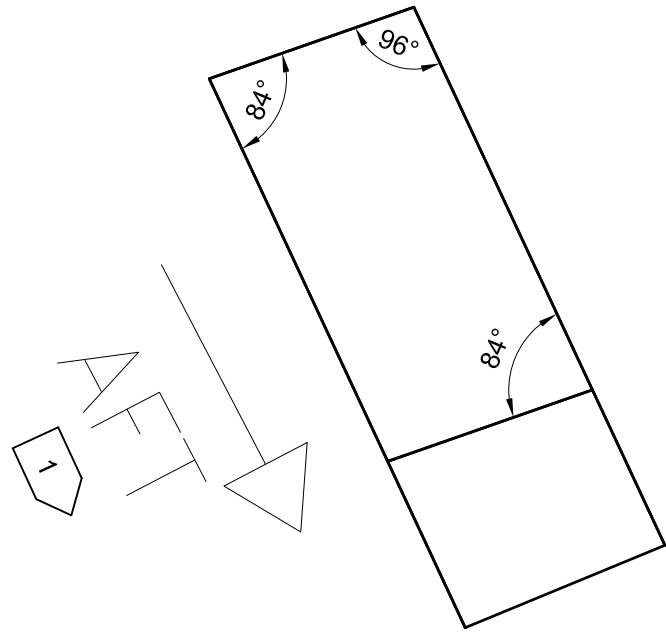
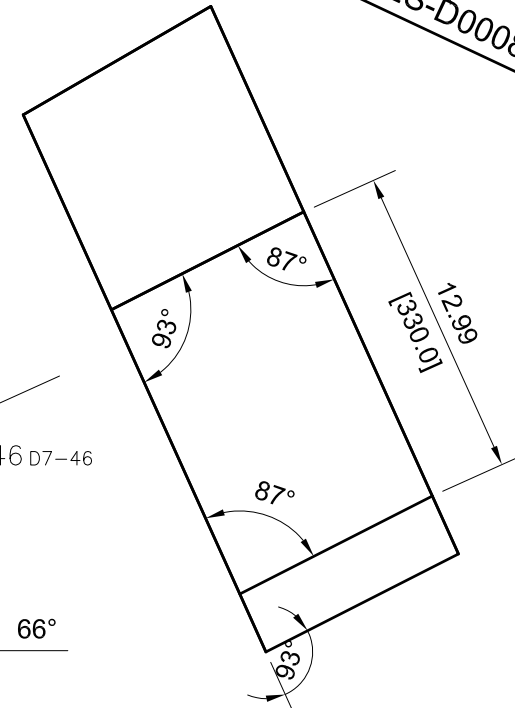
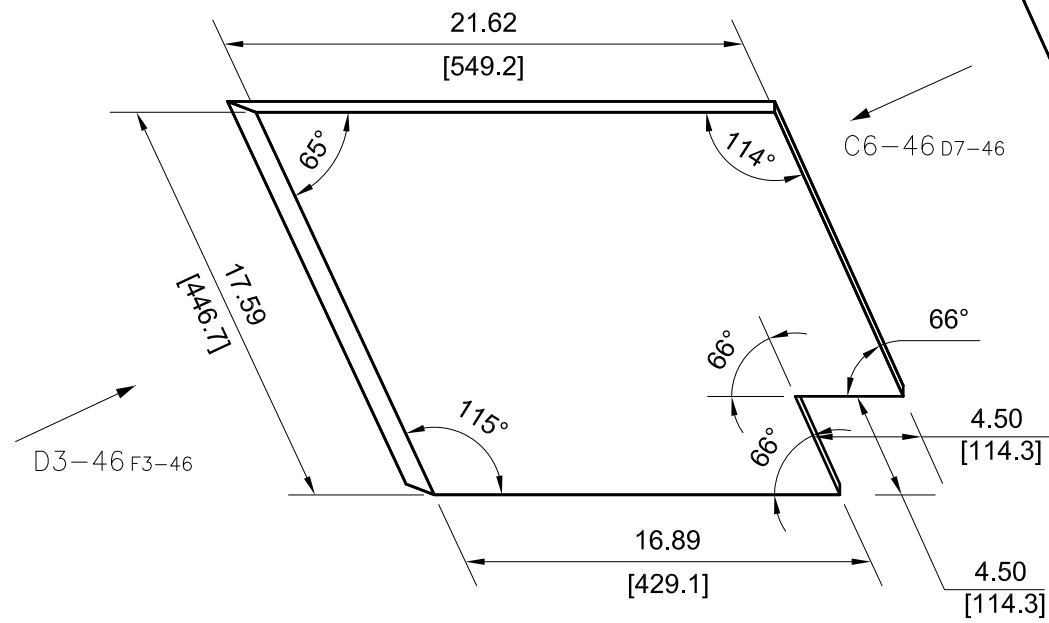
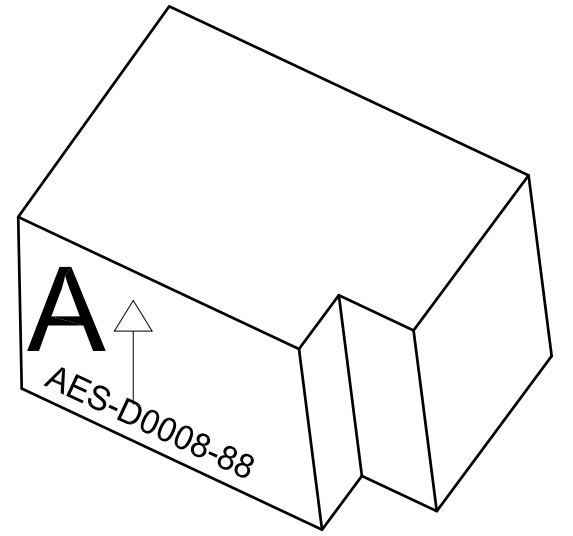
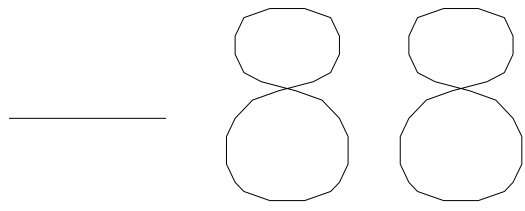

		DRAWING NUMBER			
		AES-D0008			
SIZE	SCALE	SHEET	OF	REVISION	
A3	NONE	46	190	B	

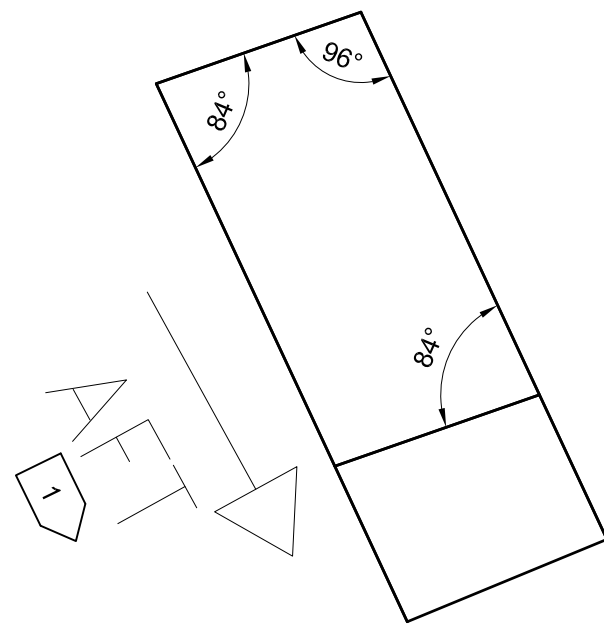
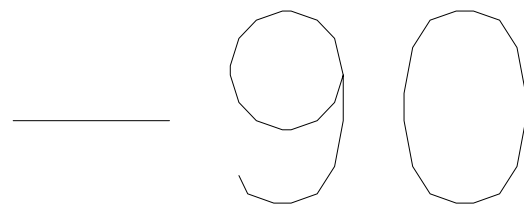

VIEW D4-47

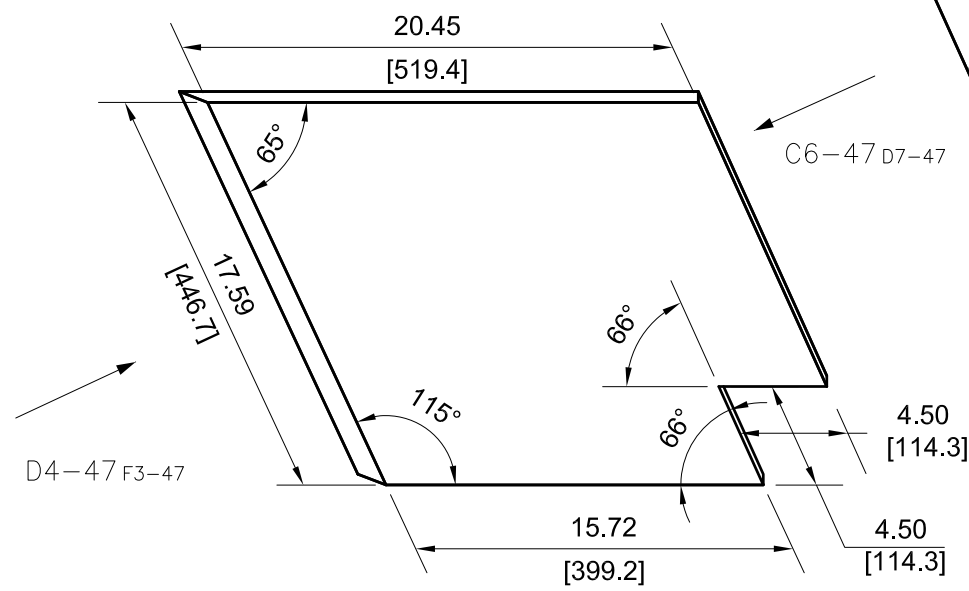

VIEW C6-47

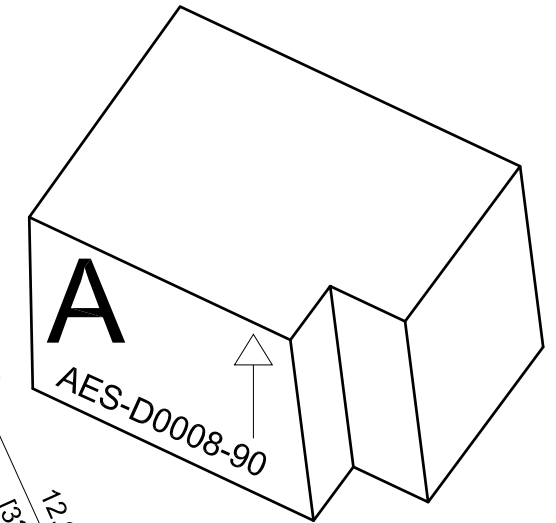
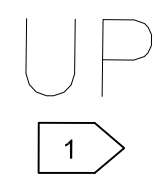
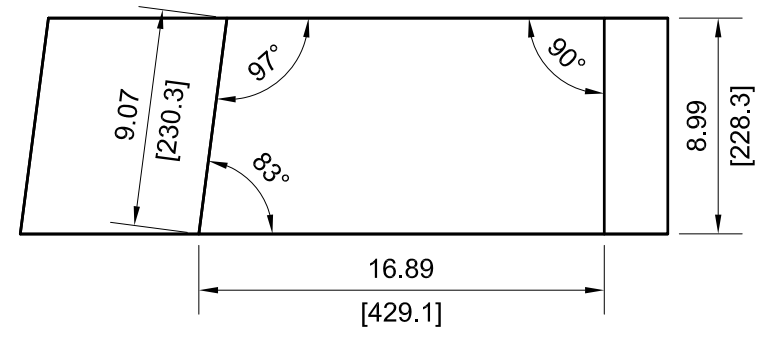

		DRAWING NUMBER			
		AES-D0008			
SIZE	SCALE	SHEET	OF	REVISION	
A3	NONE	47	190	B	

— 92

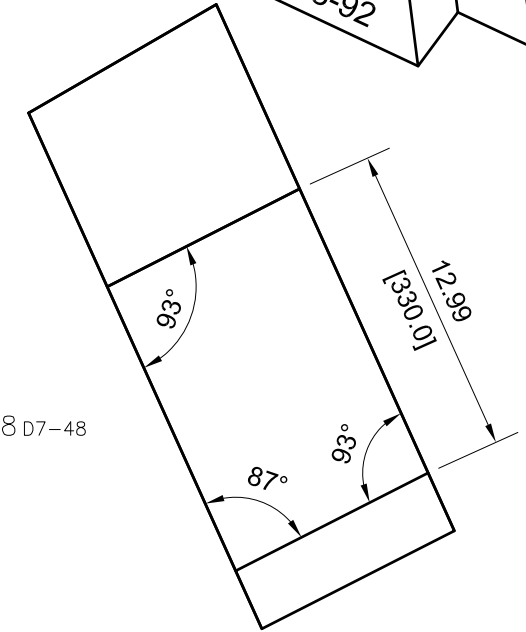
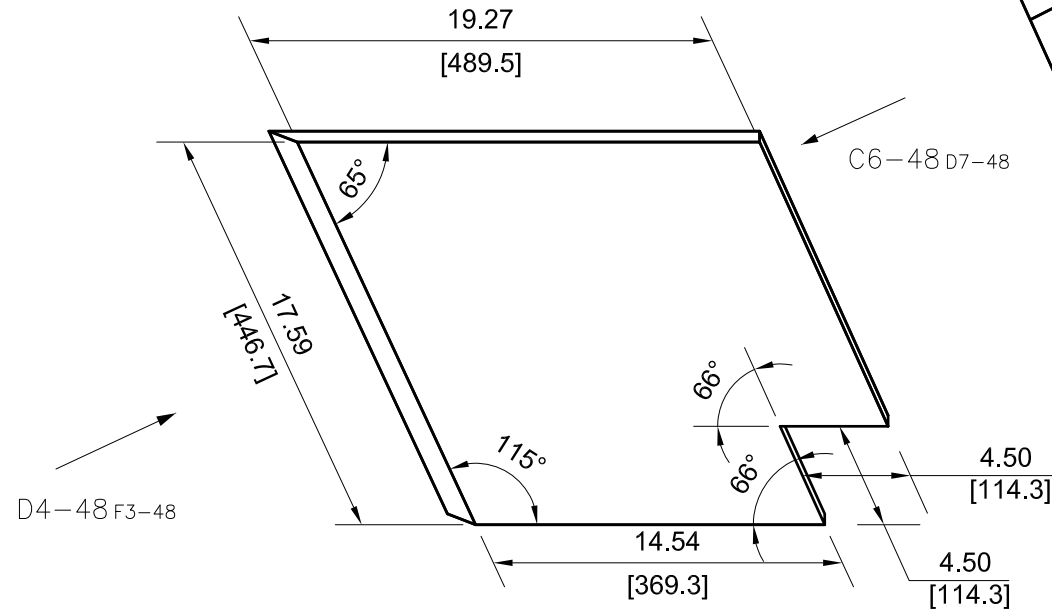
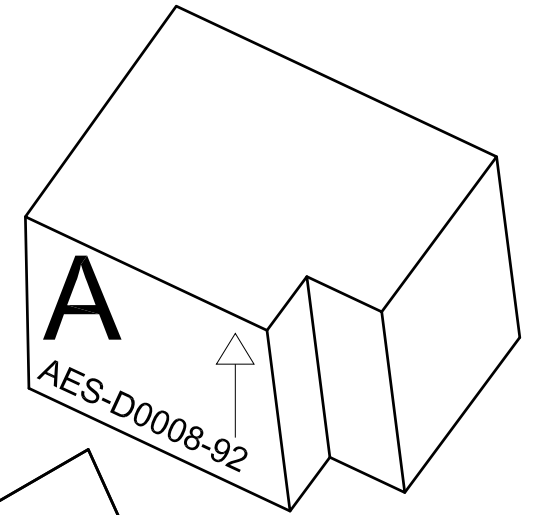

VIEW C6-48

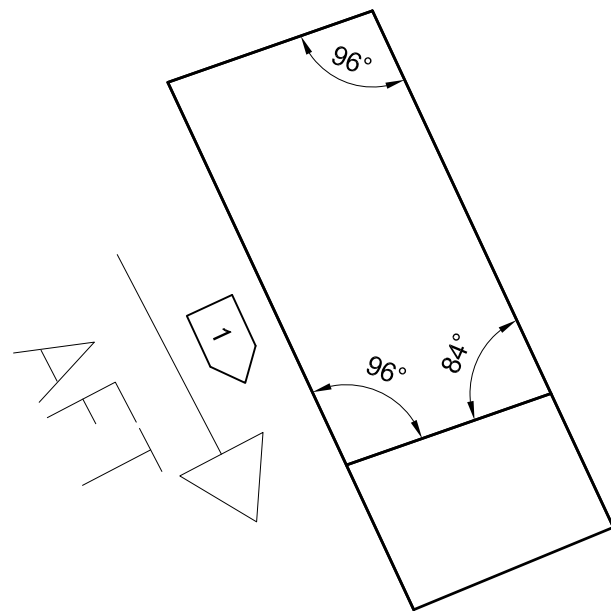

VIEW D4-48

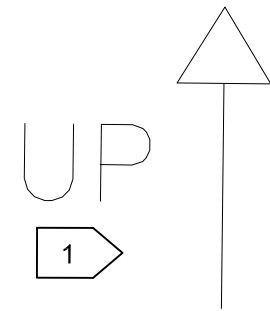

		DRAWING NUMBER			
		AES-D0008			
SIZE	SCALE	SHEET	OF	REVISION	
A3	NONE	48	190	B	

94

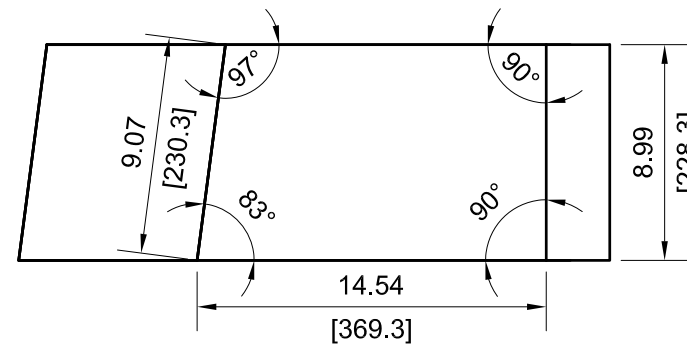
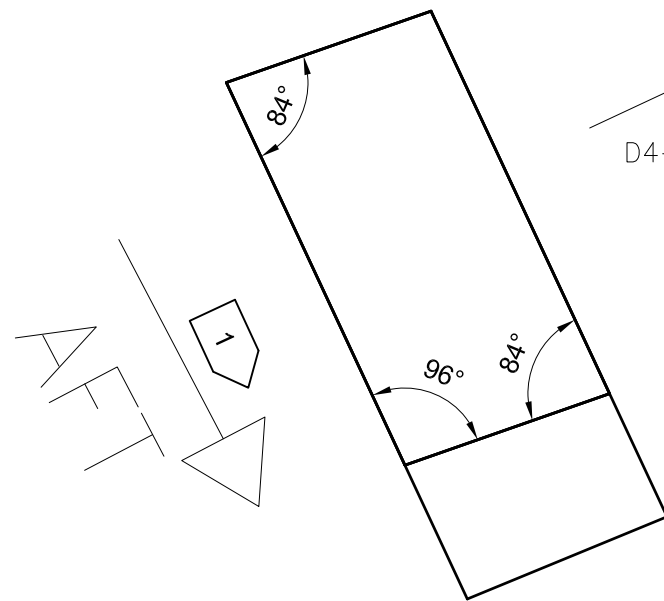
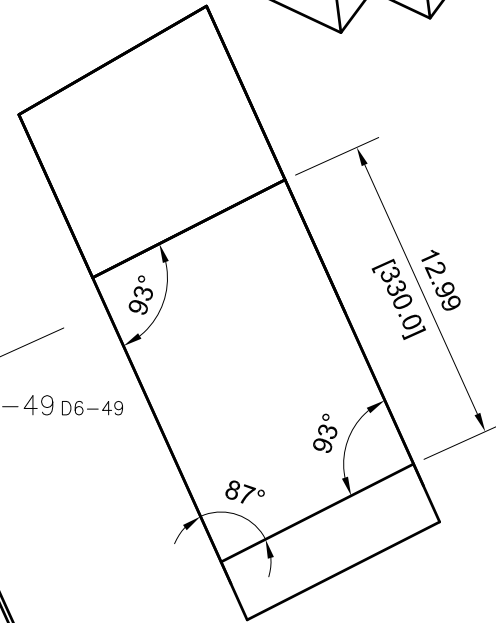
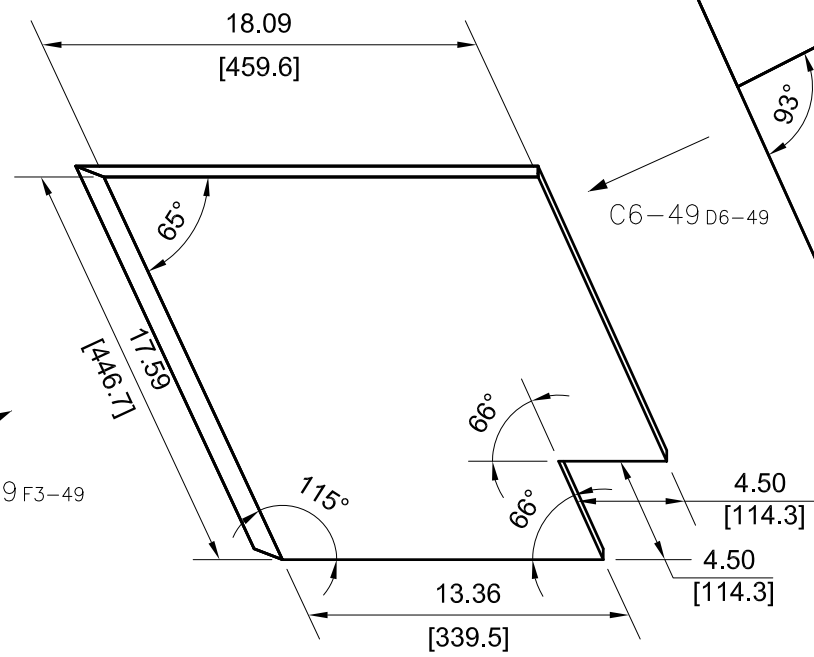
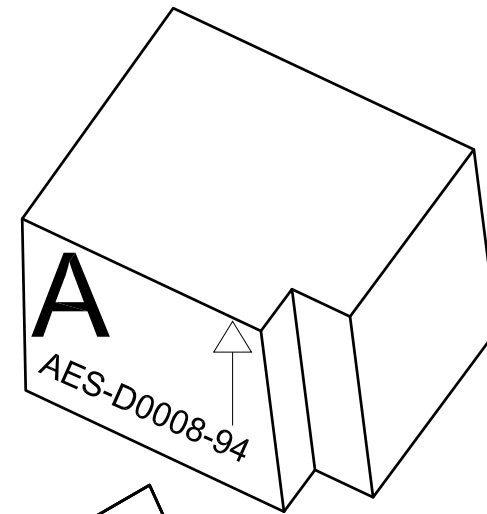

VIEW C6-49

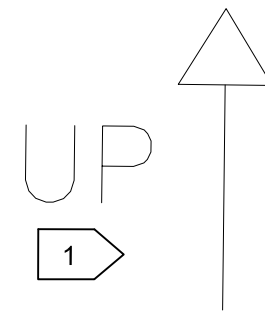

VIEW D4-49



DRAWING NUMBER				
AES-D0008				
SIZE	SCALE	SHEET	OF	REVISION
A3	NONE	49	190	B

96

VIEW D5-50

VIEW C5-50

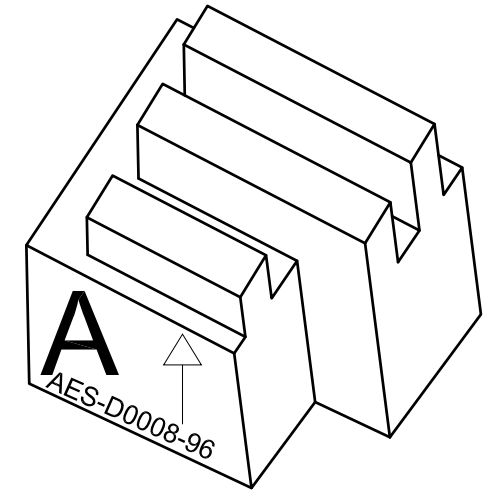

VIEW C3-50

C3-50 c2-50

D5-50 c4-50

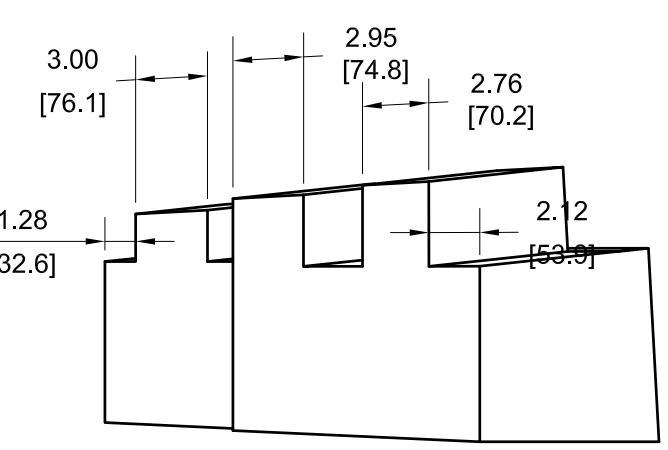

REPEATED VIEW D4-50 SHOWN FOR CLARITY PURPOSES

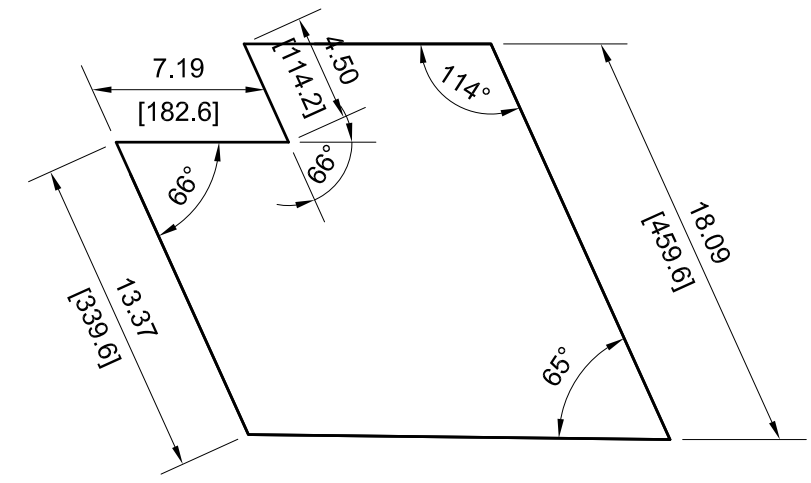
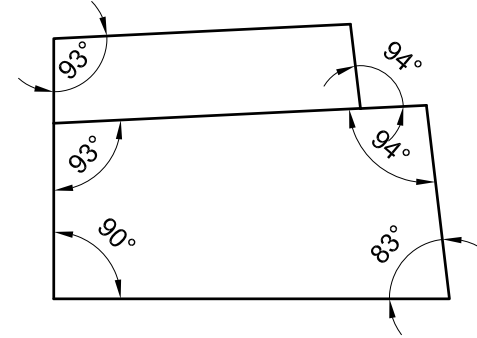
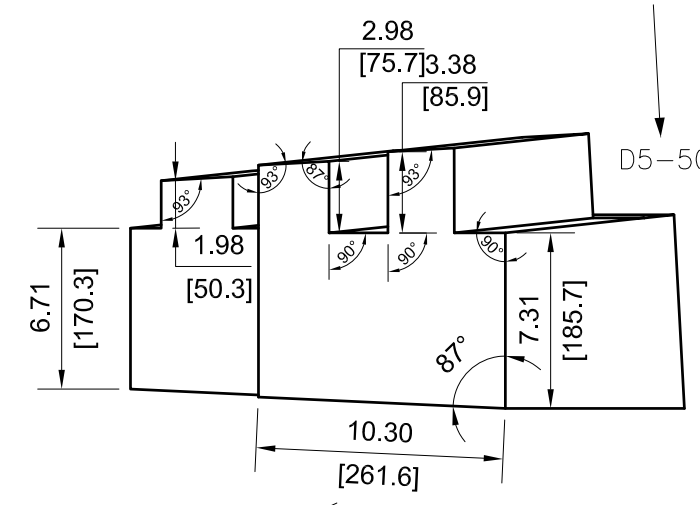
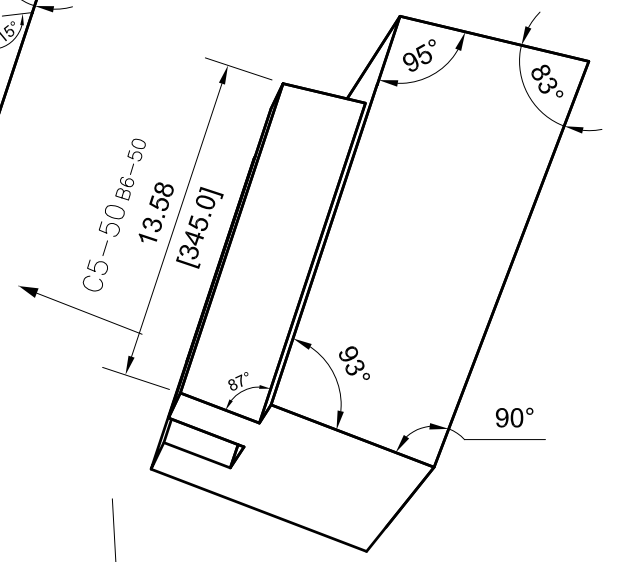
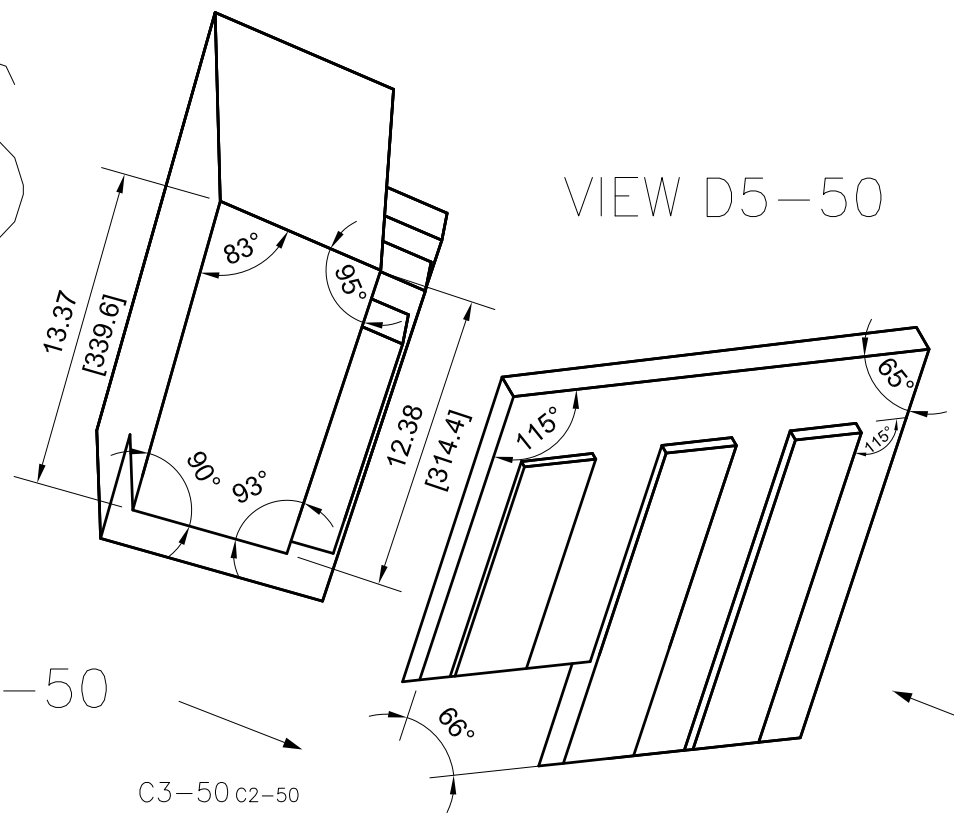

DRAWING NUMBER					AES-D0008	
SIZE	SCALE	SHEET	OF	REVISION		
A3	NONE	50	190	B		

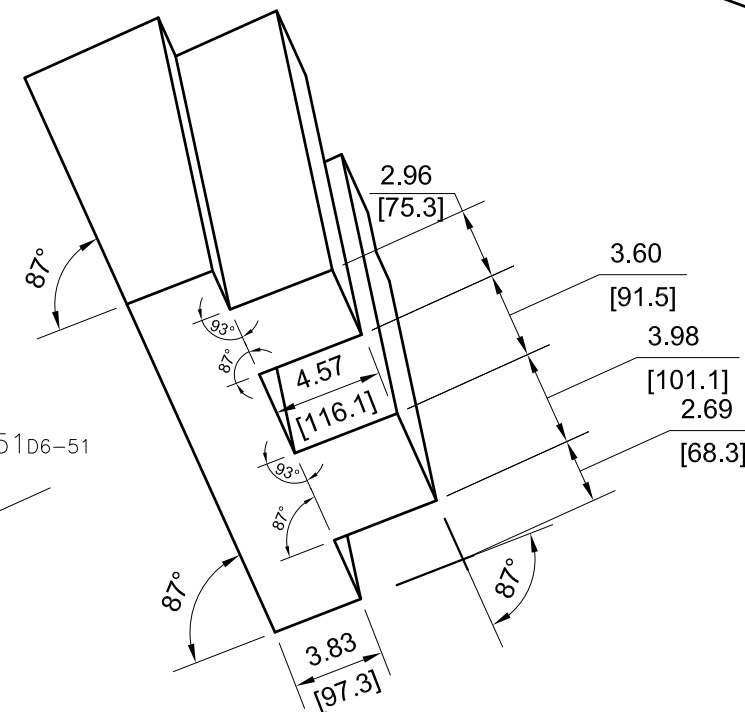
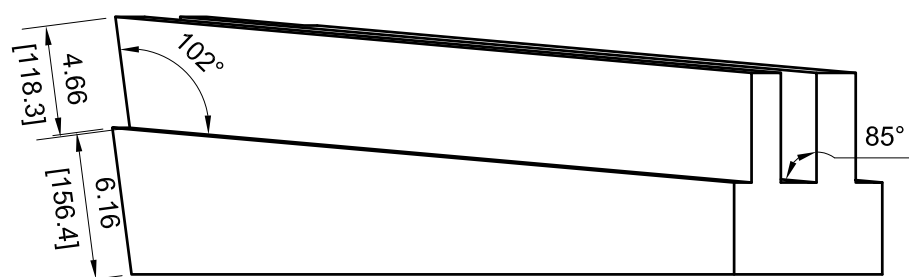
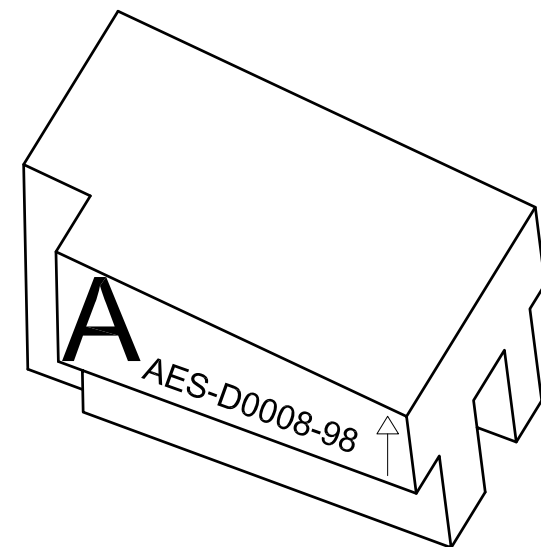
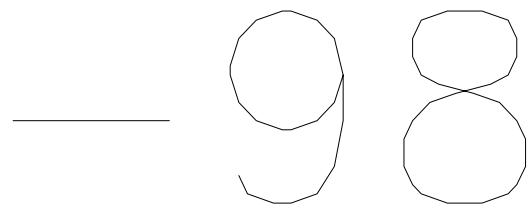

C2-51F1-51

C5-51D6-51

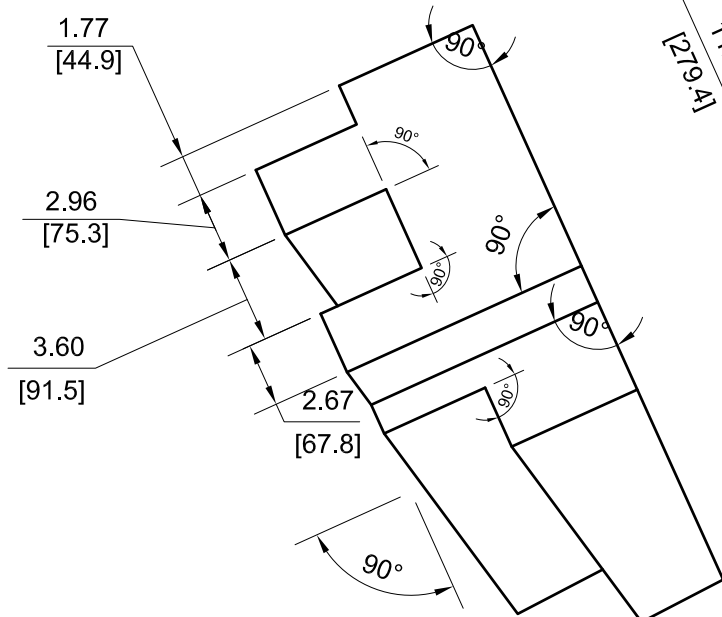
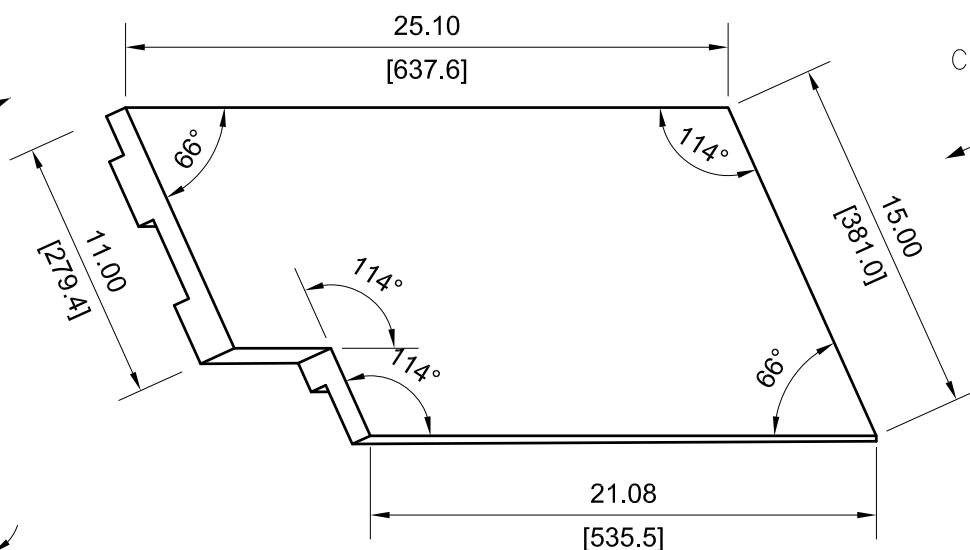

VIEW C2-51

VIEW C5-51

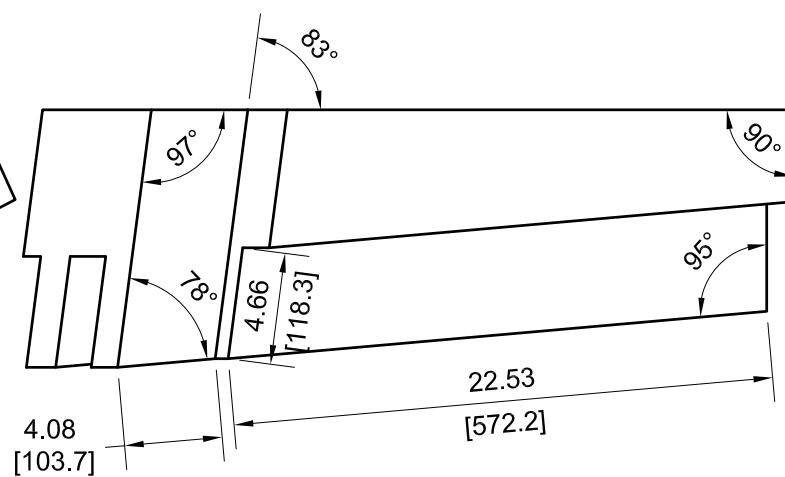

DRAWING NUMBER				
AES-D0008				
SIZE	SCALE	SHEET	OF	REVISION
A3	NONE	51	190	B

100

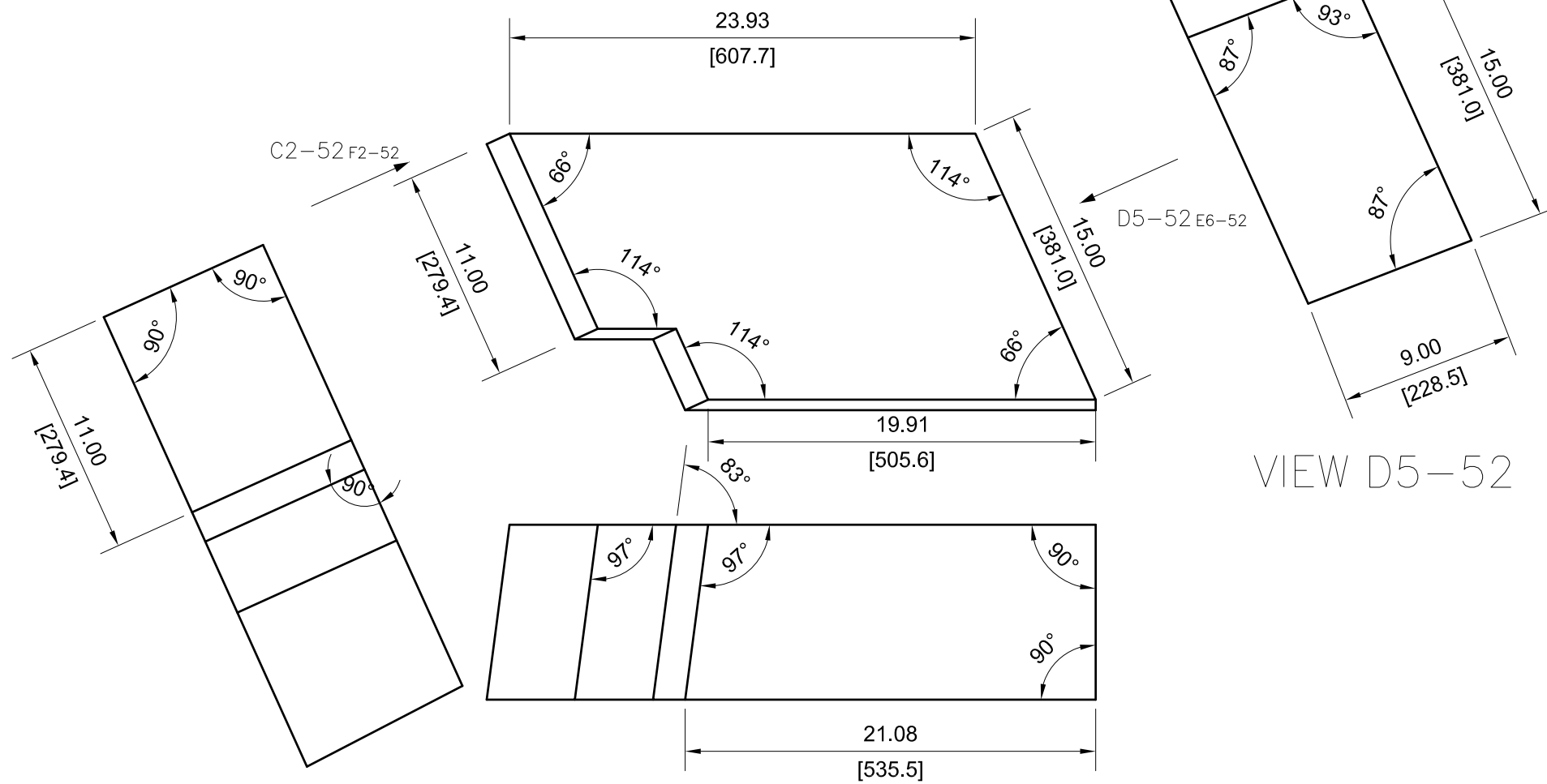
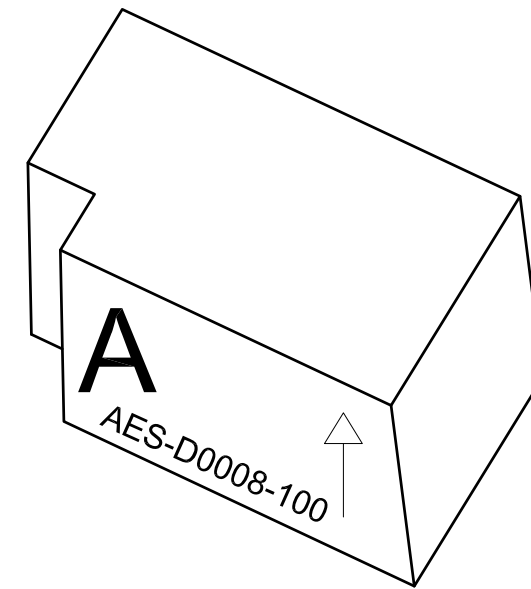

DRAWING NUMBER					AES-D0008	
SIZE	SCALE	SHEET	OF	REVISION		
A3	NONE	52	190	B		

— 102

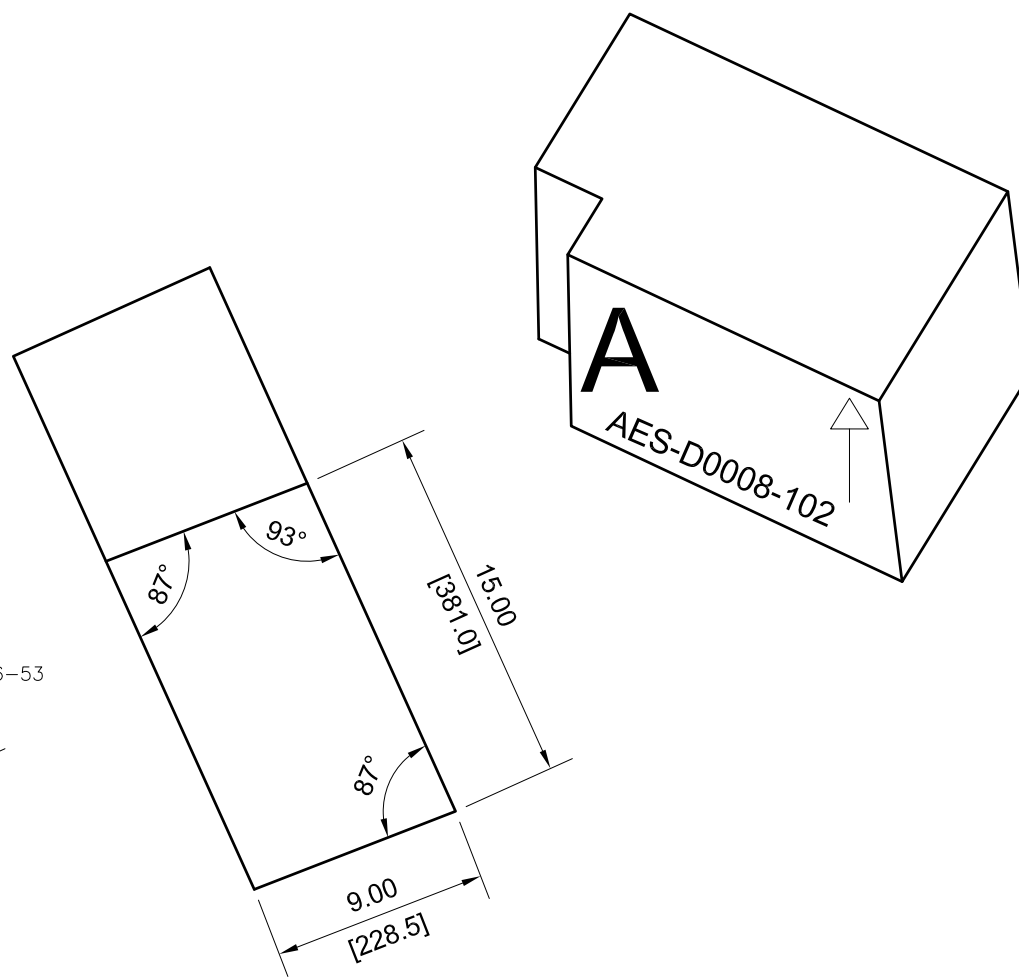
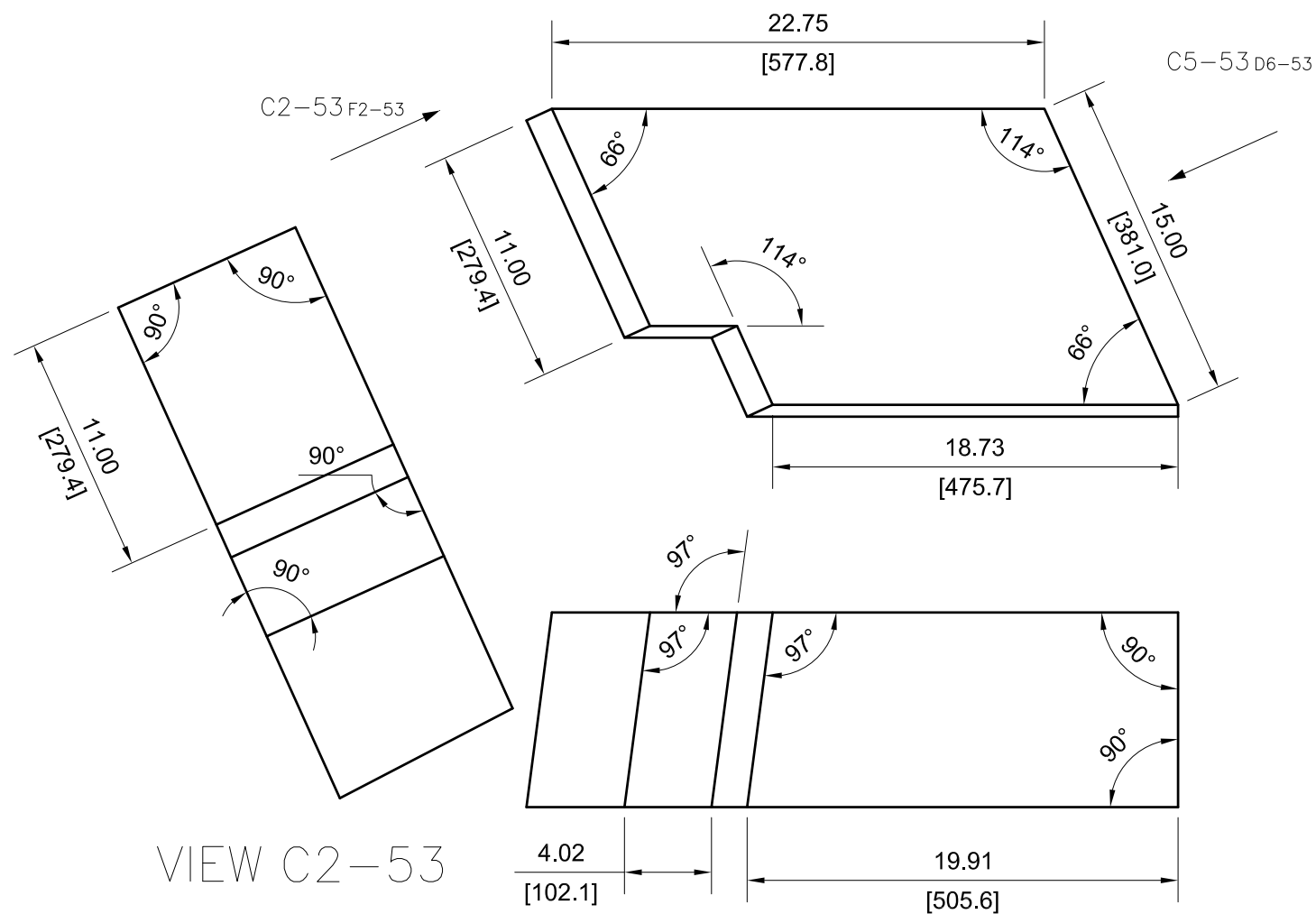

DRAWING NUMBER				
AES-D0008				
SIZE	SCALE	SHEET	OF	REVISION
A3	NONE	53	190	B

— 104

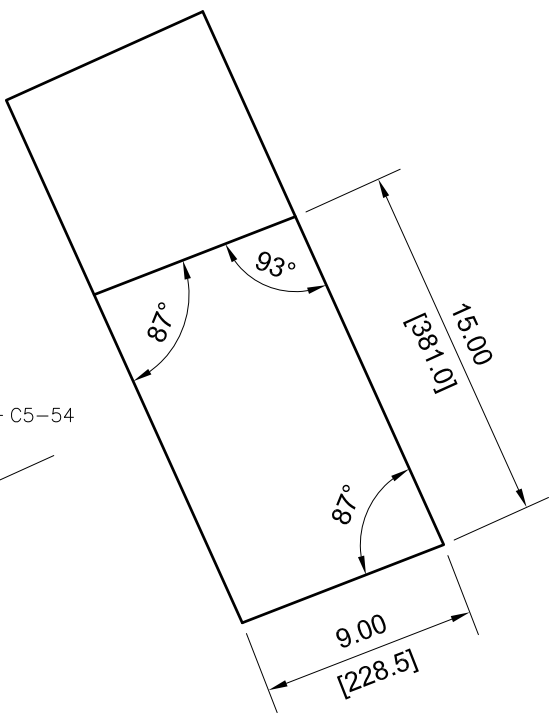
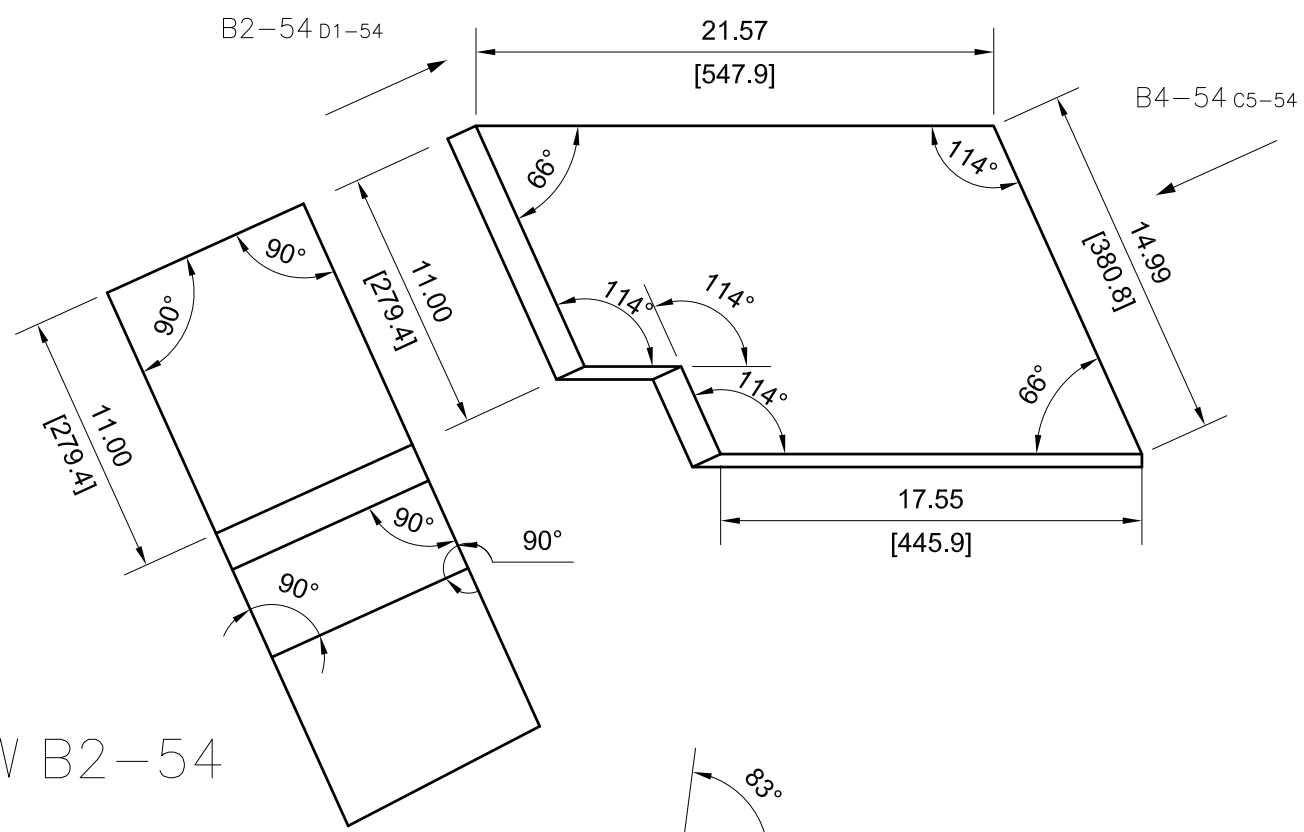

VIEW B4-54

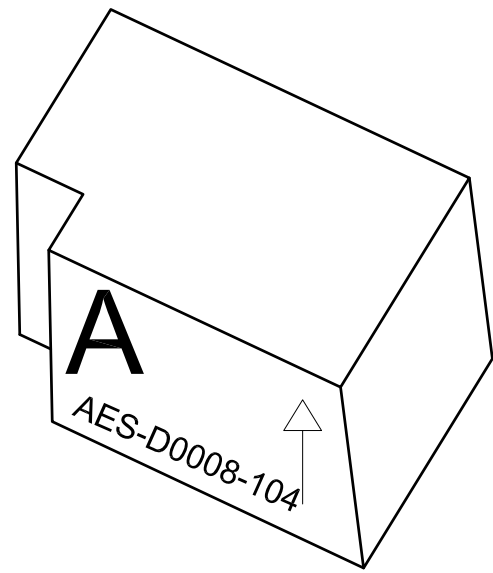

VIEW B2-54

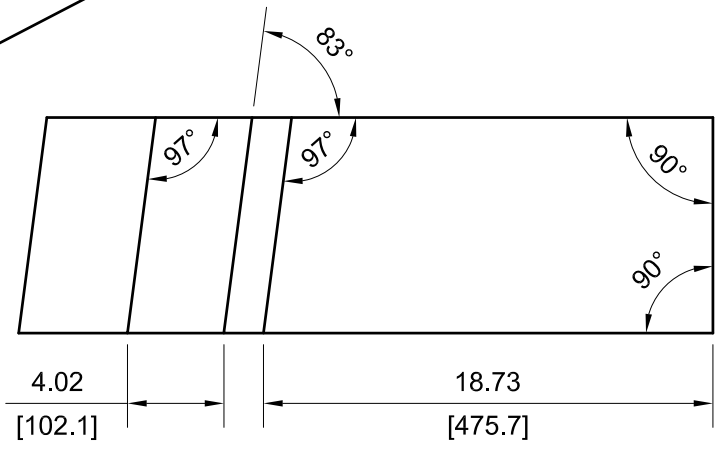

DRAWING NUMBER					AES-D0008	
SIZE	SCALE	SHEET	OF	REVISION		
A3	NONE	54	190	B		

1 2 3 4 5 6 7 8

A B C D E F

106

B2-55 E2-55

B4-55 C5-55

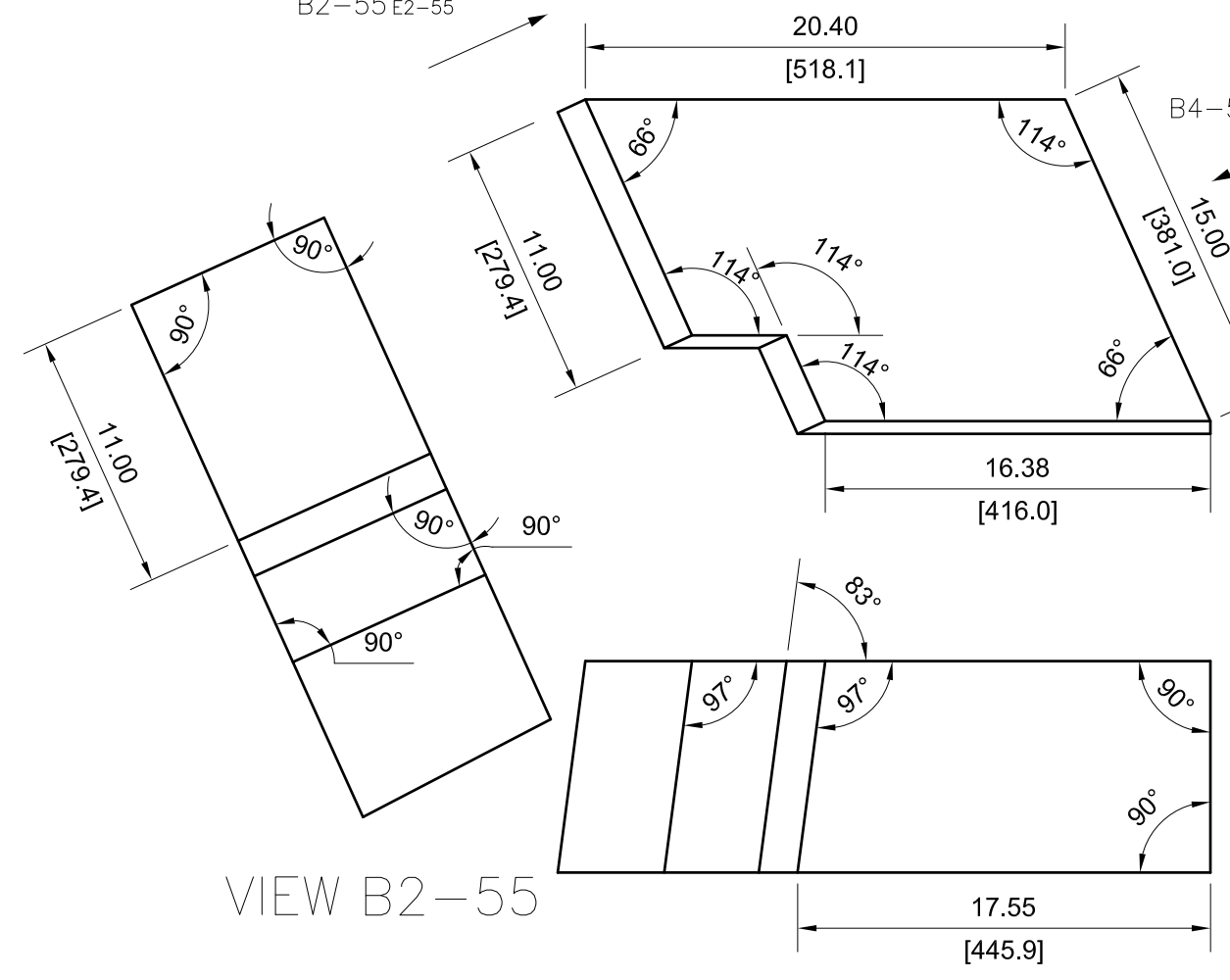

VIEW B2-55

VIEW B4-55

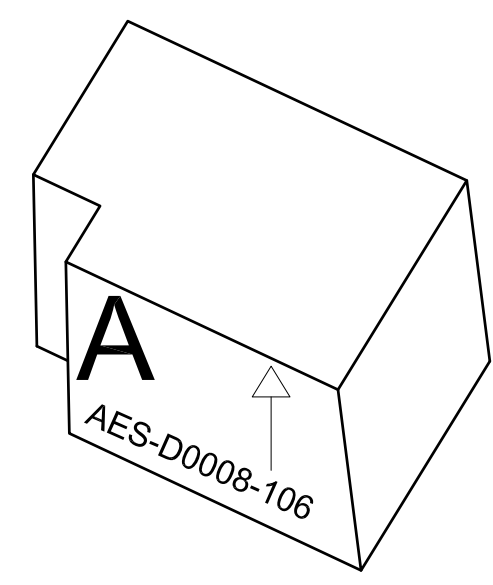

DRAWING NUMBER					AES-D0008	
SIZE	SCALE	SHEET	OF	REVISION		
A3	NONE	55	190	B		

1 2 3 4 5 6 7 8

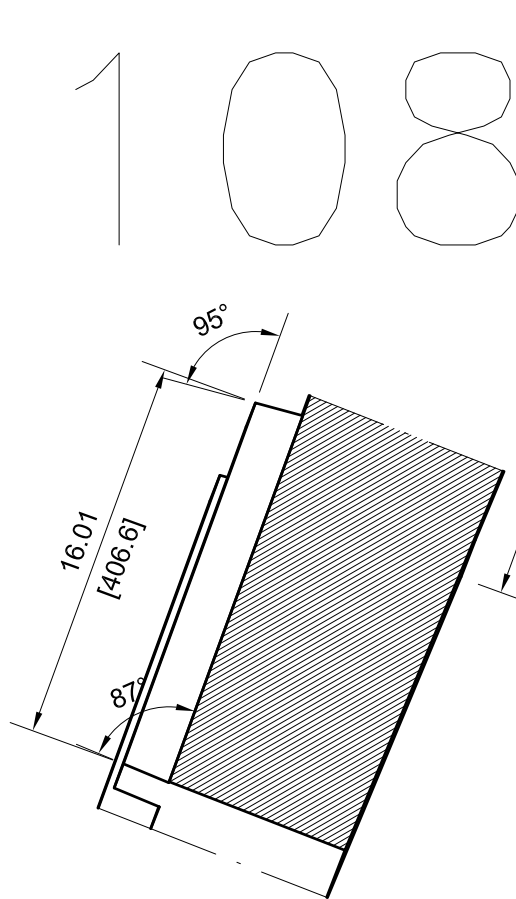

SECTION VIEW B4-56

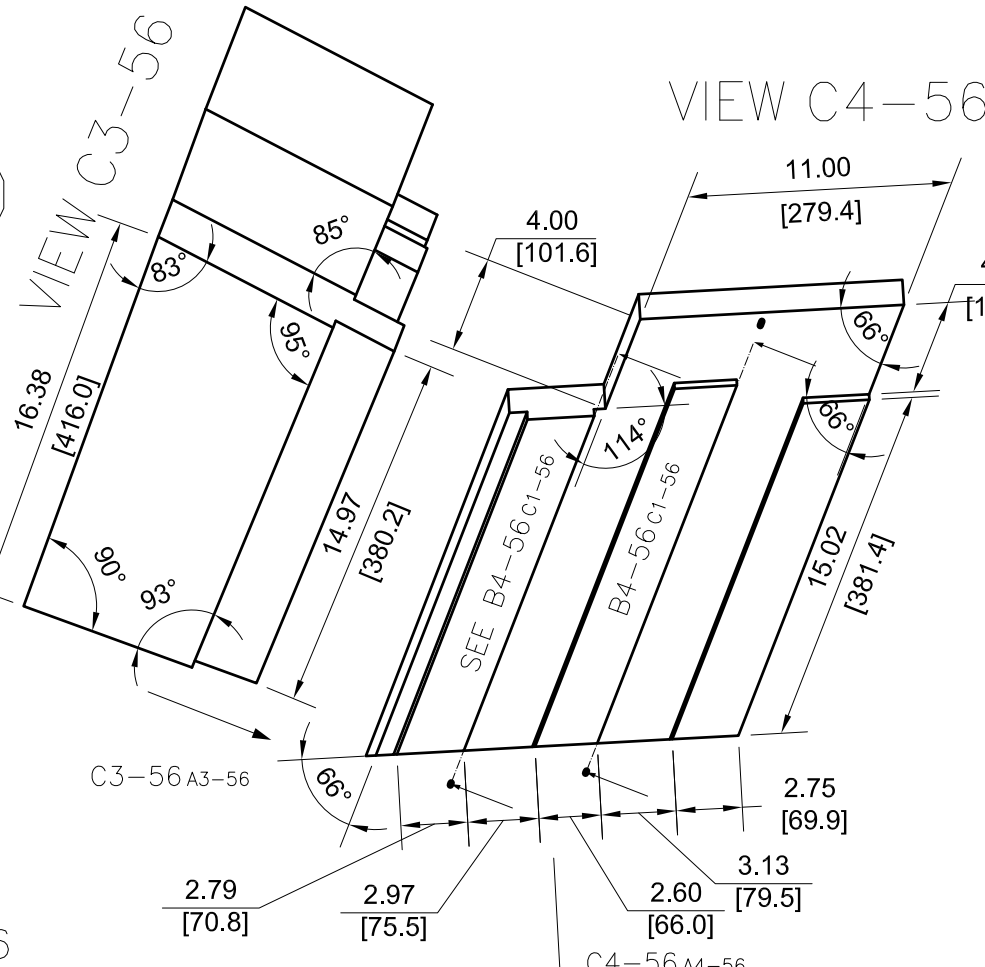

VIEW C4-56

VIEW C3-56

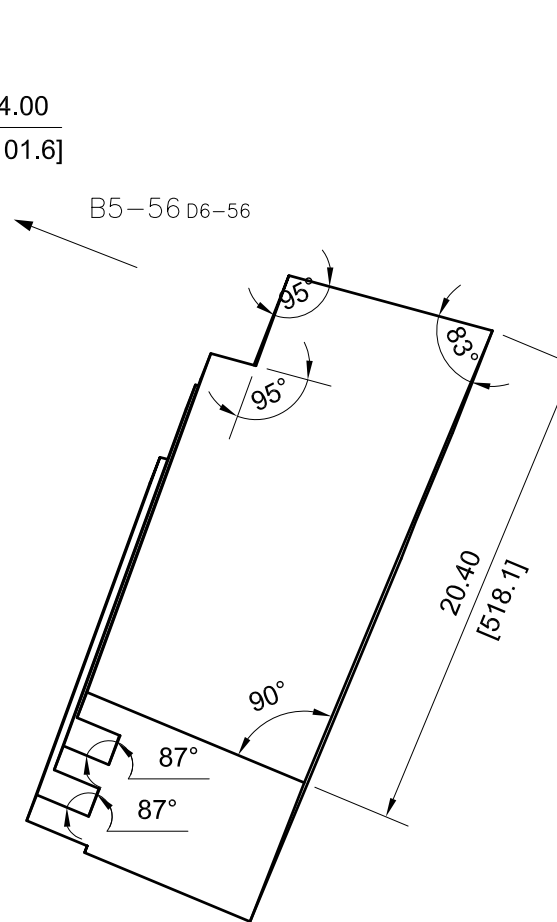

VIEW B5-56

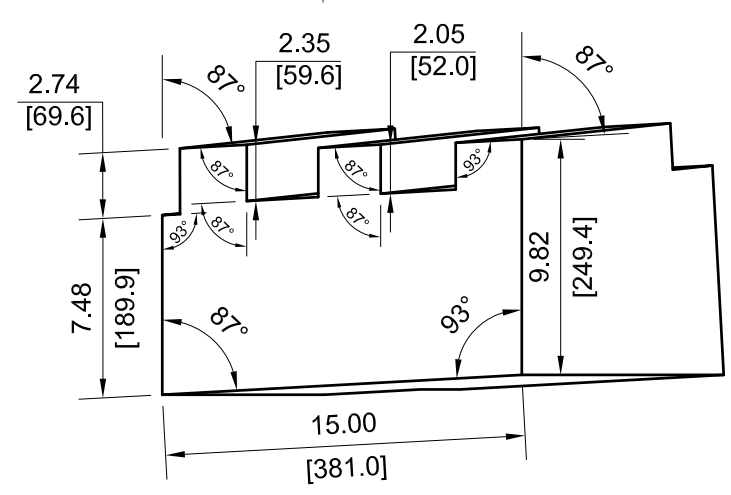
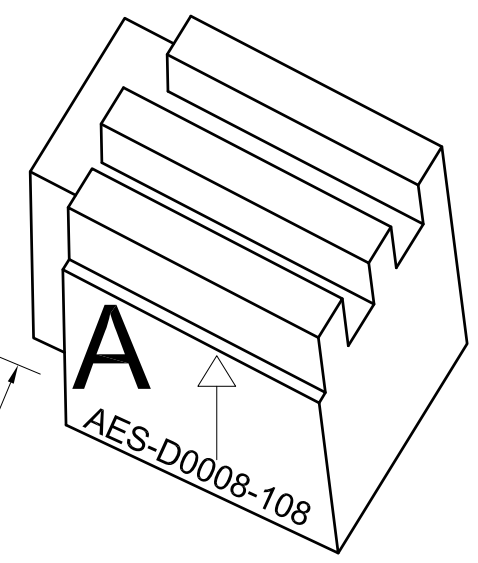

VIEW C4-56 A4-56

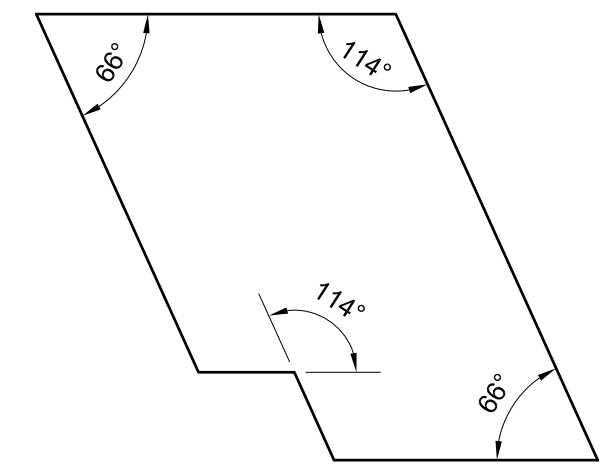
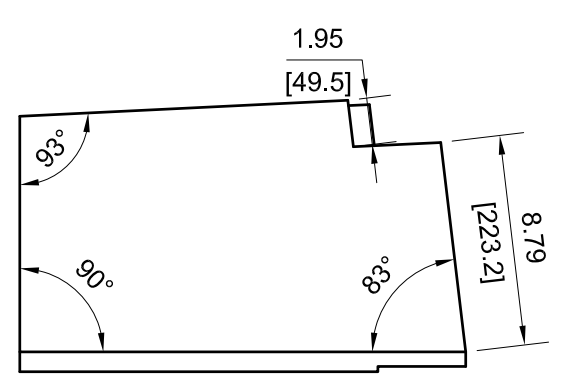

	DRAWING NUMBER				
	AES-D0008				
SIZE	SCALE	SHEET	OF	REVISION	
A3	NONE	56	190	B	

110

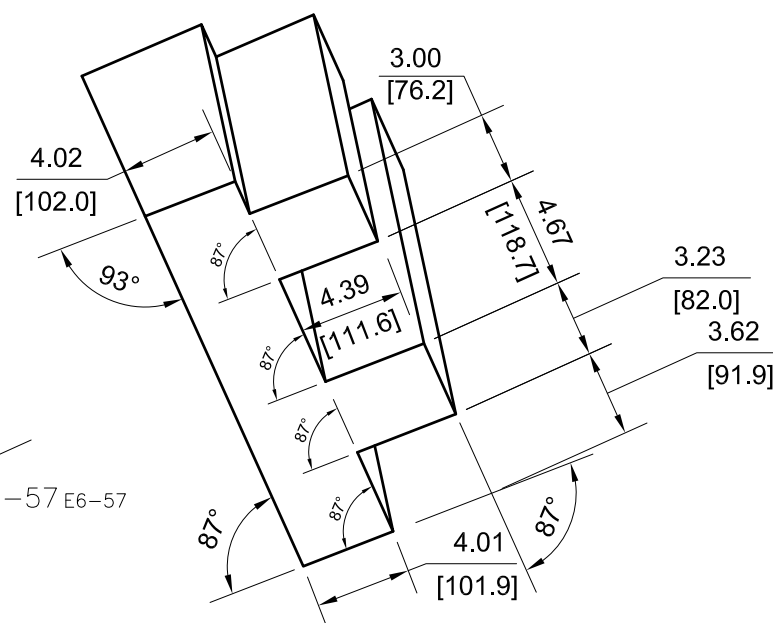
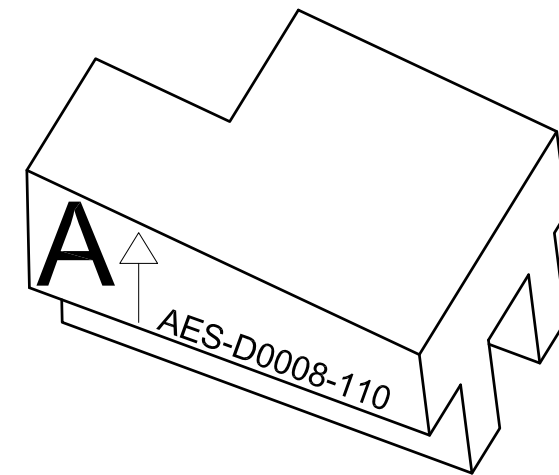
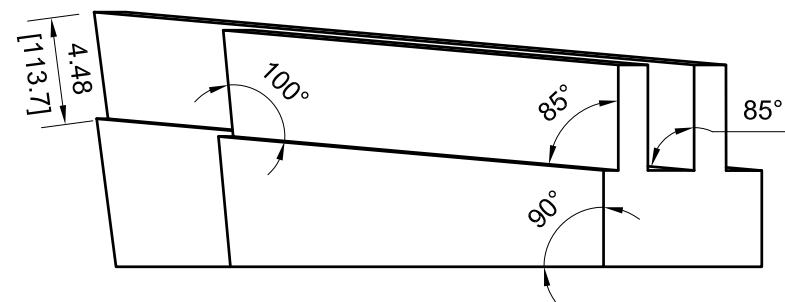

VIEW D5-57

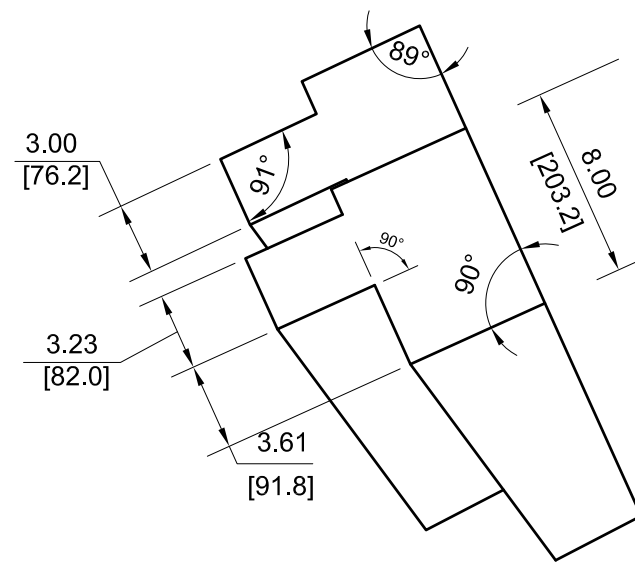
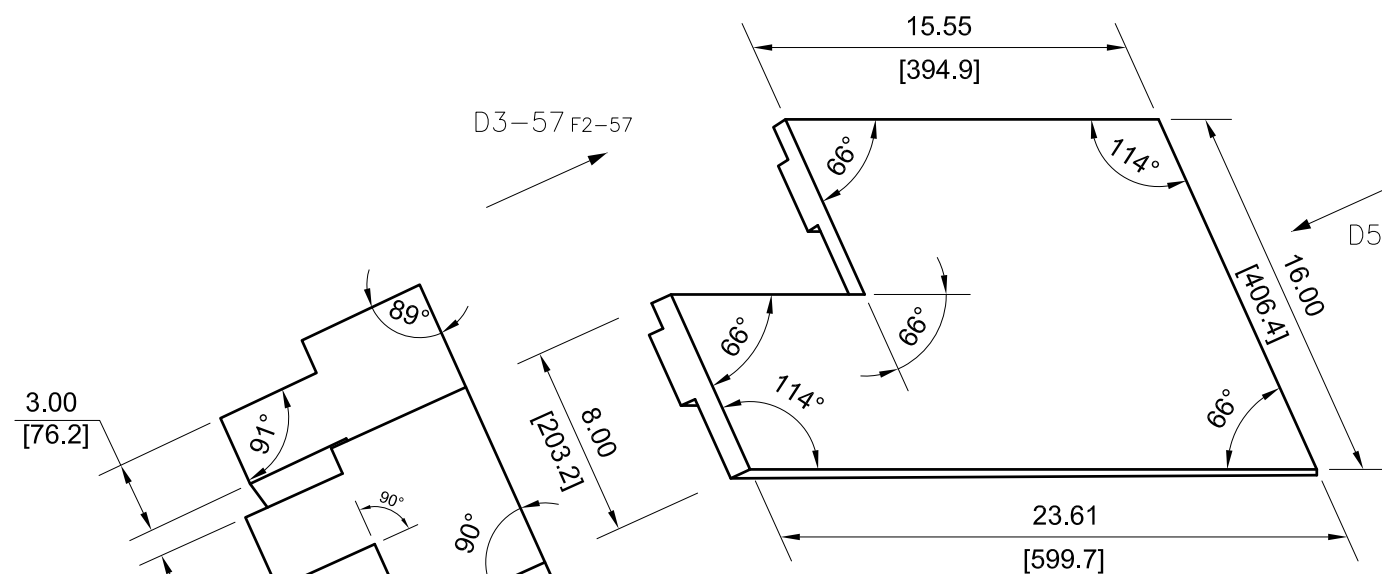

VIEW D3-57

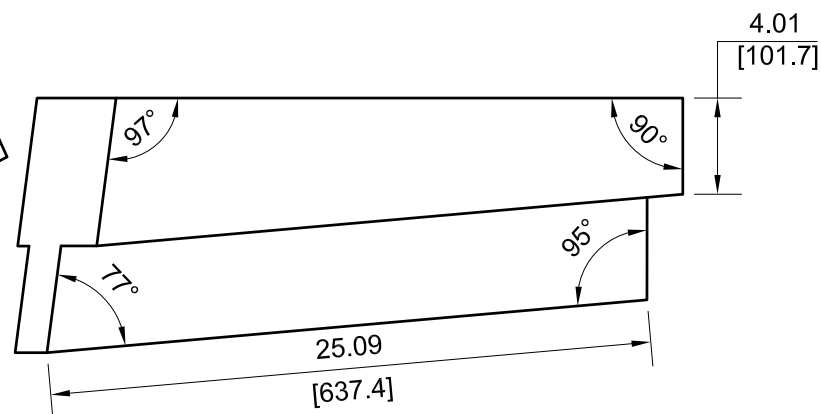

DRAWING NUMBER				
AES-D0008				
SIZE	SCALE	SHEET	OF	REVISION
A3	NONE	57	190	B

-112

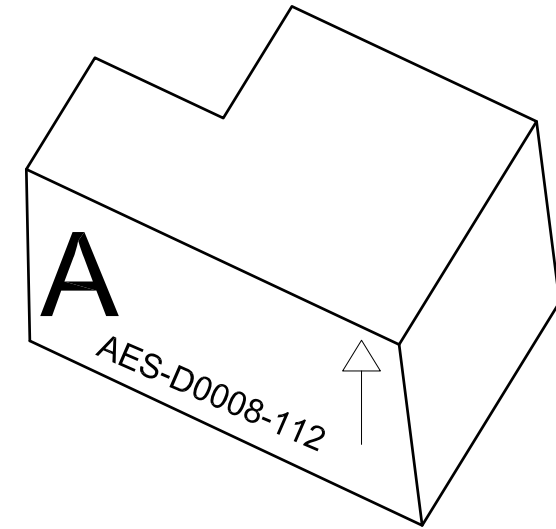
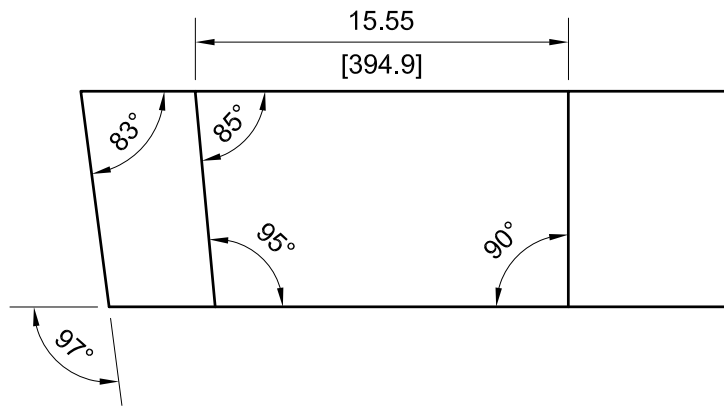

D2-58 F1-58

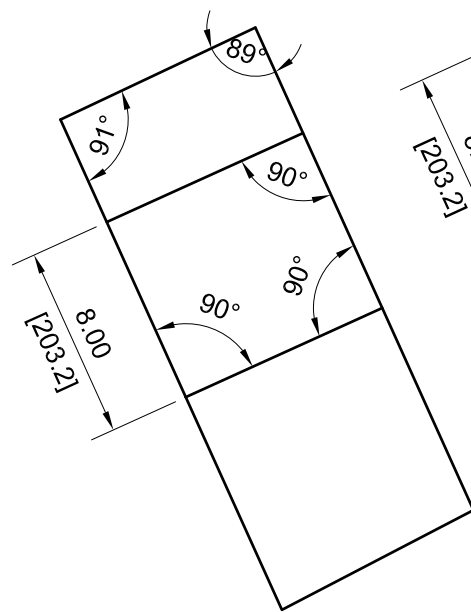

VIEW D2-58

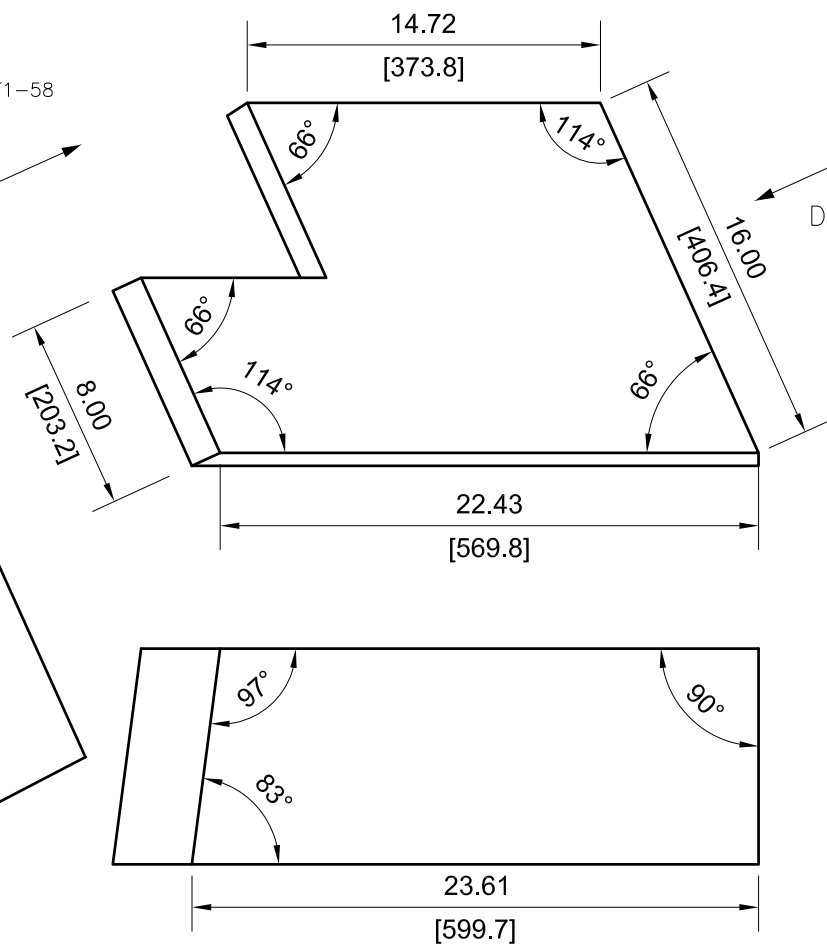

D4-58 E5-58

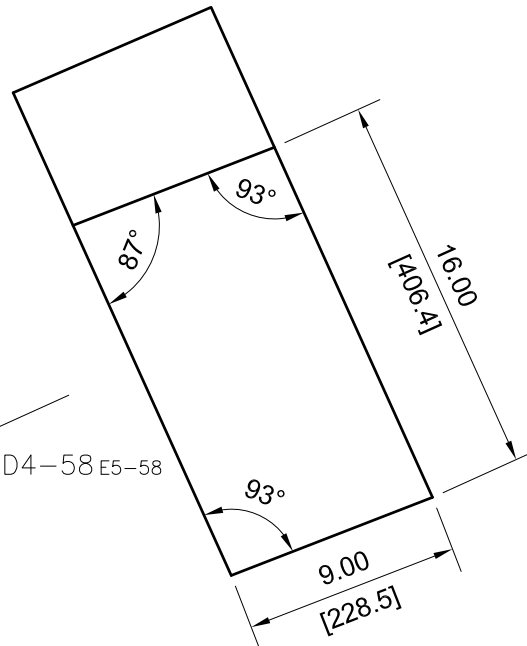

VIEW D4-58



DRAWING NUMBER					AES-D0008				
SIZE	SCALE	SHEET	OF	REVISION					
A3	NONE	58	190	B					

114

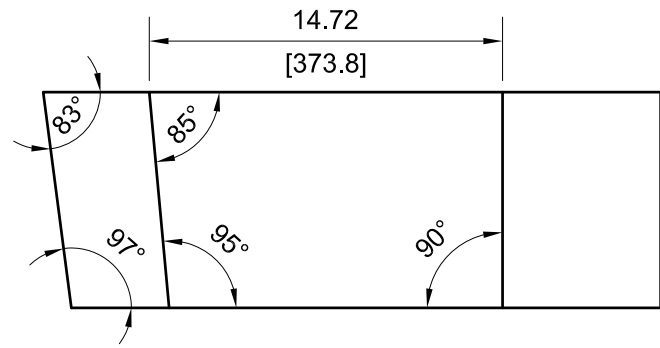

C2-59 E1-59

C4-59 D5-59

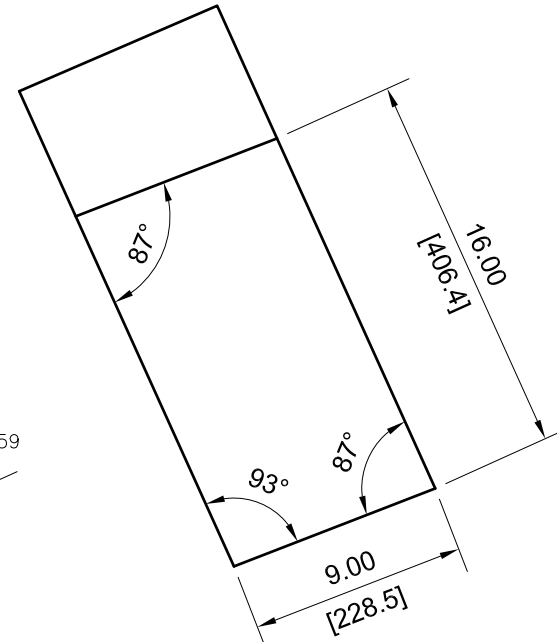
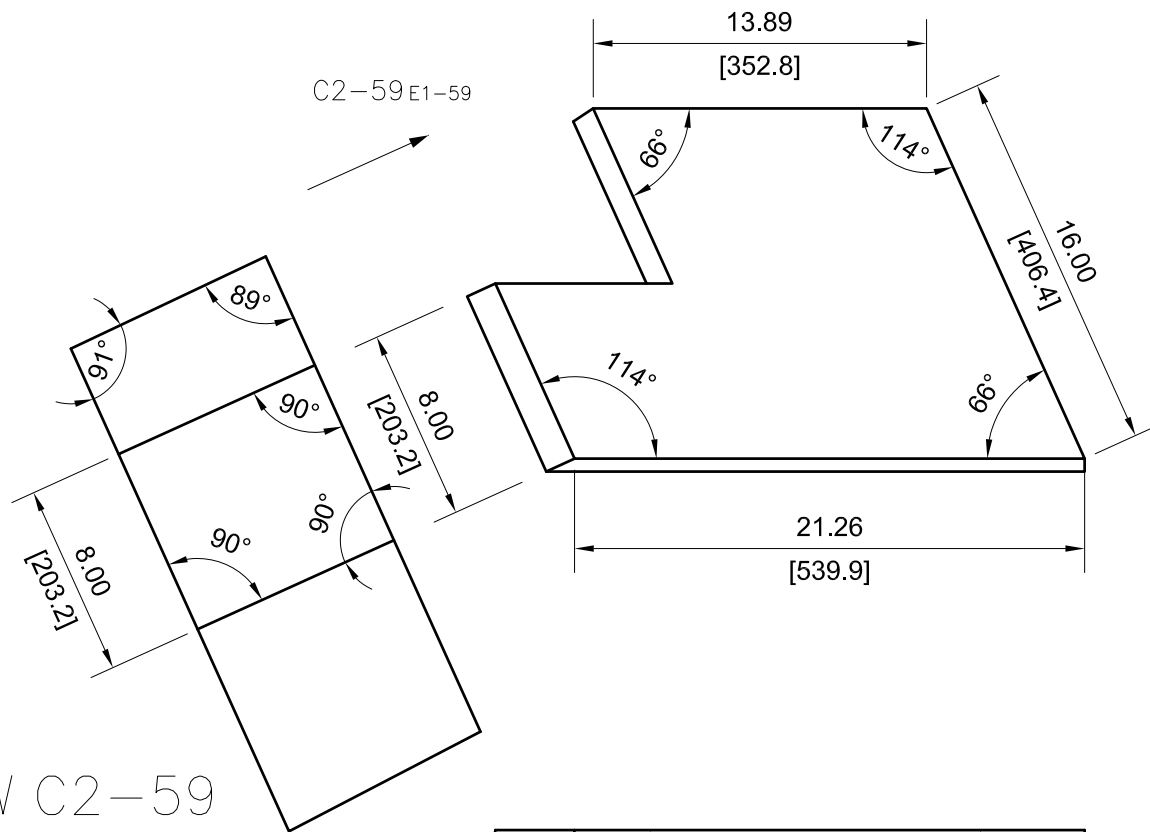

VIEW C4-59

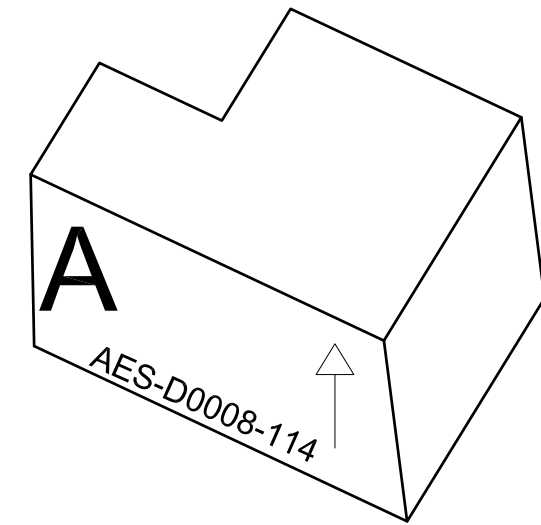

VIEW C2-59

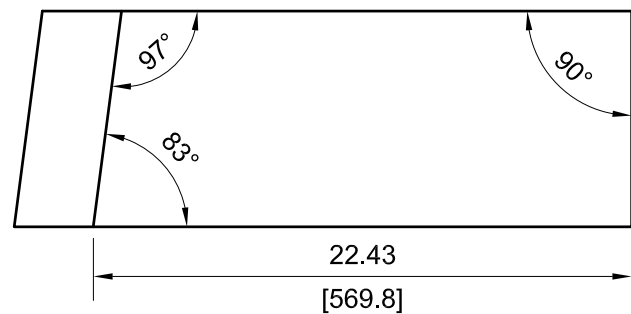

DRAWING NUMBER				
AES-D0008				
SIZE	SCALE	SHEET	OF	REVISION
A3	NONE	59	190	B

116

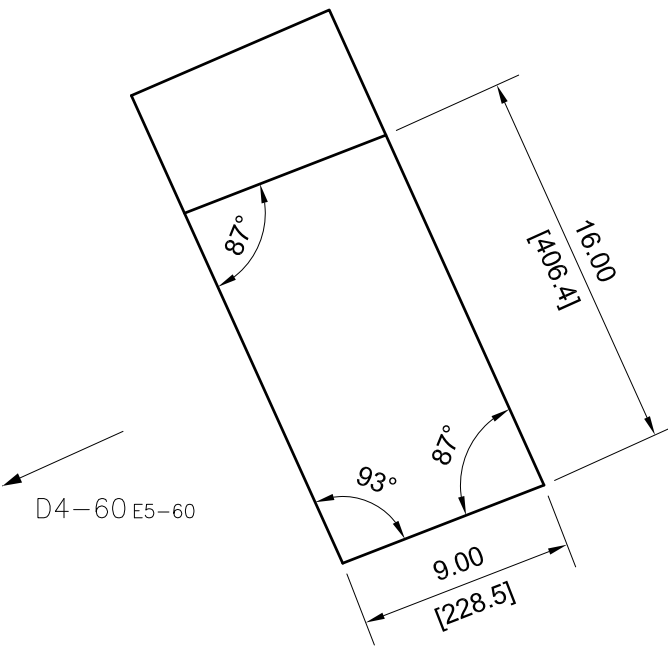
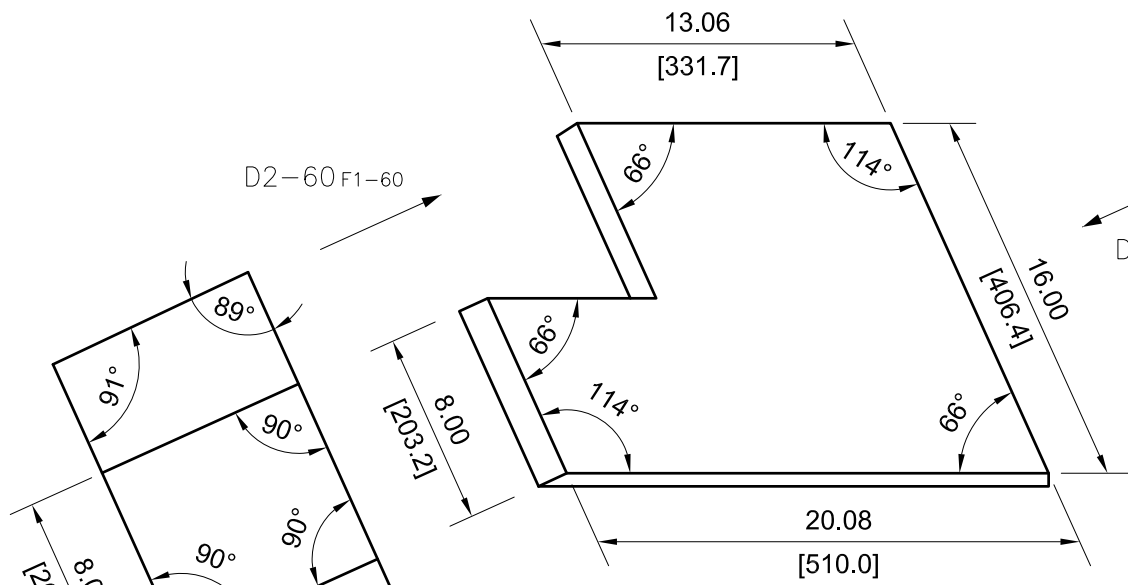
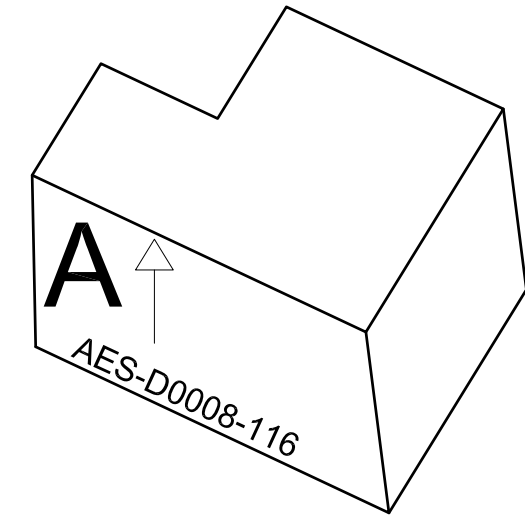
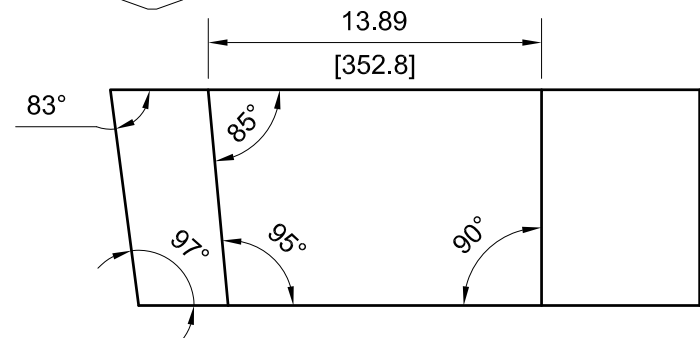

VIEW D4-60

VIEW D2-60

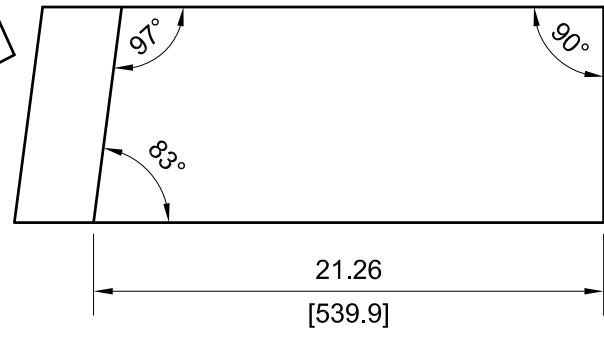

DRAWING NUMBER				
AES-D0008				
SIZE	SCALE	SHEET	OF	REVISION
A3	NONE	60	190	B

— 118

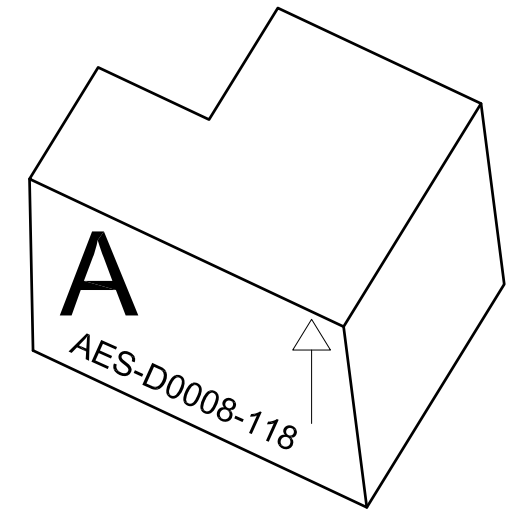
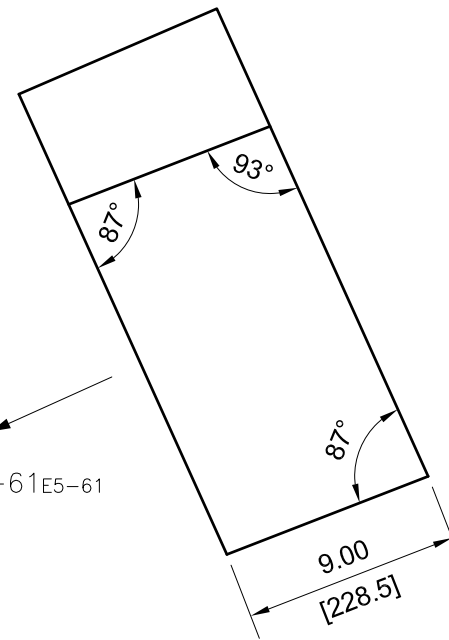
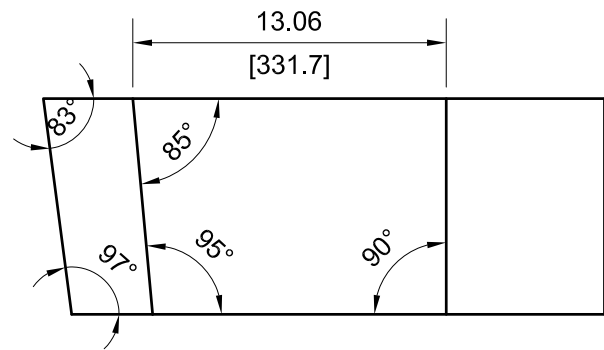

D2-61F1-61

D4-61E5-61

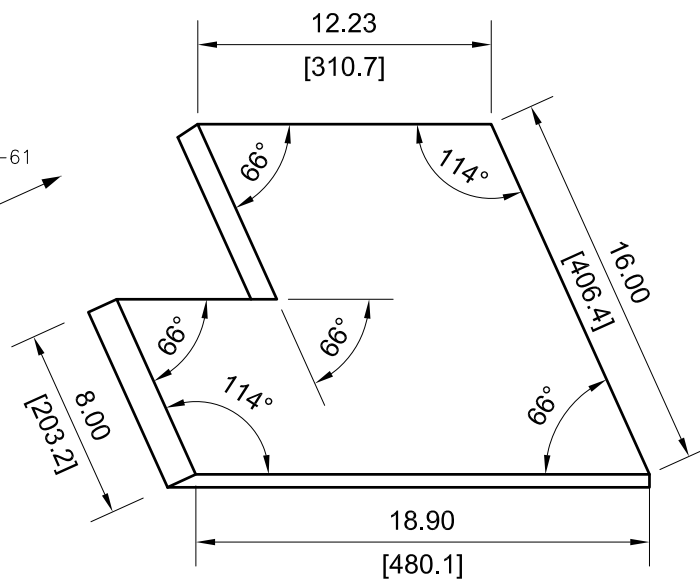

VIEW D4-61

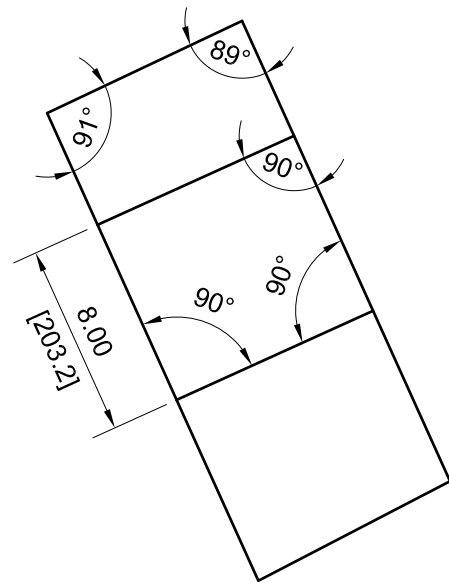

VIEW D2-61



DRAWING NUMBER					AES-D0008	
SIZE	SCALE	SHEET	OF	REVISION		
A3	NONE	61	190	B		

120

VIEW A4-62

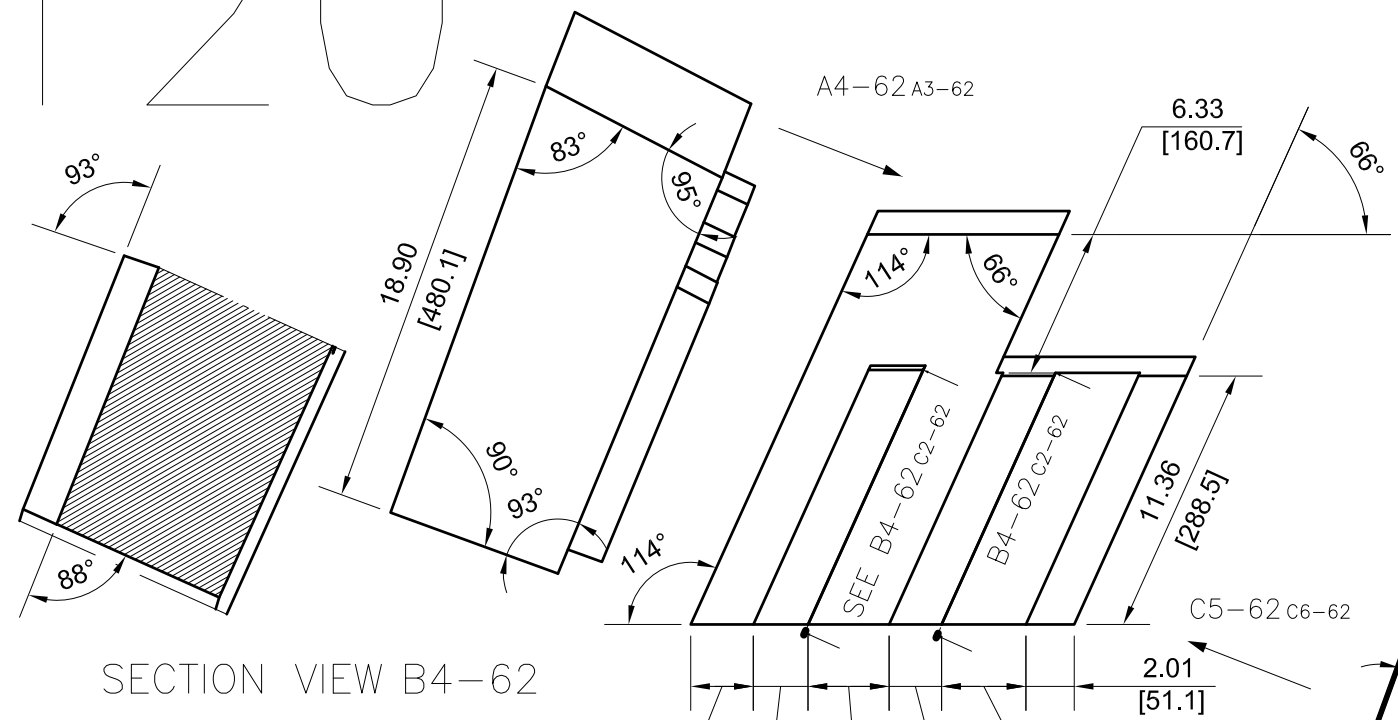

SECTION VIEW B4-62

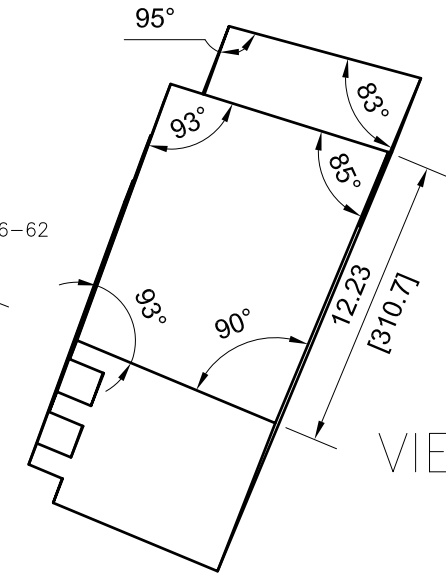
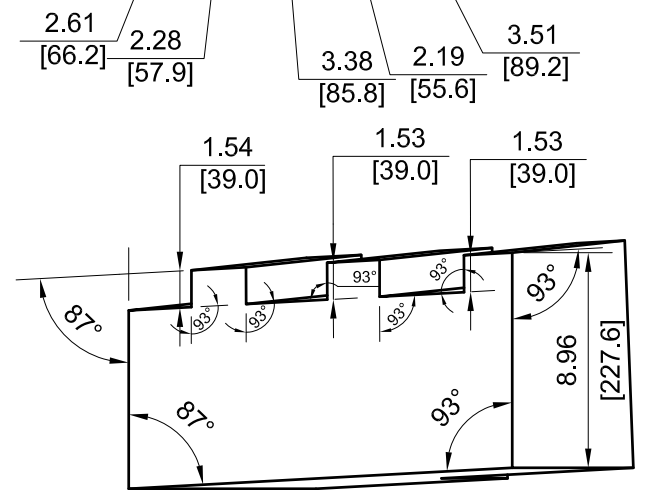

VIEW C5-62

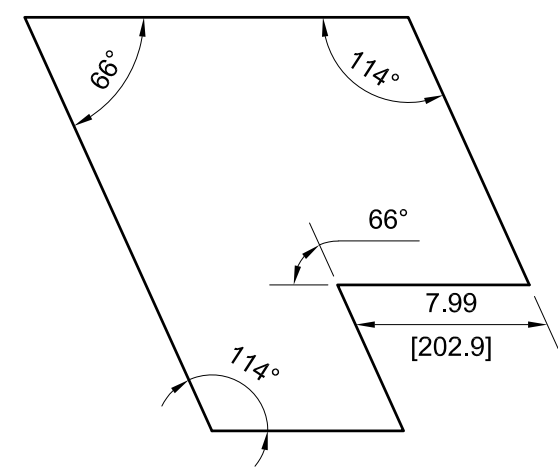
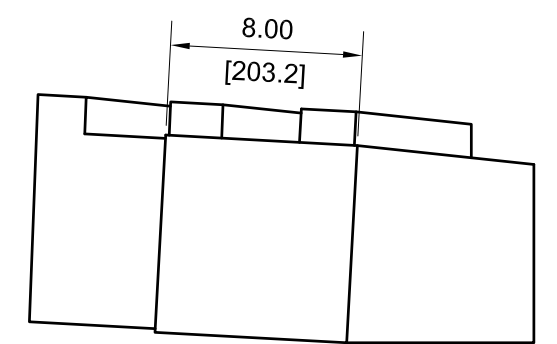
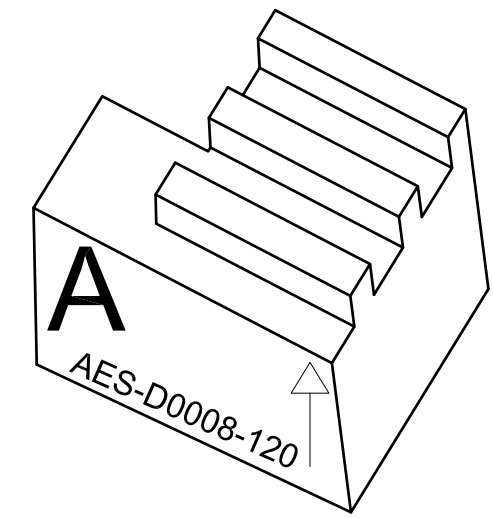

DRAWING NUMBER					AES-D0008				
SIZE	SCALE	SHEET	OF	REVISION					
A3	NONE	62	190	B					

122

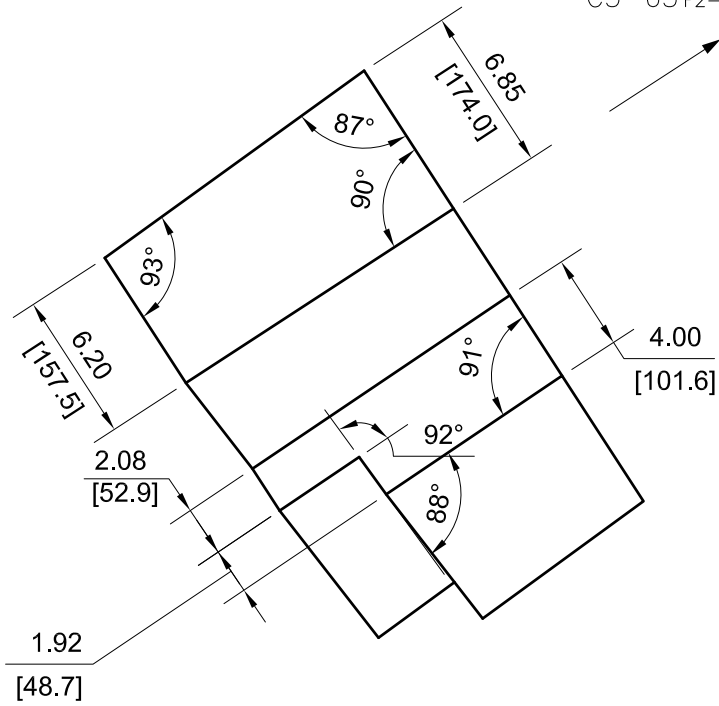
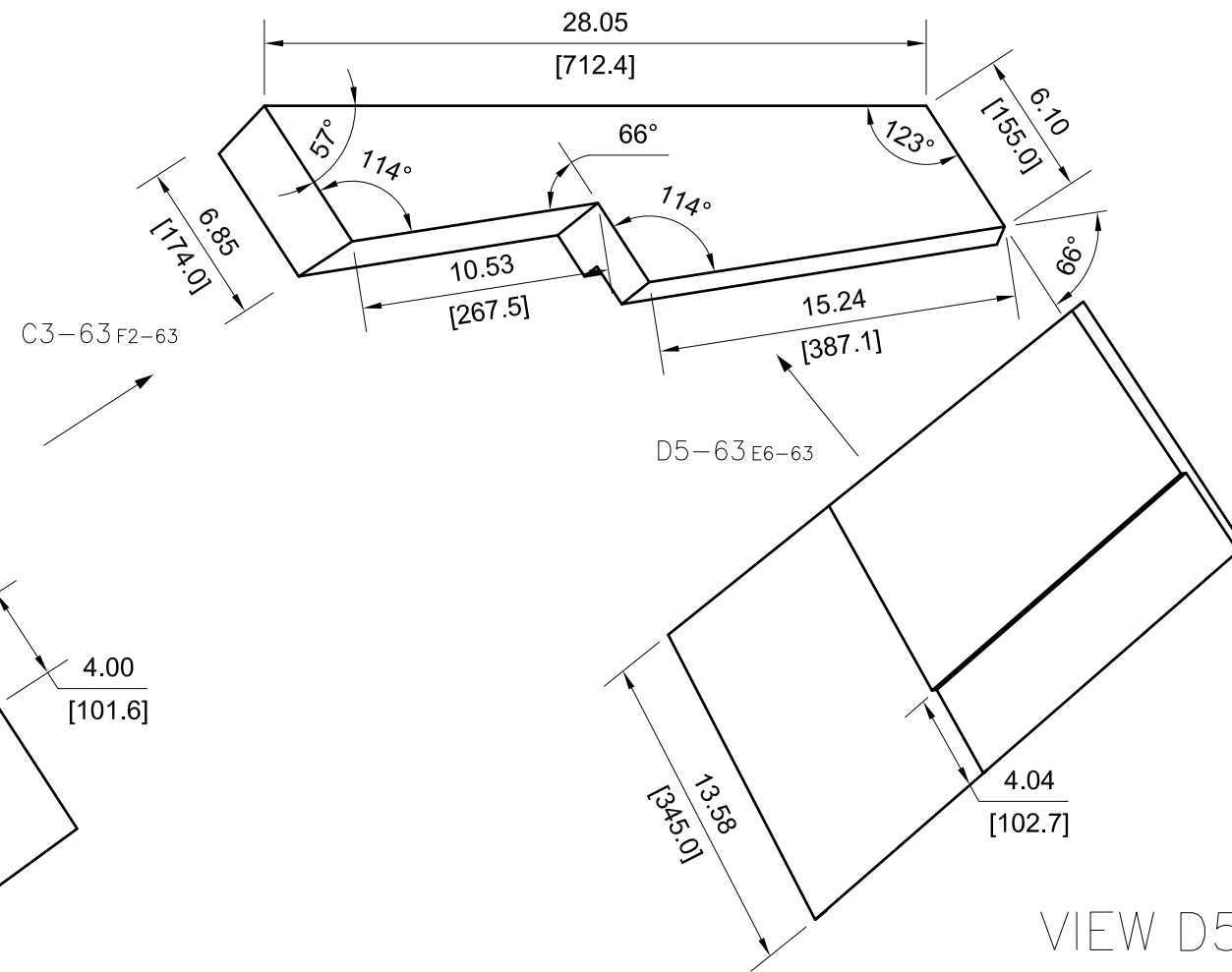
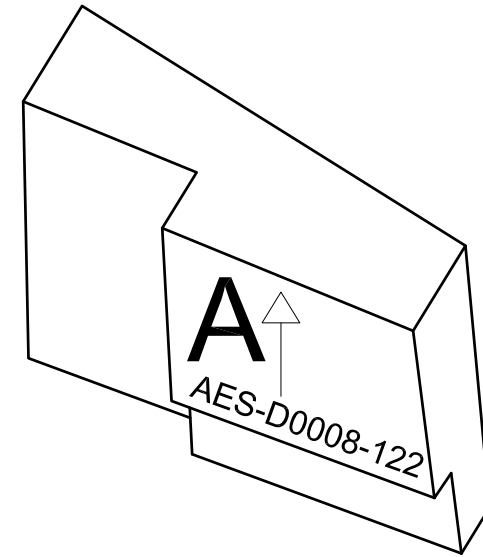
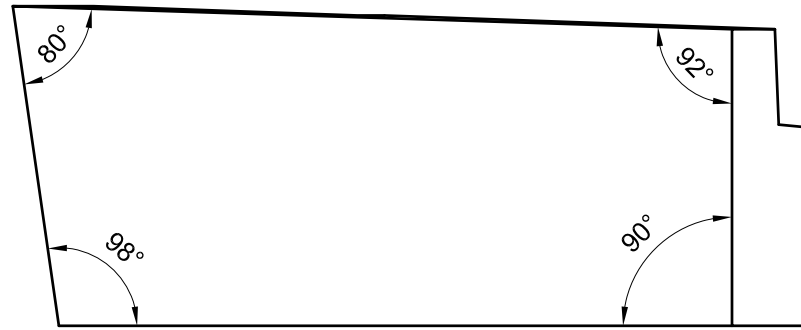

VIEW C3-63

VIEW D5-63

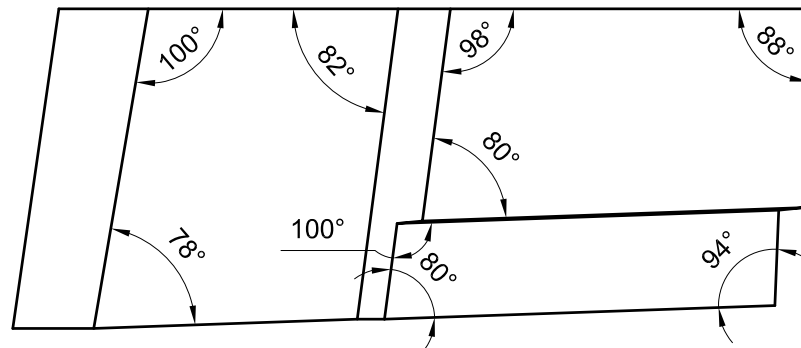

DRAWING NUMBER					AES-D0008				
SIZE	SCALE	SHEET	OF	REVISION					
A3	NONE	63	190	B					

124

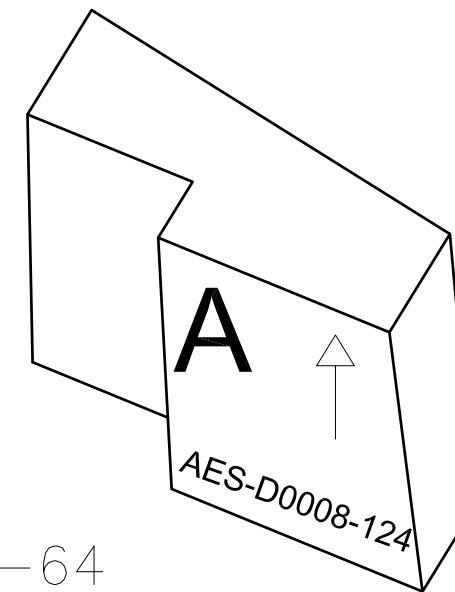
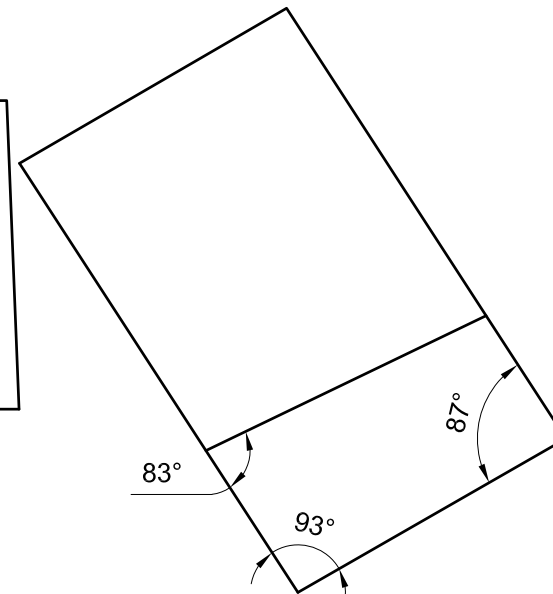

VIEW C6-64

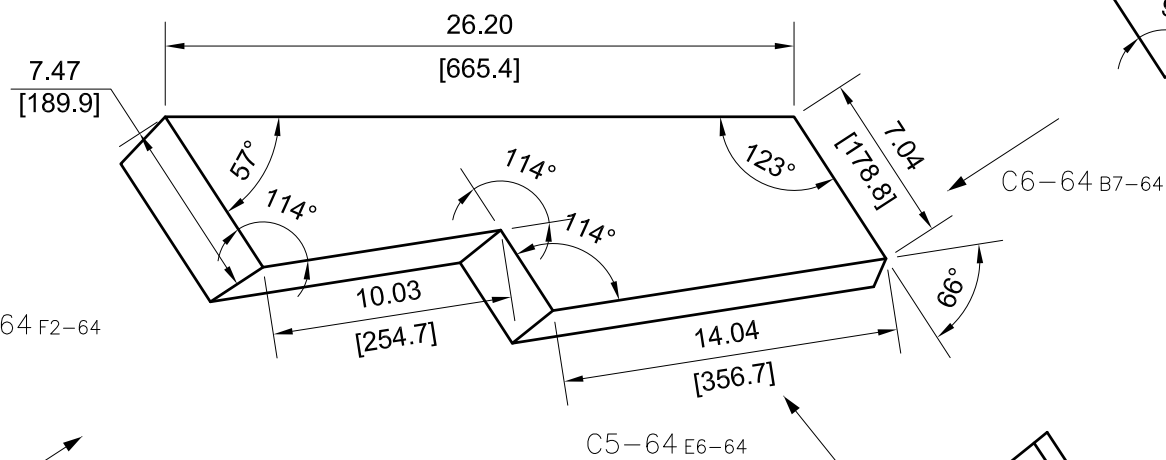

C3-64 F2-64

C6-64 B7-64

C5-64 E6-64

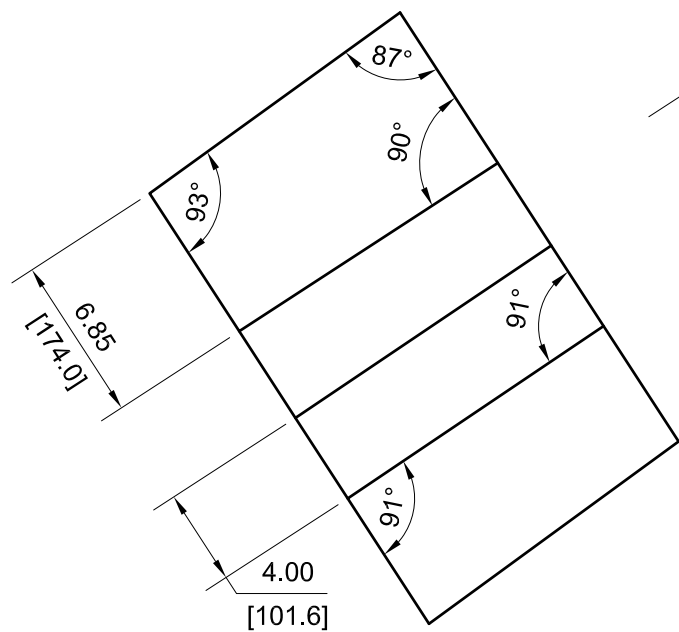

VIEW C3-64

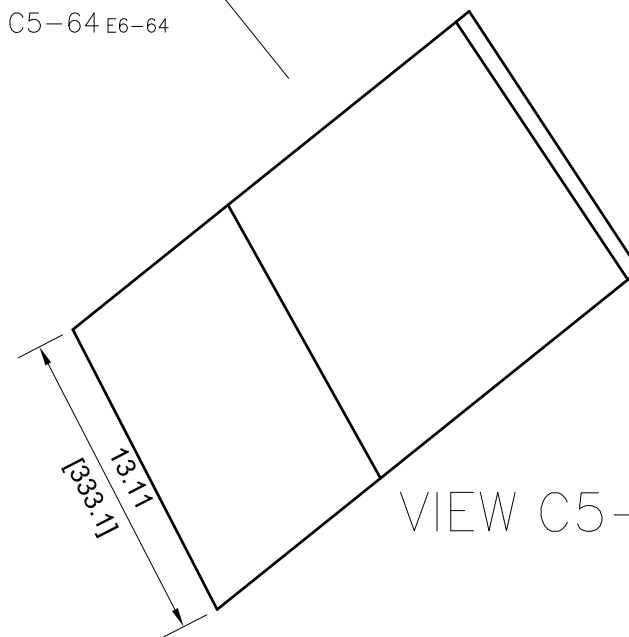

VIEW C5-64

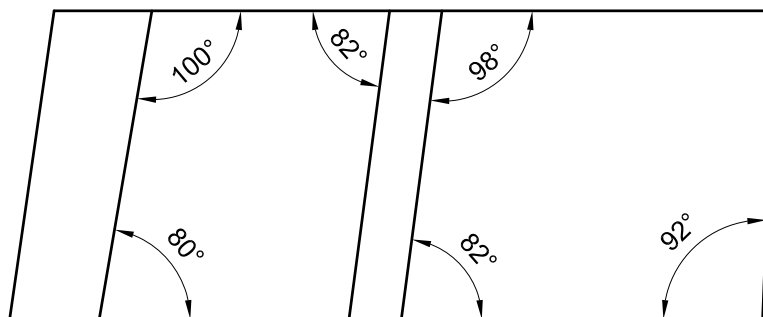

DRAWING NUMBER				
AES-D0008				
SIZE	SCALE	SHEET	OF	REVISION
A3	NONE	64	190	B

126

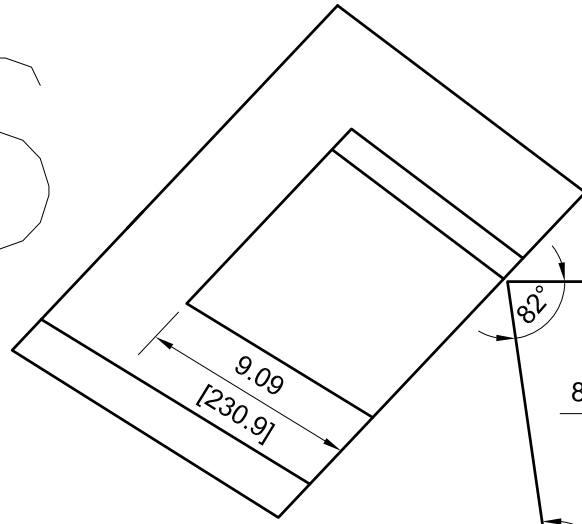

VIEW D3-65

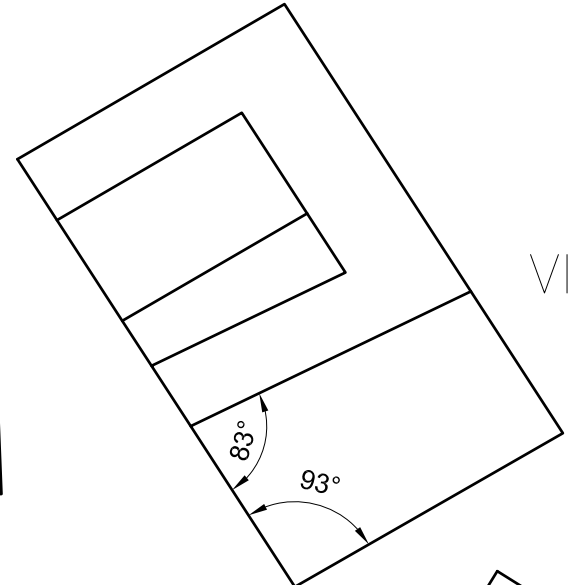
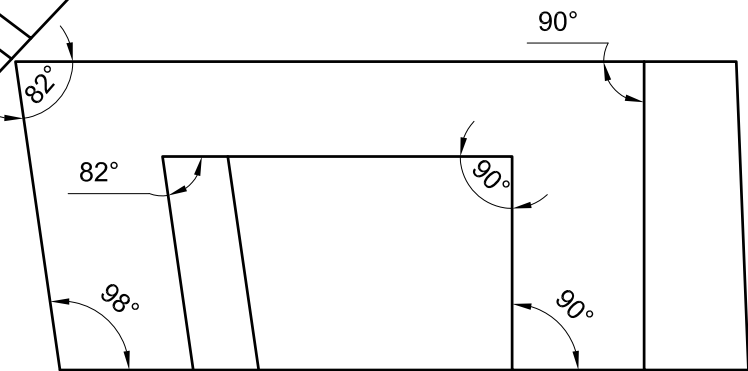

VIEW C6-65

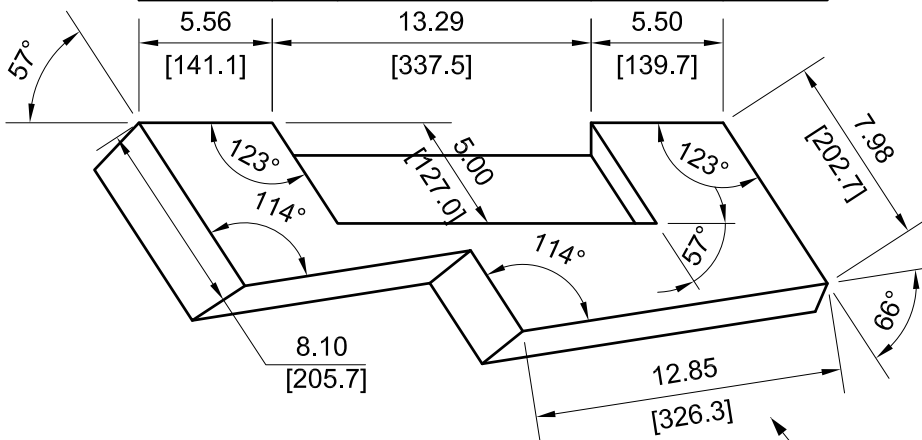

D3-65 B3-65

C6-65 B7-65

D6-65 F6-65

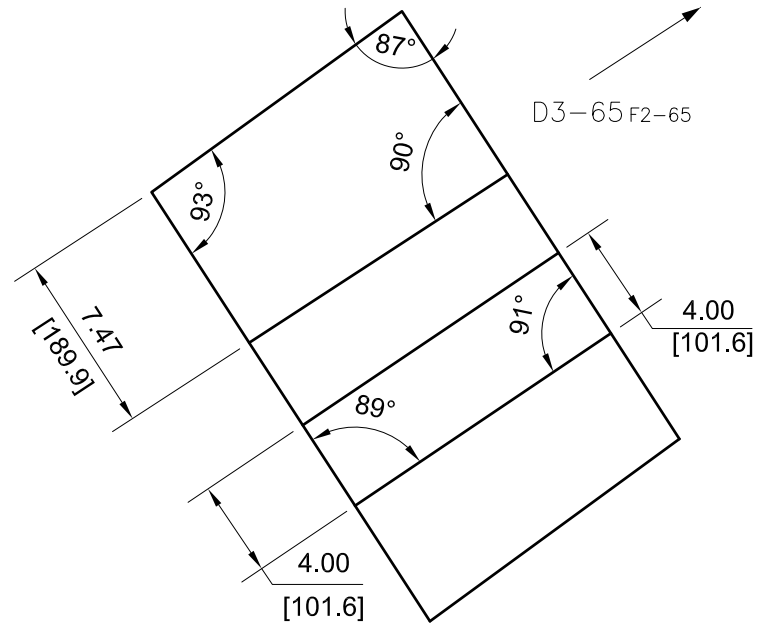
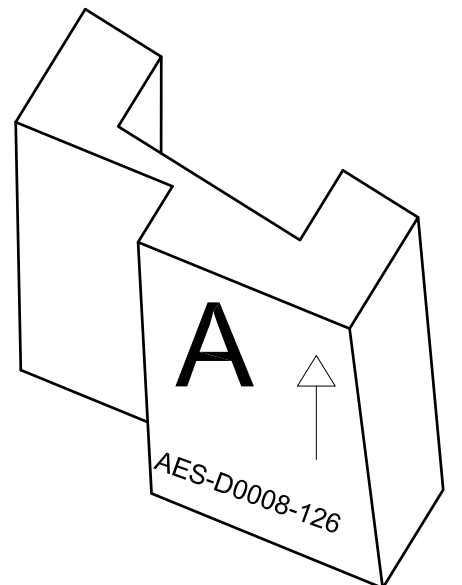

VIEW D3-65

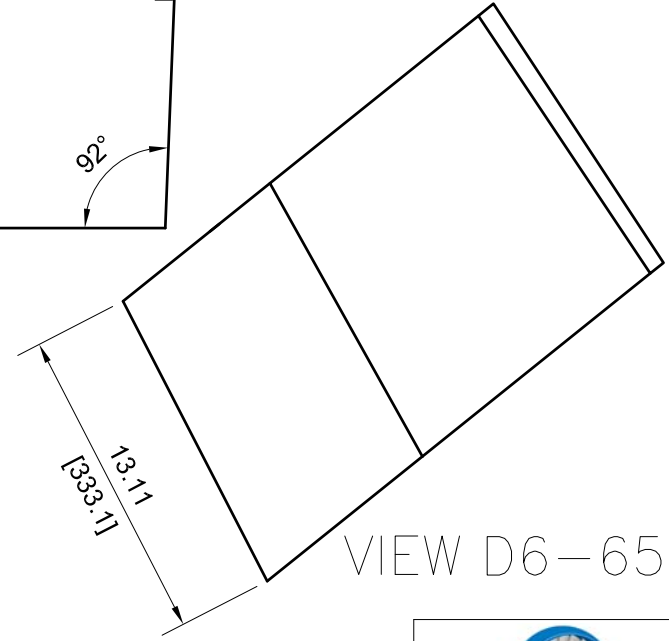
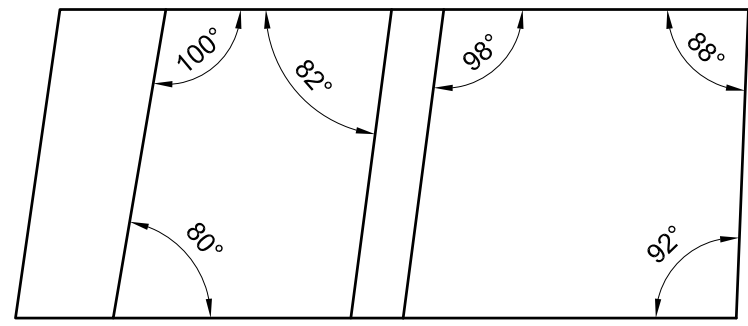

VIEW D6-65



DRAWING NUMBER					AES-D0008	
SIZE	SCALE	SHEET	OF	REVISION		
A3	NONE	65	190	B		

128

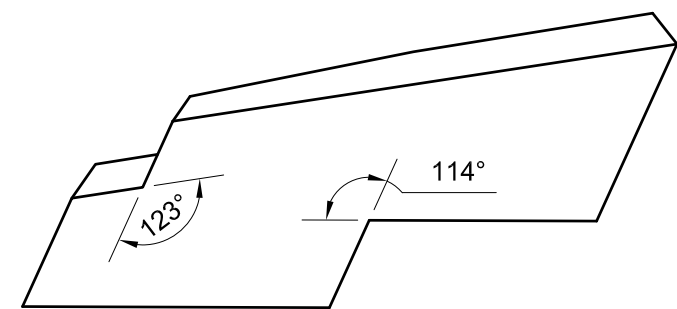
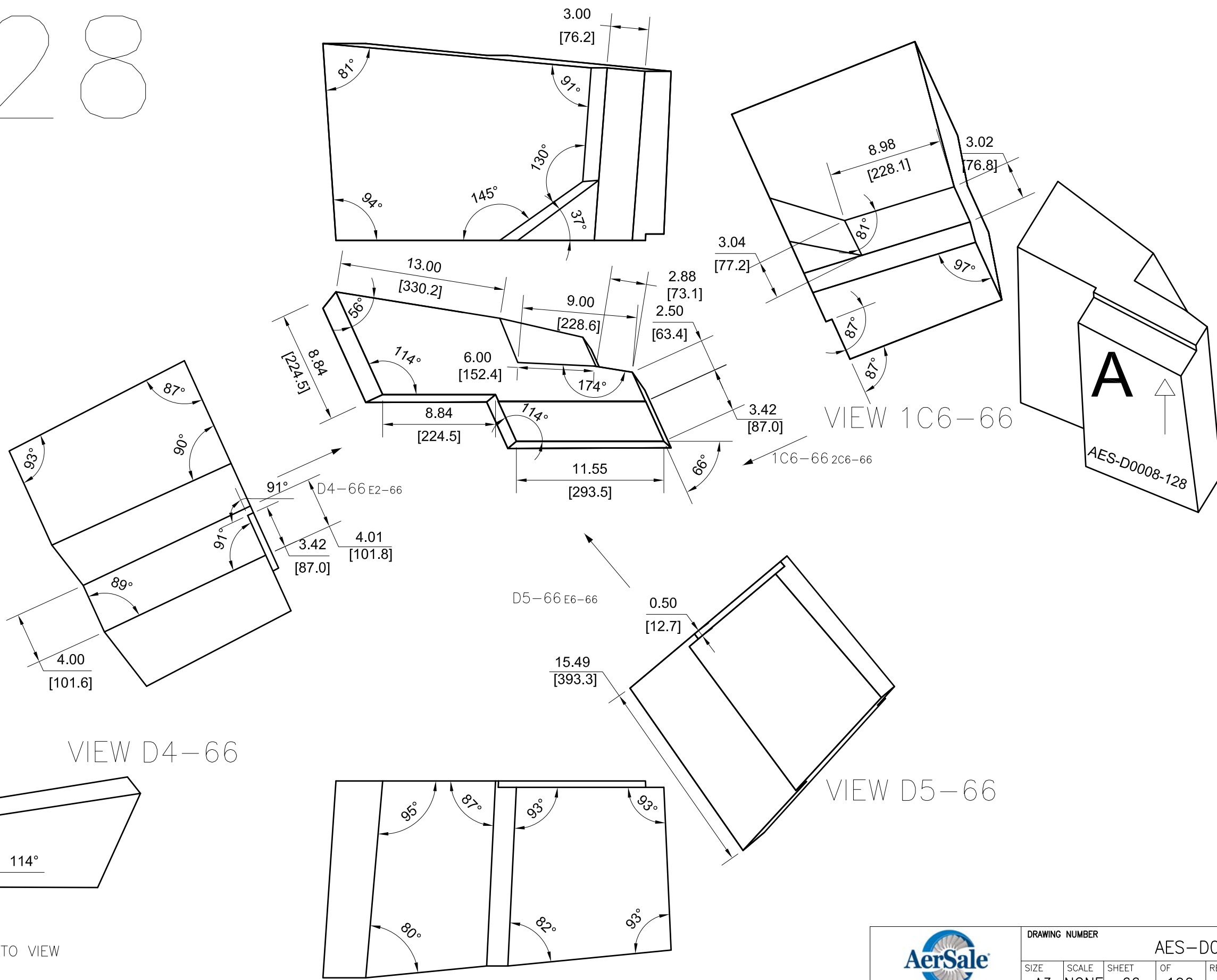

REAR VIEW RELATIVE TO VIEW C4-66

		DRAWING NUMBER			
		AES-D0008			
SIZE	SCALE	SHEET	OF	REVISION	
A3	NONE	66	190	B	

— 130

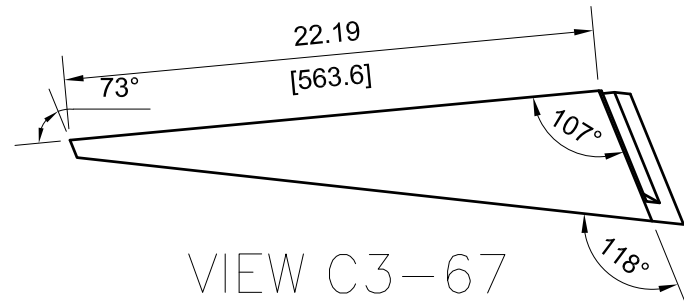

VIEW C3-67

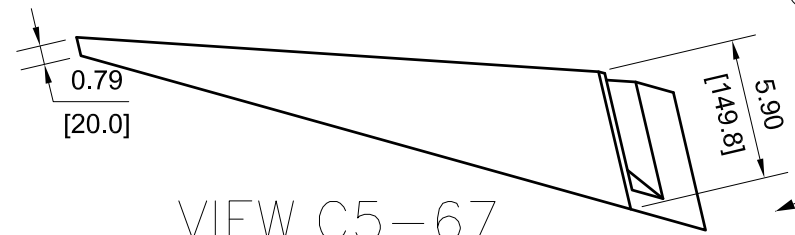

VIEW C5-67

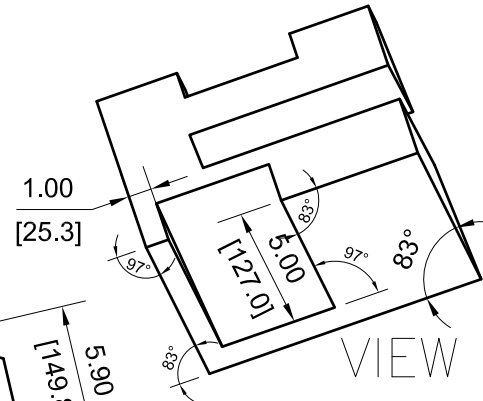

VIEW 1C6-67

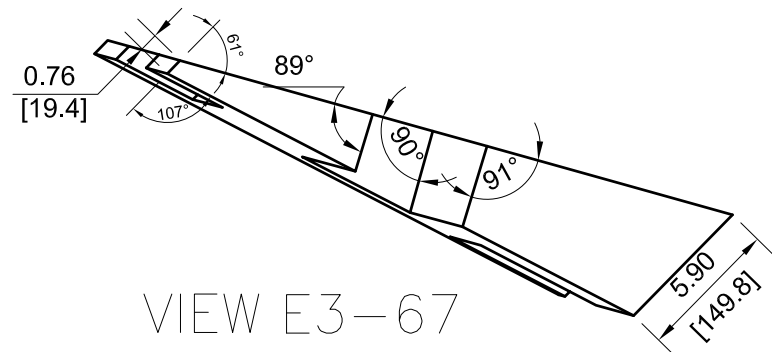
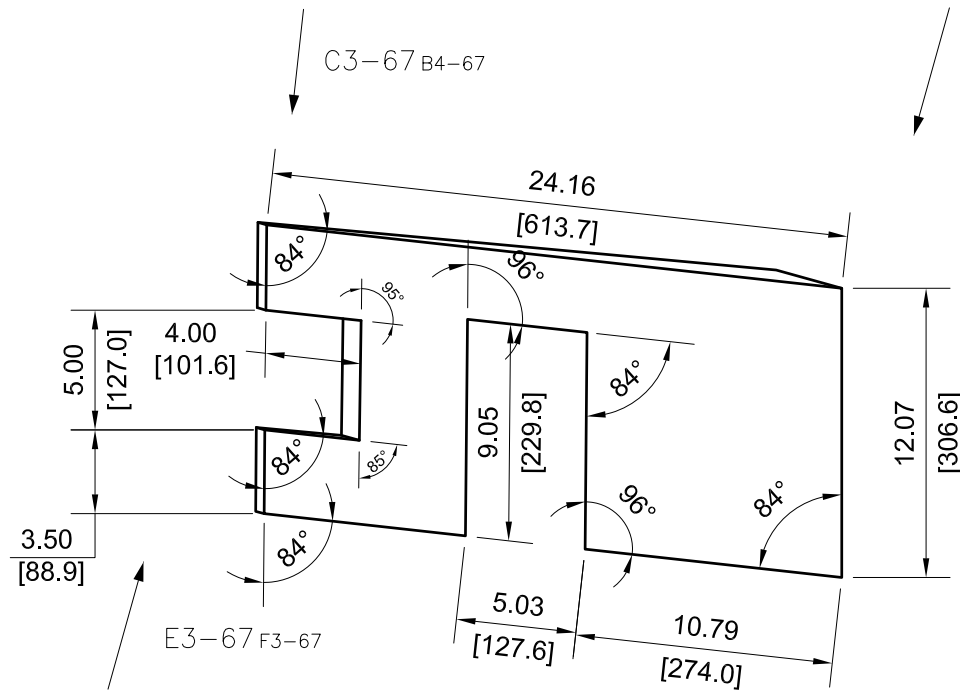
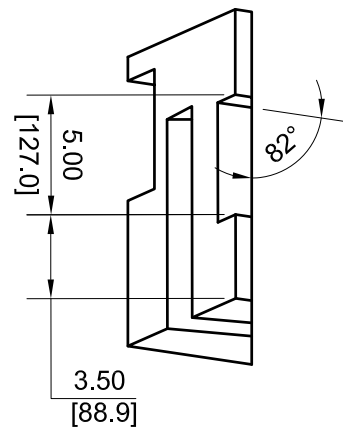
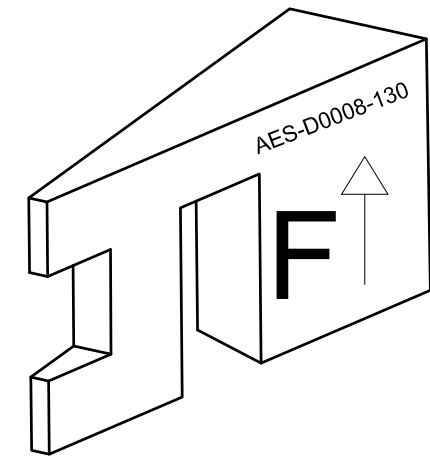

VIEW E3-67

		DRAWING NUMBER			
		AES-D0008			
SIZE	SCALE	SHEET	OF	REVISION	
A3	NONE	67	190	B	

- 132

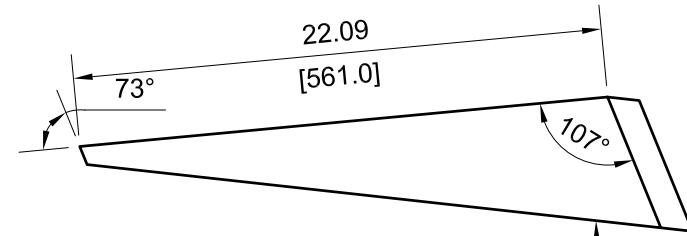

VIEW C3-68

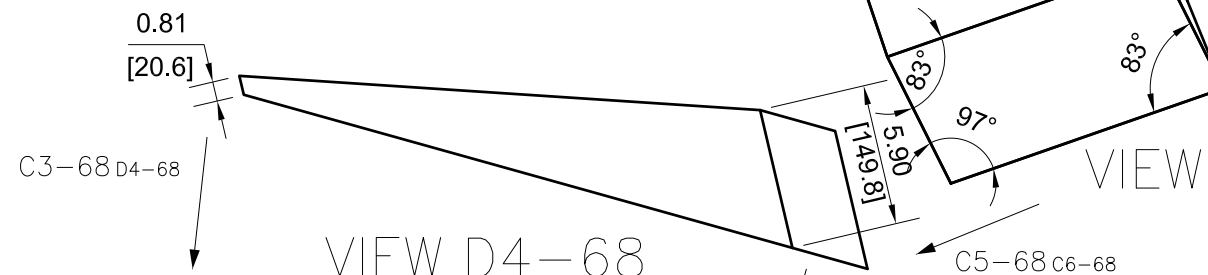
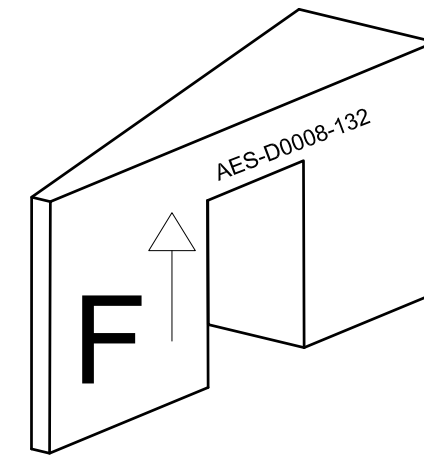

VIEW D4-68

VIEW C5-68

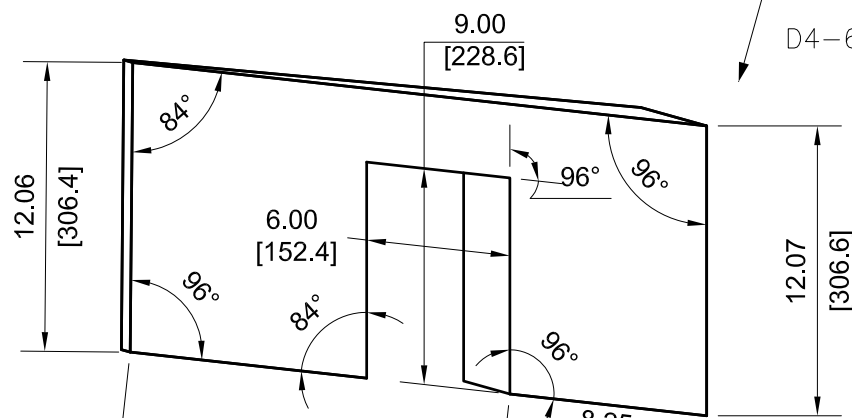

VIEW E4-68

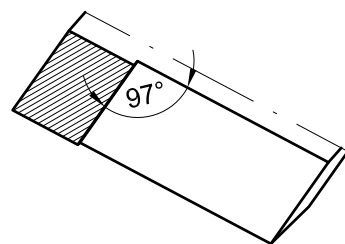

SECTION VIEW D3-68

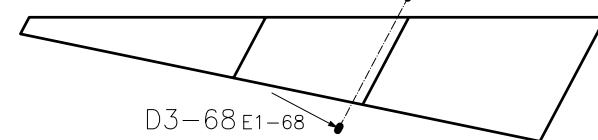
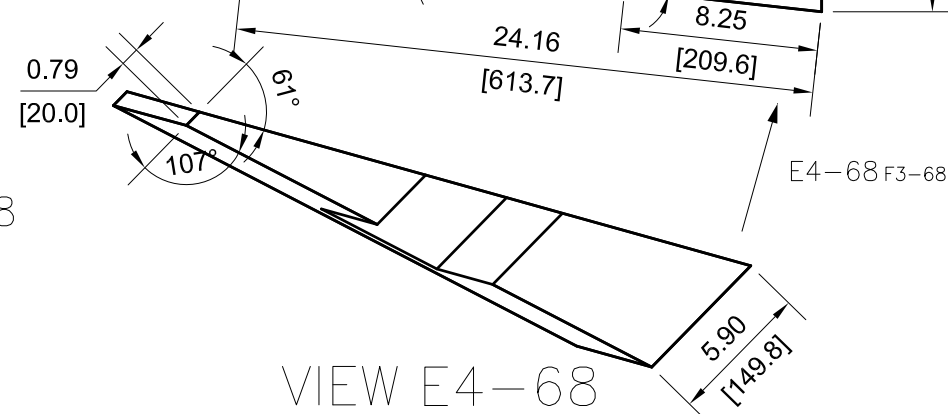

D3-68 E1-68



DRAWING NUMBER					AES-D0008				
SIZE	SCALE	SHEET	OF	REVISION					
A3	NONE	68	190	B					

134

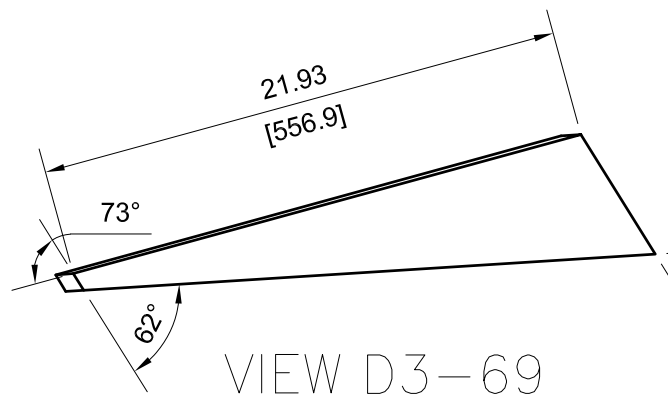

VIEW D3-69

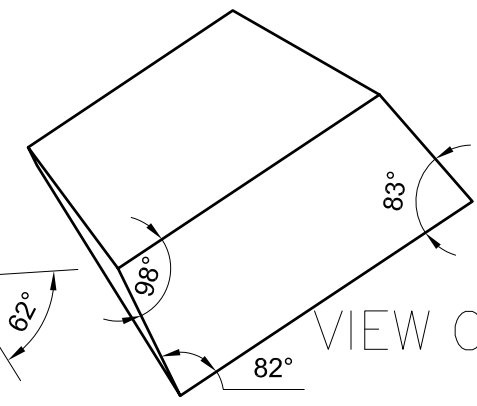

VIEW C6-69

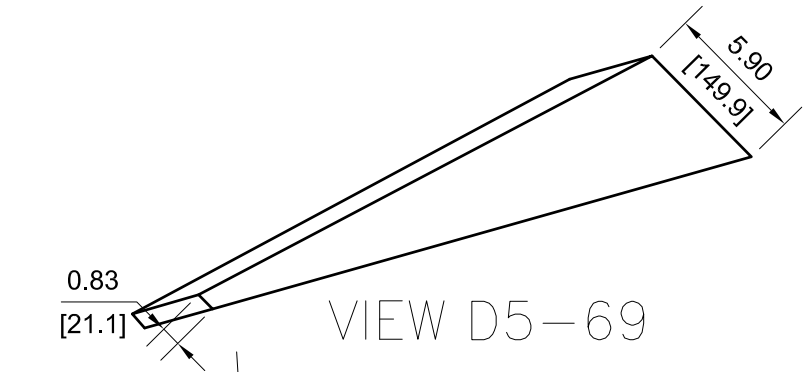
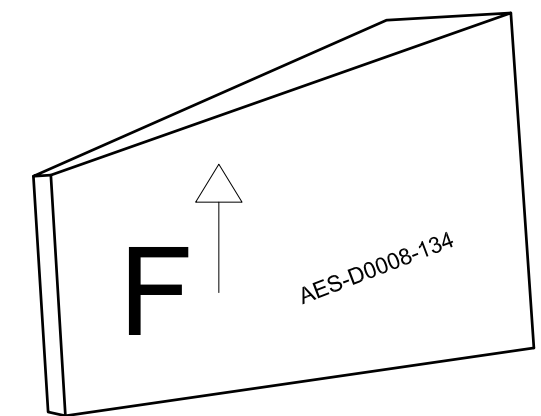

VIEW D5-69

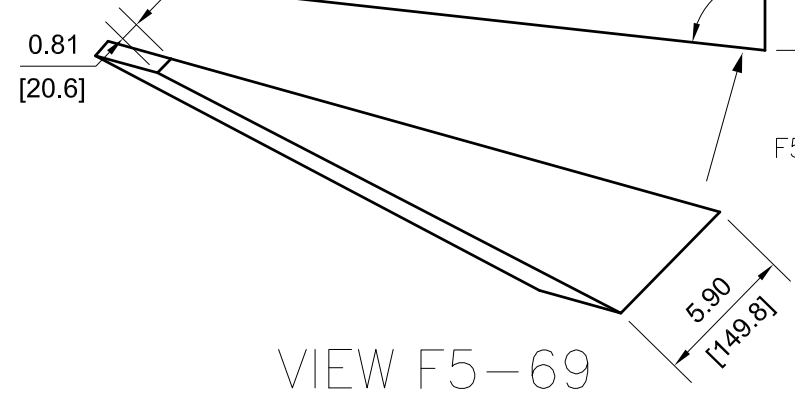
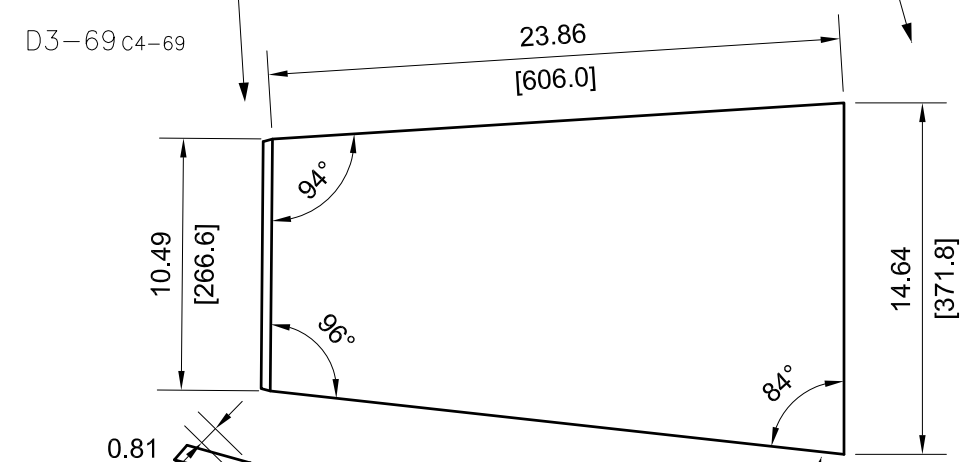

VIEW F5-69

C6-69 B6-69

D5-69 D4-69

F5-69 F4-69



DRAWING NUMBER					AES-D0008	
SIZE	SCALE	SHEET	OF	REVISION		
A3	NONE	69	190	B		

136

VIEW C3-70

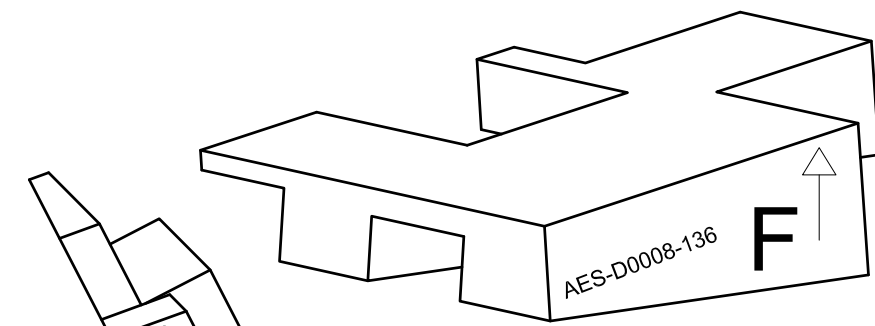
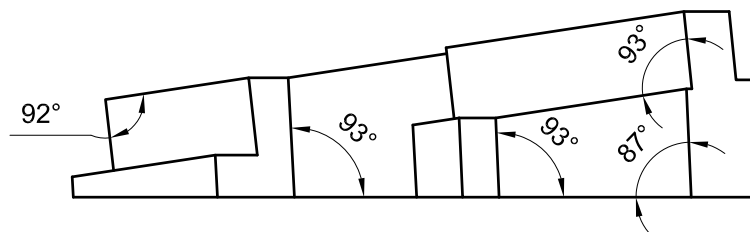
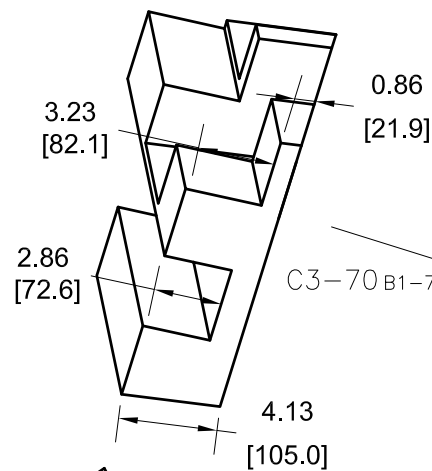

VIEW C6-70

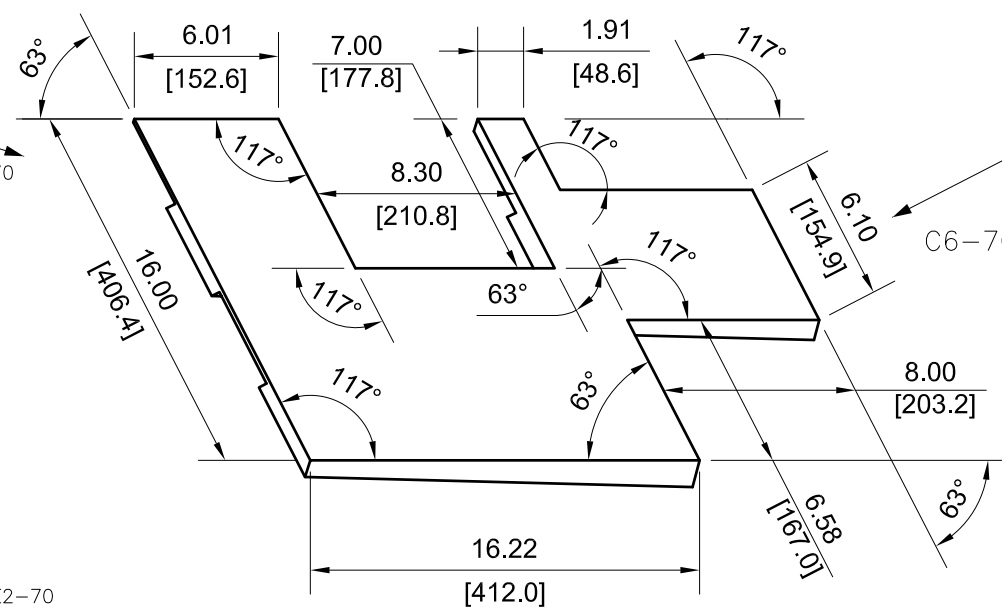
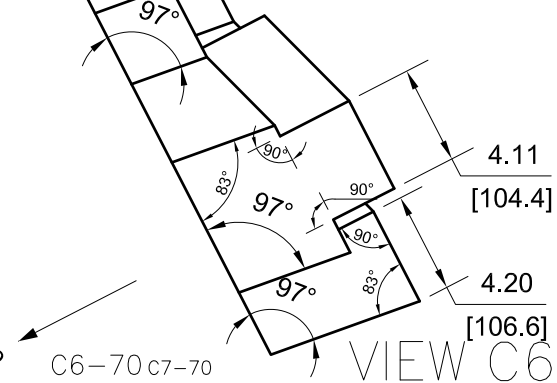

VIEW D3-70

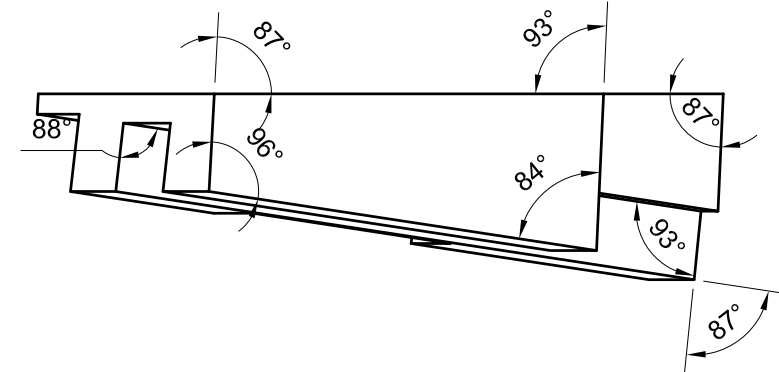
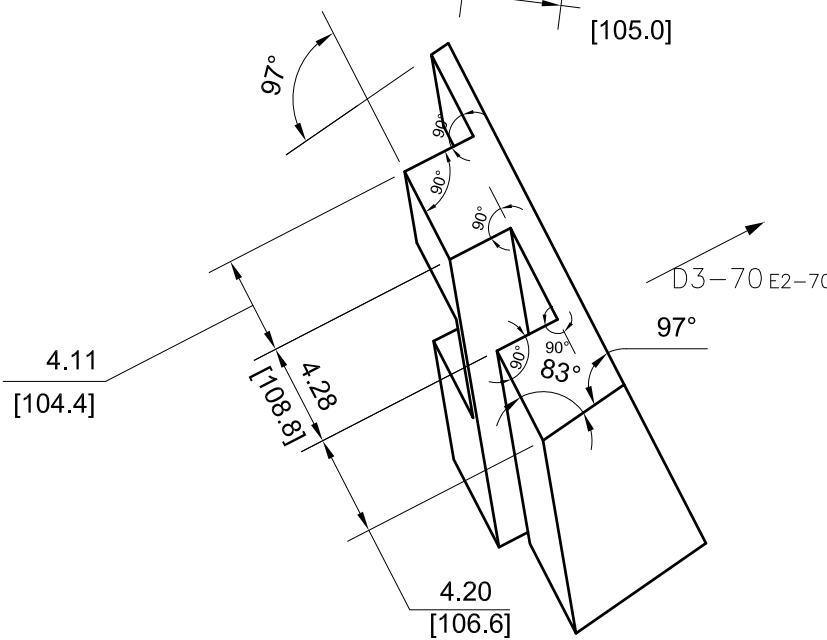

DRAWING NUMBER					AES-D0008				
SIZE	SCALE	SHEET	OF	REVISION					
A3	NONE	70	190	B					

138

VIEW C3-71

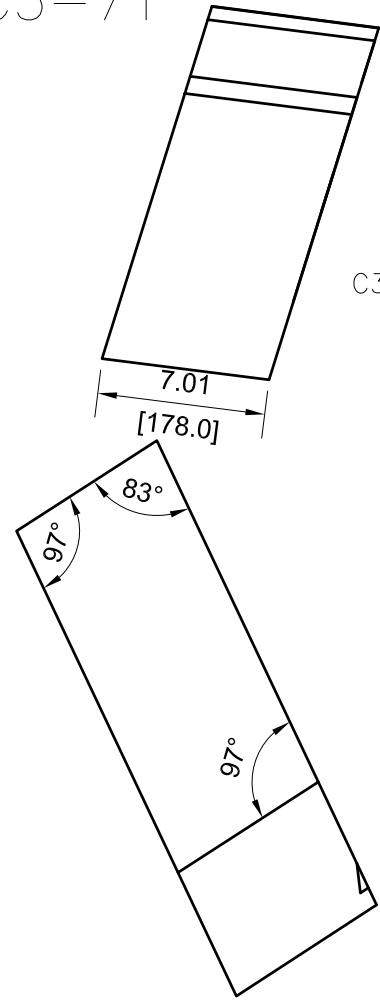

VIEW D4-71

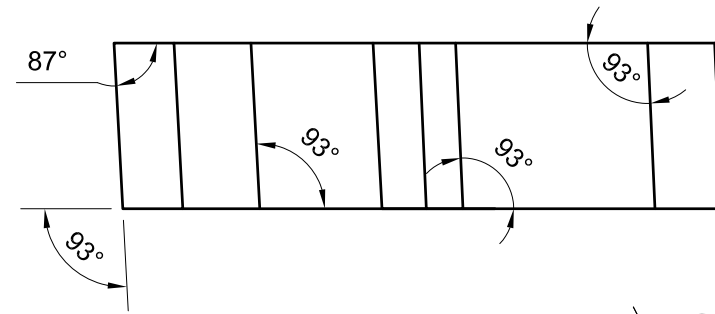

C3-71B2-71

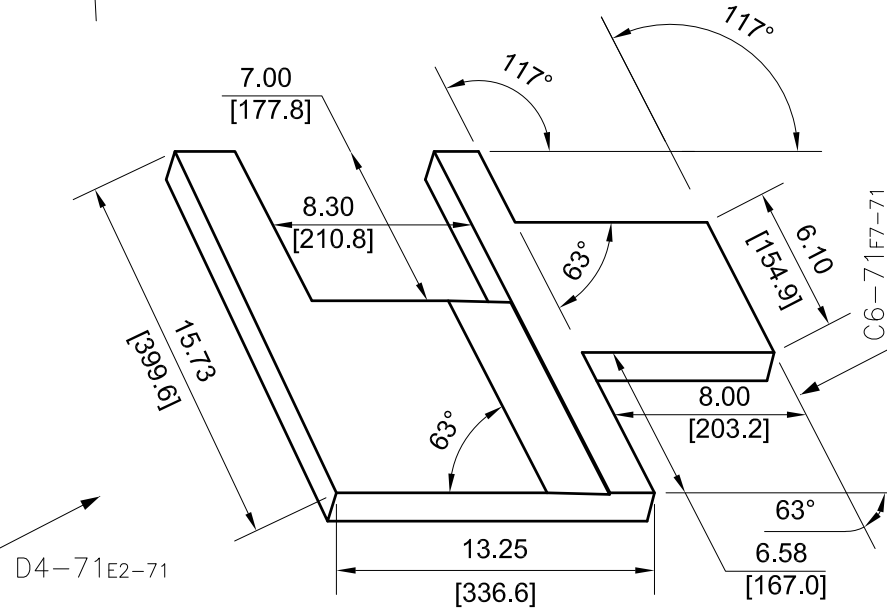

D4-71E2-71

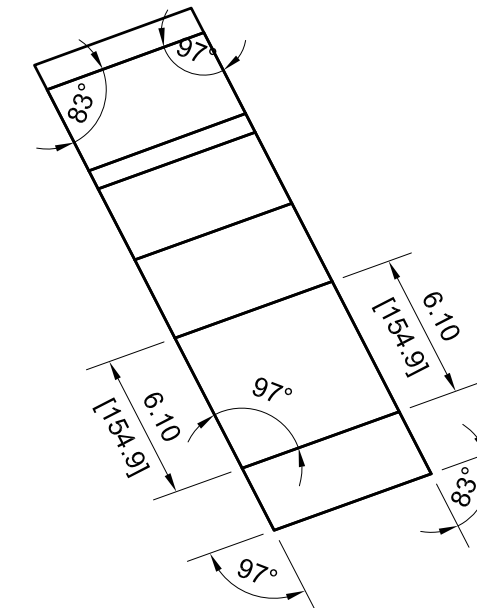
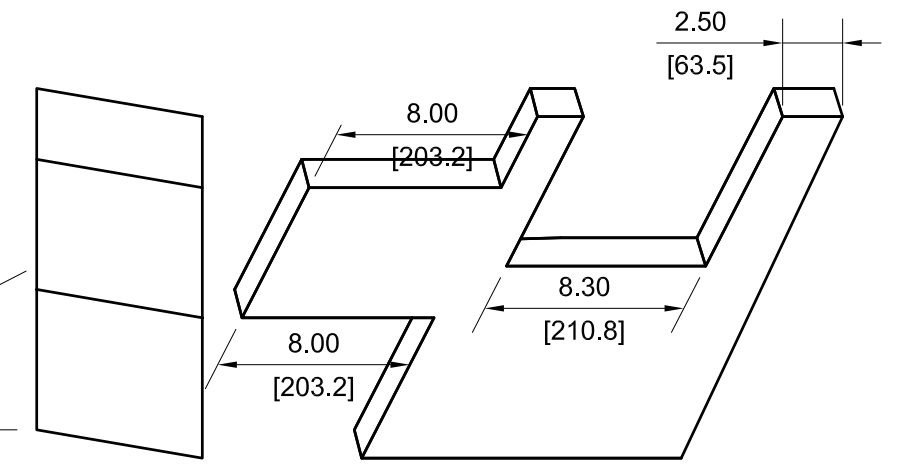
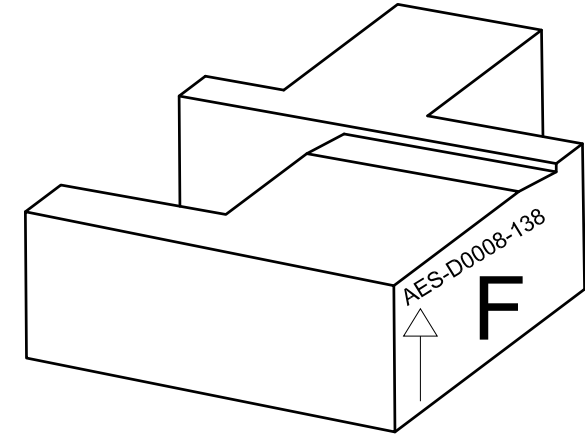

VIEW C6-71



DRAWING NUMBER					AES-D0008				
SIZE	SCALE	SHEET	OF	REVISION					
A3	NONE	71	190	B					

140

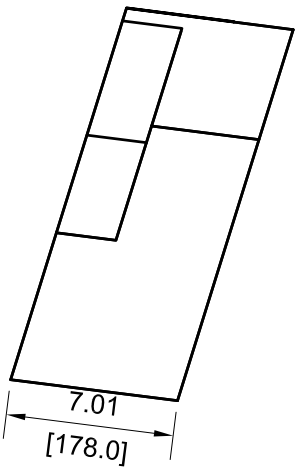

VIEW C2-72

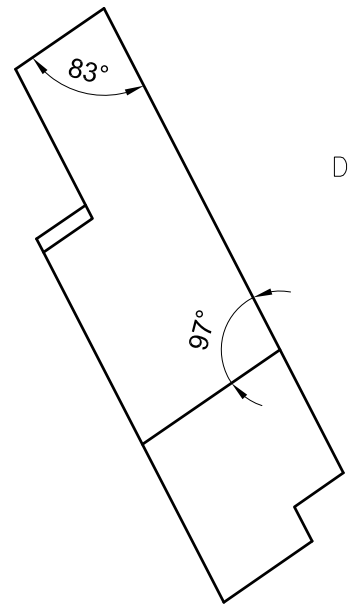

VIEW D2-72

C2-72 C1-72

D2-72 E1-72

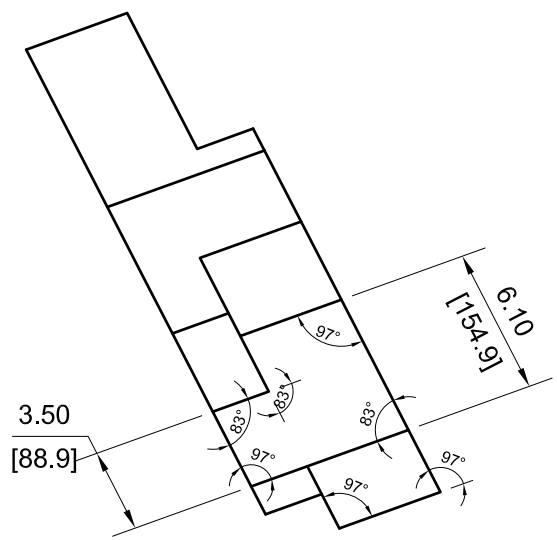
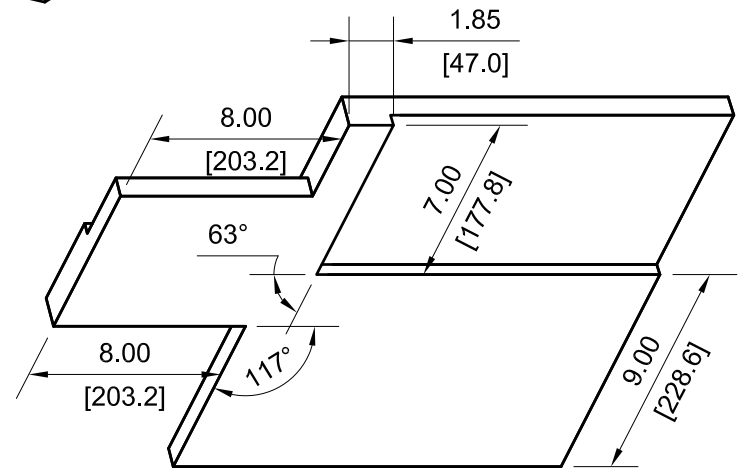
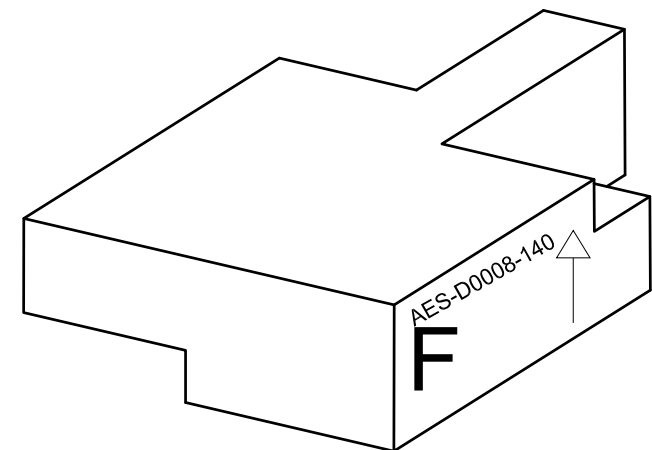
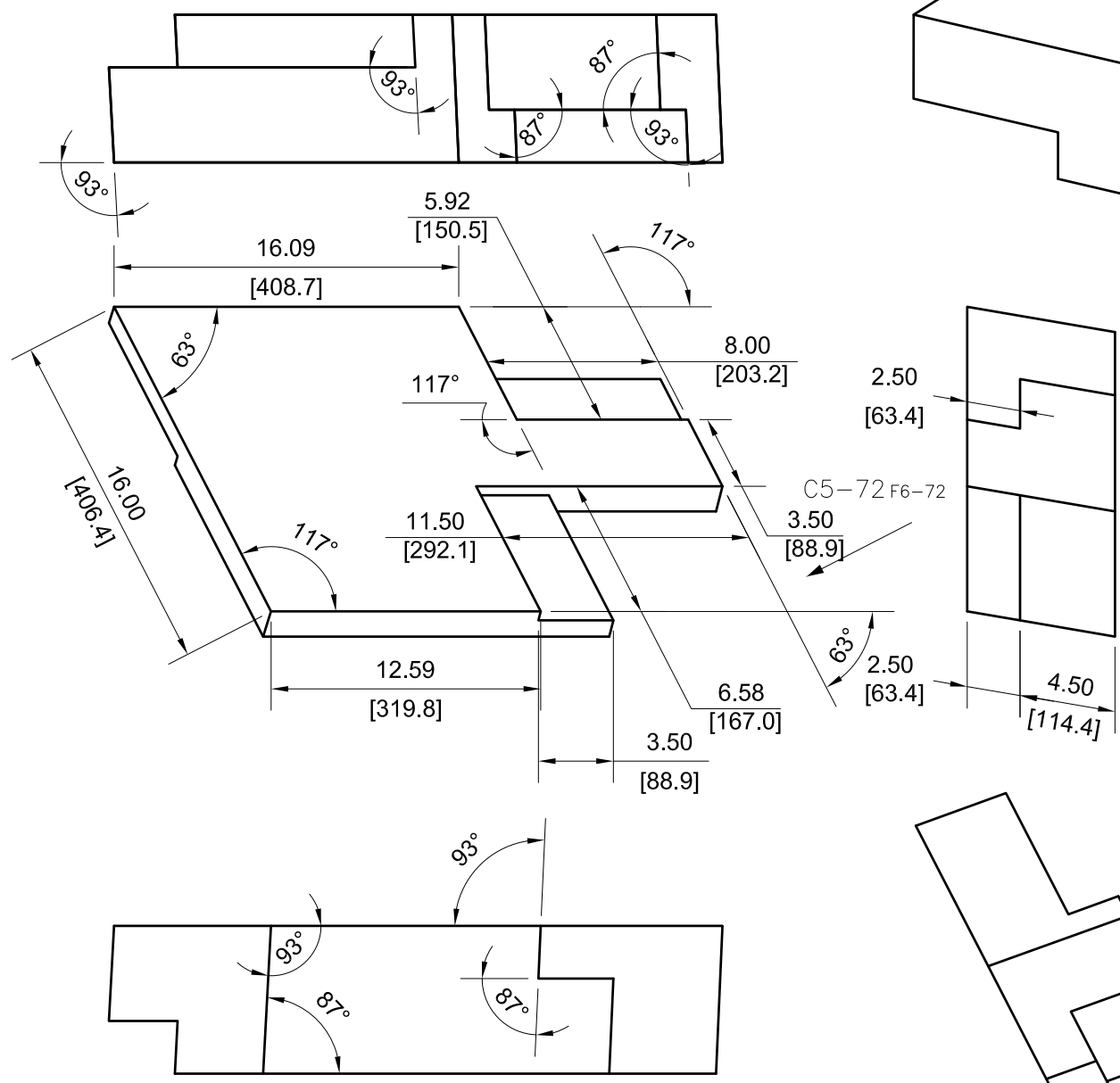

VIEW C5-72



DRAWING NUMBER				
AES-D0008				
SIZE	SCALE	SHEET	OF	REVISION
A3	NONE	72	190	B

142

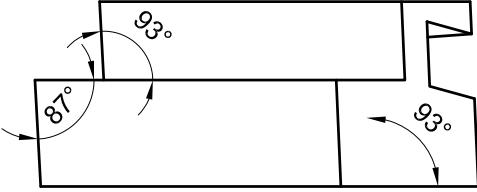
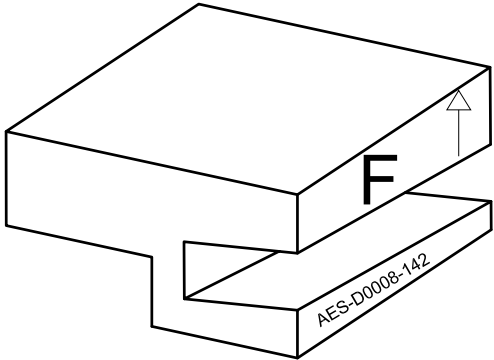

VIEW C2-73

C2-73 c1-73

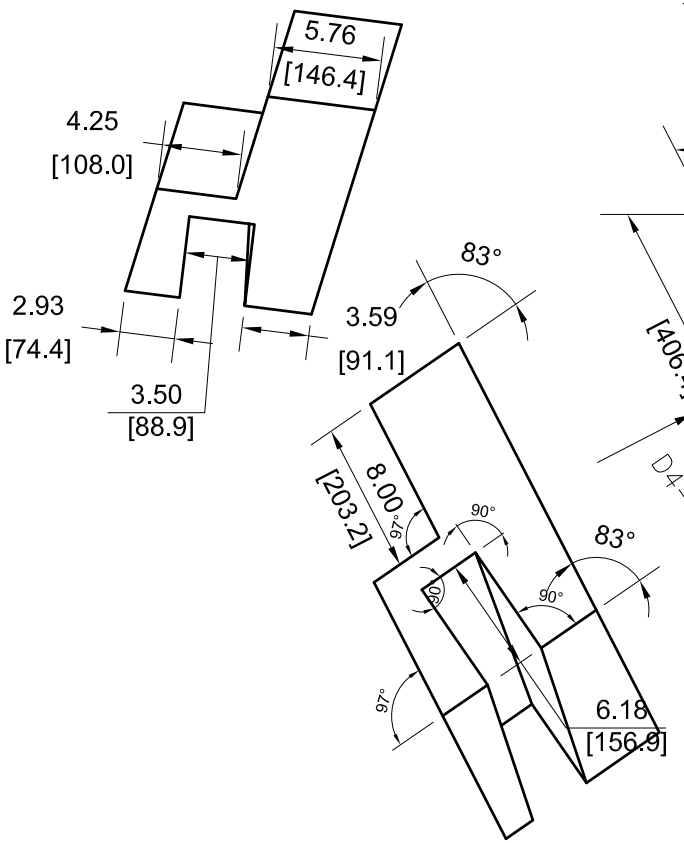

VIEW D4-73

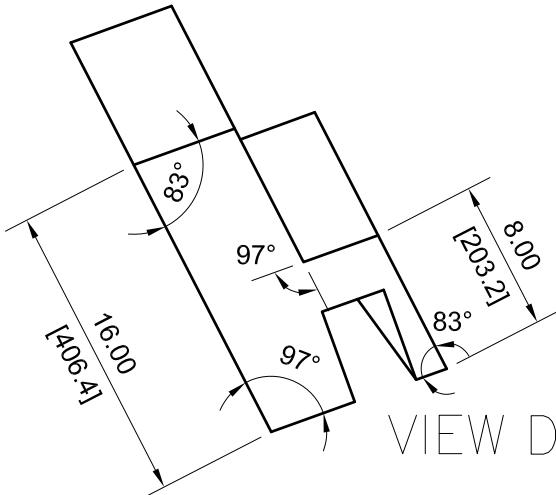
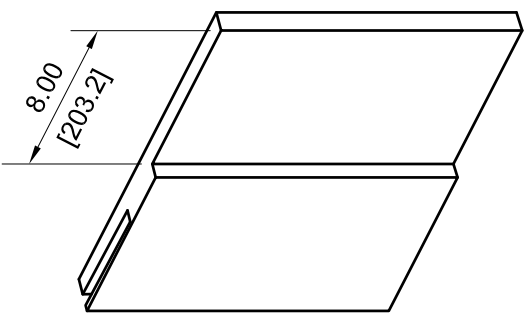
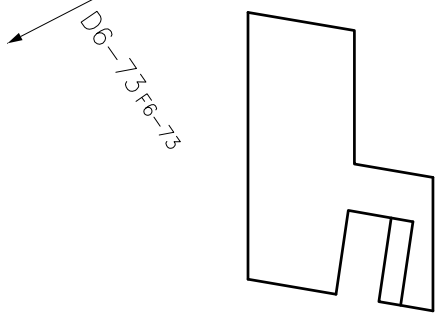
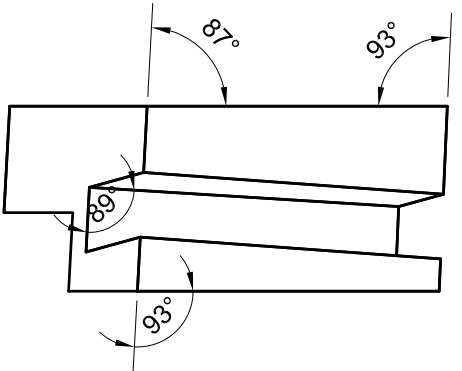
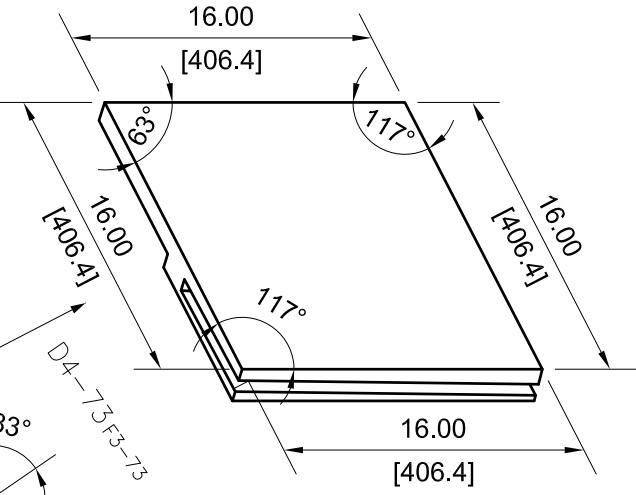

VIEW D6-73



DRAWING NUMBER				
AES-D0008				
SIZE	SCALE	SHEET	OF	REVISION
A3	NONE	73	190	B

1 4 4

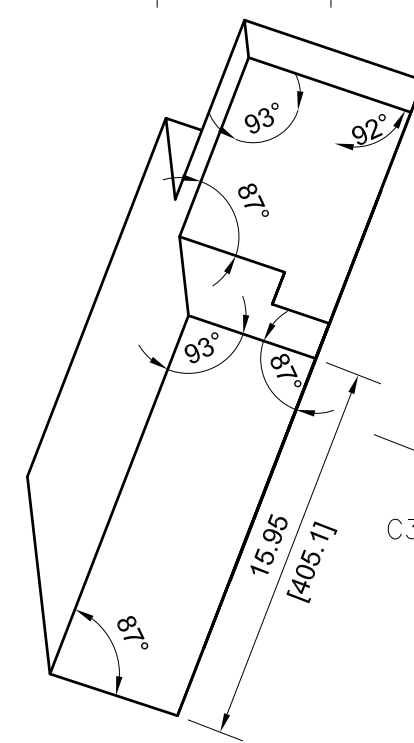

VIEW C3-74

VIEW D4-74

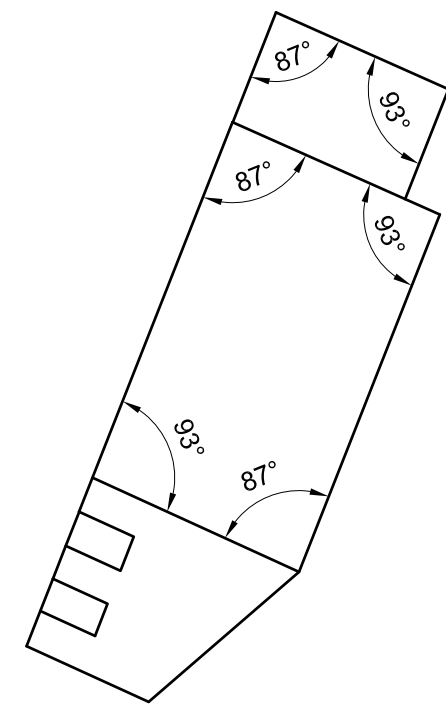
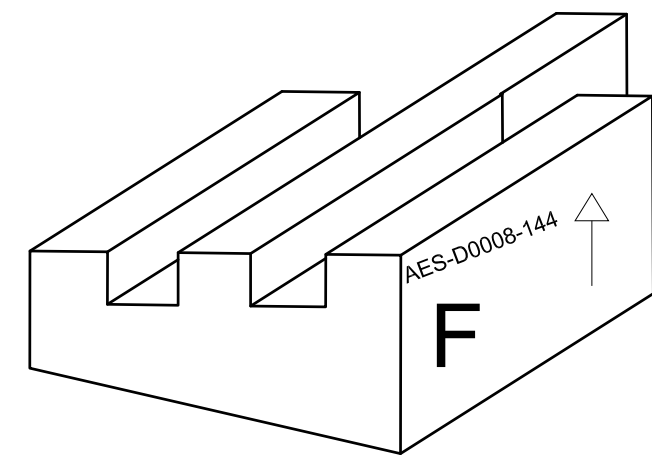
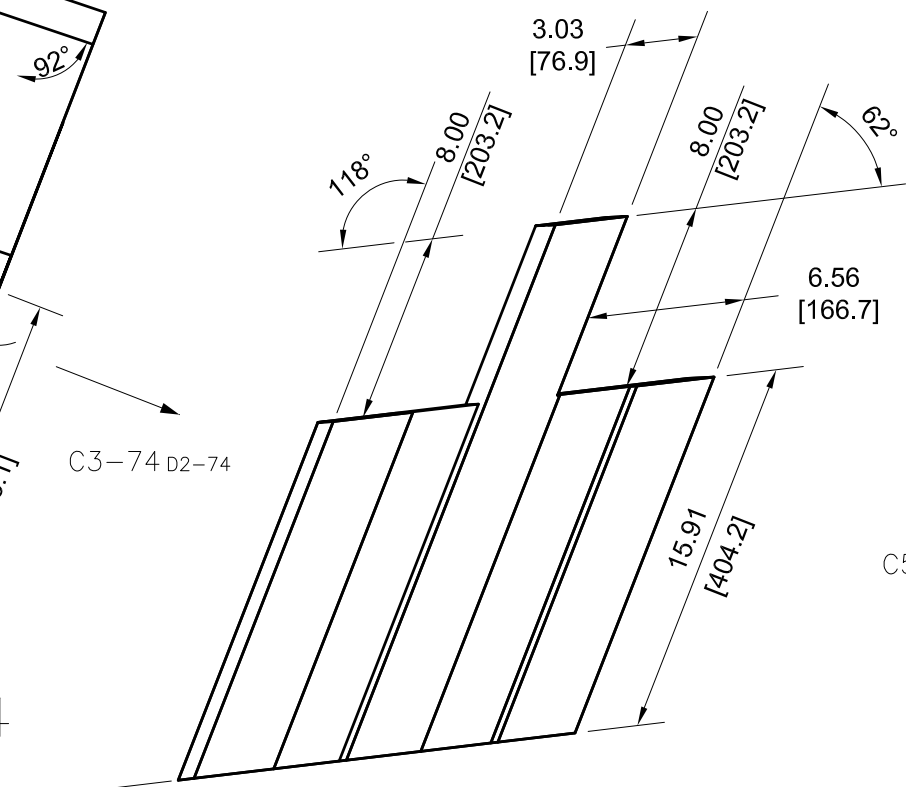

VIEW C5-74

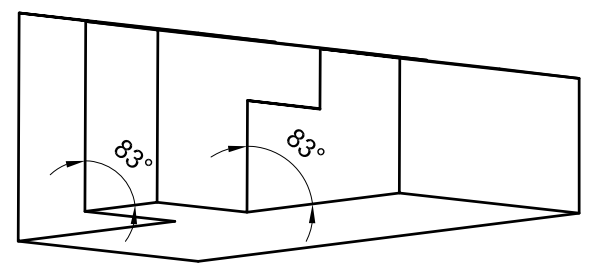

REAR VIEW RELATIVE TO VIEW E3-74

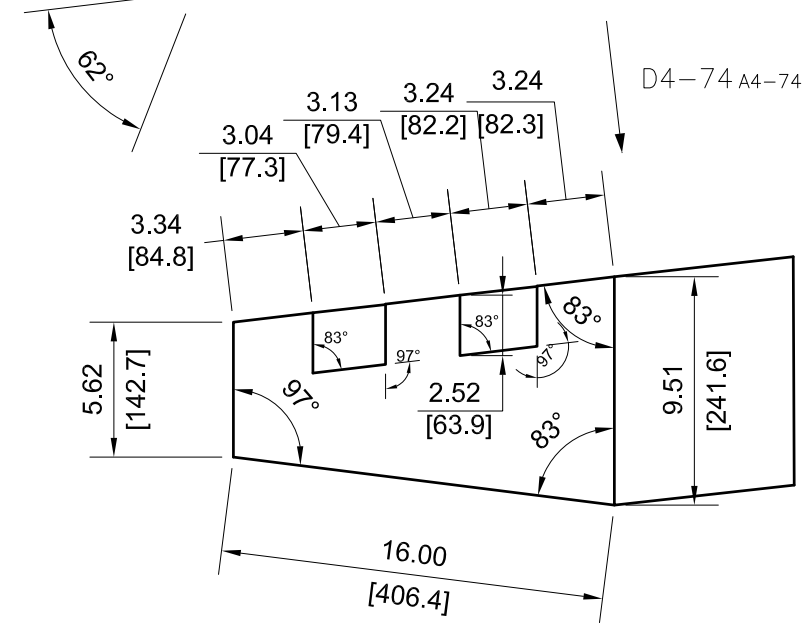

D4-74 A4-74

		DRAWING NUMBER			
		AES-D0008			
SIZE	SCALE	SHEET	OF	REVISION	
A3	NONE	74	190	B	

146

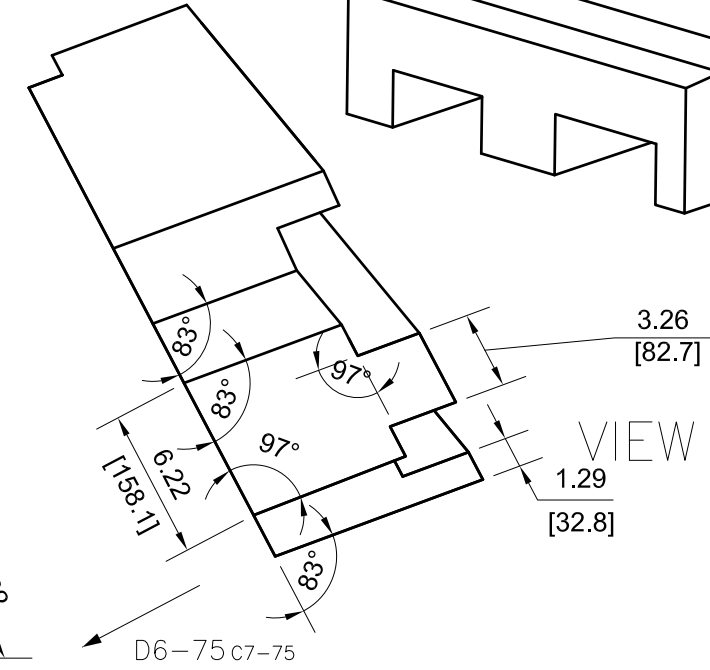
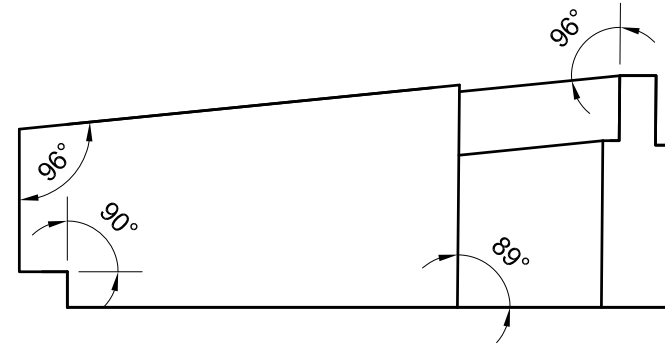
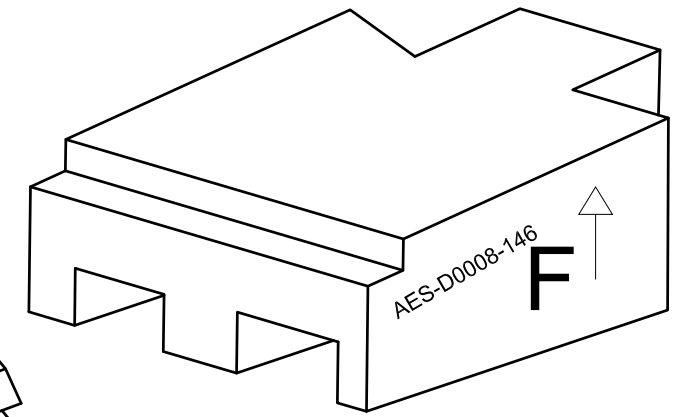

VIEW D6-75

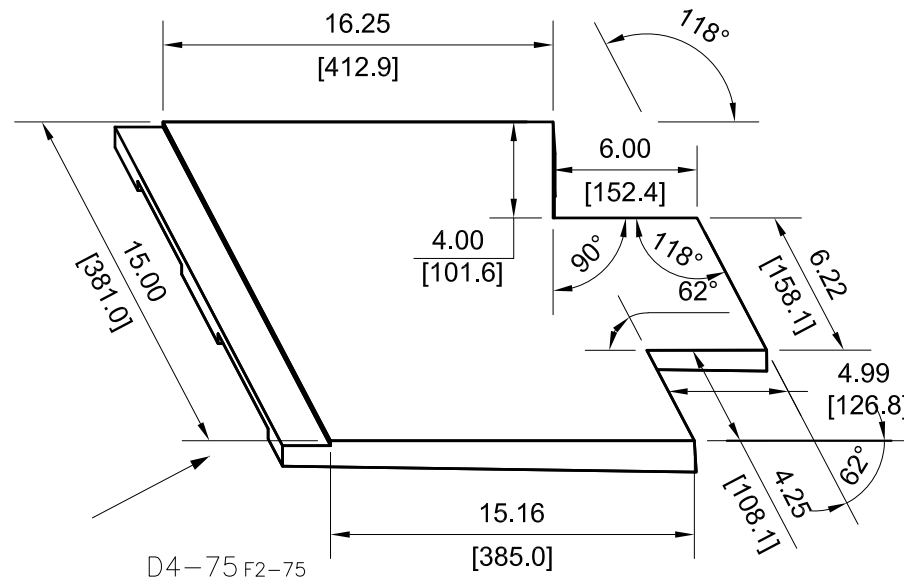

D4-75 F2-75

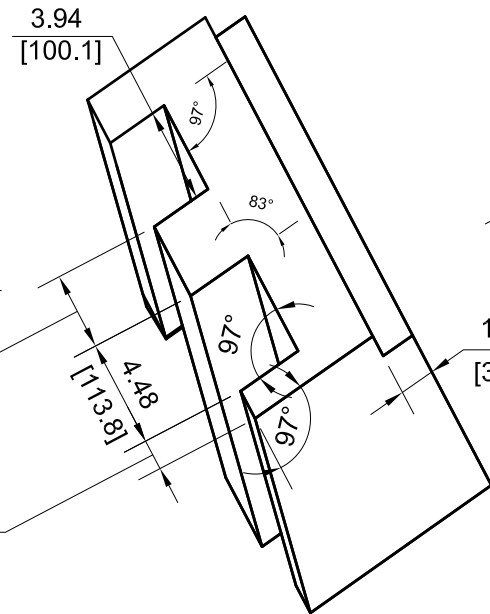
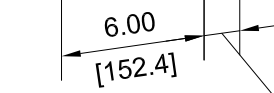
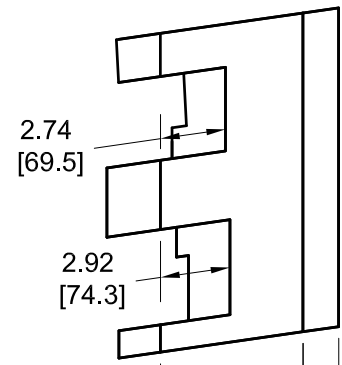

VIEW D4-75

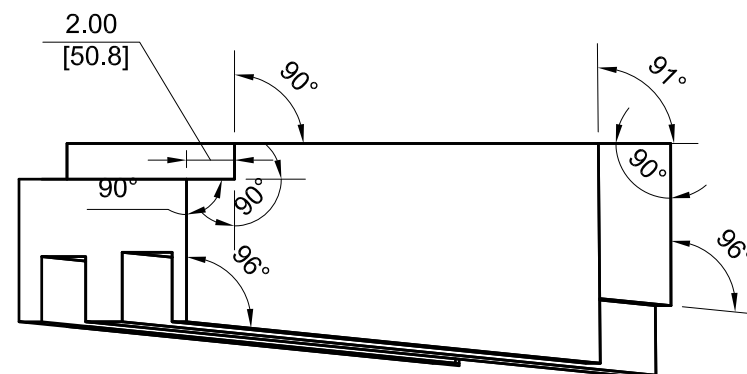

DRAWING NUMBER				
AES-D0008				
SIZE	SCALE	SHEET	OF	REVISION
A3	NONE	75	190	B

148

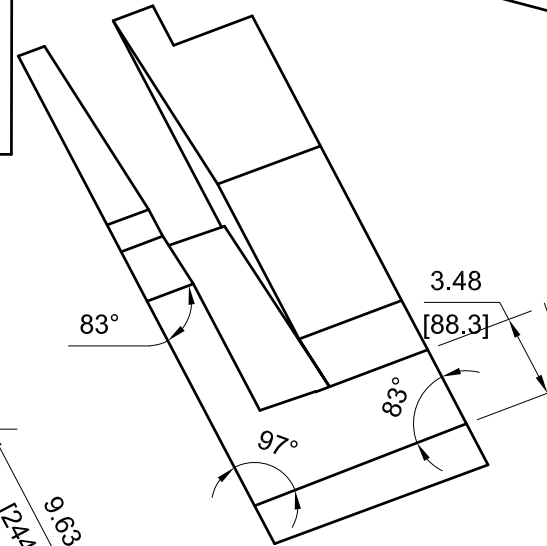
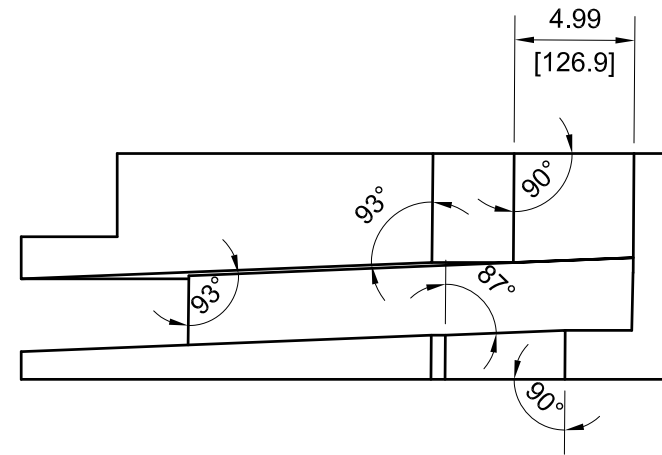
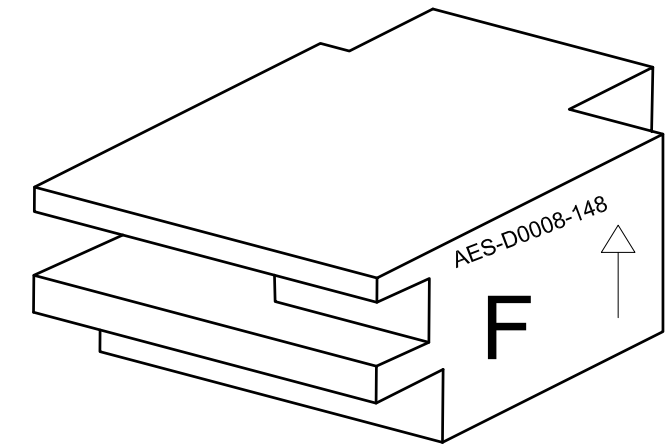

VIEW D6-76

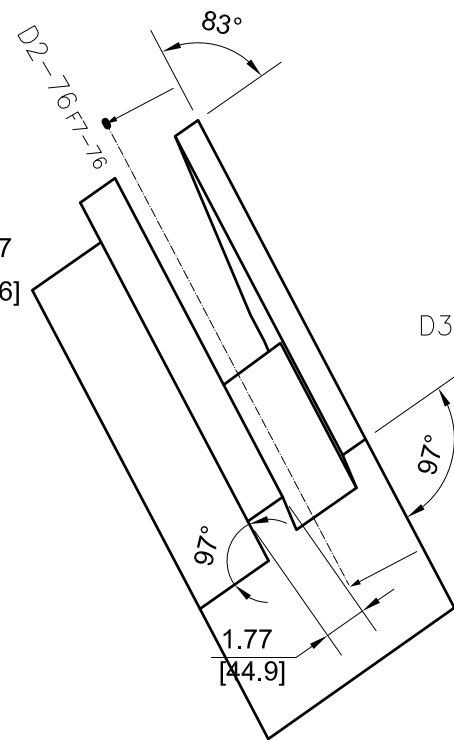
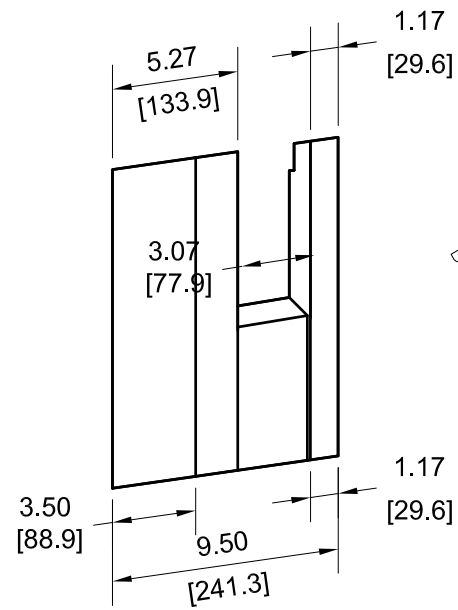
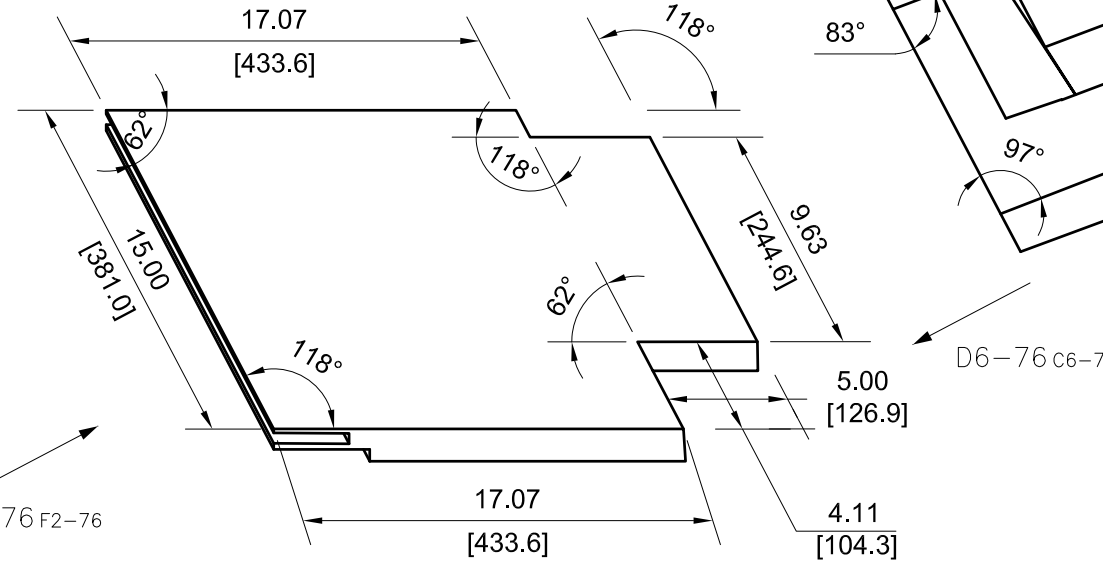

VIEW D3-76

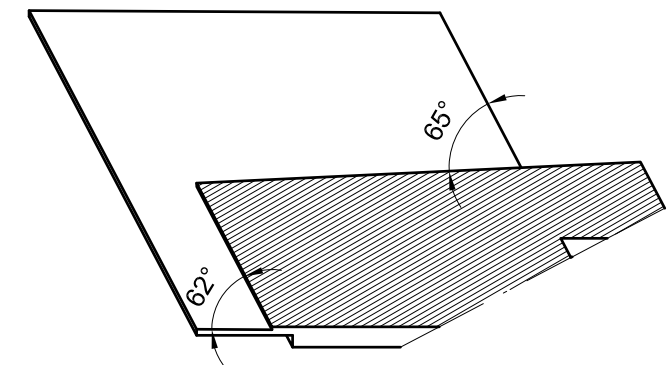
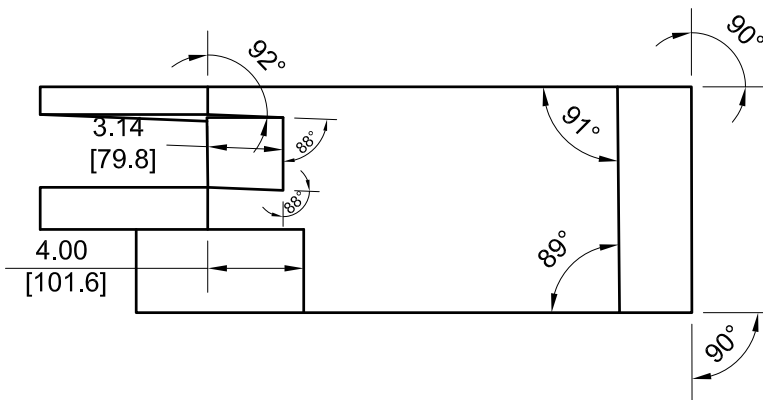

SECTION VIEW D2-76

	DRAWING NUMBER				
	AES-D0008				
SIZE	SCALE	SHEET	OF	REVISION	
A3	NONE	76	190	B	

150

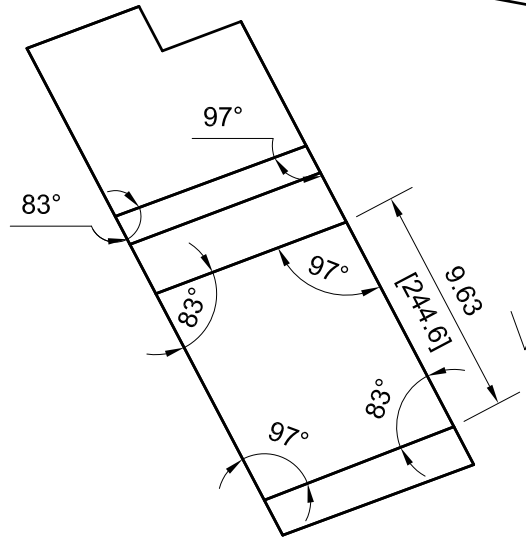
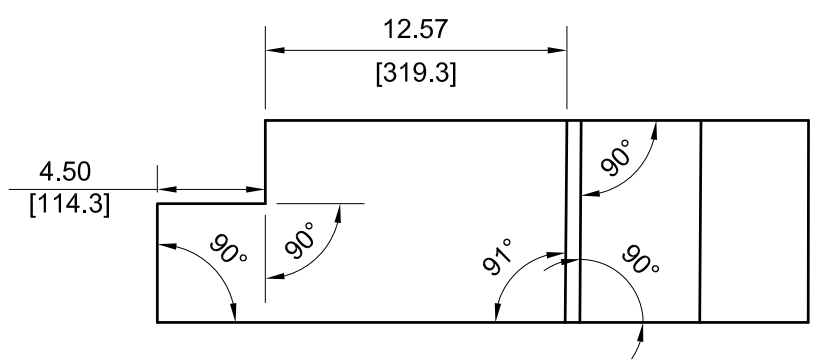
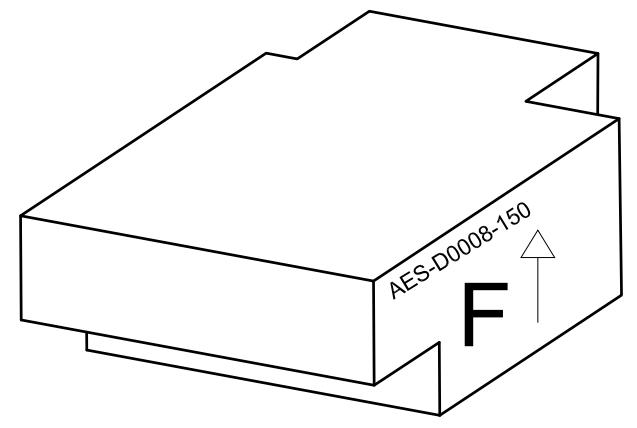

VIEW D6-77

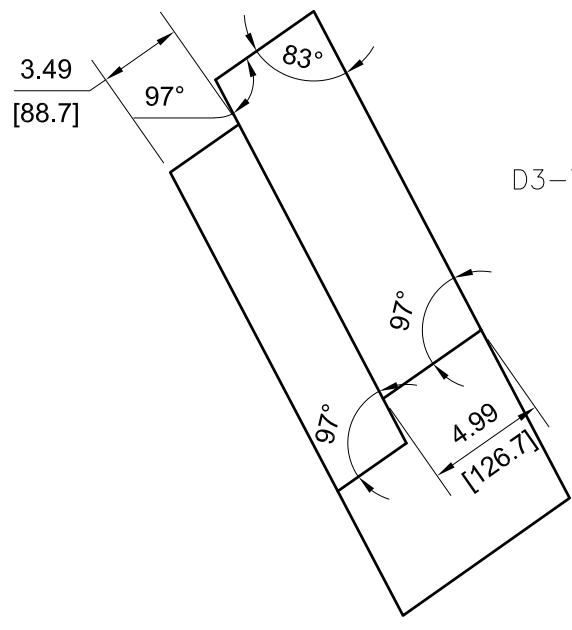
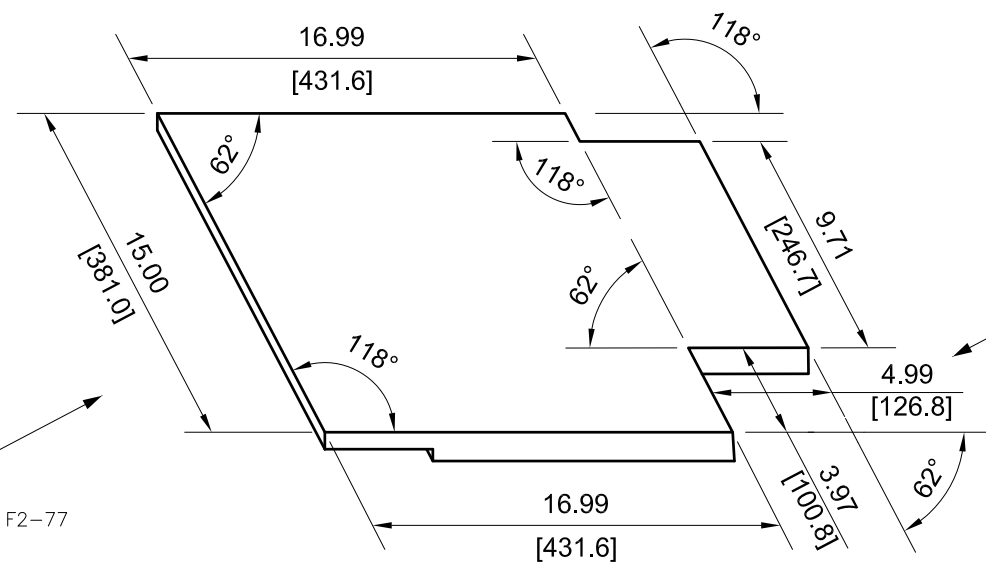

VIEW D3-77

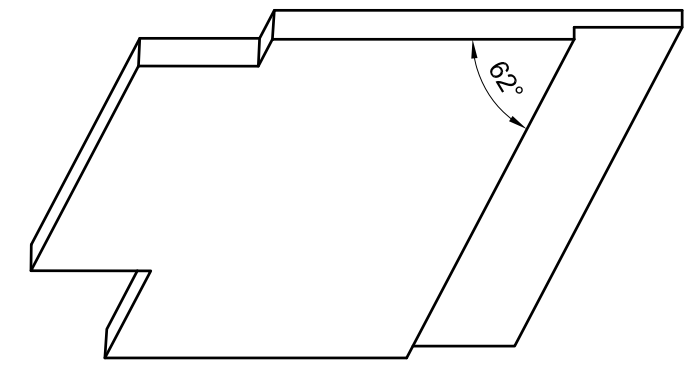
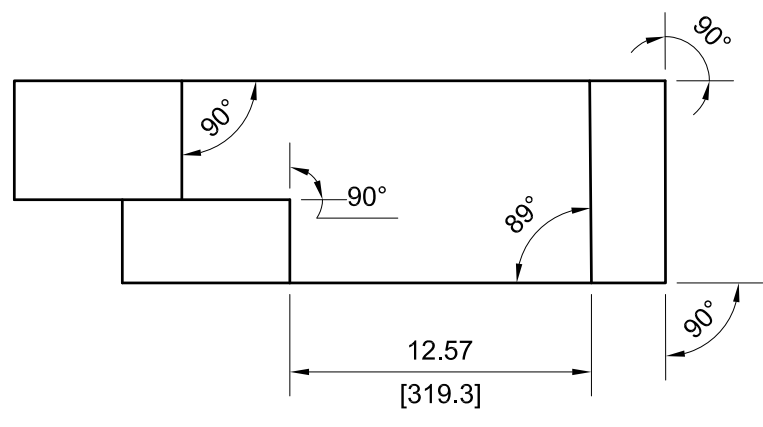

REAR VIEW RELATIVE TO VIEW D4-77



DRAWING NUMBER					AES-D0008				
SIZE	SCALE	SHEET	OF	REVISION					
A3	NONE	77	190	B					

152

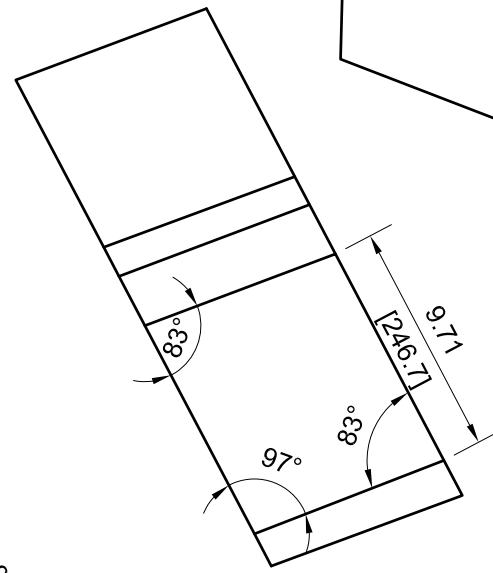
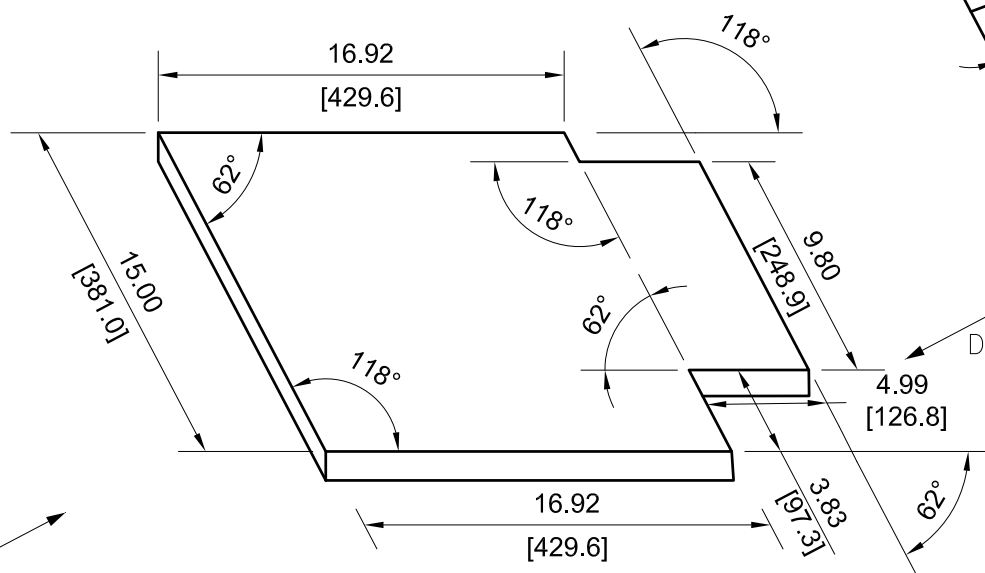
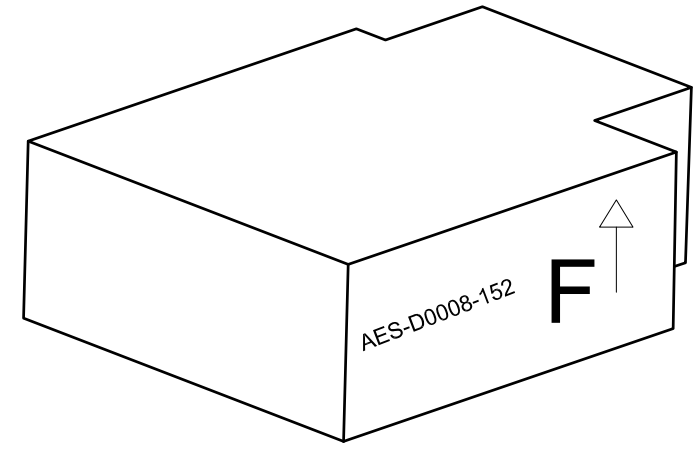
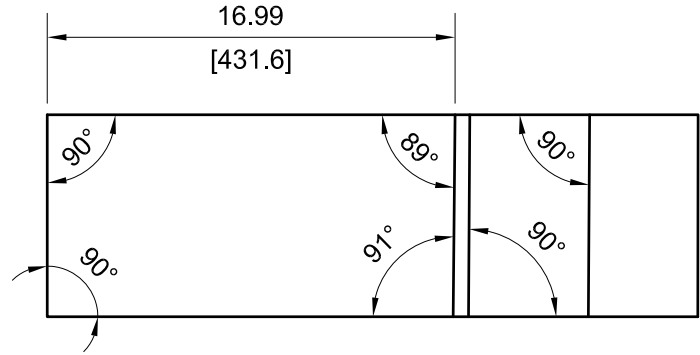

VIEW D5-78

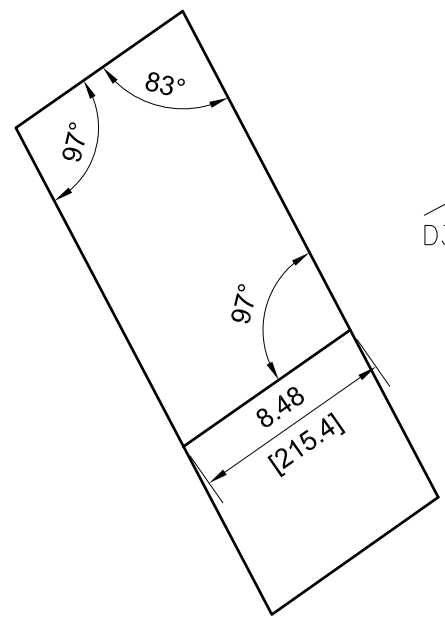

D3-78 F2-78

VIEW D3-78

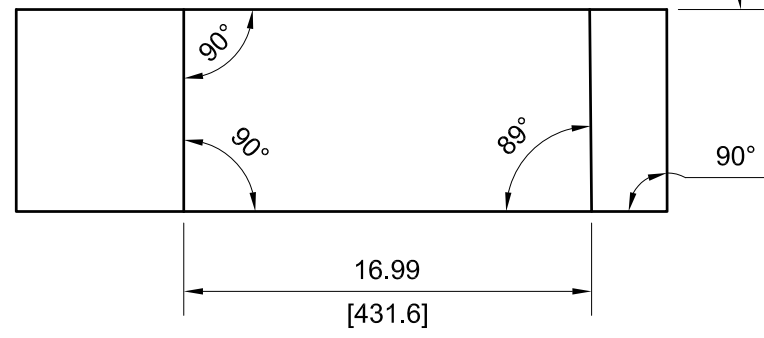

DRAWING NUMBER					AES-D0008				
SIZE	SCALE	SHEET	OF	REVISION					
A3	NONE	78	190	B					

154

VIEW D1-79

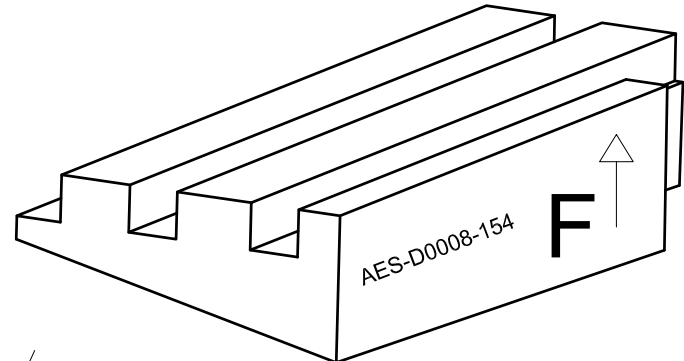
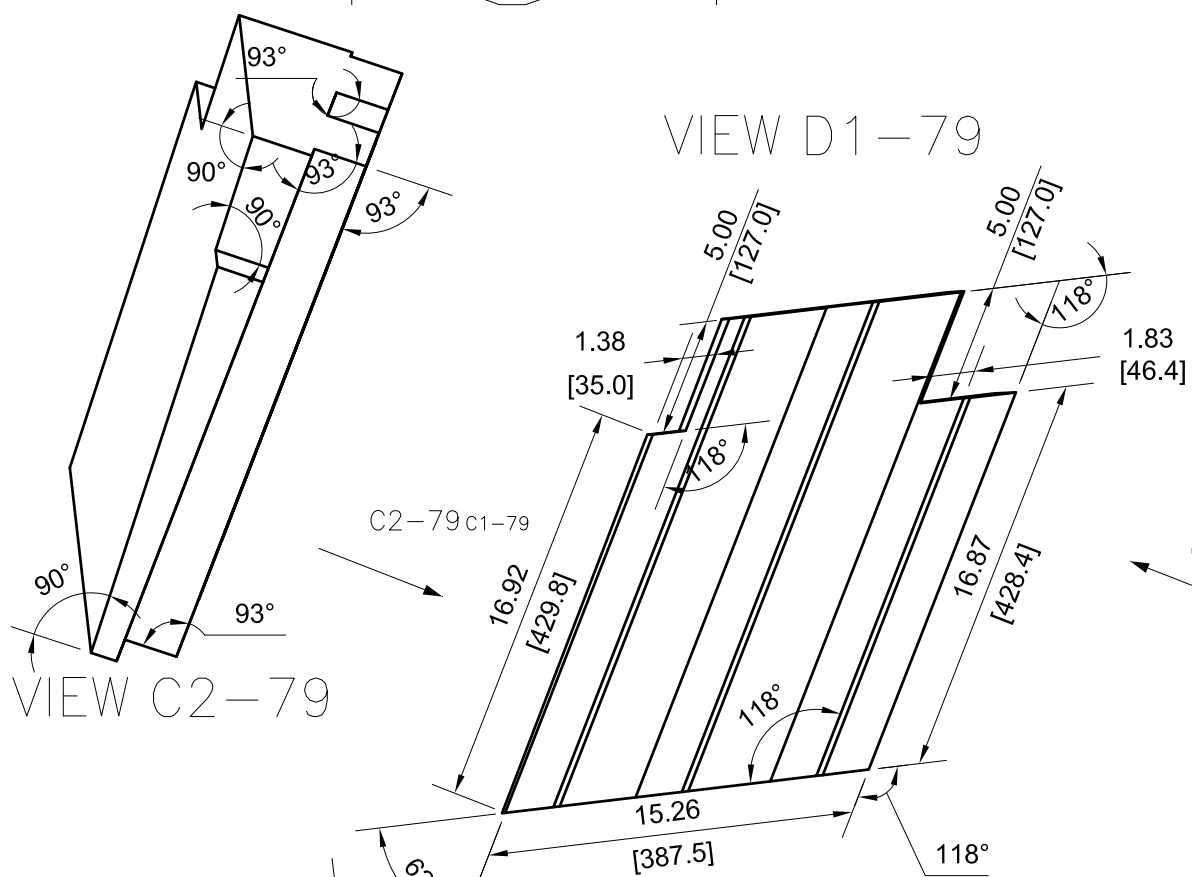

VIEW C2-79

C4-79 E4-79

VIEW C4-79

D1-79 B2-79

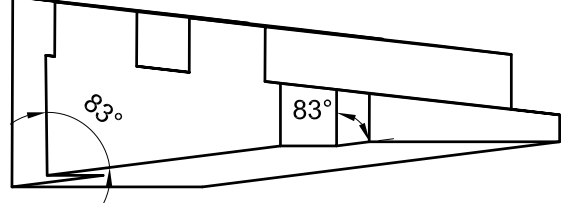
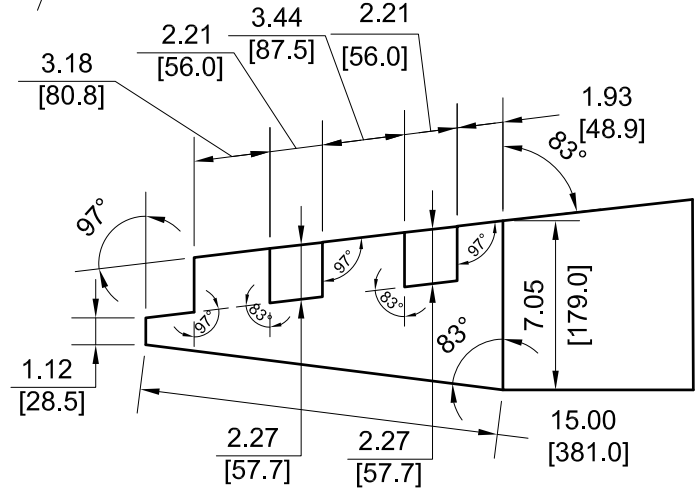

DRAWING NUMBER					AES-D0008	
SIZE	SCALE	SHEET	OF	REVISION		
A3	NONE	79	190	B		

156

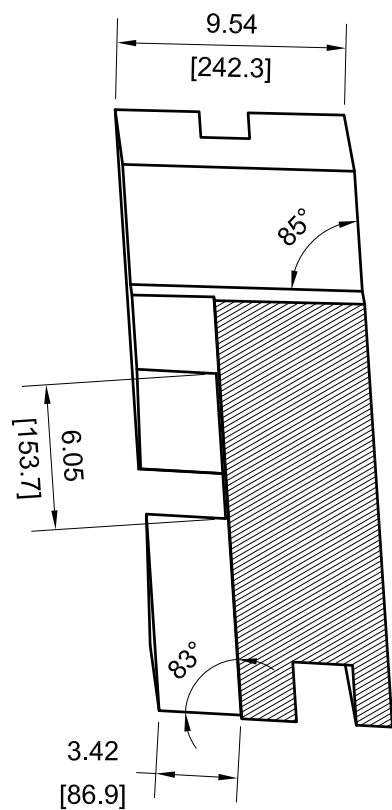

SECTION VIEW D2-80

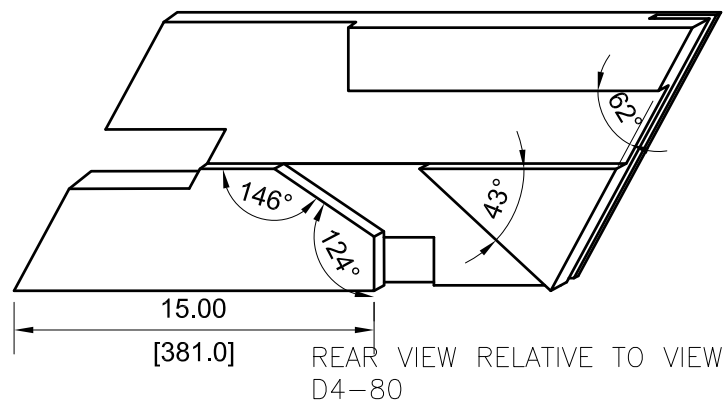

REAR VIEW RELATIVE TO VIEW D4-80

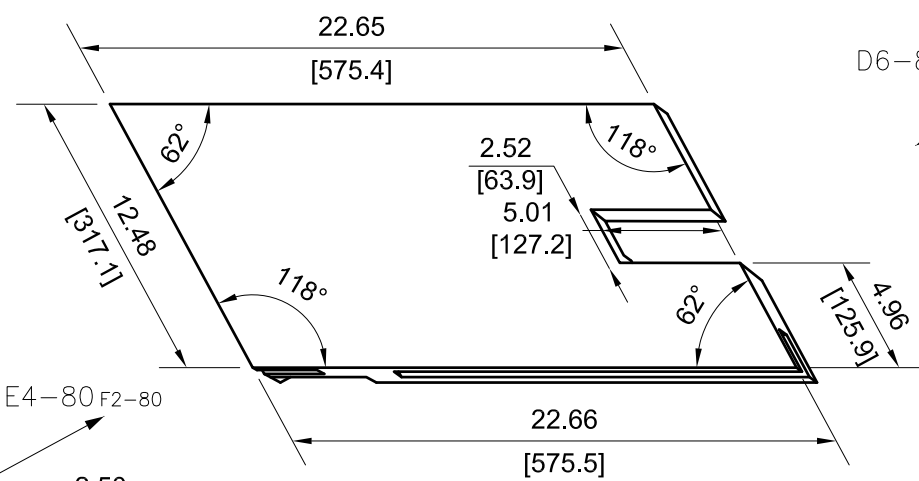
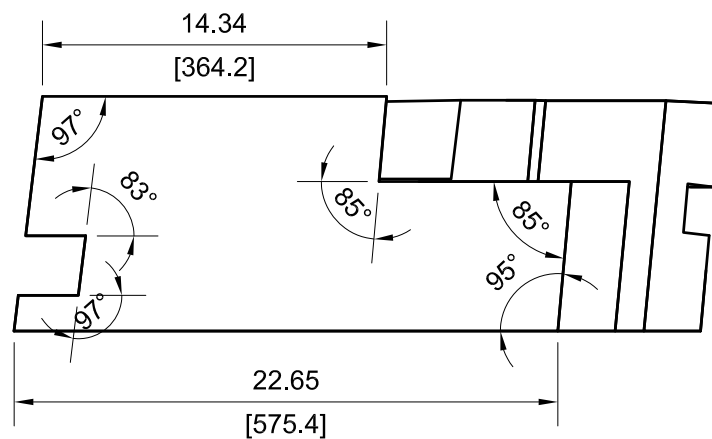
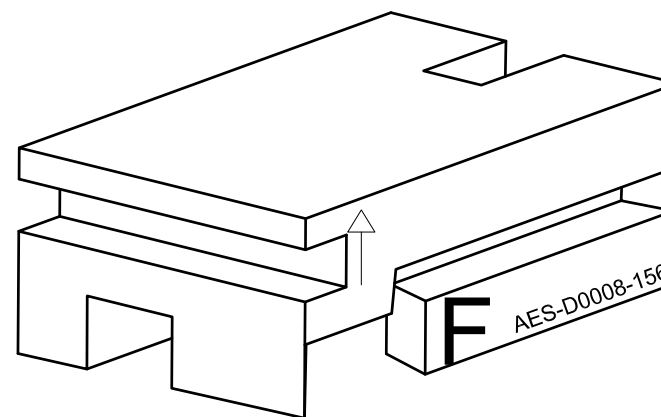

D6-80 D7-80

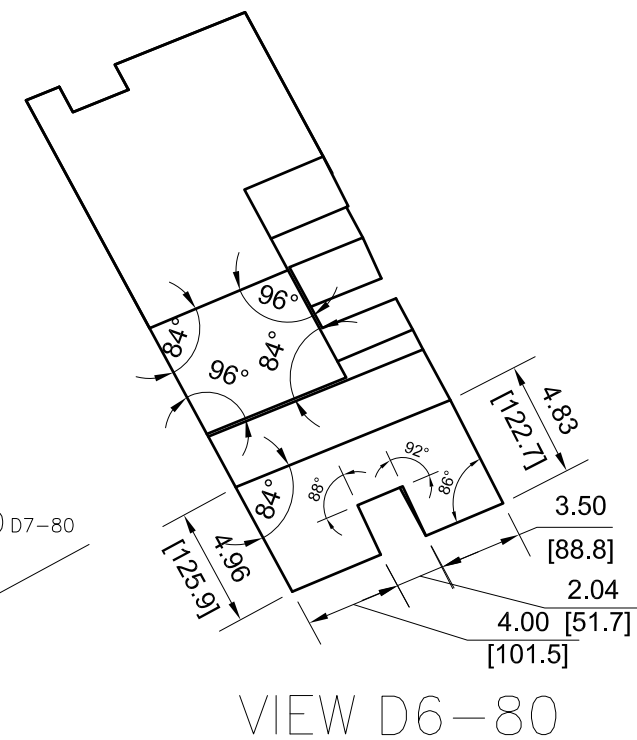

VIEW D6-80

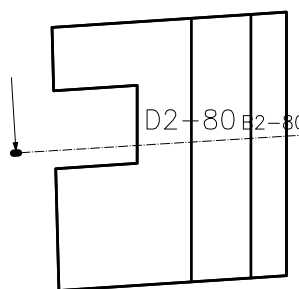

D2-80 E2-80

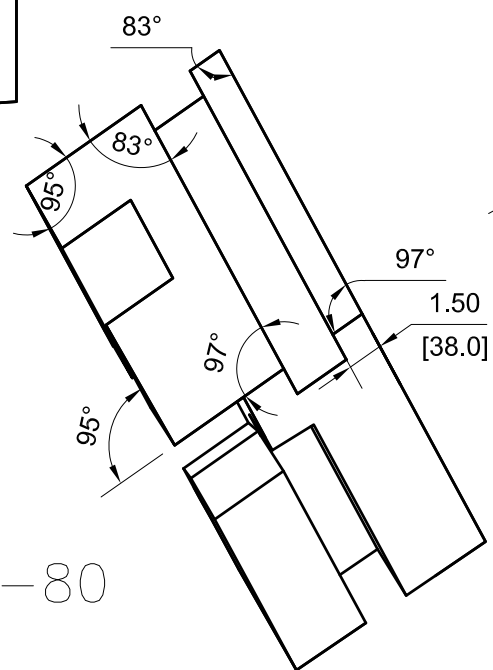

VIEW E4-80

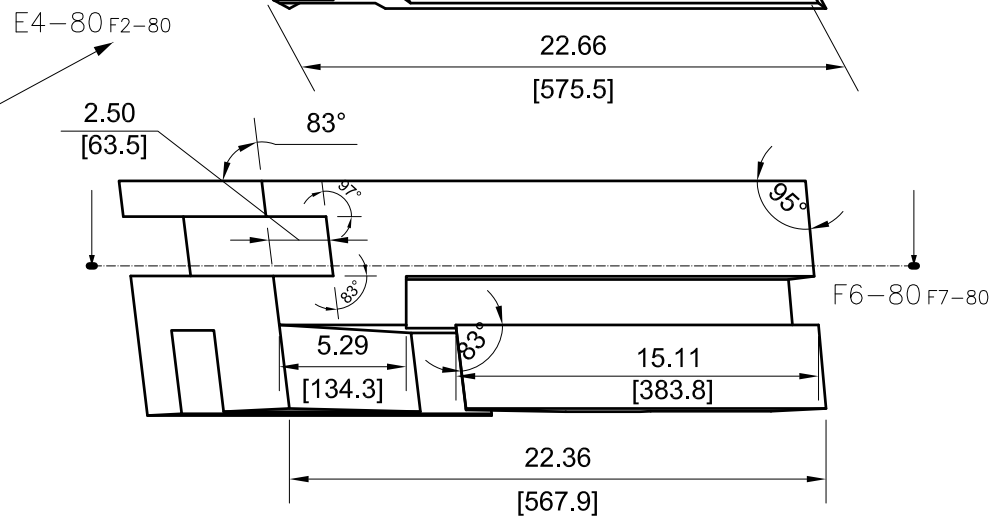

F6-80 F7-80

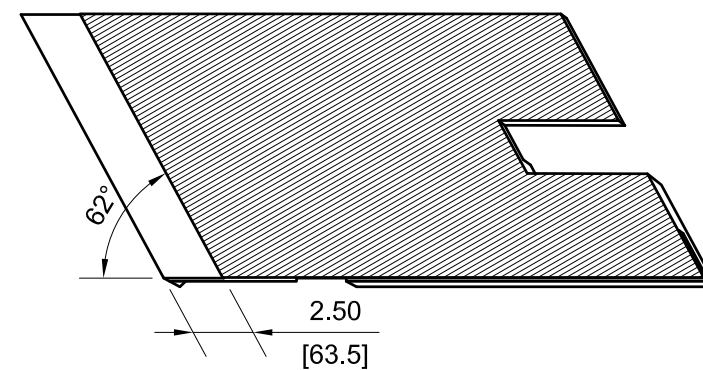

SECTION VIEW F6-80



DRAWING NUMBER				
AES-D0008				
SIZE	SCALE	SHEET	OF	REVISION
A3	NONE	80	190	B

158

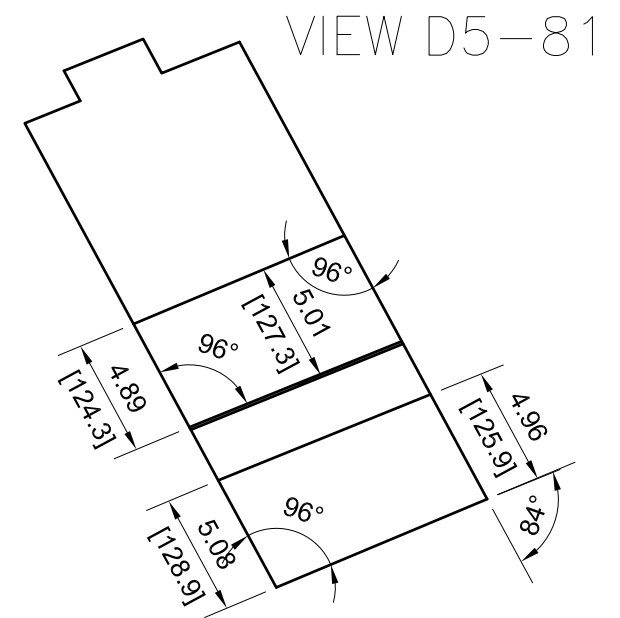
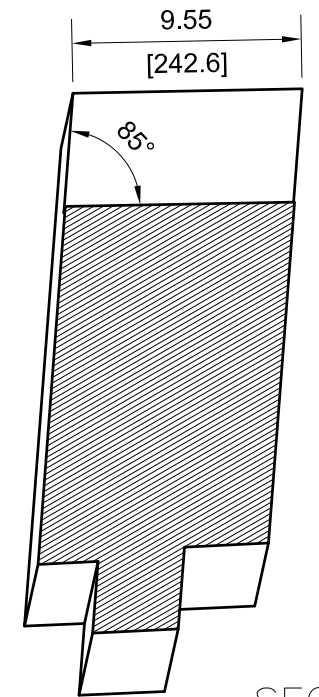
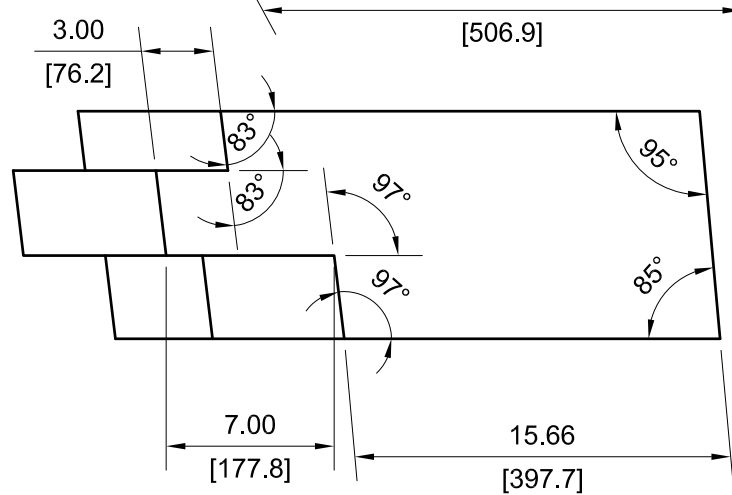
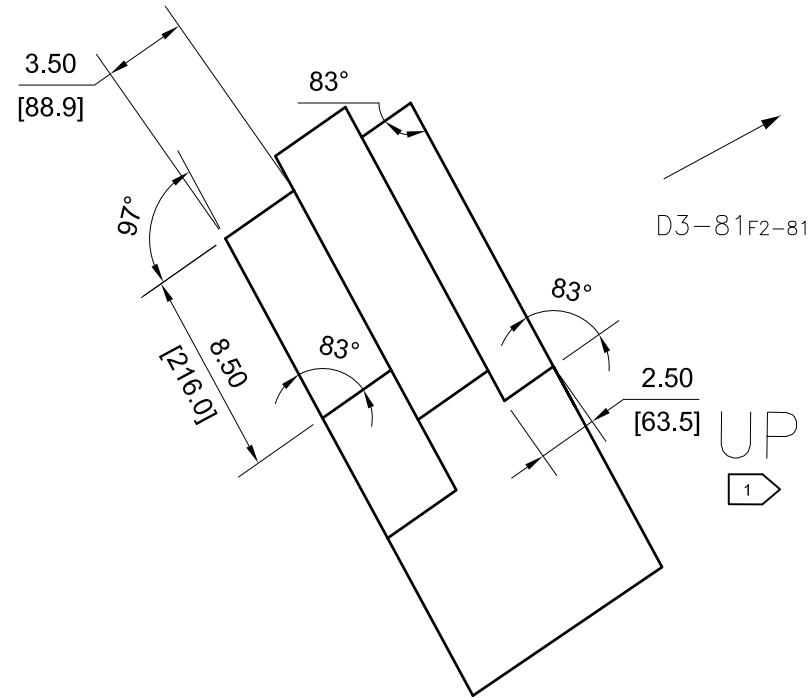
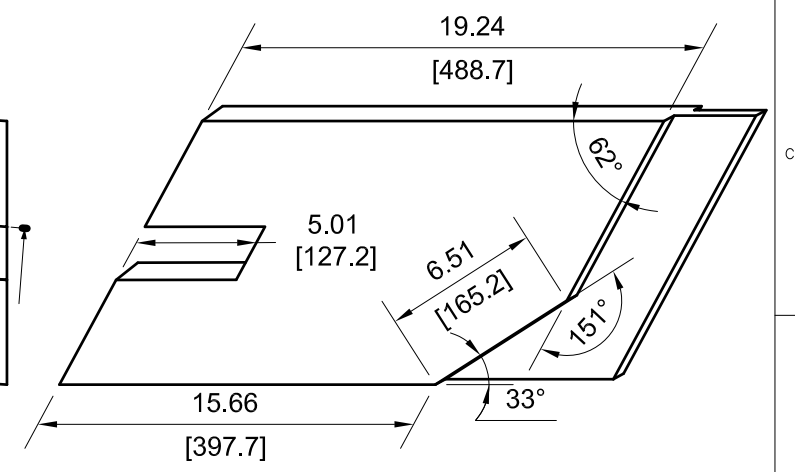
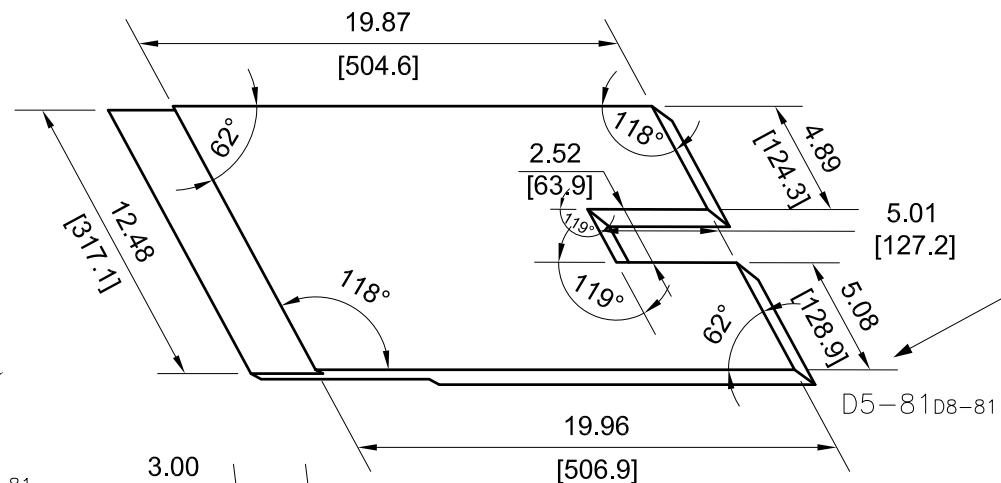
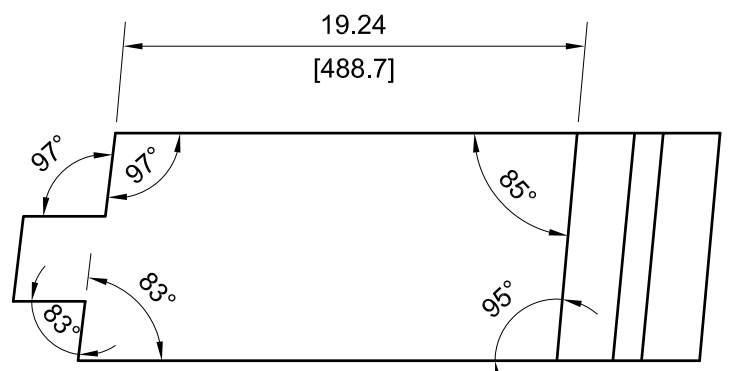
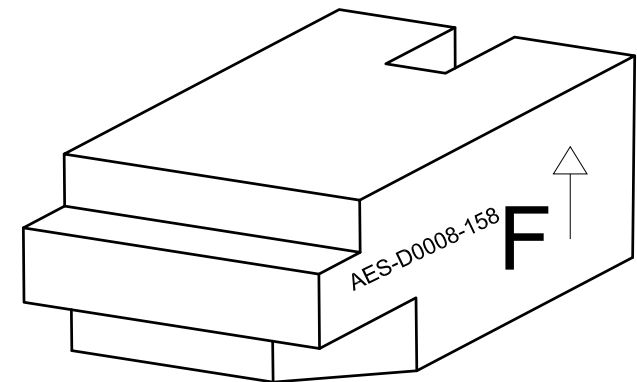

VIEW D3-81

VIEW D5-81

SECTION VIEW C6-81



DRAWING NUMBER					AES-D0008	
SIZE	SCALE	SHEET	OF	REVISION		
A3	NONE	81	190	B		

160

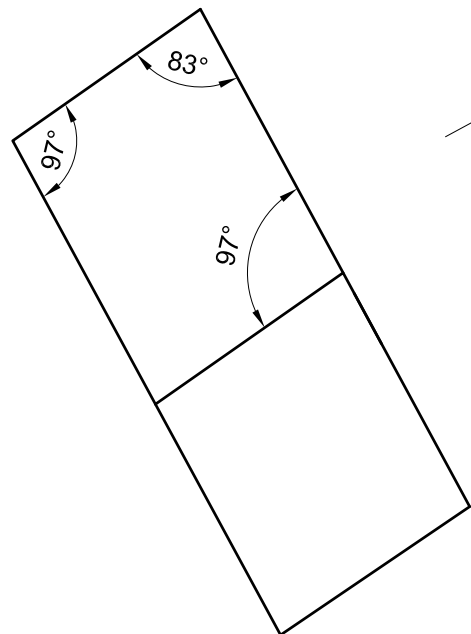
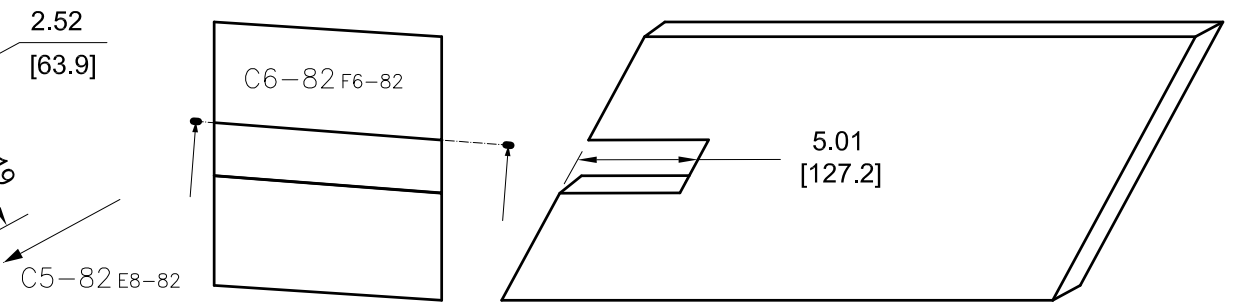
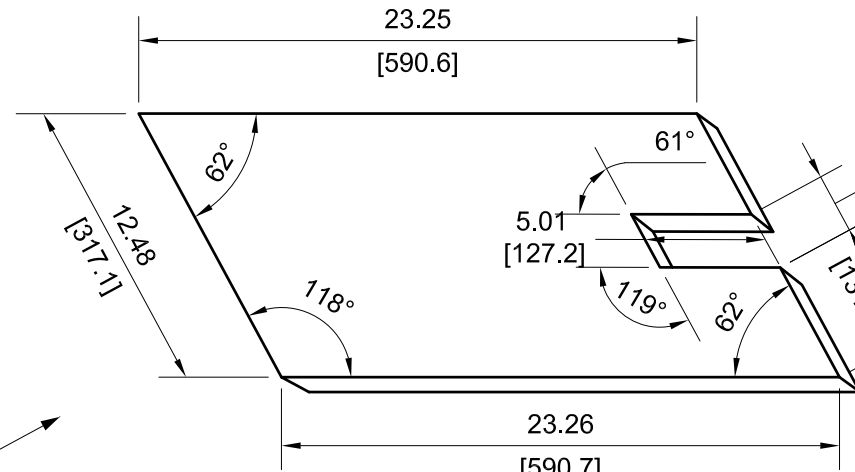
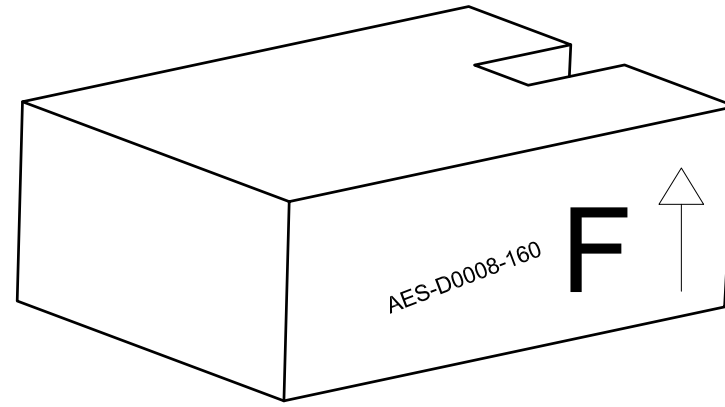
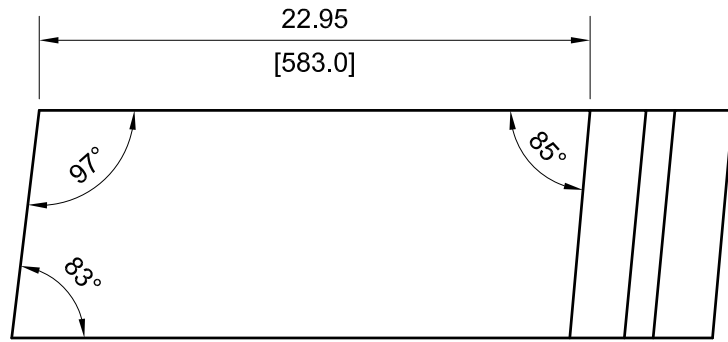

UP
1

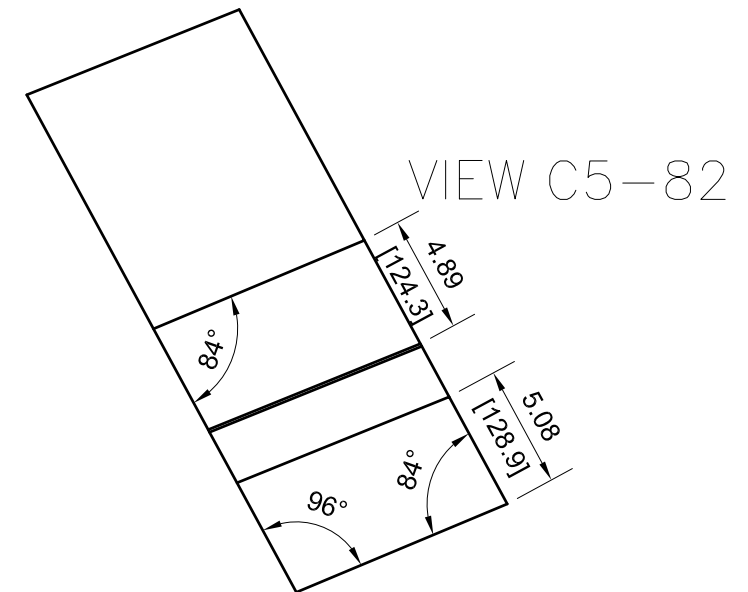
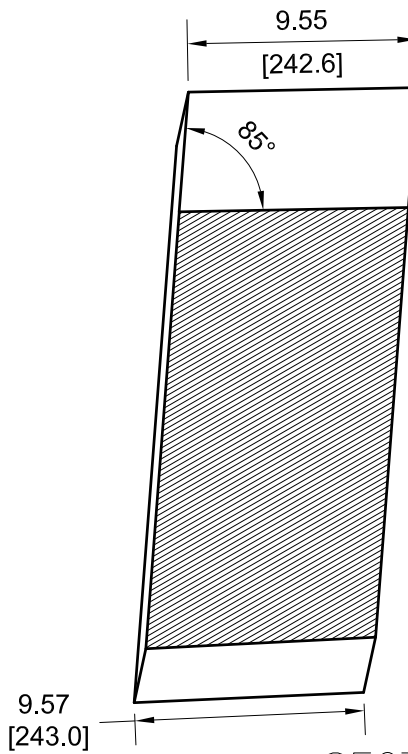
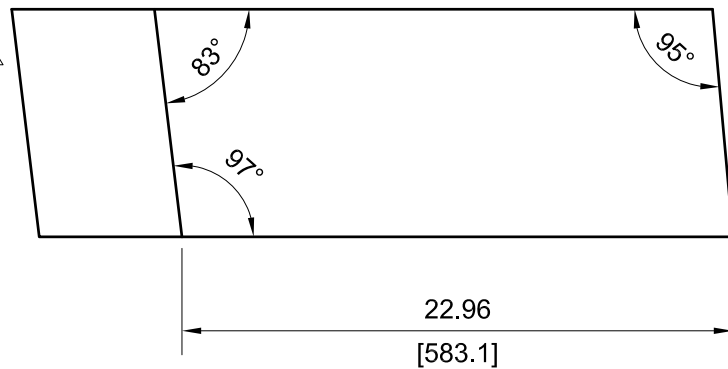

VIEW D3-82

SECTION VIEW C6-82



DRAWING NUMBER				
AES-D0008				
SIZE	SCALE	SHEET	OF	REVISION
A3	NONE	82	190	B

162

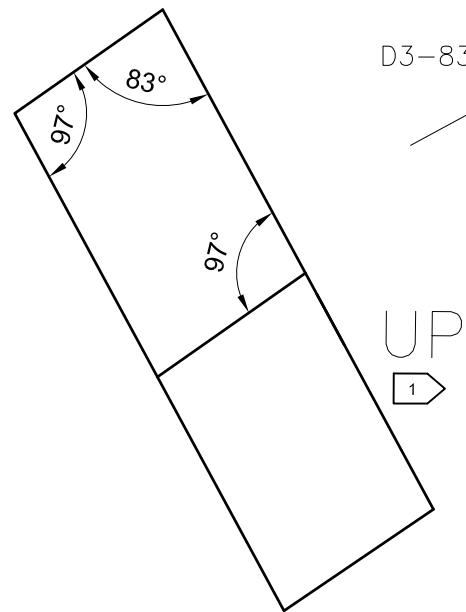
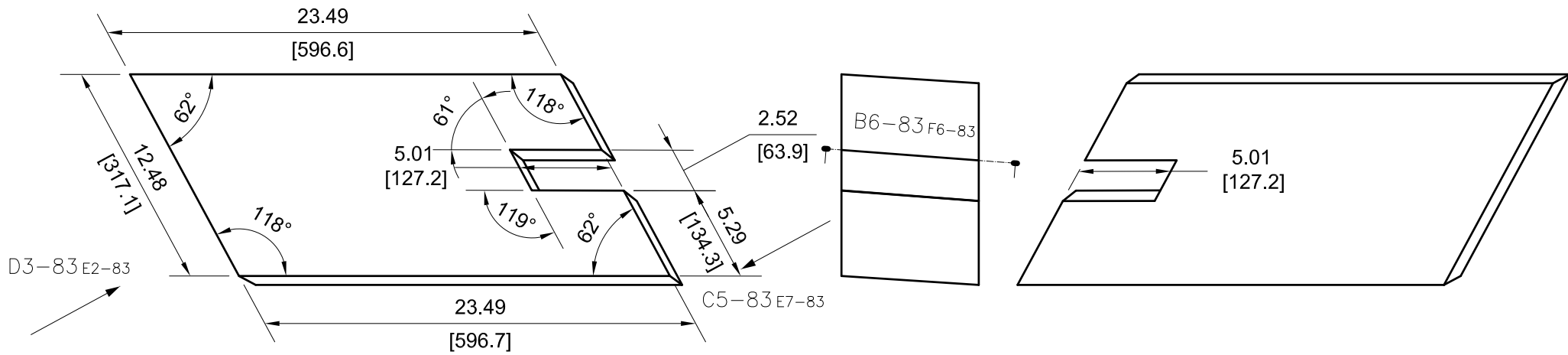
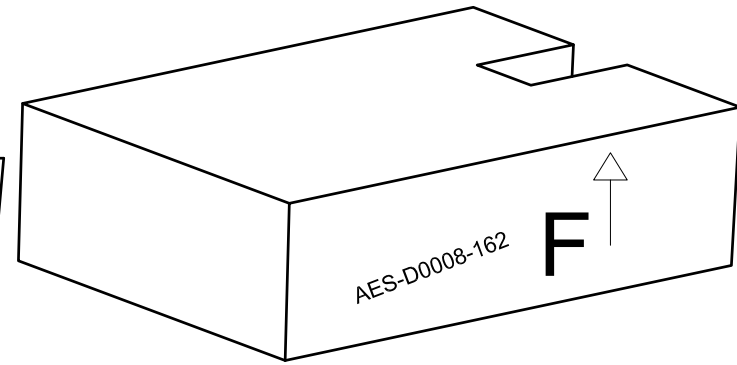
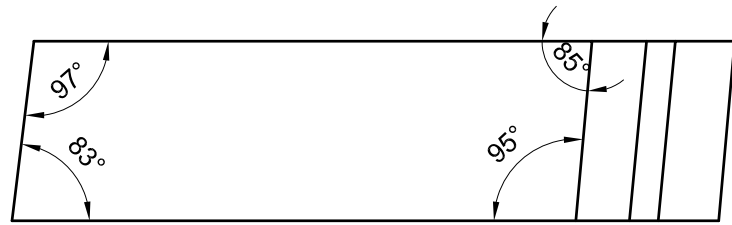

VIEW D3-83

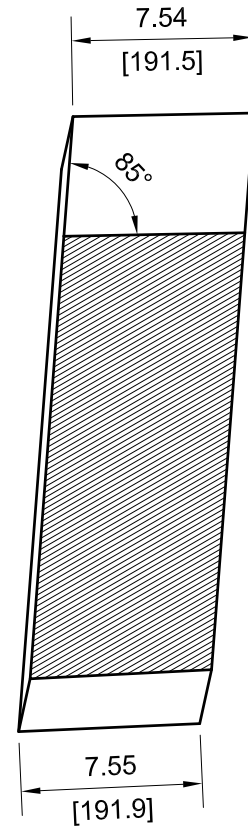
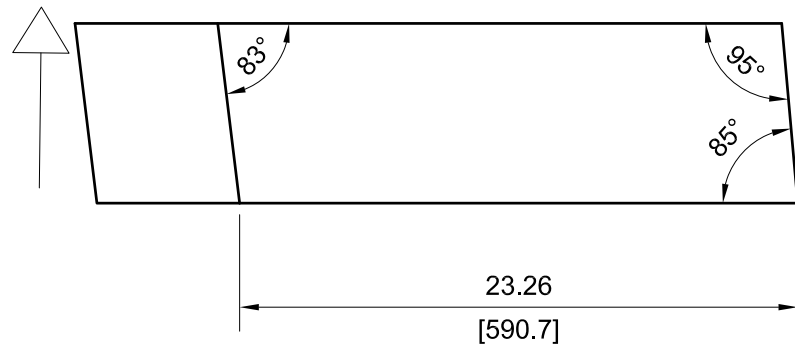

SECTION VIEW B6-83

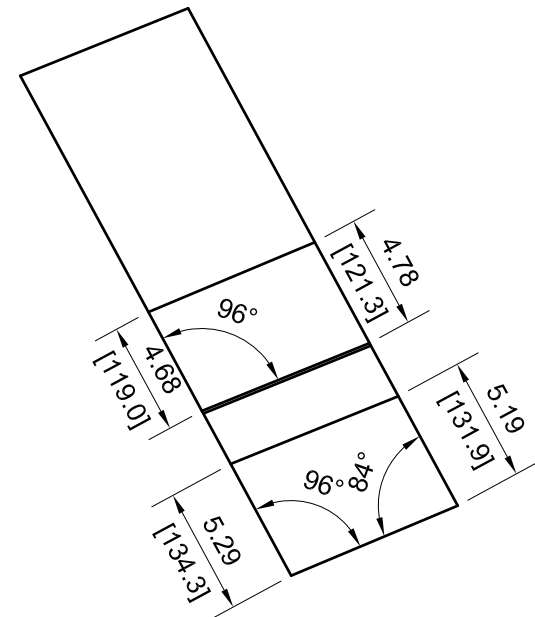

VIEW C5-83



DRAWING NUMBER				
AES-D0008				
SIZE	SCALE	SHEET	OF	REVISION
A3	NONE	83	190	B

164

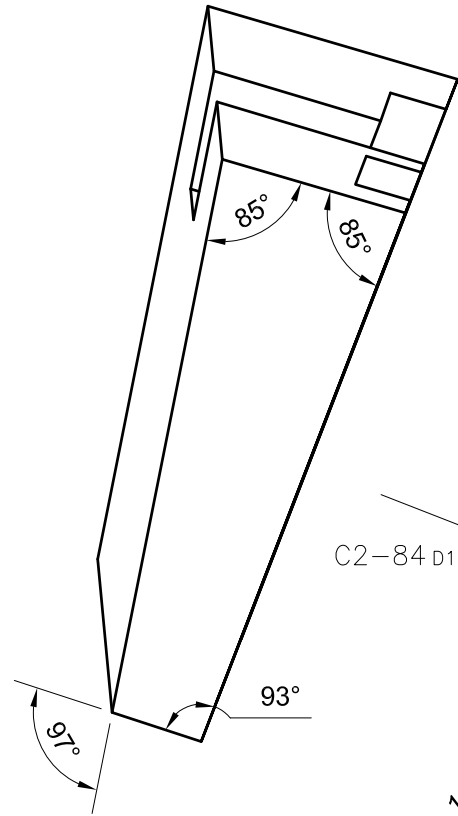

VIEW C2-84

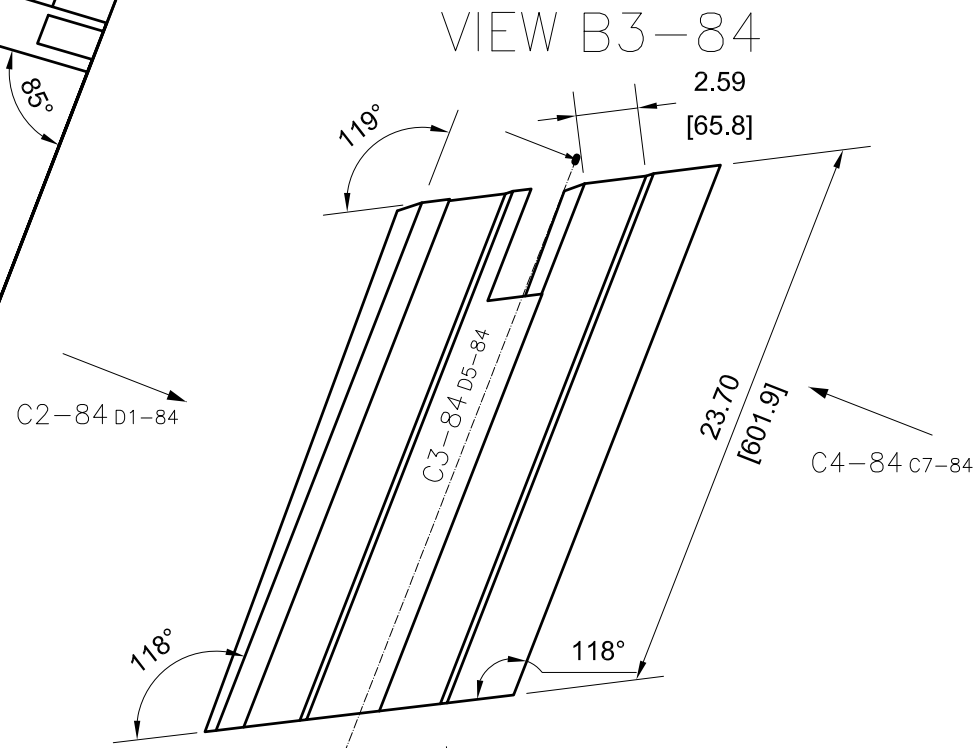

VIEW B3-84

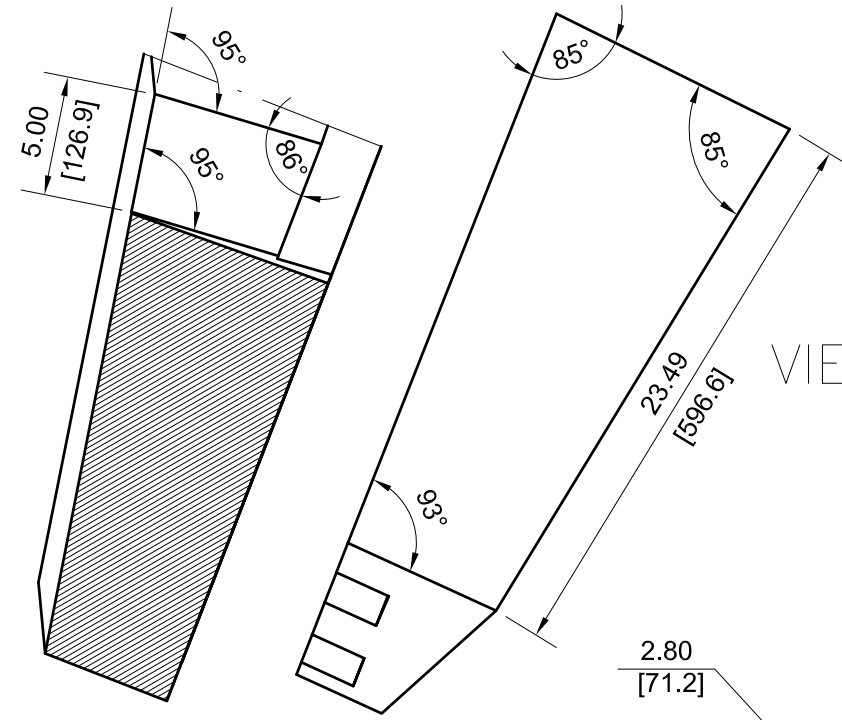
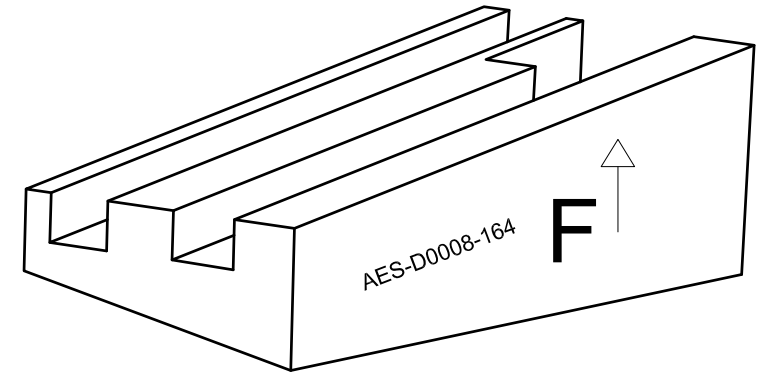

SECTION VIEW C3-84

VIEW C4-84

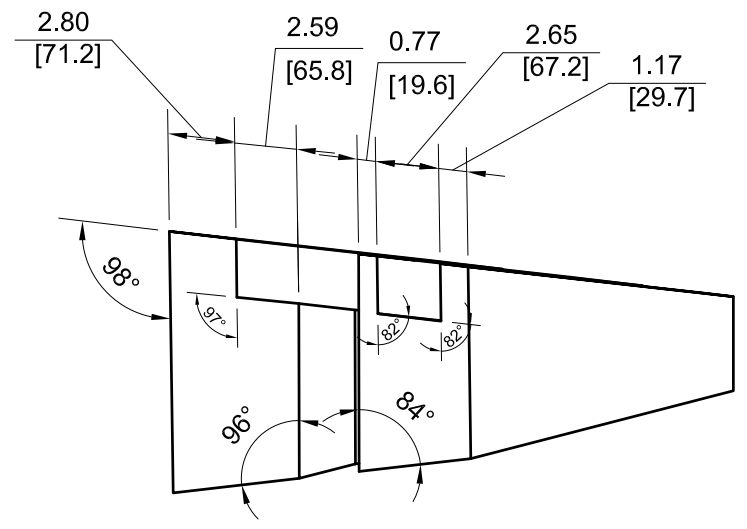
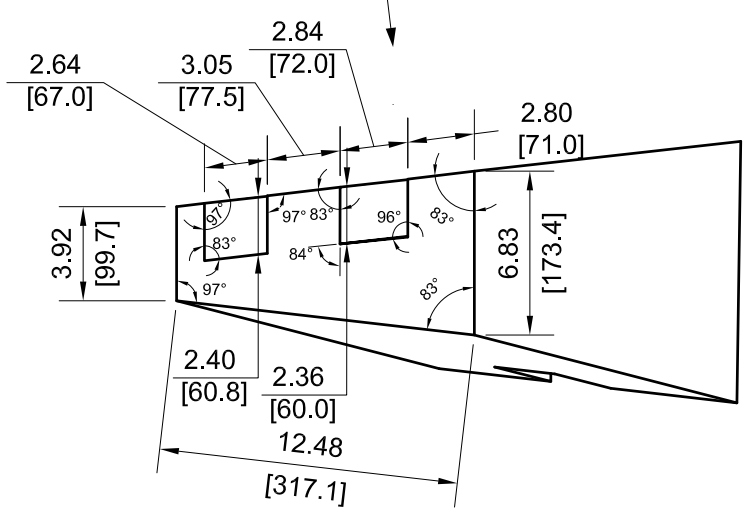

DRAWING NUMBER				
AES-D0008				
SIZE	SCALE	SHEET	OF	REVISION
A3	NONE	84	190	B

— 166

THIS PART IS MADE OBSOLETE.



DRAWING NUMBER					AES-D0008				
SIZE	SCALE	SHEET	OF	REVISION					
A3	NONE	85	190	B					

168

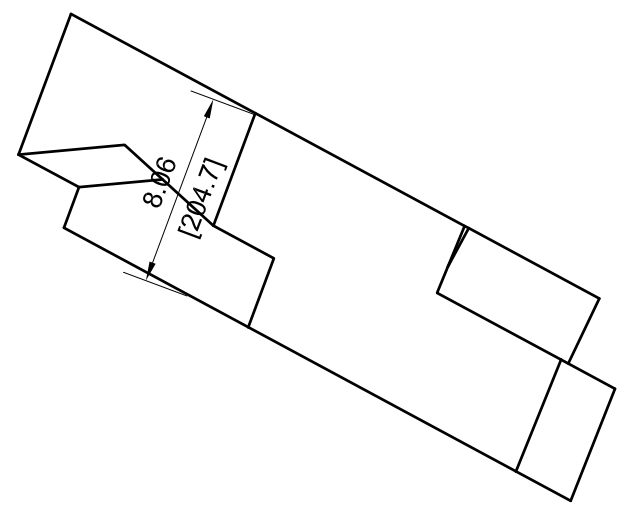

VIEW E3-86

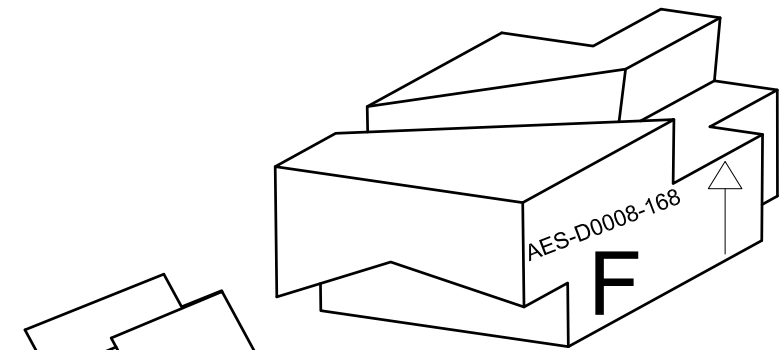

VIEW C6-86

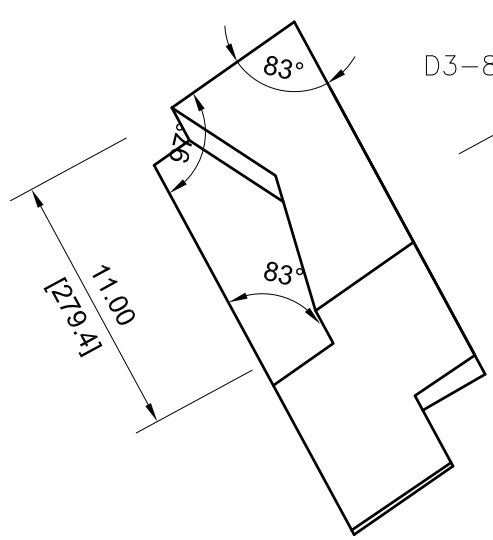

VIEW D3-86

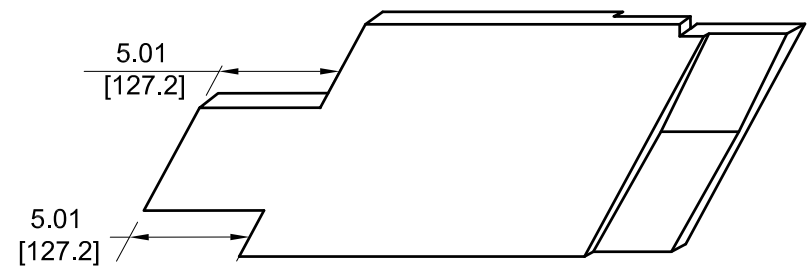
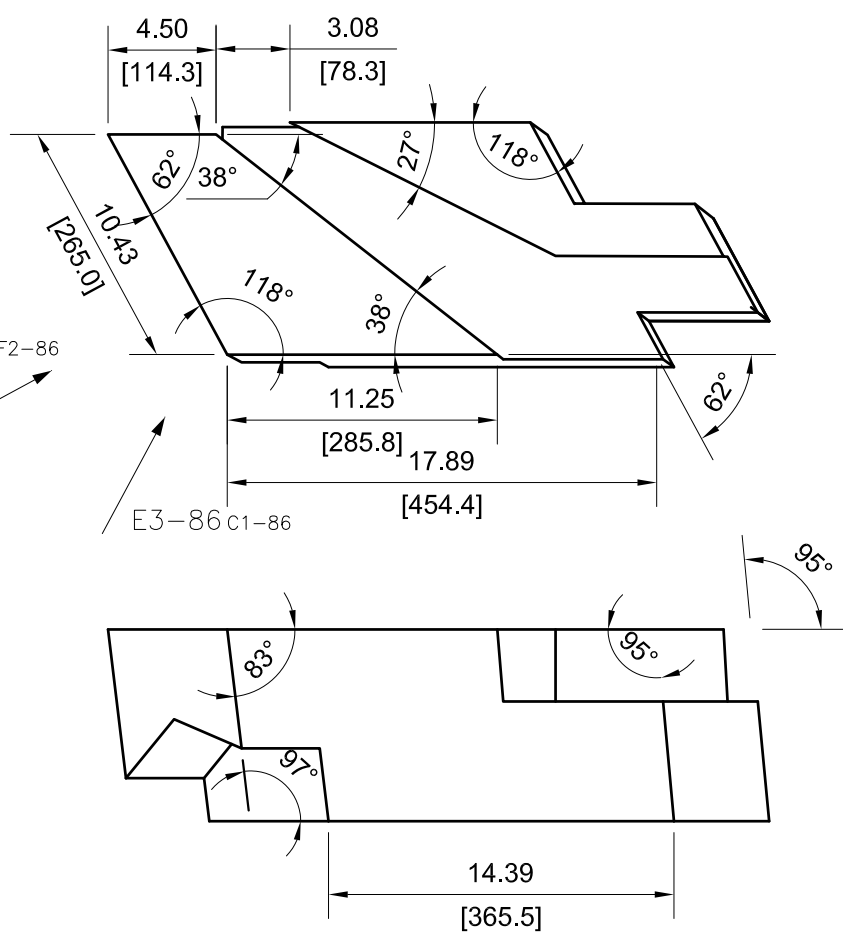

REAR VIEW RELATIVE TO VIEW D4-86



DRAWING NUMBER					AES-D0008	
SIZE	SCALE	SHEET	OF	REVISION		
A3	NONE	86	190	B		

170

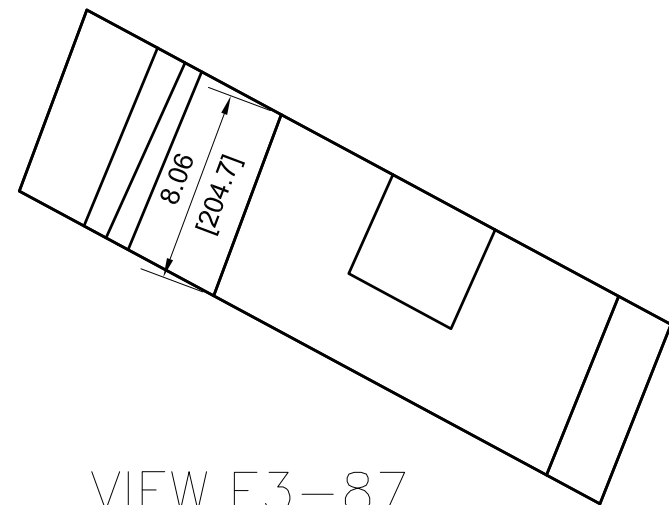

VIEW E3-87

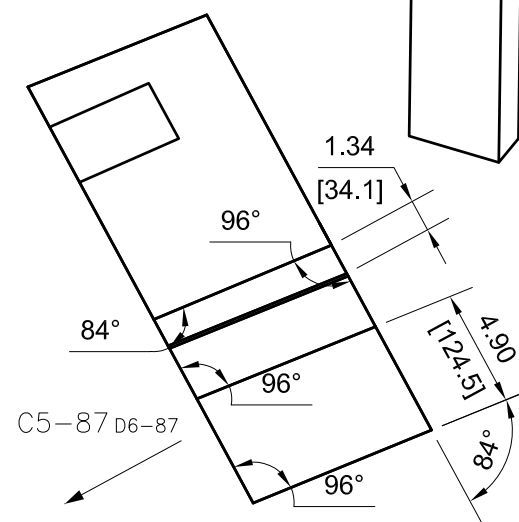
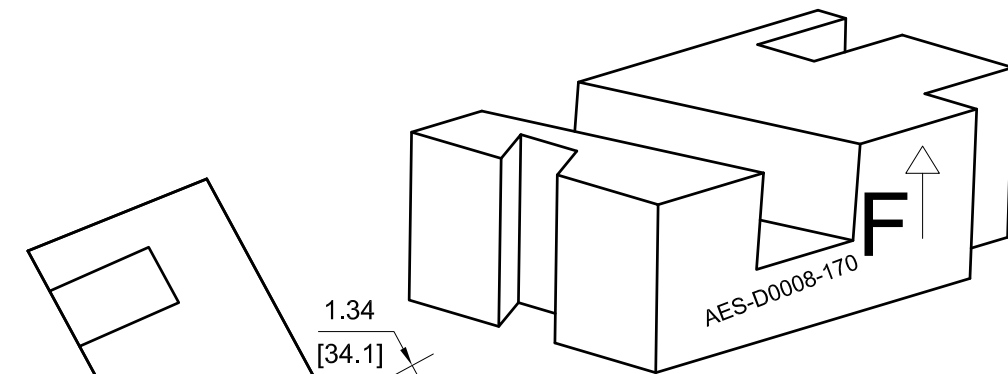
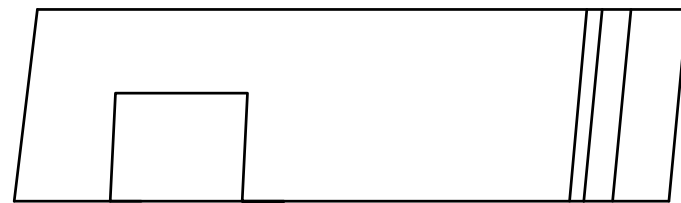

VIEW C5-87

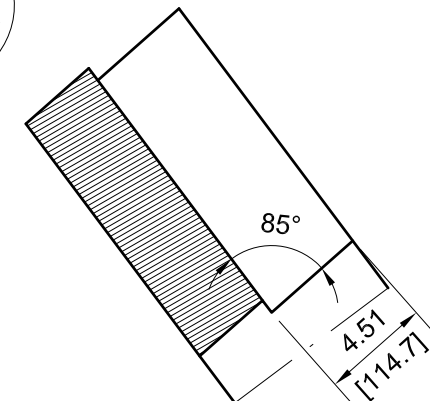

SECTION VIEW C3-87

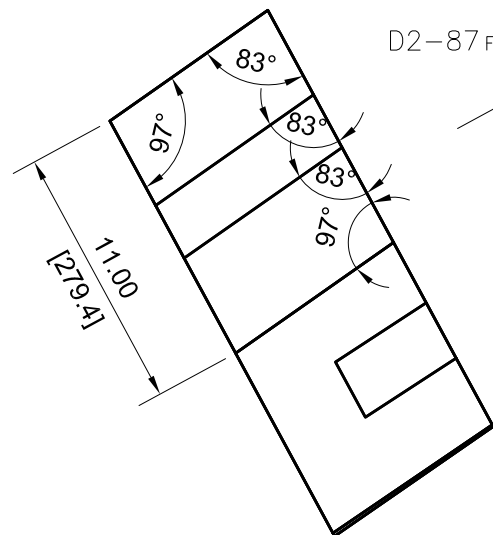
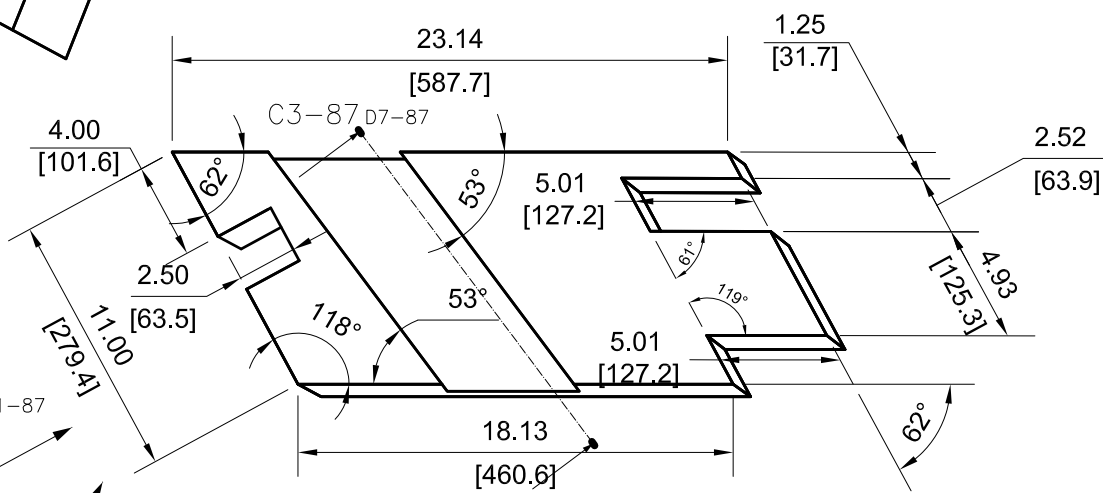

VIEW D2-87

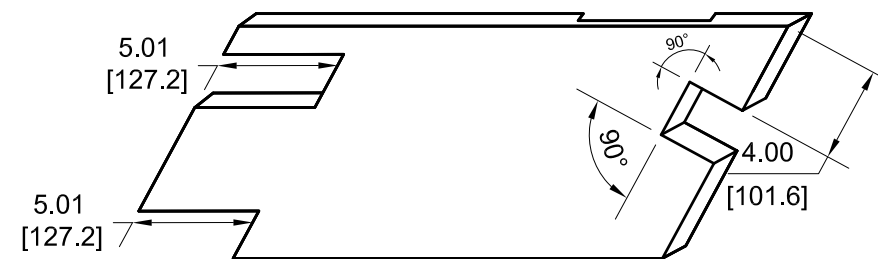
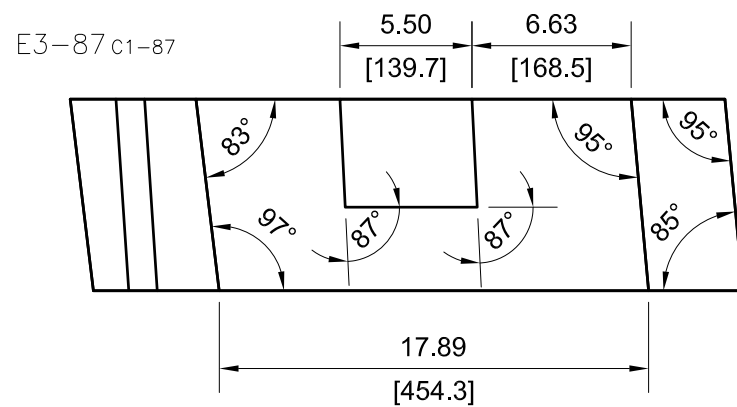

REAR VIEW RELATIVE TO VIEW D4-87

	DRAWING NUMBER				
	AES-D0008				
SIZE	SCALE	SHEET	OF	REVISION	
A3	NONE	87	190	B	

-172

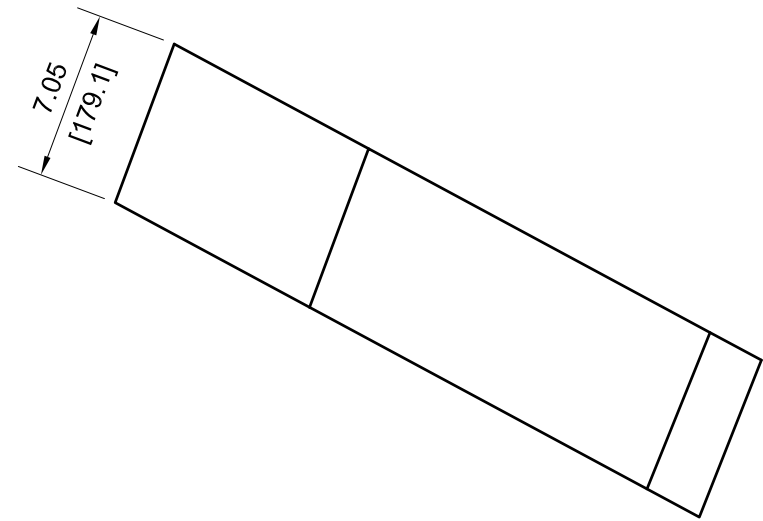

VIEW E3-88

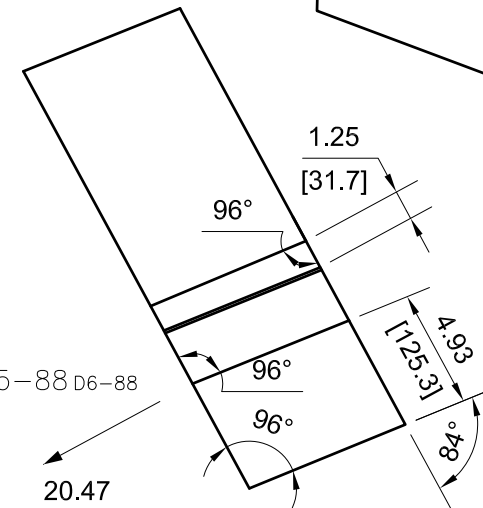
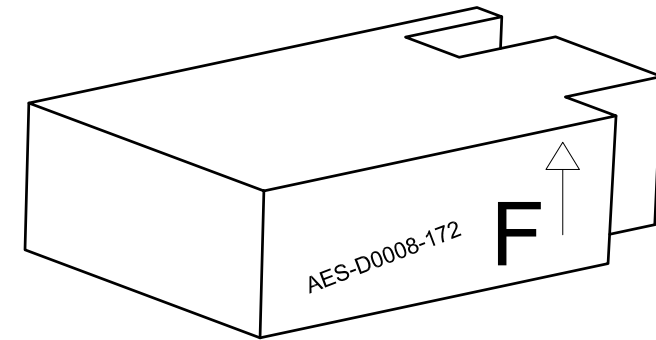

VIEW C5-88

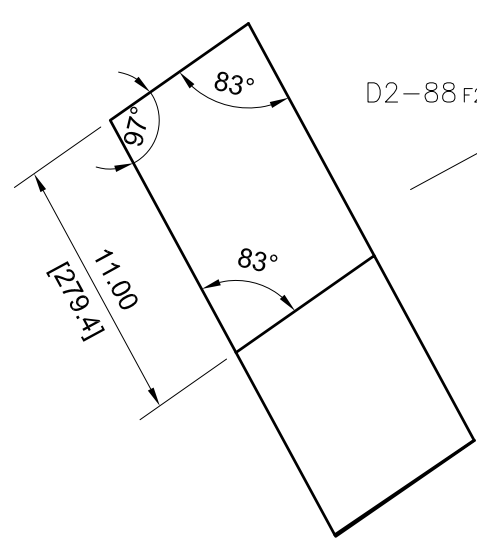
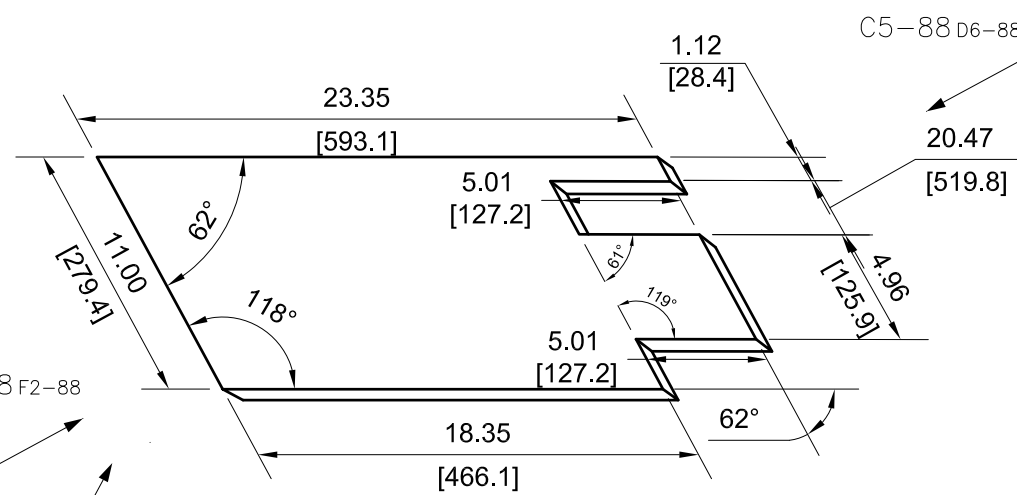

VIEW D2-88

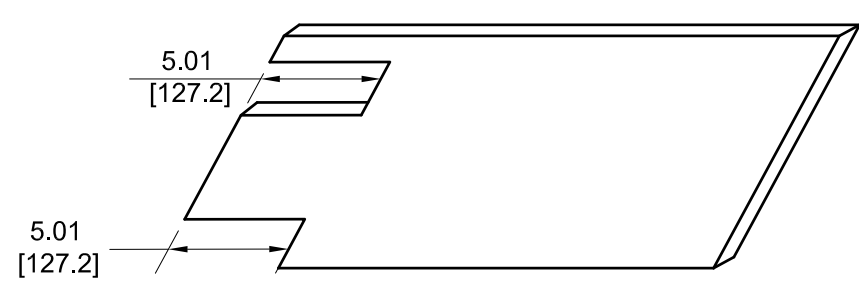
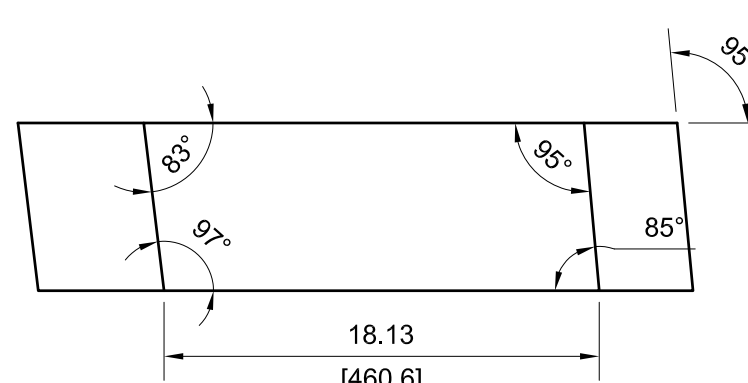

REAR VIEW RELATIVE TO VIEW D4-88



DRAWING NUMBER					AES-D0008				
SIZE	SCALE	SHEET	OF	REVISION					
A3	NONE	88	190	B					

174

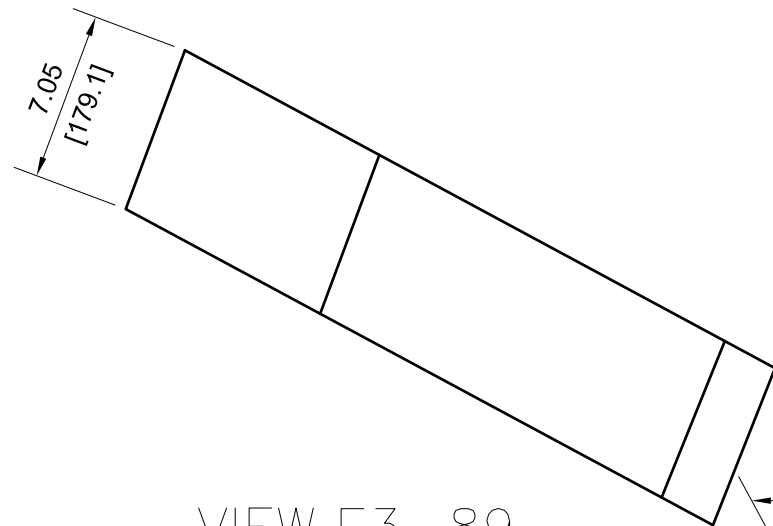
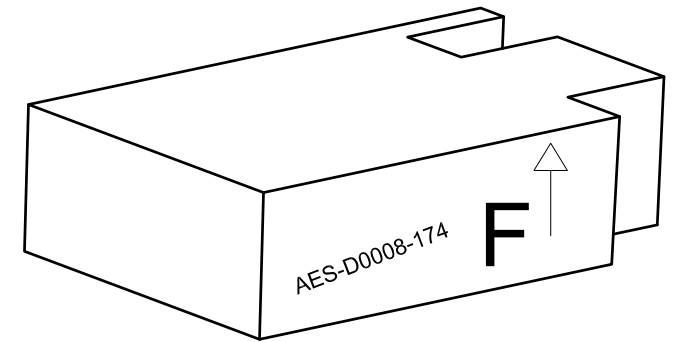

VIEW E3-89

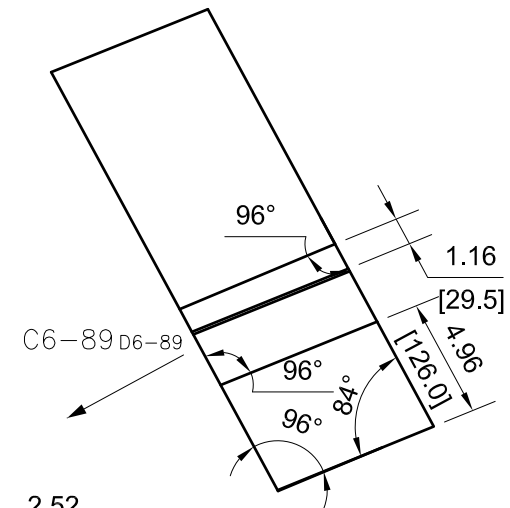

VIEW C6-89

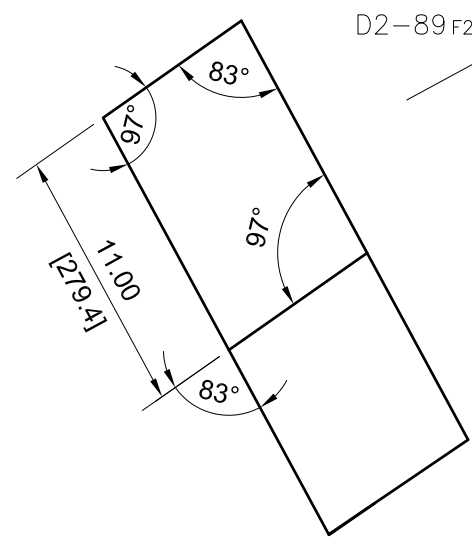

VIEW D2-89

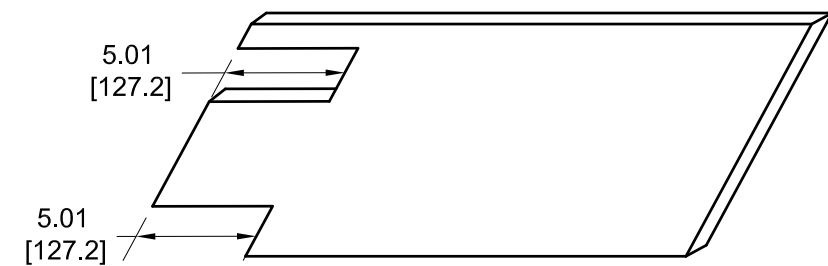
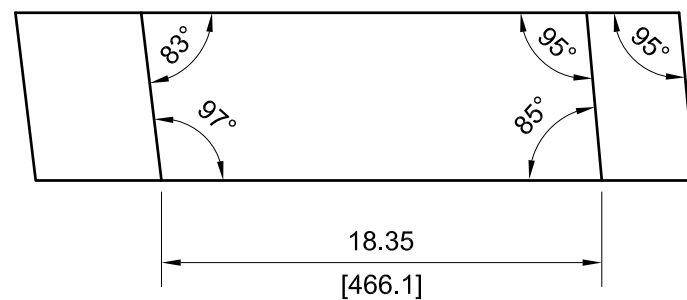
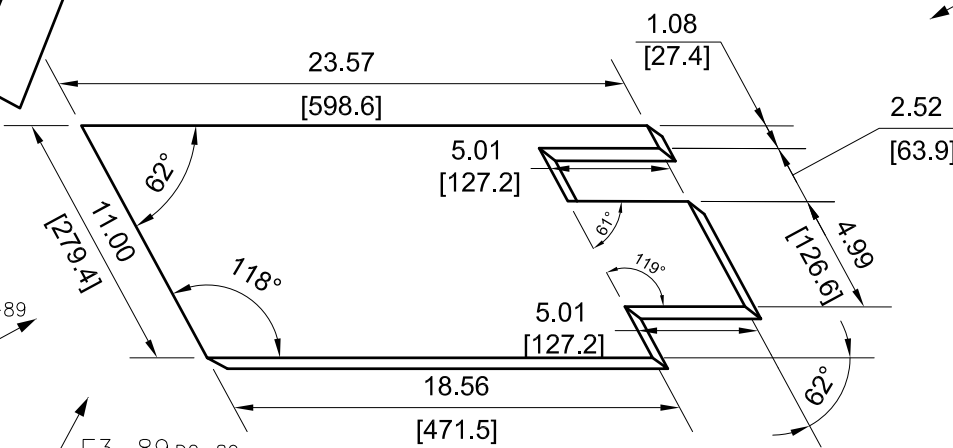

REAR VIEW RELATIVE TO VIEW D4-89



DRAWING NUMBER				
AES-D0008				
SIZE	SCALE	SHEET	OF	REVISION
A3	NONE	89	190	B

176

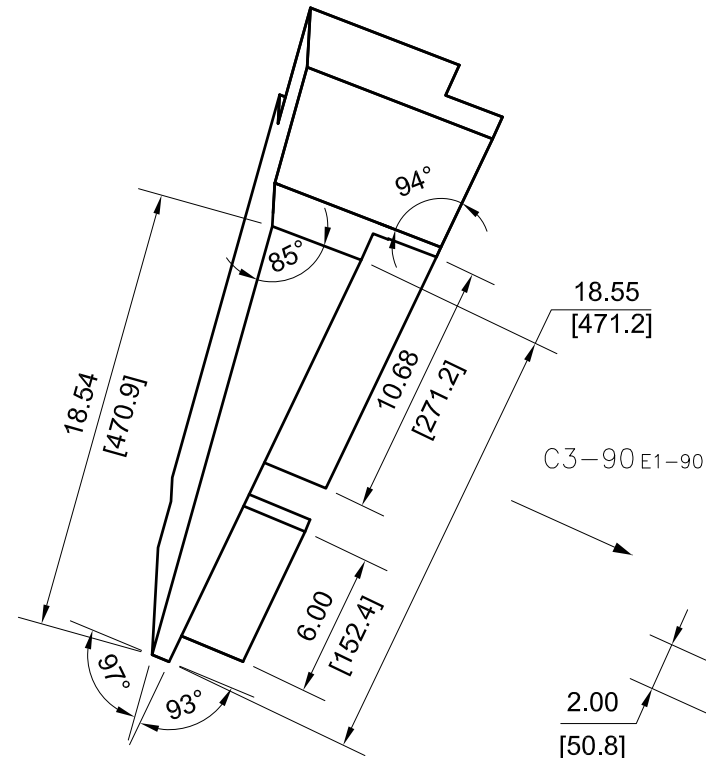

VIEW C3-90

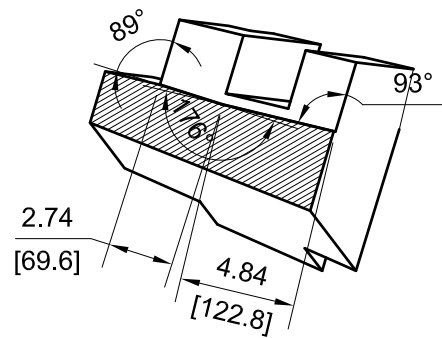

SECTION VIEW D3-90

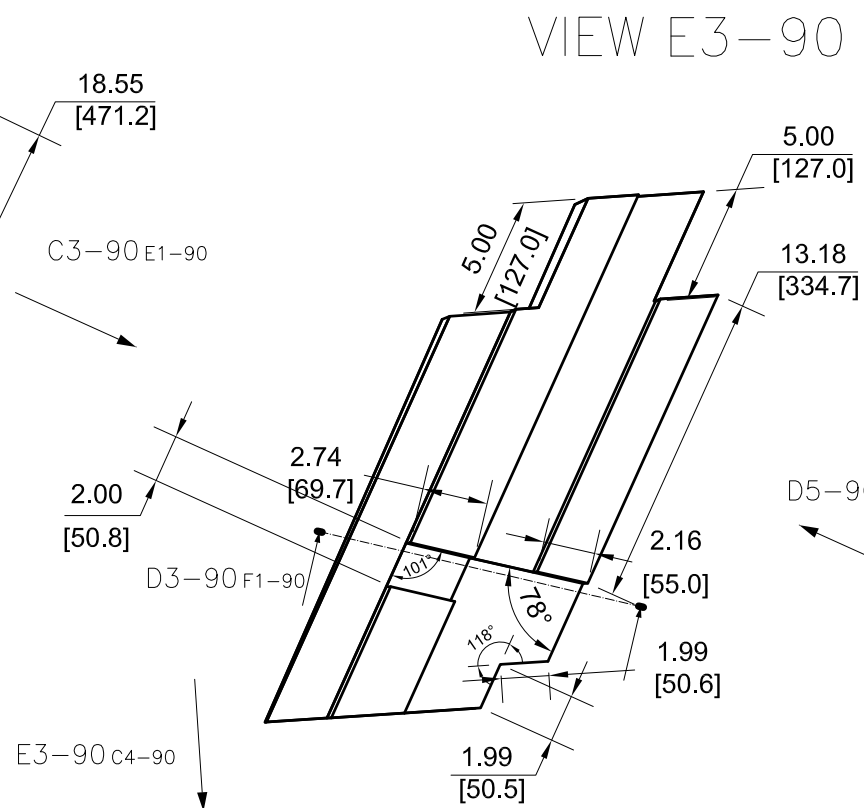

VIEW E3-90

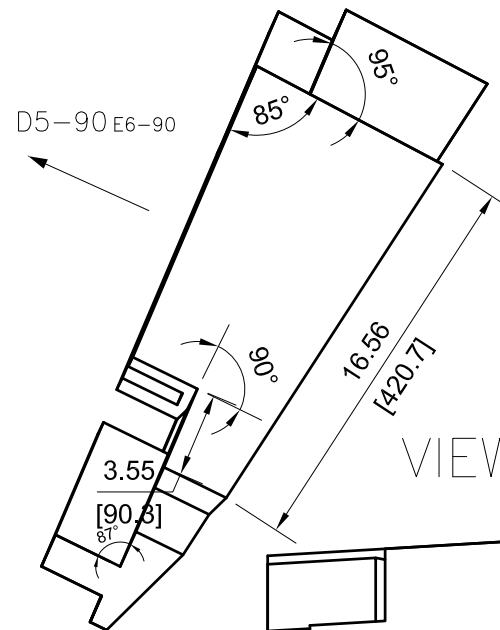
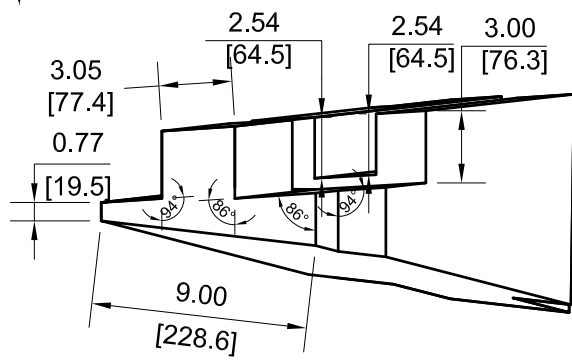

VIEW D5-90

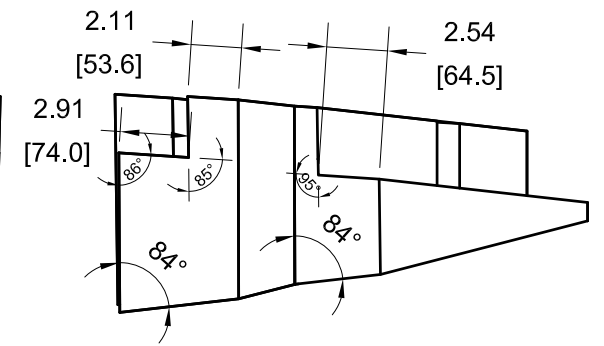
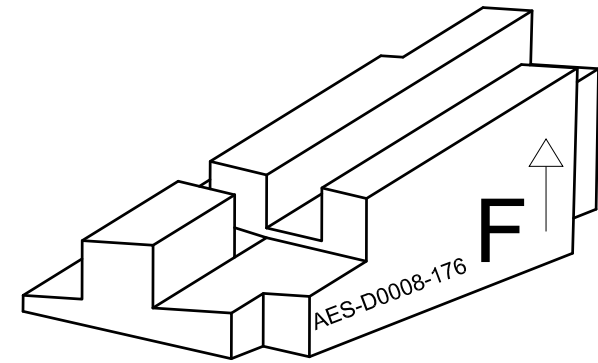

DRAWING NUMBER				
AES-D0008				
SIZE	SCALE	SHEET	OF	REVISION
A3	NONE	90	190	B

— 1 7 8

THIS PART IS MADE OBSOLETE.



DRAWING NUMBER					AES-D0008	
SIZE	SCALE	SHEET	OF	REVISION		
A3	NONE	91	190	B		

180

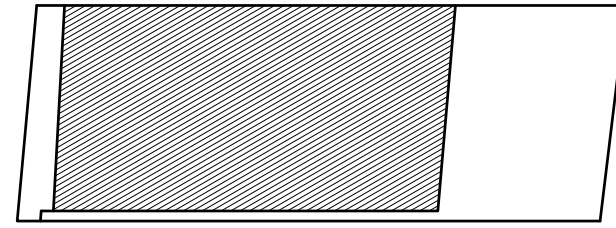

SECTION VIEW E7-92

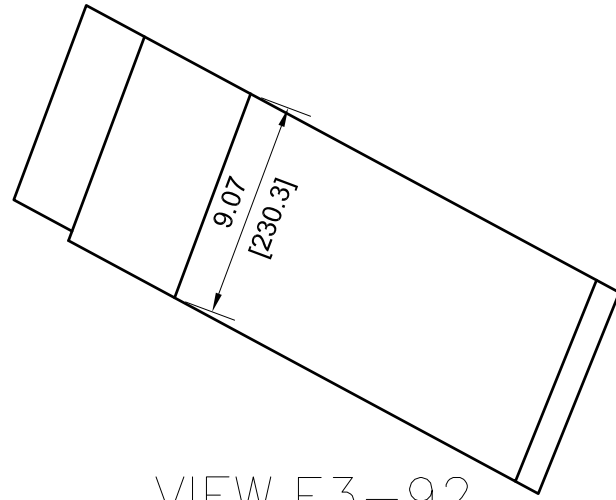

VIEW E3-92

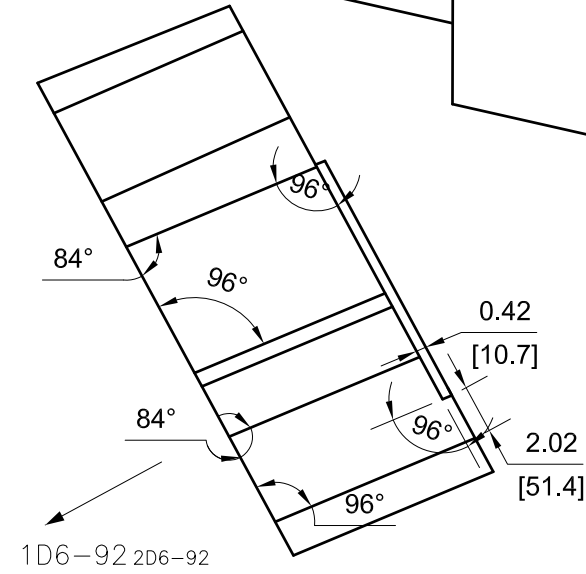
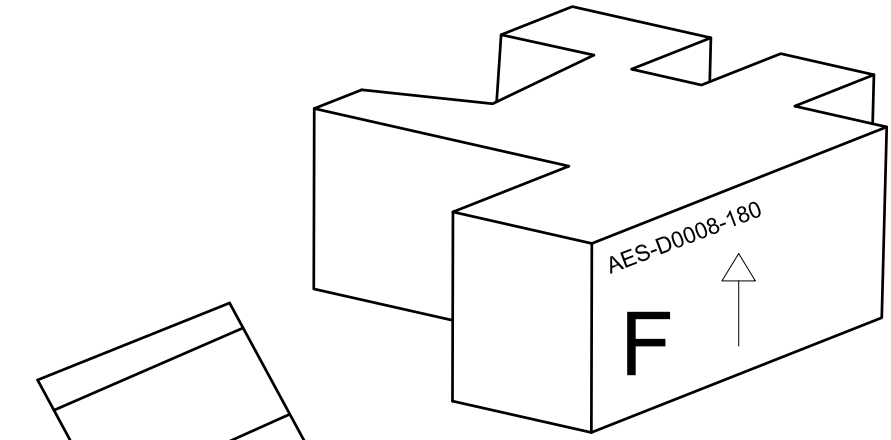
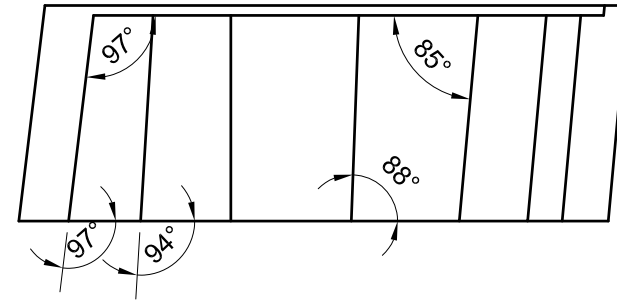

VIEW 1D6-92

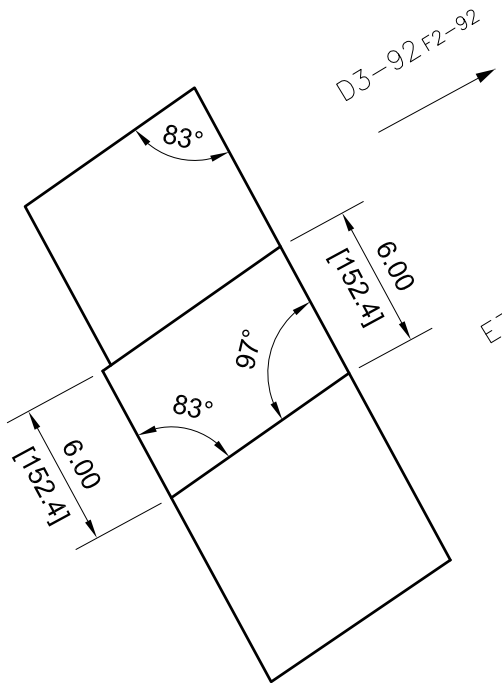

VIEW D3-92

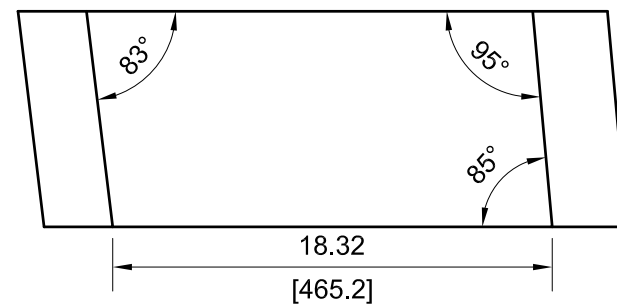
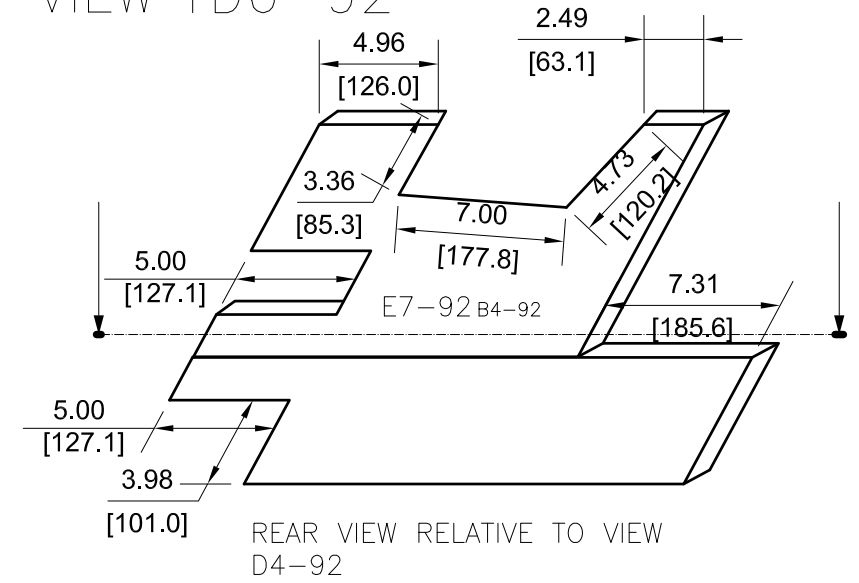
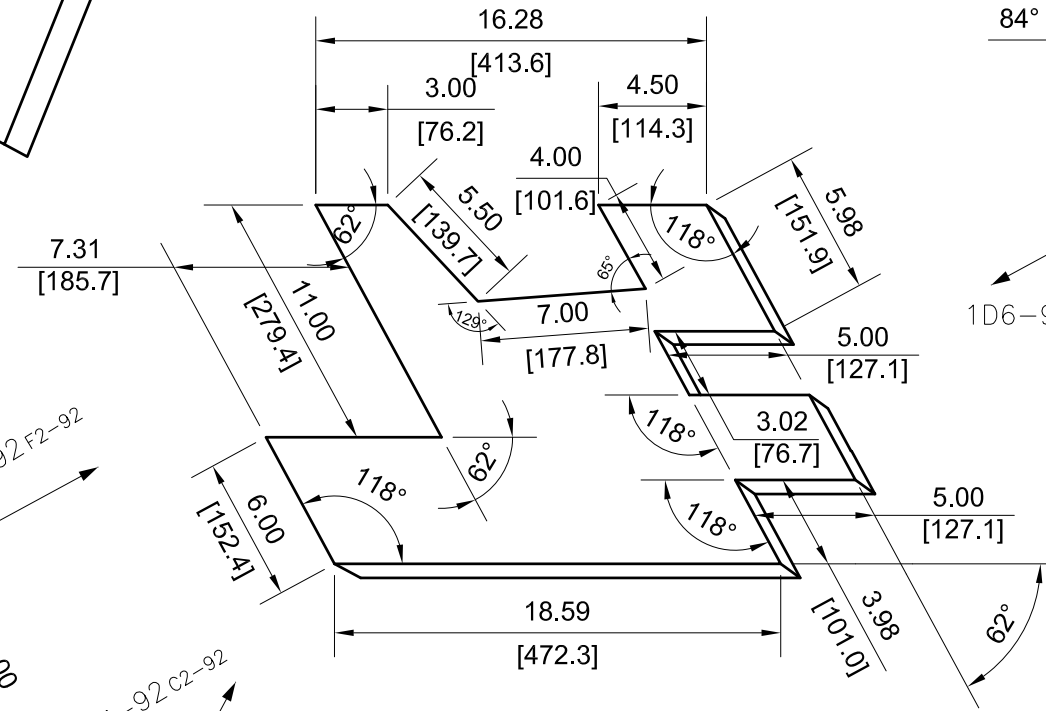

		DRAWING NUMBER			
		AES-D0008			
SIZE	SCALE	SHEET	OF	REVISION	
A3	NONE	92	190	B	

182

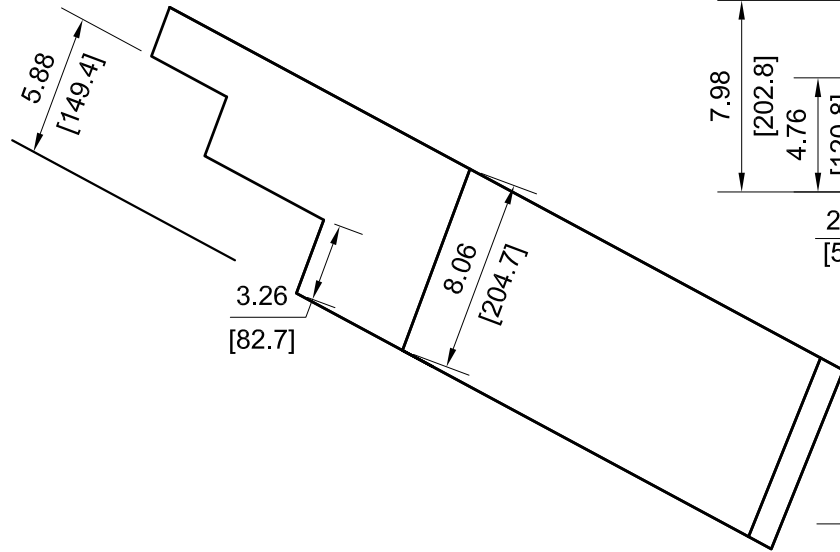

VIEW 1D3-93

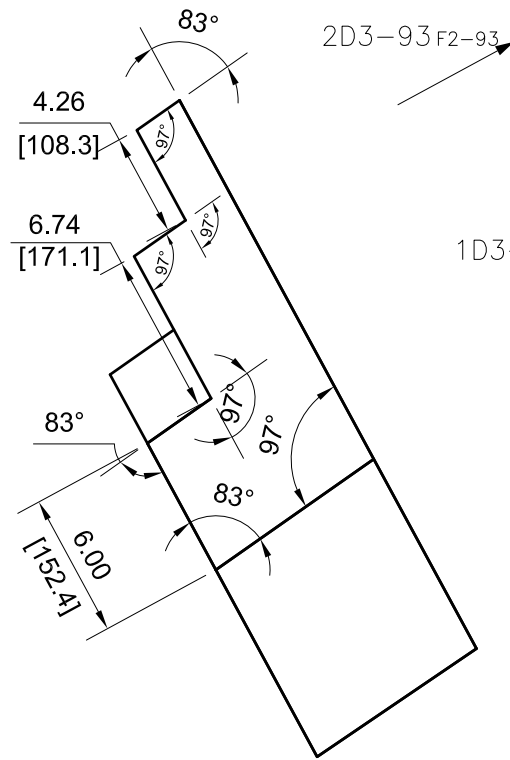
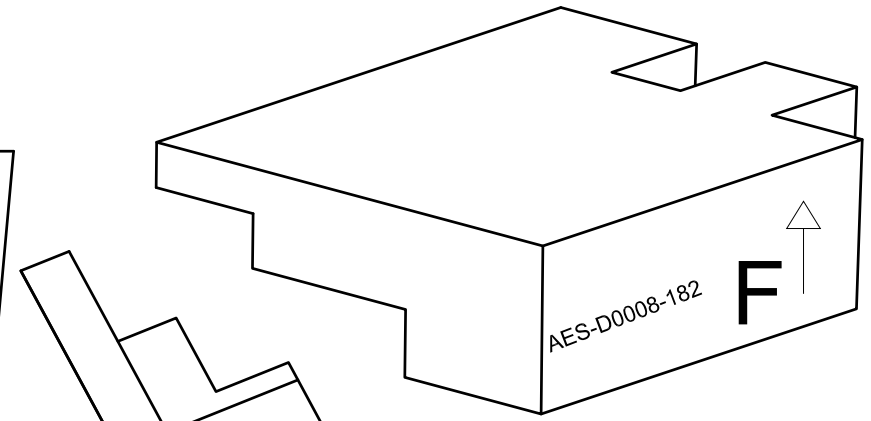
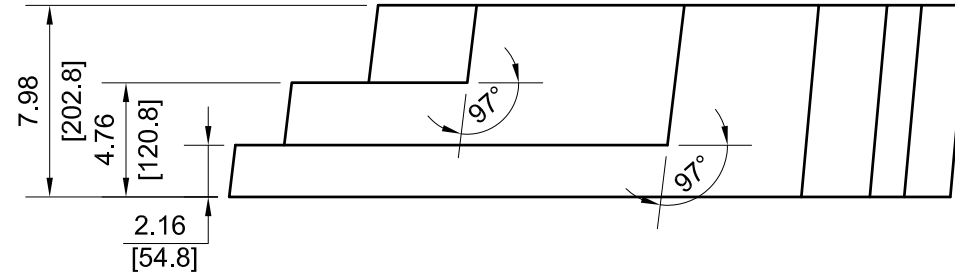

VIEW 2D3-93

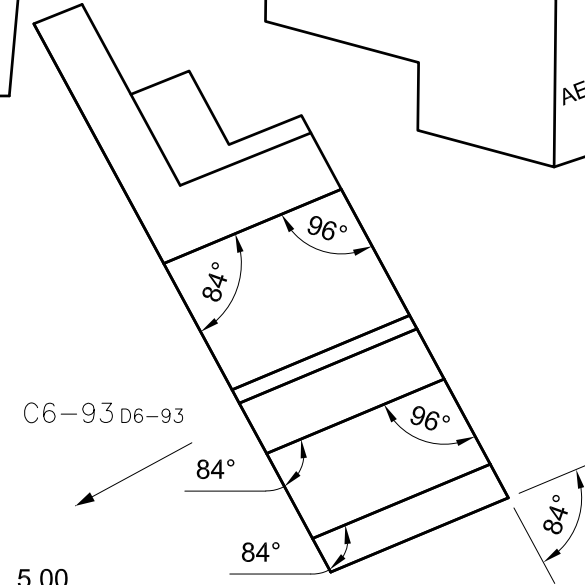
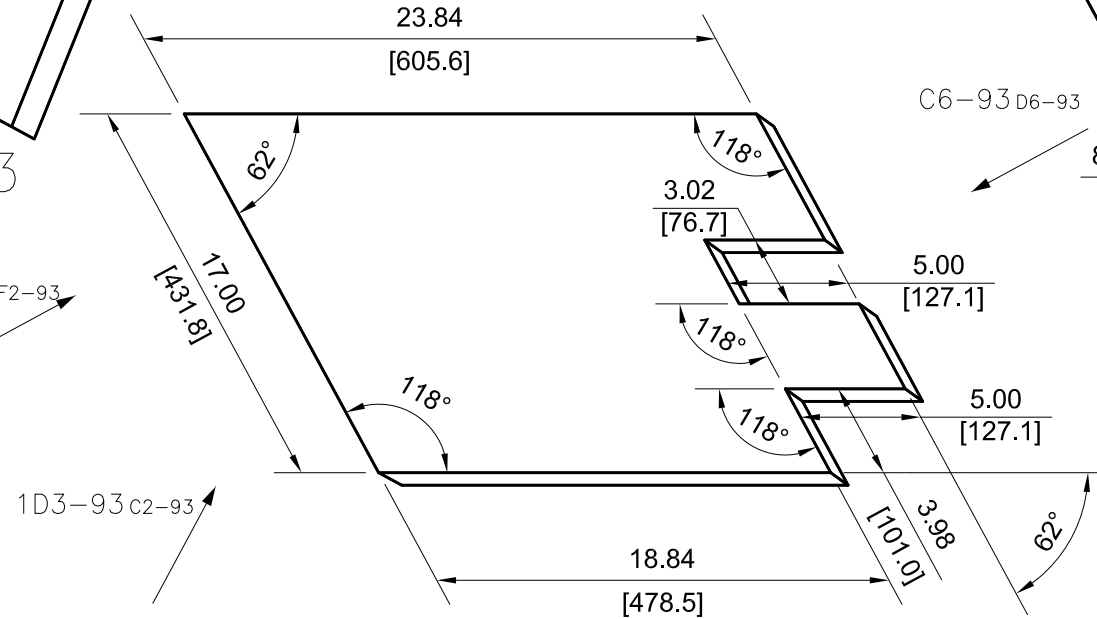

VIEW C6-93

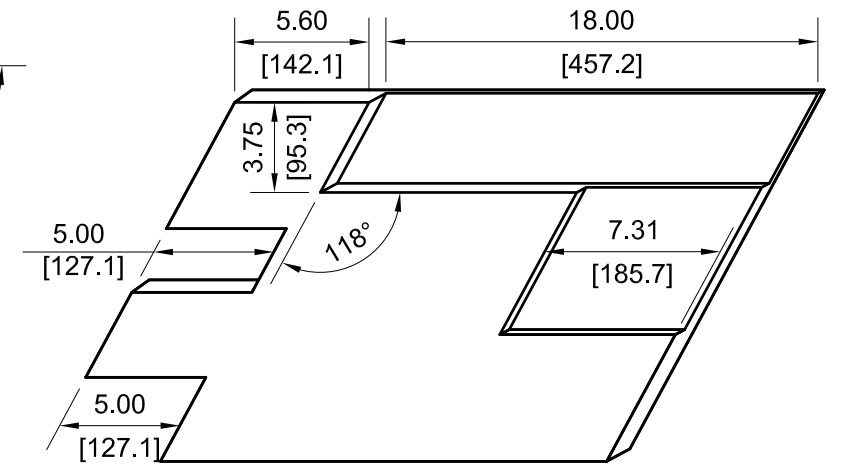

REAR VIEW RELATIVE TO VIEW D4-93



DRAWING NUMBER				
AES-D0008				
SIZE	SCALE	SHEET	OF	REVISION
A3	NONE	93	190	B

184

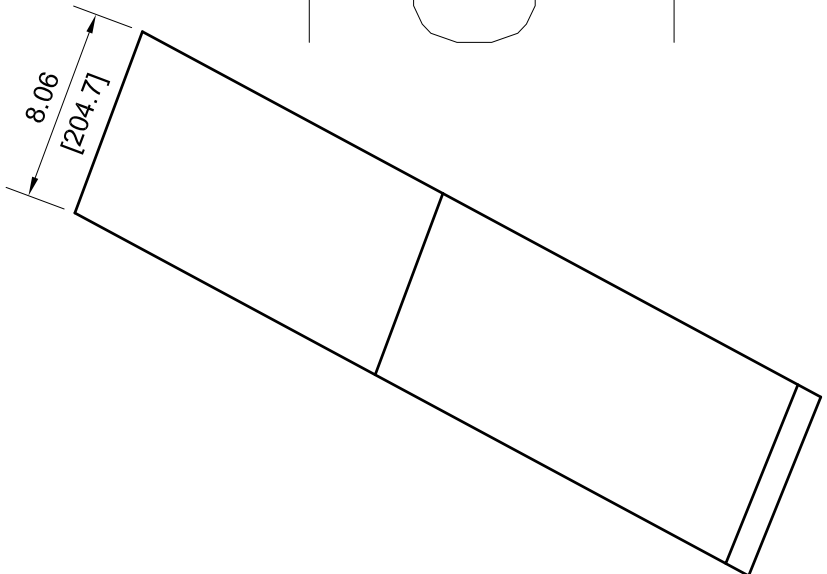

VIEW E4-94

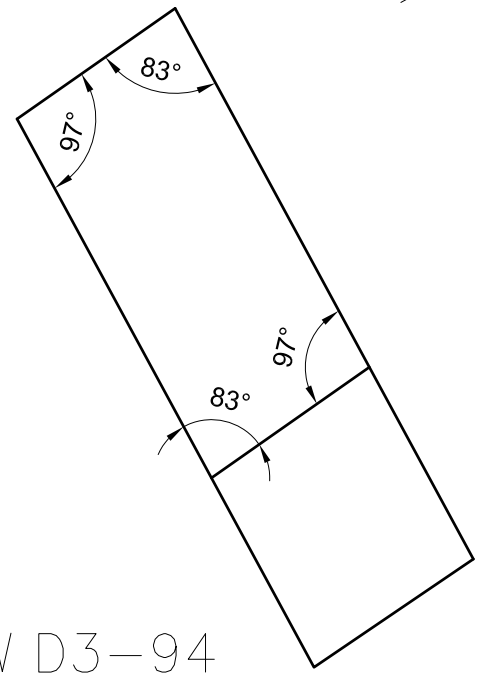
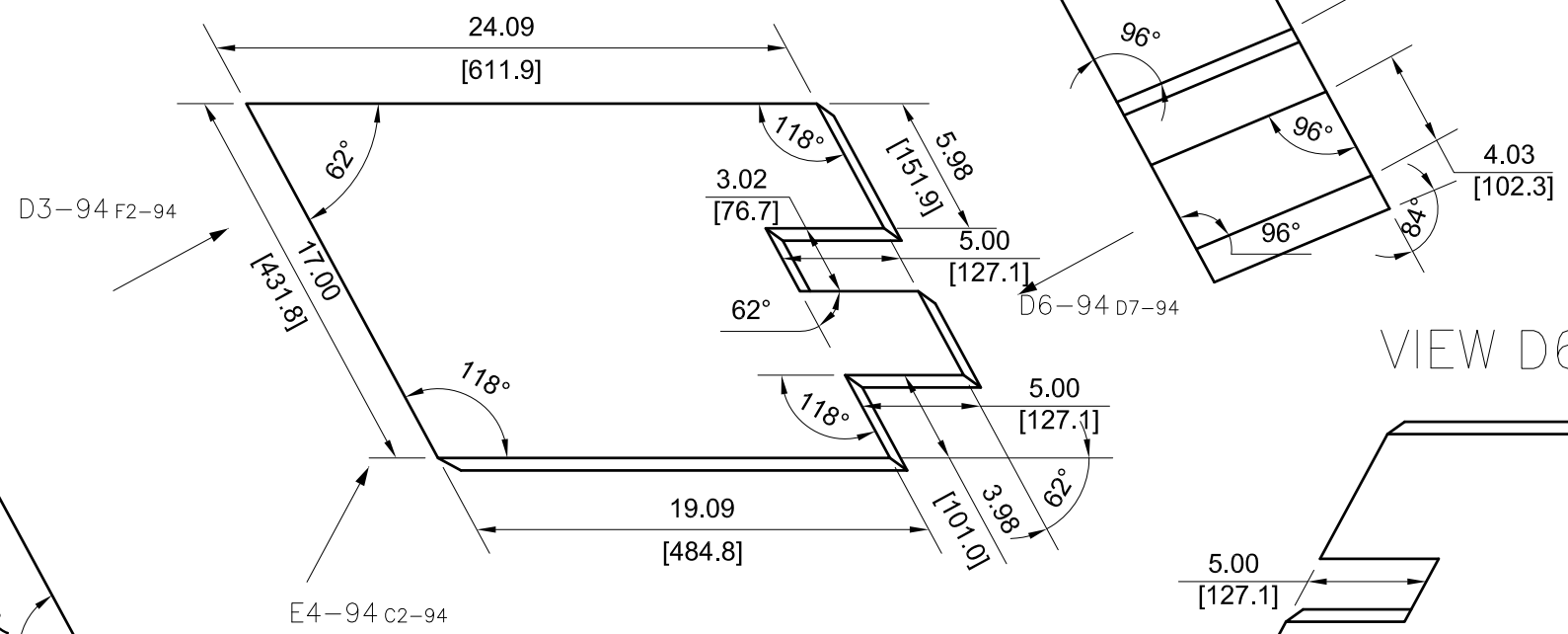
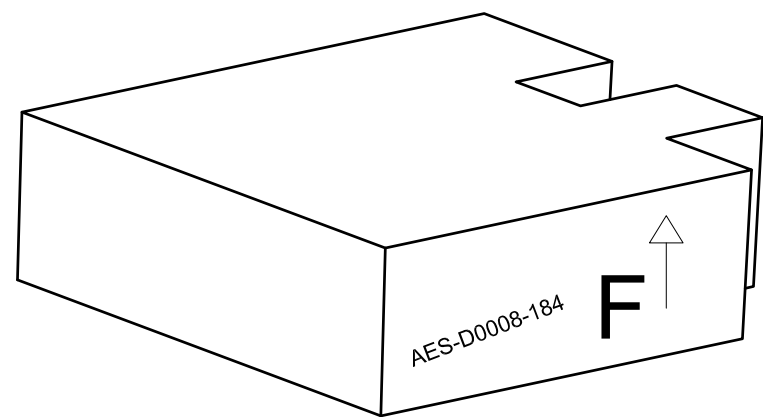

VIEW D3-94



VIEW D6-94

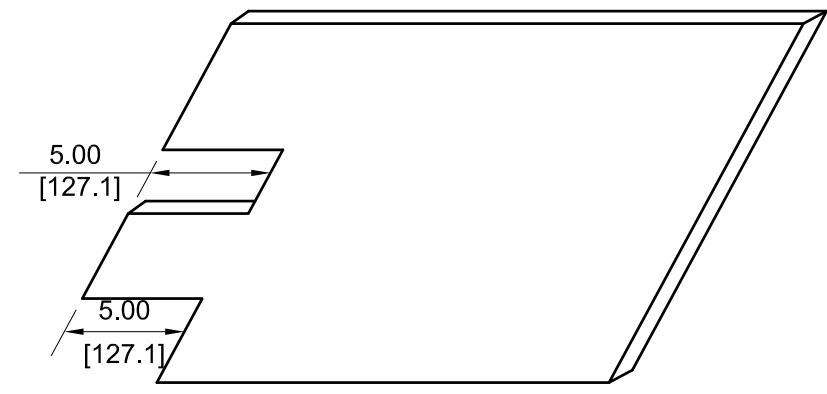

REAR VIEW RELATIVE TO VIEW D4-94



DRAWING NUMBER				
AES-D0008				
SIZE	SCALE	SHEET	OF	REVISION
A3	NONE	94	190	B

186

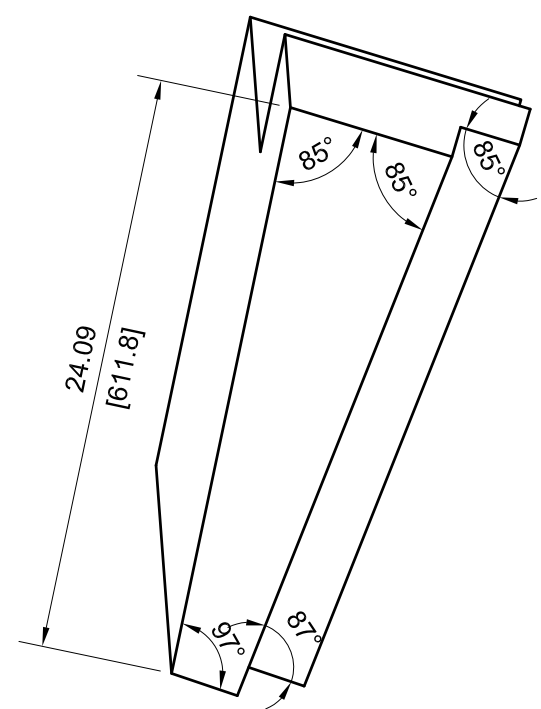

VIEW C3-95

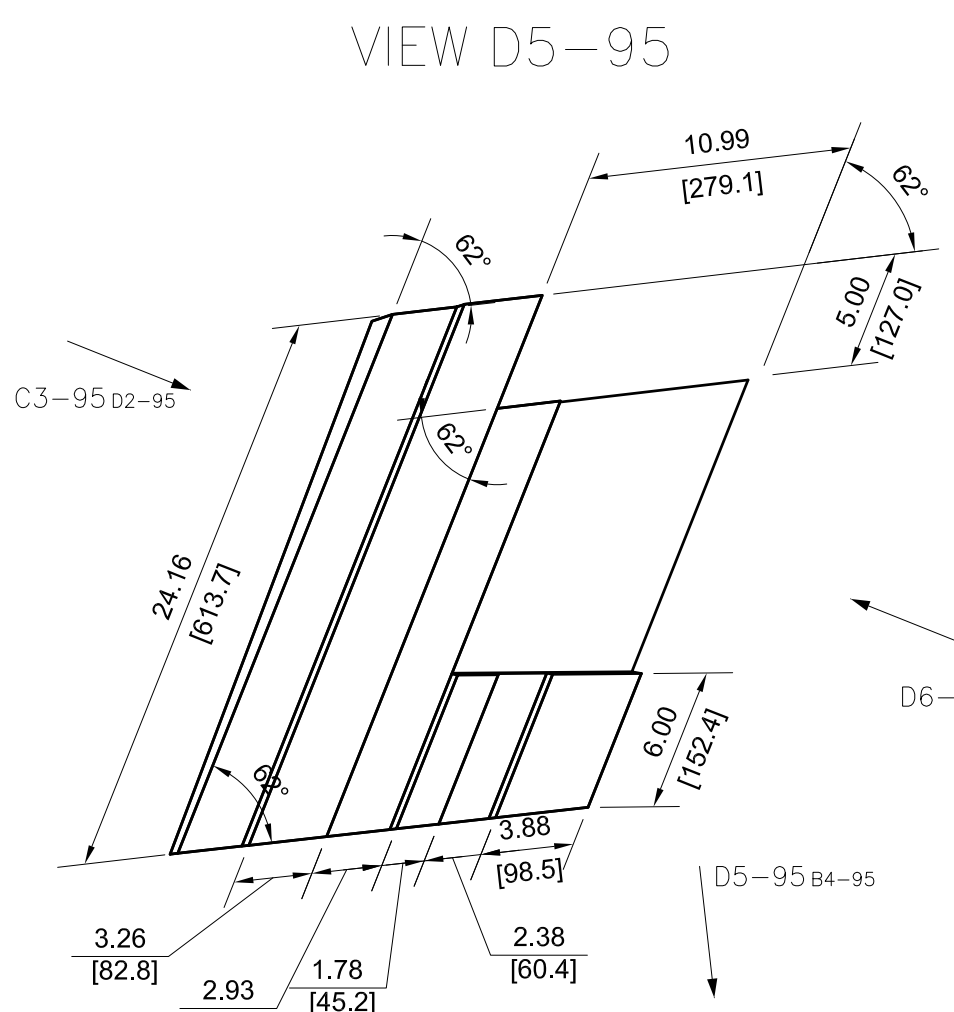

VIEW D5-95

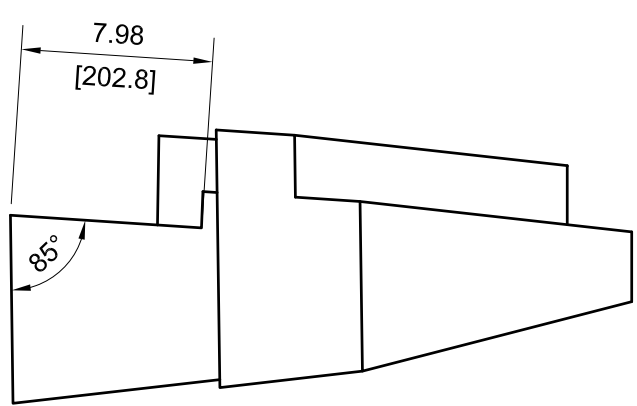
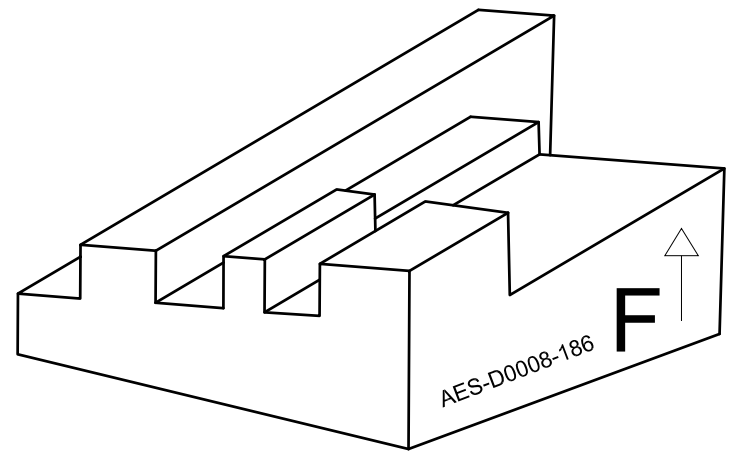

REAR VIEW RELATIVE TO VIEW D4-95

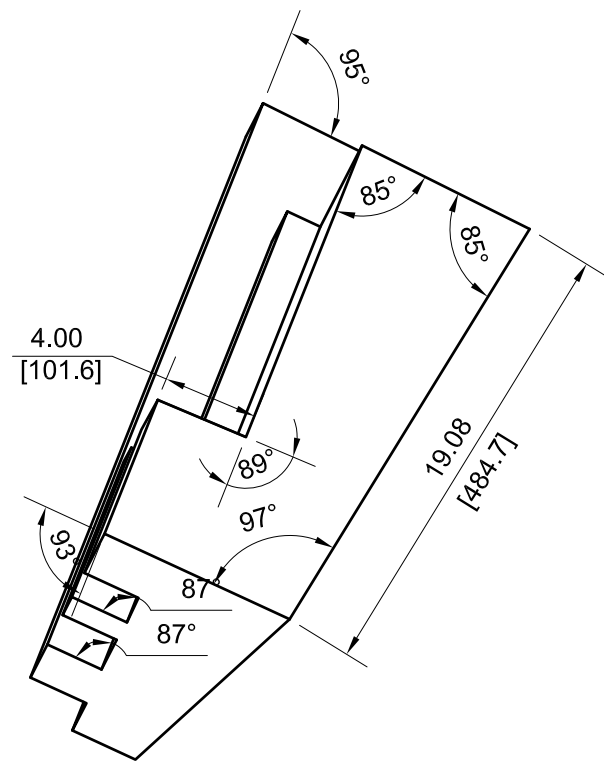
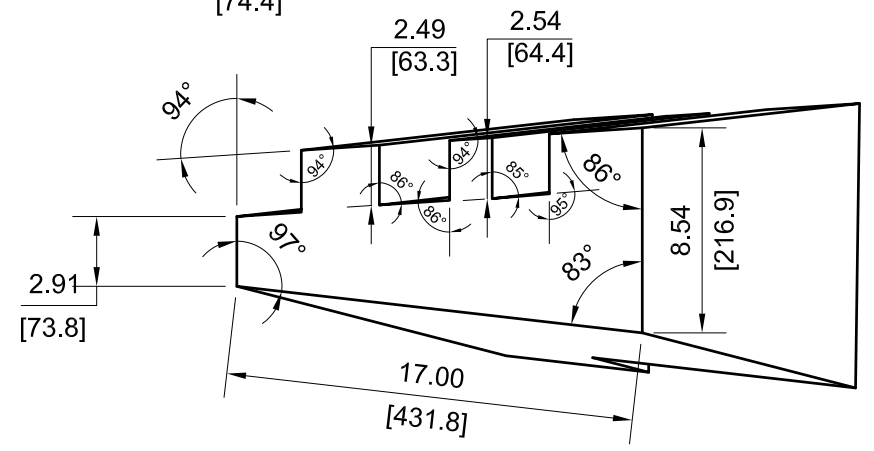

VIEW D6-95

		DRAWING NUMBER			
		AES-D0008			
SIZE	SCALE	SHEET	OF	REVISION	
A3	NONE	95	190	B	

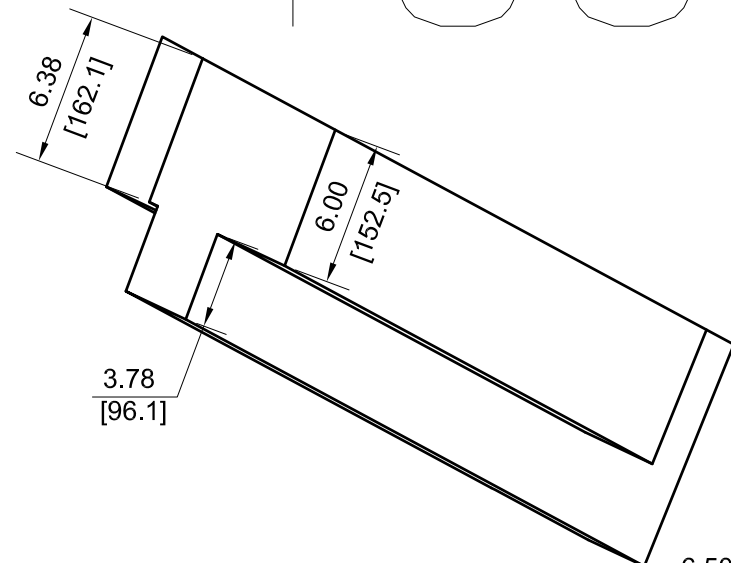
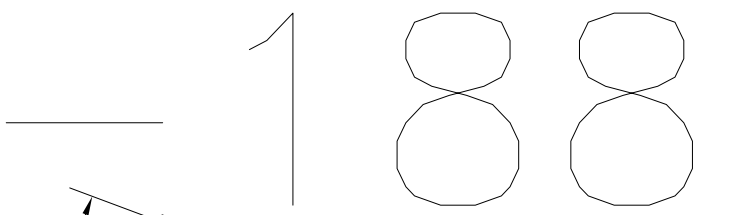

VIEW E3-96

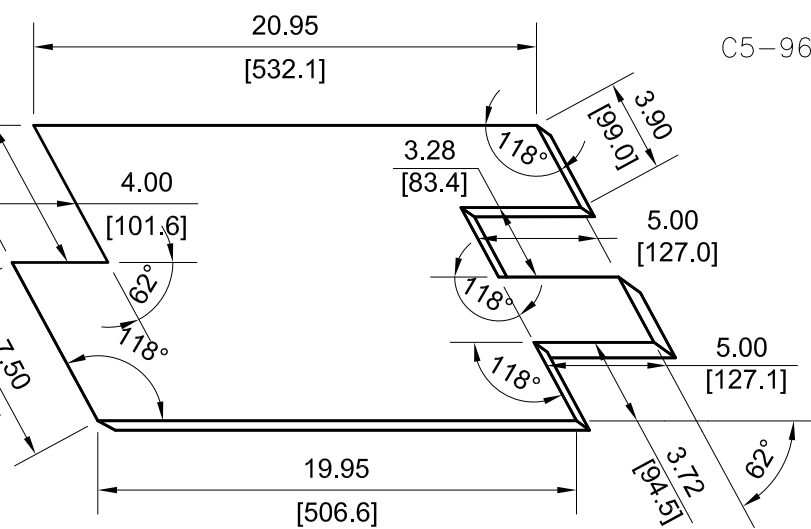
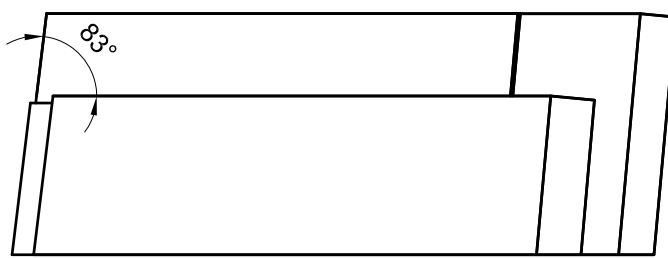

E3-96 C1-96

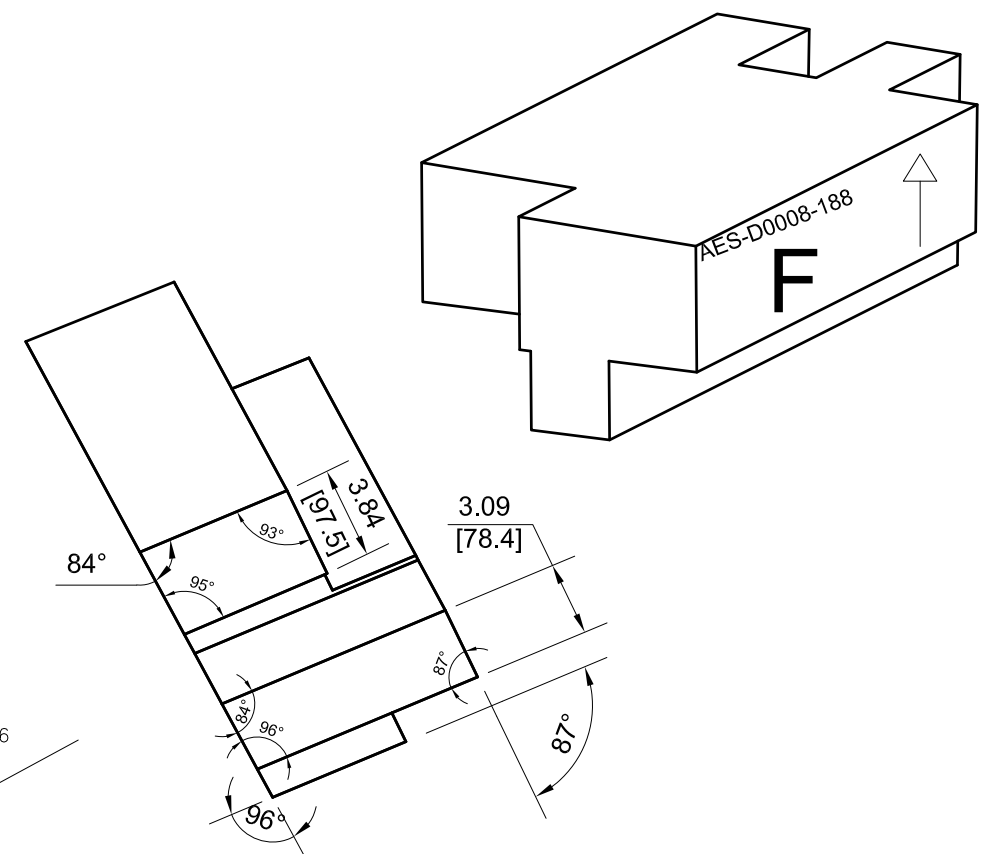
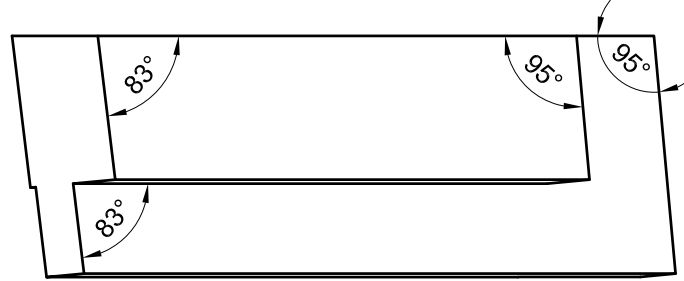

VIEW C5-96

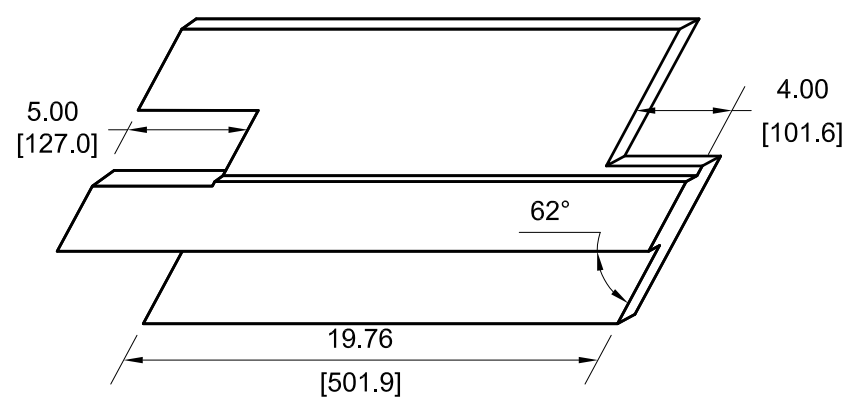
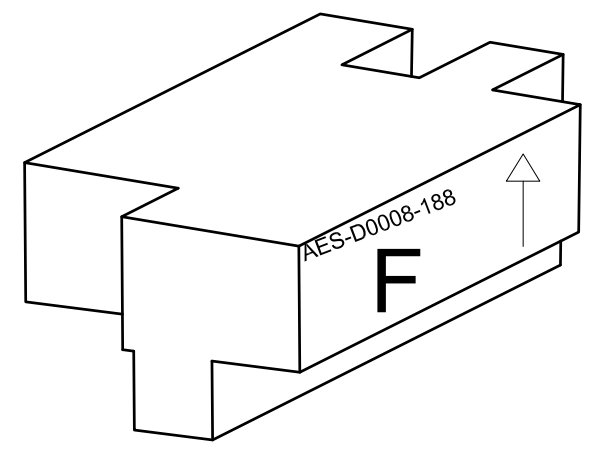

REAR VIEW RELATIVE TO VIEW D4-96

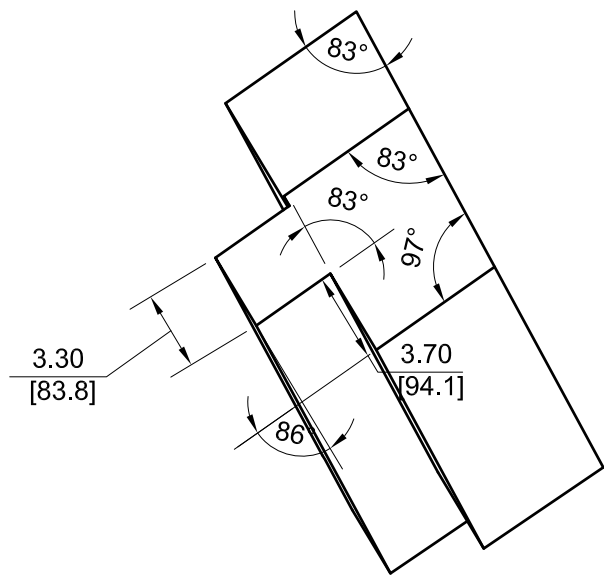

VIEW D2-96

	DRAWING NUMBER				
	AES-D0008				
SIZE	SCALE	SHEET	OF	REVISION	
A3	NONE	96	190	B	

190

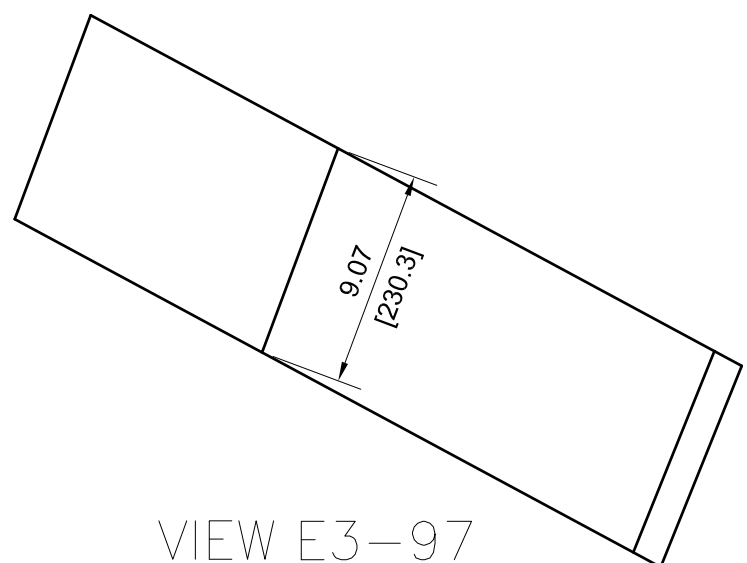
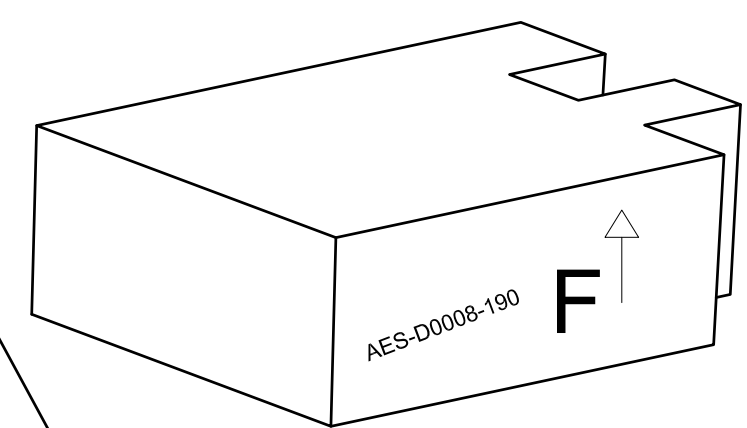

VIEW E3-97

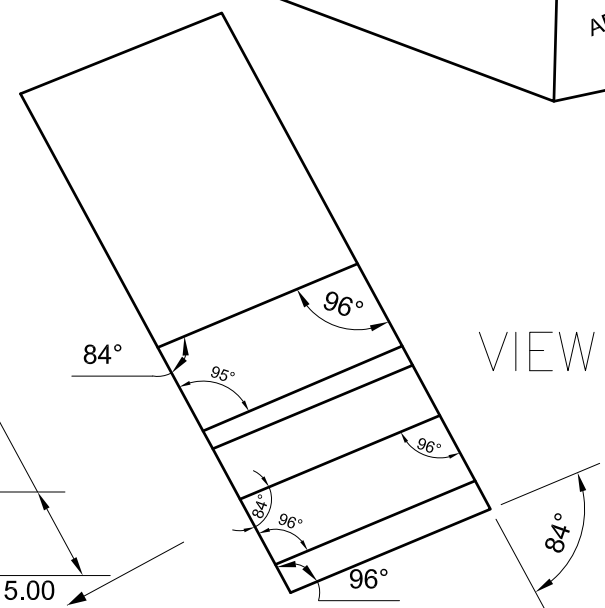
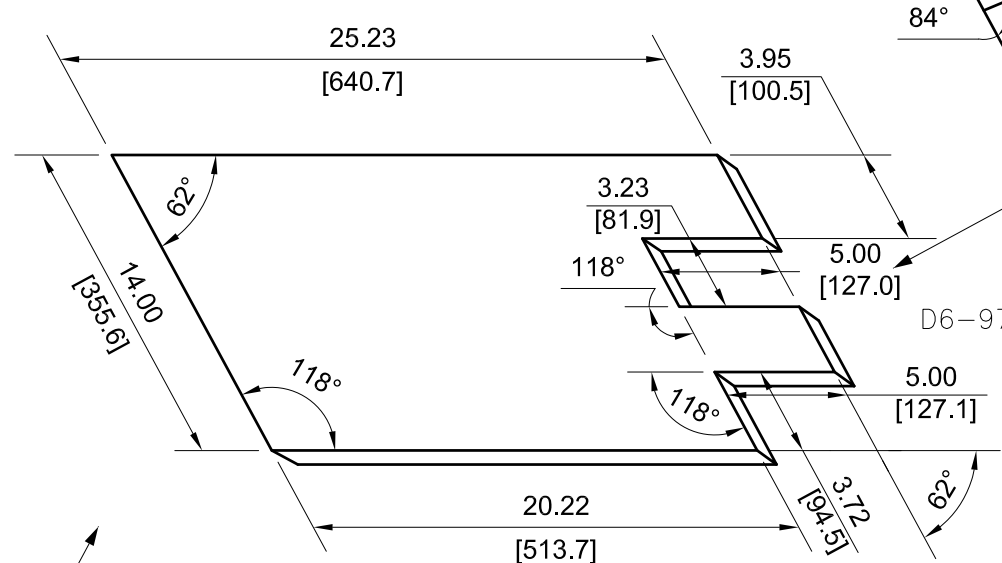

VIEW D6-97

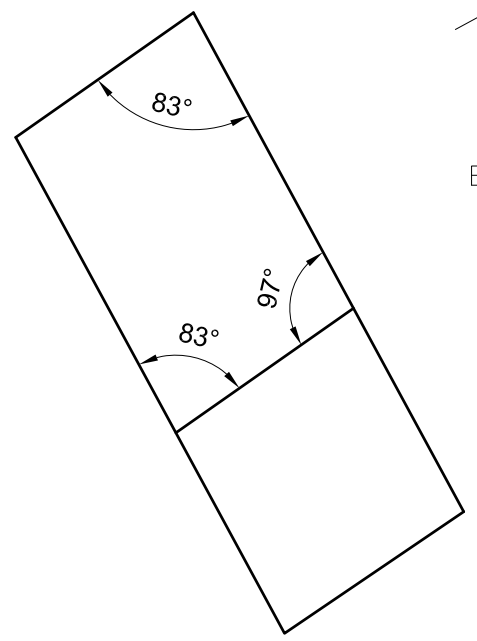

VIEW D2-97

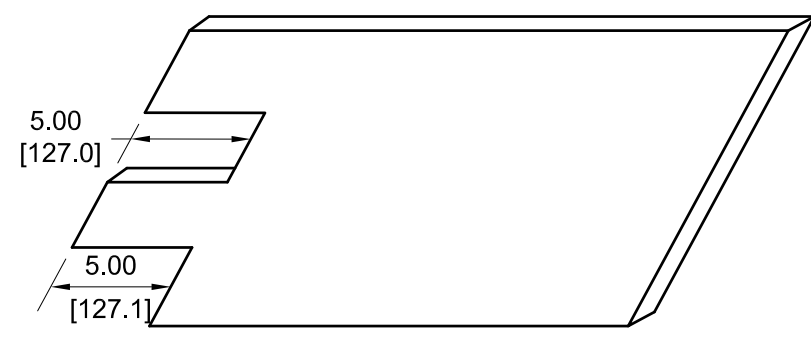
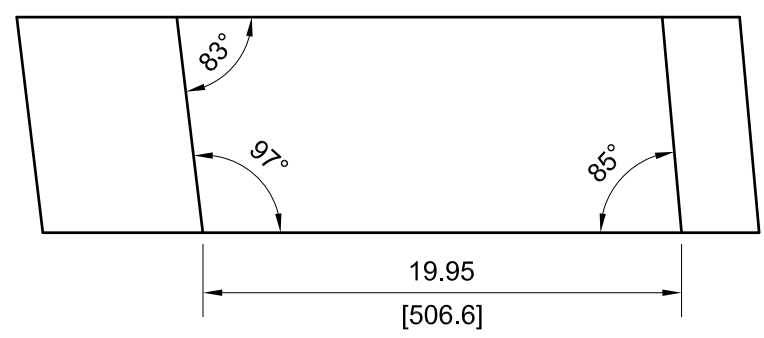

REAR VIEW RELATIVE TO VIEW D4-97

D2-97 F2-97

E3-97 C2-97

D6-97 C7-97



DRAWING NUMBER				
AES-D0008				
SIZE	SCALE	SHEET	OF	REVISION
A3	NONE	97	190	B

192

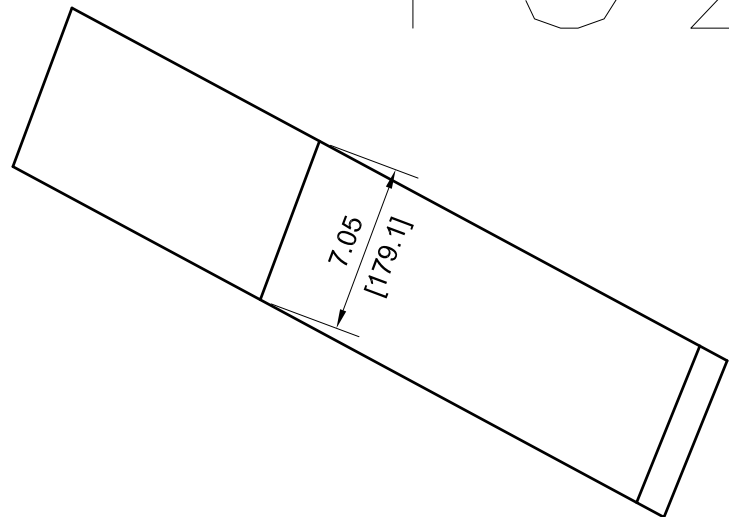

VIEW E3-98

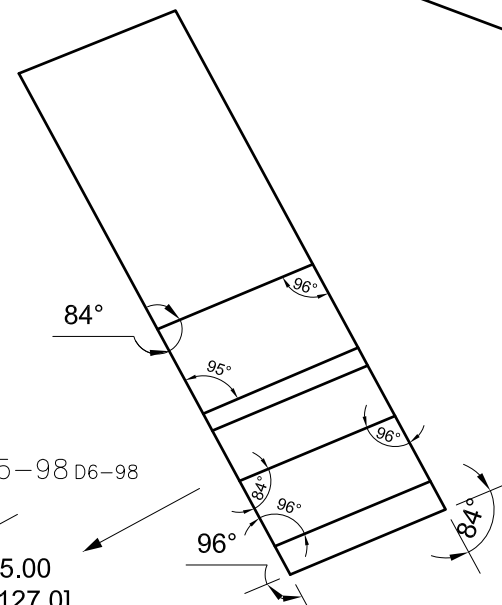
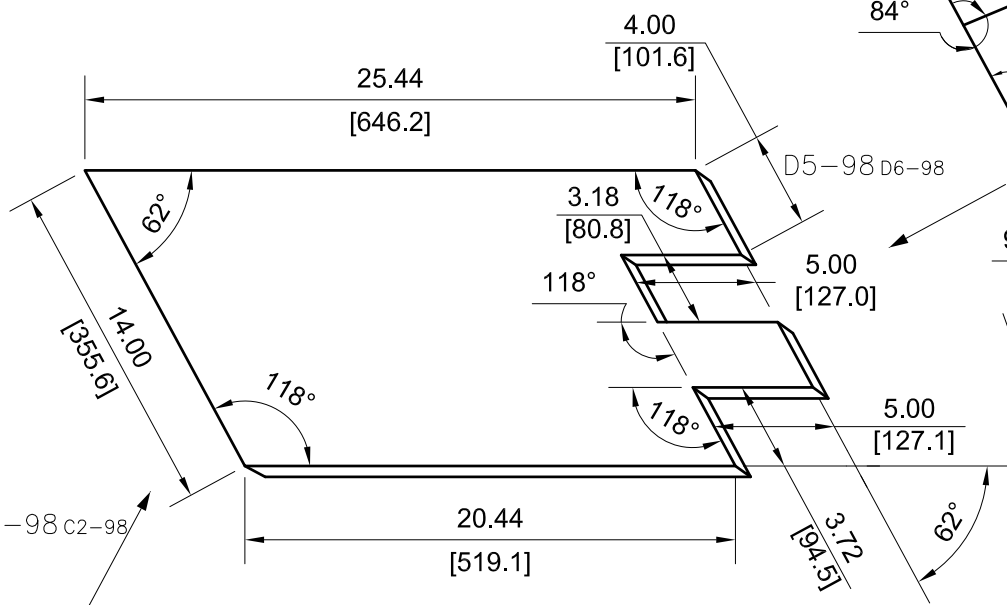
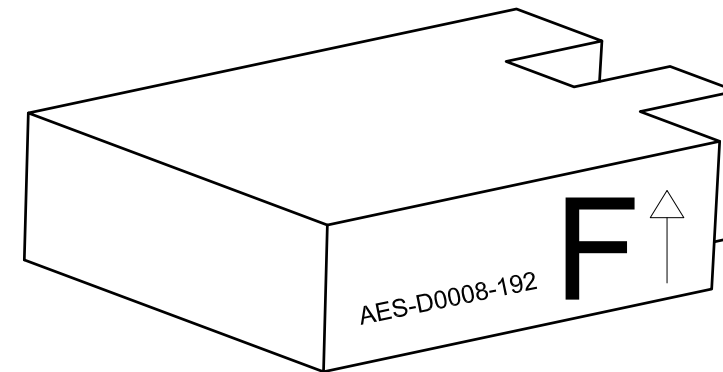

VIEW D5-98

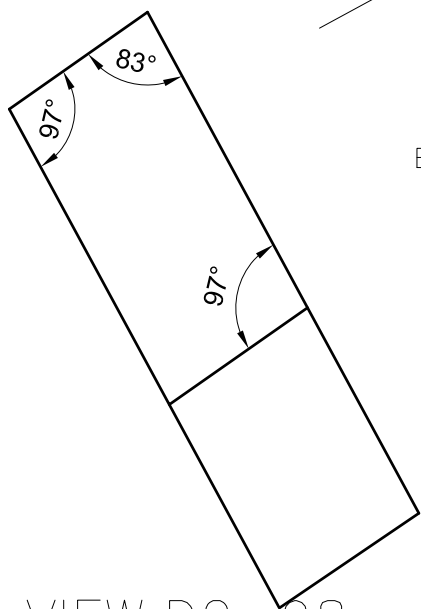

VIEW D2-98

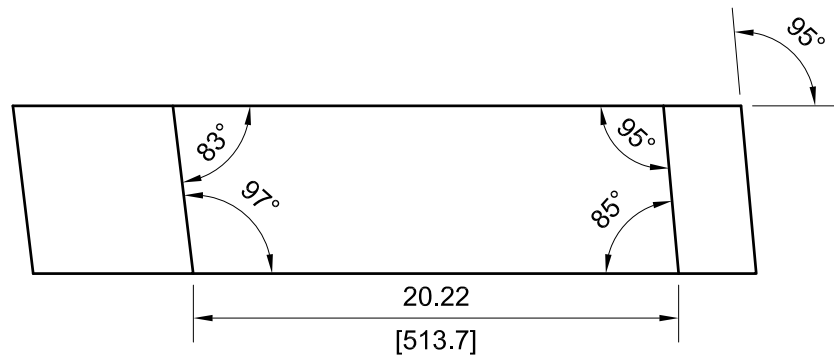

REAR VIEW RELATIVE TO VIEW D4-98



DRAWING NUMBER				
AES-D0008				
SIZE	SCALE	SHEET	OF	REVISION
A3	NONE	98	190	B

194

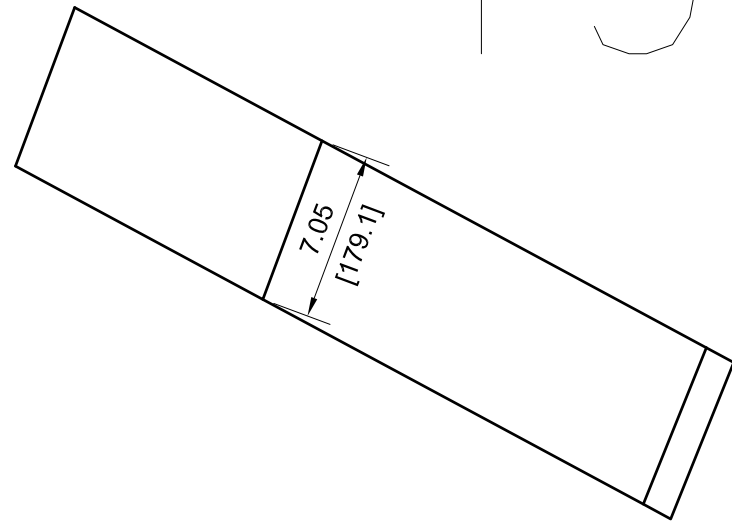

VIEW E3-99

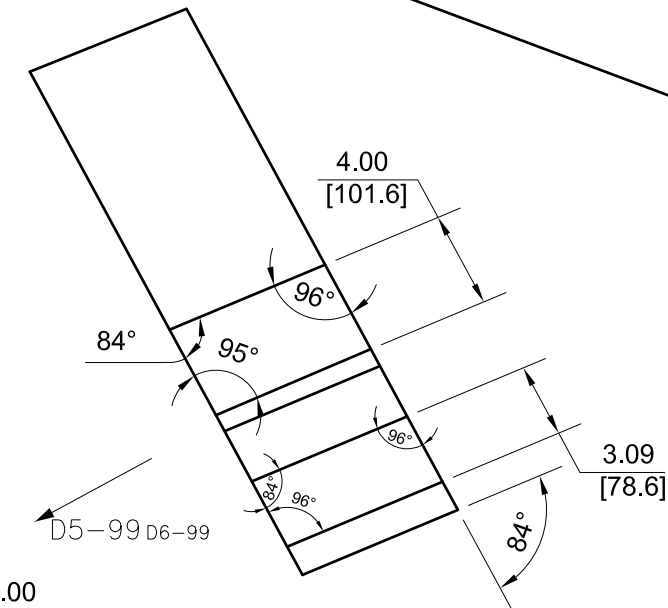
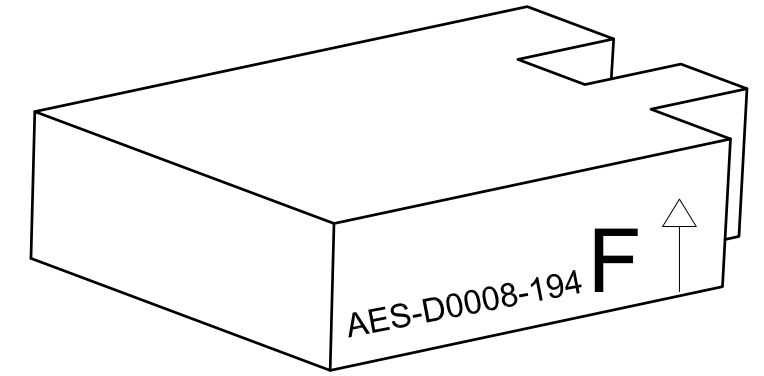

VIEW D5-99

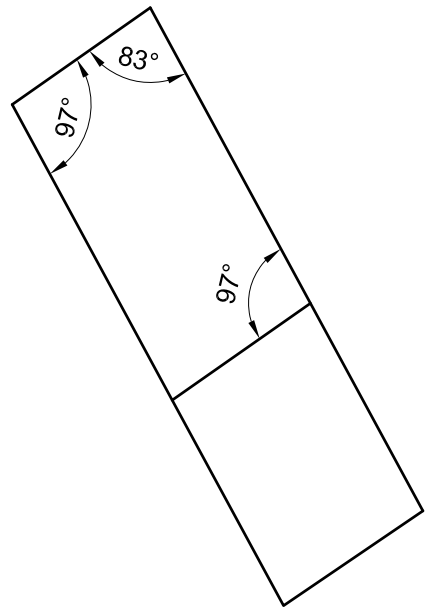
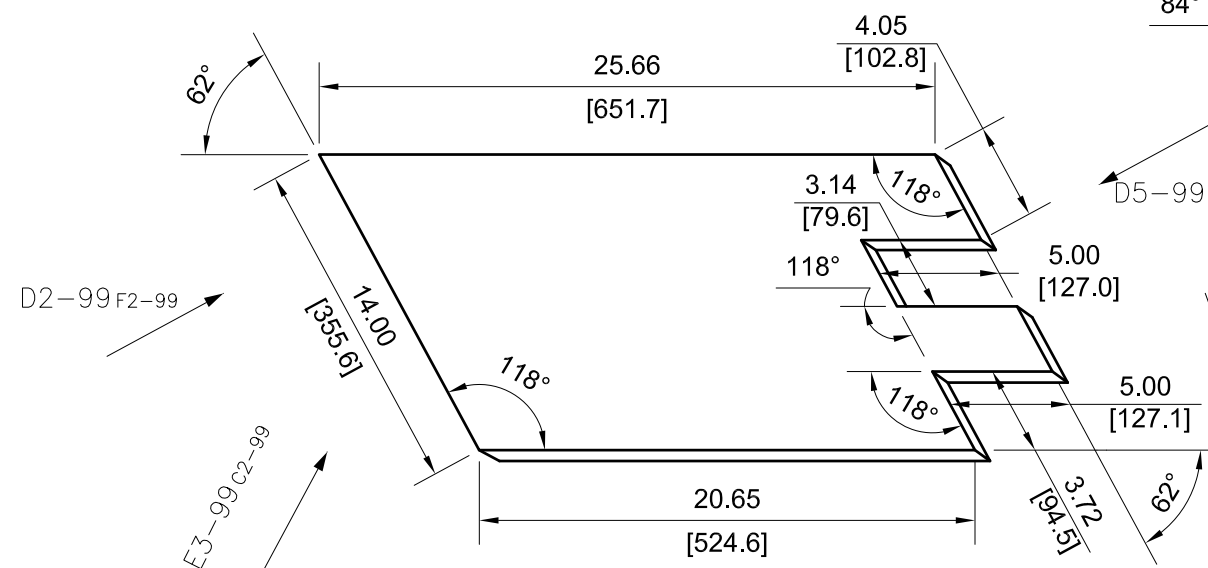

VIEW D2-99

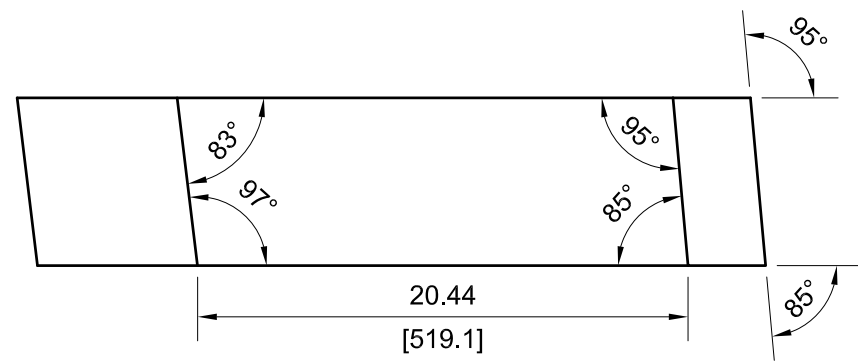

REAR VIEW RELATIVE TO VIEW D4-99



DRAWING NUMBER				
AES-D0008				
SIZE	SCALE	SHEET	OF	REVISION
A3	NONE	99	190	B

196

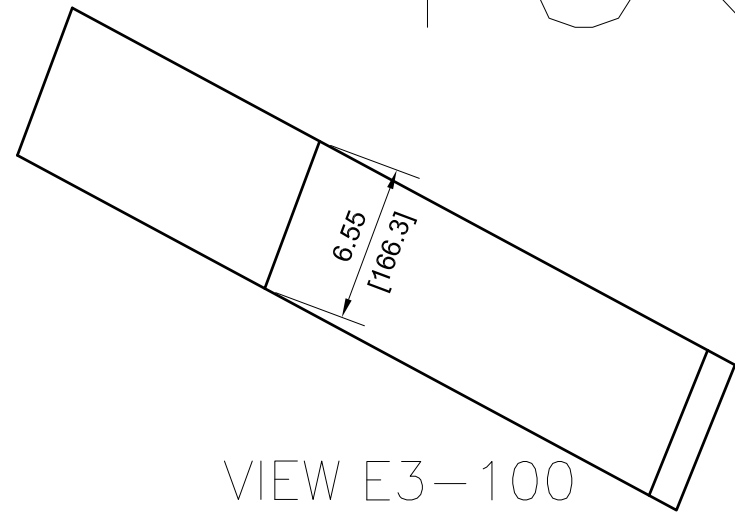

VIEW E3-100

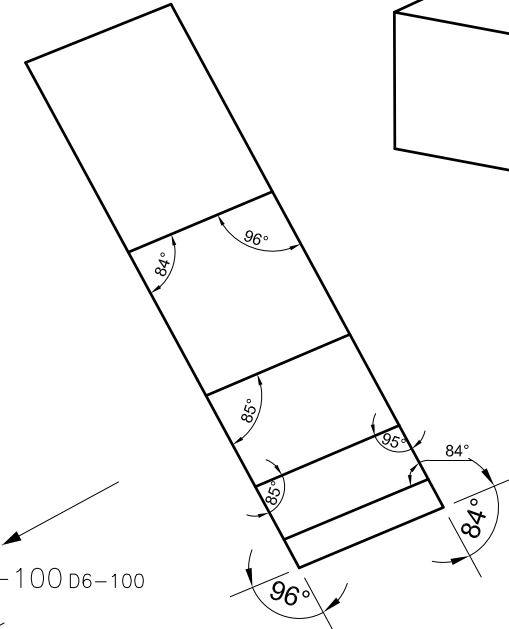
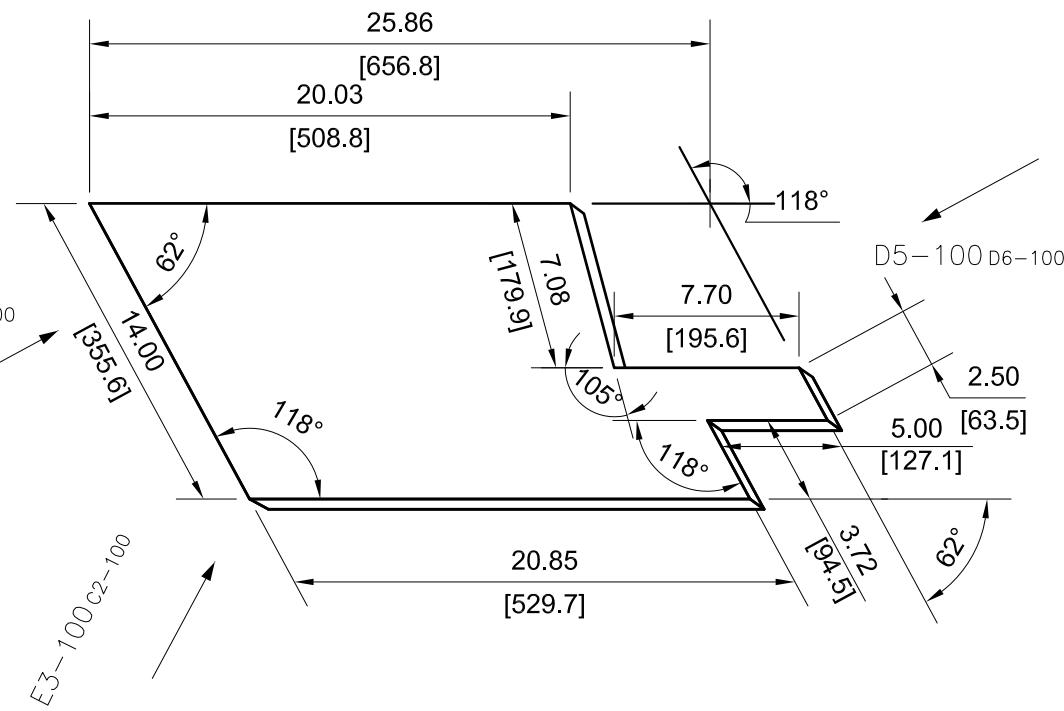
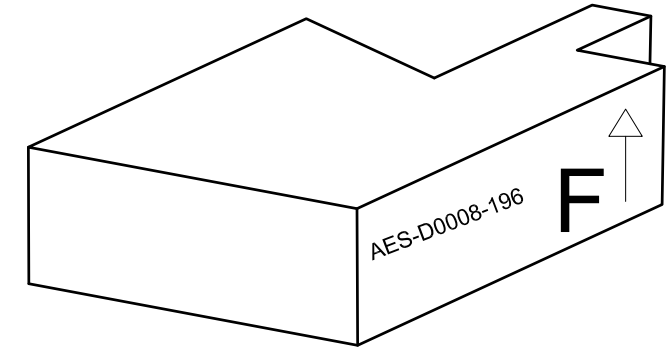
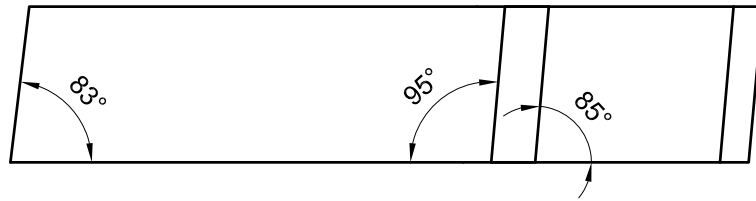

VIEW D5-100

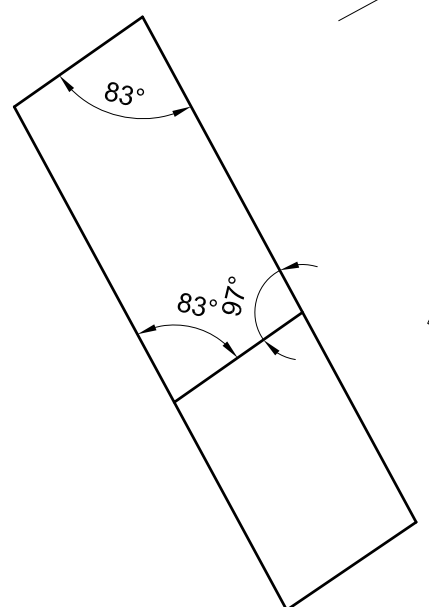

VIEW D2-100

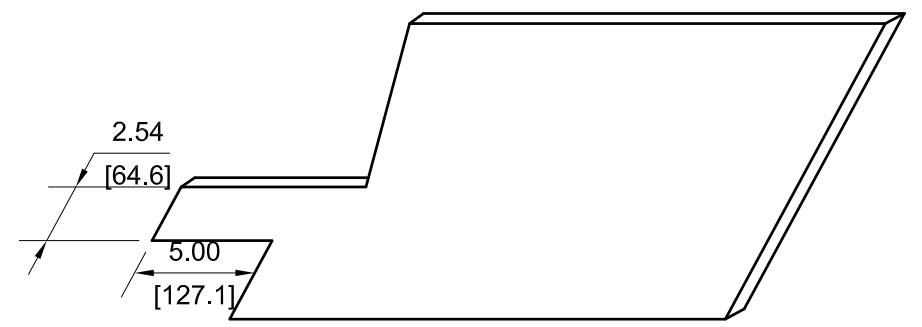
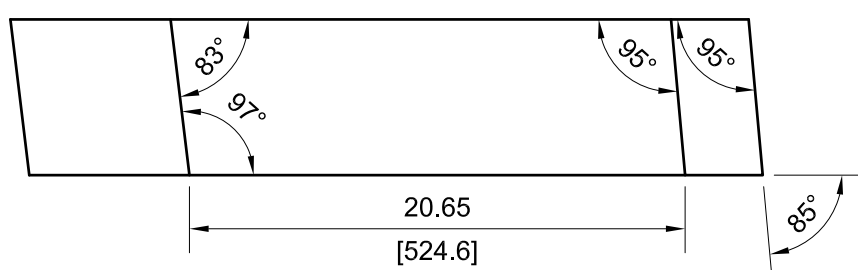

REAR VIEW RELATIVE TO VIEW D4-100



DRAWING NUMBER				
AES-D0008				
SIZE	SCALE	SHEET	OF	REVISION
A3	NONE	100	190	B

198

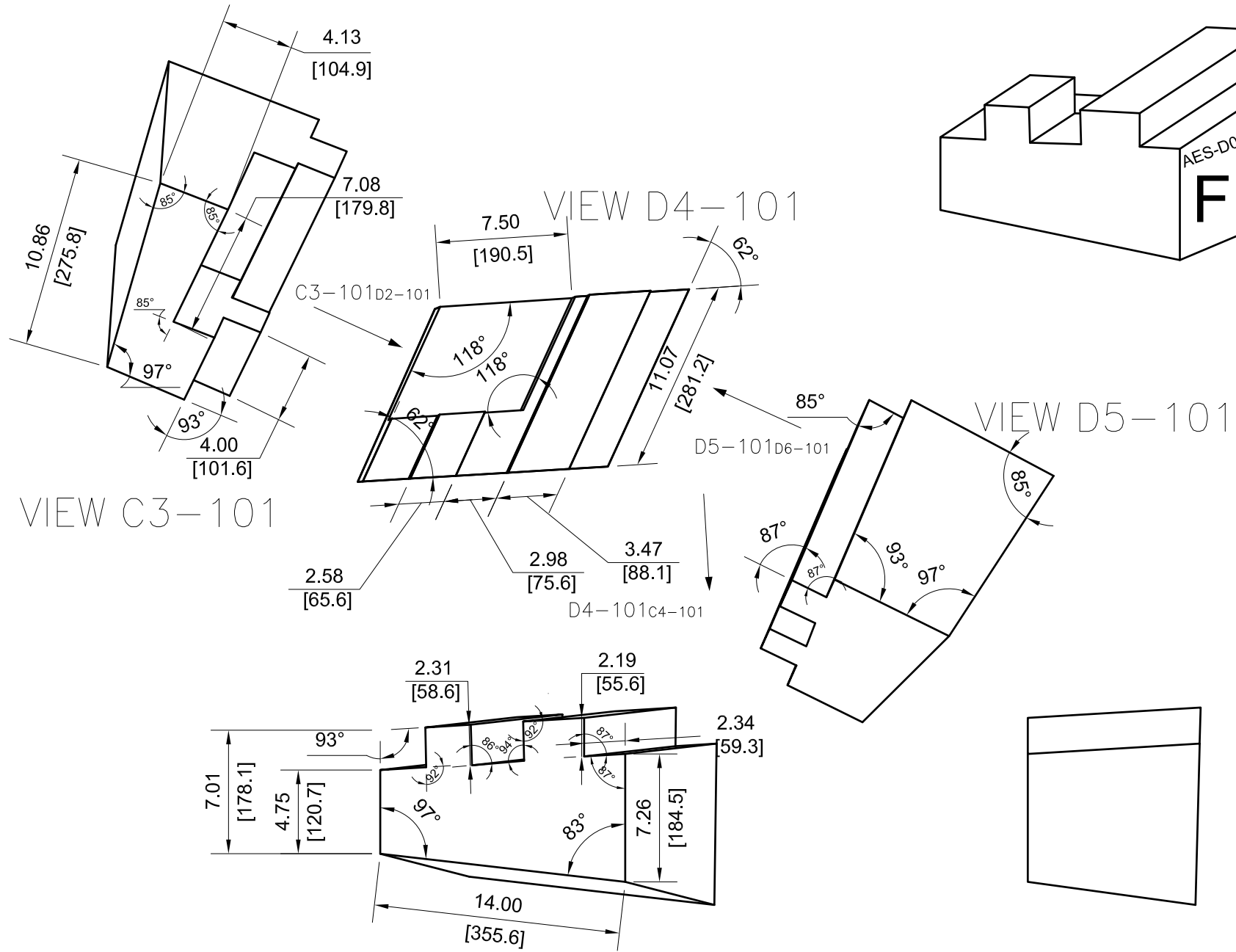

DRAWING NUMBER				
AES-D0008				
SIZE	SCALE	SHEET	OF	REVISION
A3	NONE	101	190	B

— 200

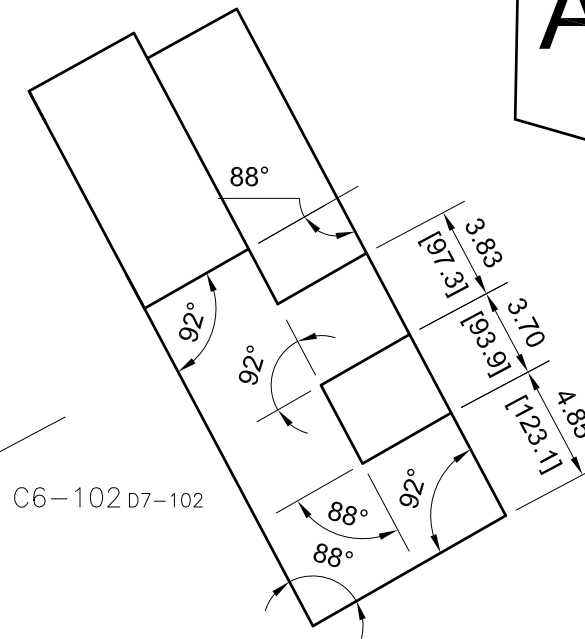
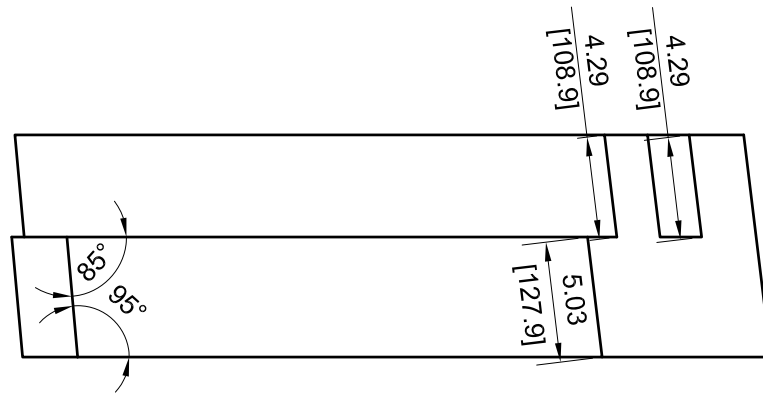
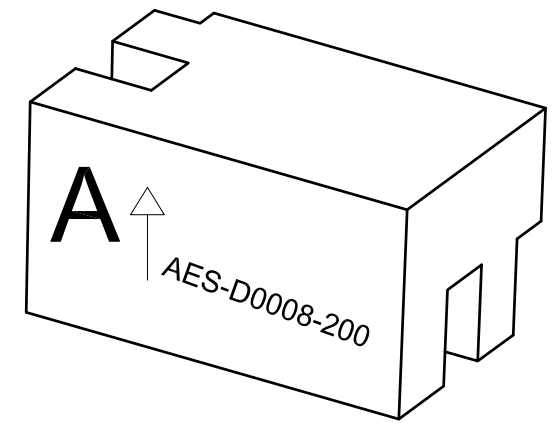

VIEW C6-102

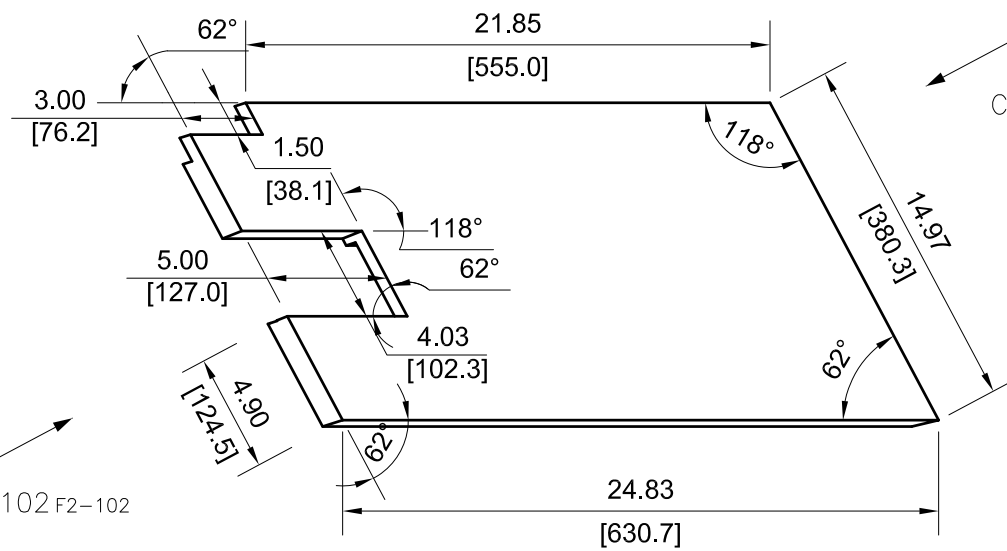

C6-102 D7-102

D3-102 F2-102

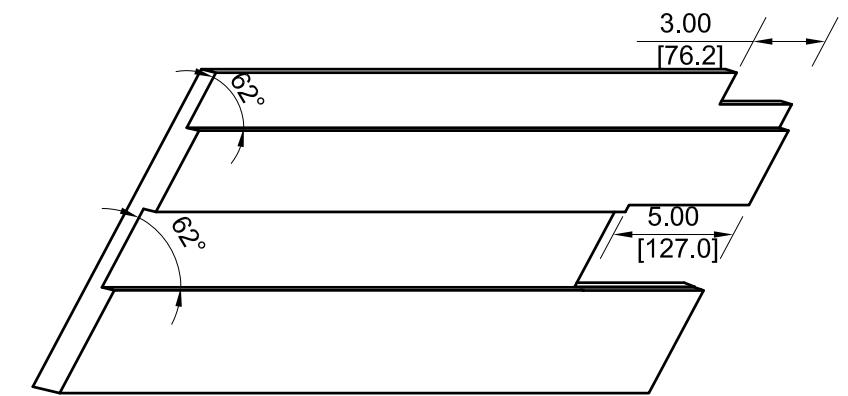

REAR VIEW RELATIVE TO VIEW D4-102

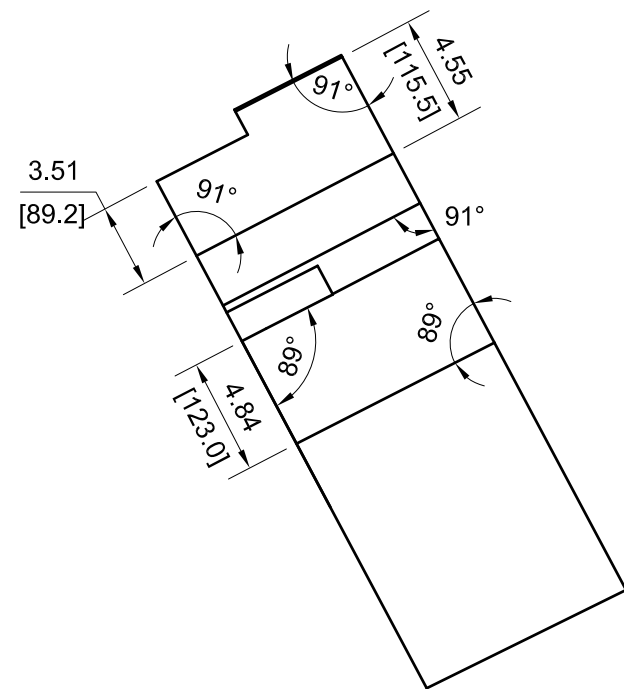
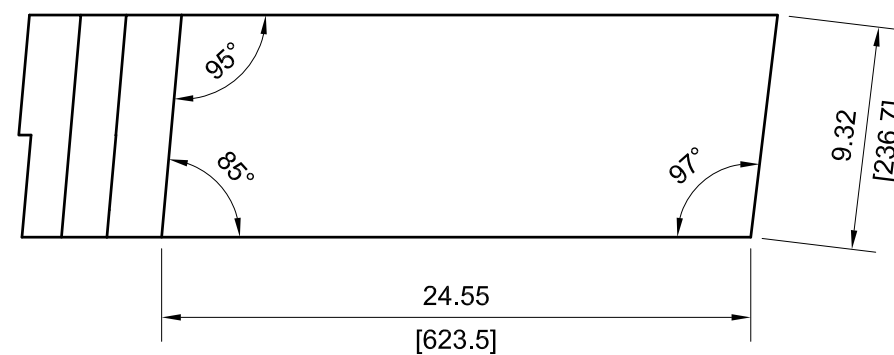

VIEW D3-102



DRAWING NUMBER					AES-D0008	
SIZE	SCALE	SHEET	OF	REVISION		
A3	NONE	102	190	B		

— 202

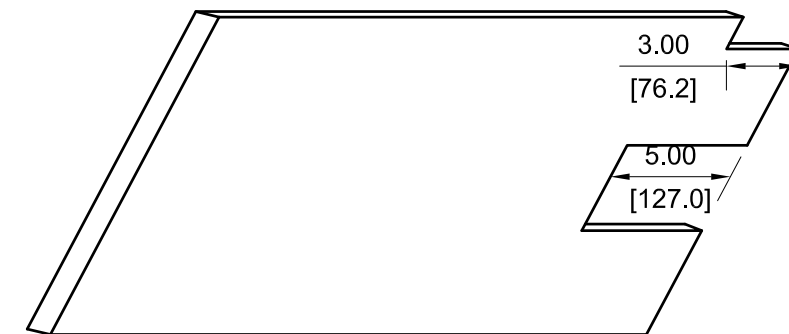
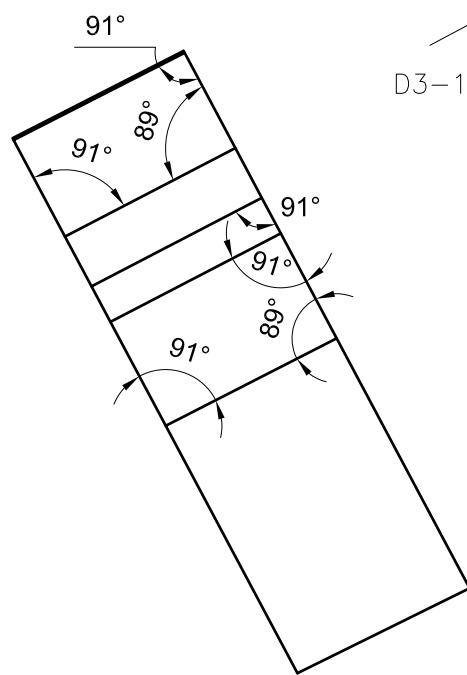
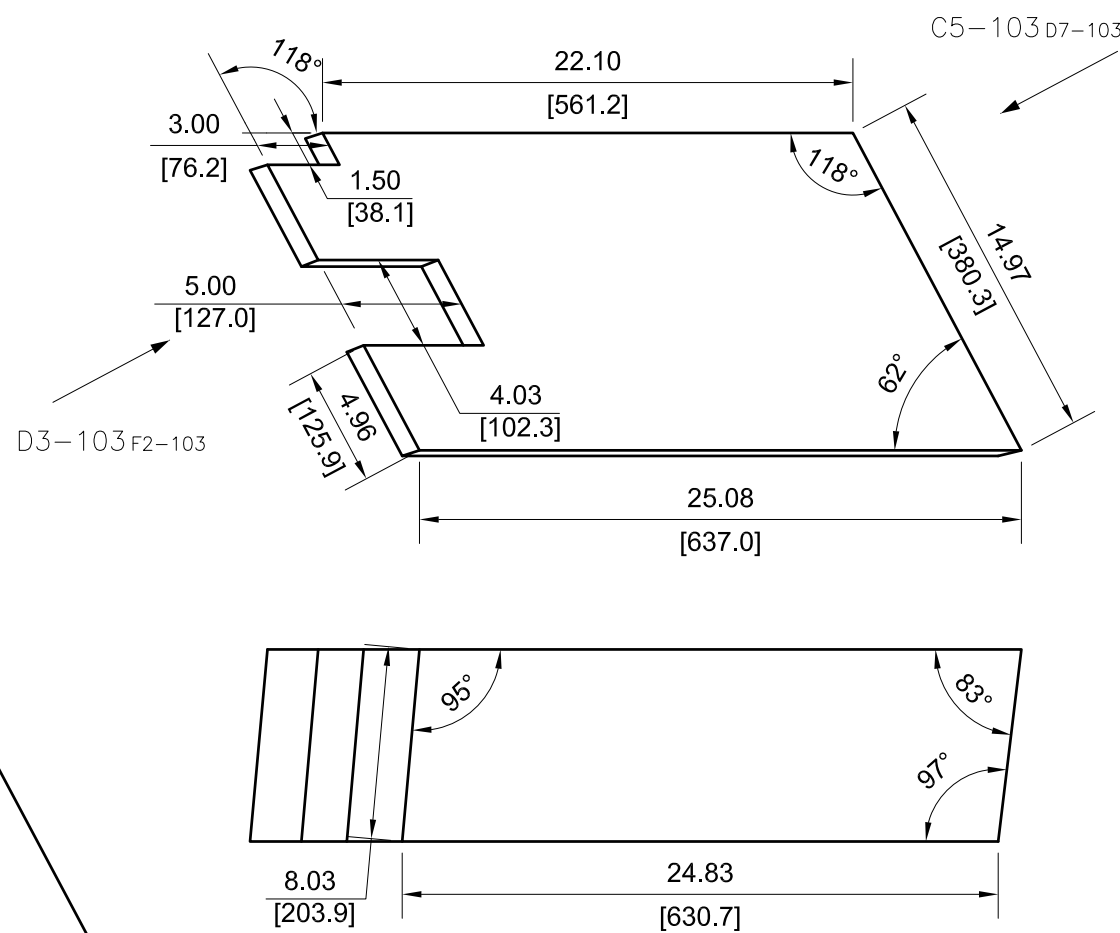
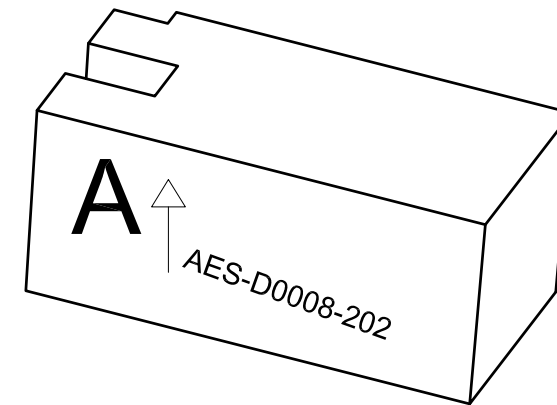

VIEW D3-103



DRAWING NUMBER					AES-D0008	
SIZE	SCALE	SHEET	OF	REVISION		
A3	NONE	103	190	B		

— 204

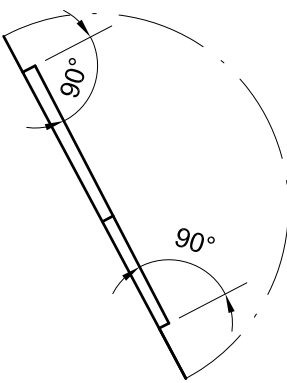
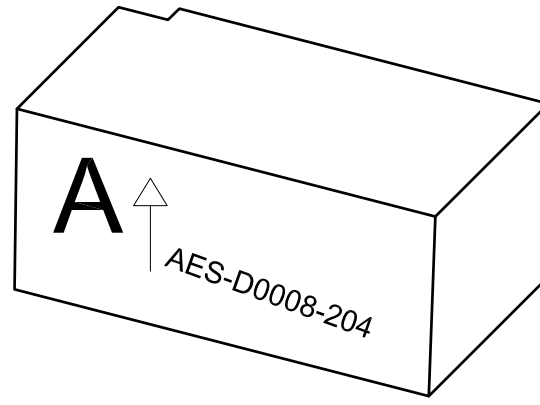

DETAIL E1-104

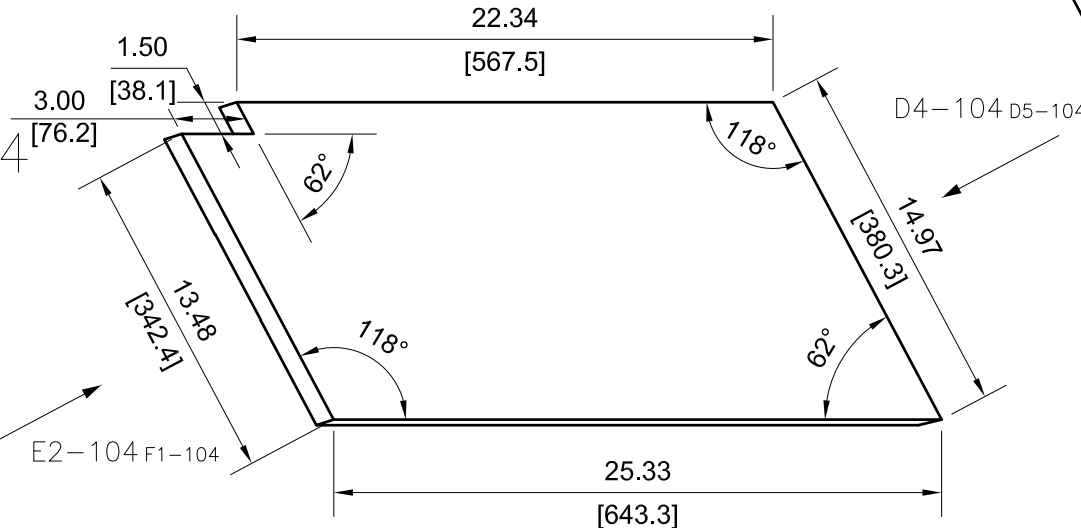

VIEW D4-104

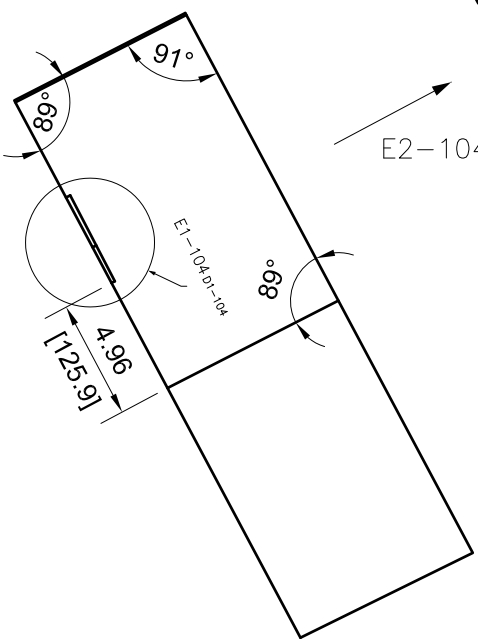
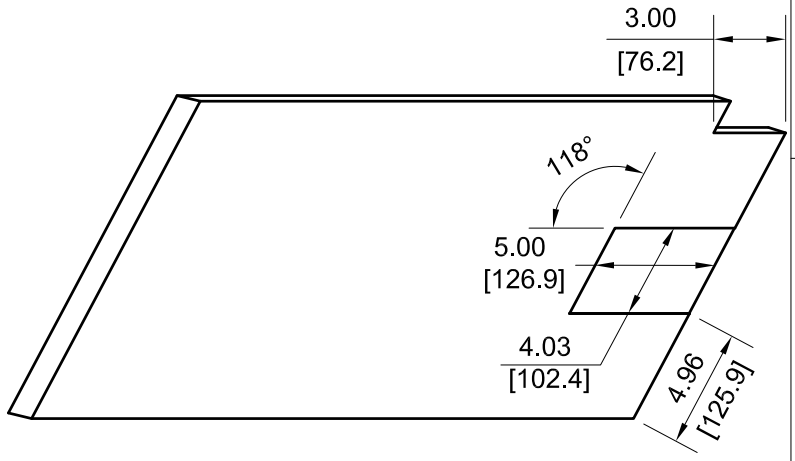
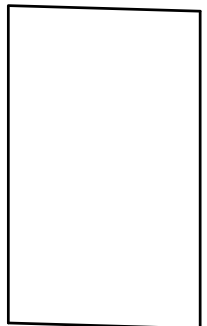

VIEW E2-104

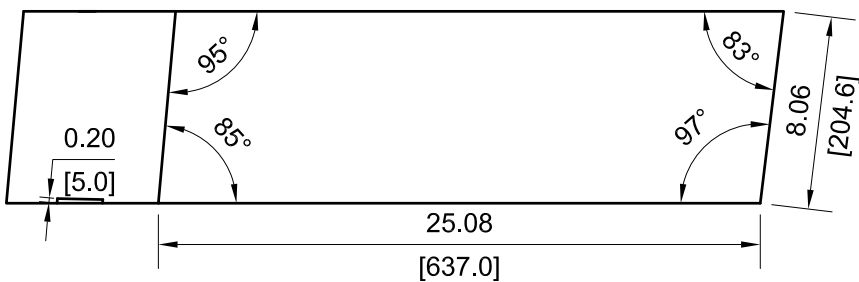

		DRAWING NUMBER			
		AES-D0008			
SIZE	SCALE	SHEET	OF	REVISION	
A3	NONE	104	190	B	

— 2006

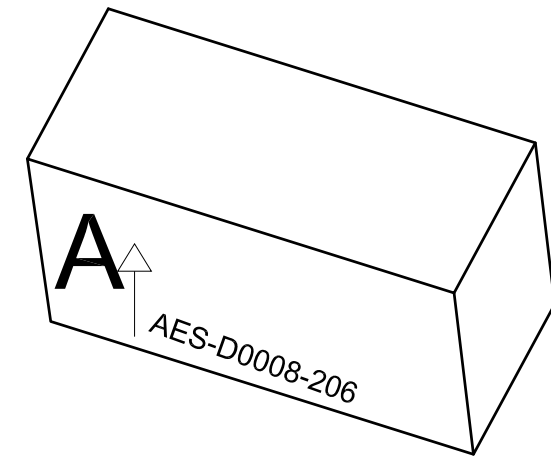

C5-105 D6-105

VIEW C5-105

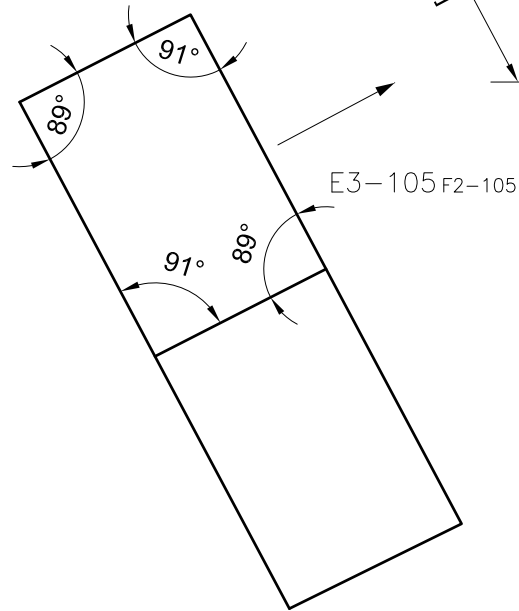
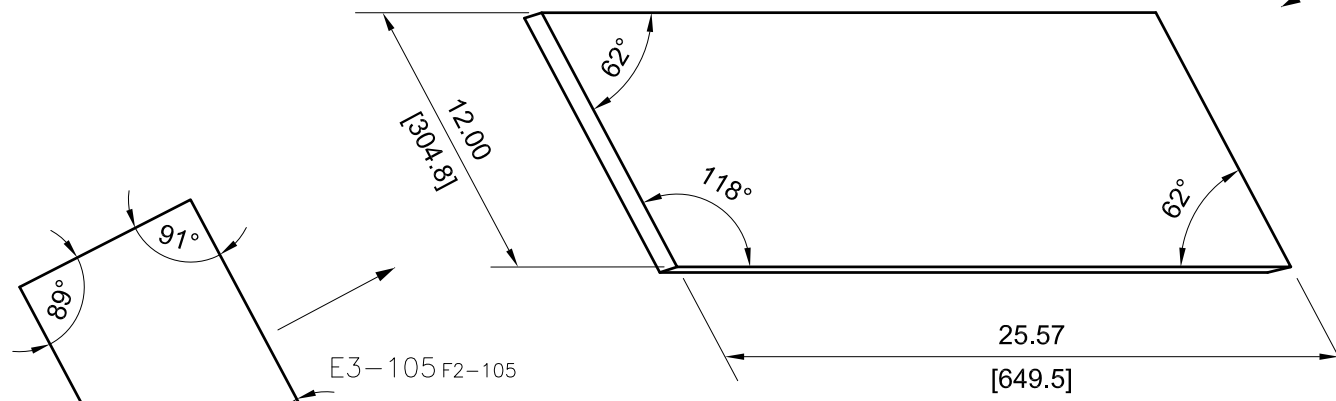

E3-105 F2-105

VIEW E3-105

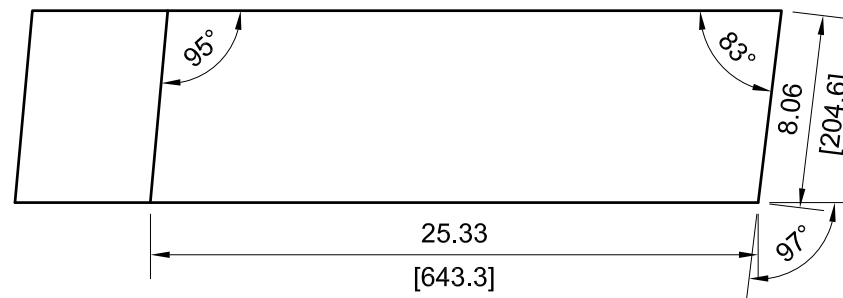

UP
1

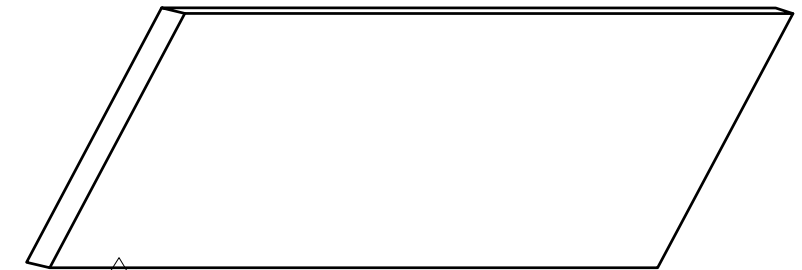

REAR VIEW RELATIVE TO VIEW D4-105



DRAWING NUMBER					AES-D0008	
SIZE	SCALE	SHEET	OF	REVISION		
A3	NONE	105	190	B		

— 208

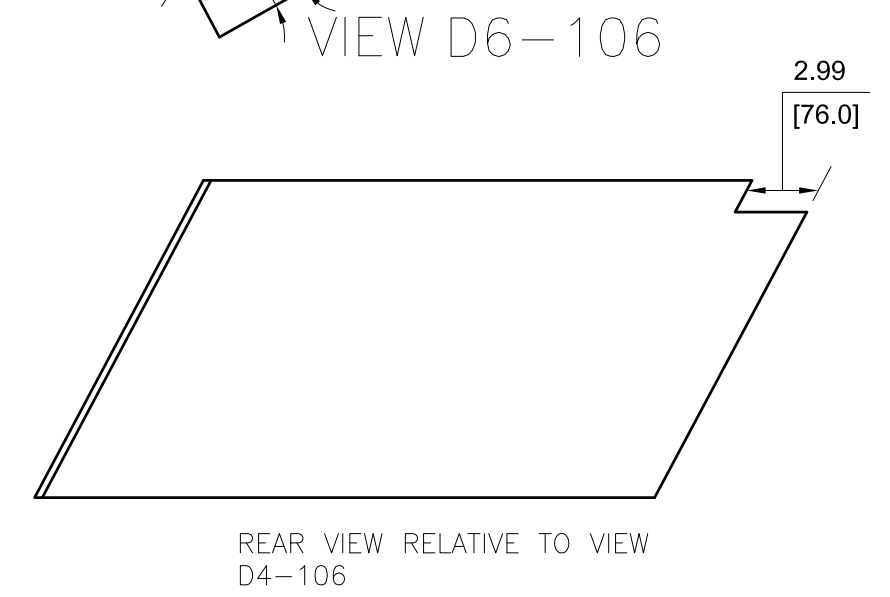
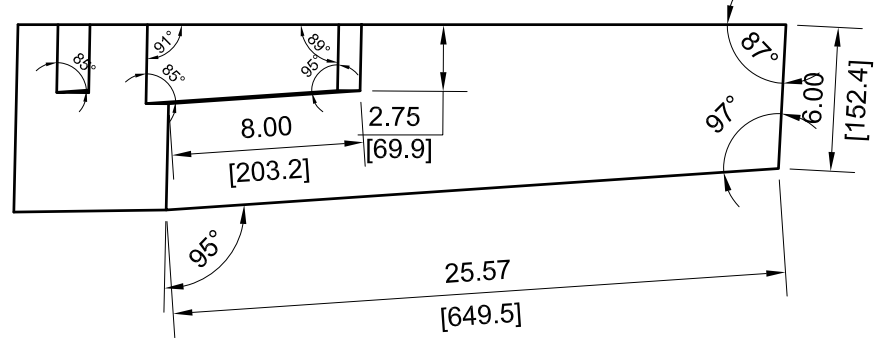
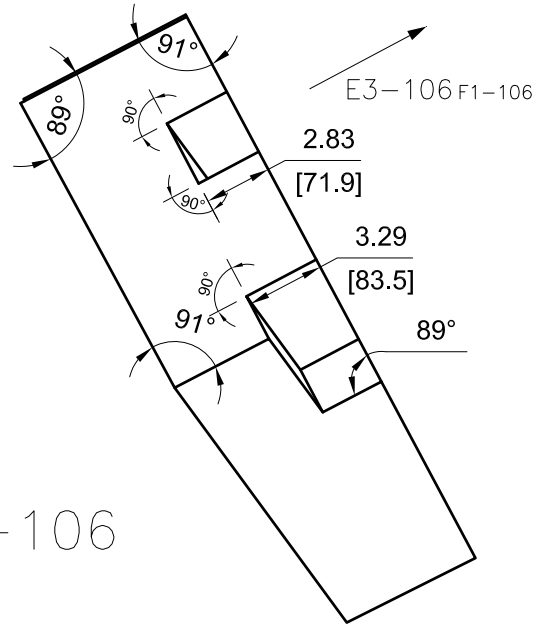
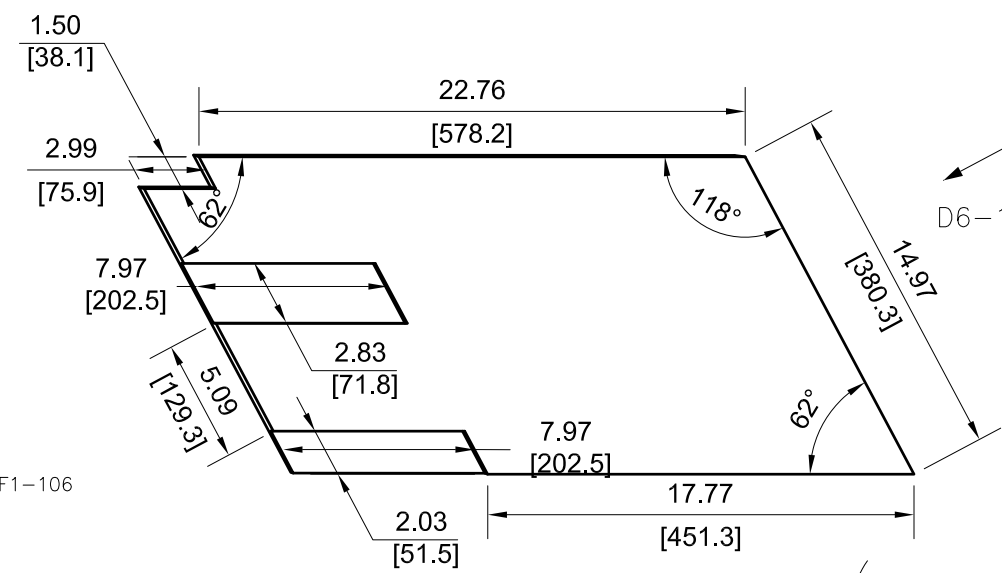
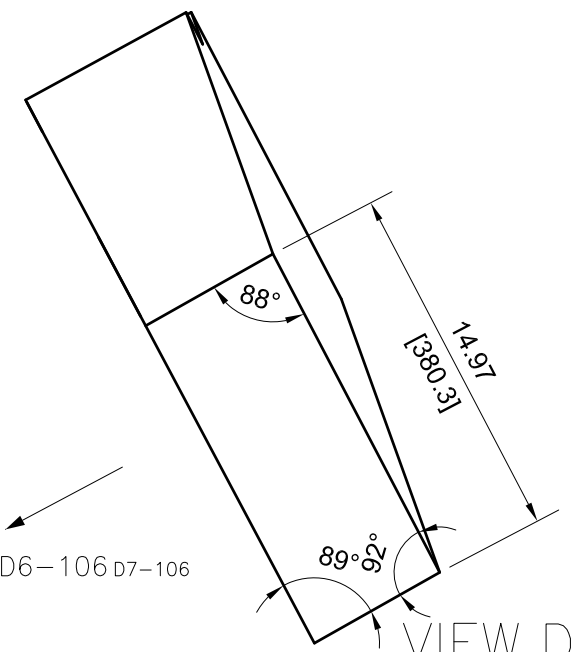
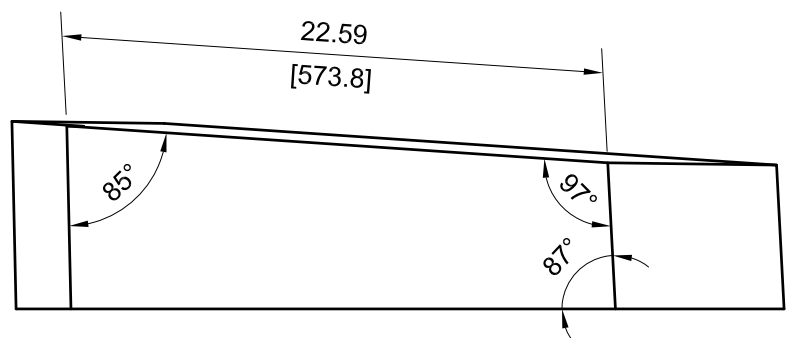
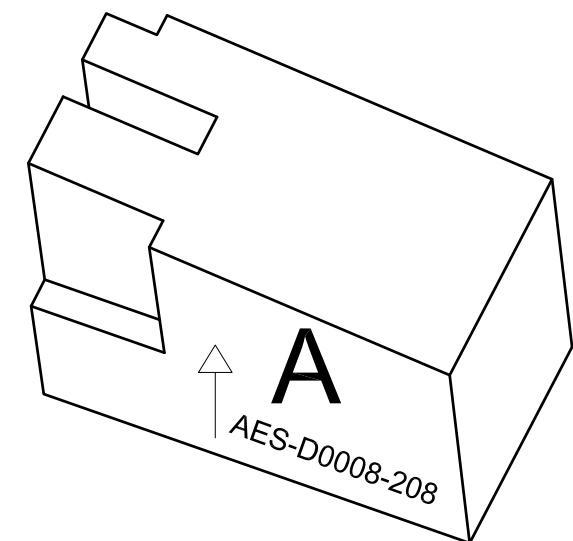

VIEW E3-106



DRAWING NUMBER				
AES-D0008				
SIZE	SCALE	SHEET	OF	REVISION
A3	NONE	106	190	B

210

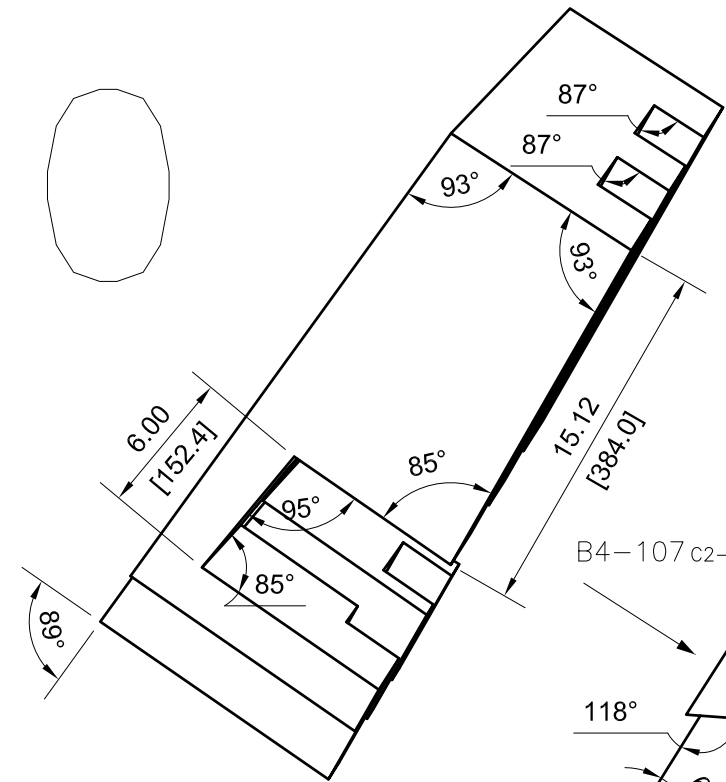

VIEW B4-107

VIEW C5-107

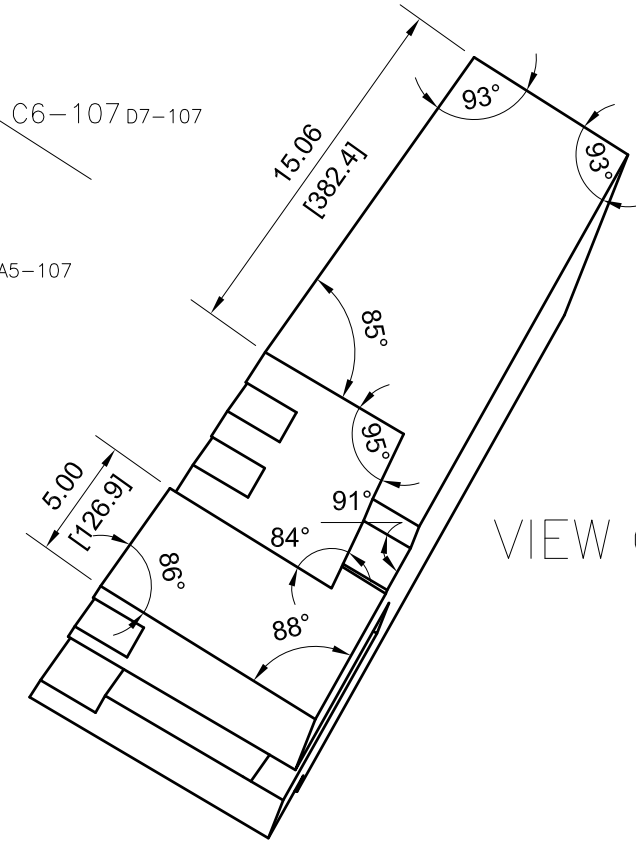
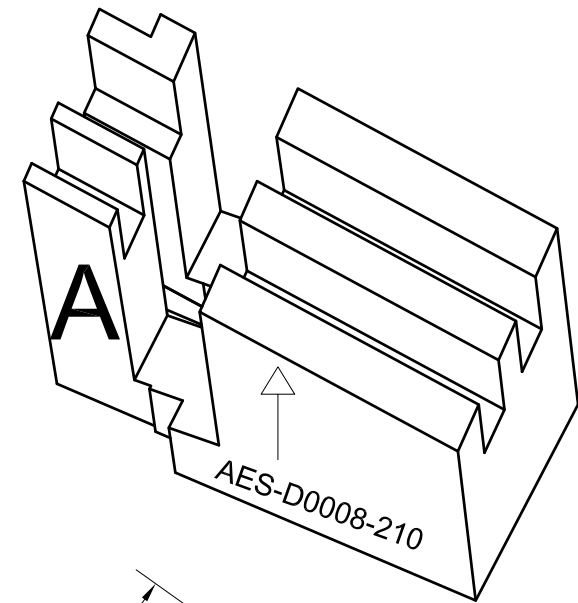
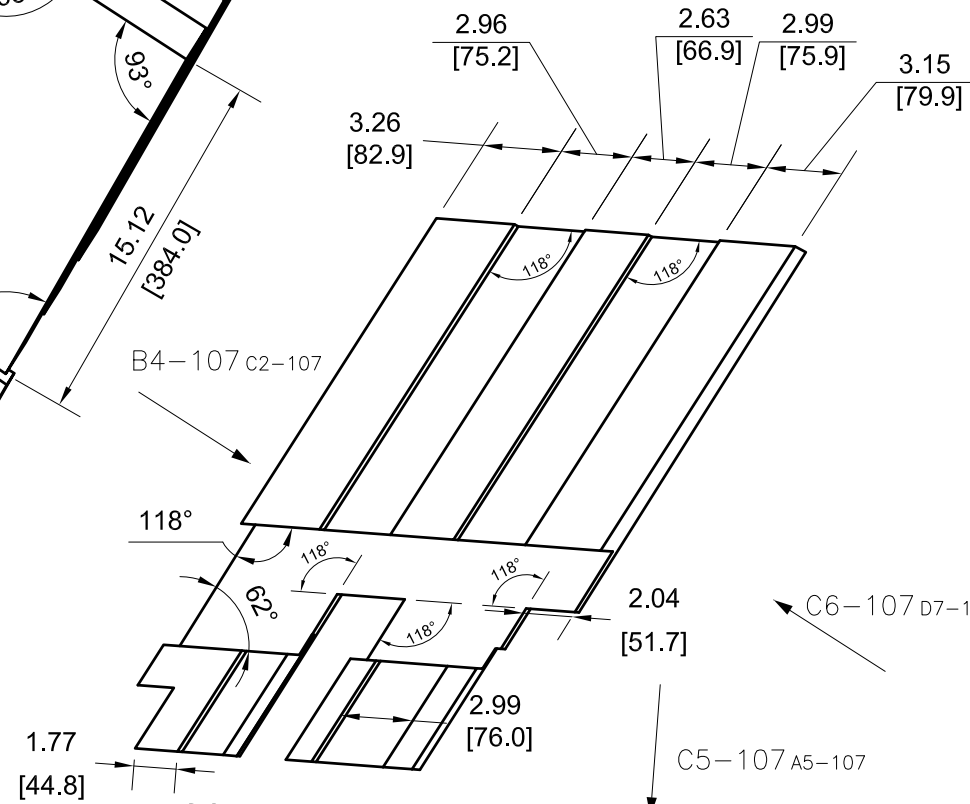

VIEW C6-107

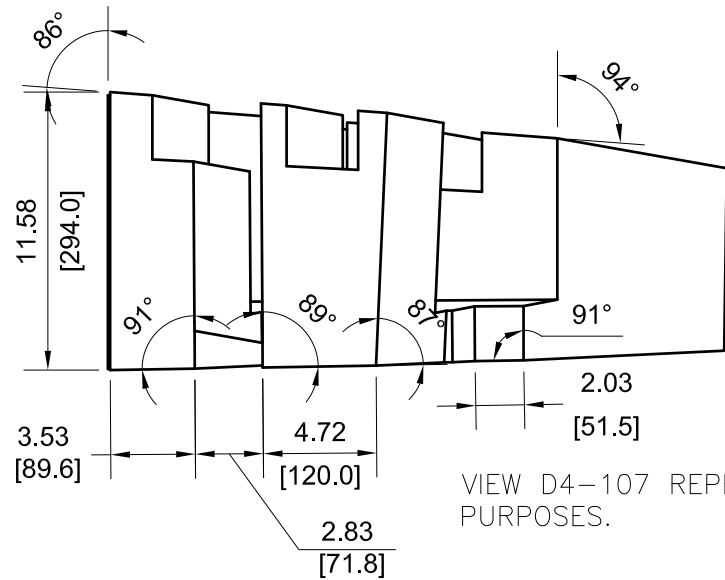
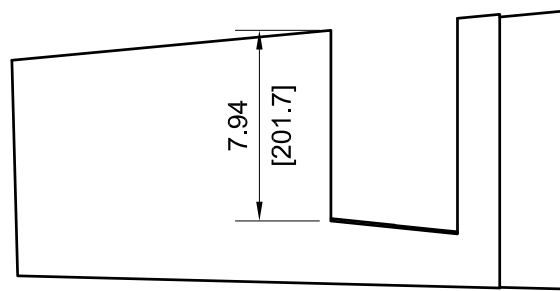

VIEW D4-107 REPEATED FOR CLARITY PURPOSES.

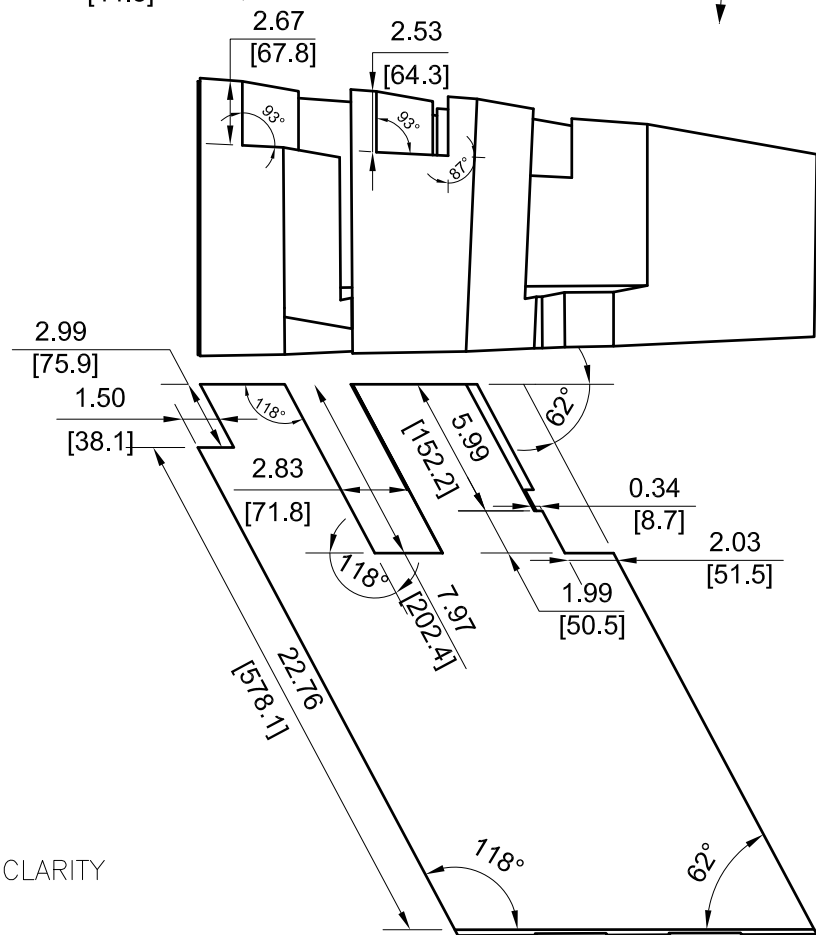

		DRAWING NUMBER			
		AES-D0008			
SIZE	SCALE	SHEET	OF	REVISION	
A3	NONE	107	190	B	

212

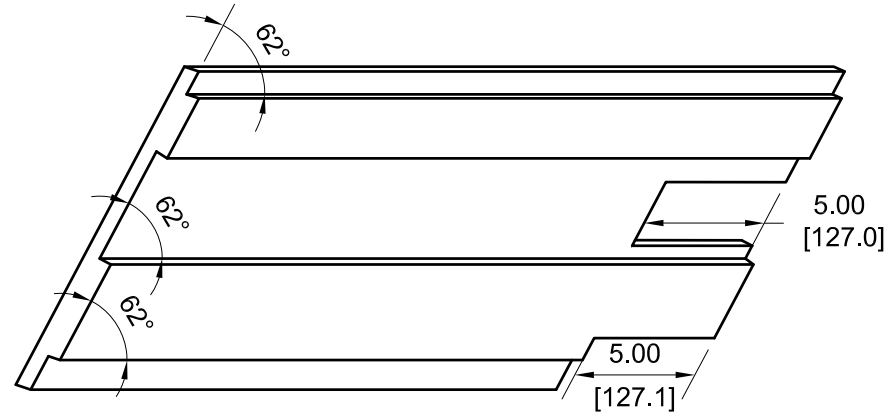
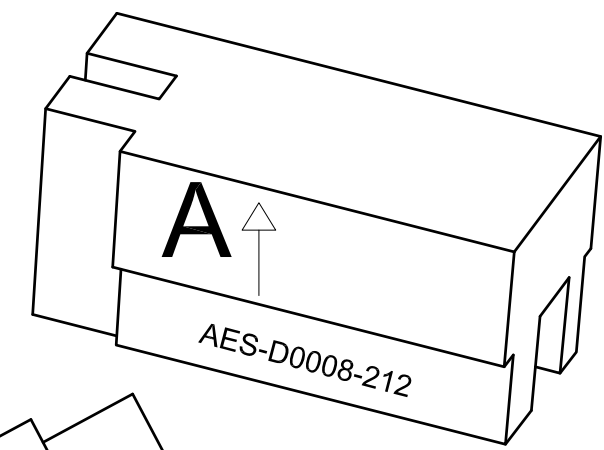
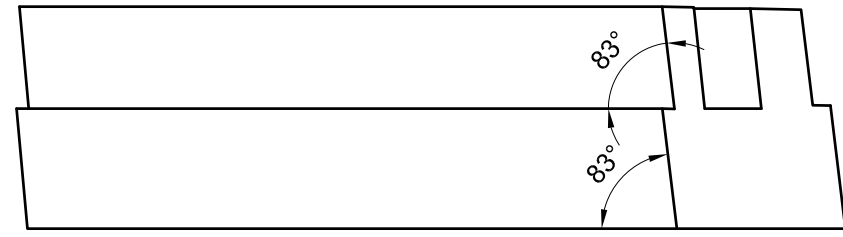

REAR VIEW RELATIVE TO VIEW D4-108

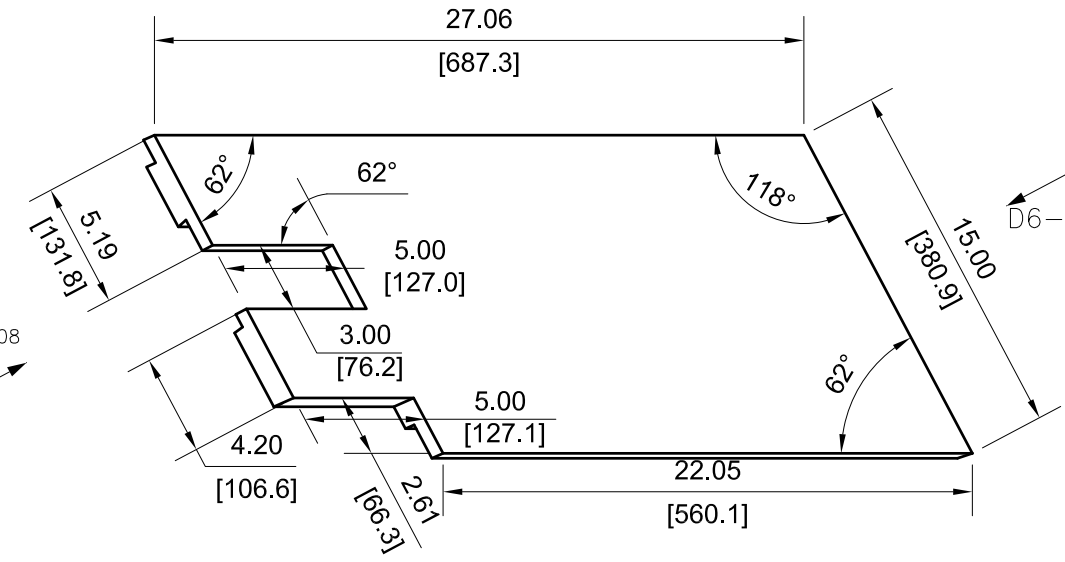

D3-108 F1-108

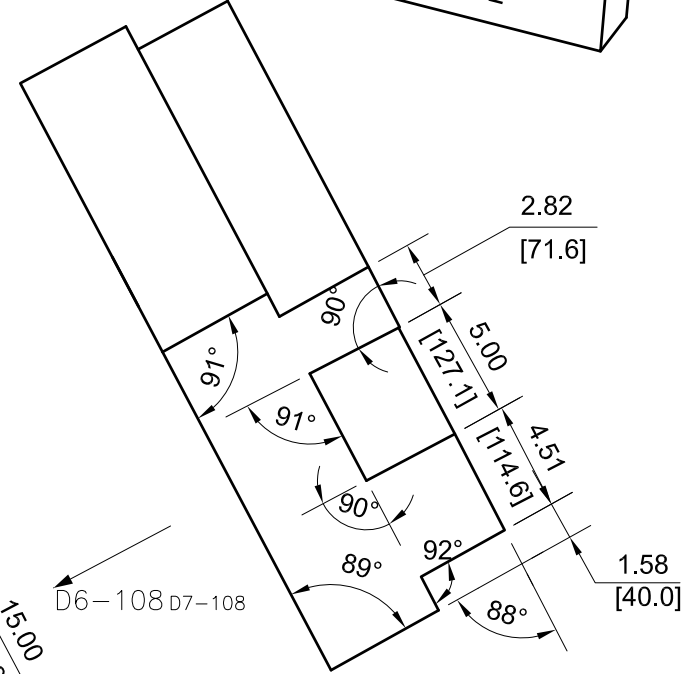

VIEW D6-108

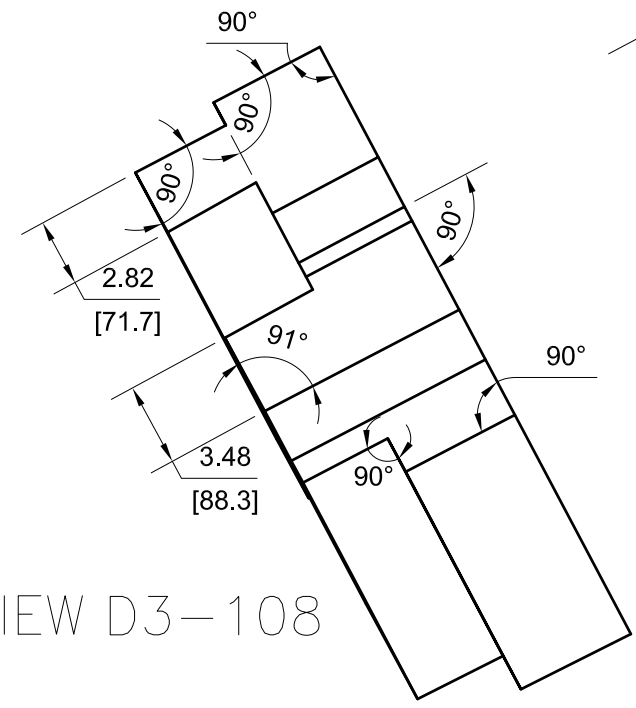

VIEW D3-108

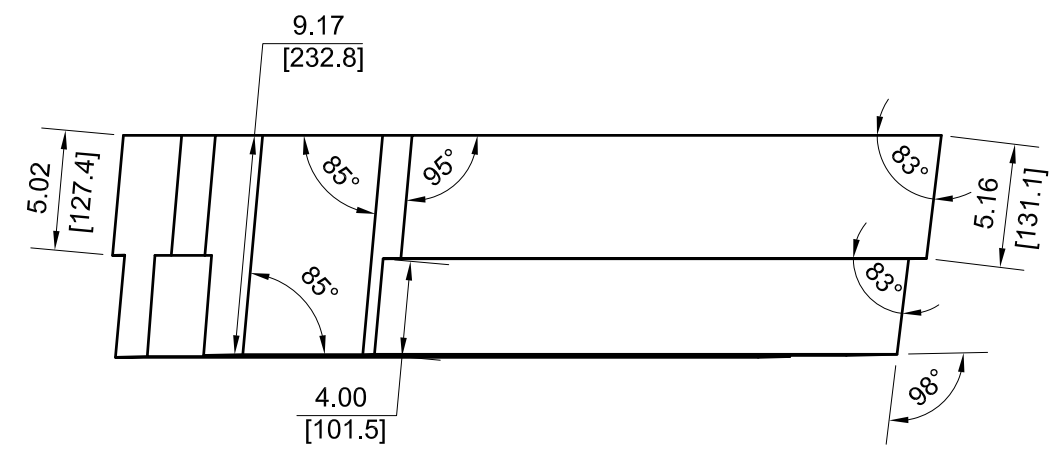

		DRAWING NUMBER			
		AES-D0008			
SIZE	SCALE	SHEET	OF	REVISION	
A3	NONE	108	190	B	

— 214

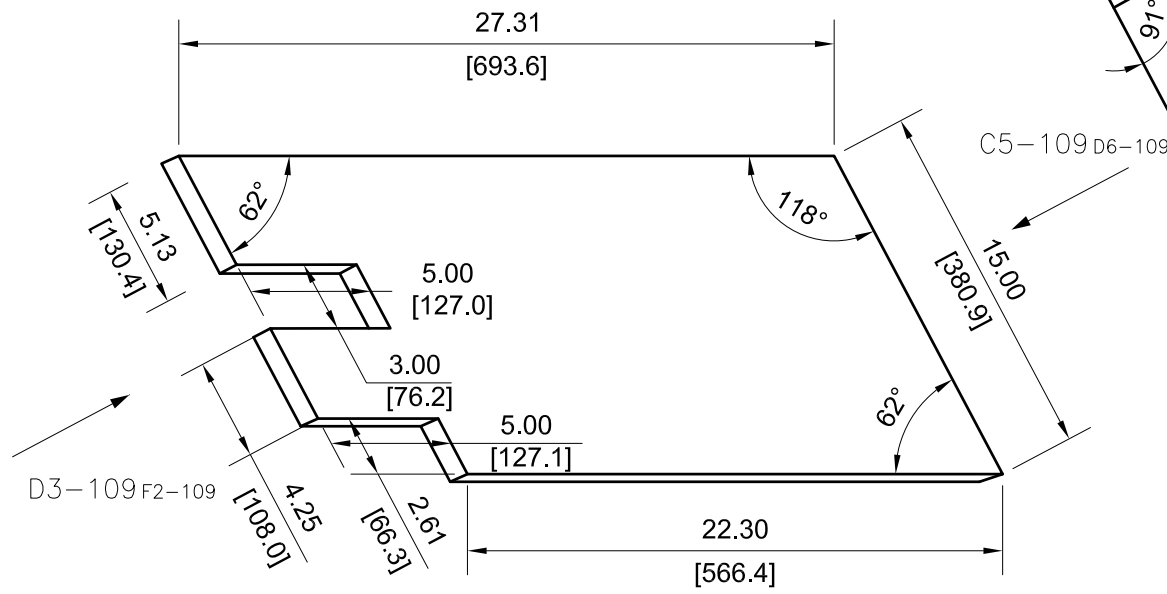
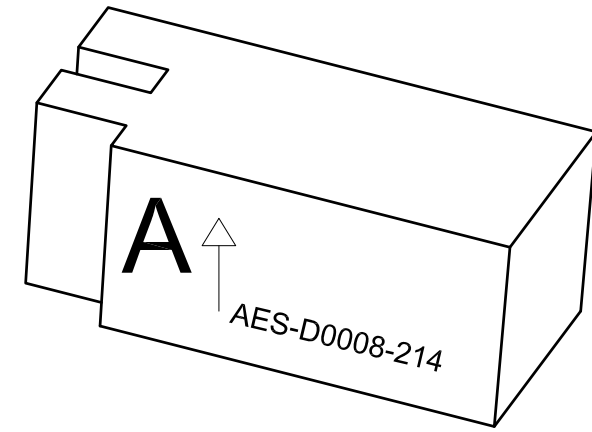

VIEW C5-109

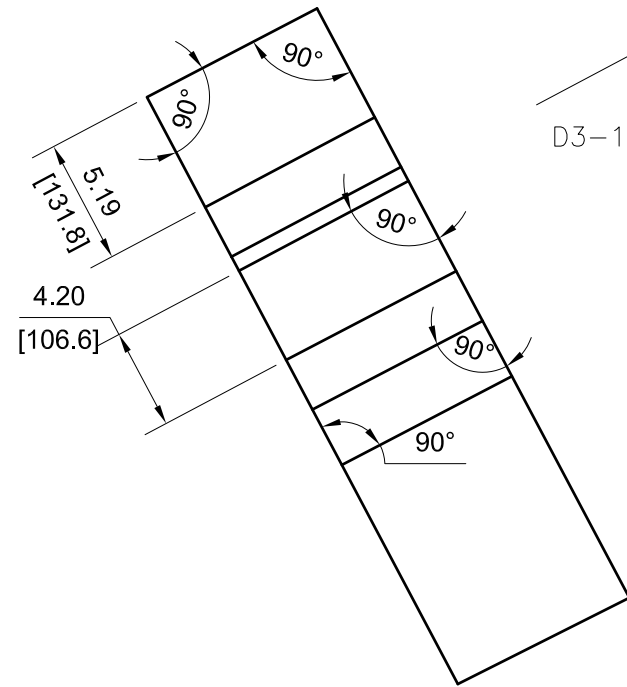

VIEW D3-109

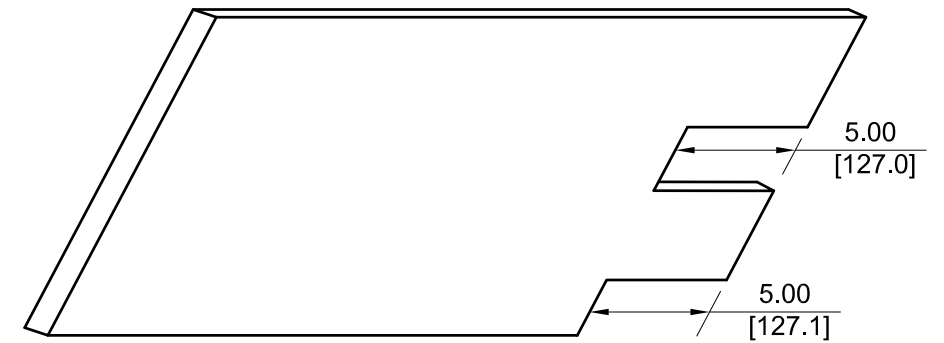
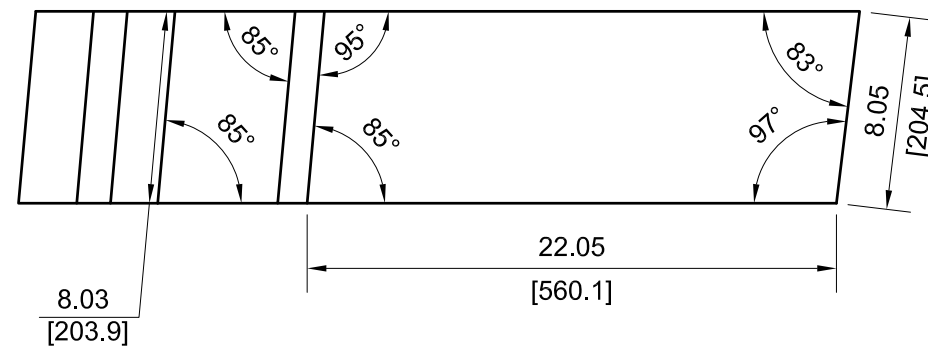

REAR VIEW RELATIVE TO VIEW D4-109



DRAWING NUMBER				
AES-D0008				
SIZE	SCALE	SHEET	OF	REVISION
A3	NONE	109	190	B

-216

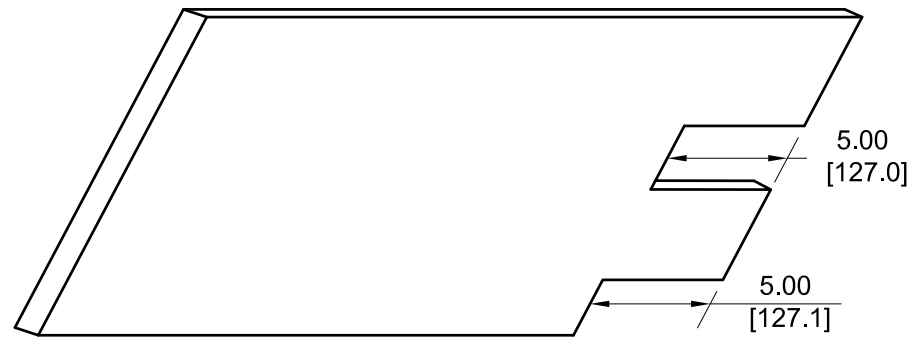

REAR VIEW RELATIVE TO VIEW D4-110

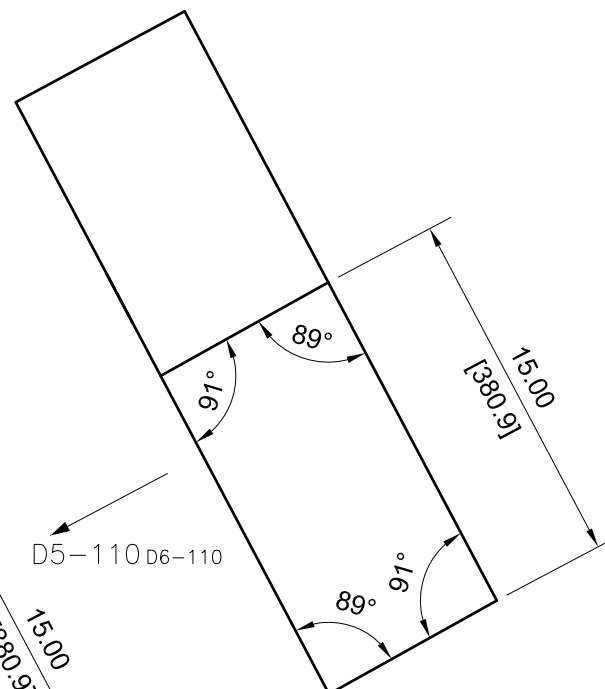
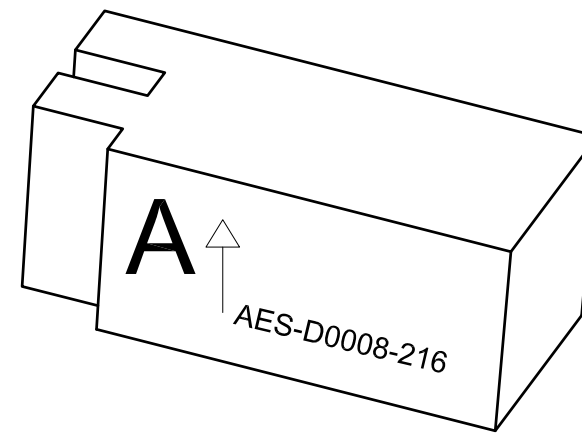

VIEW D5-110

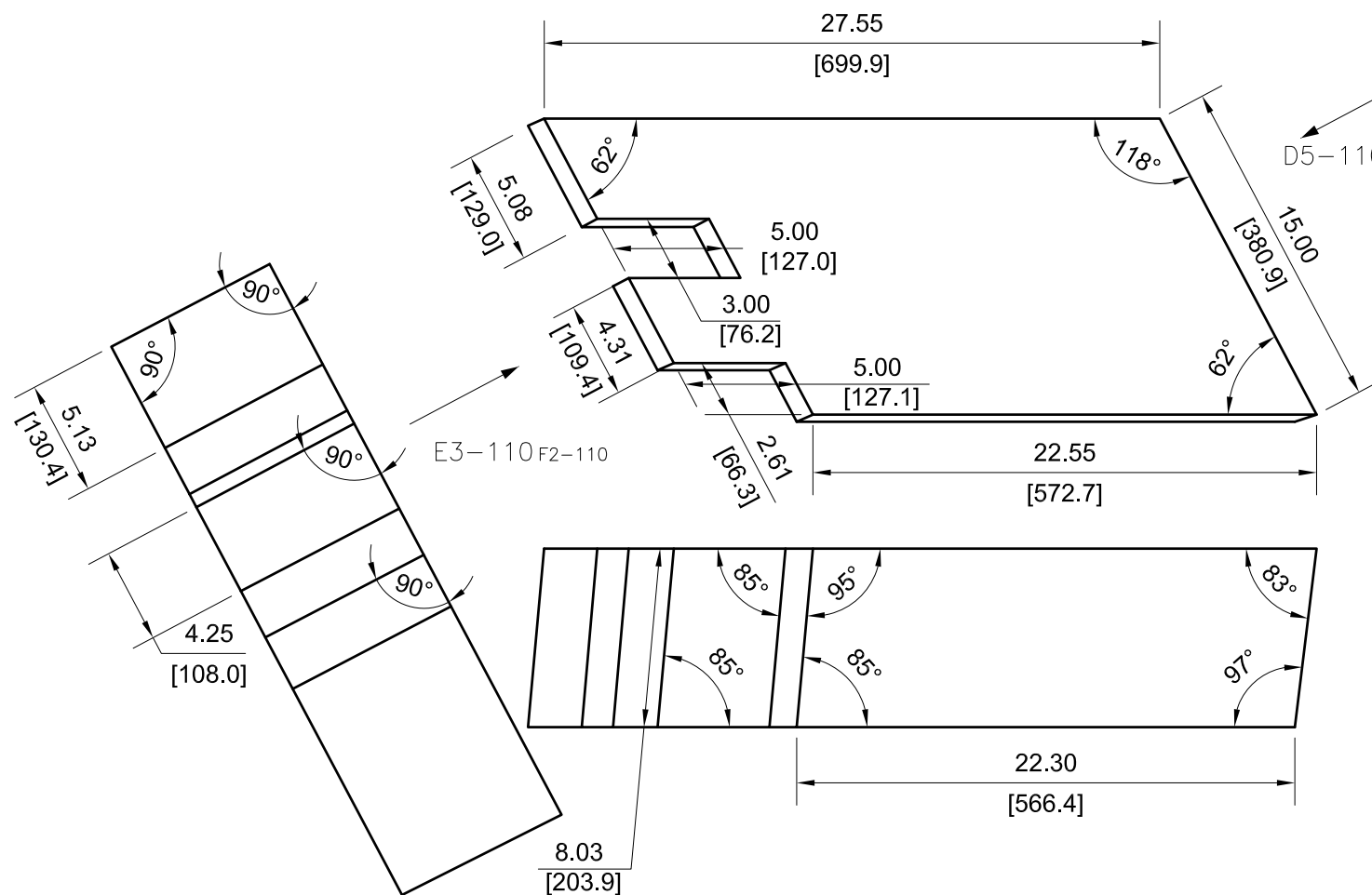

VIEW E3-110



DRAWING NUMBER					AES-D0008	
SIZE	SCALE	SHEET	OF	REVISION		
A3	NONE	110	190	B		

— 218

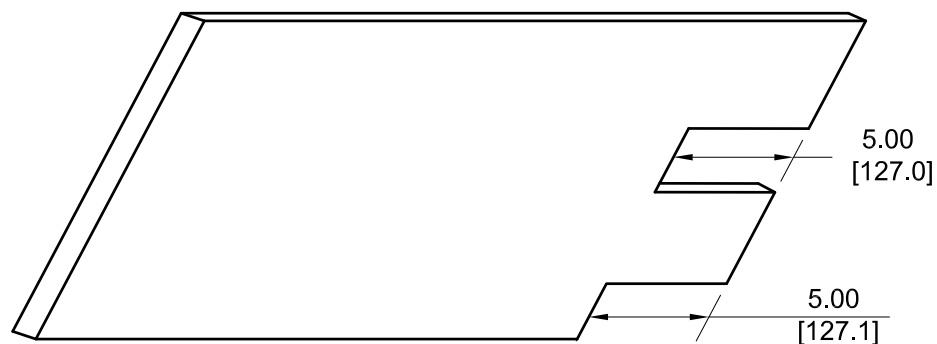

REAR VIEW RELATIVE TO VIEW D4-111

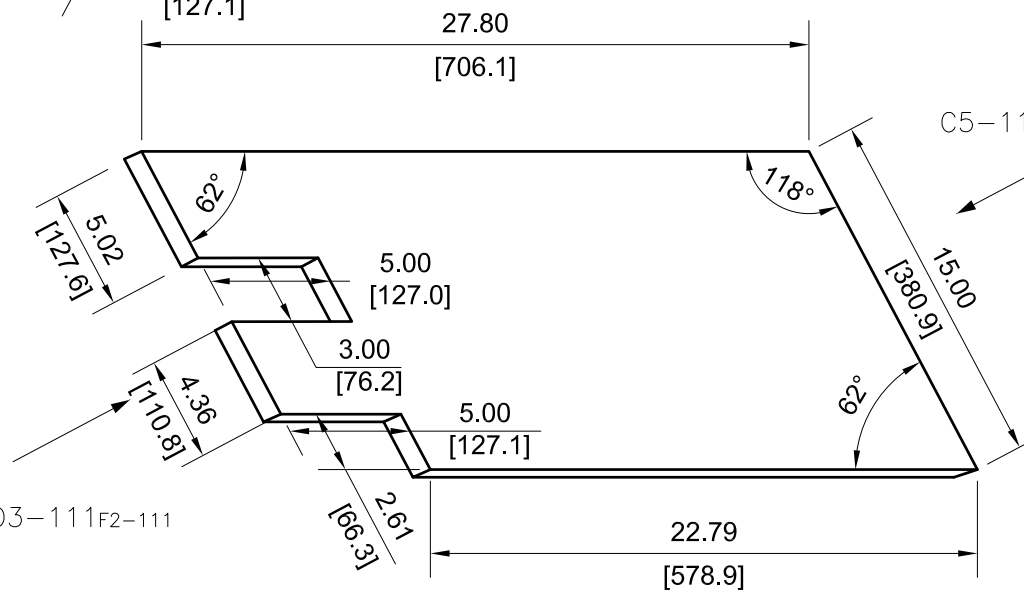

VIEW C5-111

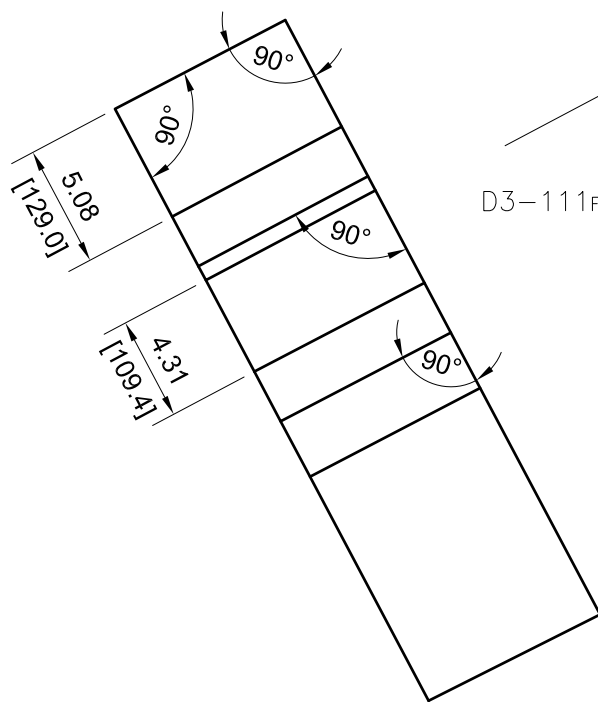

VIEW D3-111

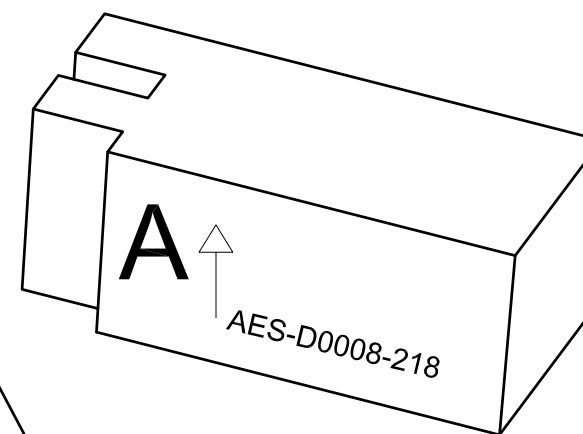
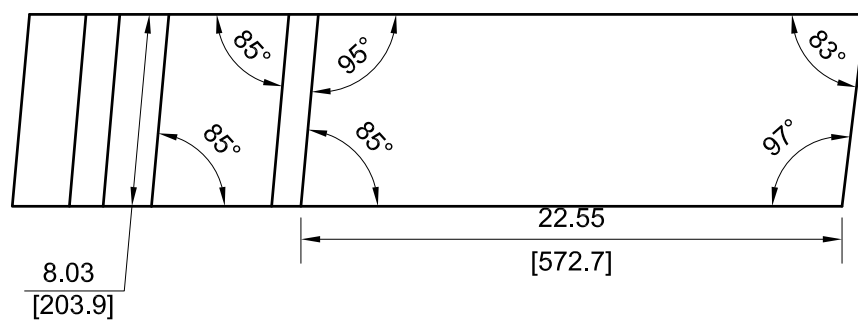

DRAWING NUMBER				
AES-D0008				
SIZE	SCALE	SHEET	OF	REVISION
A3	NONE	111	190	B

— 220

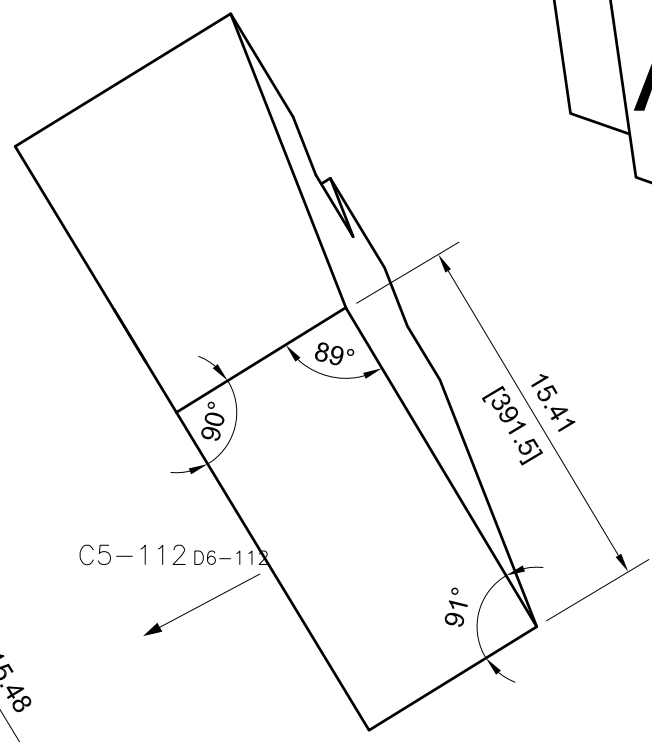
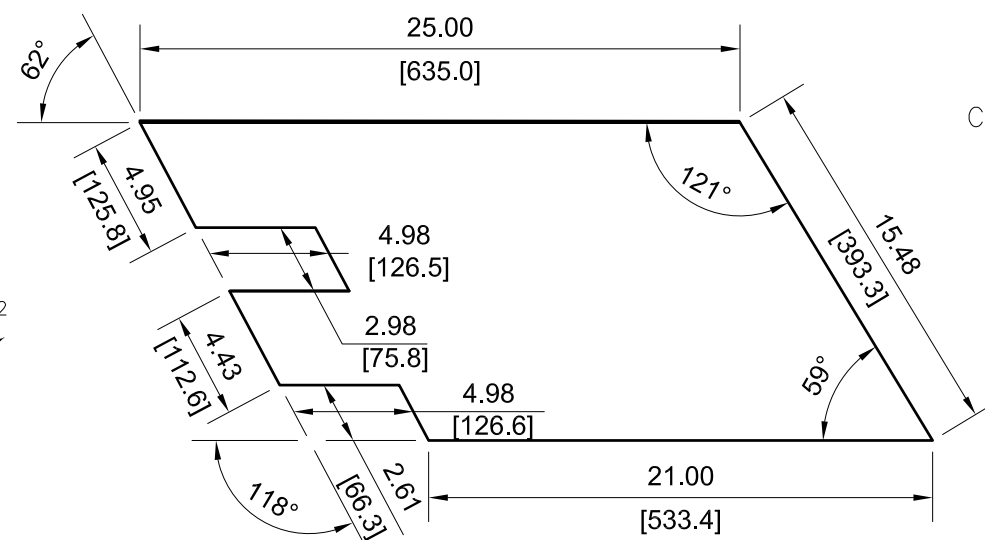
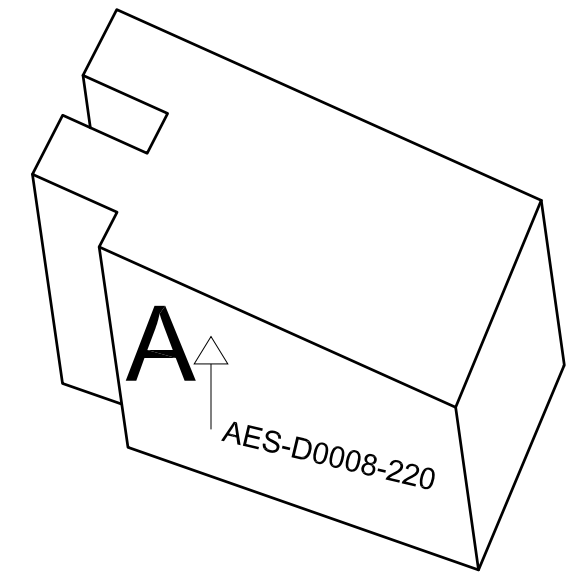

VIEW C5-112

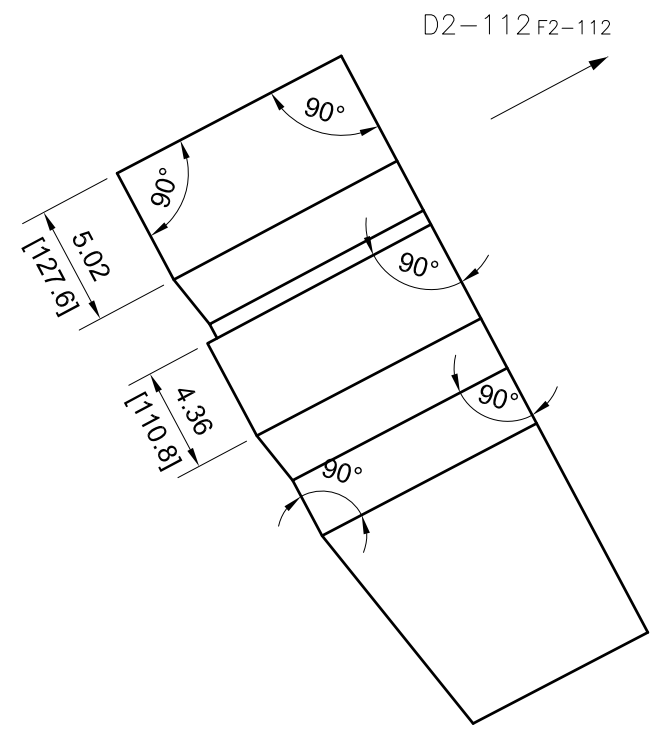

VIEW D2-112

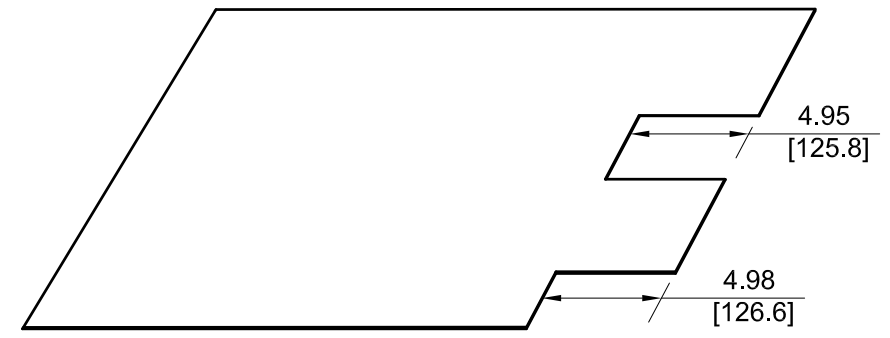
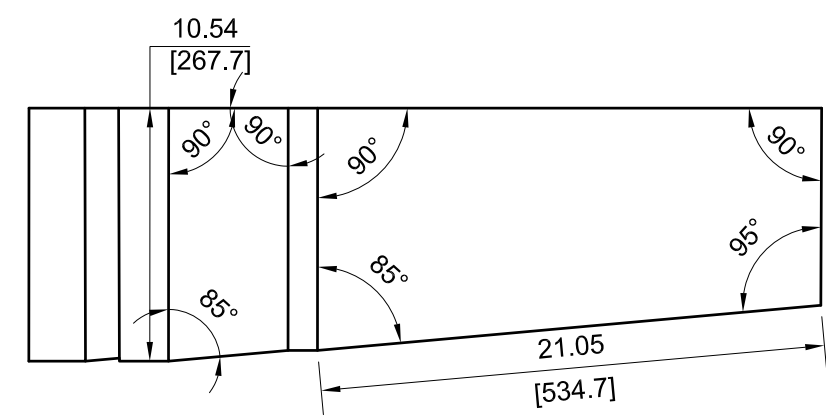

REAR VIEW RELATIVE TO VIEW D4-112

		DRAWING NUMBER			
		AES-D0008			
SIZE	SCALE	SHEET	OF	REVISION	
A3	NONE	112	190	B	

222

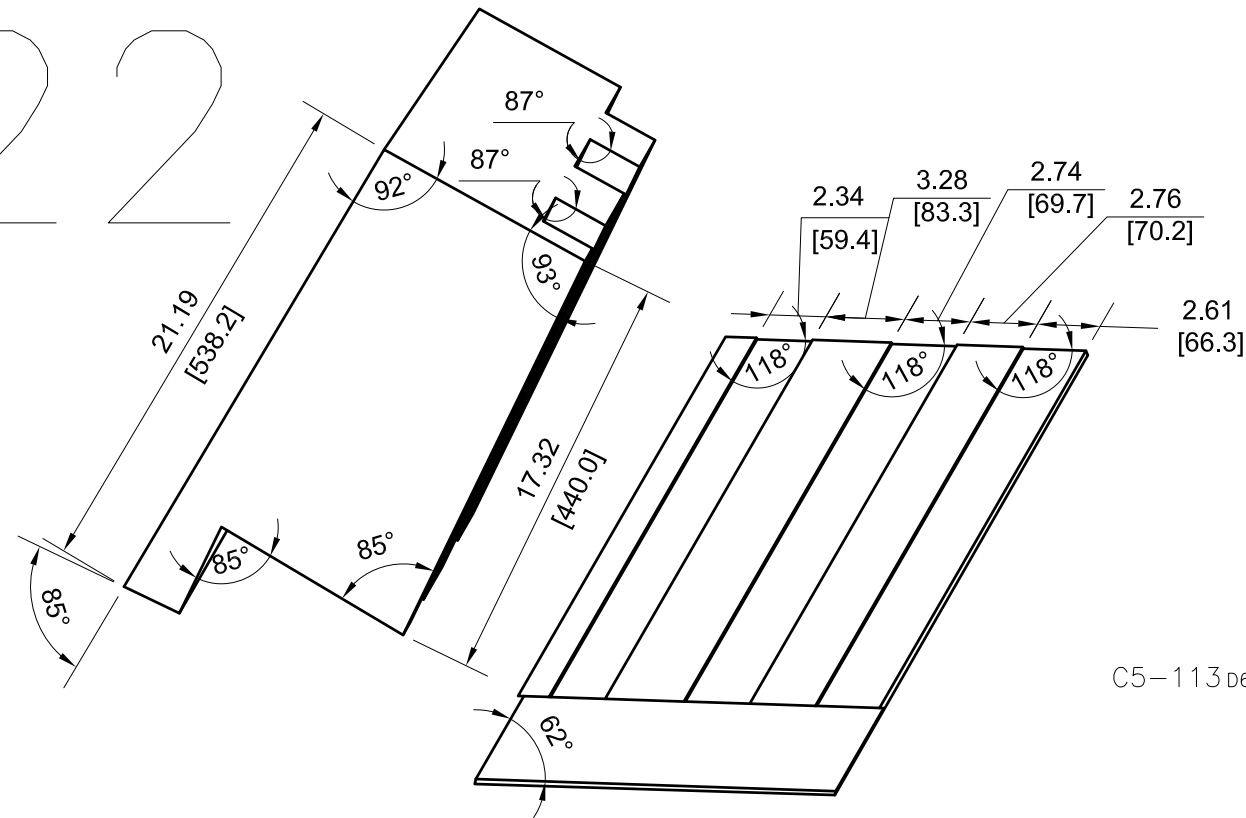

VIEW D2-113

D2-113 C1-113

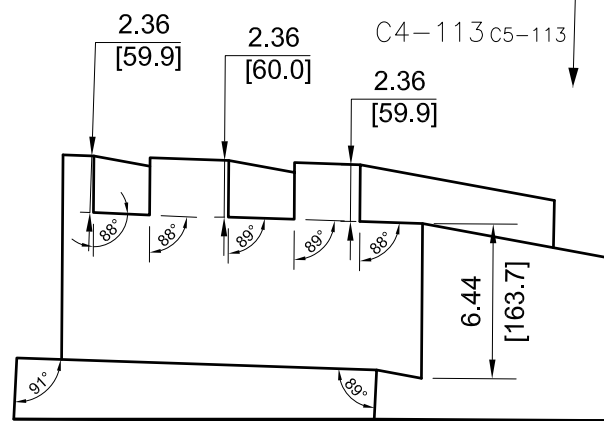

VIEW C4-113

C5-113 D6-113

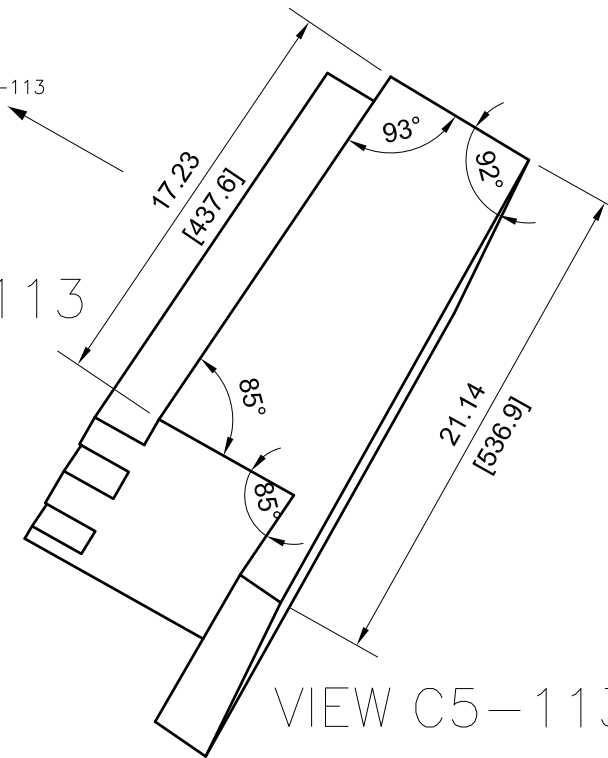

VIEW C5-113

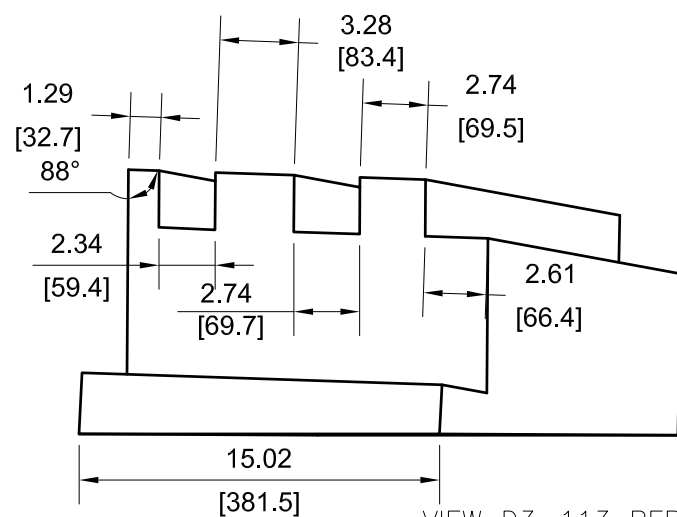
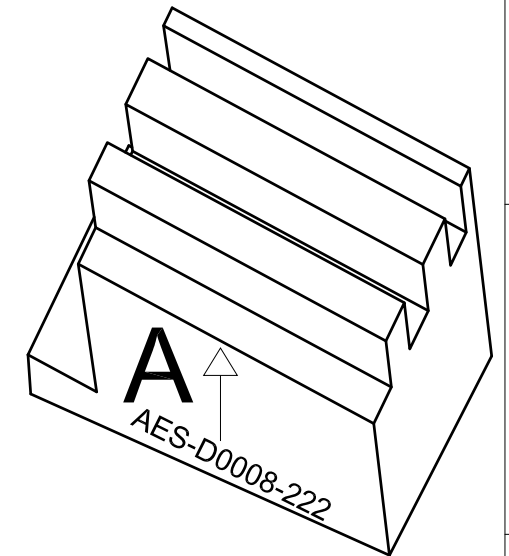

VIEW D3-113 REPEATED FOR CLARITY PURPOSES.

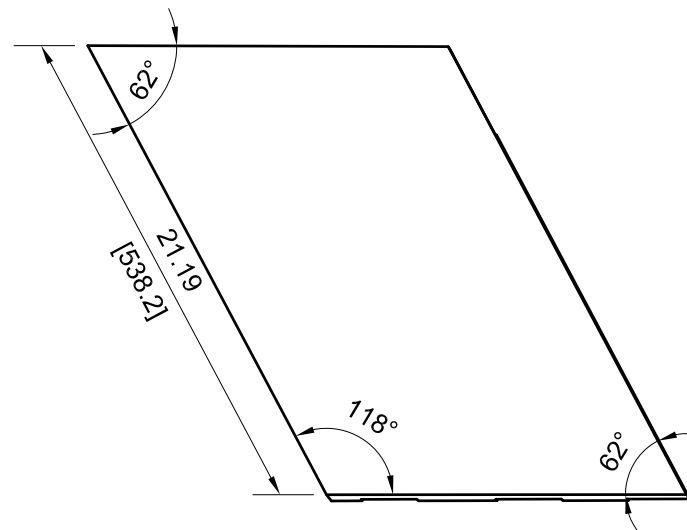

		DRAWING NUMBER			
		AES-D0008			
SIZE	SCALE	SHEET	OF	REVISION	
A3	NONE	113	190	B	

224

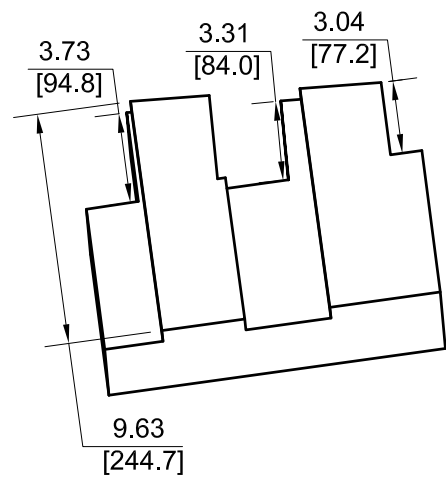

VIEW B3-114

B3-114 c2-114

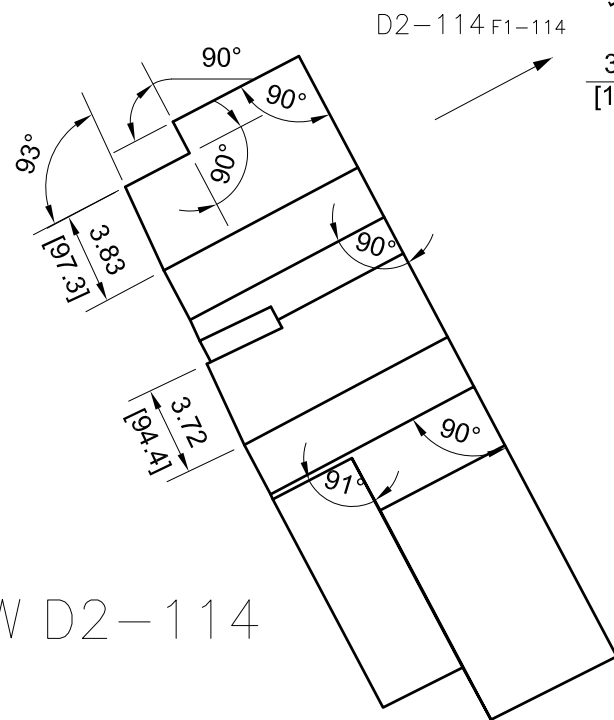
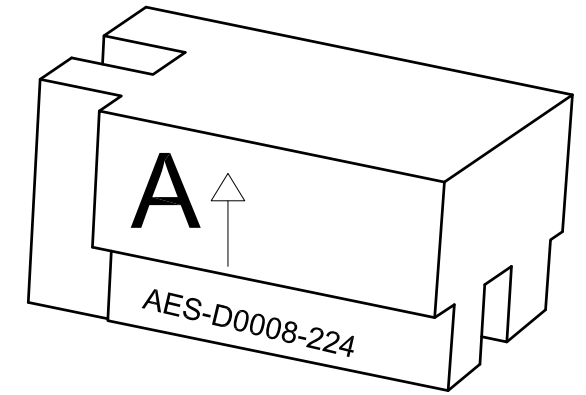
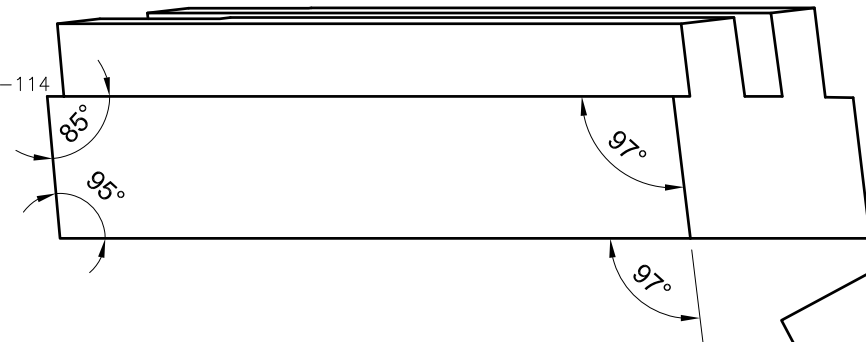

VIEW D2-114

D2-114 F1-114

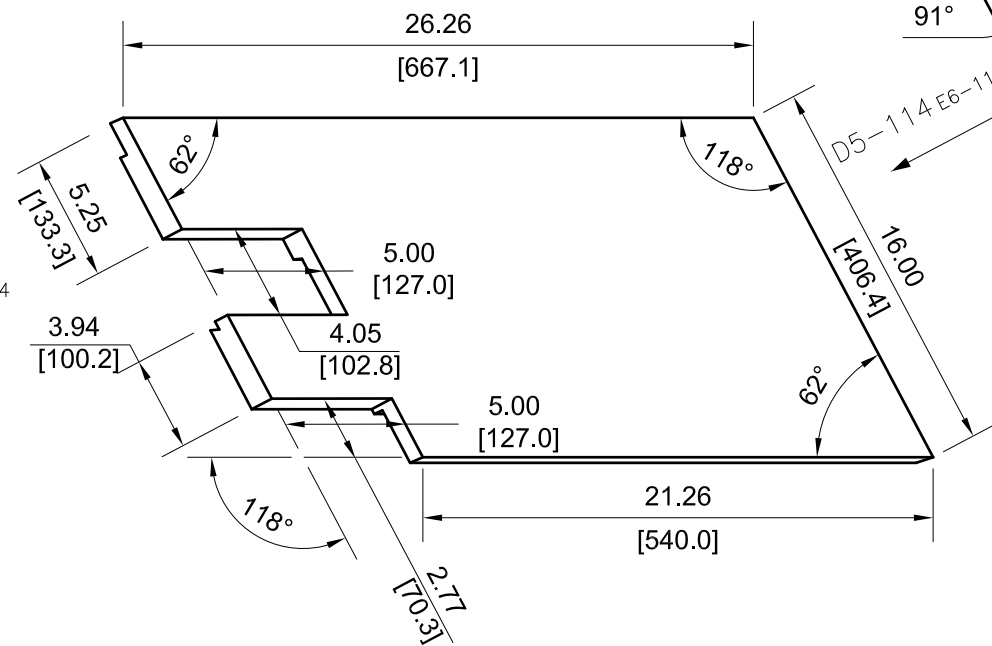

VIEW D5-114

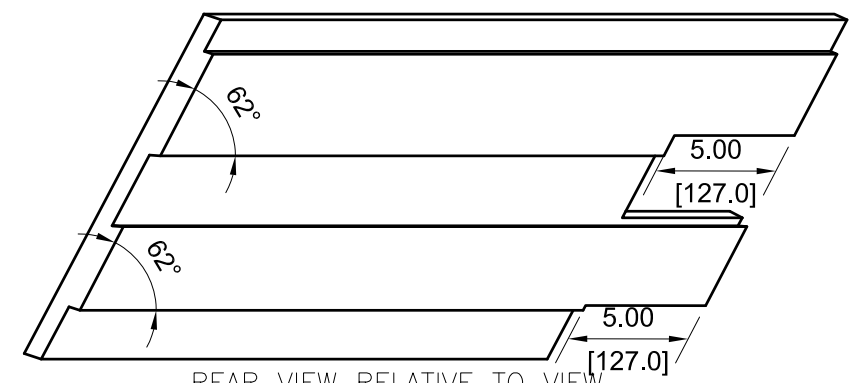
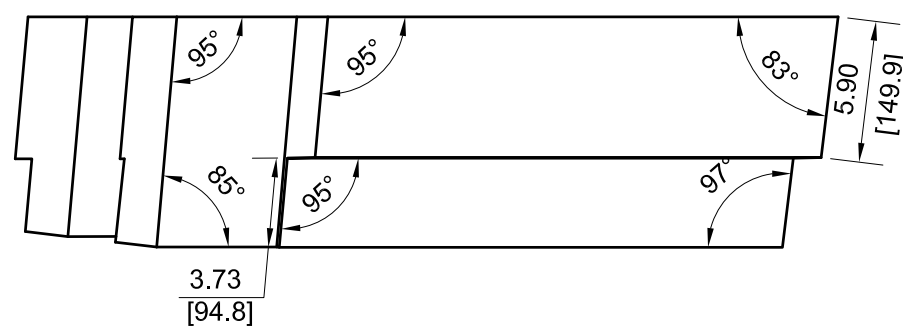
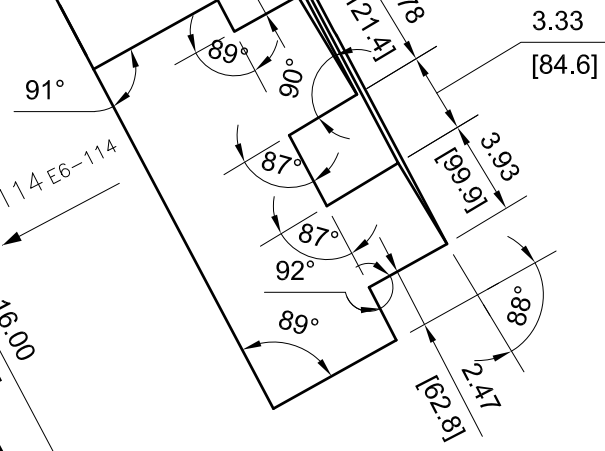

REAR VIEW RELATIVE TO VIEW D4-114



DRAWING NUMBER				
AES-D0008				
SIZE	SCALE	SHEET	OF	REVISION
A3	NONE	114	190	B

— 226

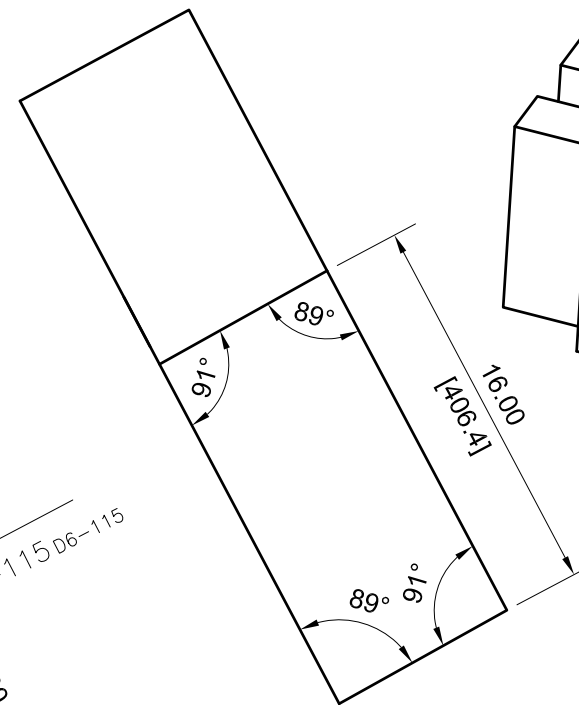
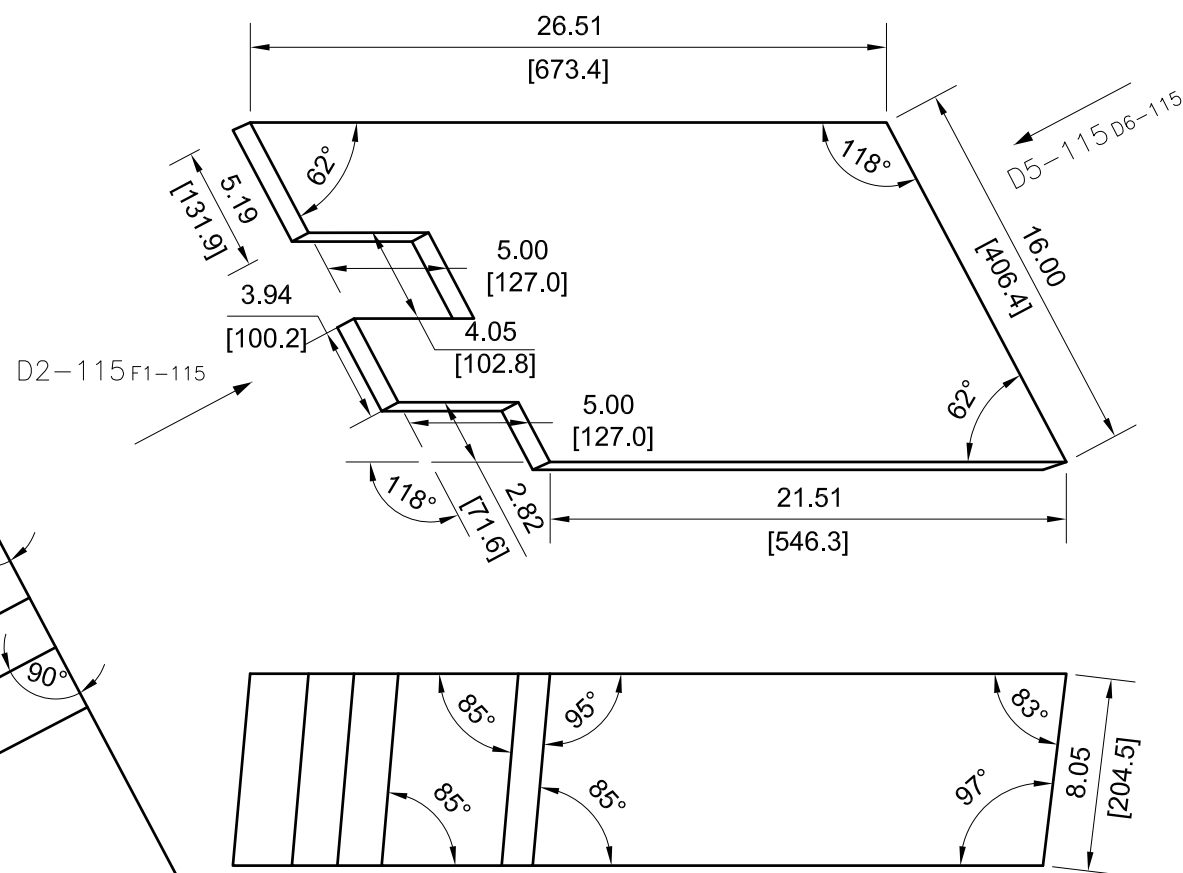
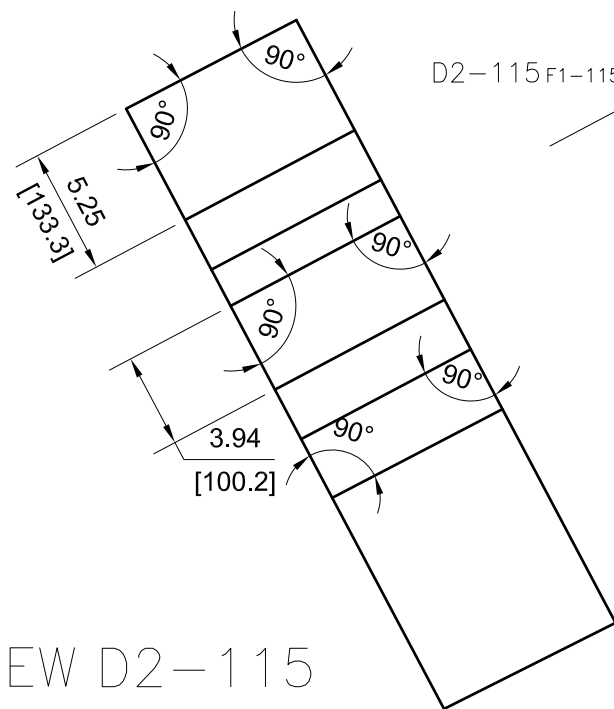

VIEW D5-115

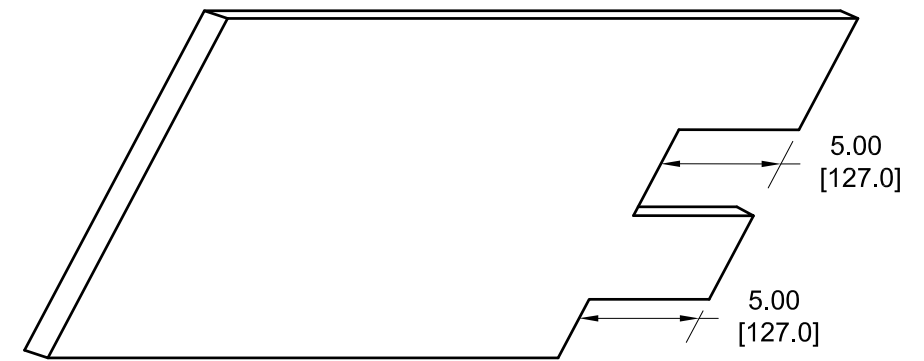

REAR VIEW RELATIVE TO VIEW D4-115

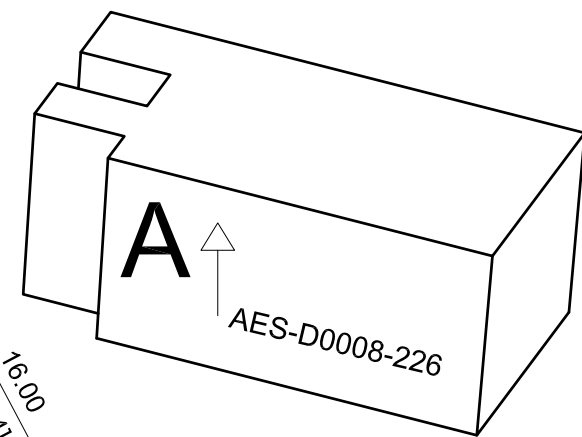

VIEW D2-115



DRAWING NUMBER				
AES-D0008				
SIZE	SCALE	SHEET	OF	REVISION
A3	NONE	115	190	B

— 228

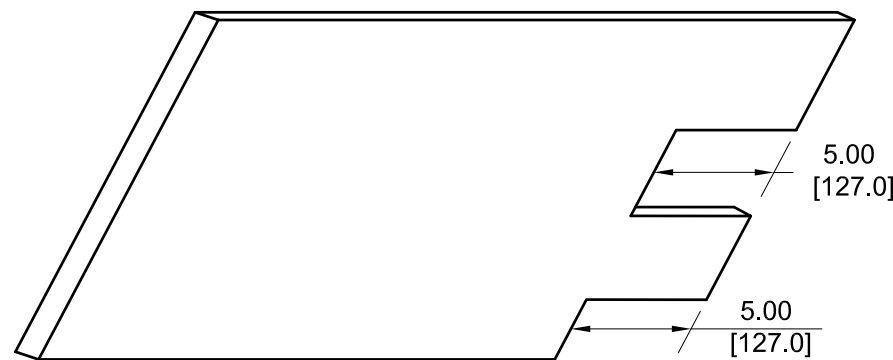
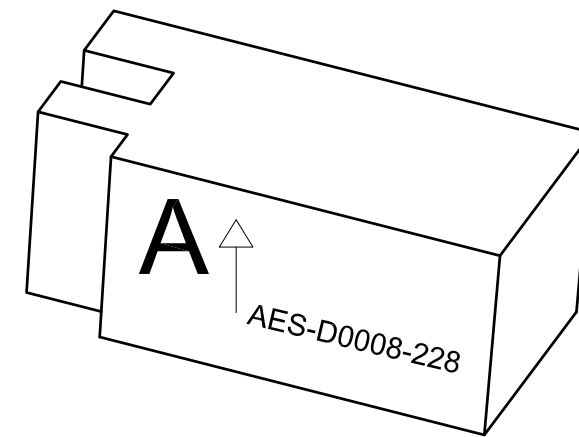

REAR VIEW RELATIVE TO VIEW D4-116

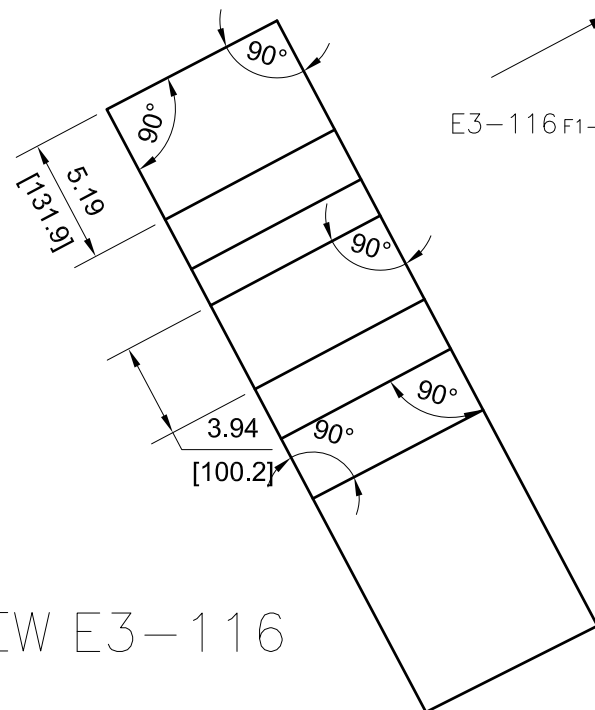

VIEW E3-116

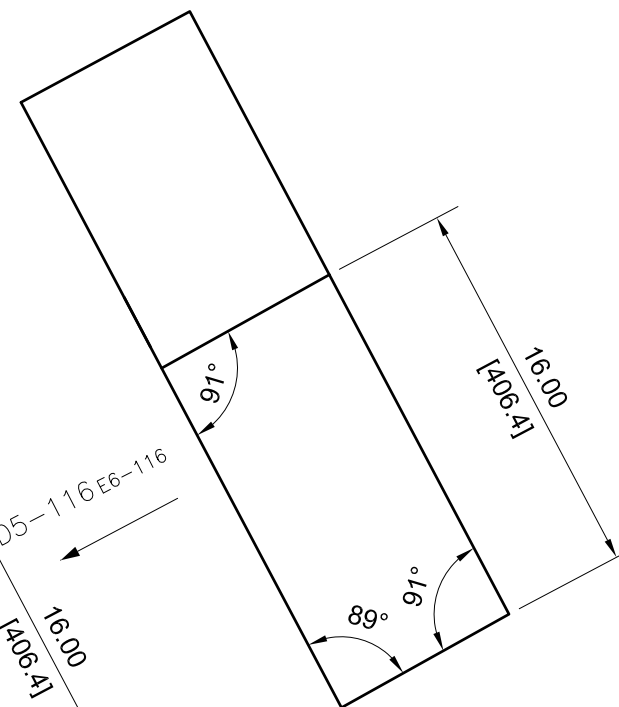
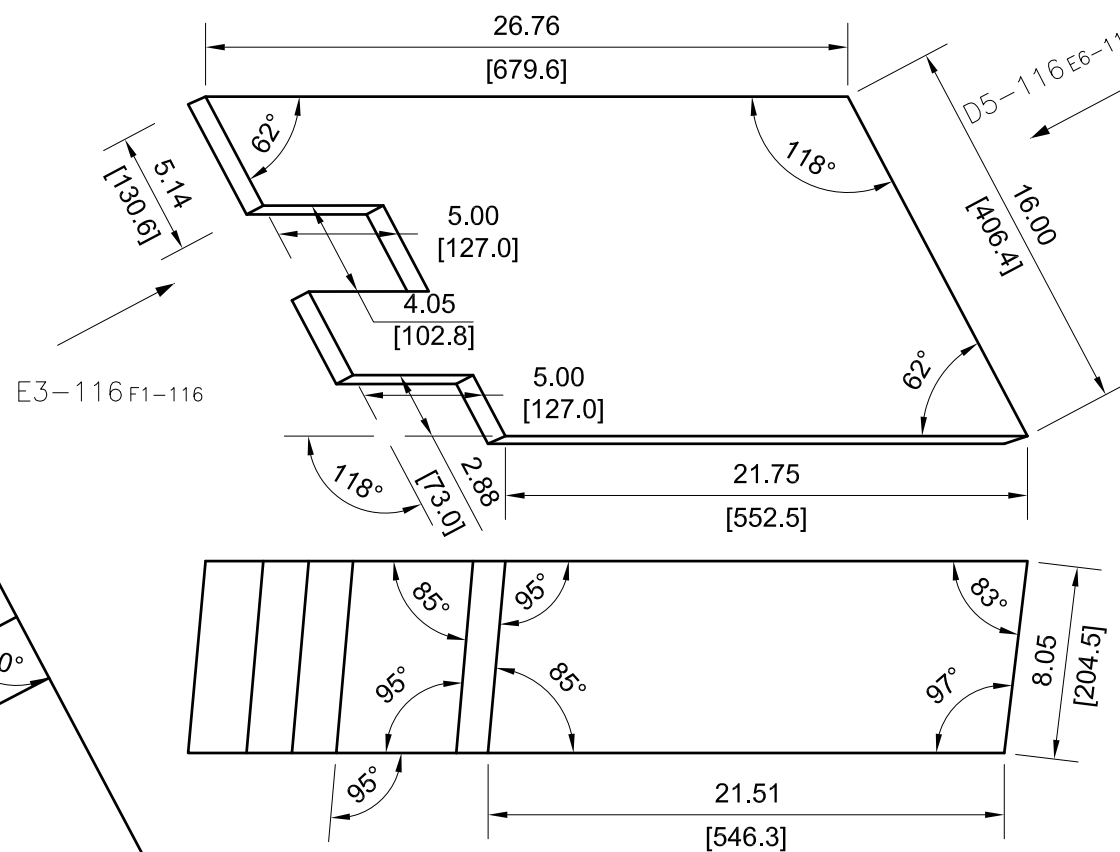

VIEW D5-116



DRAWING NUMBER					AES-D0008	
SIZE	SCALE	SHEET	OF	REVISION		
A3	NONE	116	190	B		

— 230

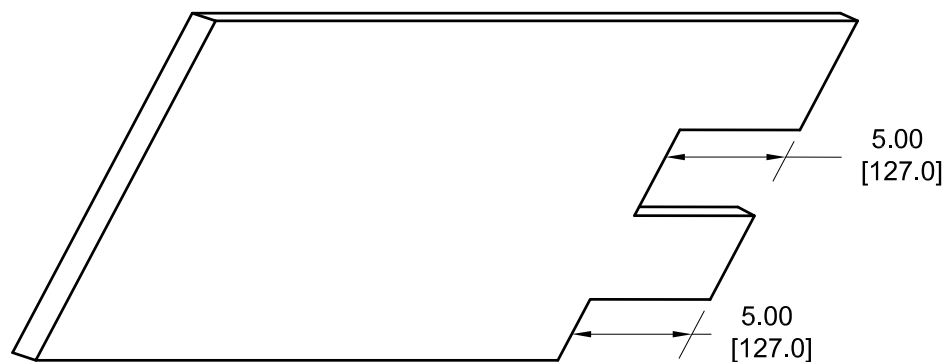
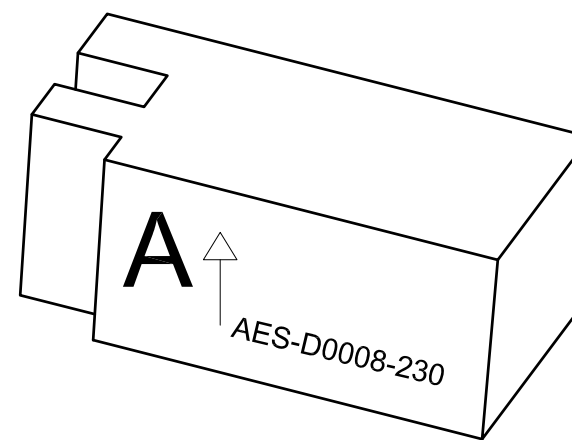

REAR VIEW RELATIVE TO VIEW D4-117

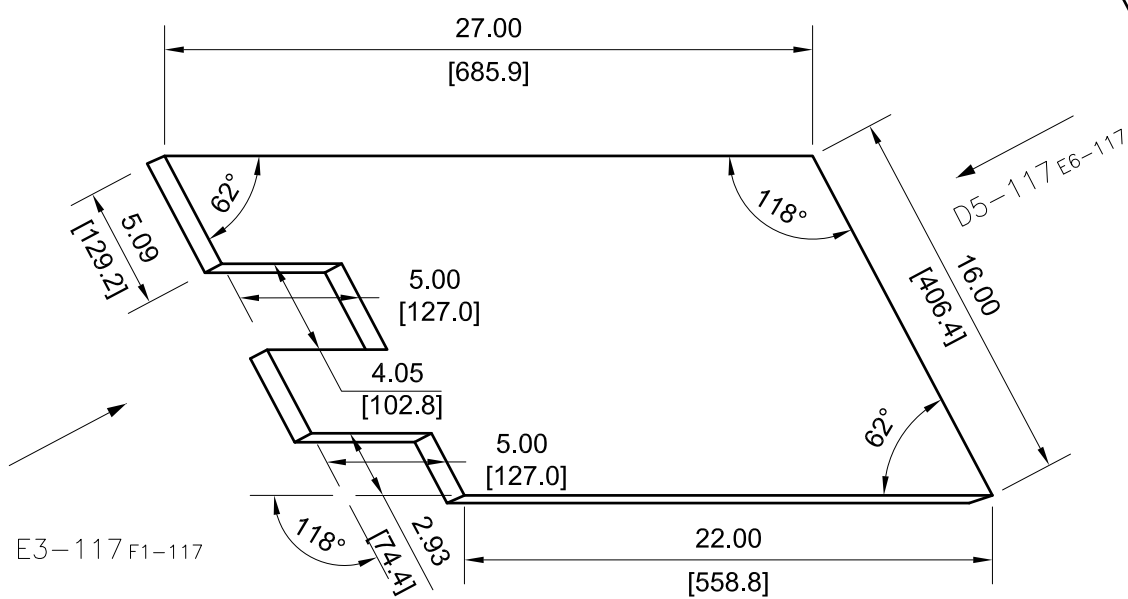

VIEW D5-117

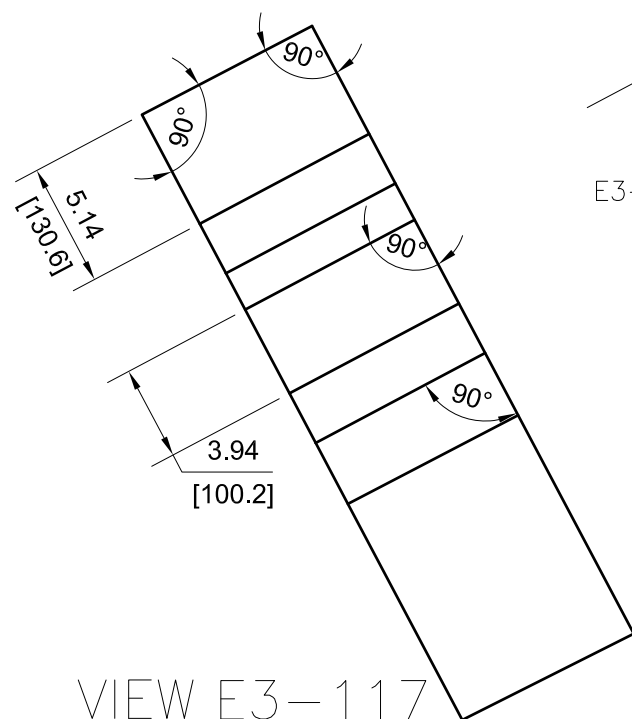

VIEW E3-117

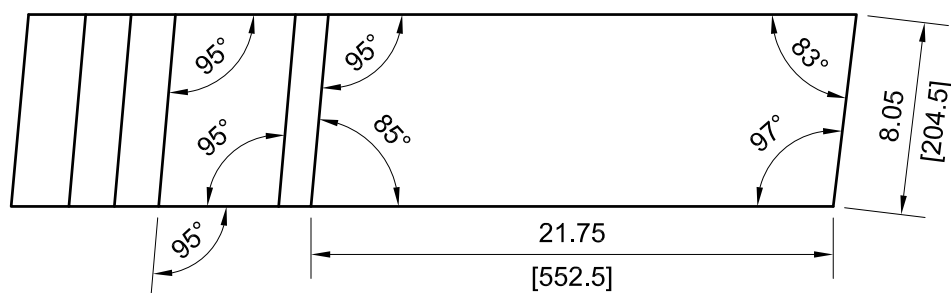

		DRAWING NUMBER			
		AES-D0008			
SIZE	SCALE	SHEET	OF	REVISION	
A3	NONE	117	190	B	

- 232

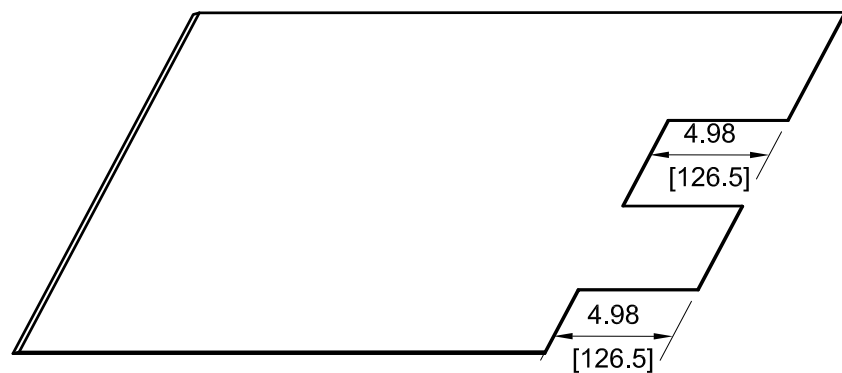
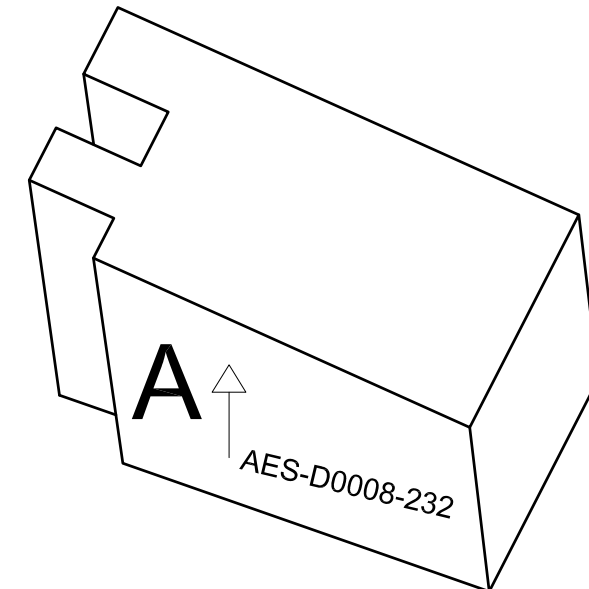

REAR VIEW RELATIVE TO VIEW D4-118

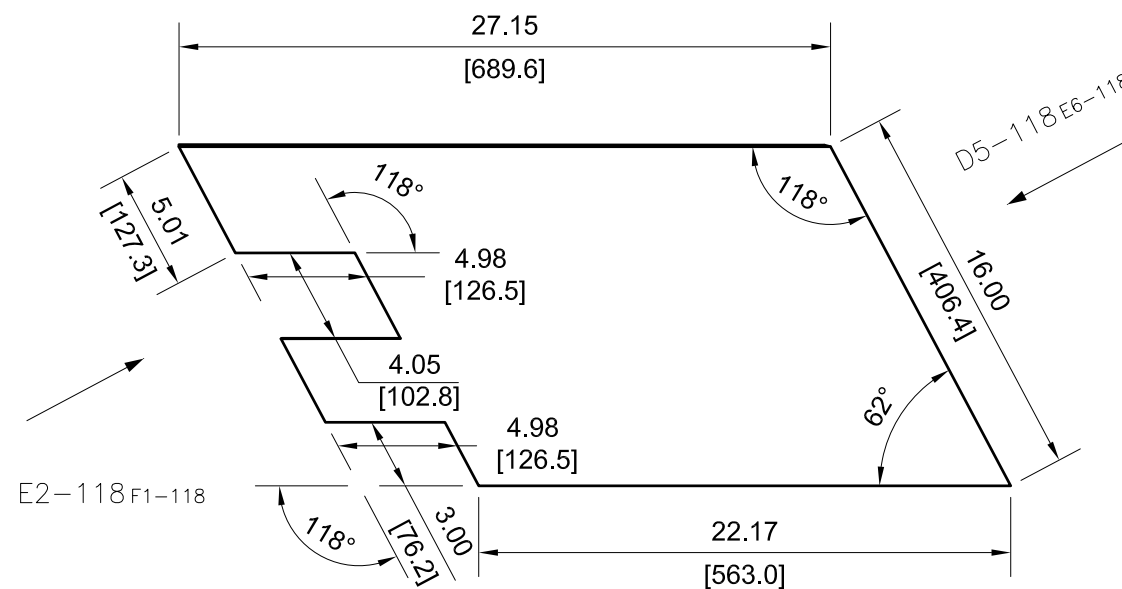

D5-118 E6-118

VIEW D5-118

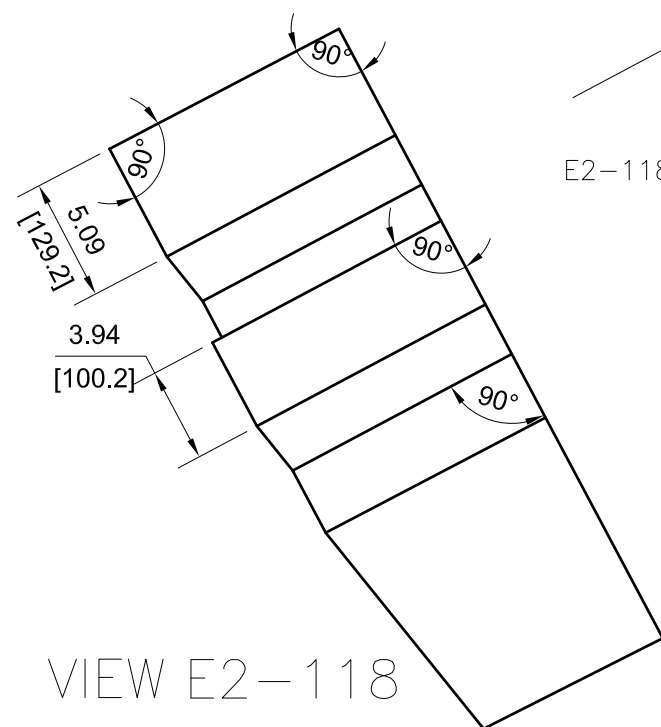

VIEW E2-118

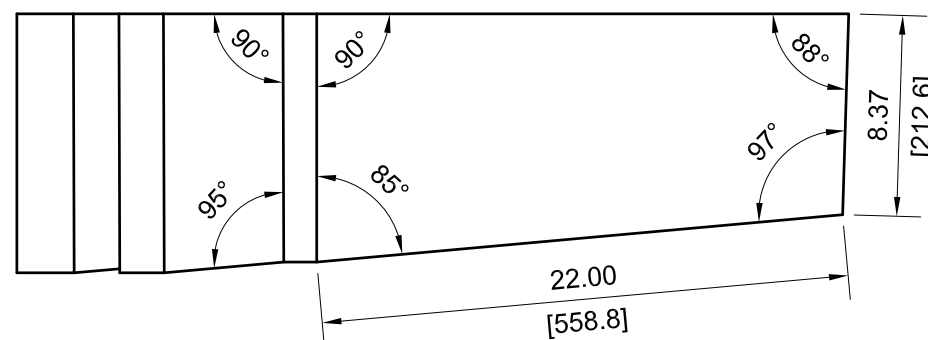

		DRAWING NUMBER			
		AES-D0008			
SIZE	SCALE	SHEET	OF	REVISION	
A3	NONE	118	190	B	

234

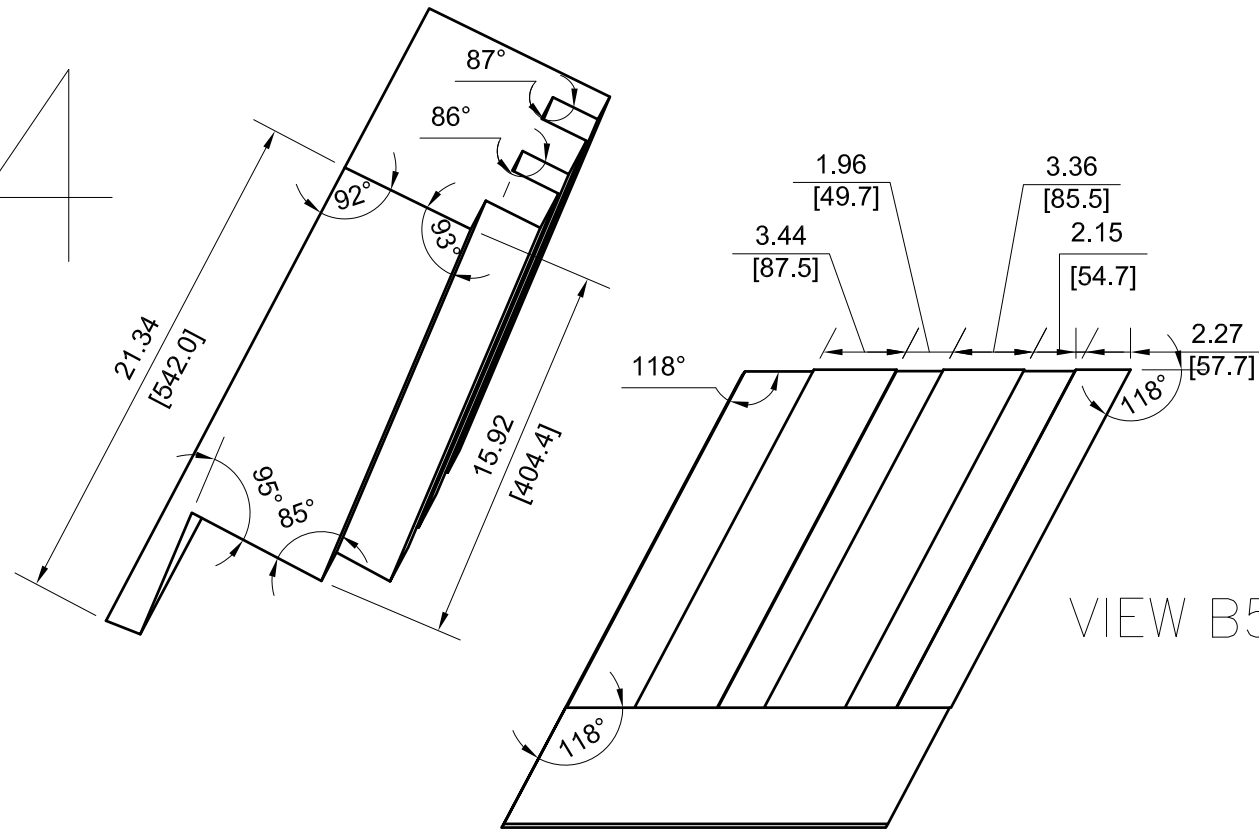

VIEW D3-119

VIEW B5-119

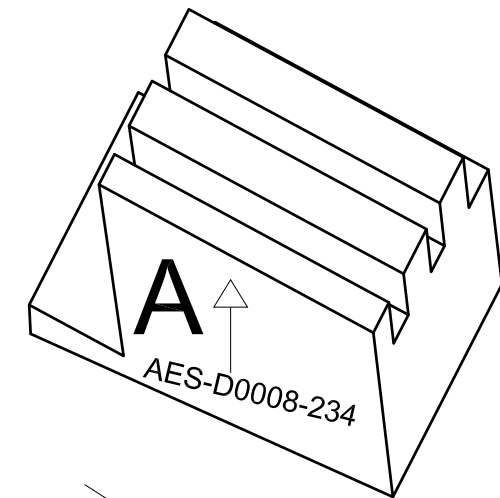

D3-119 C2-119

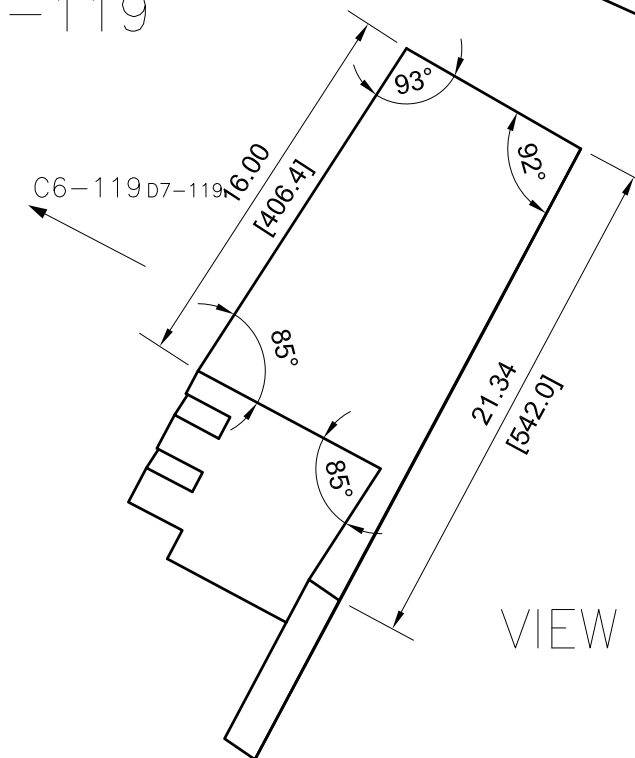
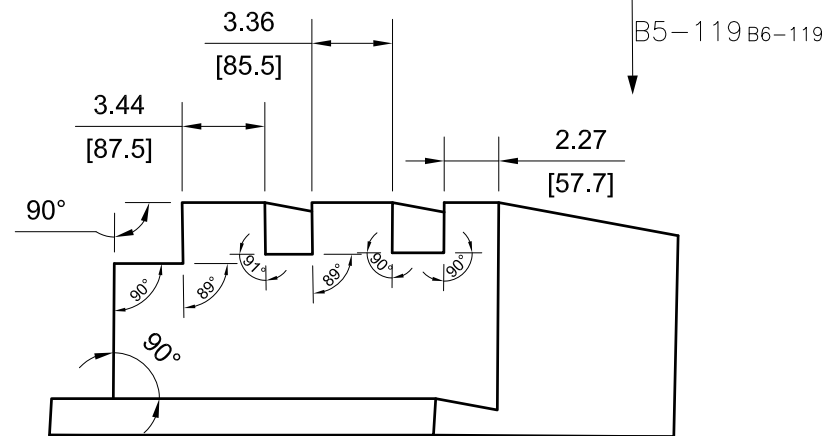

VIEW C6-119

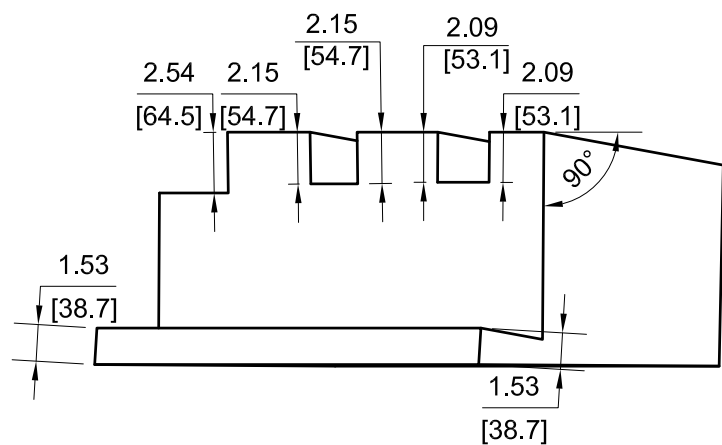

VIEW D4-119 REPEATED FOR CLARITY PURPOSES.

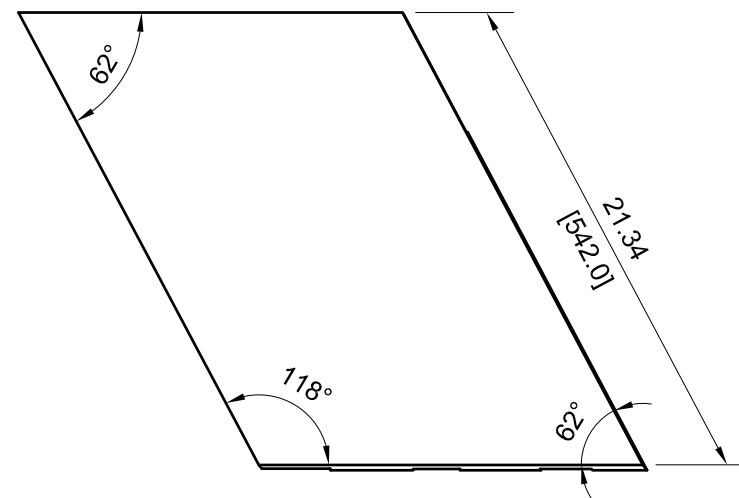

DRAWING NUMBER					AES-D0008	
SIZE	SCALE	SHEET	OF	REVISION		
A3	NONE	119	190	B		

236

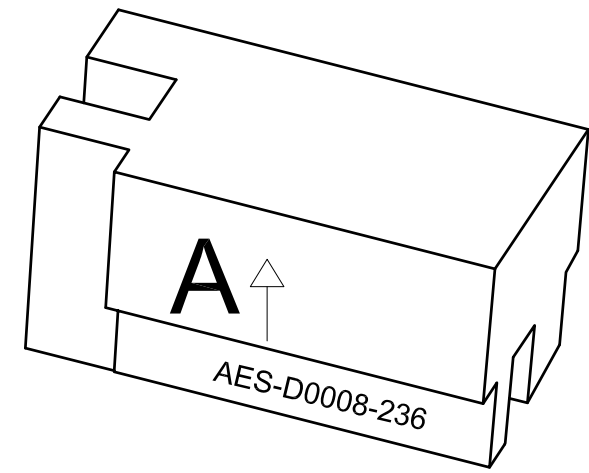

VIEW B3-120

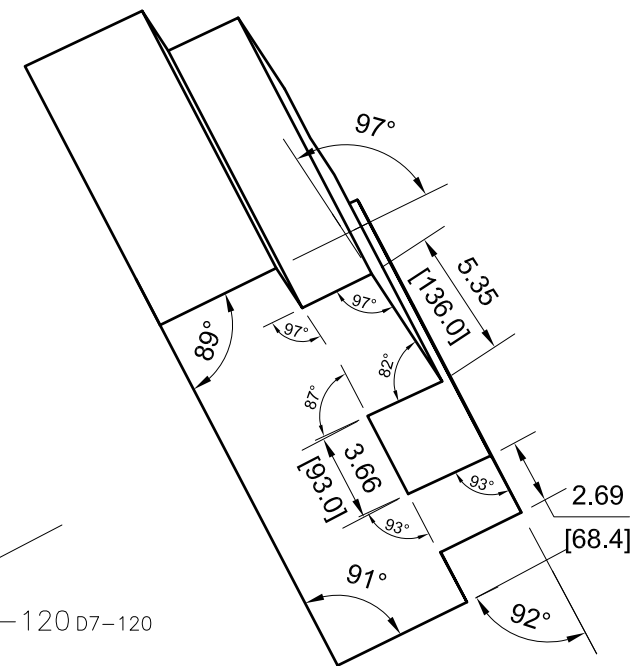
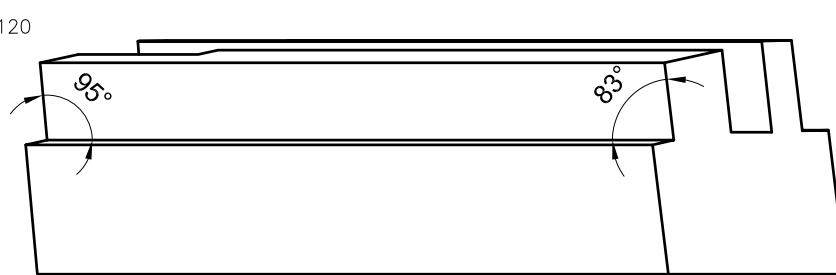

VIEW D6-120

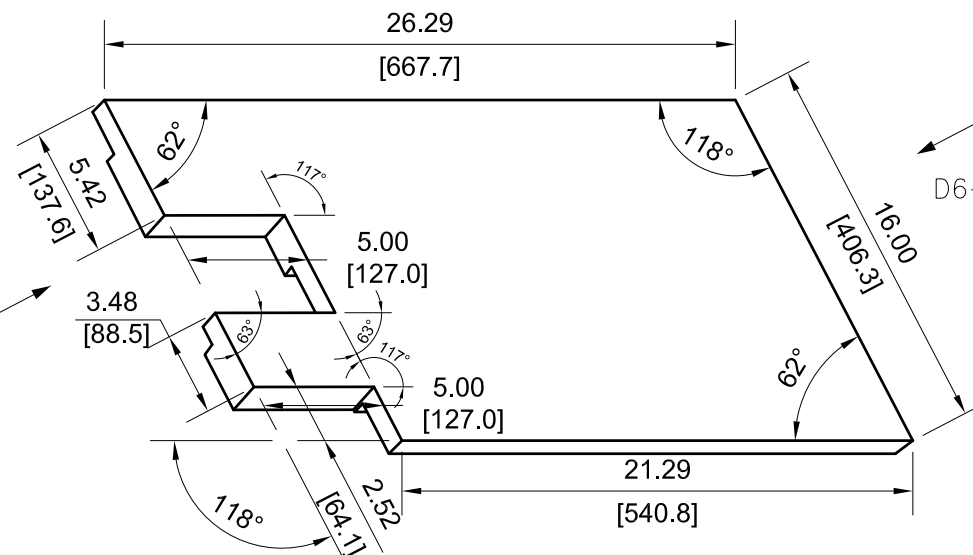

D3-120 F1-120

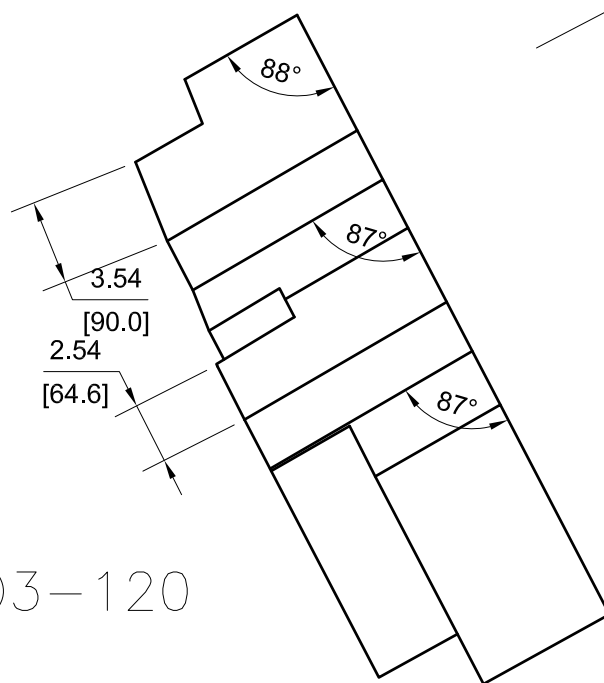

VIEW D3-120

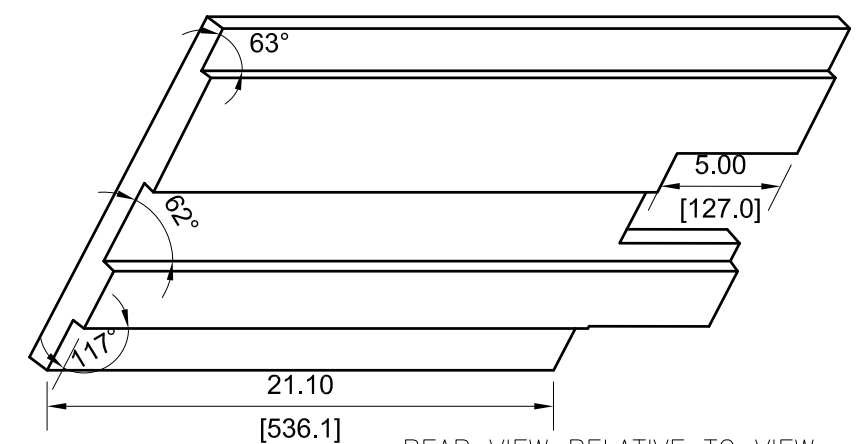
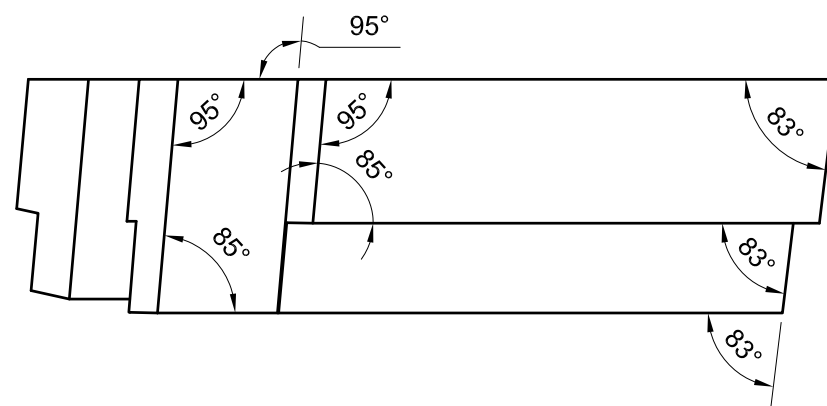

REAR VIEW RELATIVE TO VIEW D4-120



DRAWING NUMBER				
AES-D0008				
SIZE	SCALE	SHEET	OF	REVISION
A3	NONE	120	190	B

238

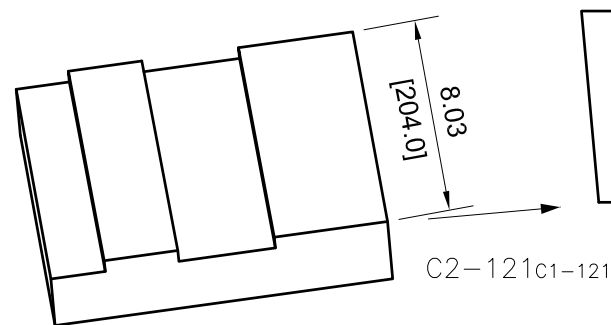
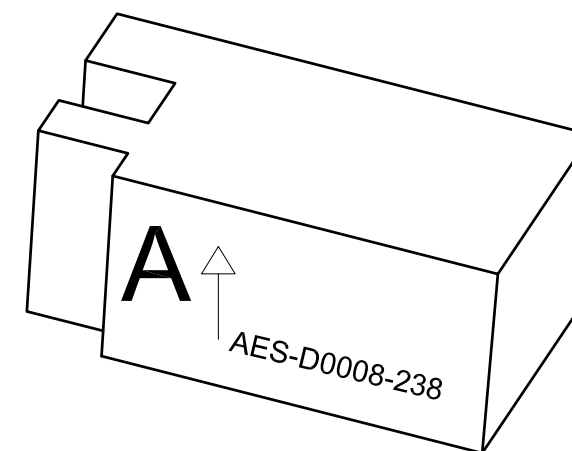

VIEW C2-121

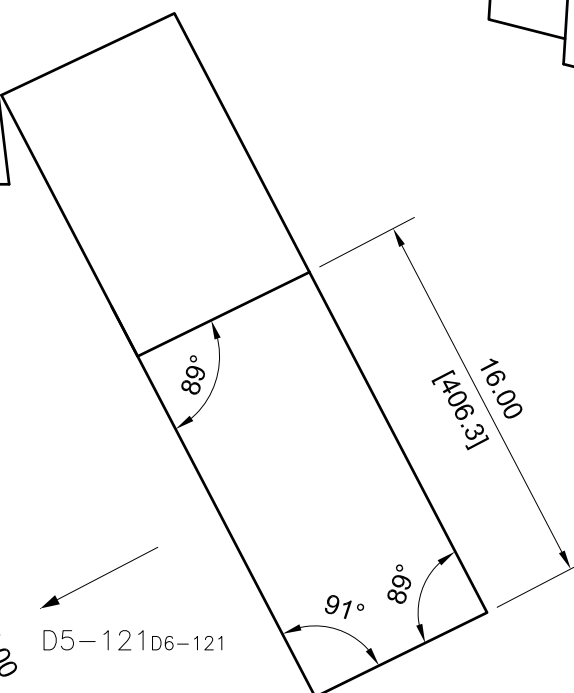

VIEW D5-121

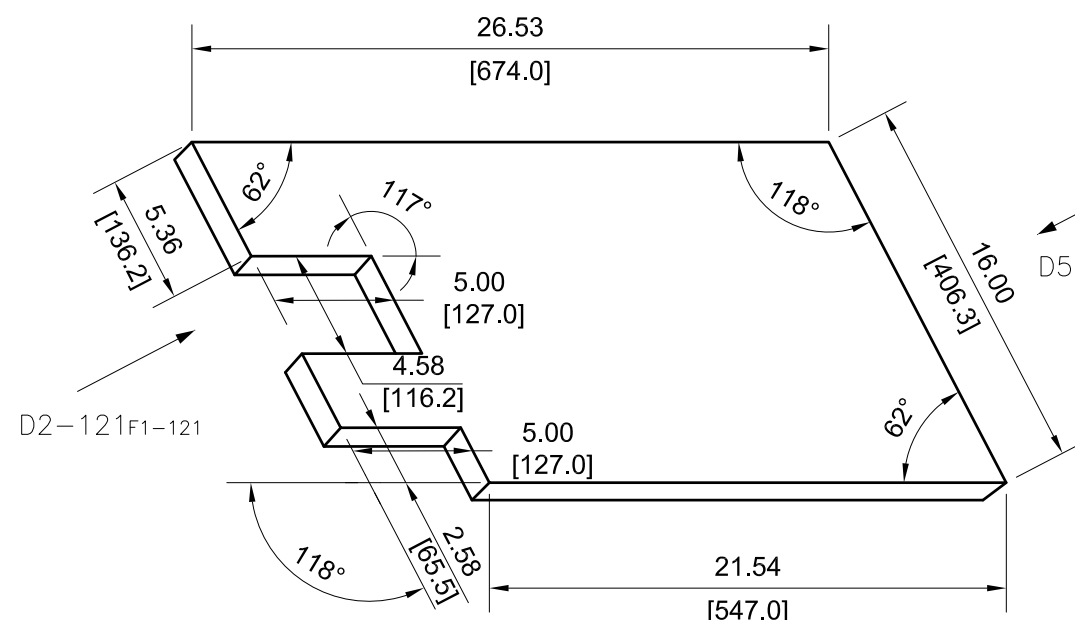

D2-121f1-121

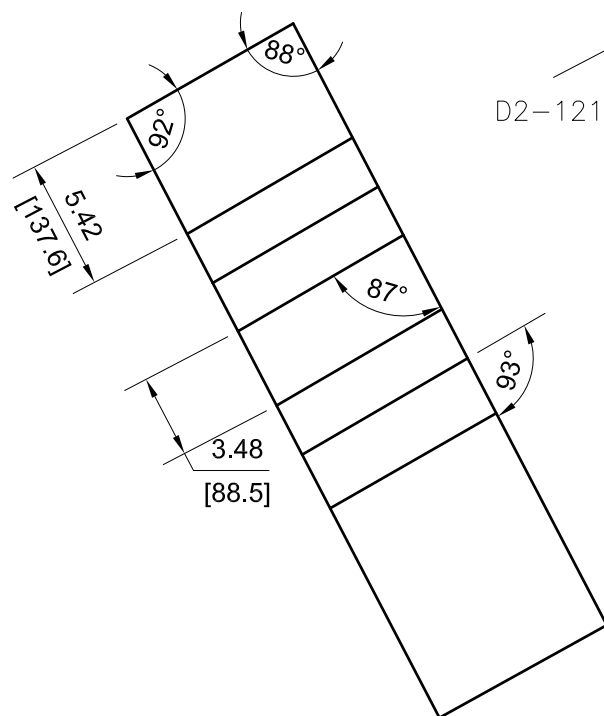

VIEW D2-121

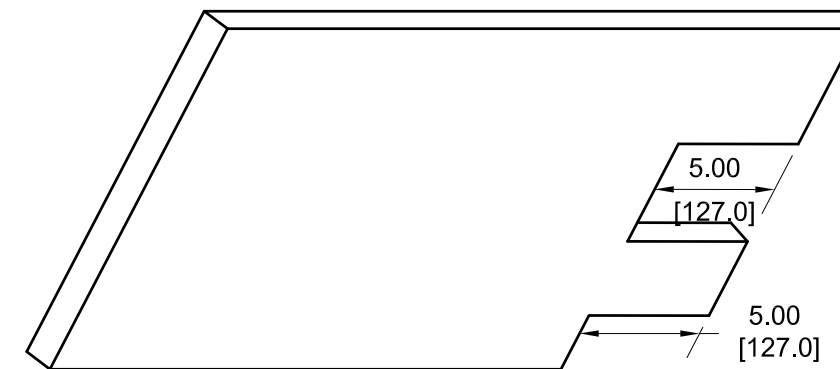
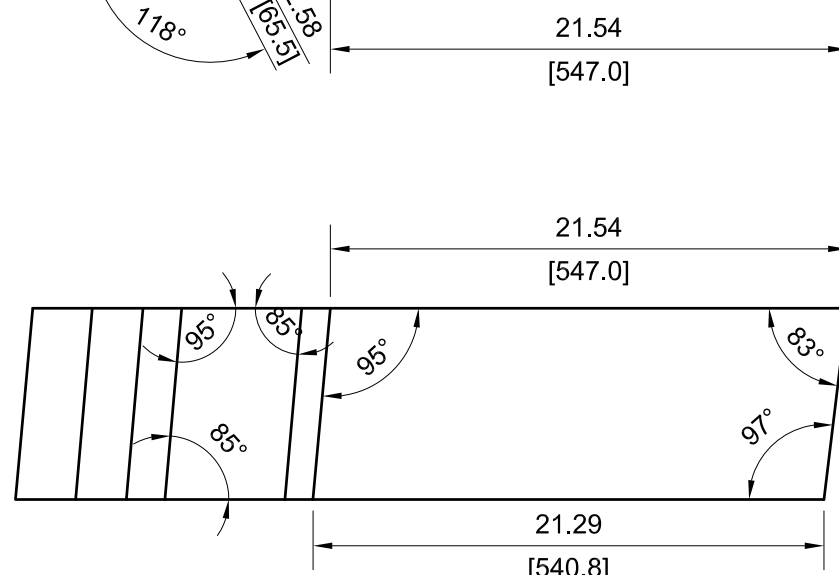

REAR VIEW RELATIVE TO VIEW D4-121



DRAWING NUMBER					AES-D0008	
SIZE	SCALE	SHEET	OF	REVISION		
A3	NONE	121	190	B		

— 240

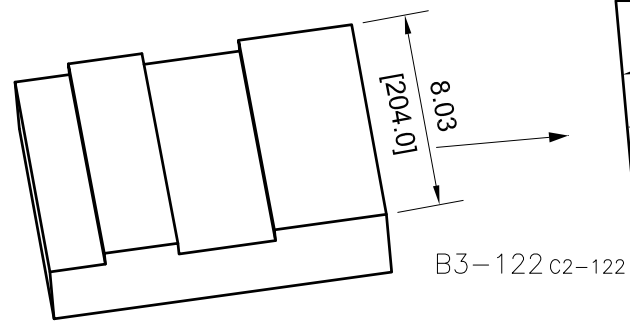

B3-122 c2-122

VIEW B3-122

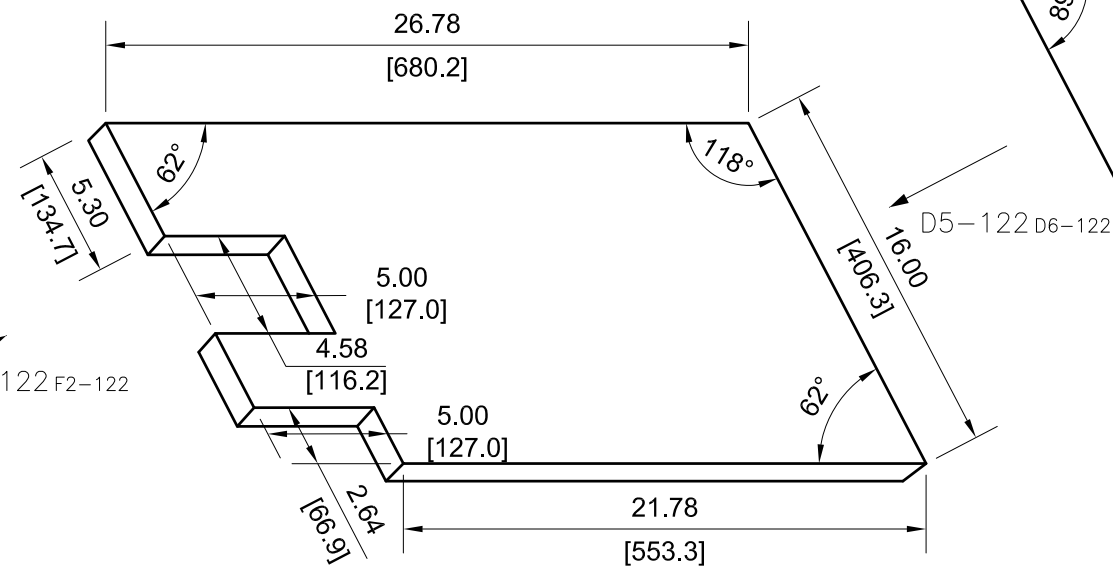
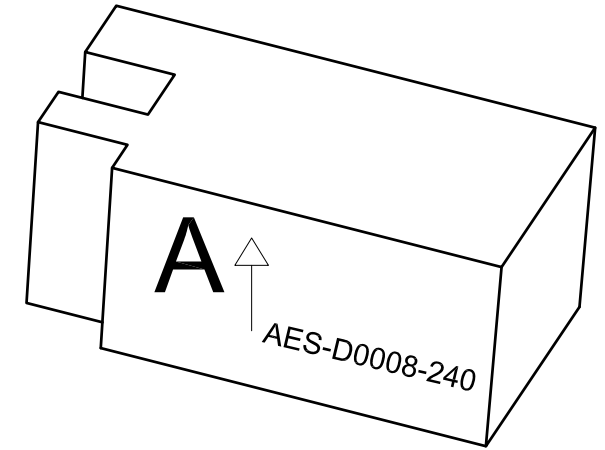
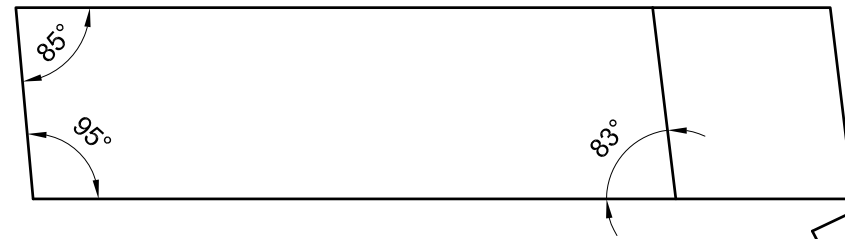

D3-122 F2-122

VIEW D5-122

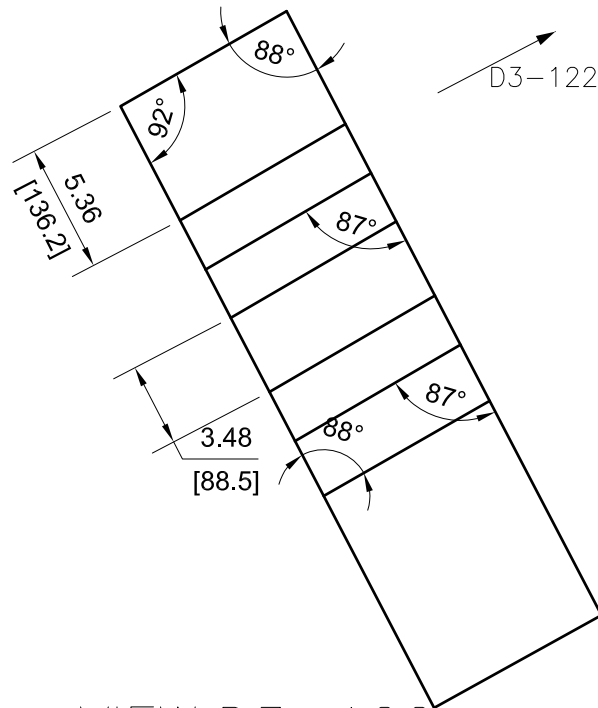

VIEW D3-122

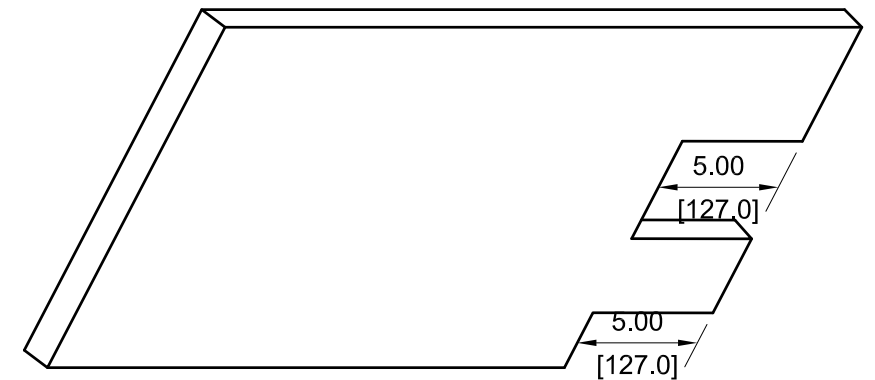
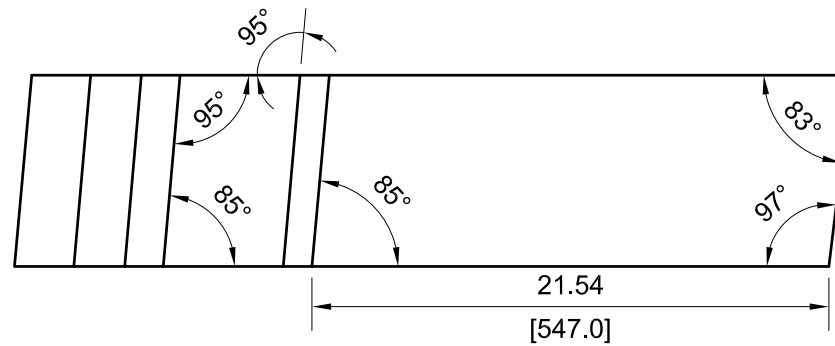

REAR VIEW RELATIVE TO VIEW D4-122



DRAWING NUMBER				
AES-D0008				
SIZE	SCALE	SHEET	OF	REVISION
A3	NONE	122	190	B

— 242

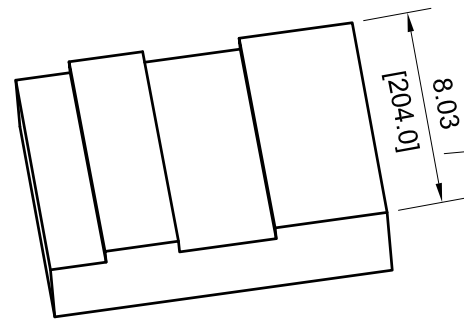

VIEW B3-123

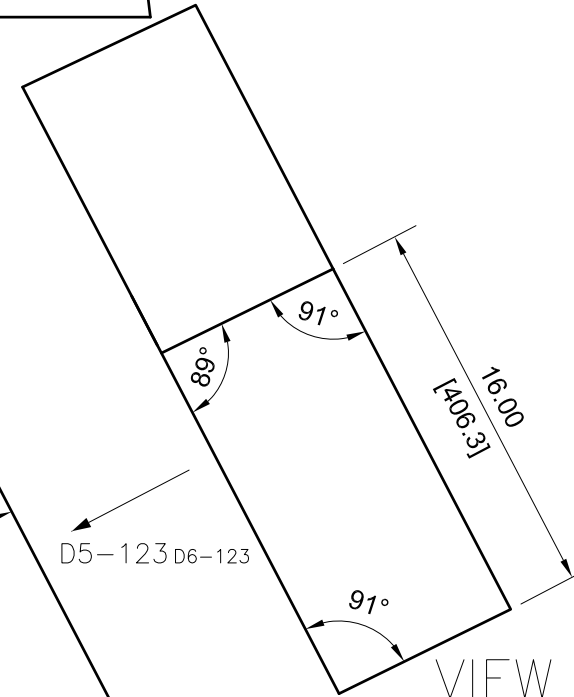
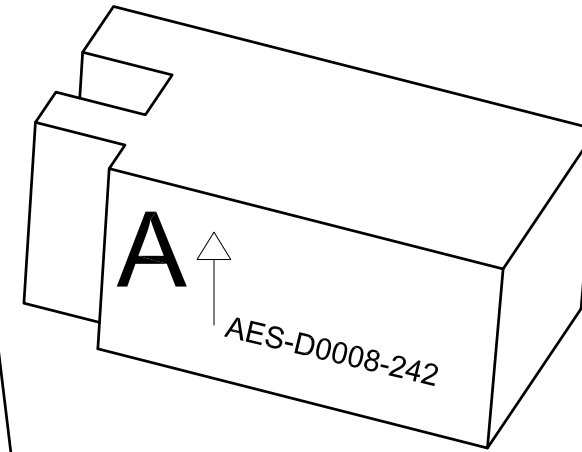
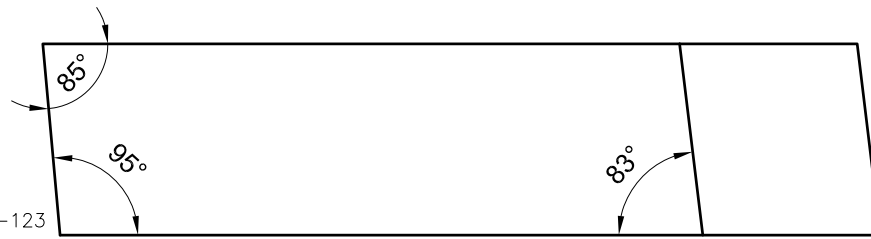

VIEW D5-123

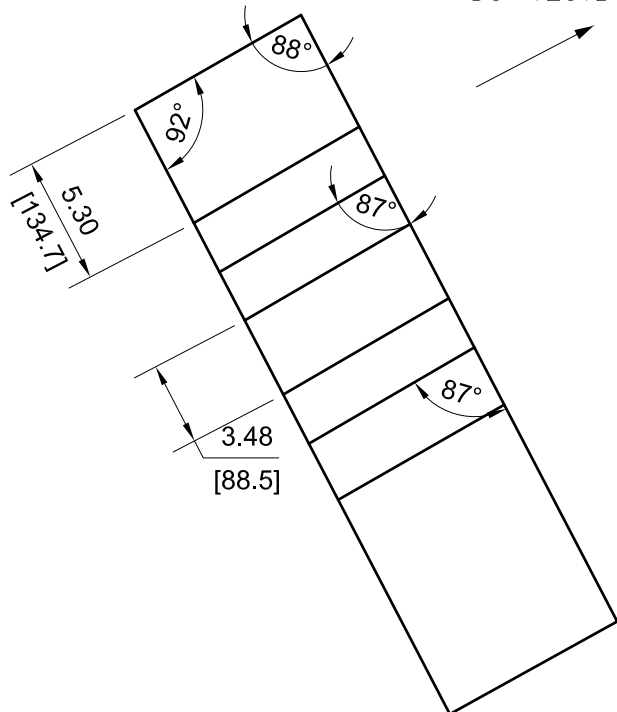
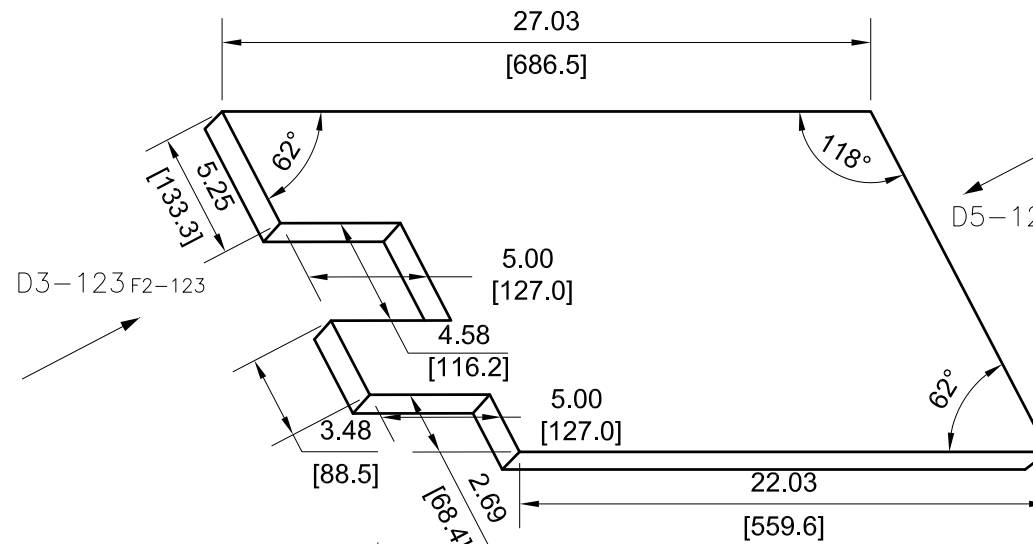

VIEW D3-123

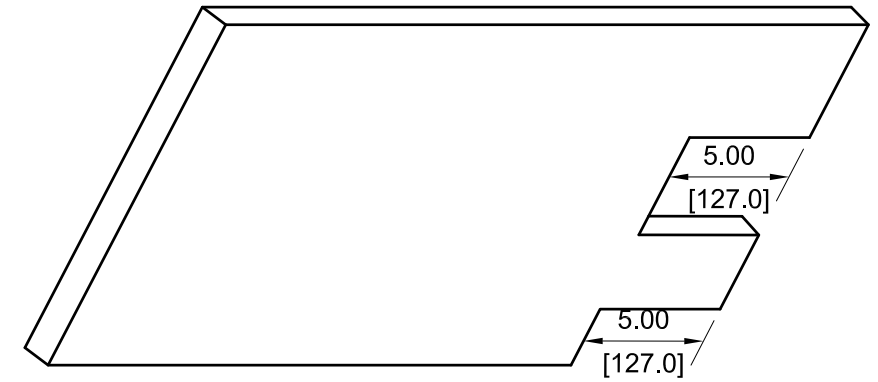
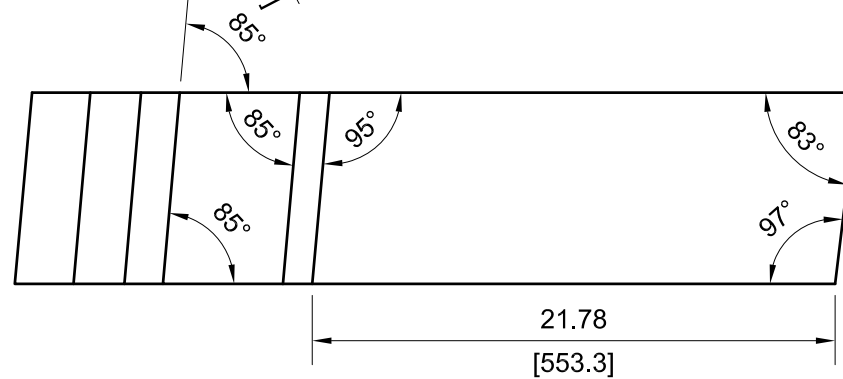

REAR VIEW RELATIVE TO VIEW D4-123



DRAWING NUMBER				
AES-D0008				
SIZE	SCALE	SHEET	OF	REVISION
A3	NONE	123	190	B

— 244

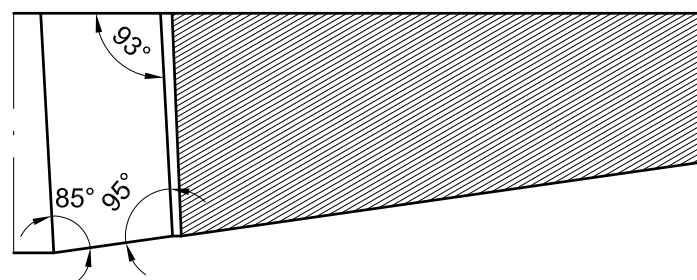
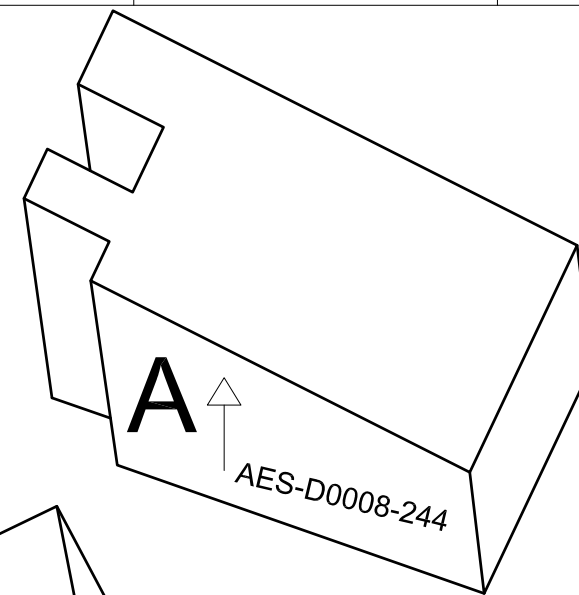

SECTION VIEW D4-124

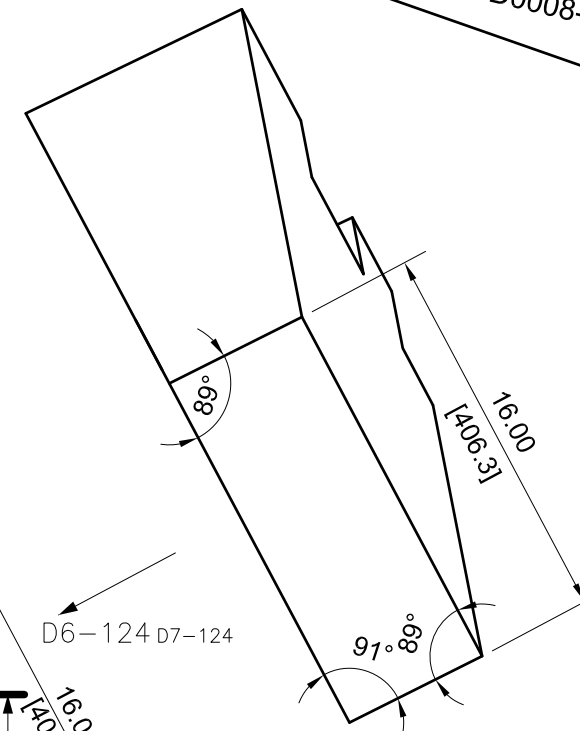

VIEW D6-124

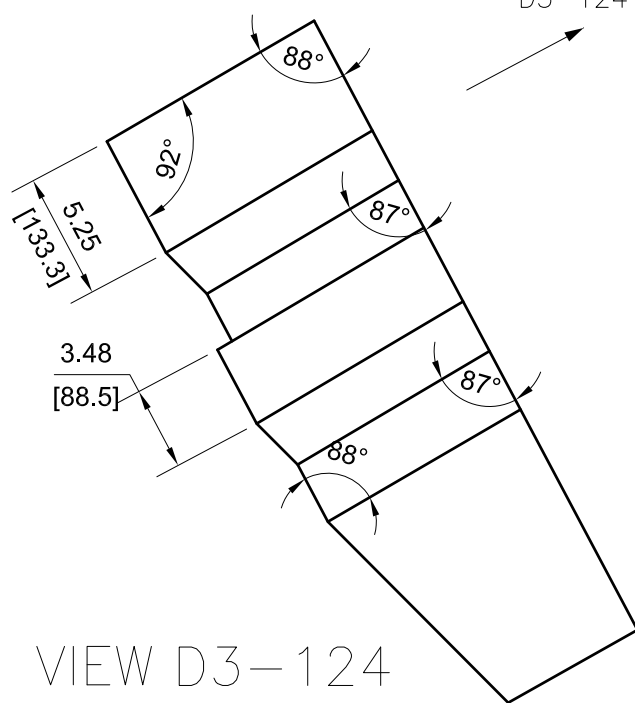
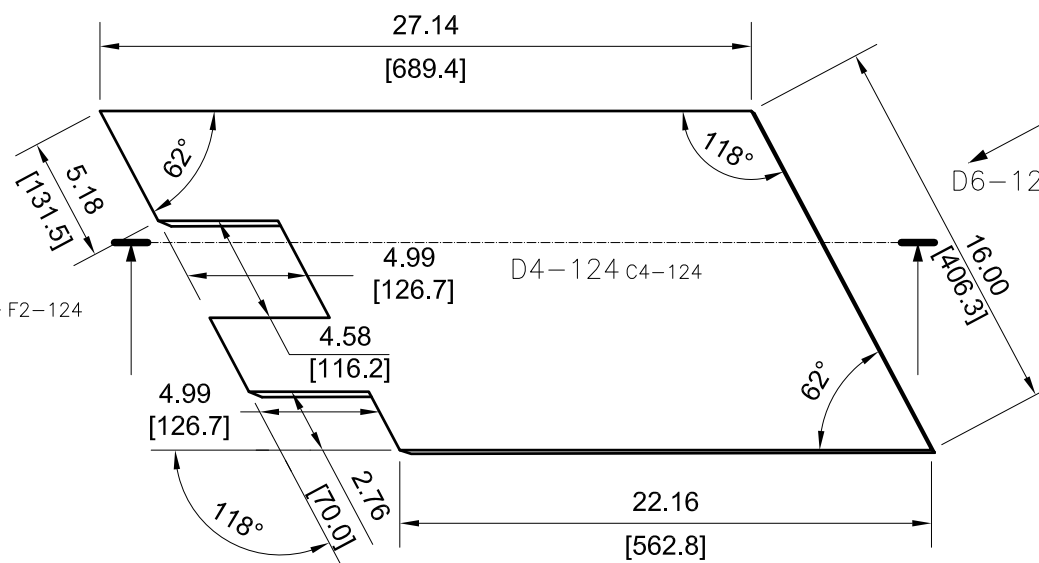

VIEW D3-124

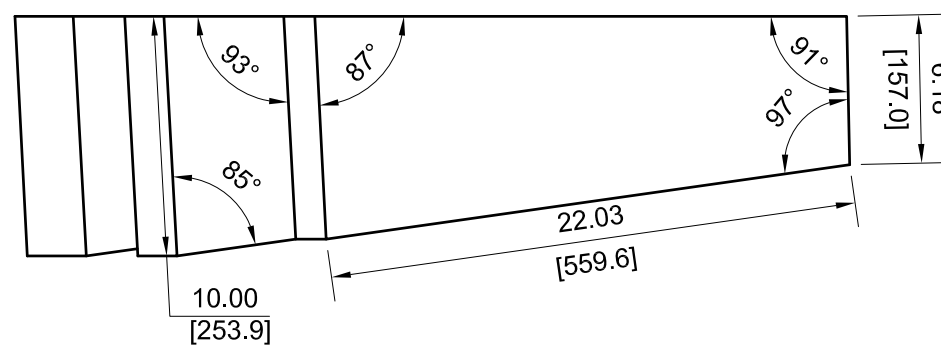

		DRAWING NUMBER			
		AES-D0008			
SIZE	SCALE	SHEET	OF	REVISION	
A3	NONE	124	190	B	

246

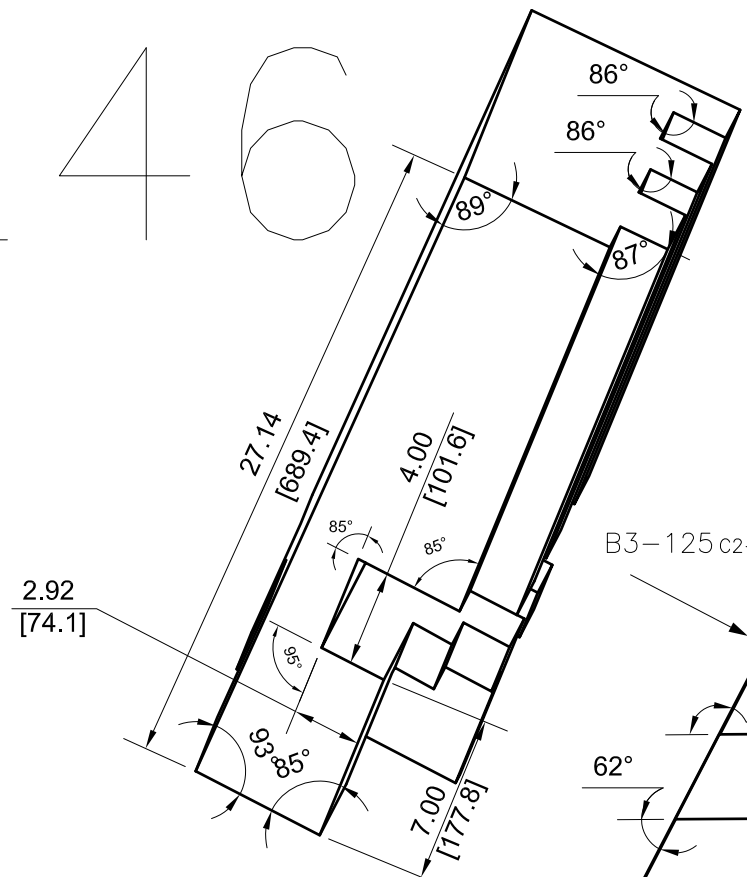

VIEW B3-125

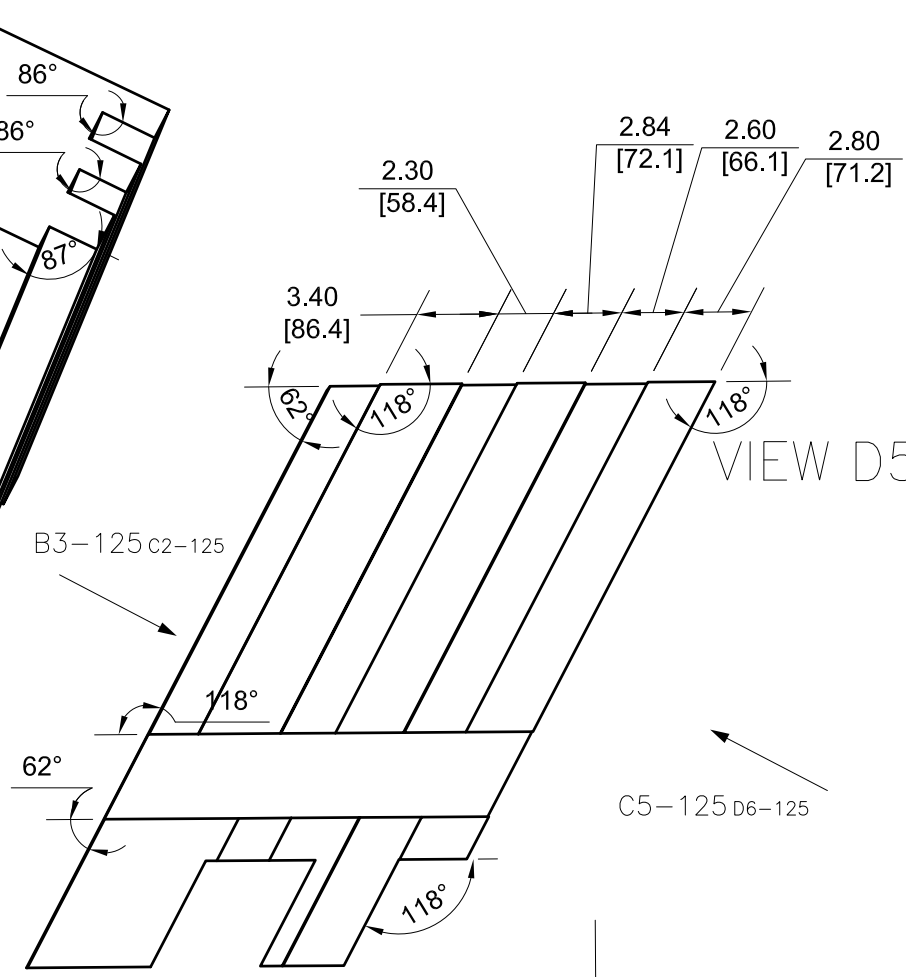

VIEW D5-125

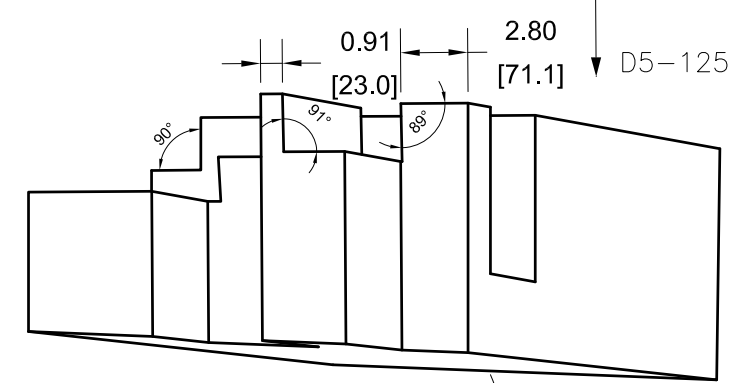
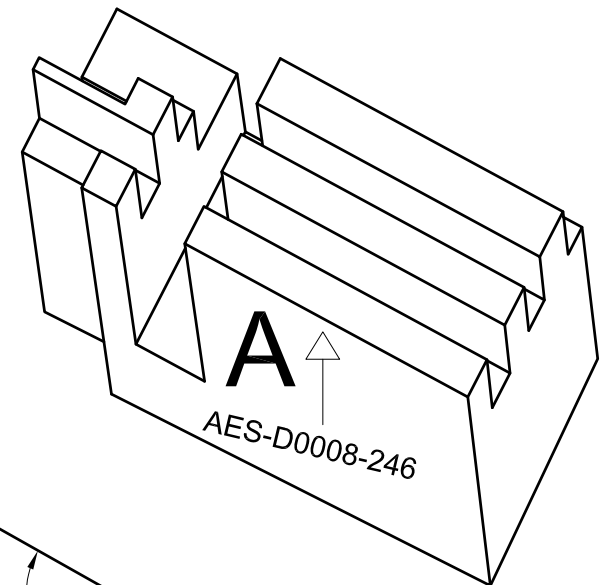

VIEW C5-125

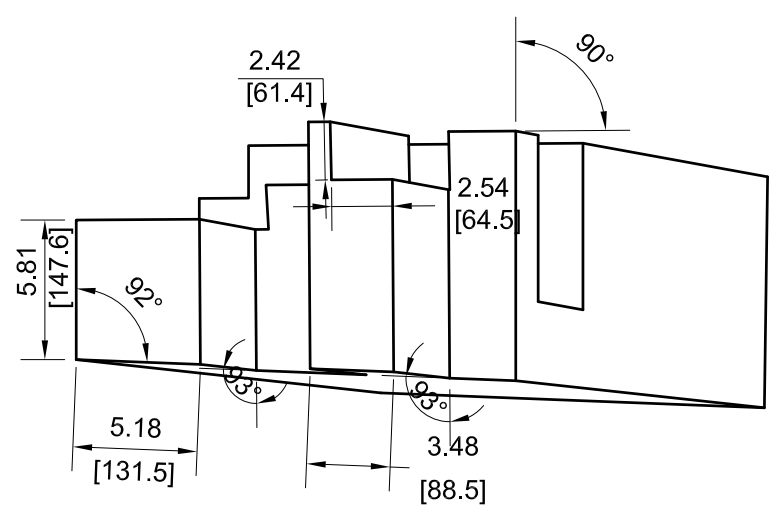

VIEW D4-125 REPEATED FOR CLARITY PURPOSES.

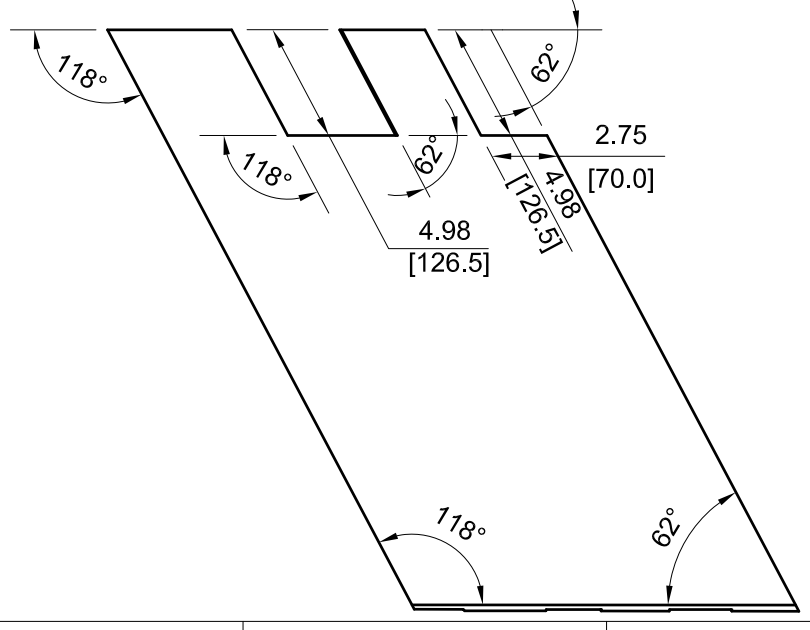

		DRAWING NUMBER			
		AES-D0008			
SIZE	SCALE	SHEET	OF	REVISION	
A3	NONE	125	190	B	

248

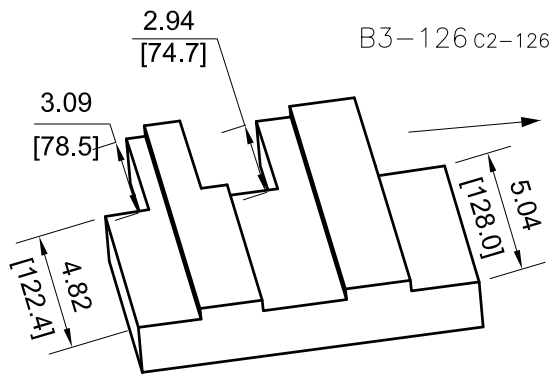

VIEW B3-126

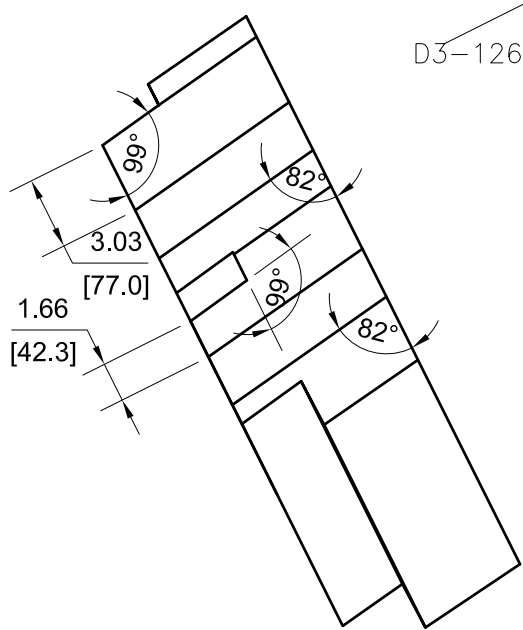
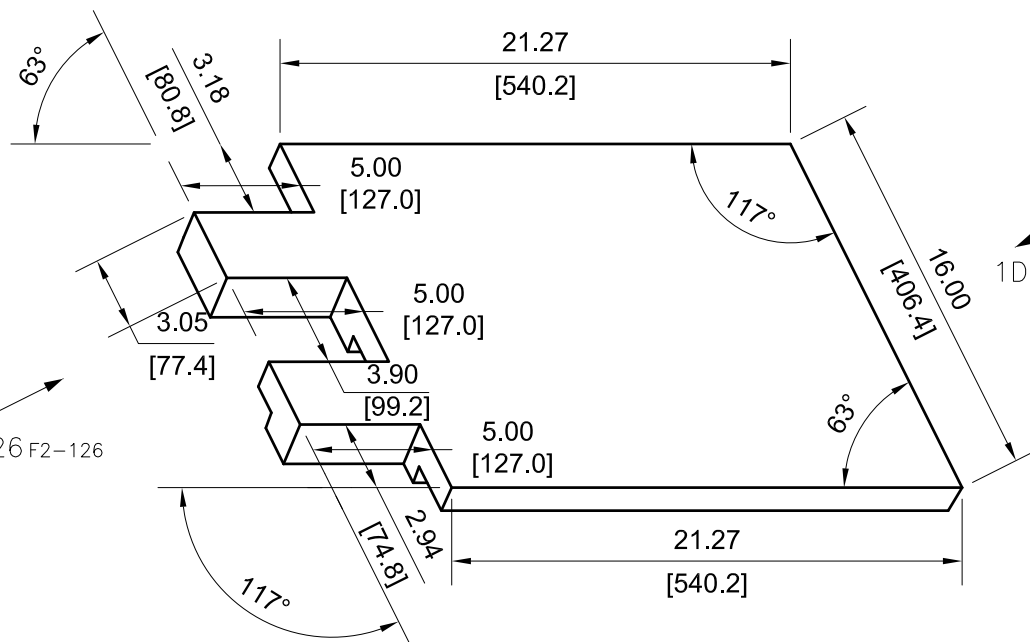
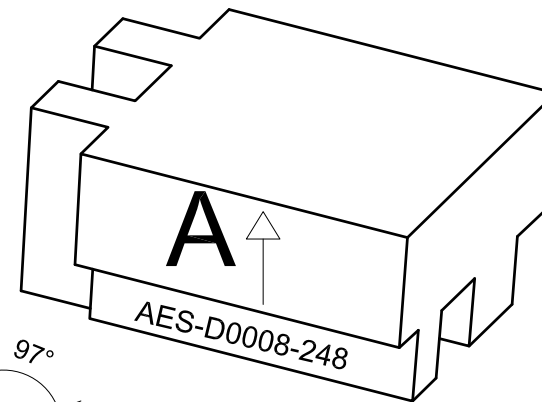
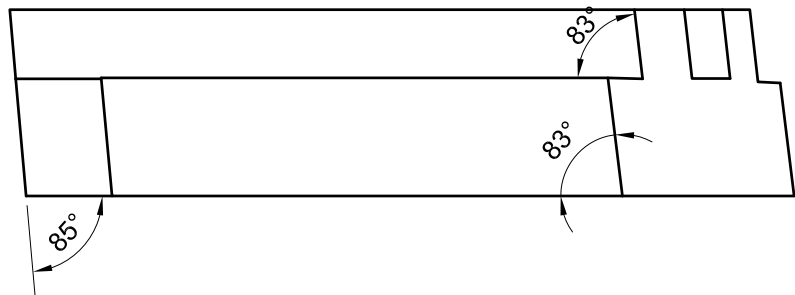

VIEW D3-126

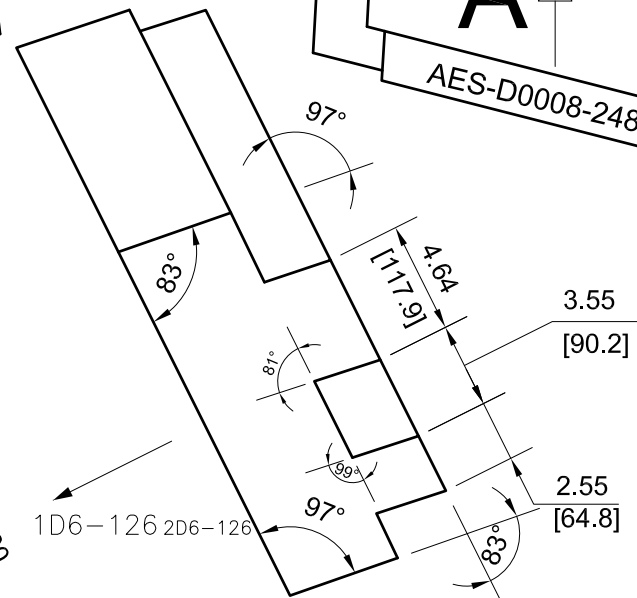
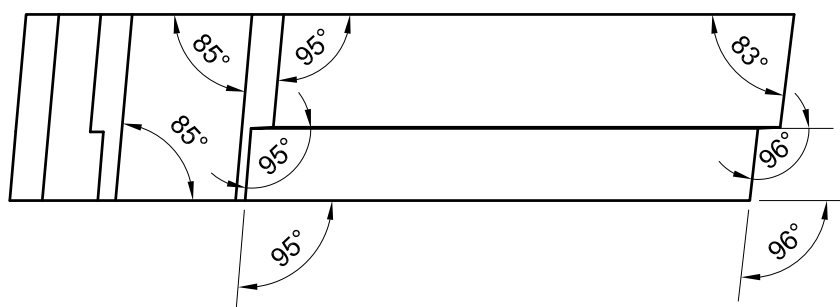

VIEW 1D6-126

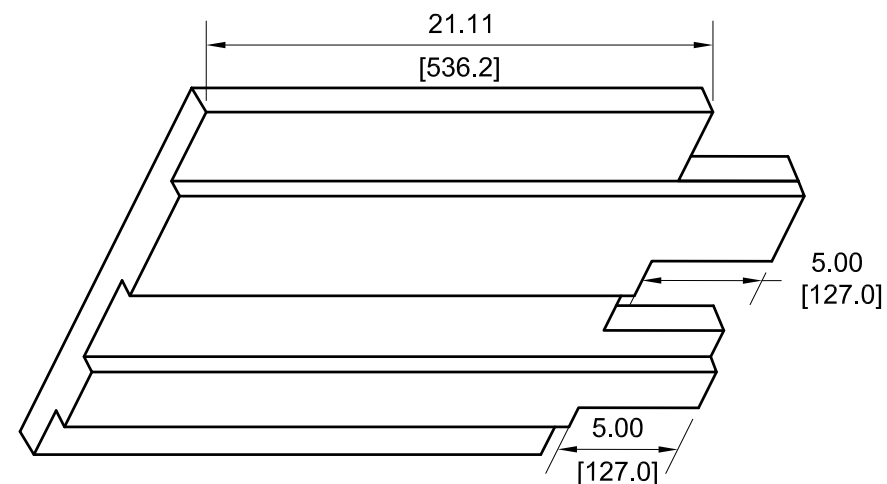

REAR VIEW RELATIVE TO VIEW D4-126



DRAWING NUMBER				
AES-D0008				
SIZE	SCALE	SHEET	OF	REVISION
A3	NONE	126	190	B

250

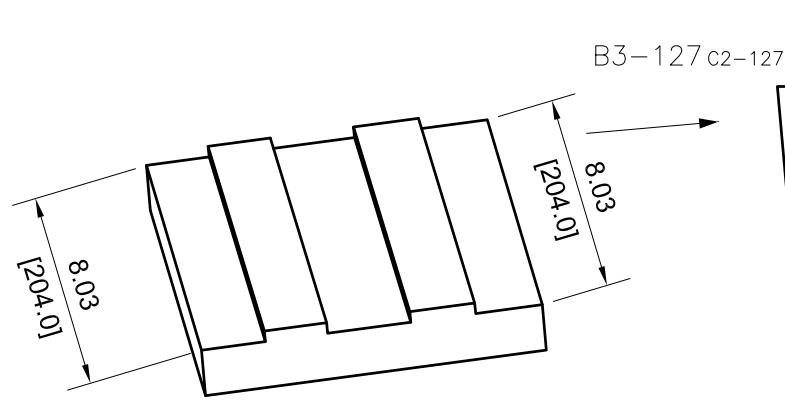

VIEW B3-127

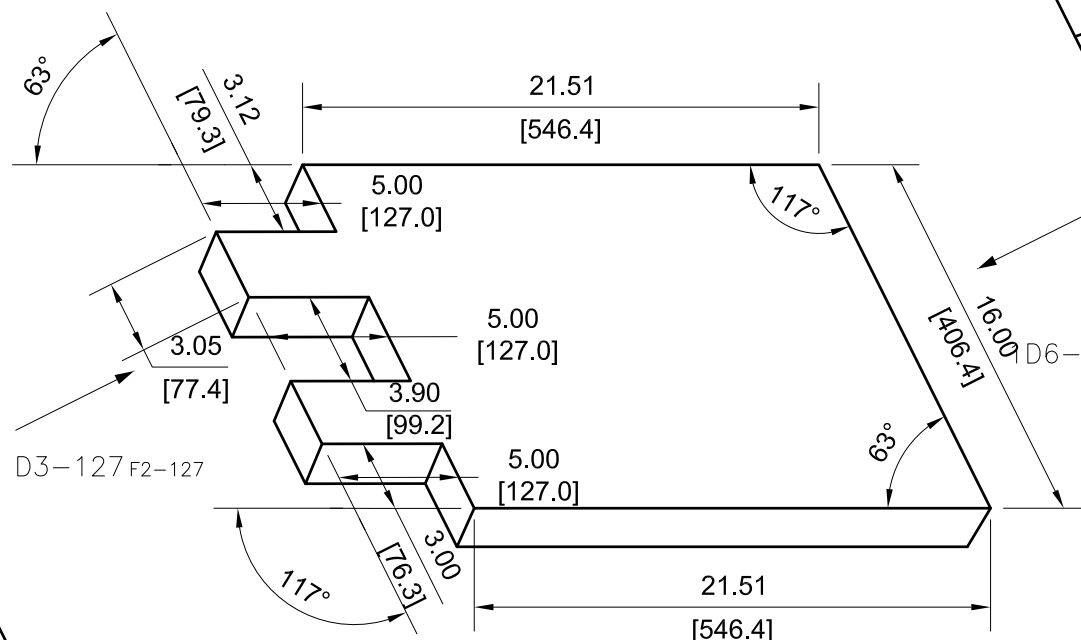
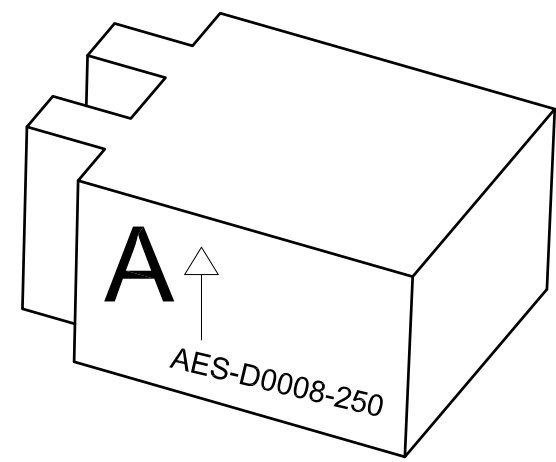
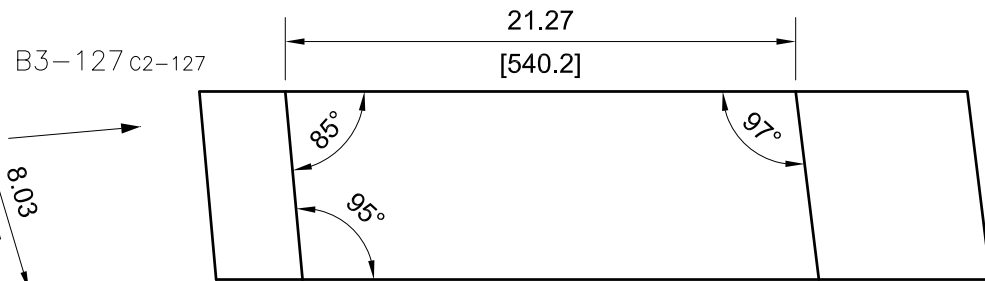

VIEW 1D6-127

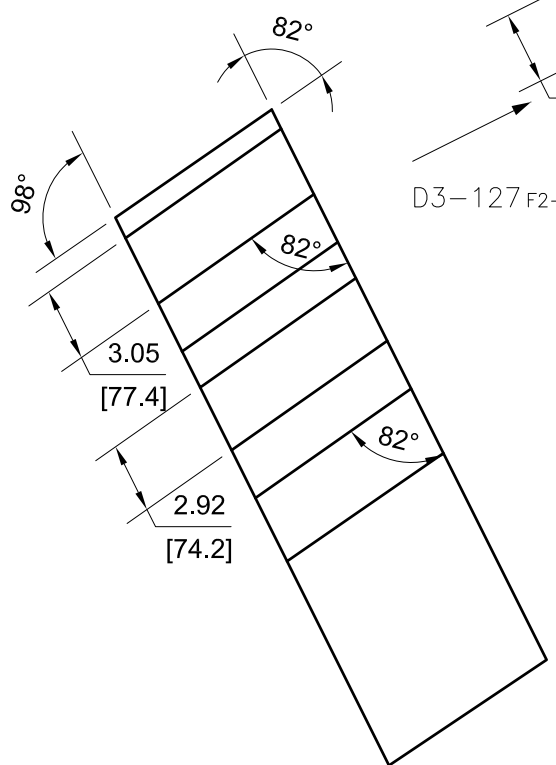

VIEW D3-127

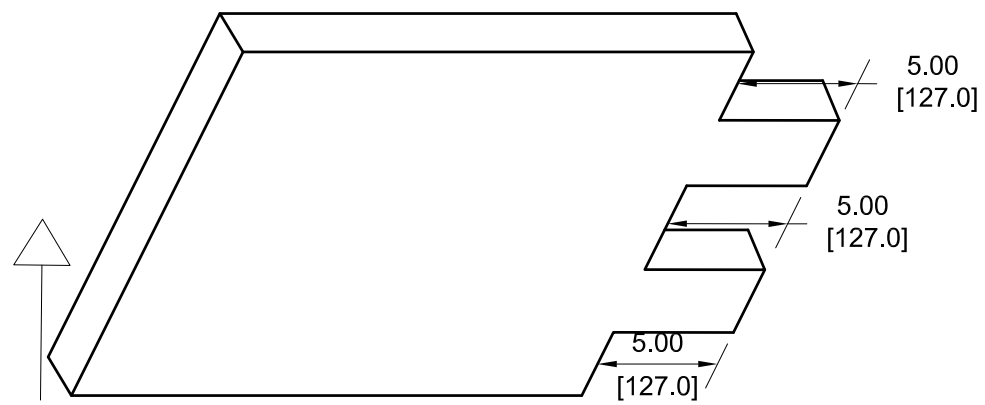
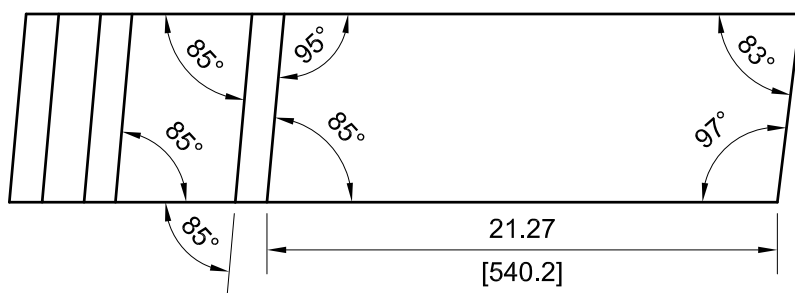

REAR VIEW RELATIVE TO VIEW D4-127

UP
1



DRAWING NUMBER				
AES-D0008				
SIZE	SCALE	SHEET	OF	REVISION
A3	NONE	127	190	B

252

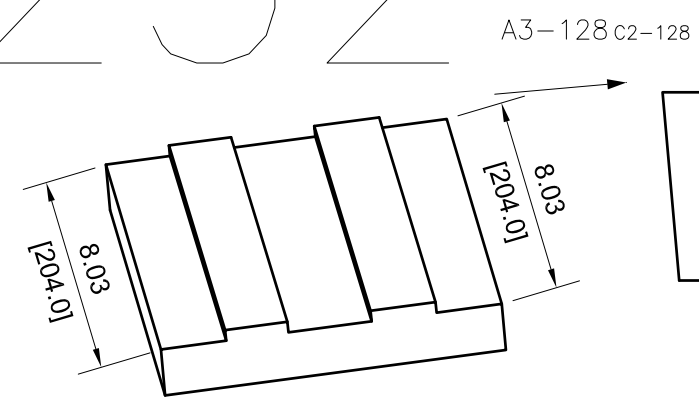

VIEW A3-128

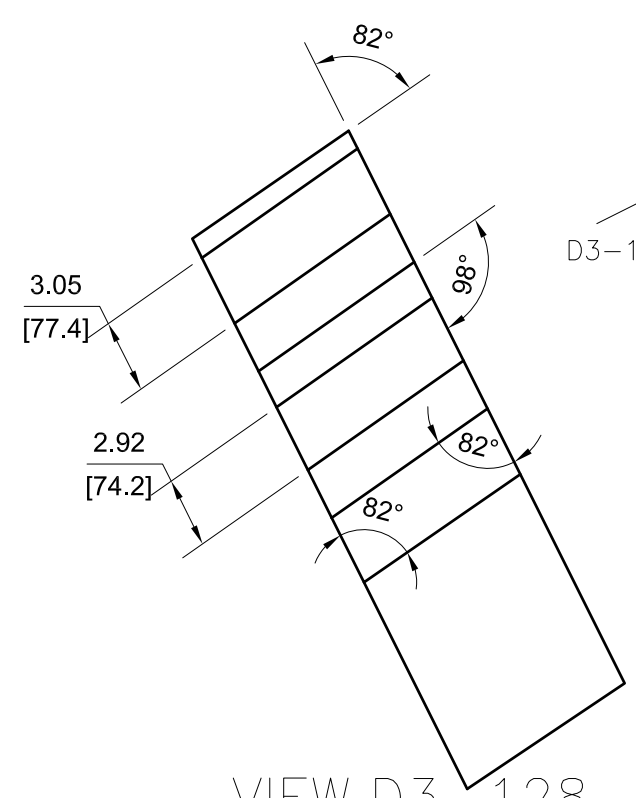
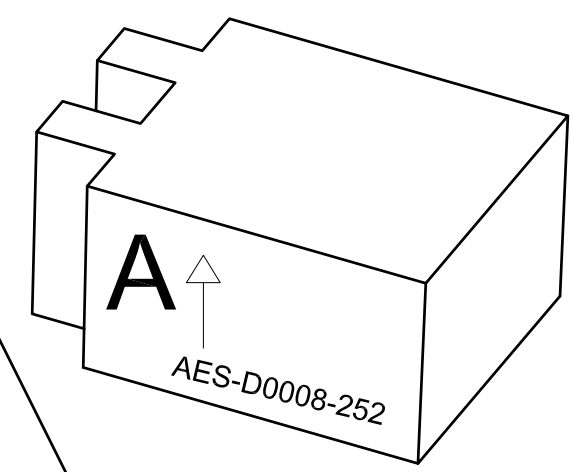

VIEW D3-128

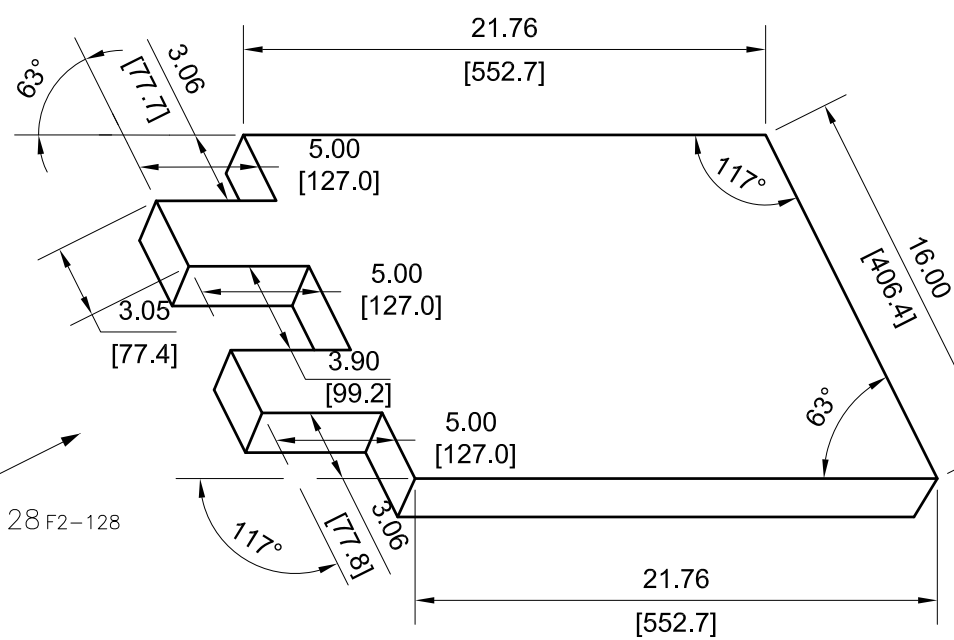

VIEW 1D6-128

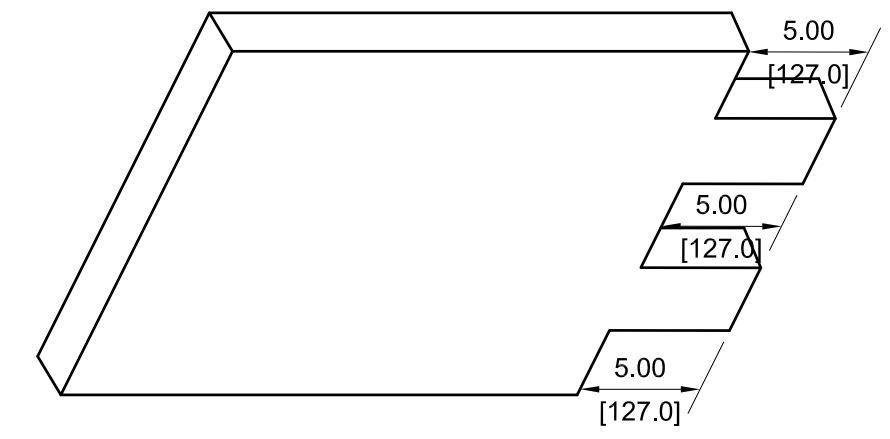
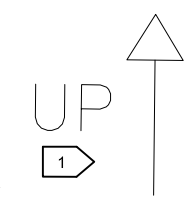
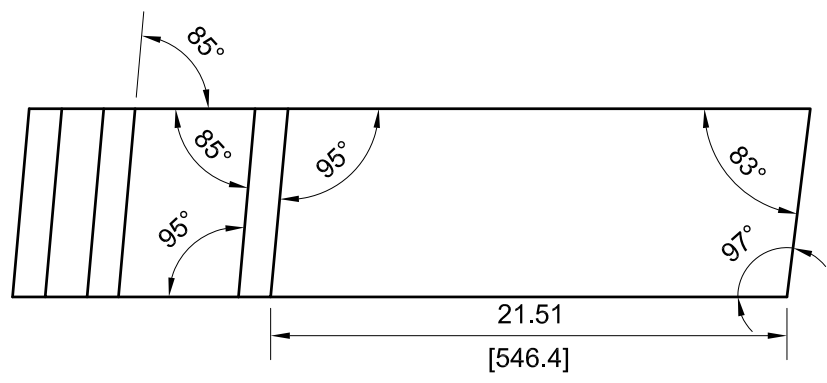

REAR VIEW RELATIVE TO VIEW D4-128



DRAWING NUMBER					AES-D0008	
SIZE	SCALE	SHEET	OF	REVISION		
A3	NONE	128	190	B		

254

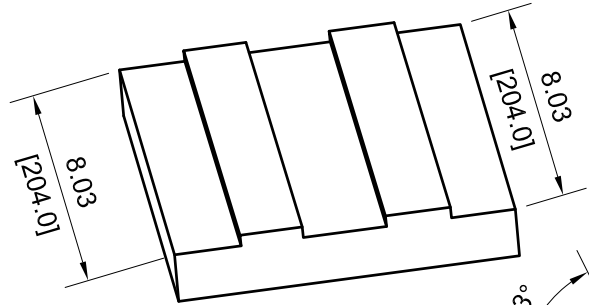

A3-129 C2-129

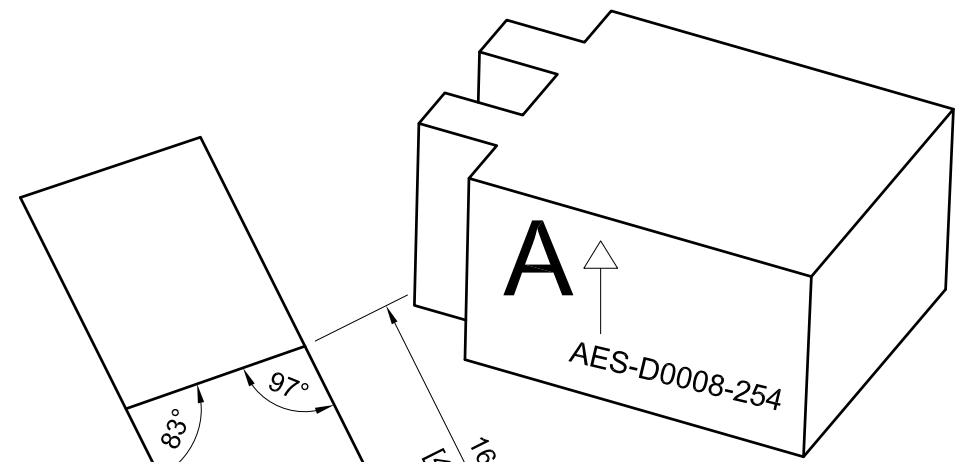
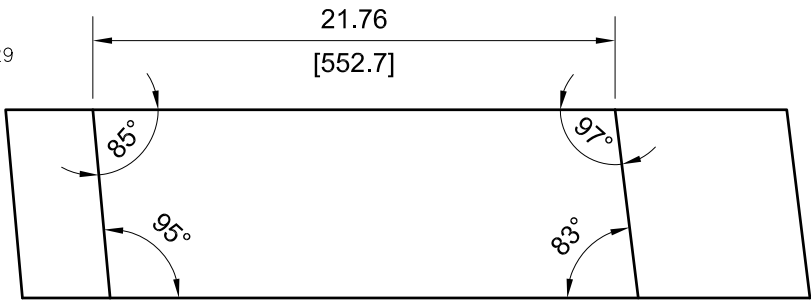

VIEW A3-129

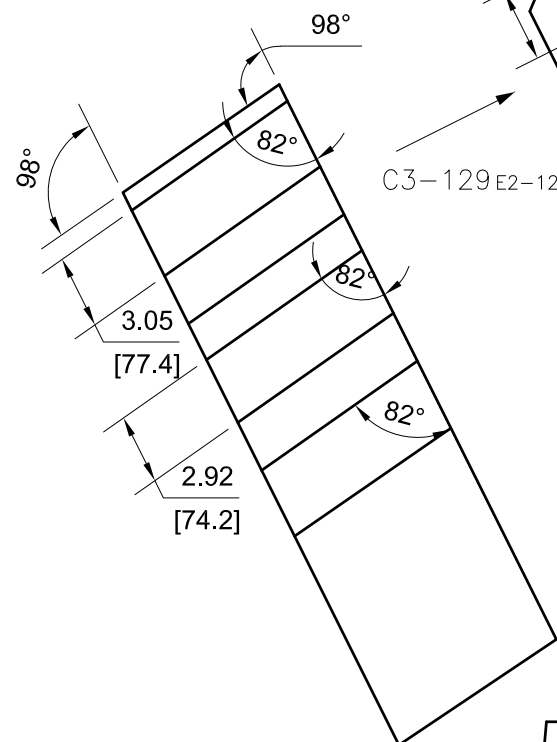

VIEW C3-129

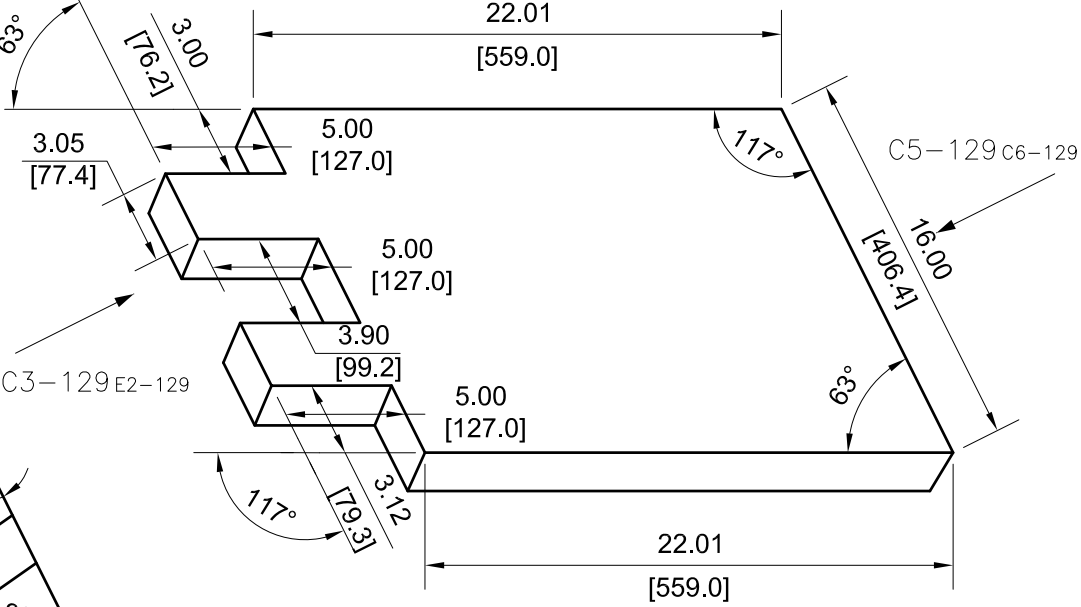

VIEW C5-129

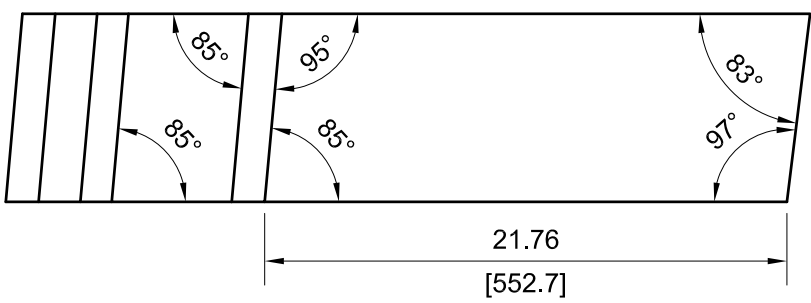
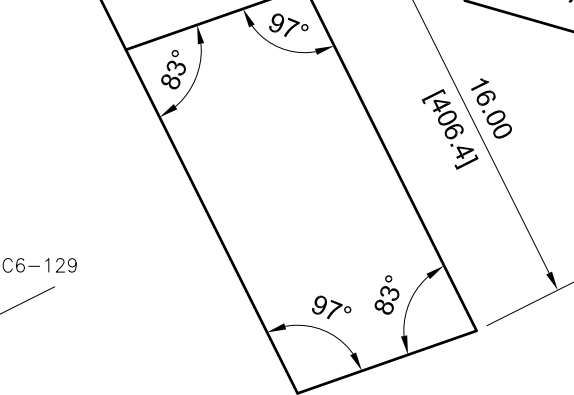

UP ↑

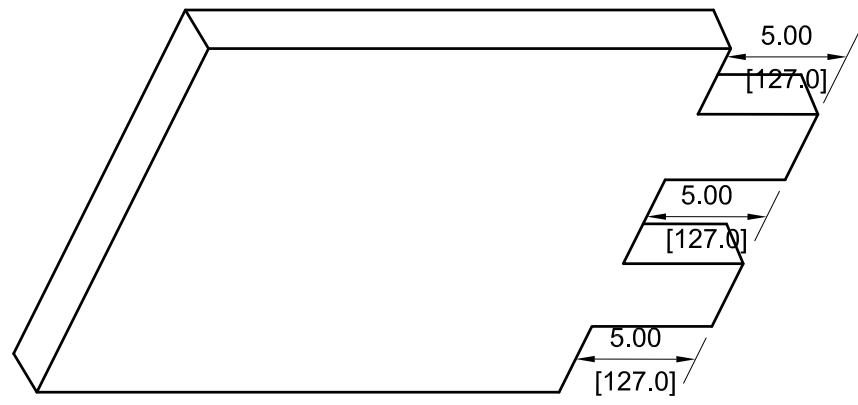

REAR VIEW RELATIVE TO VIEW D4-129



DRAWING NUMBER					AES-D0008	
SIZE	SCALE	SHEET	OF	REVISION		
A3	NONE	129	190	B		

— 256

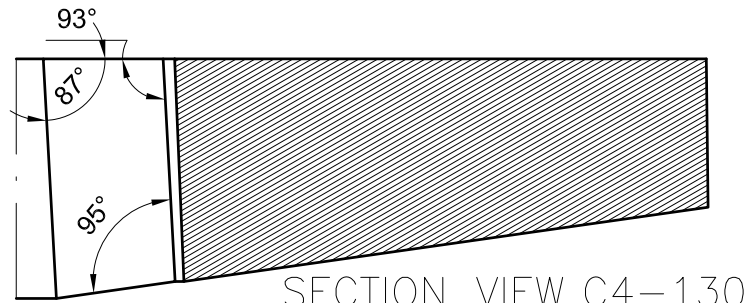

SECTION VIEW C4-130

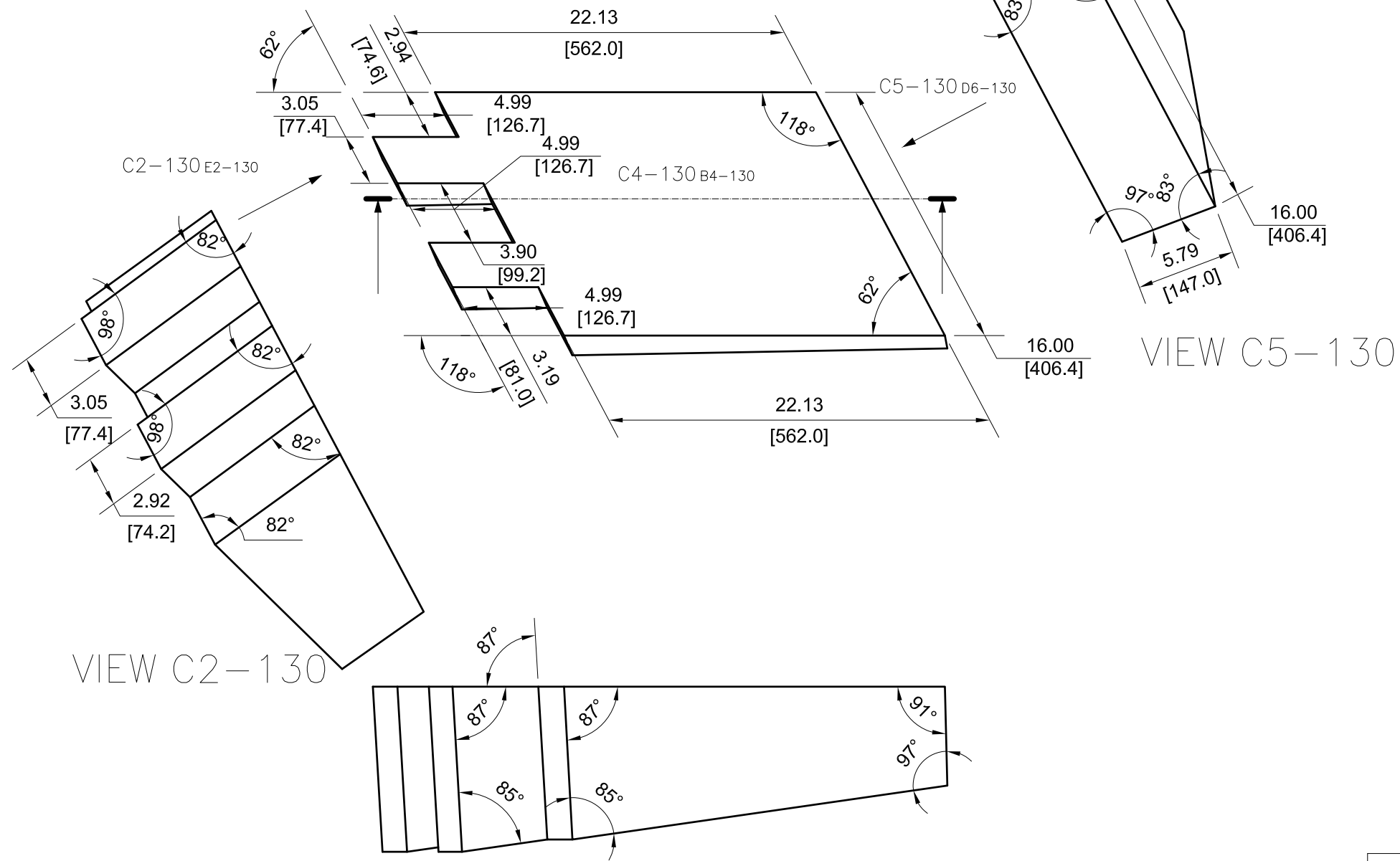
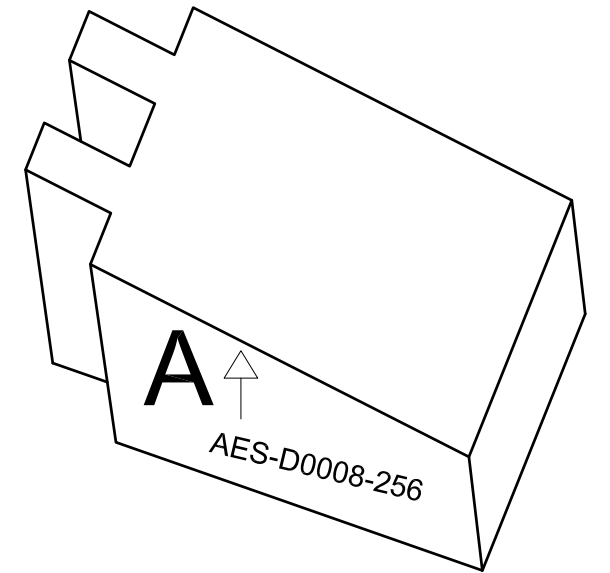

VIEW C2-130

VIEW C5-130



DRAWING NUMBER				
AES-D0008				
SIZE	SCALE	SHEET	OF	REVISION
A3	NONE	130	190	B

258

VIEW B4-131

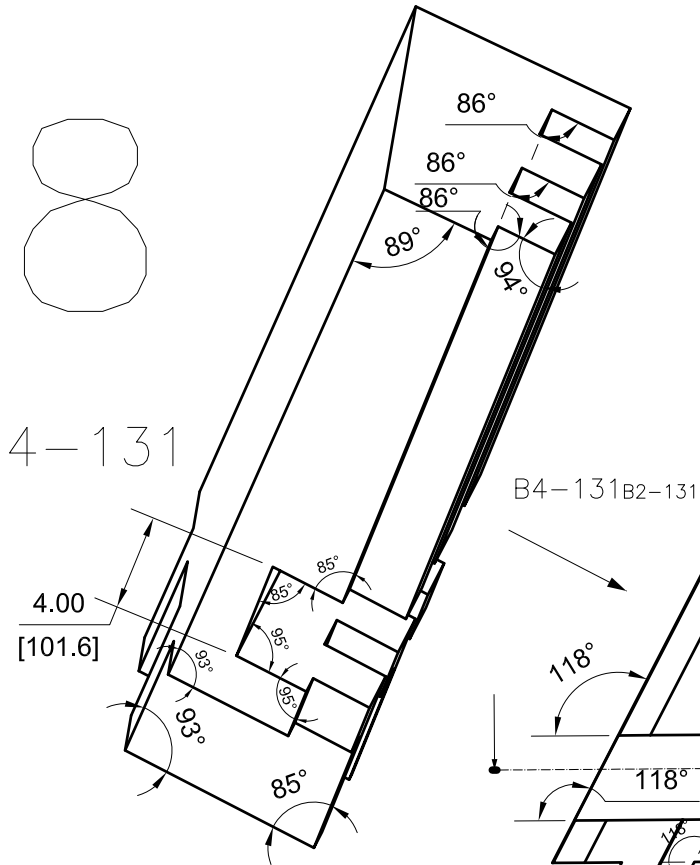

B4-131B2-131

VIEW D5-131

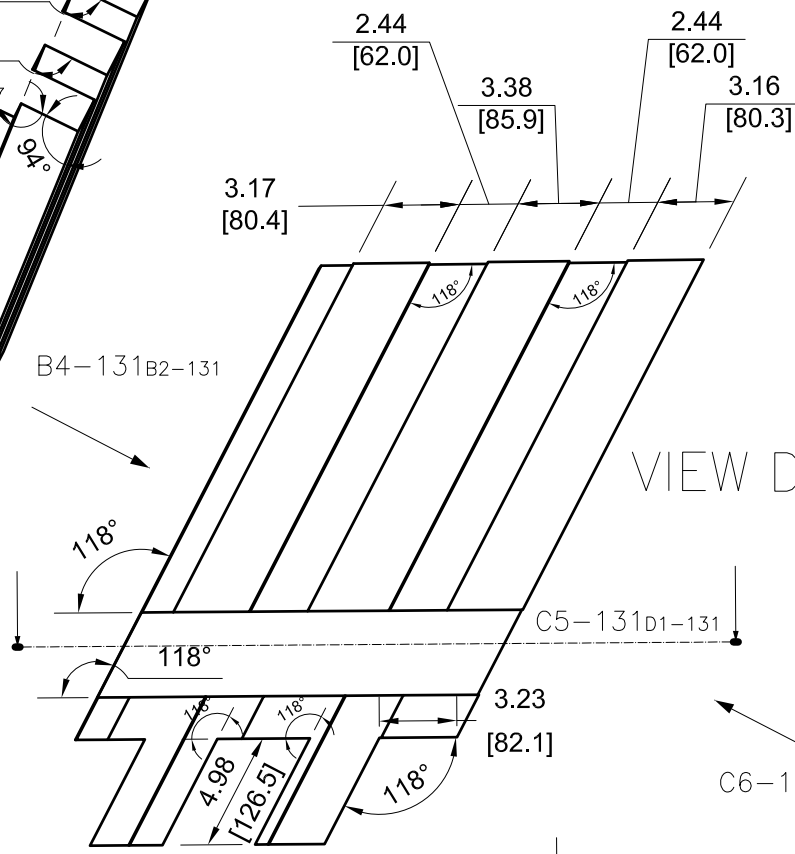

C5-131D1-131

D5-131B5-131

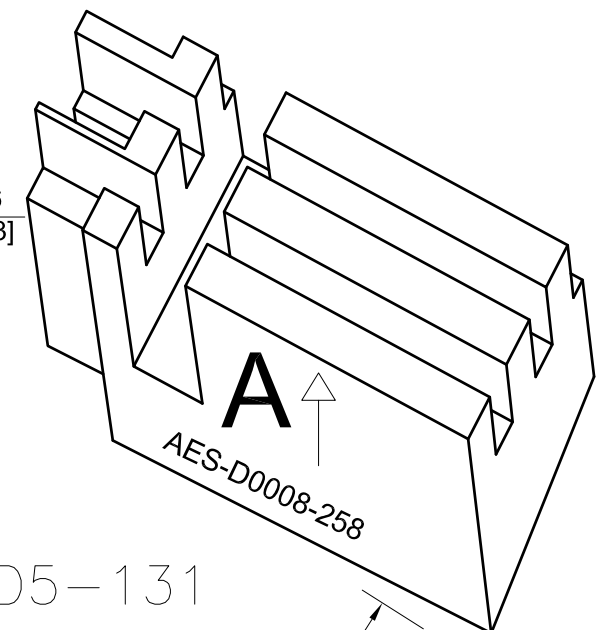

C6-131D7-131

VIEW C6-131

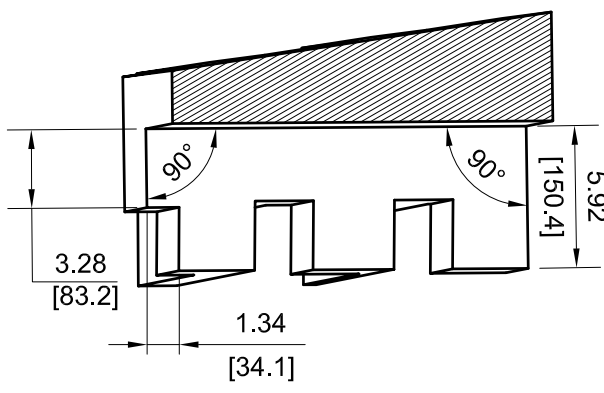
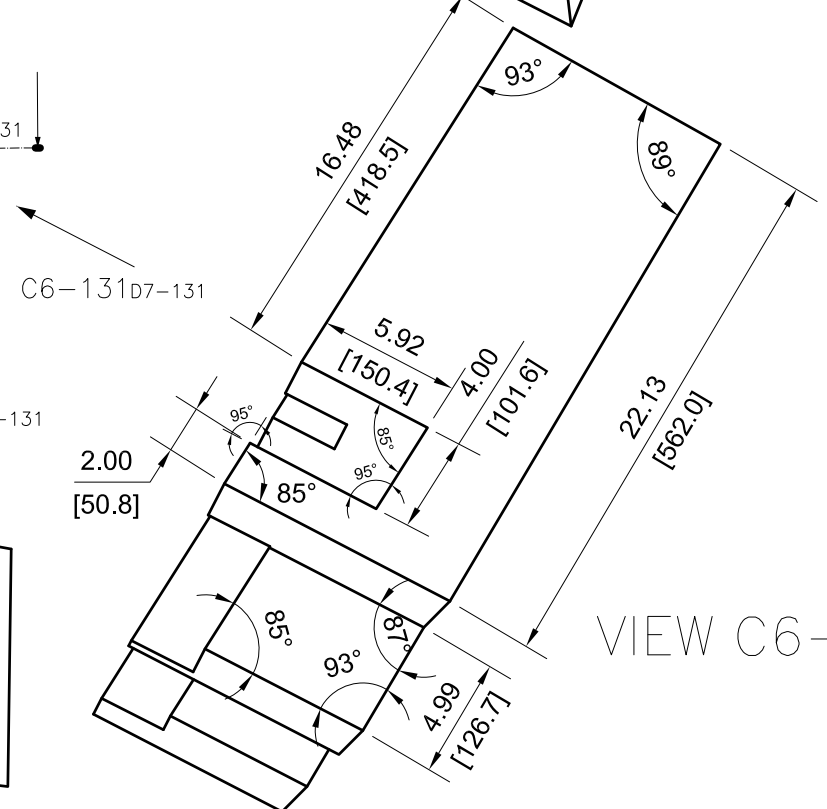

SECTION VIEW C5-131

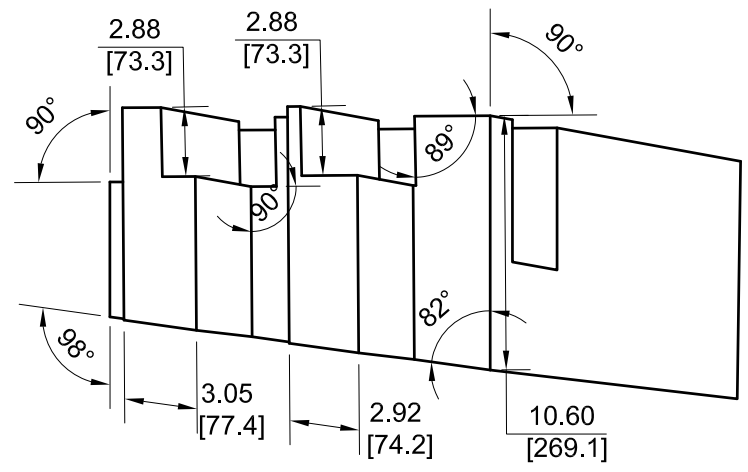
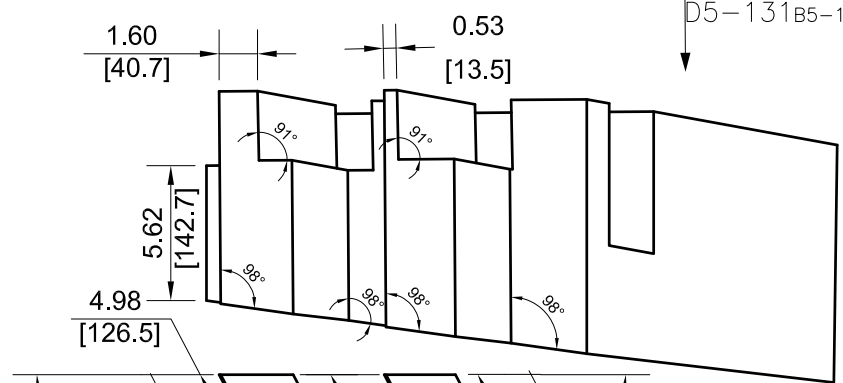

VIEW D4-131 REPEATED FOR CLARITY PURPOSES.

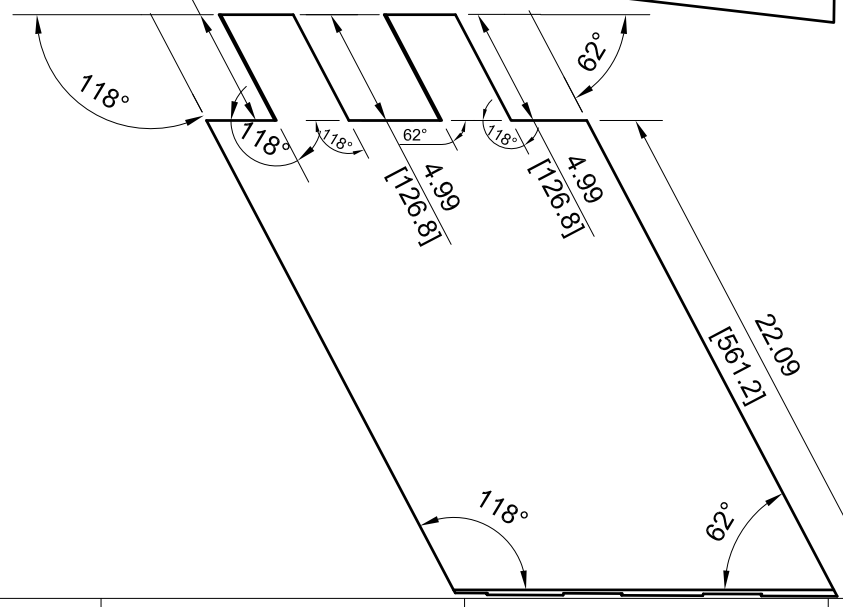

		DRAWING NUMBER			
		AES-D0008			
SIZE	SCALE	SHEET	OF	REVISION	
A3	NONE	131	190	B	

260

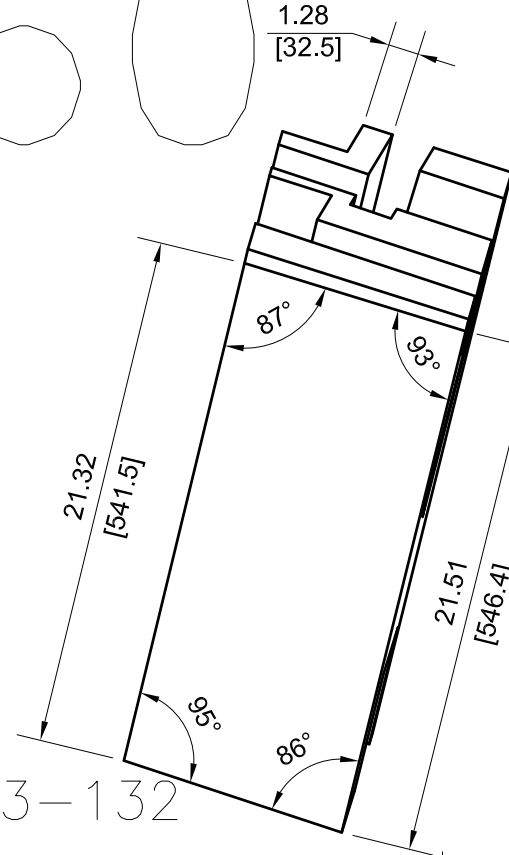

VIEW C3-132

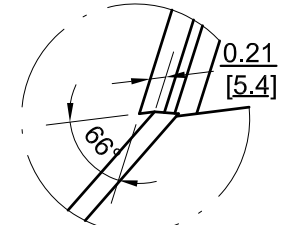

DETAIL B4-132

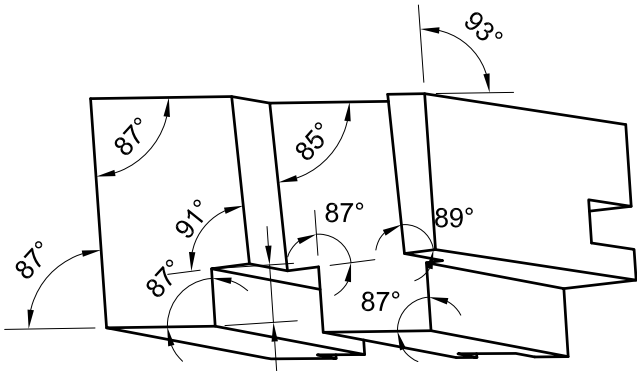

VIEW E4-132 REPEATED FOR CLARITY PURPOSES.

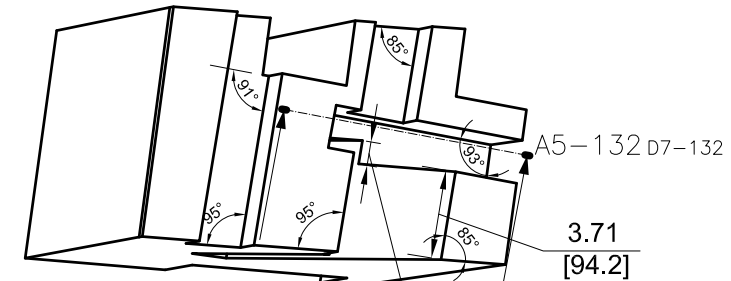

VIEW B4-132

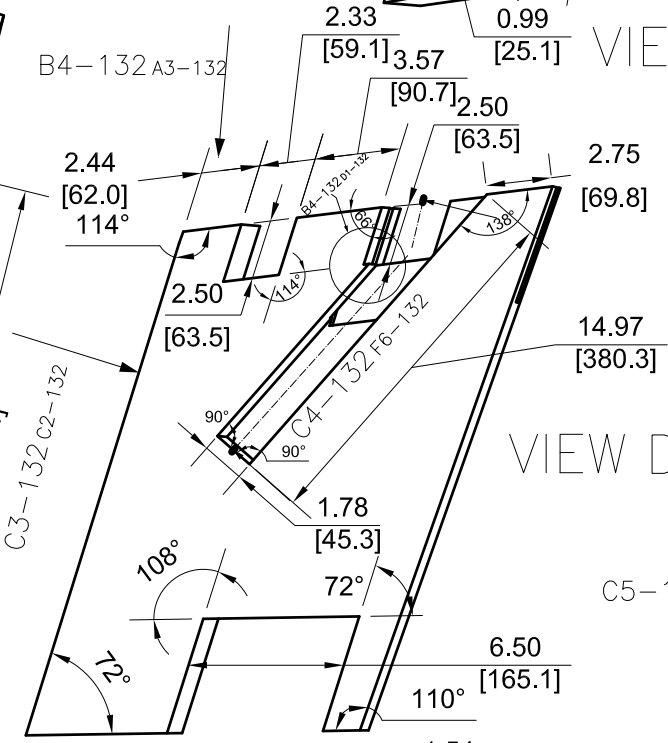

VIEW D3-132

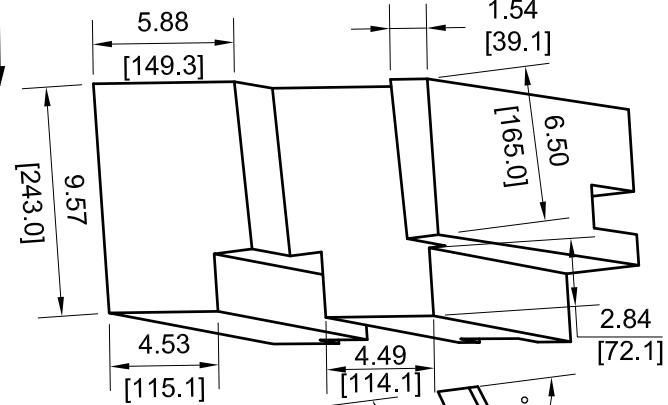

VIEW C5-132

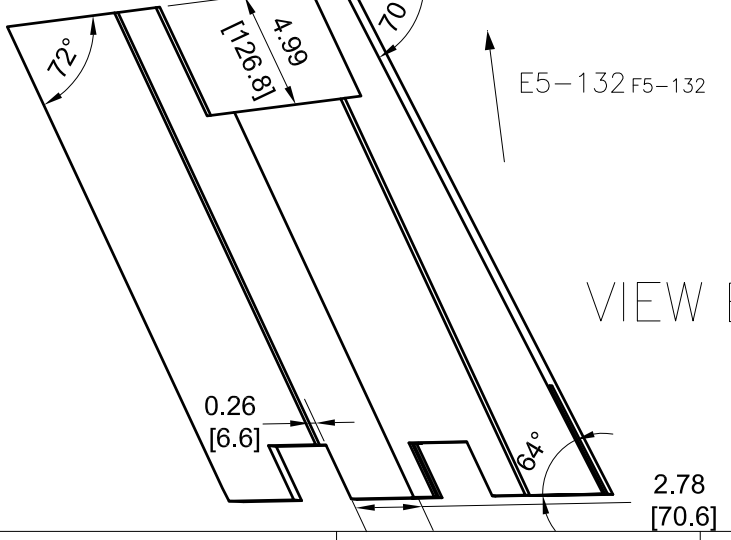

VIEW E5-132

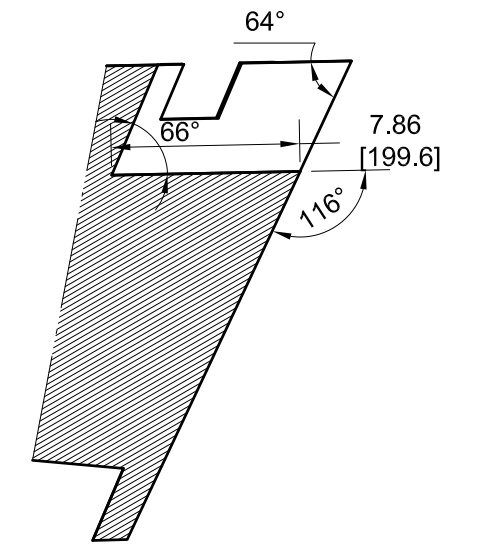
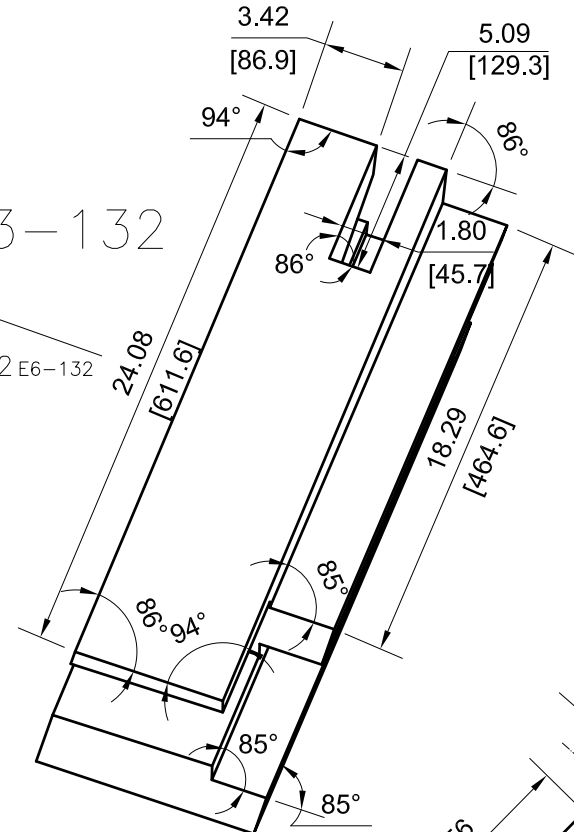
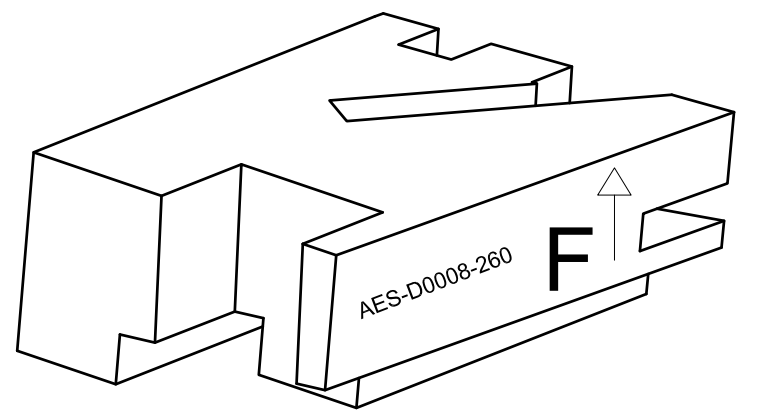

SECTION VIEW A5-132

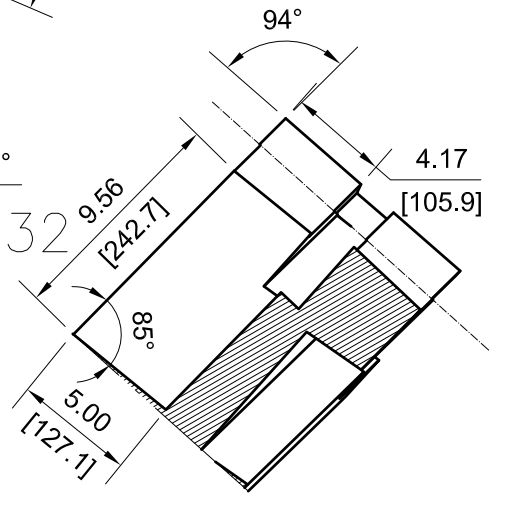

SECTION VIEW C4-132



DRAWING NUMBER				
AES-D0008				
SIZE	SCALE	SHEET	OF	REVISION
A3	NONE	132	190	B

262

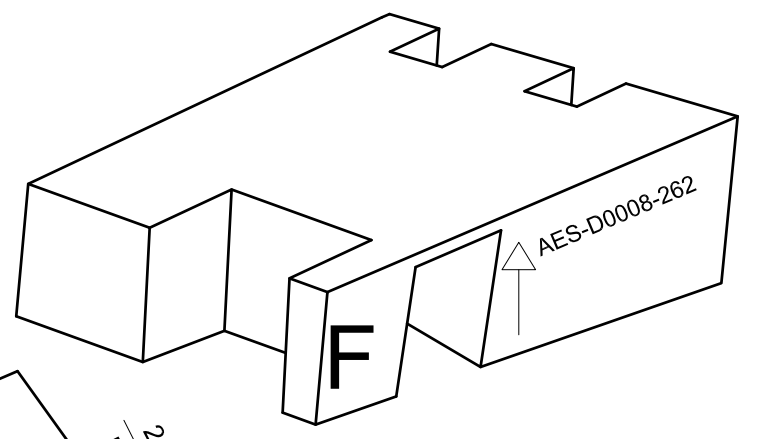
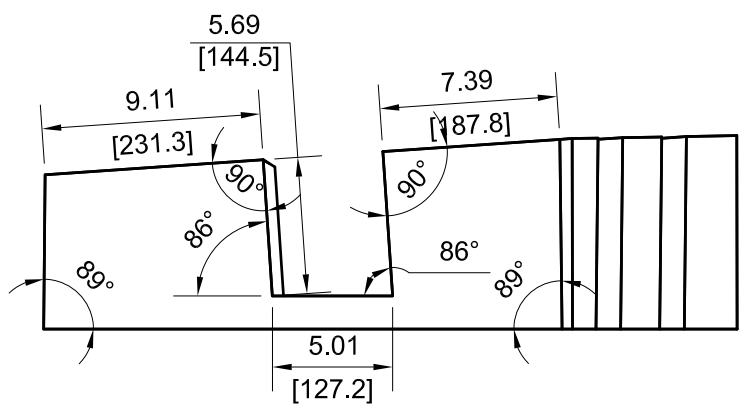

VIEW C6-133

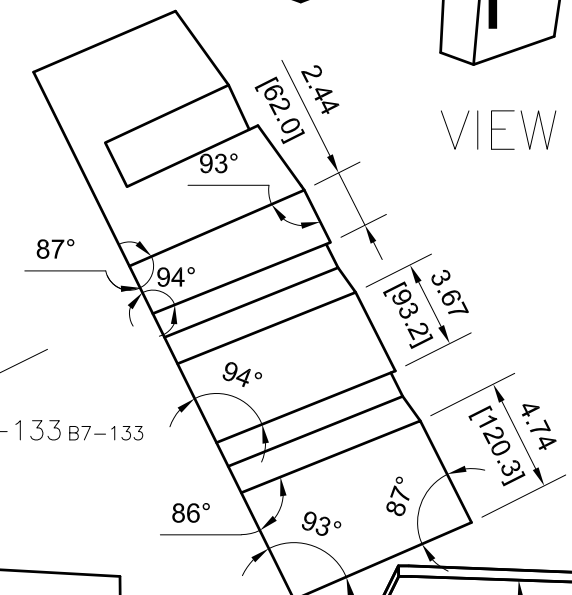

C6-133 B7-133

C2-133 E1-133

D2-133 F2-133

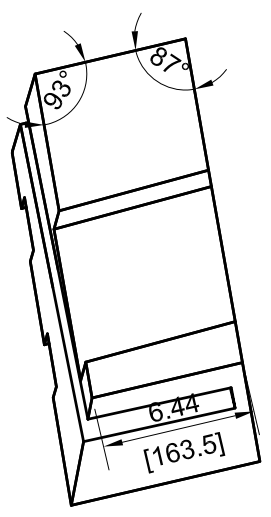
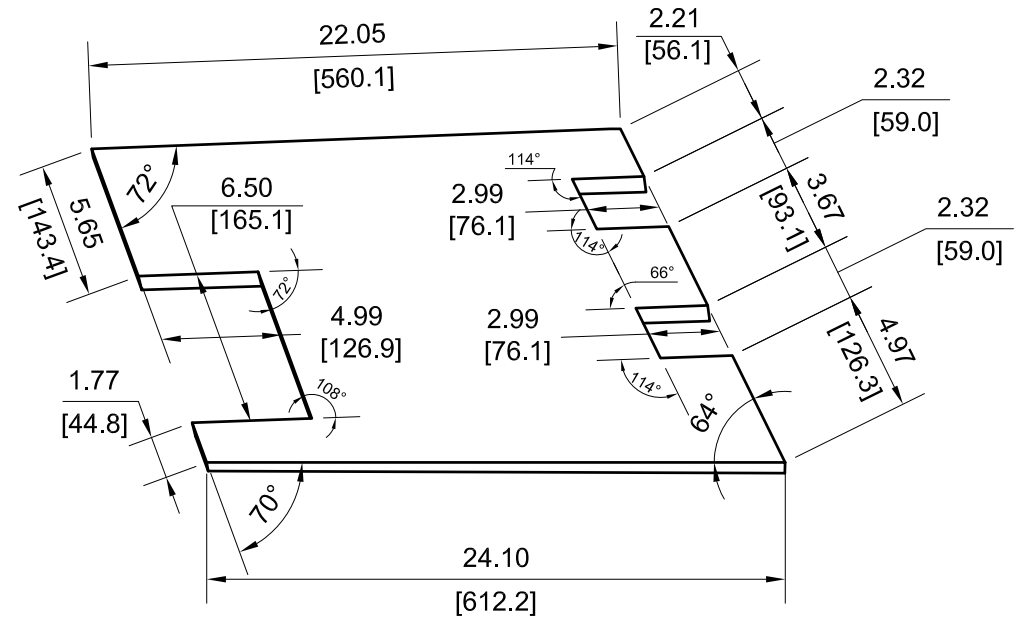

VIEW C2-133

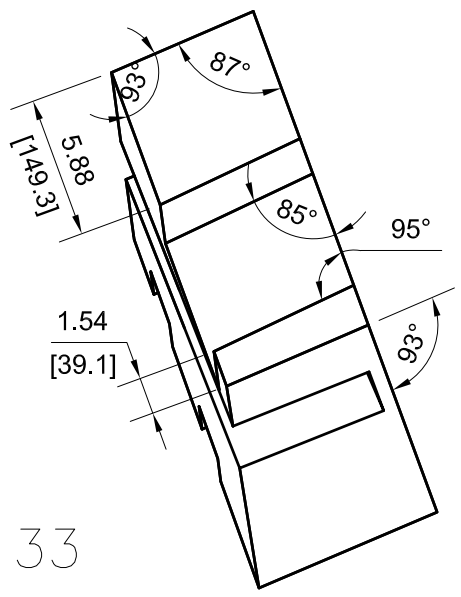

VIEW D2-133

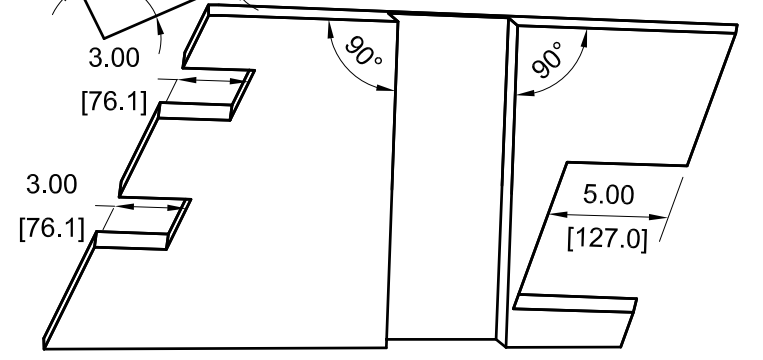
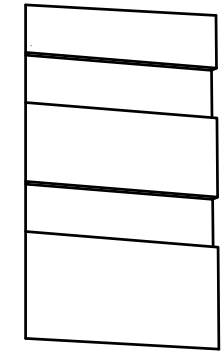
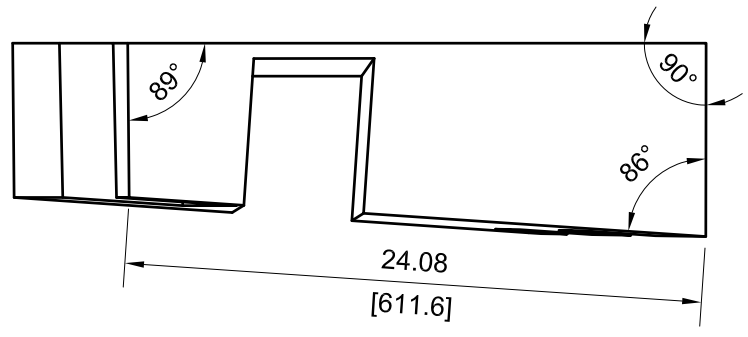

DRAWING NUMBER					AES-D0008				
SIZE	SCALE	SHEET	OF	REVISION					
A3	NONE	133	190	B					

264

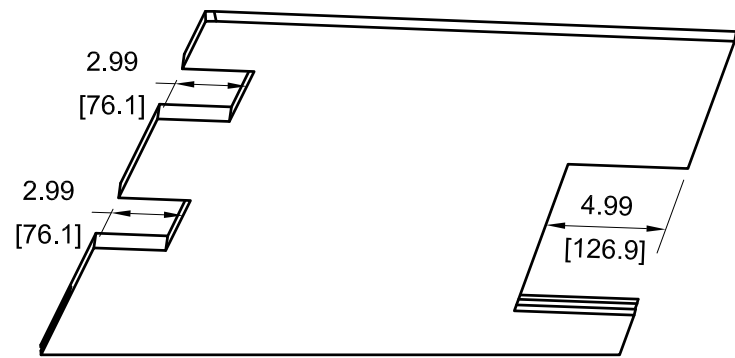

REAR VIEW RELATIVE TO VIEW D4-134

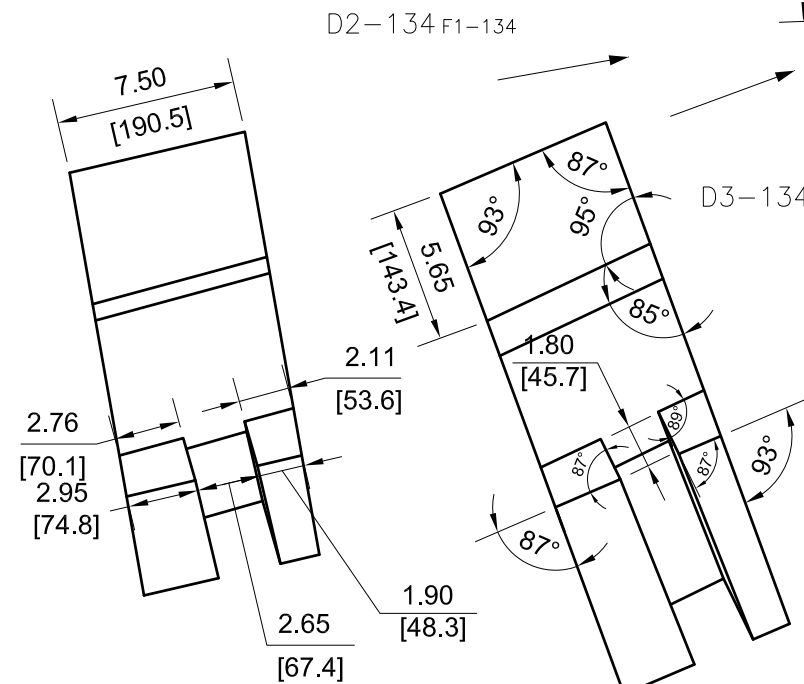
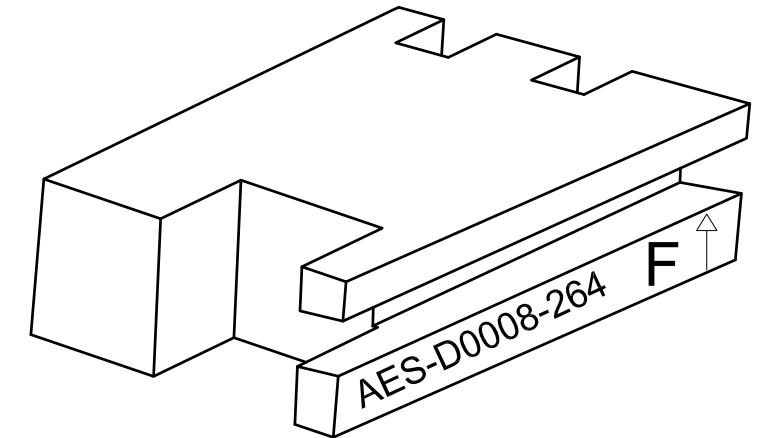
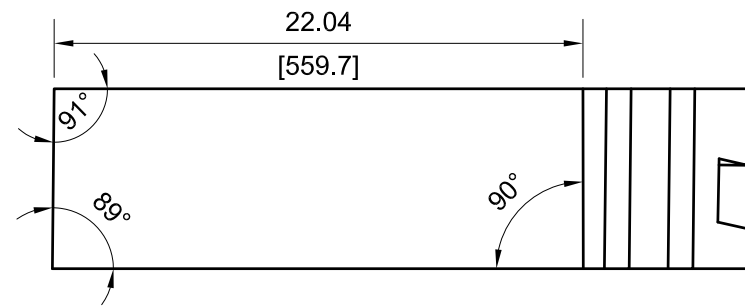

VIEW D2-134

D2-134 F1-134

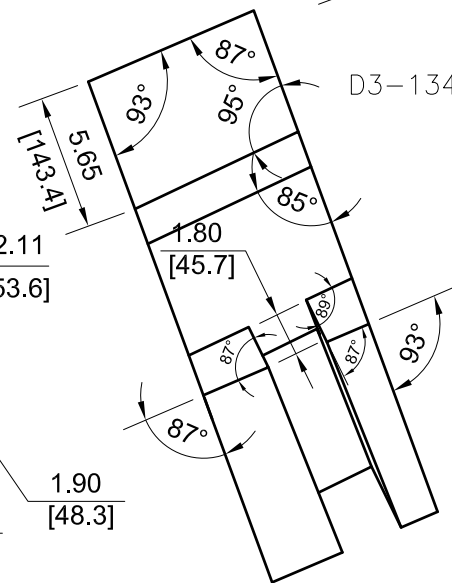

VIEW D3-134

D3-134 F2-134

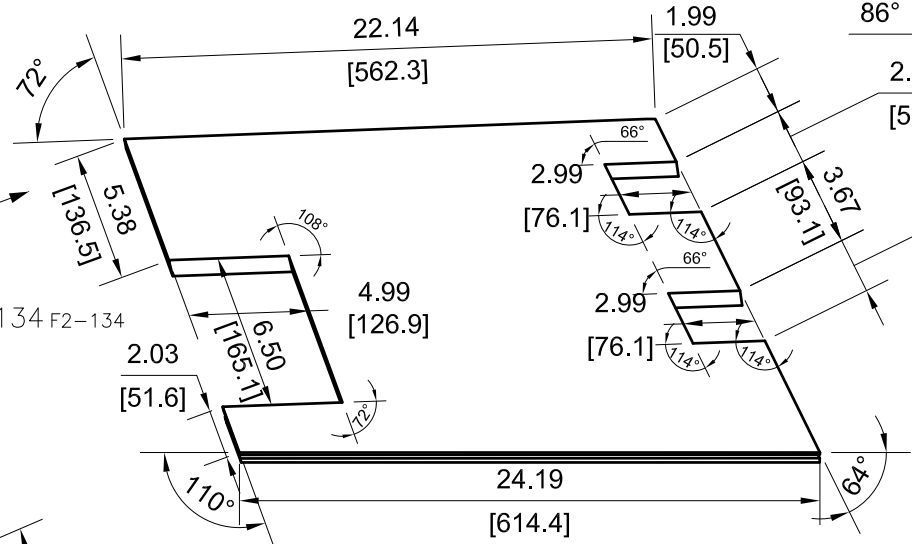

VIEW E6-134

E6-134 D6-134

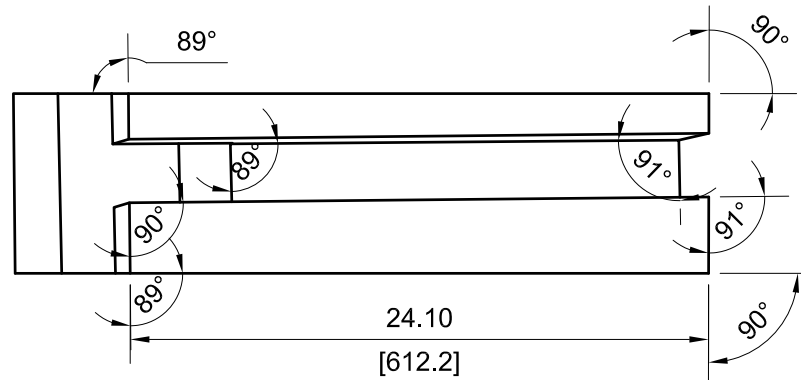

		DRAWING NUMBER			
		AES-D0008			
SIZE	SCALE	SHEET	OF	REVISION	
A3	NONE	134	190	B	

— 266

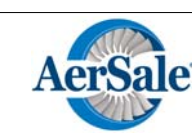
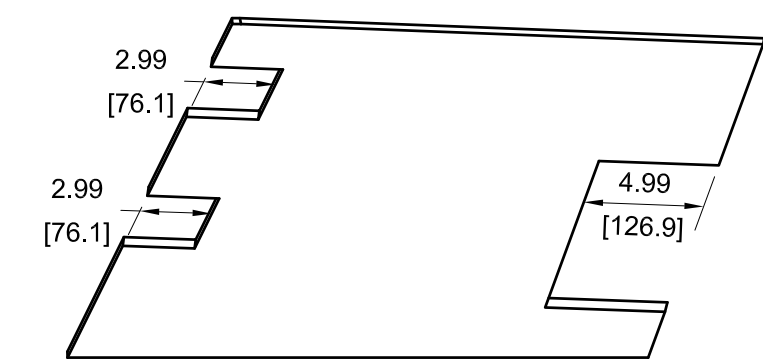
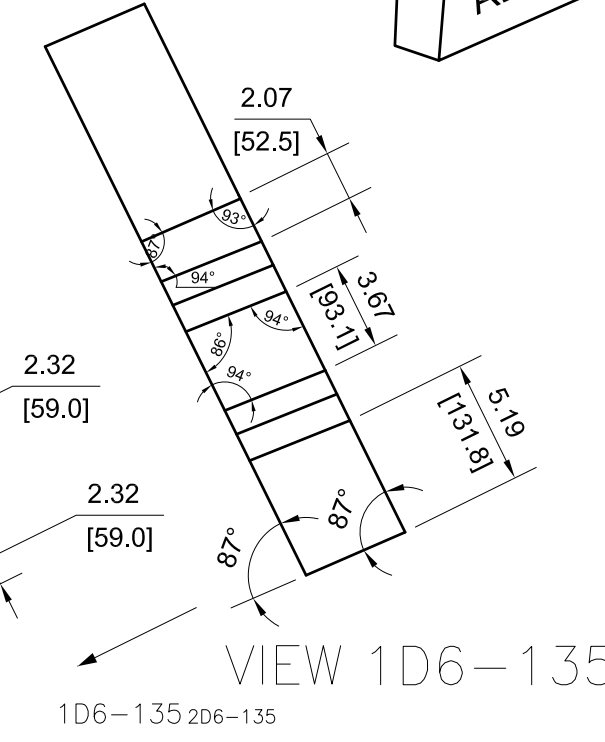
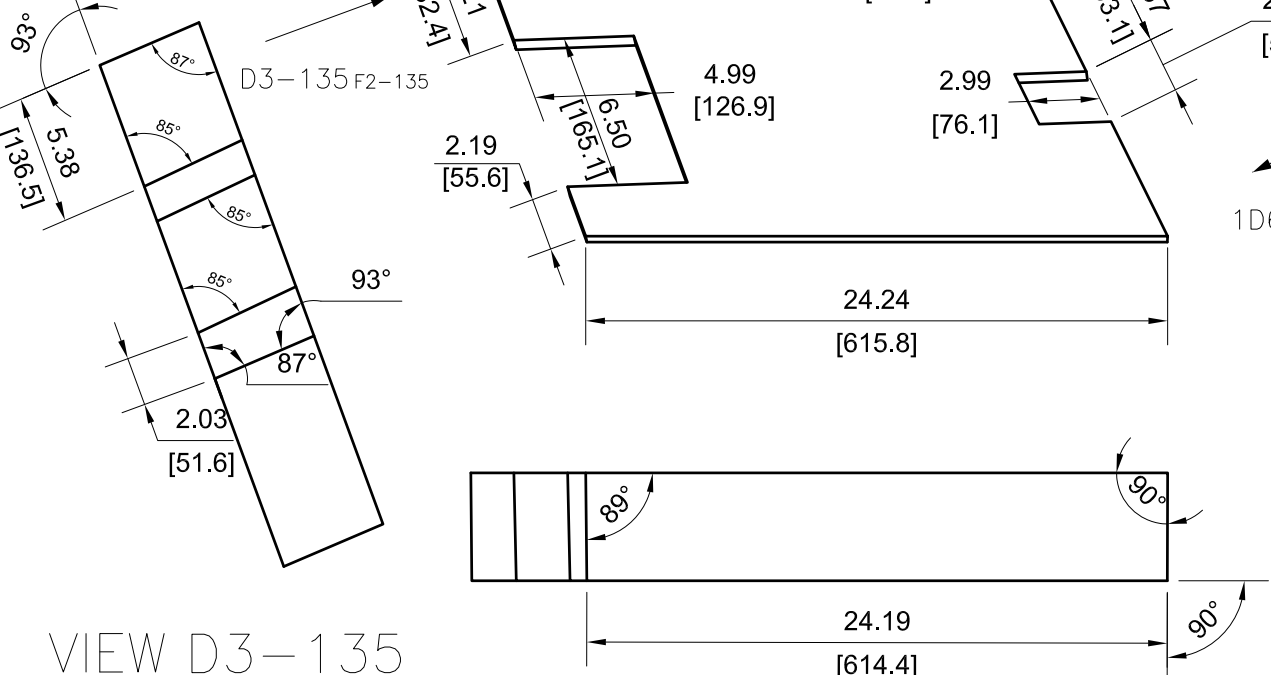
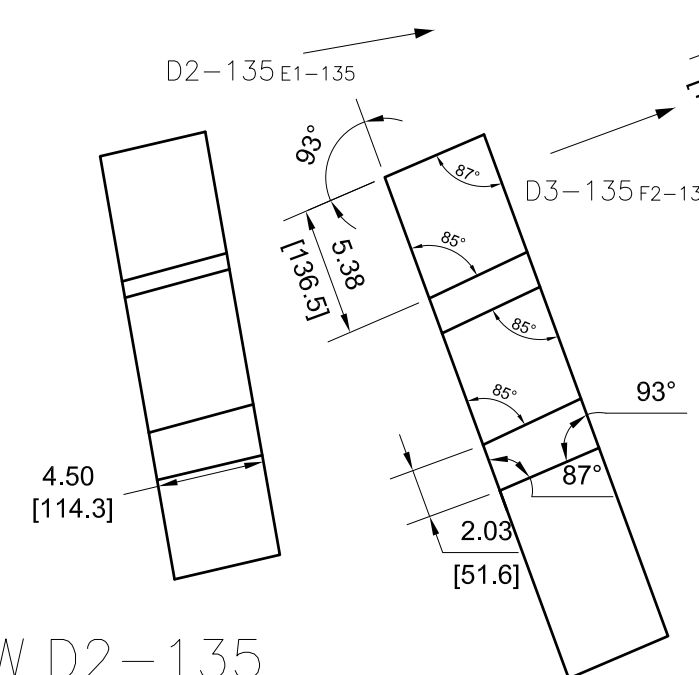
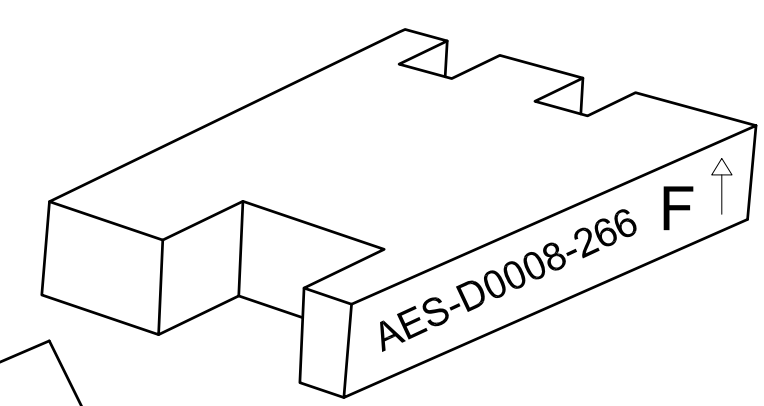
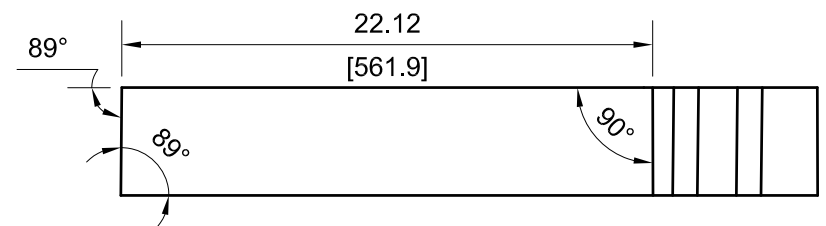

DRAWING NUMBER				
AES-D0008				
SIZE	SCALE	SHEET	OF	REVISION
A3	NONE	135	190	B

268

VIEW D3-136

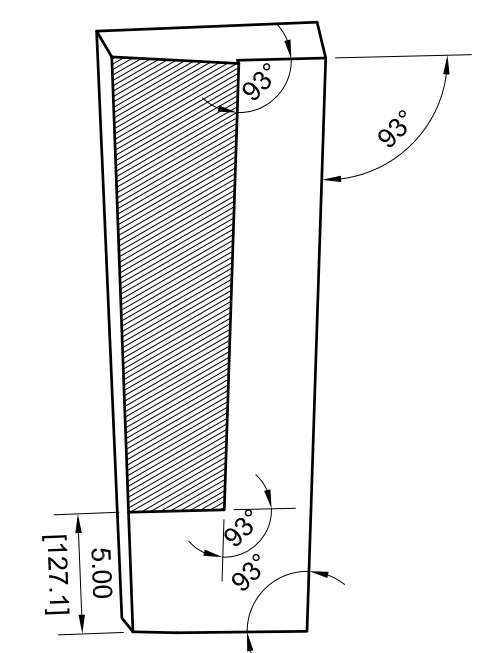
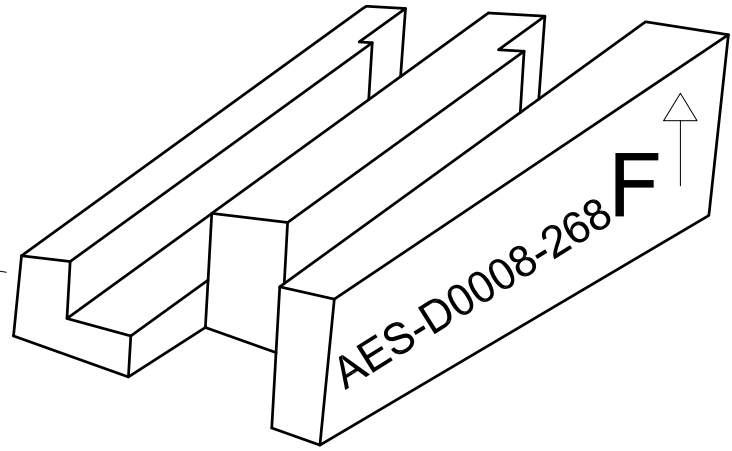

SECTION VIEW C4-136

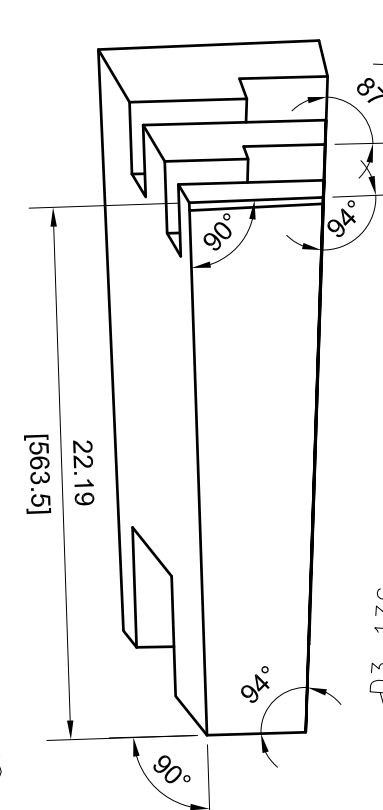

VIEW B2-136

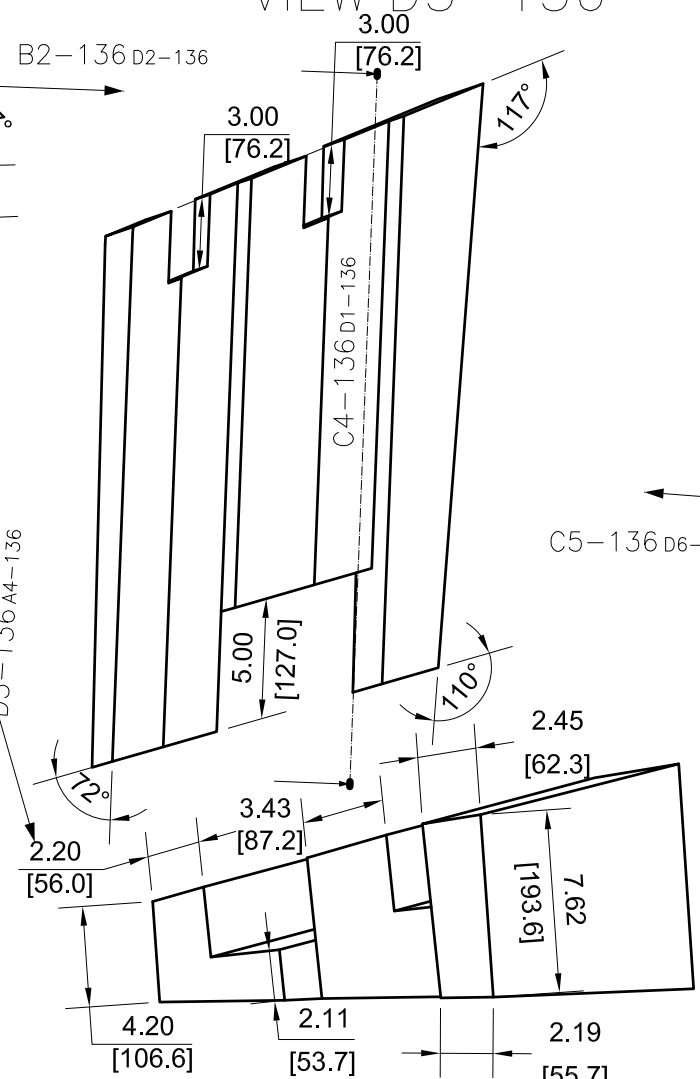

VIEW C5-136

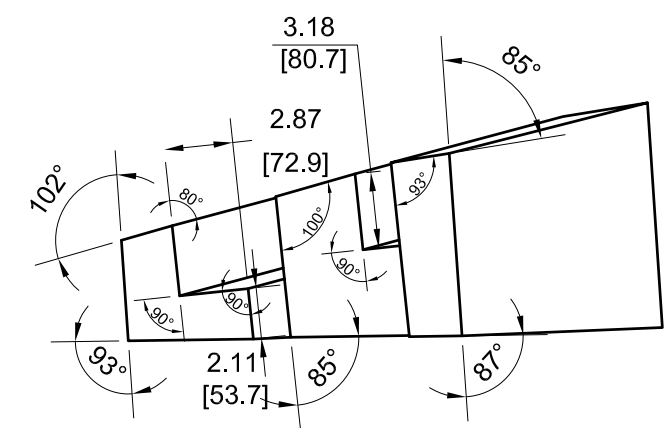
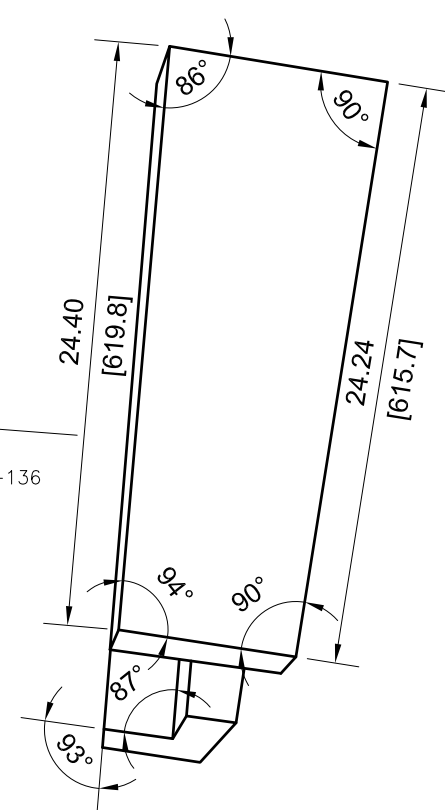

VIEW D4-136 REPEATED FOR CLARITY PURPOSES.

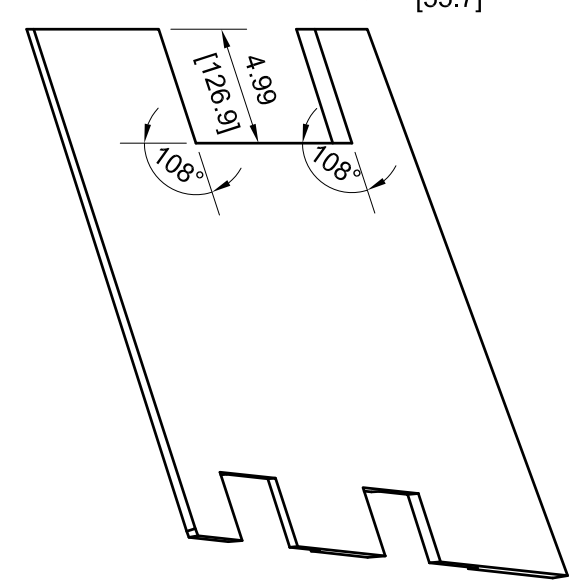

		DRAWING NUMBER			
		AES-D0008			
SIZE	SCALE	SHEET	OF	REVISION	
A3	NONE	136	190	B	

270

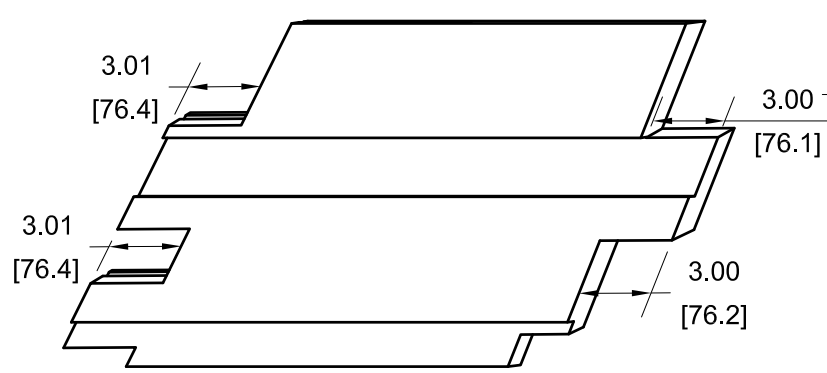

REAR VIEW RELATIVE TO VIEW C4-137

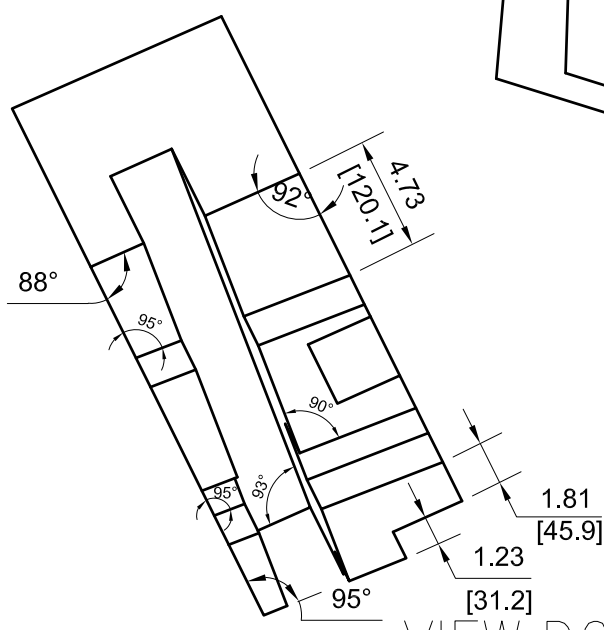
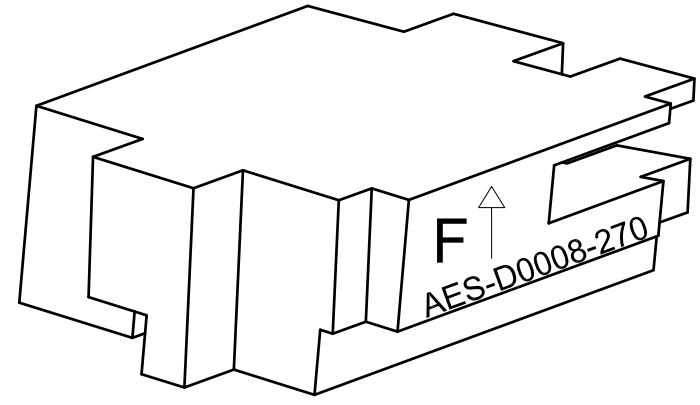
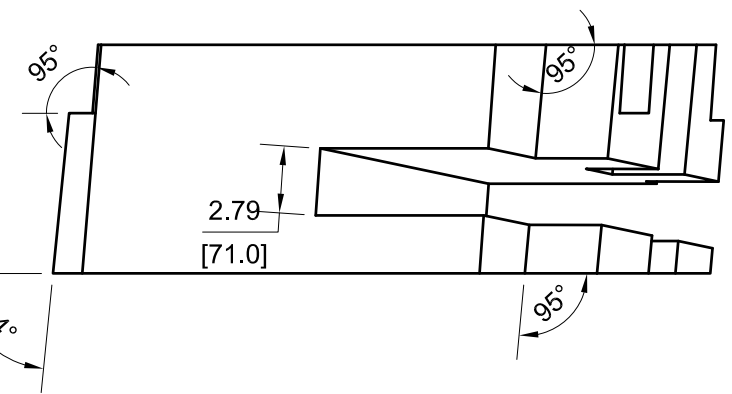

VIEW D6-137

C2-137 E1-137

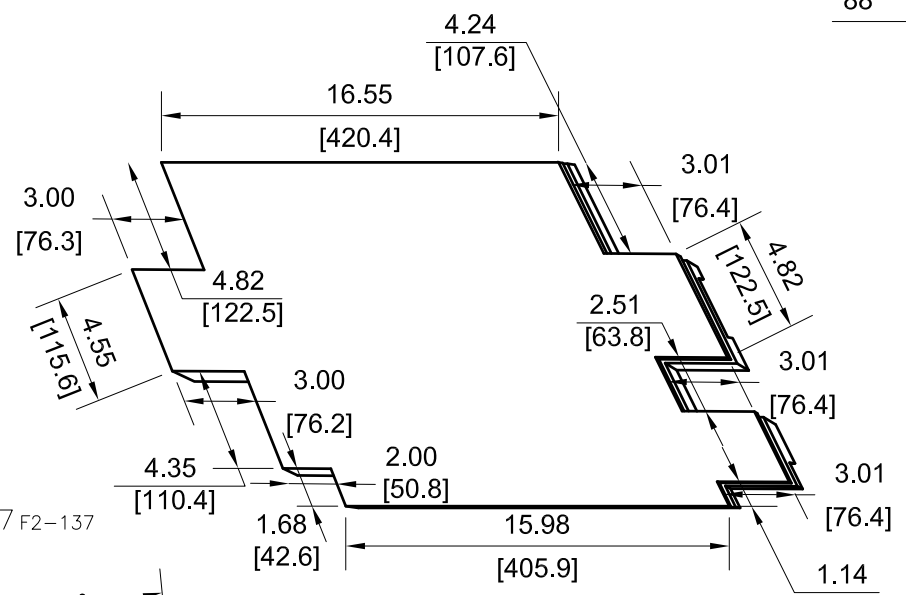

D3-137 F2-137

D6-137 C6-137

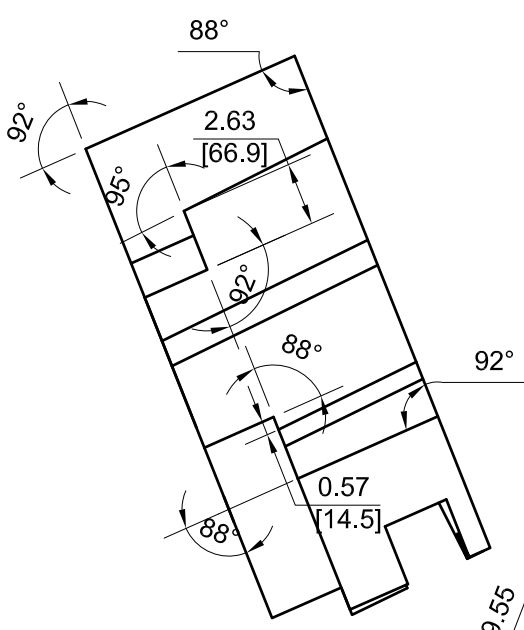

VIEW C2-137

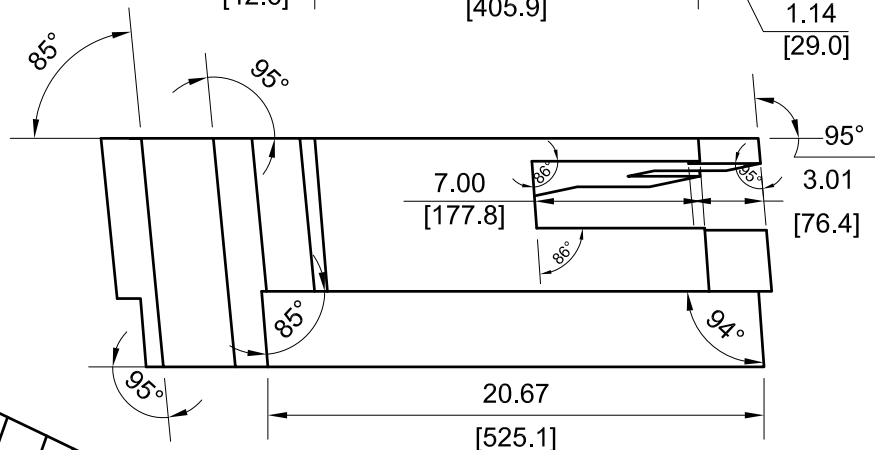

VIEW D4-137 REPEATED FOR CLARITY PURPOSES.

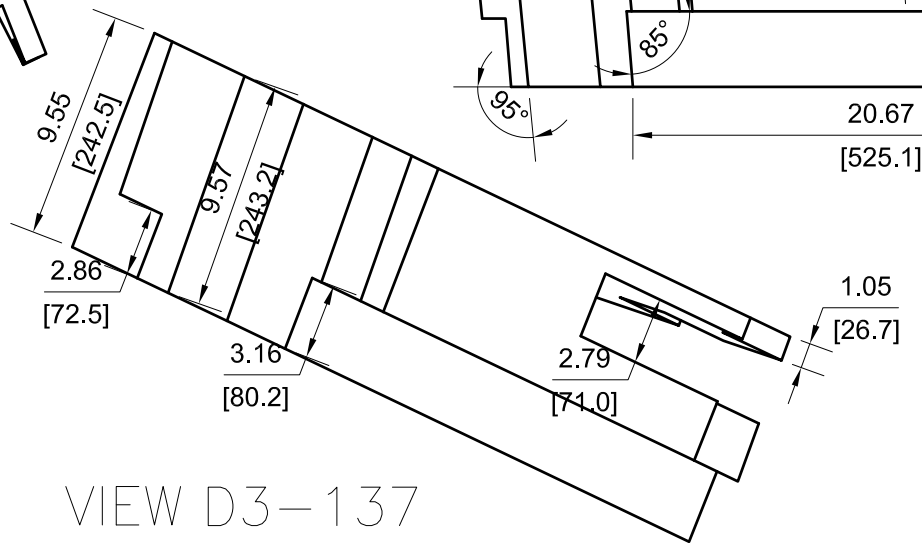

VIEW D3-137

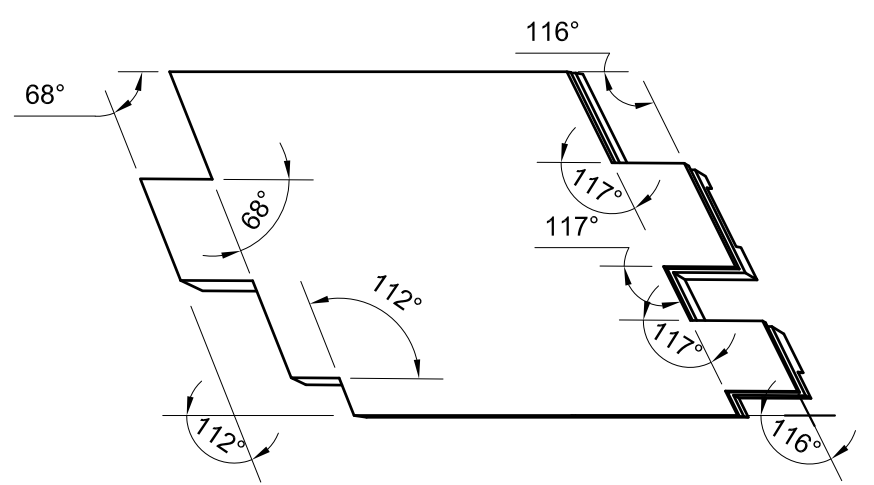

	DRAWING NUMBER				
	AES-D0008				
SIZE	SCALE	SHEET	OF	REVISION	
A3	NONE	137	190	B	

272

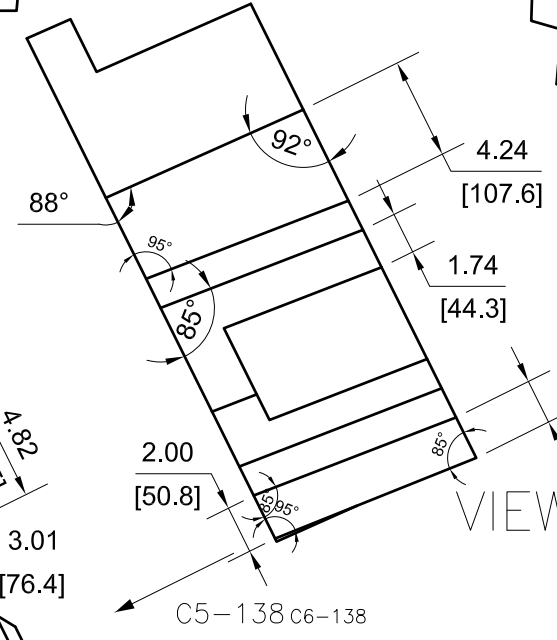
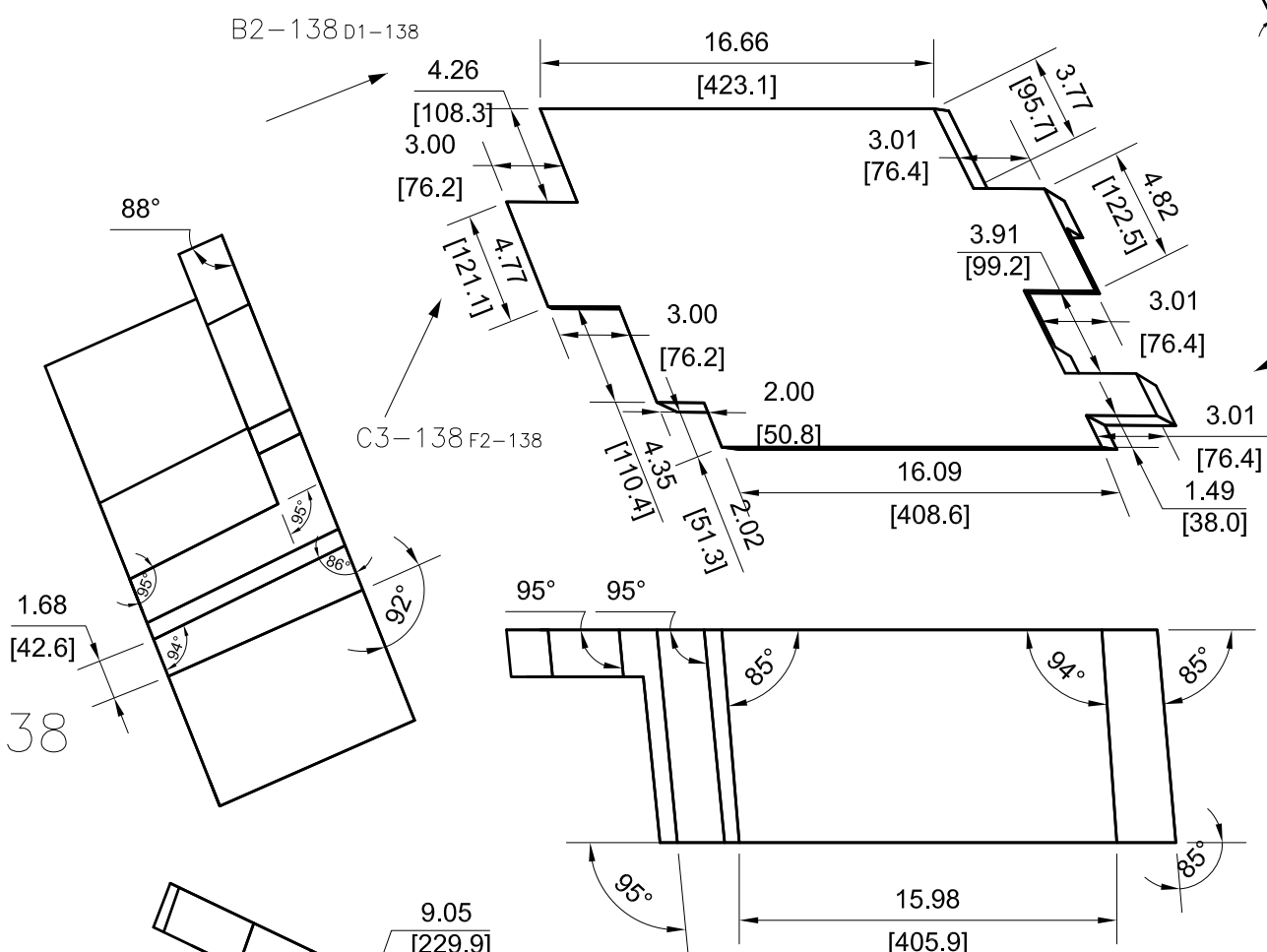
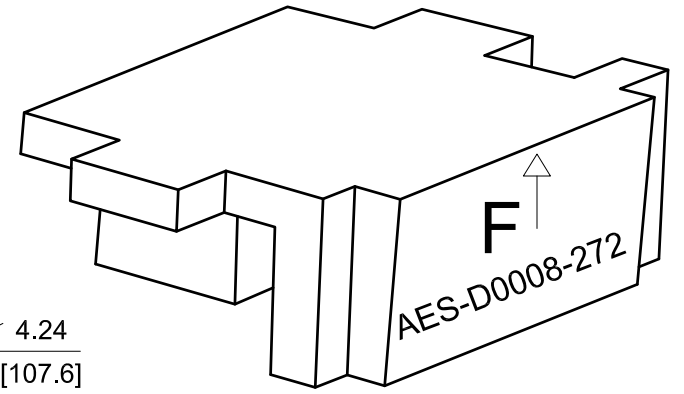
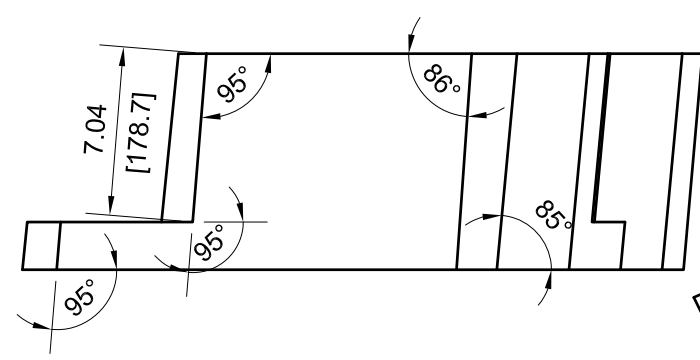

VIEW C5-138

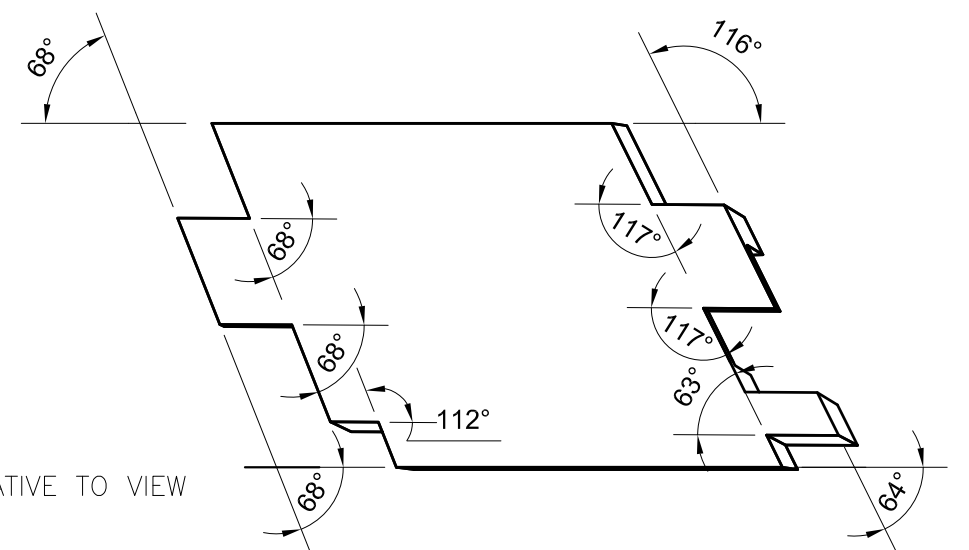

VIEW C4-138 REPEATED FOR CLARITY PURPOSES.

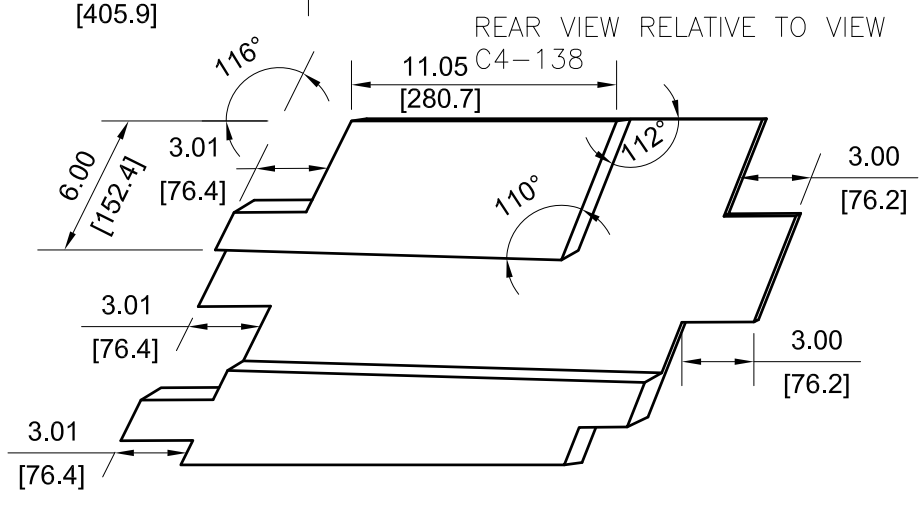

REAR VIEW RELATIVE TO VIEW C4-138

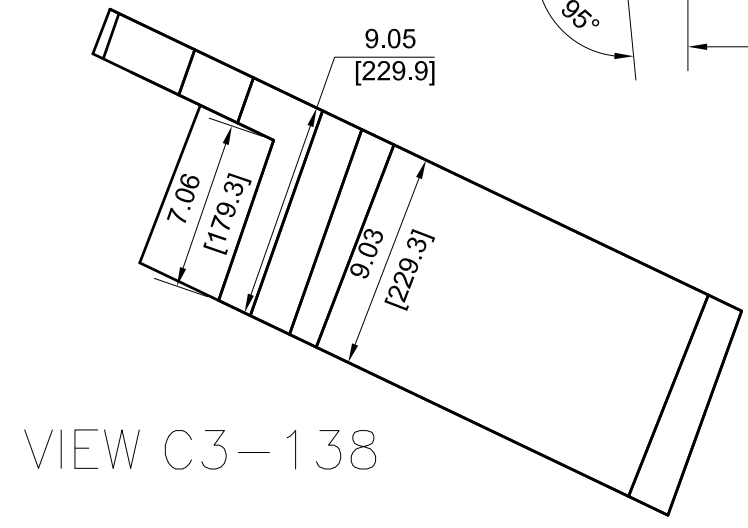

VIEW C3-138



DRAWING NUMBER					AES-D0008	
SIZE	SCALE	SHEET	OF	REVISION		
A3	NONE	138	190	B		

276

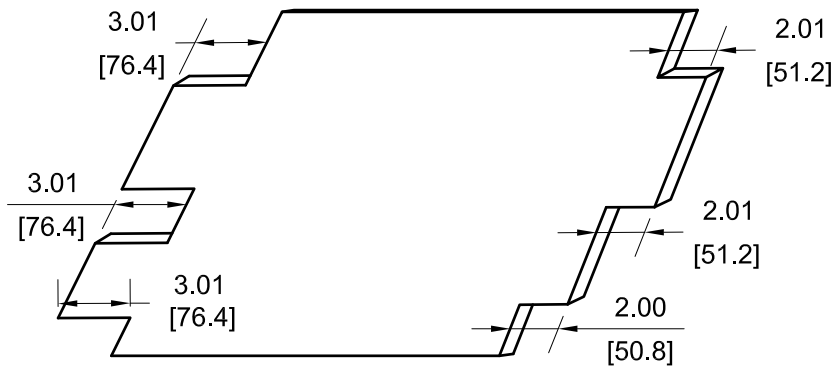

REAR VIEW RELATIVE TO VIEW C4-140

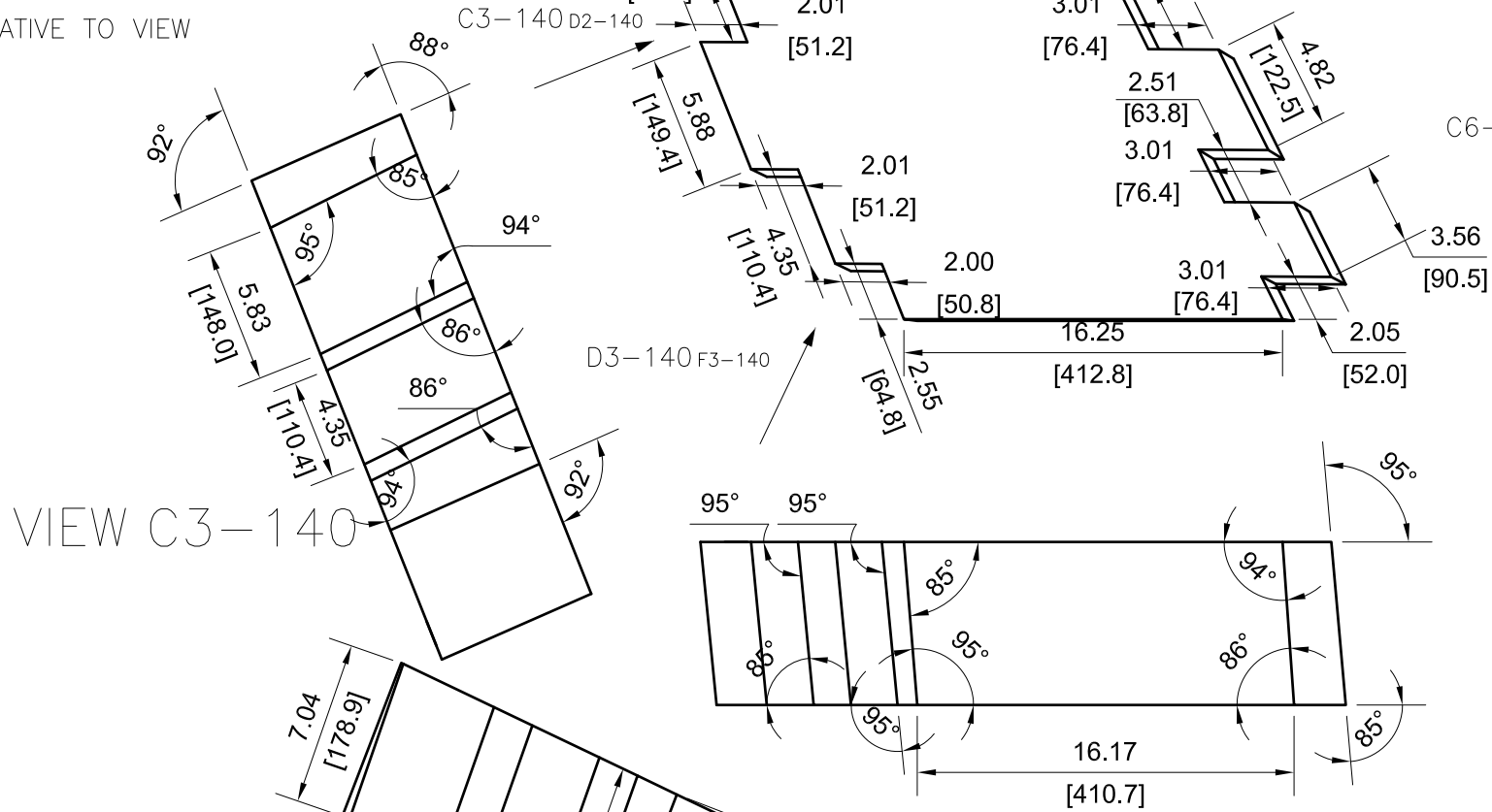
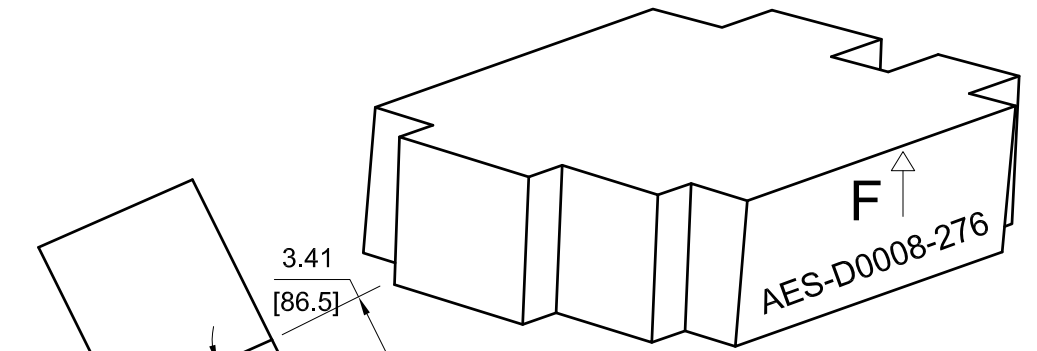
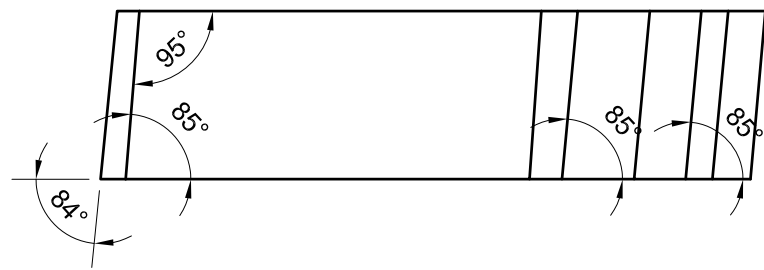

VIEW C3-140

VIEW D3-140

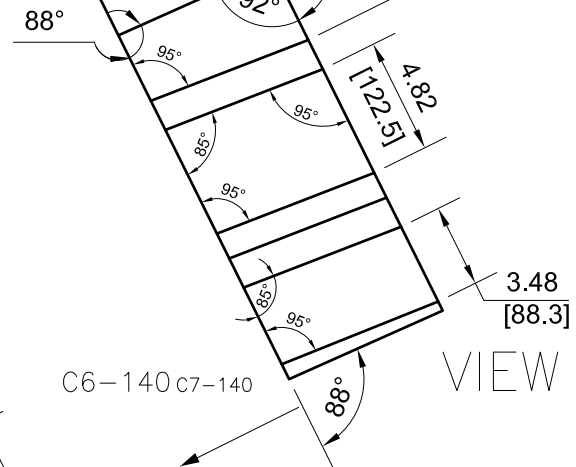

VIEW C6-140

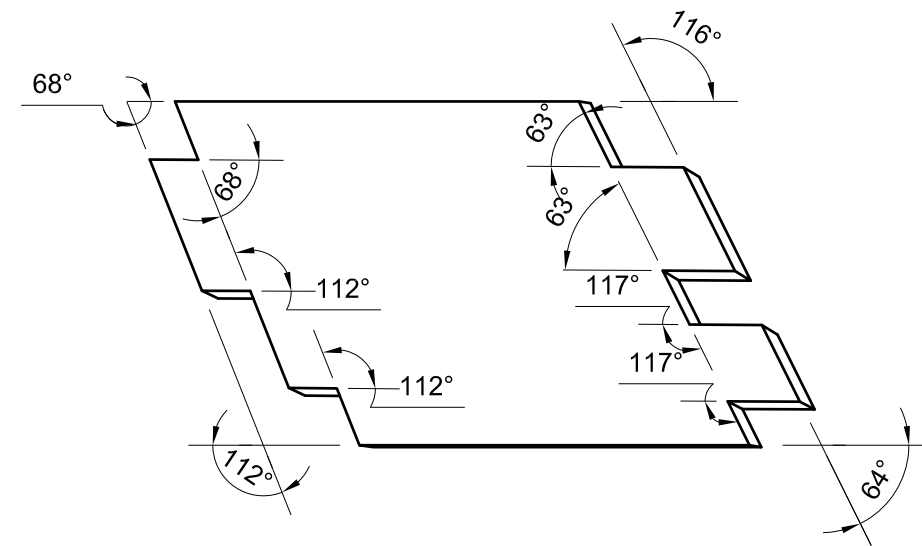

VIEW C4-140 REPEATED FOR CLARITY PURPOSES.



DRAWING NUMBER				
AES-D0008				
SIZE	SCALE	SHEET	OF	REVISION
A3	NONE	140	190	B

278

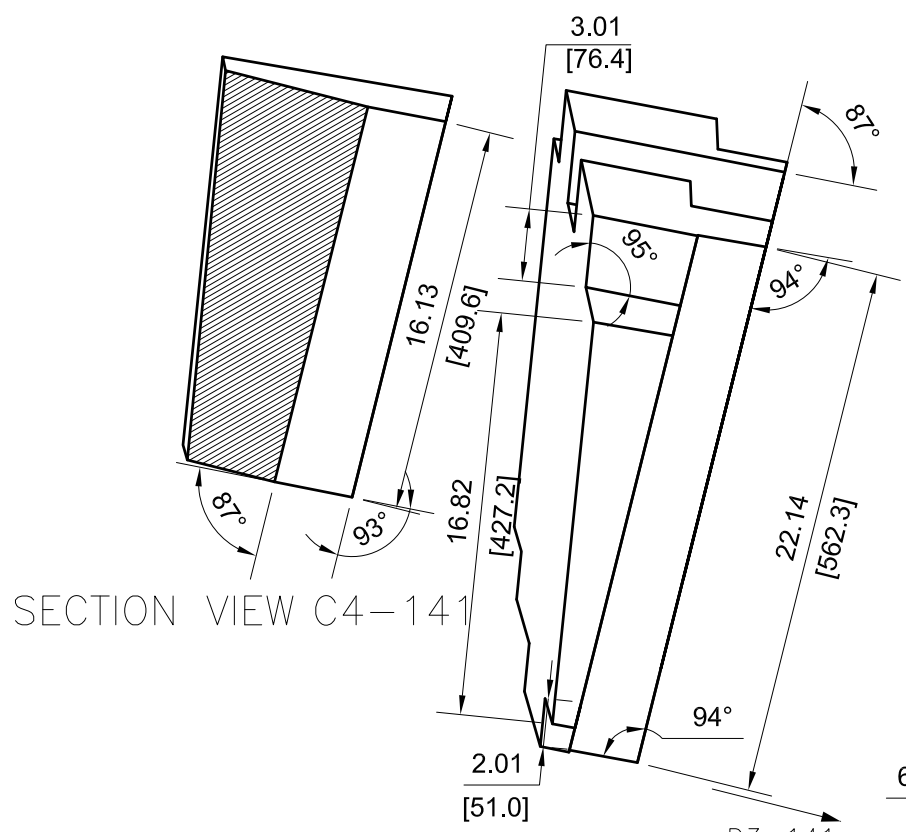

SECTION VIEW C4-141

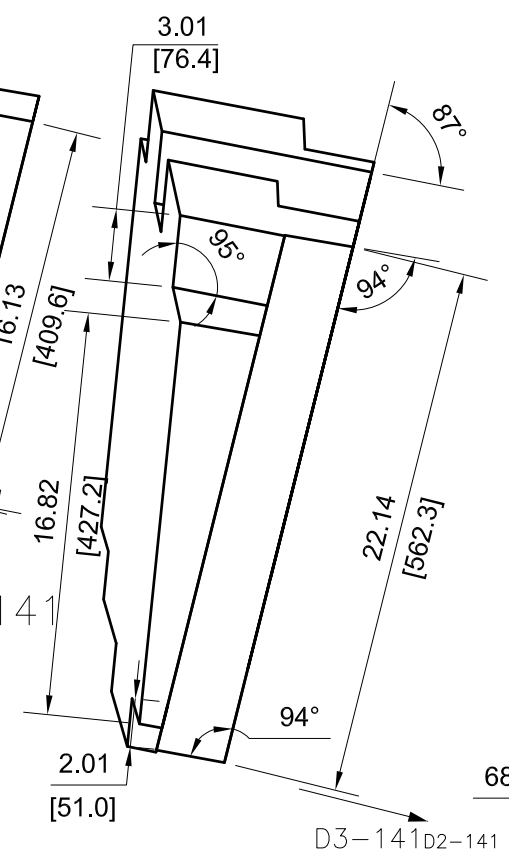

VIEW D3-141

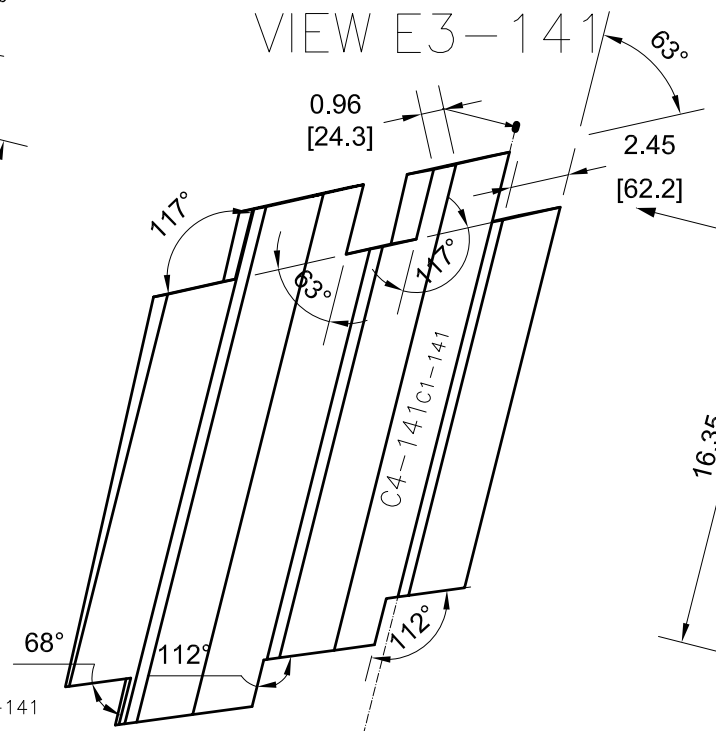

VIEW E3-141

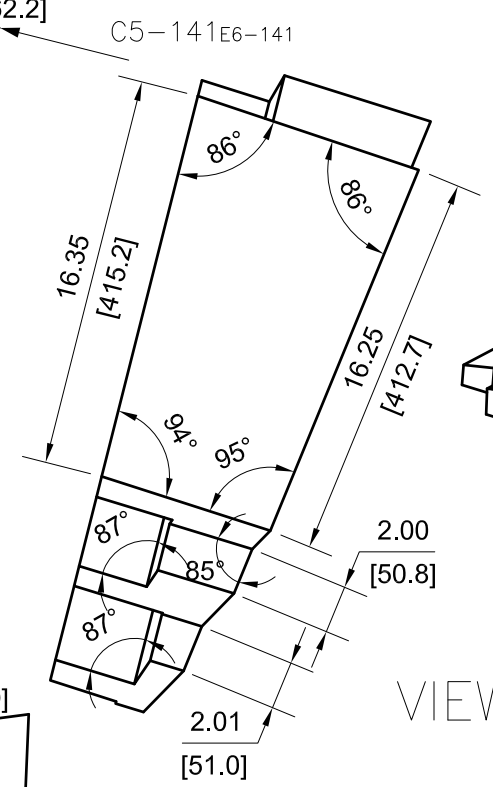

VIEW C5-141

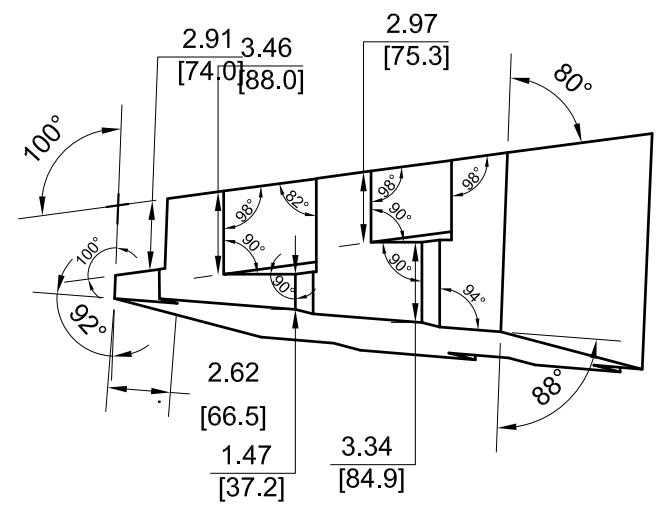
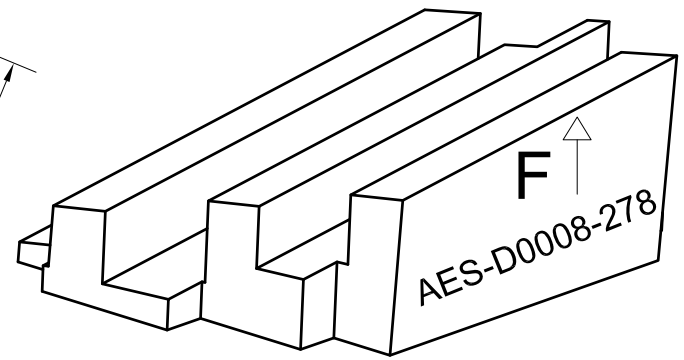

VIEW E4-141 REPEATED FOR CLARITY PURPOSES.

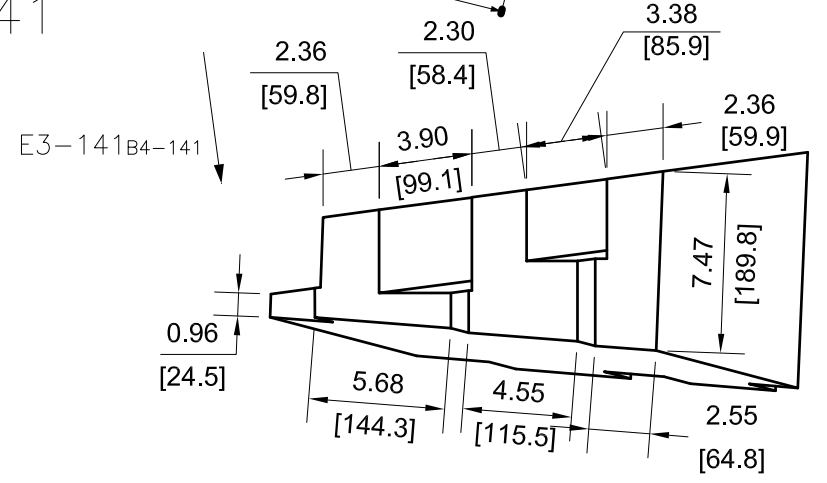

VIEW E3-141B4-141

		DRAWING NUMBER			
		AES-D0008			
SIZE	SCALE	SHEET	OF	REVISION	
A3	NONE	141	190	B	

— 280

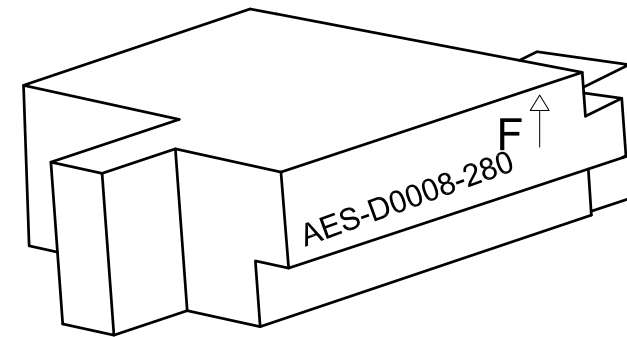
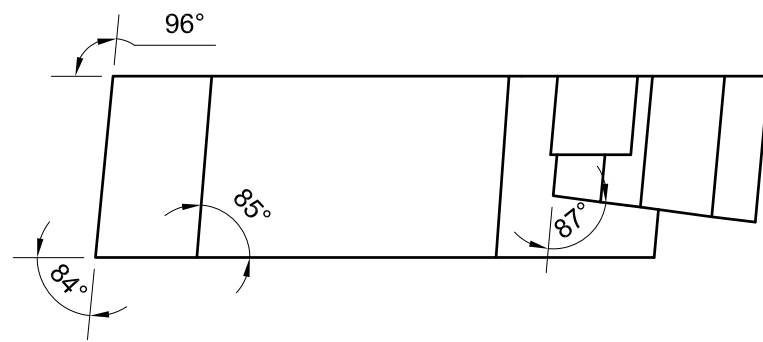

VIEW D3-142

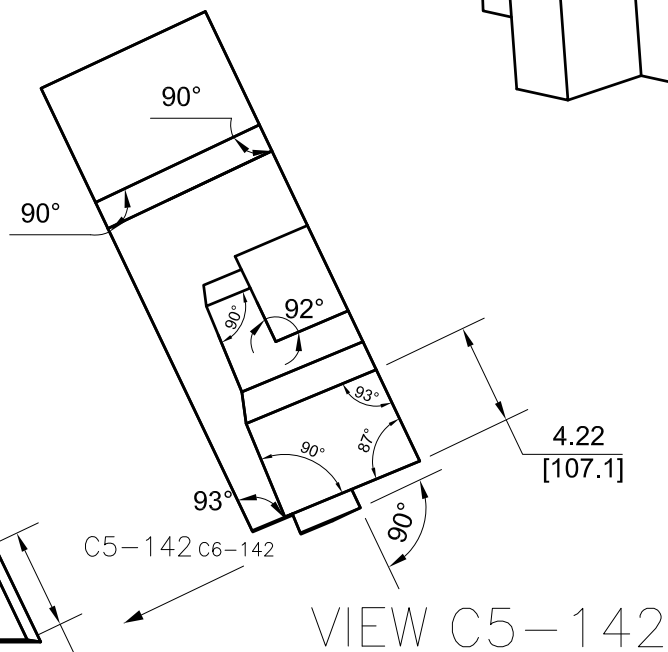
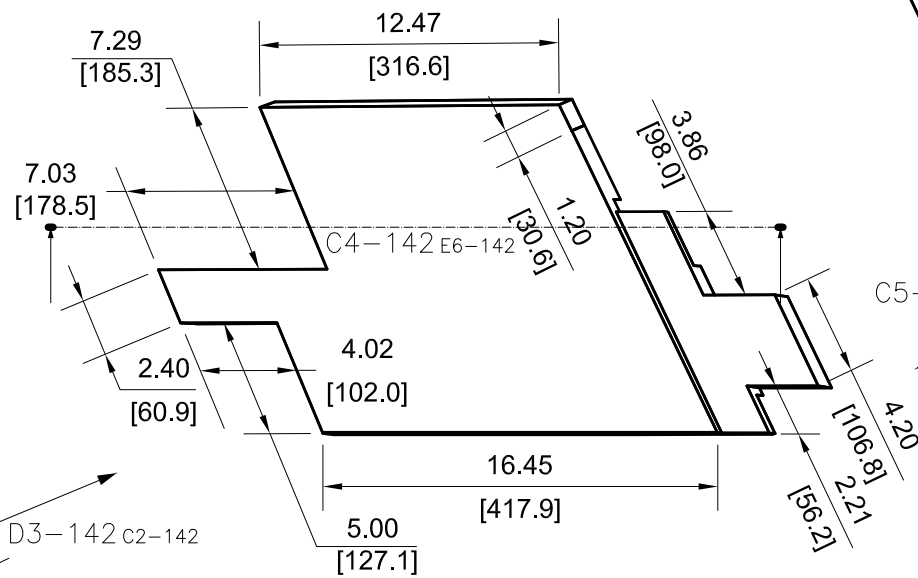
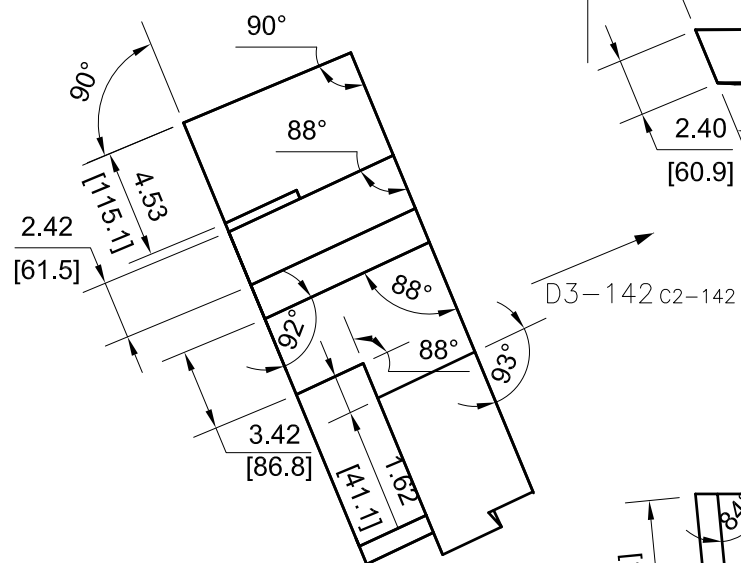

VIEW C5-142

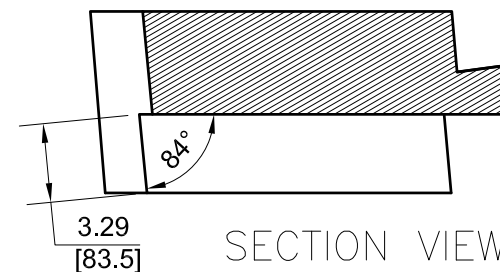
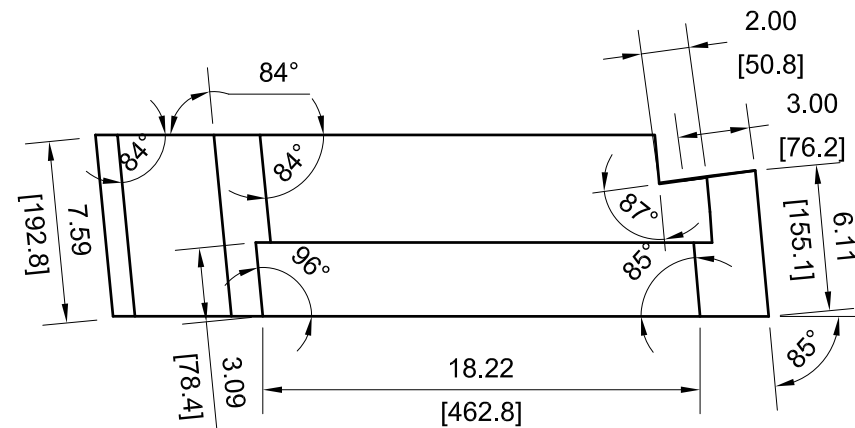

SECTION VIEW C4-142

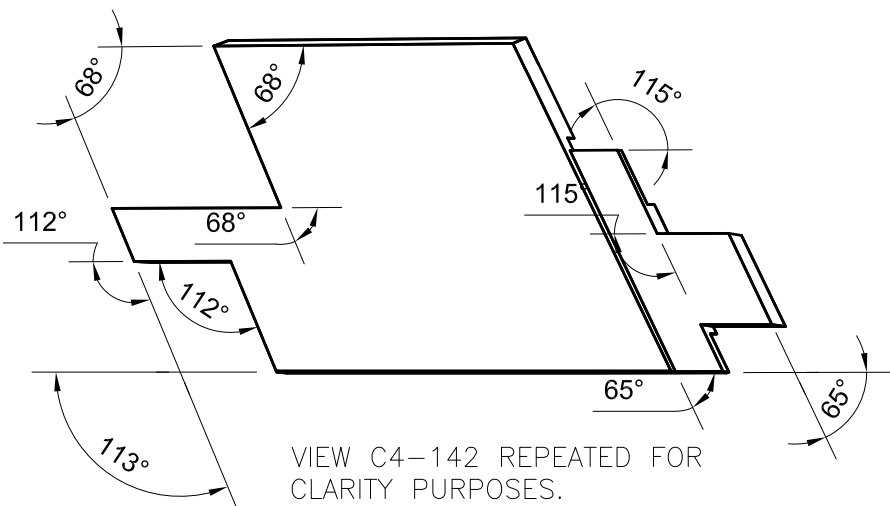

VIEW C4-142 REPEATED FOR CLARITY PURPOSES.

	DRAWING NUMBER				
	AES-D0008				
SIZE	SCALE	SHEET	OF	REVISION	
A3	NONE	142	190	B	

284

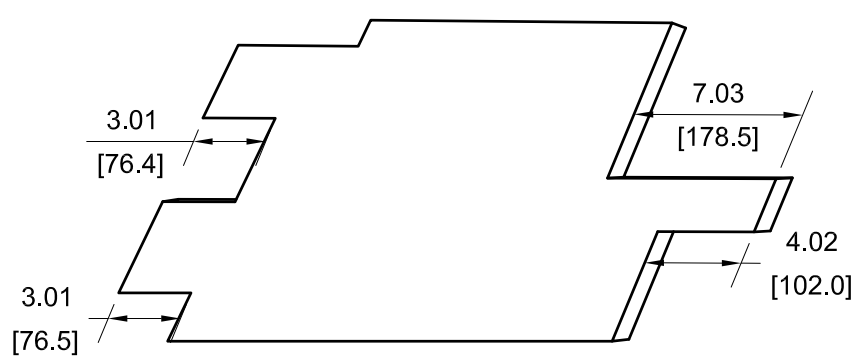

REAR VIEW RELATIVE TO VIEW D4-144

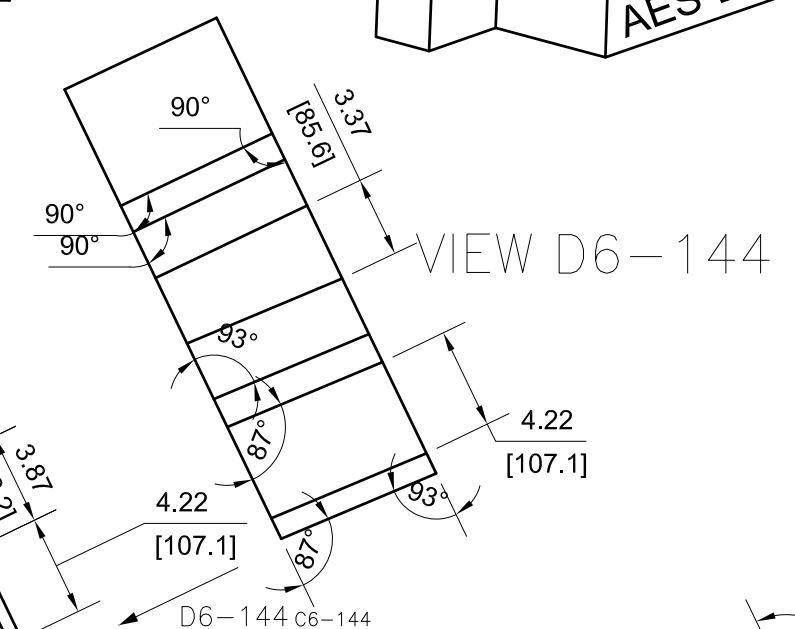
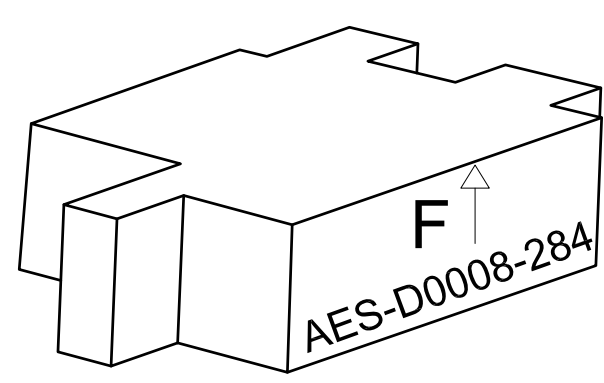
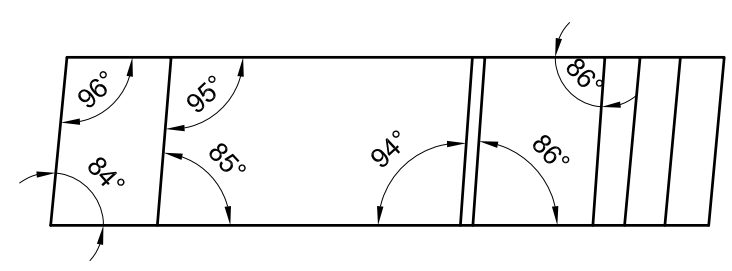

VIEW D6-144

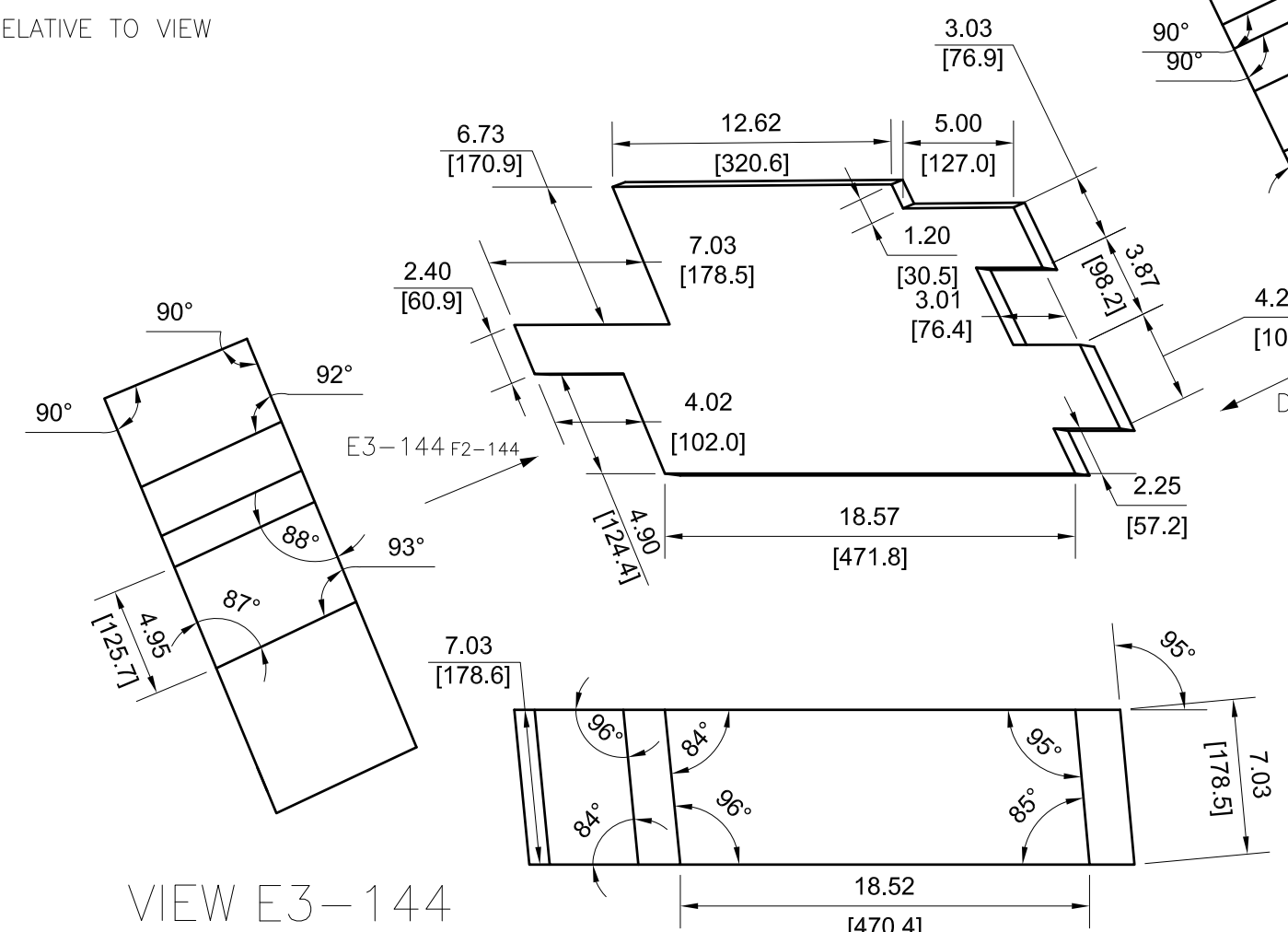

VIEW E3-144

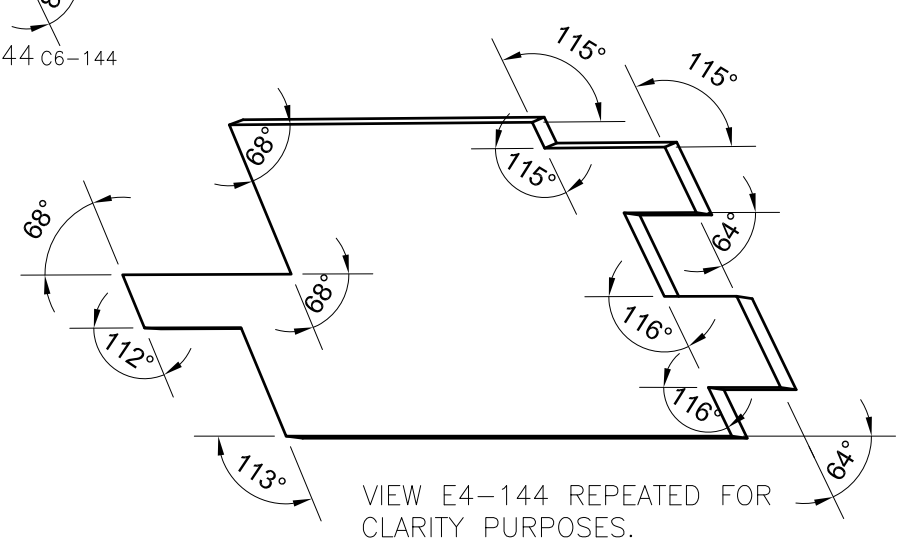

VIEW E4-144 REPEATED FOR CLARITY PURPOSES.



DRAWING NUMBER				
AES-D0008				
SIZE	SCALE	SHEET	OF	REVISION
A3	NONE	144	190	B

- 286

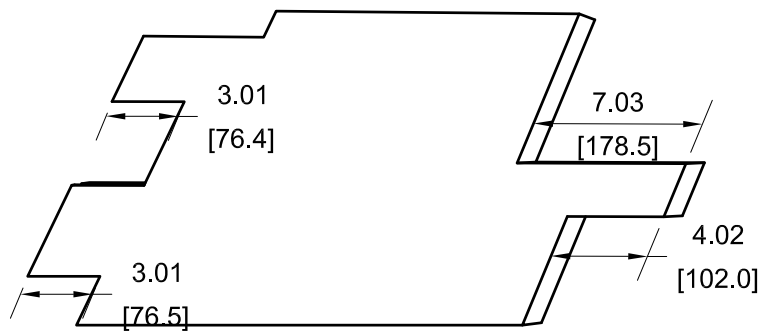

REAR VIEW RELATIVE TO VIEW D4-145

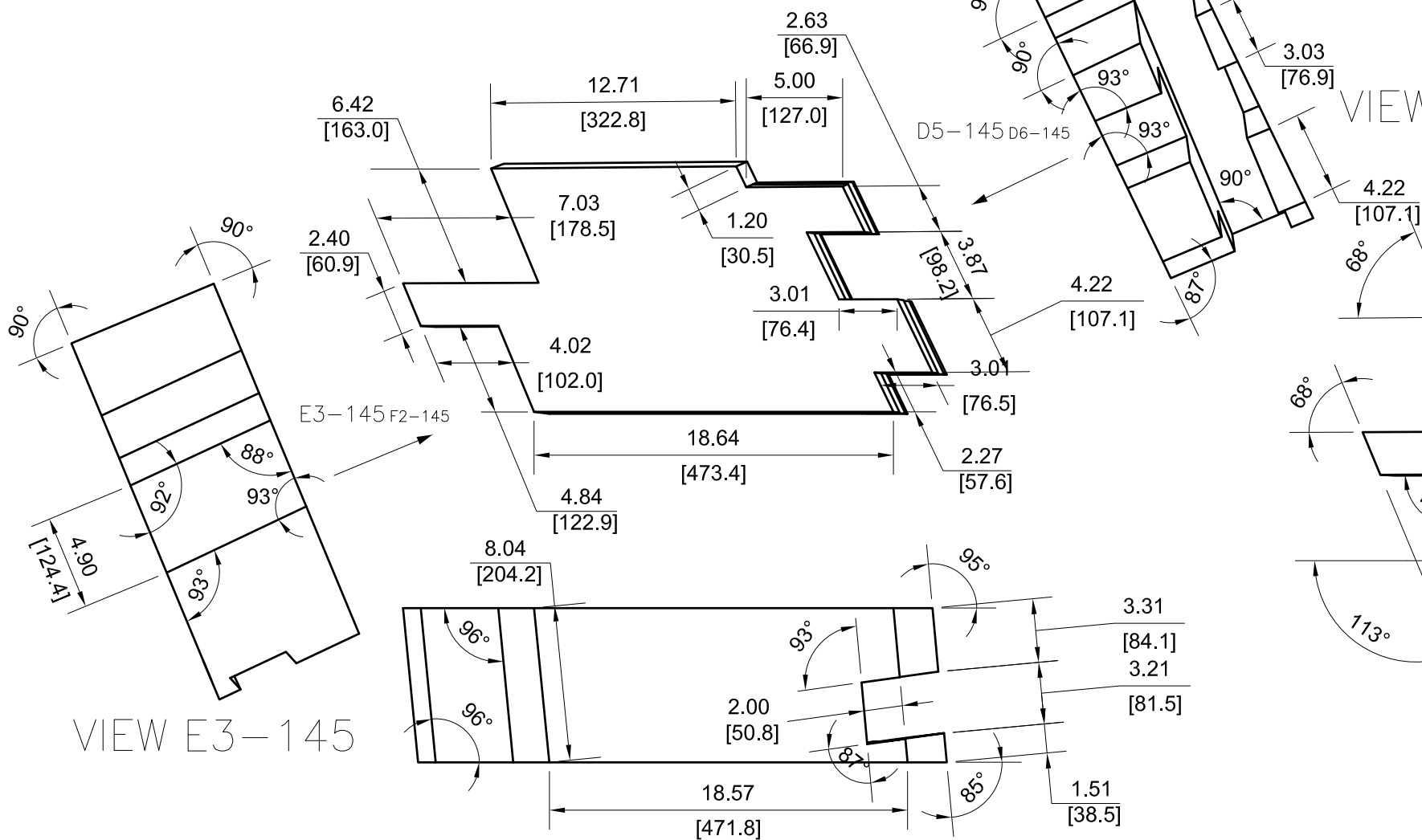
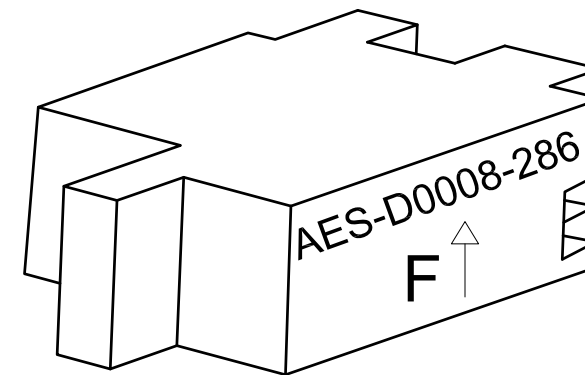
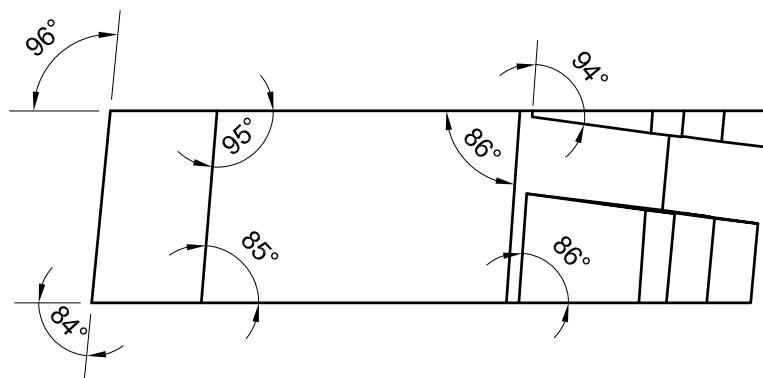

VIEW D5-145

VIEW E4-145 REPEATED FOR CLARITY PURPOSES.



DRAWING NUMBER				
AES-D0008				
SIZE	SCALE	SHEET	OF	REVISION
A3	NONE	145	190	B

— 288

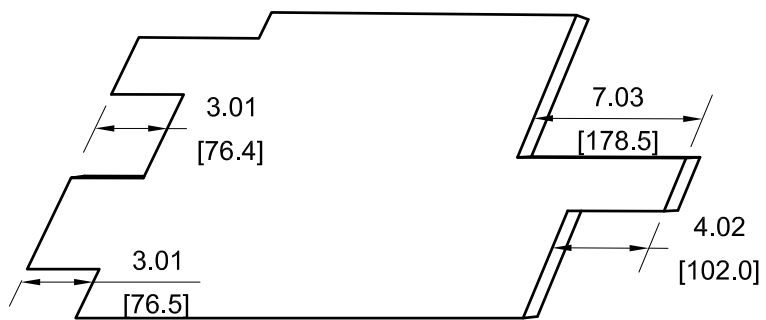

REAR VIEW RELATIVE TO VIEW D4-146

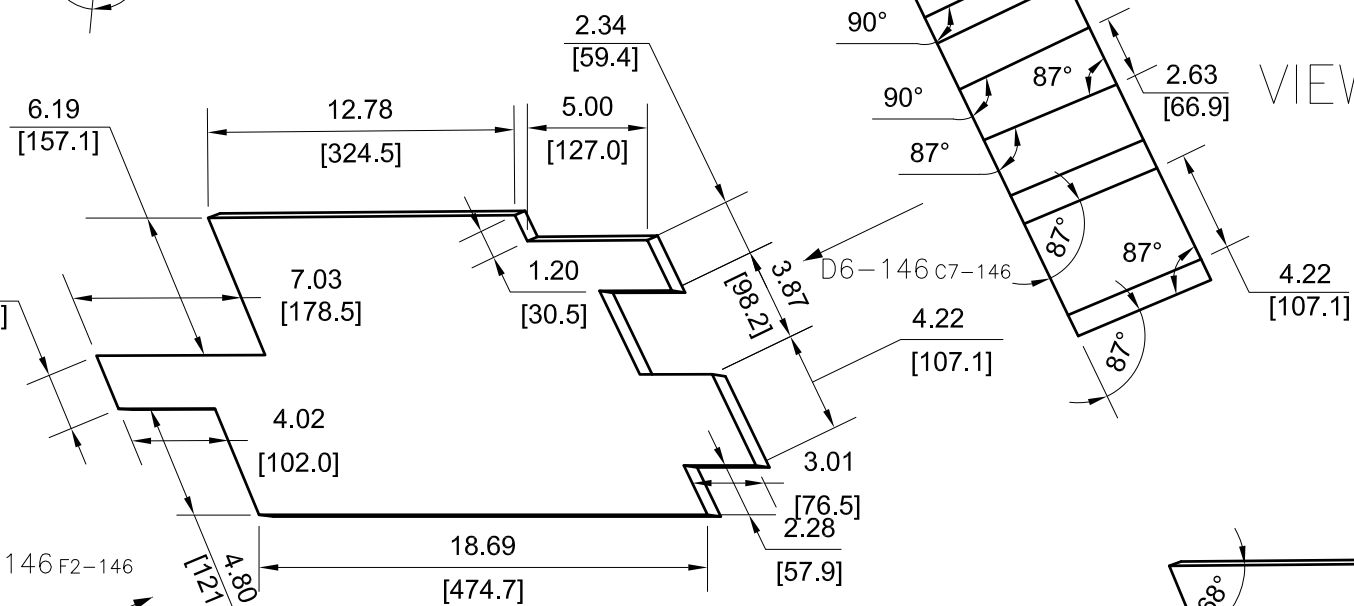
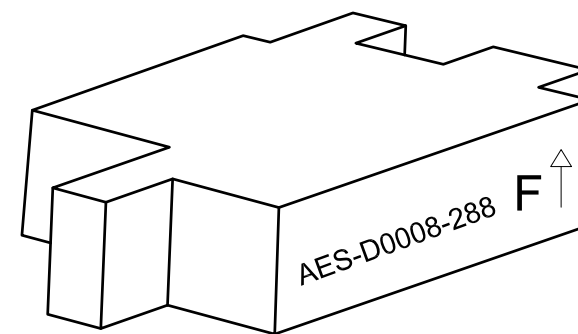
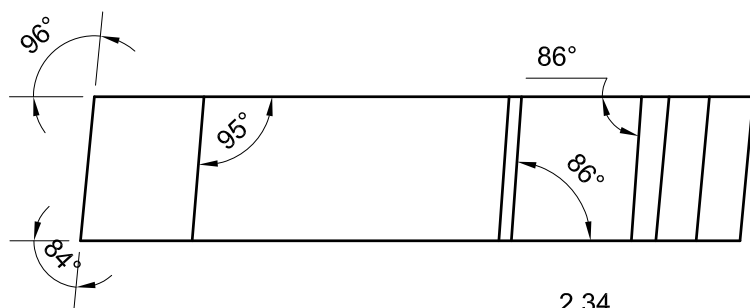

VIEW D6-146

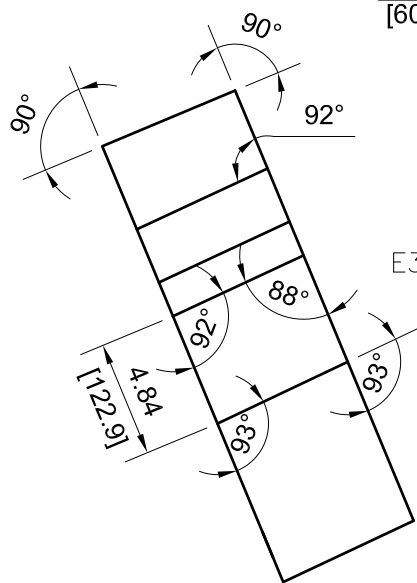

VIEW E3-146

E3-146 F2-146

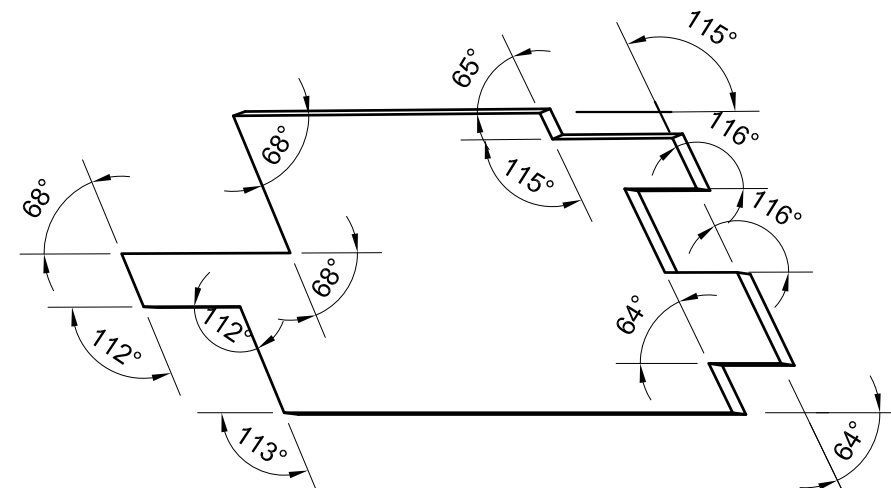
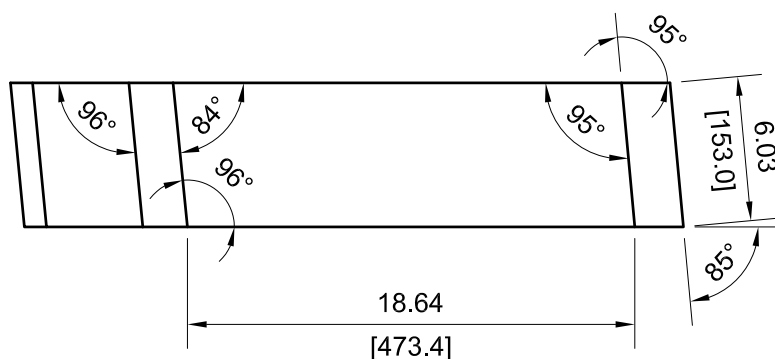

VIEW D4-146 REPEATED FOR CLARITY PURPOSES.



DRAWING NUMBER					AES-D0008				
SIZE	SCALE	SHEET	OF	REVISION					
A3	NONE	146	190	B					

290

VIEW 1E3-147

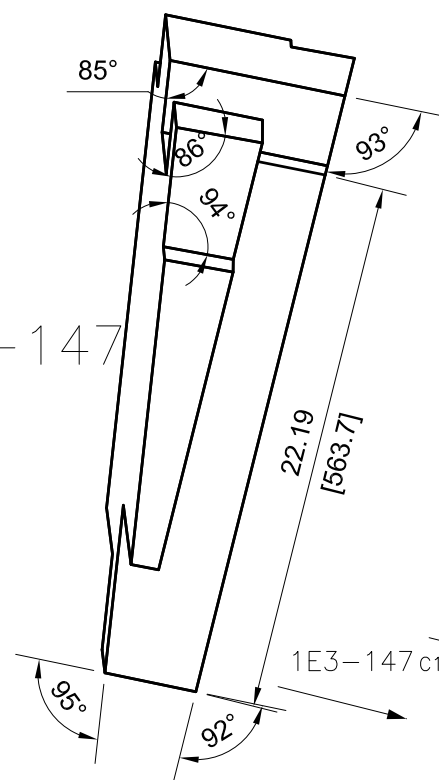

VIEW 2E3-147

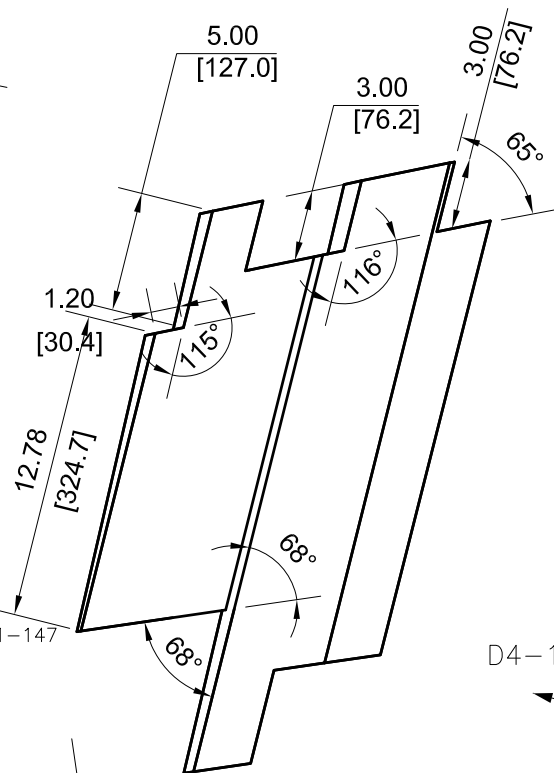

VIEW D4-147

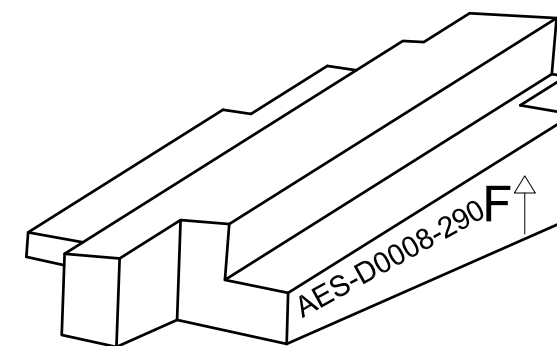
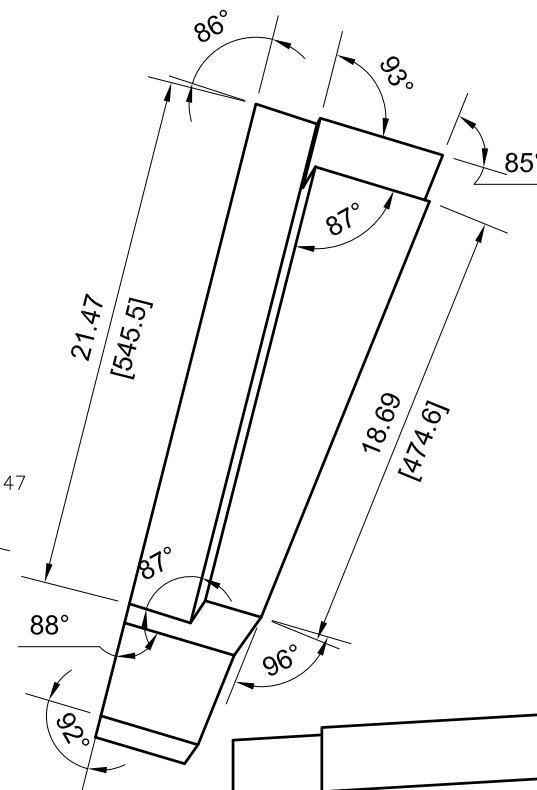

2E3-147 C1-147

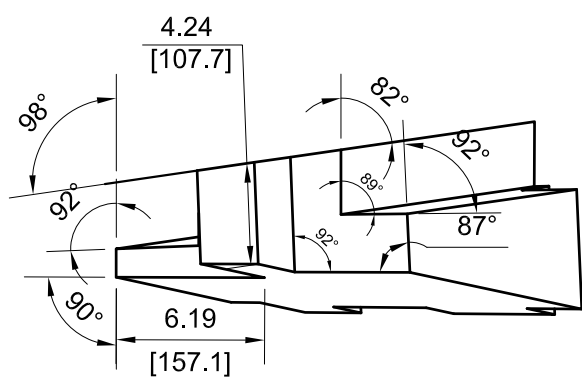
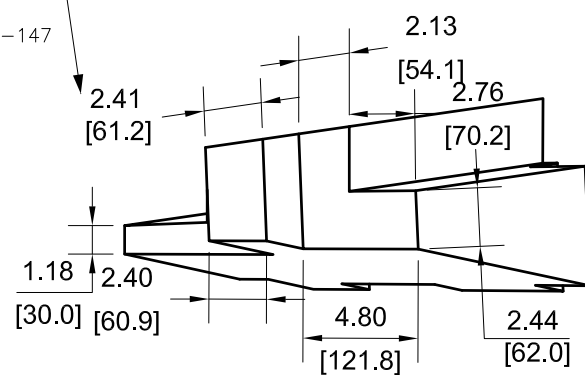

VIEW E4-147 REPEATED FOR CLARITY PURPOSES.



DRAWING NUMBER				
AES-D0008				
SIZE	SCALE	SHEET	OF	REVISION
A3	NONE	147	190	B

292

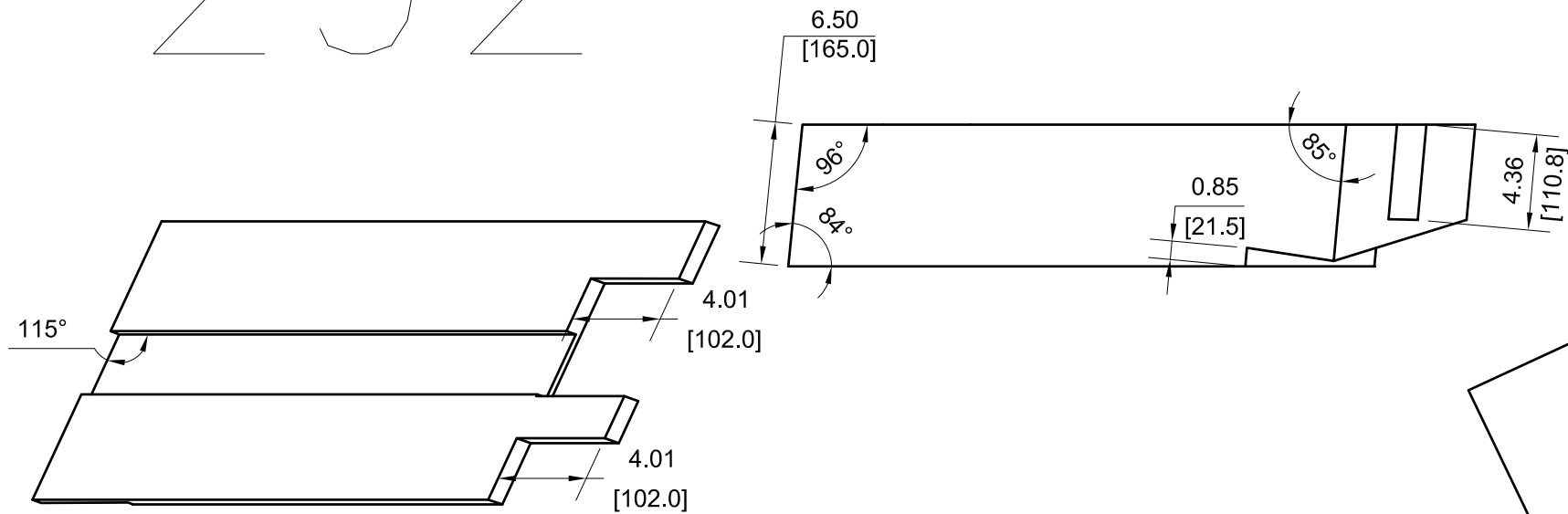

REAR VIEW RELATIVE TO VIEW D4-148

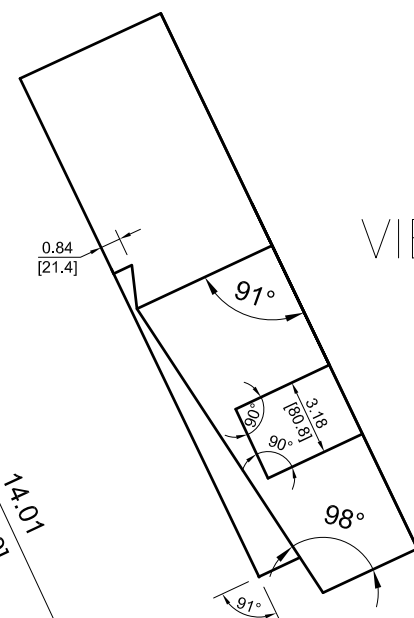
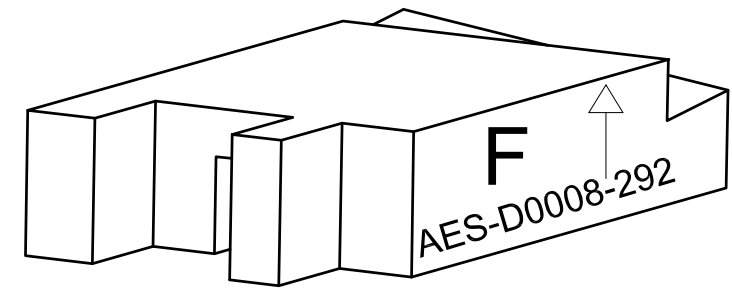

VIEW E6-148

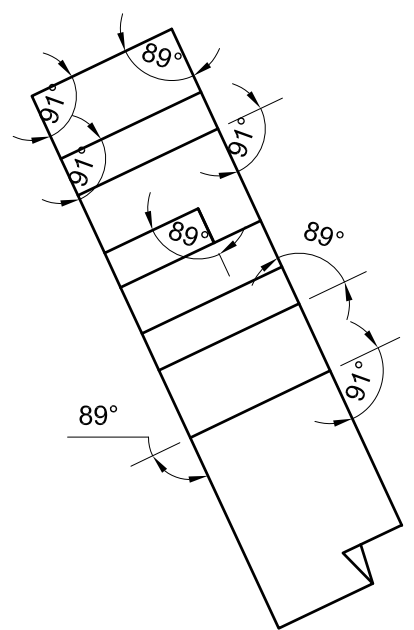

VIEW E3-148

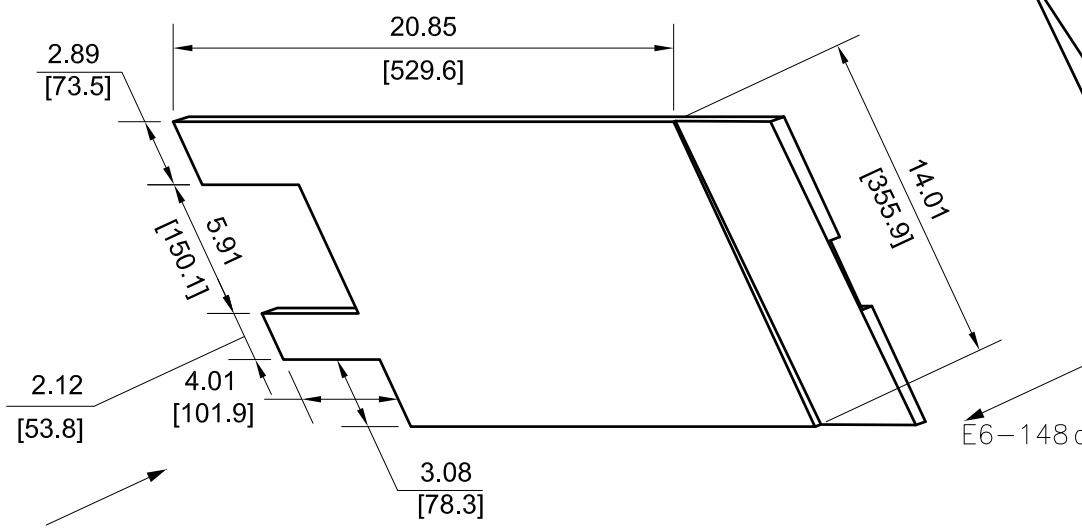

E3-148 F2-148

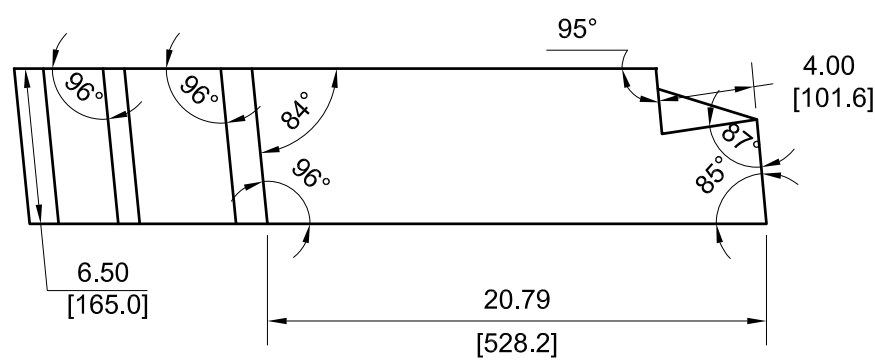

E6-148 C6-148

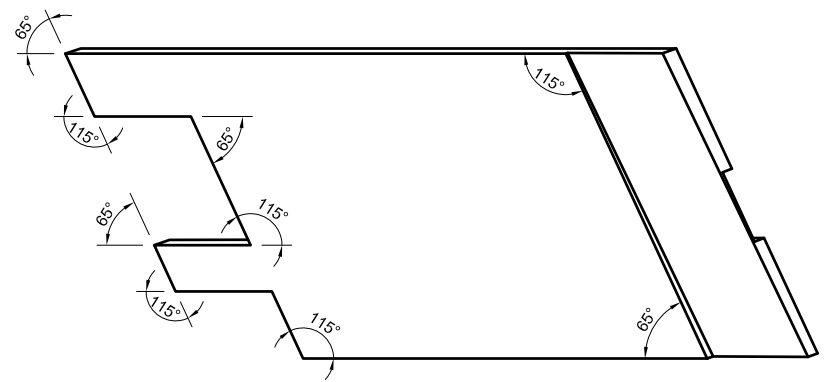

VIEW E4-148 REPEATED FOR CLARITY PURPOSES.



DRAWING NUMBER				
AES-D0008				
SIZE	SCALE	SHEET	OF	REVISION
A3	NONE	148	190	B

— 294

VIEW D4-149

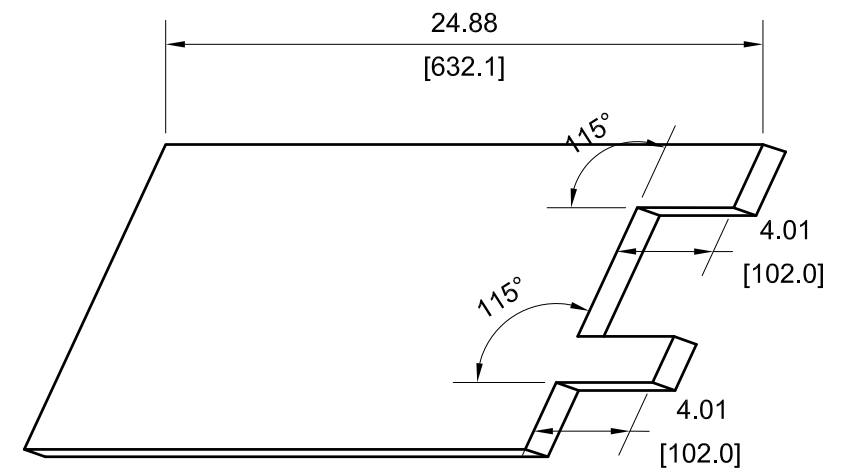
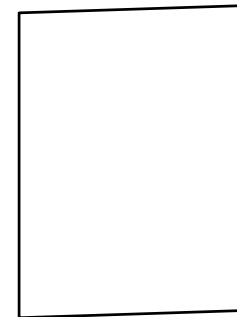
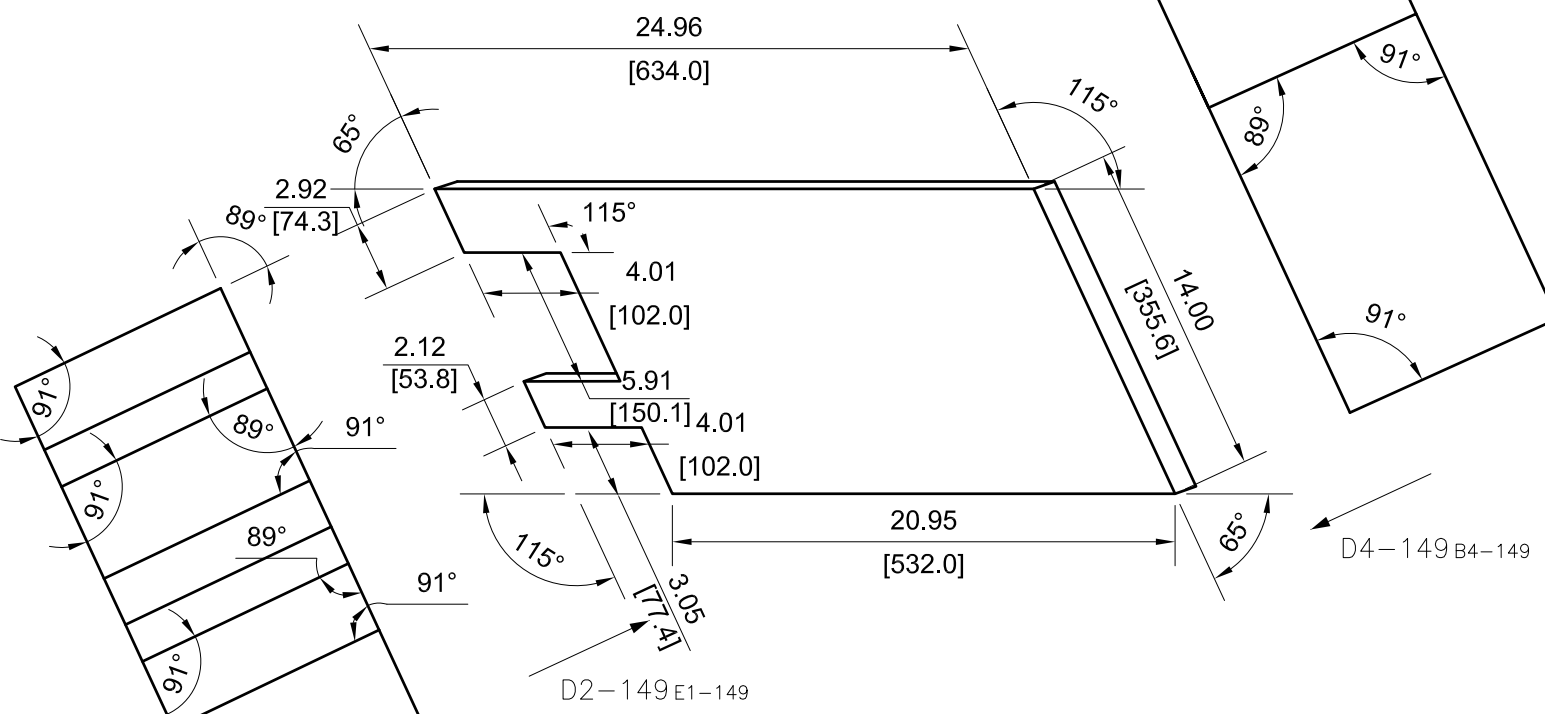
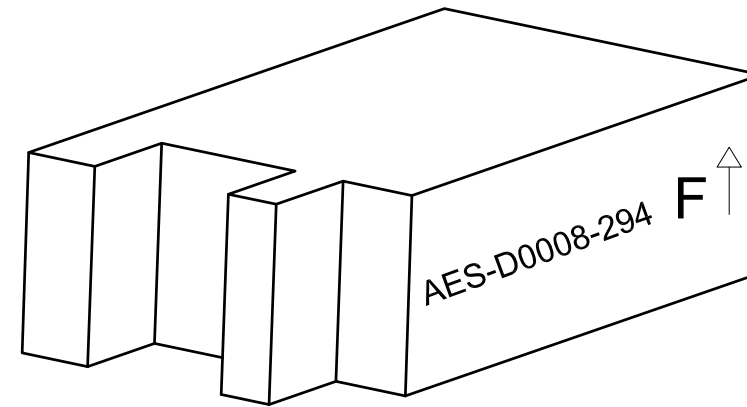

VIEW D2-149

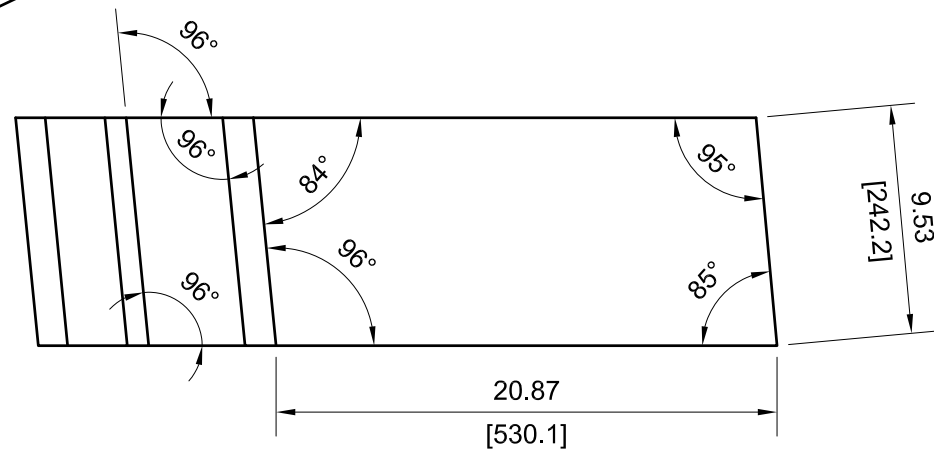

DRAWING NUMBER					AES-D0008	
SIZE	SCALE	SHEET	OF	REVISION		
A3	NONE	149	190	B		

— 296

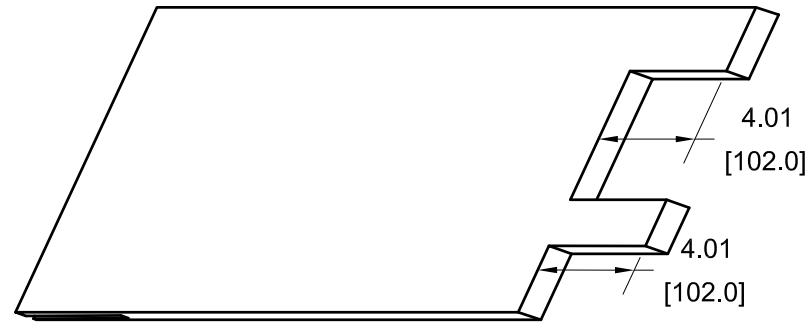
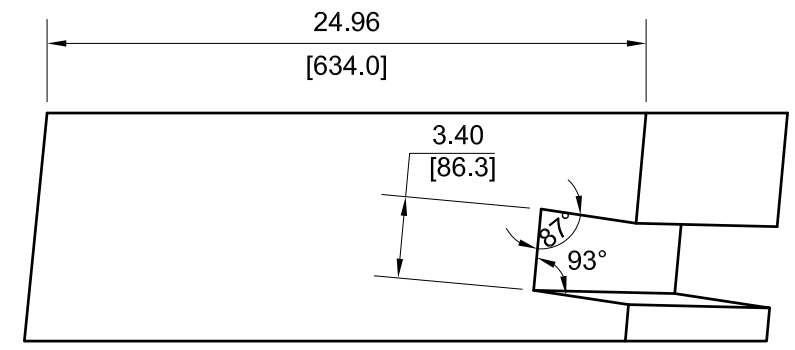
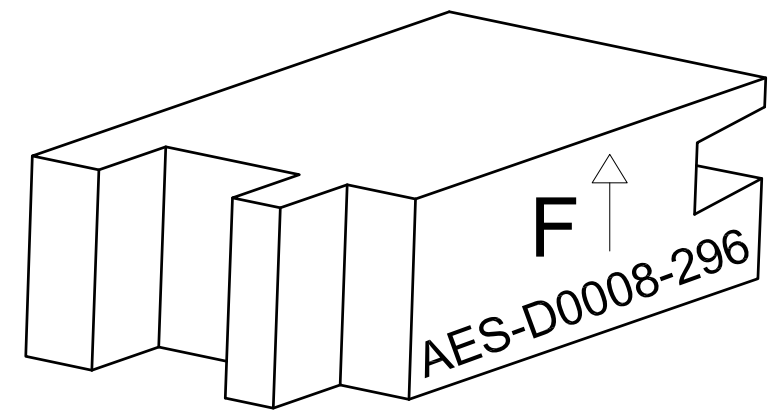

REAR VIEW RELATIVE TO VIEW D4-150

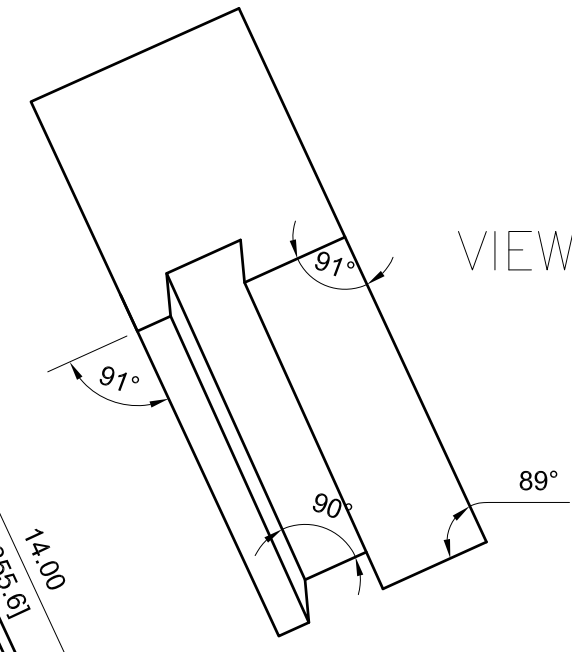

VIEW E6-150

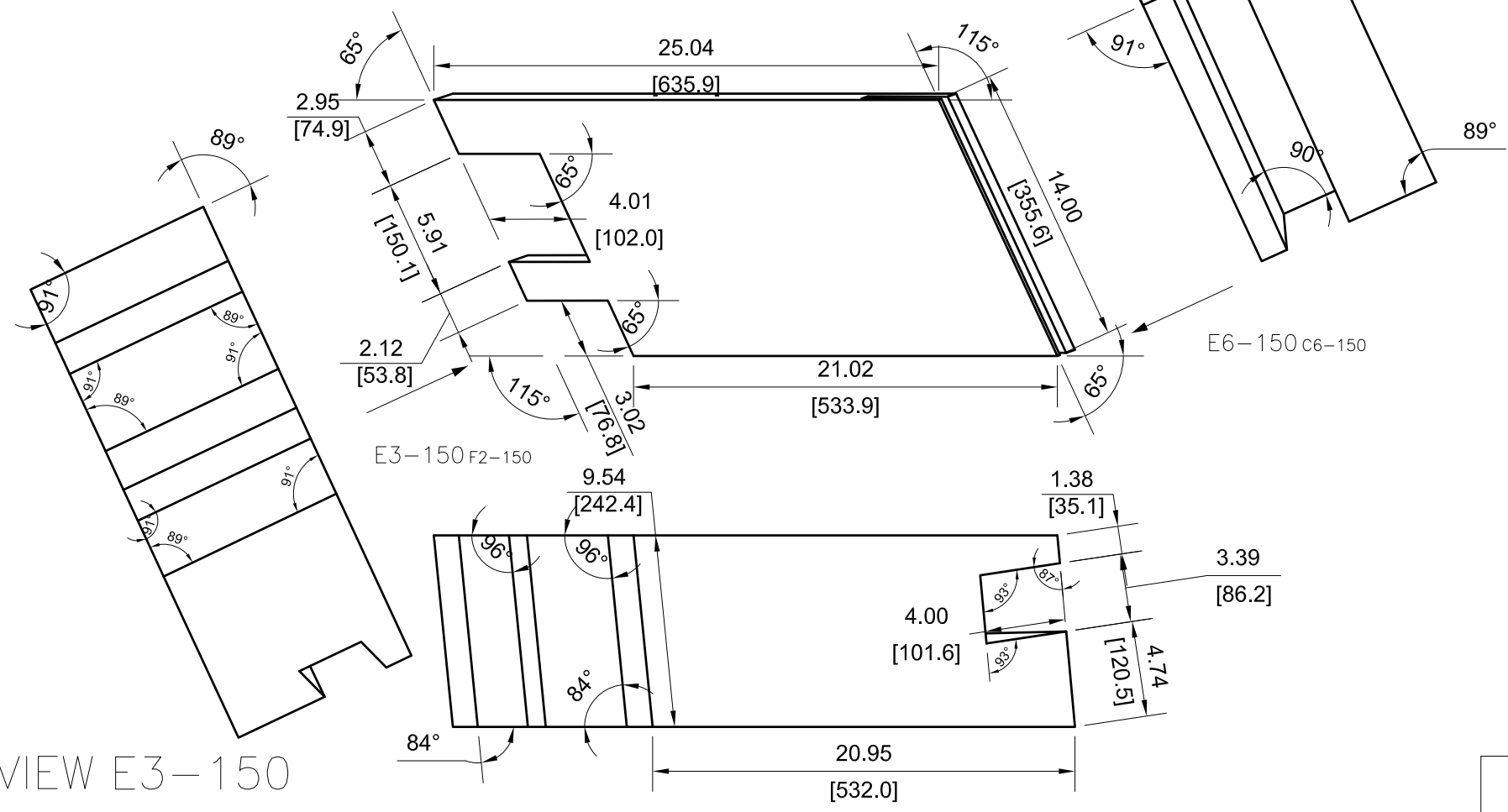

VIEW E3-150

		DRAWING NUMBER			
		AES-D0008			
SIZE	SCALE	SHEET	OF	REVISION	
A3	NONE	150	190	B	

298

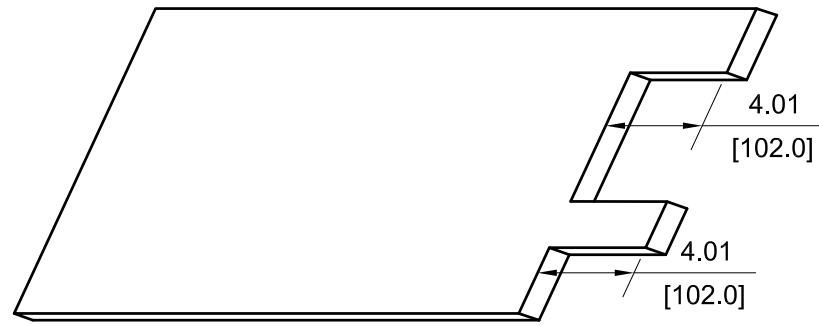

REAR VIEW RELATIVE TO VIEW D4-151

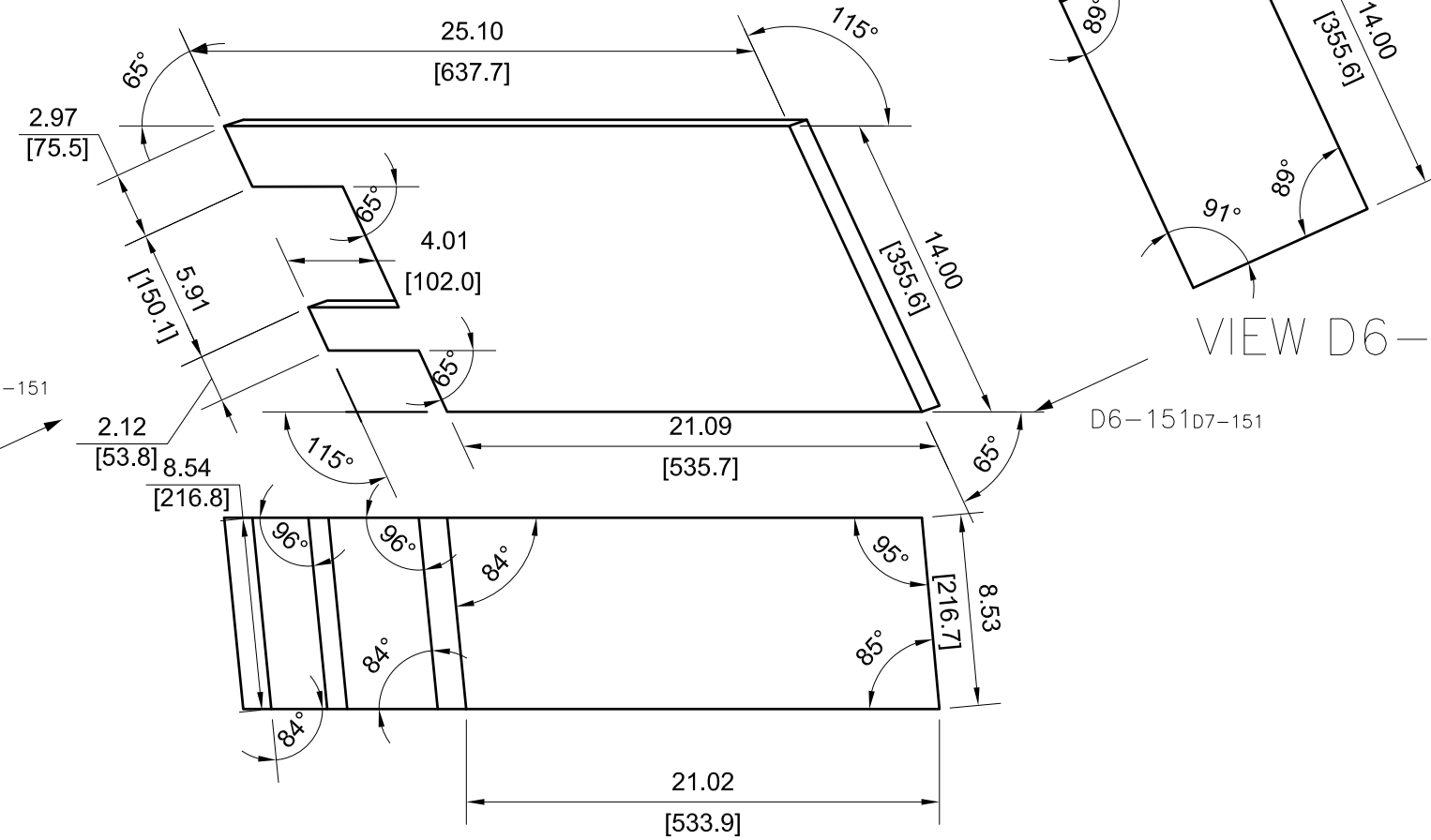
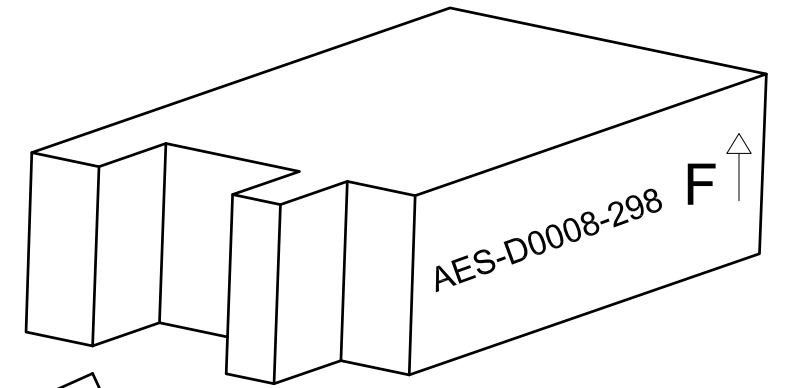
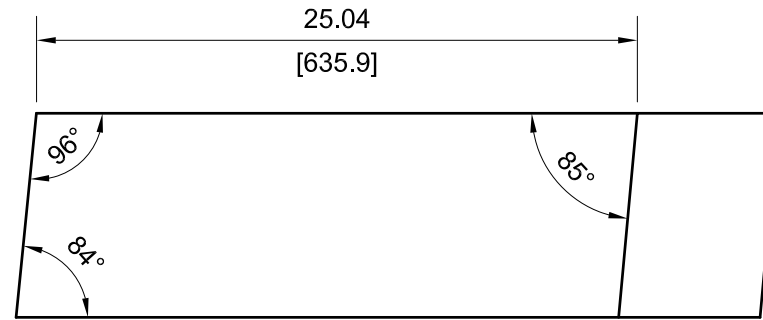

VIEW D6-151

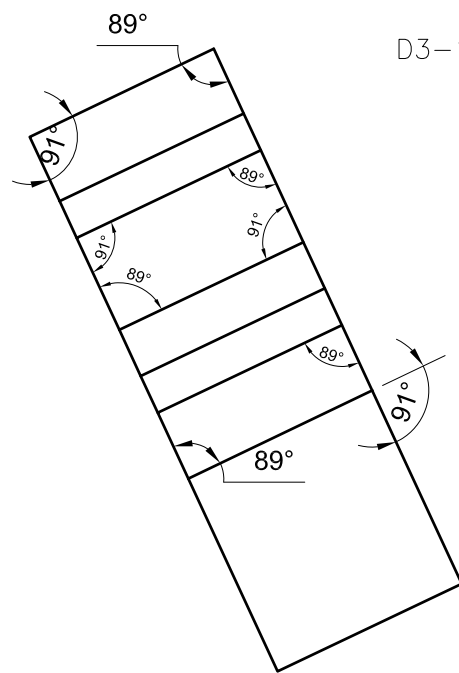

VIEW D3-151

D3-151 F2-151

D6-151 D7-151



DRAWING NUMBER					AES-D0008	
SIZE	SCALE	SHEET	OF	REVISION		
A3	NONE	151	190	B		

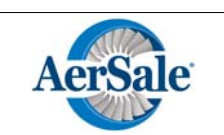
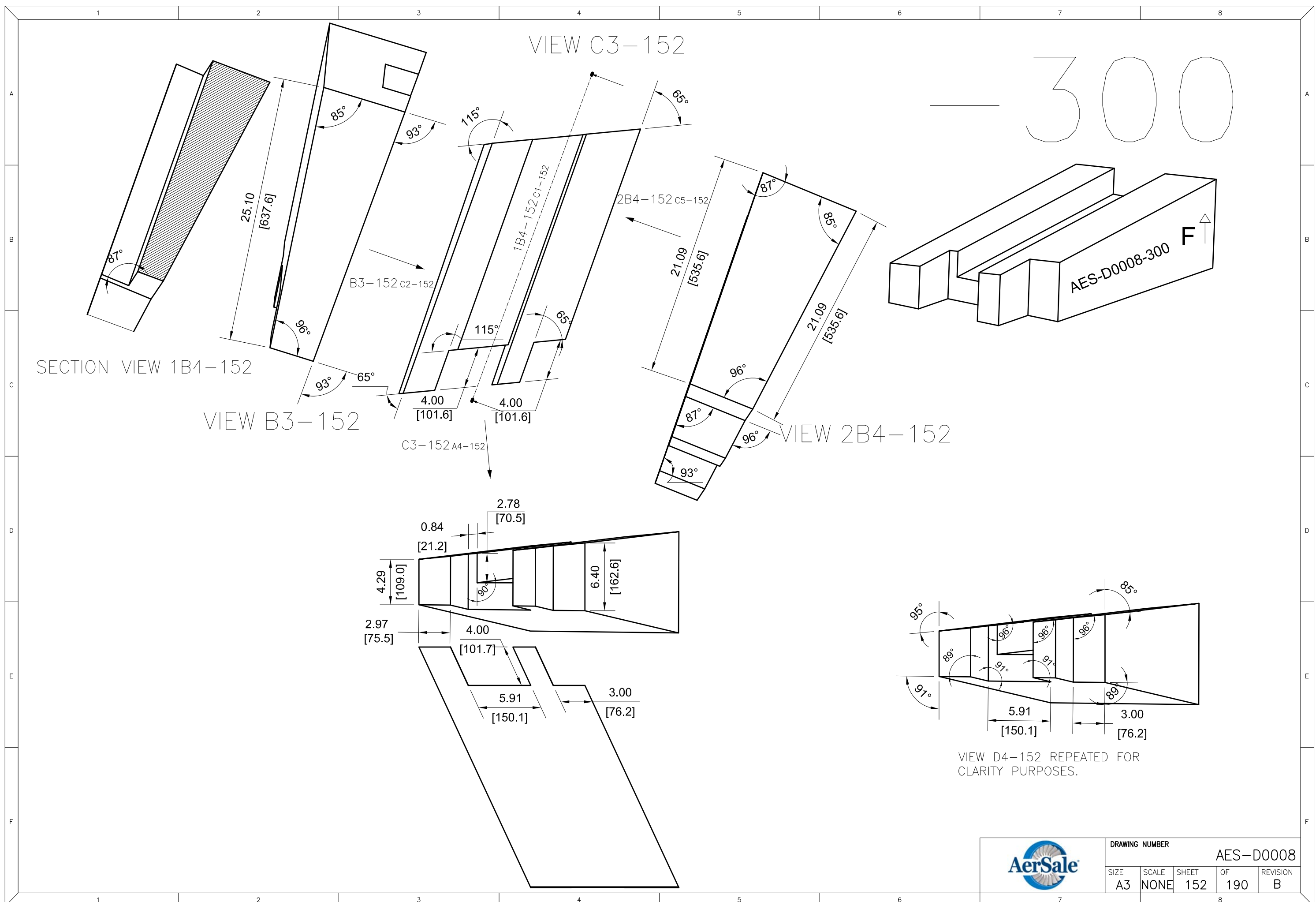

DRAWING NUMBER					AES-D0008	
SIZE	SCALE	SHEET	OF	REVISION		
A3	NONE	152	190	B		

— 302

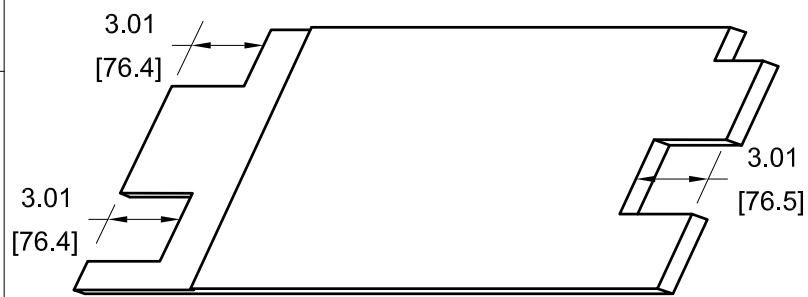
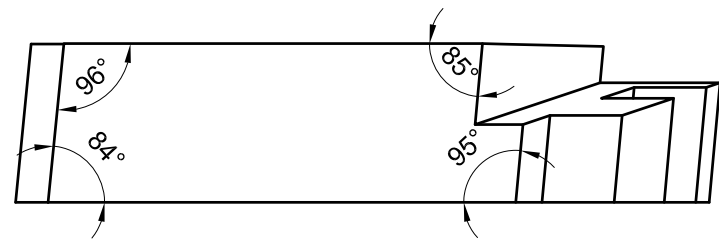
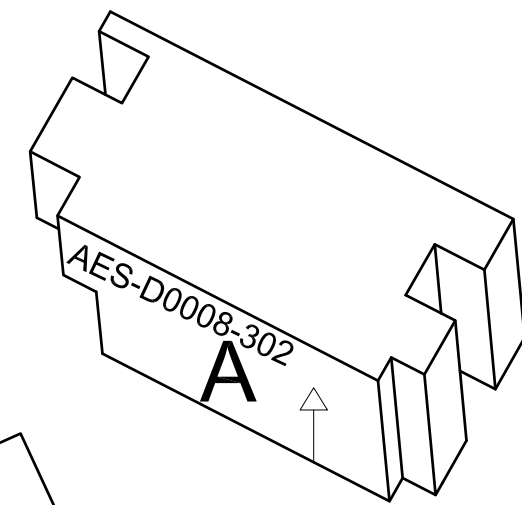

REAR VIEW RELATIVE TO VIEW D4-153

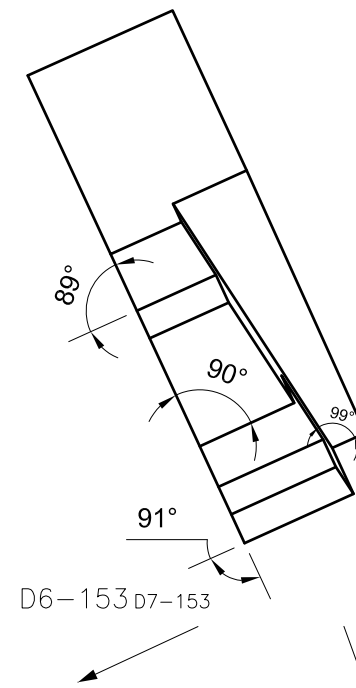

VIEW D6-153

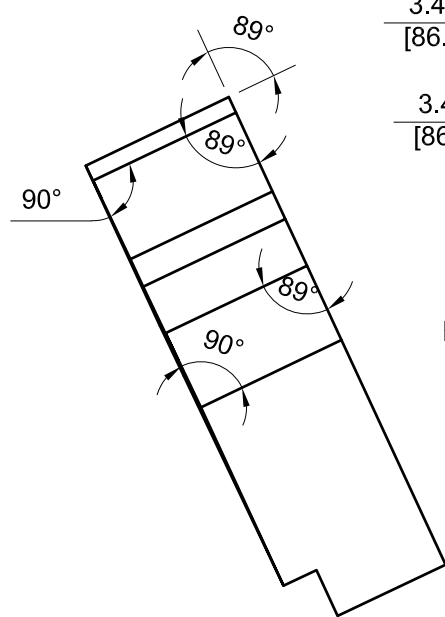

VIEW E3-153

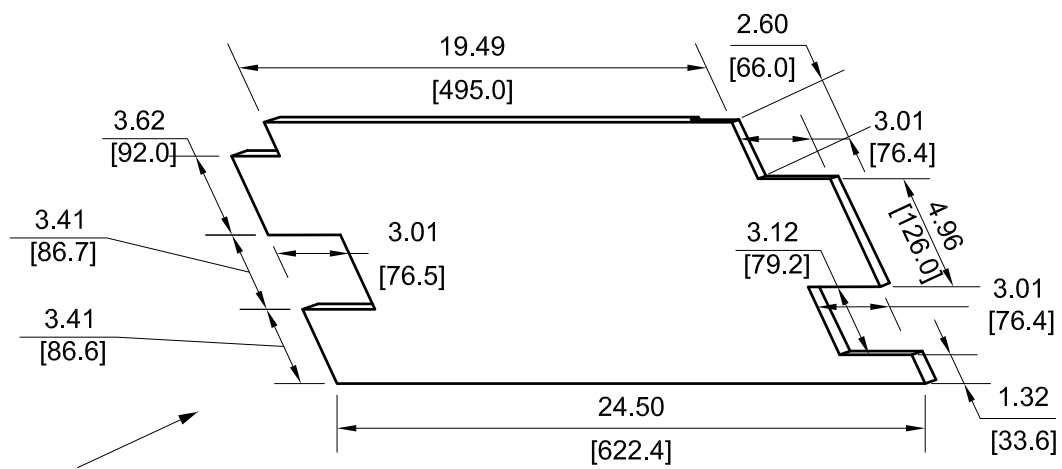

E3-153 F2-153

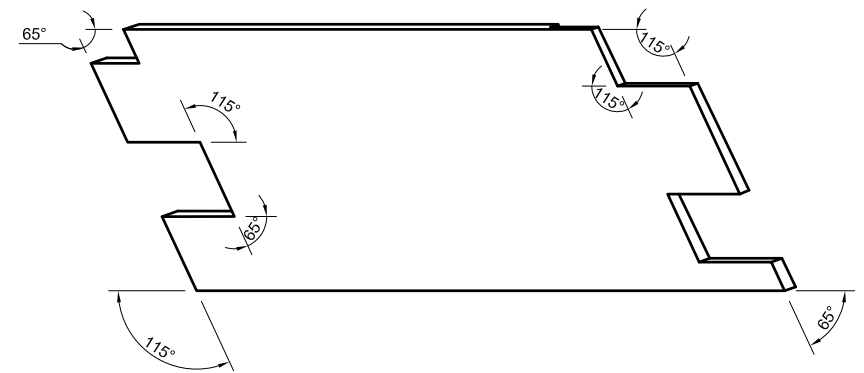
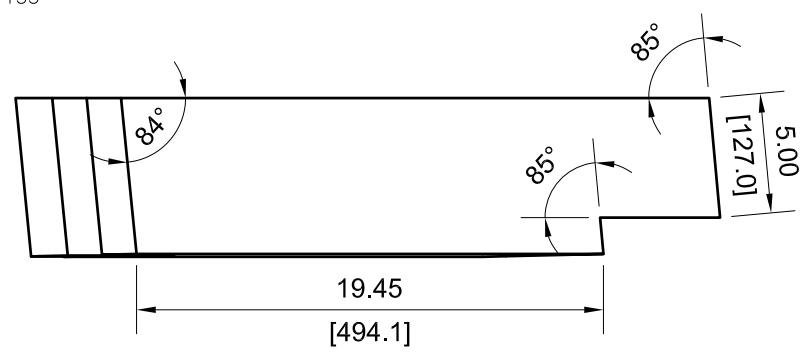

VIEW D4-153 REPEATED FOR CLARITY PURPOSES.



DRAWING NUMBER					AES-D0008	
SIZE	SCALE	SHEET	OF	REVISION		
A3	NONE	153	190	B		

304

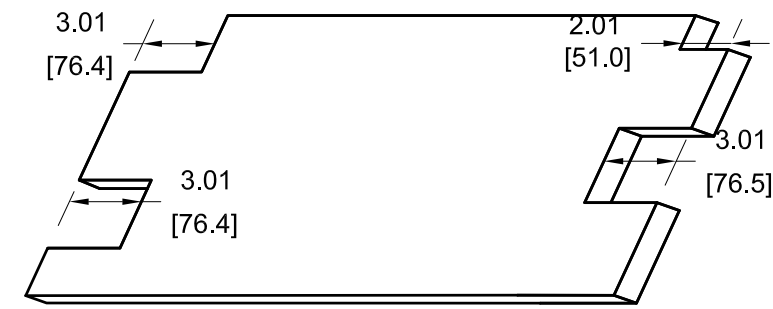
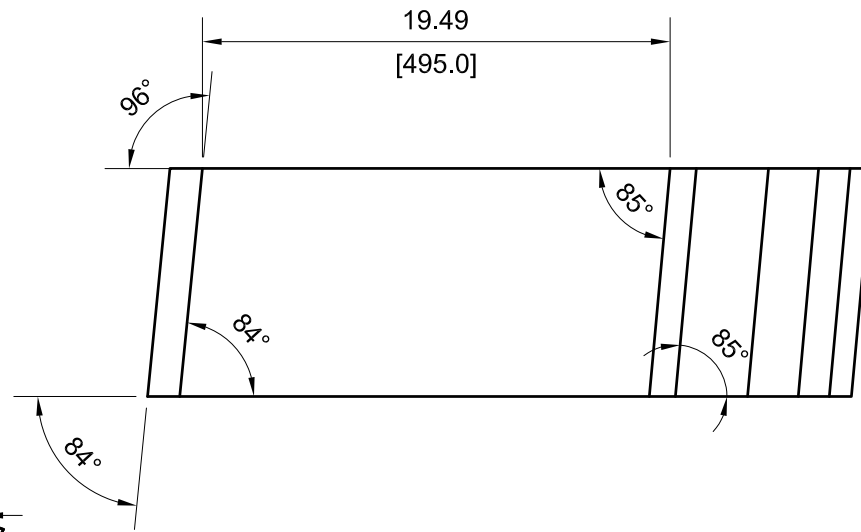

REAR VIEW RELATIVE TO VIEW D4-154

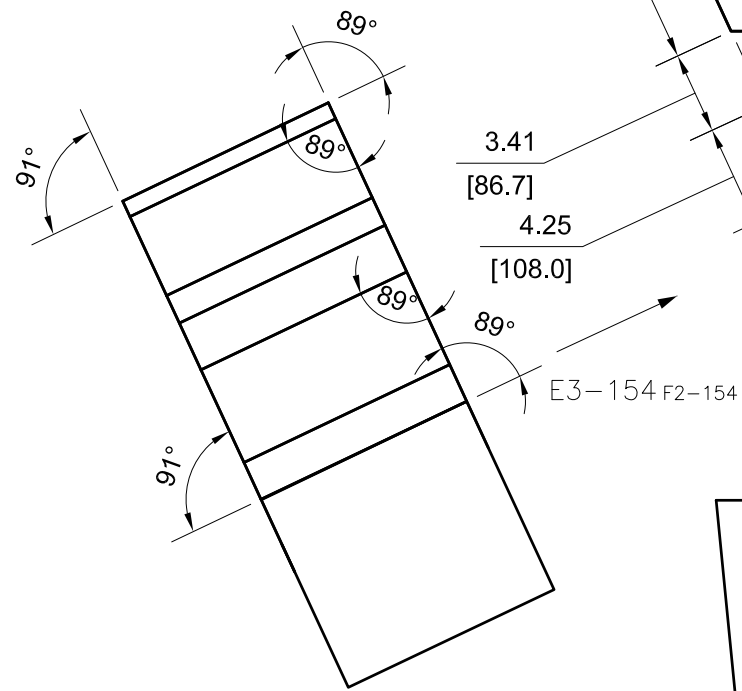

VIEW E3-154

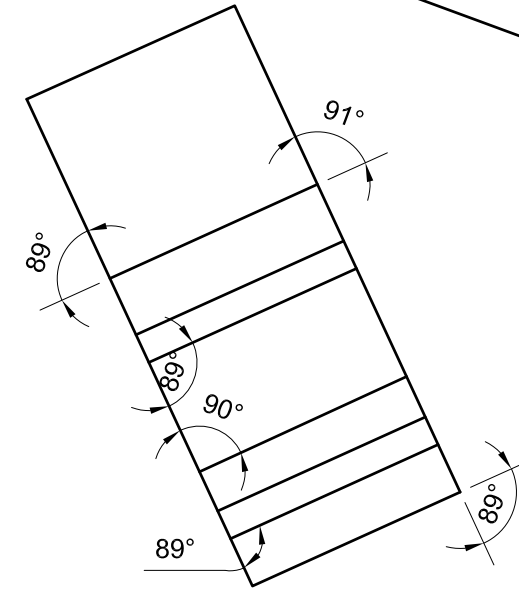
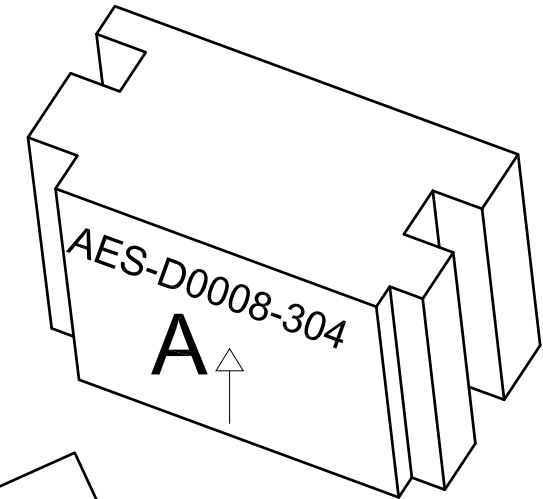
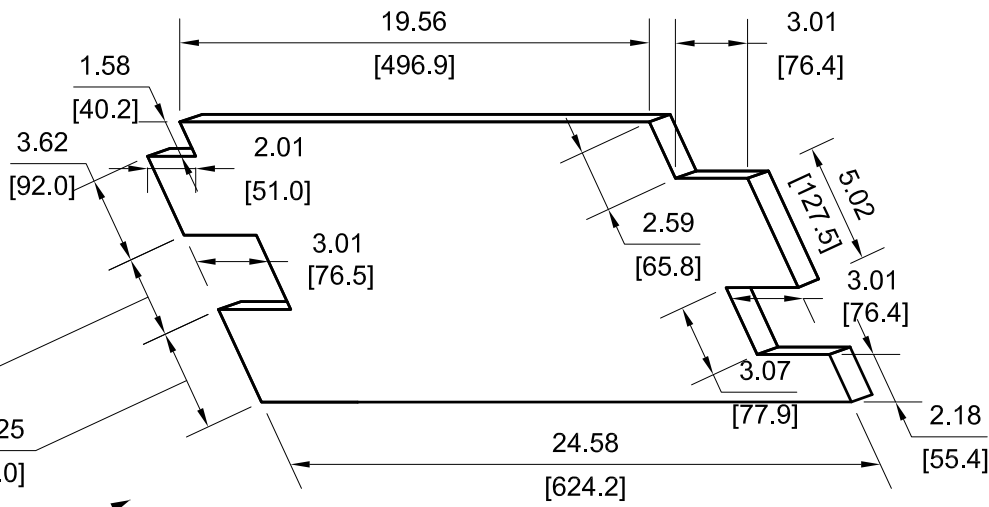

D6-154 D7-154

VIEW D6-154

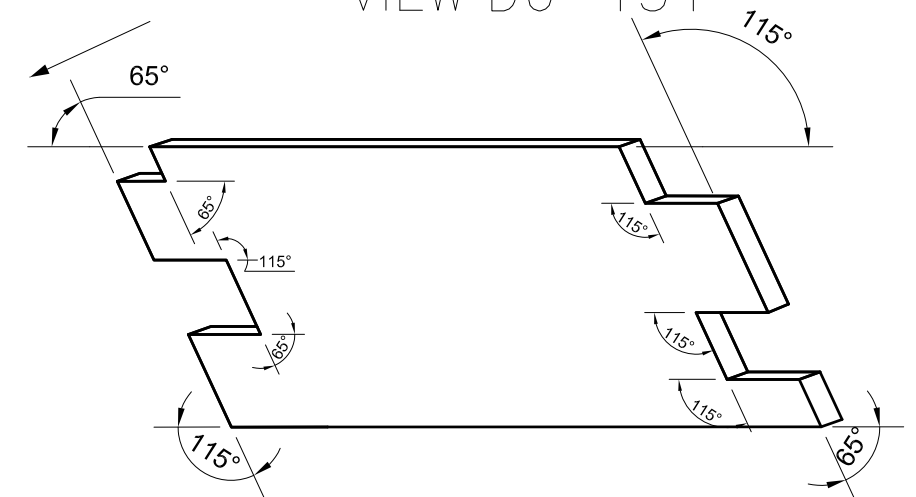

VIEW D4-154 REPEATED FOR CLARITY PURPOSES.



DRAWING NUMBER				
AES-D0008				
SIZE	SCALE	SHEET	OF	REVISION
A3	NONE	154	190	B

- 306

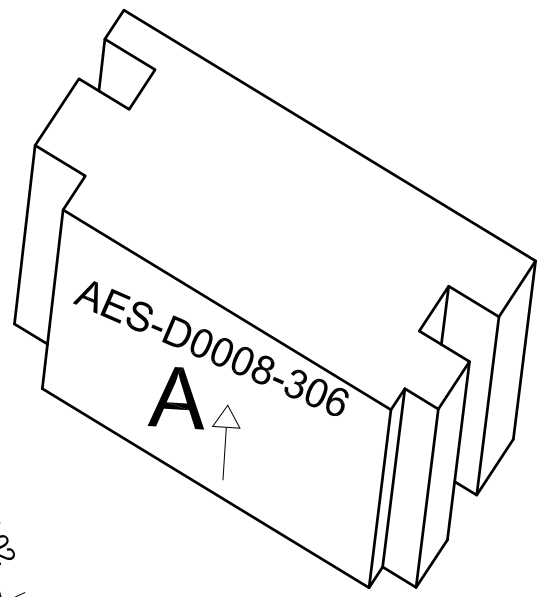
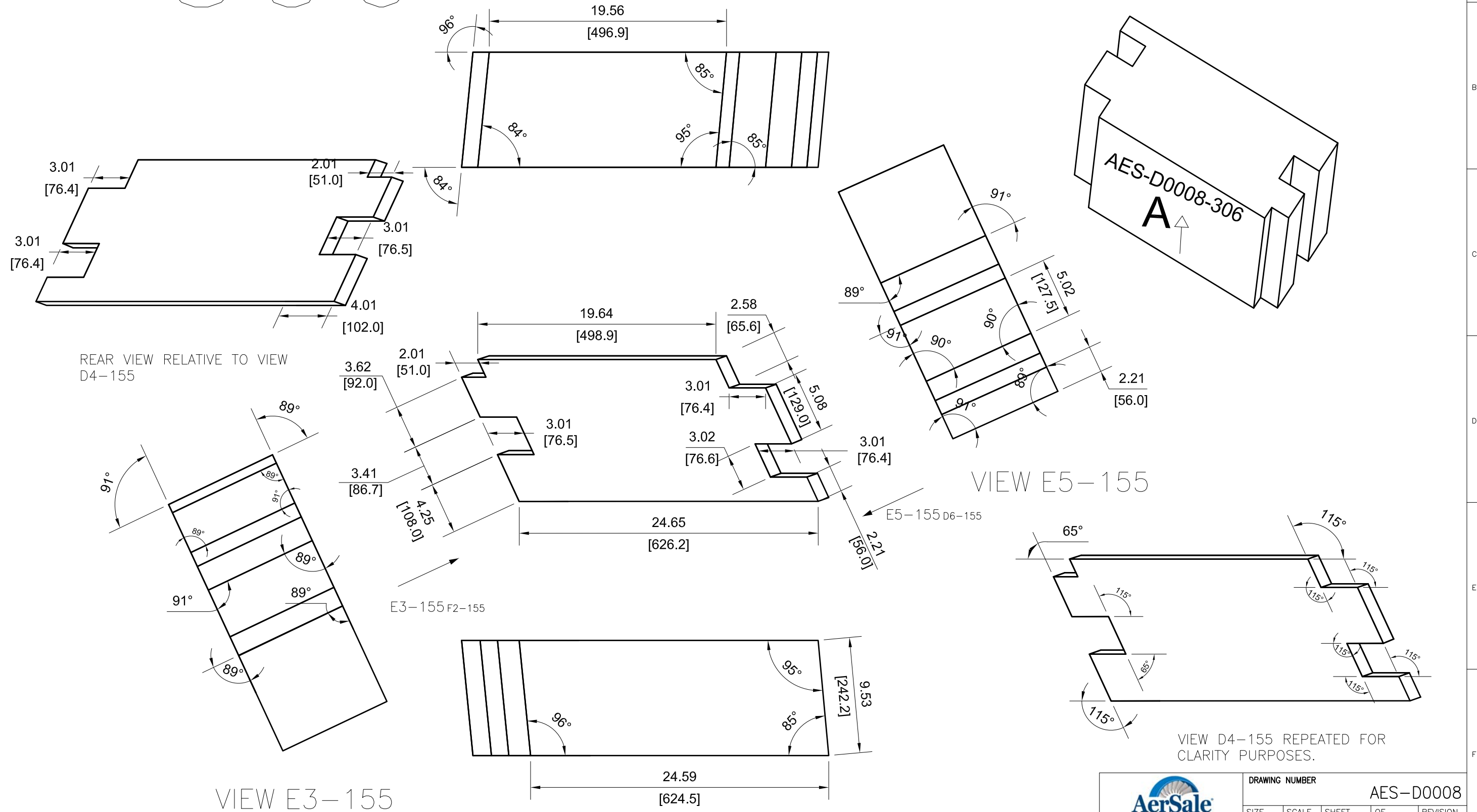

		DRAWING NUMBER			
		AES-D0008			
SIZE	SCALE	SHEET	OF	REVISION	
A3	NONE	155	190	B	

308

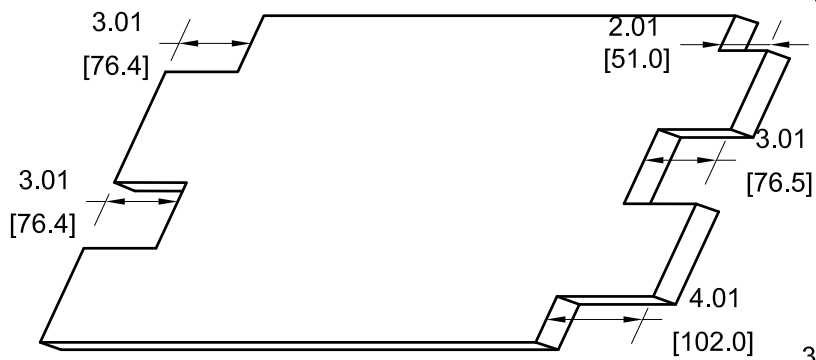
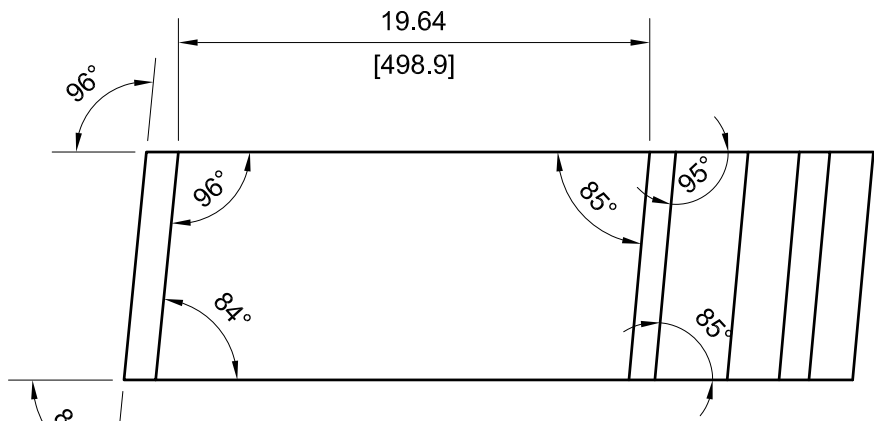
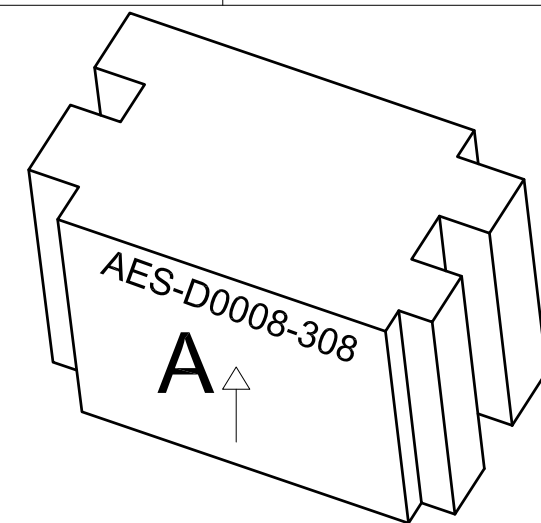

REAR VIEW RELATIVE TO VIEW D4-156

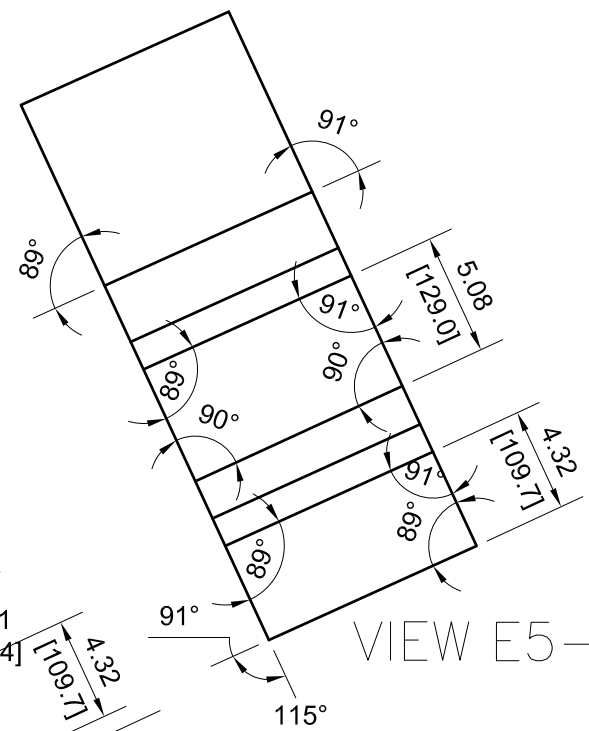
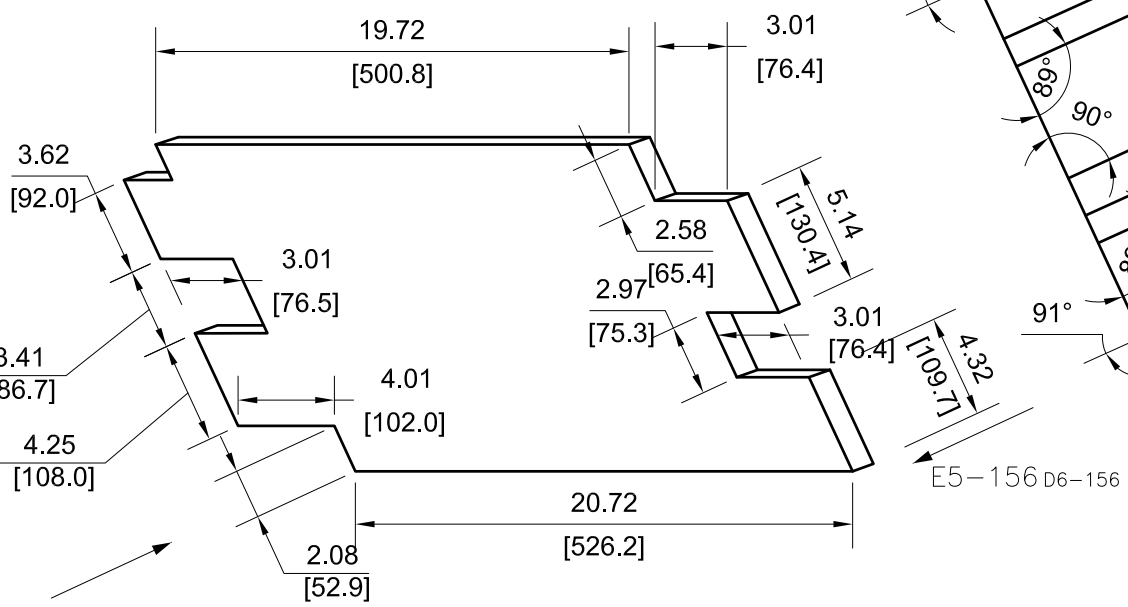

VIEW E5-156

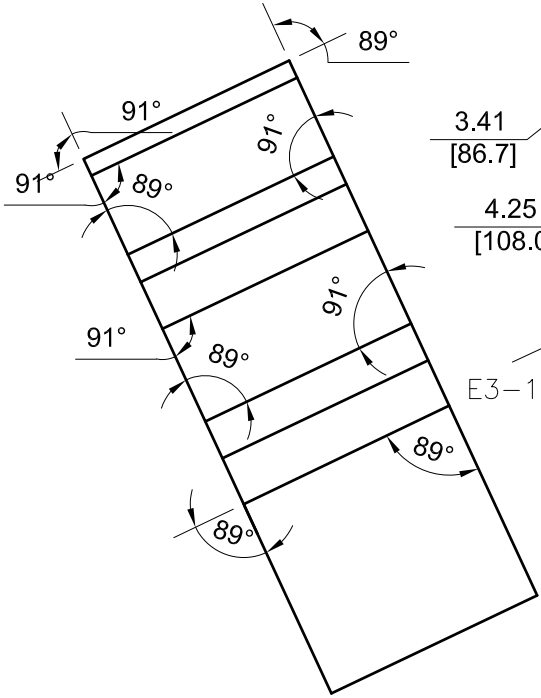

VIEW E3-156

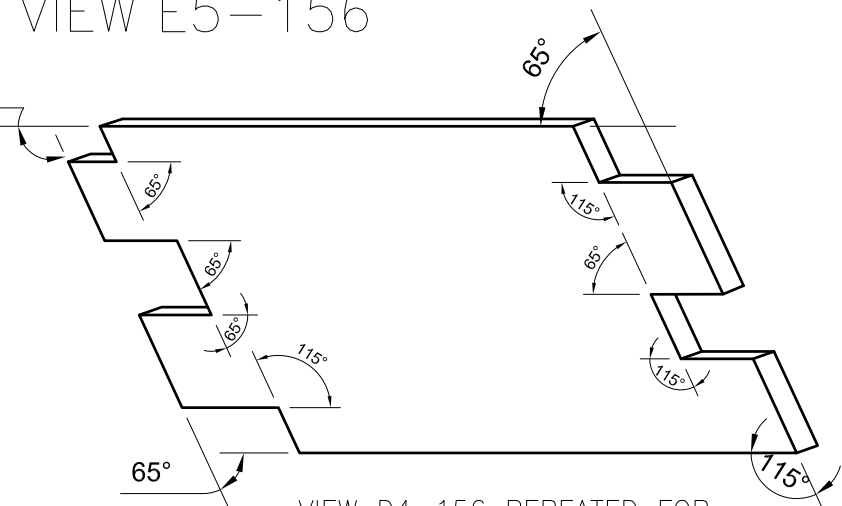
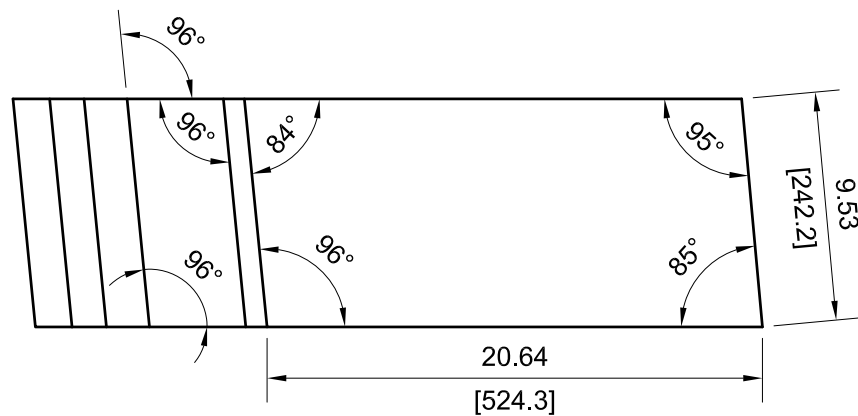

VIEW D4-156 REPEATED FOR CLARITY PURPOSES.



DRAWING NUMBER				
AES-D0008				
SIZE	SCALE	SHEET	OF	REVISION
A3	NONE	156	190	B

310

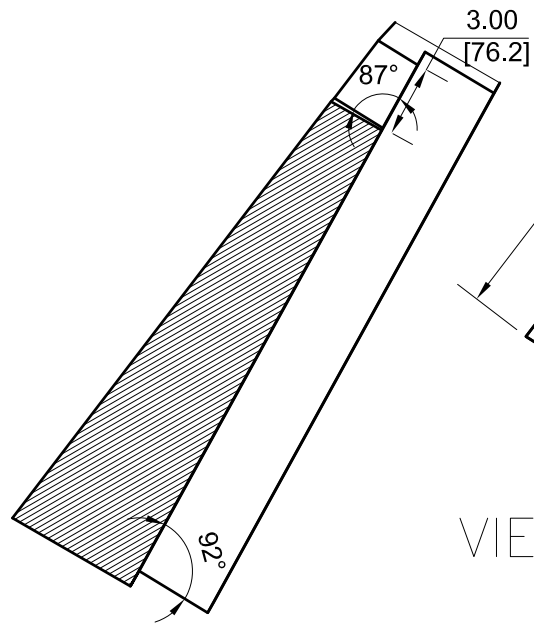

SECTION VIEW B5-157

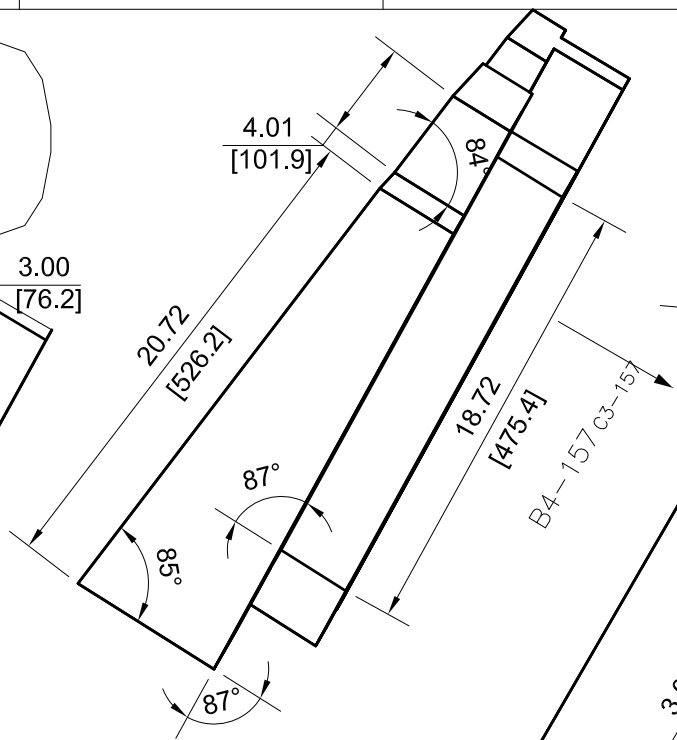

VIEW B4-157

B3-157 A5-157

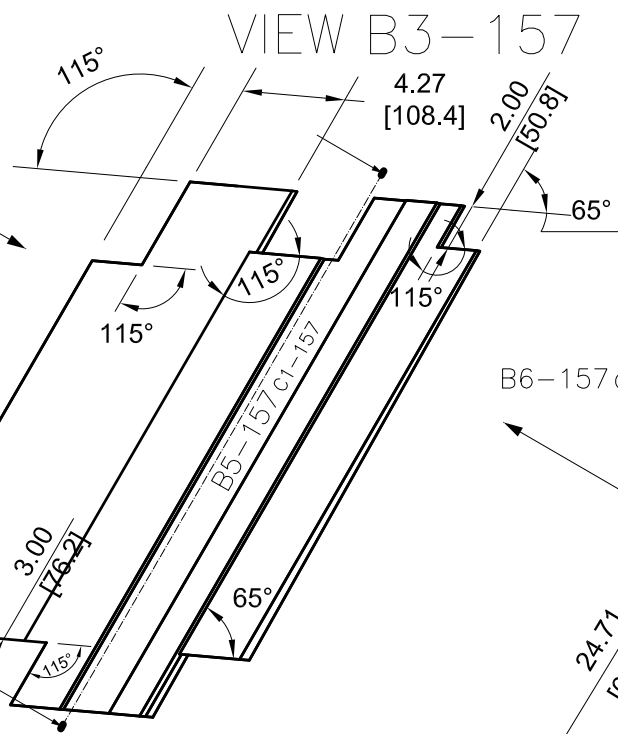

VIEW B3-157

B6-157 C7-157

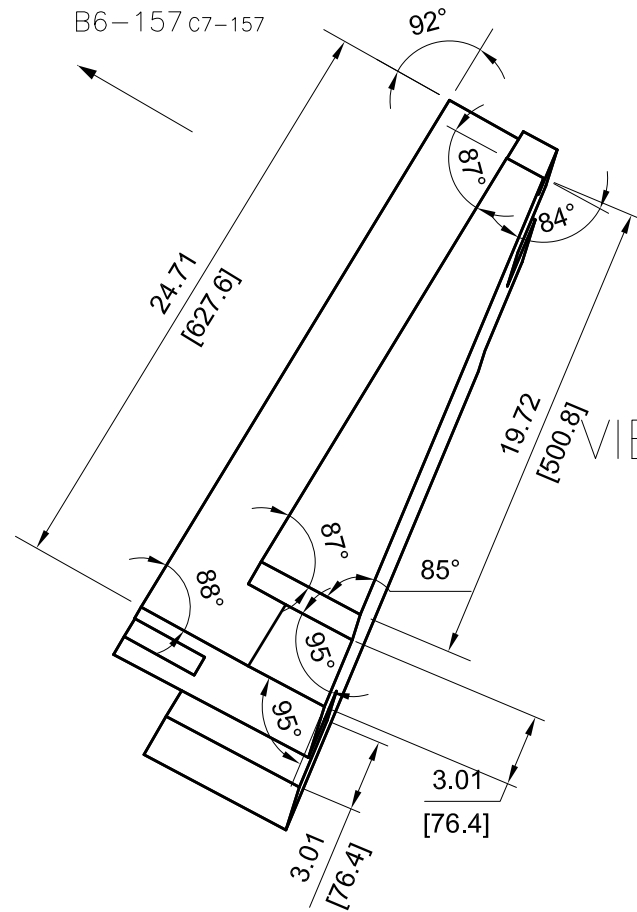

VIEW B6-157

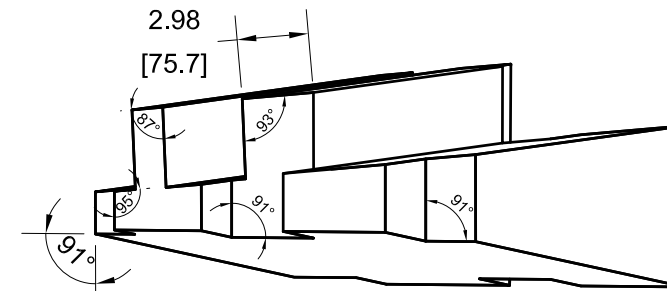
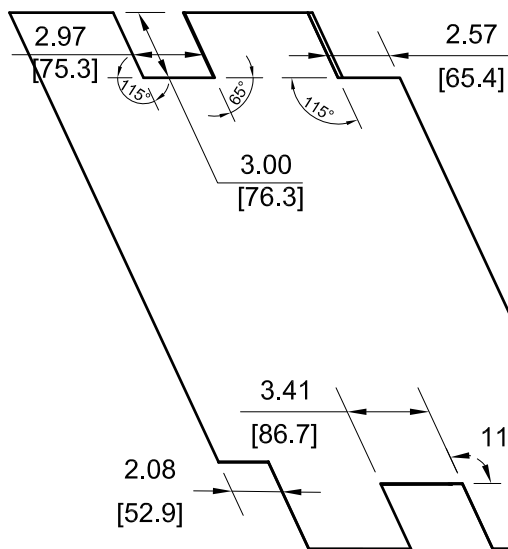
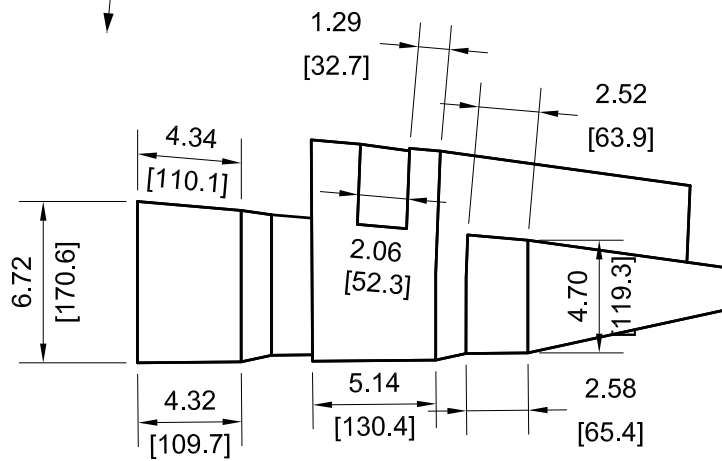
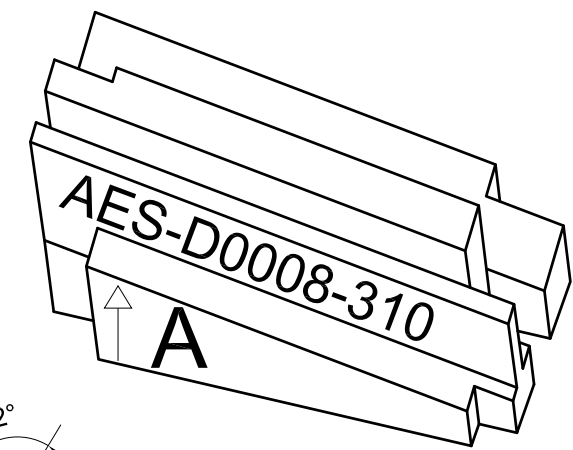

REAR VIEW RELATIVE TO VIEW D4-157

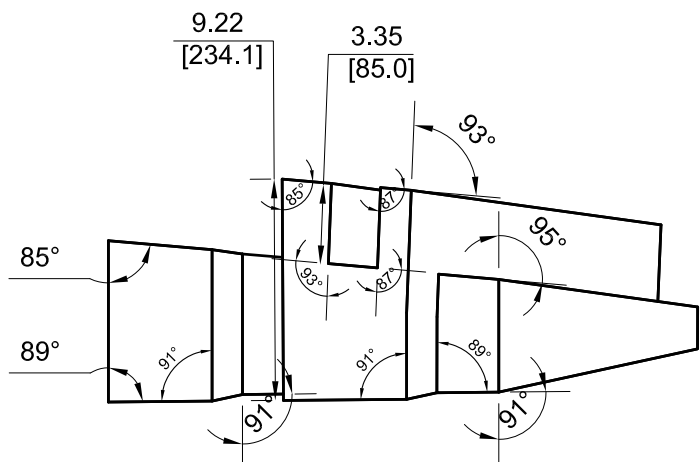

VIEW D4-157 REPEATED FOR CLARITY PURPOSES.



DRAWING NUMBER				
AES-D0008				
SIZE	SCALE	SHEET	OF	REVISION
A3	NONE	157	190	B

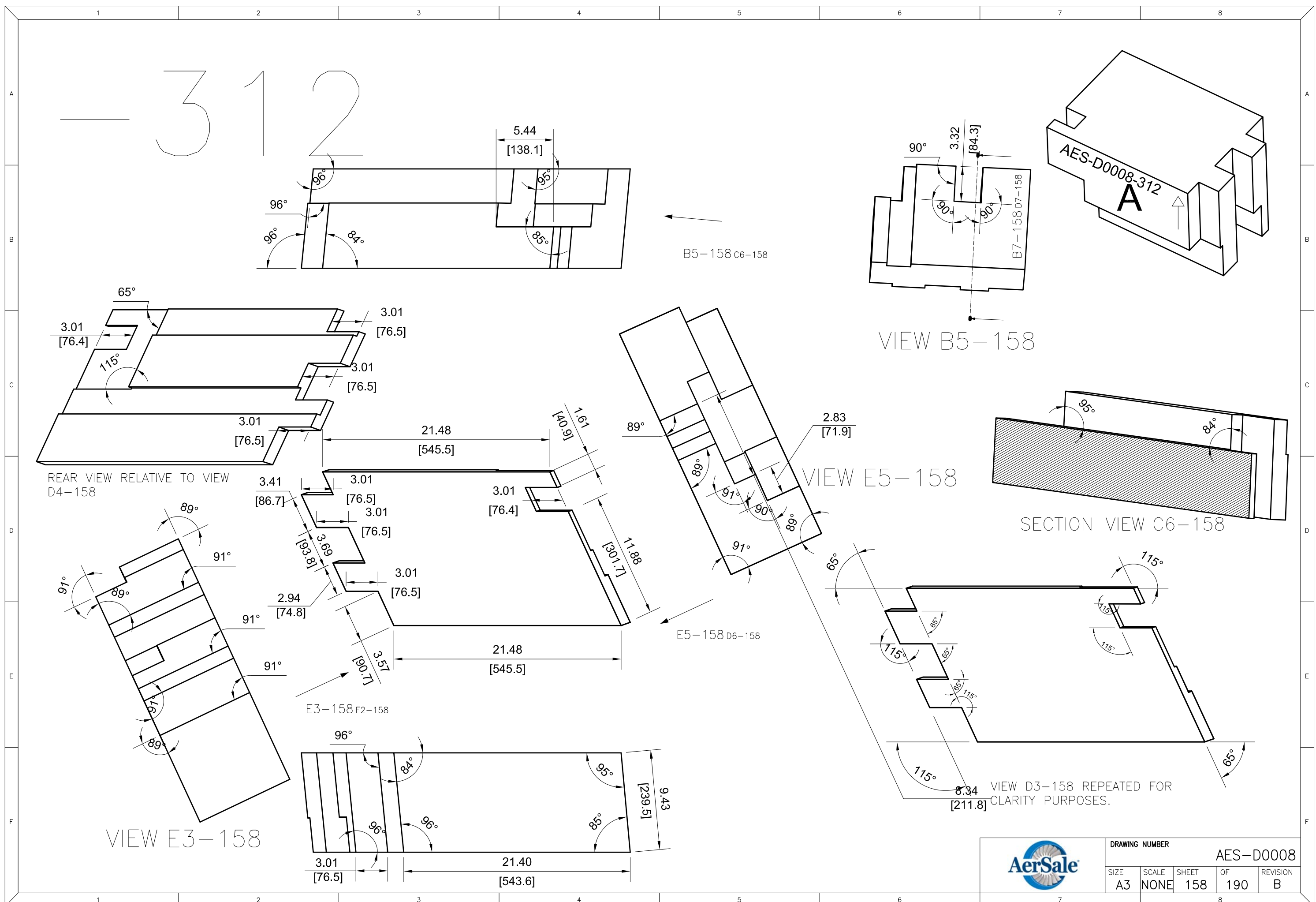

	DRAWING NUMBER				
	AES-D0008				
SIZE	SCALE	SHEET	OF	REVISION	
A3	NONE	158	190	B	

314

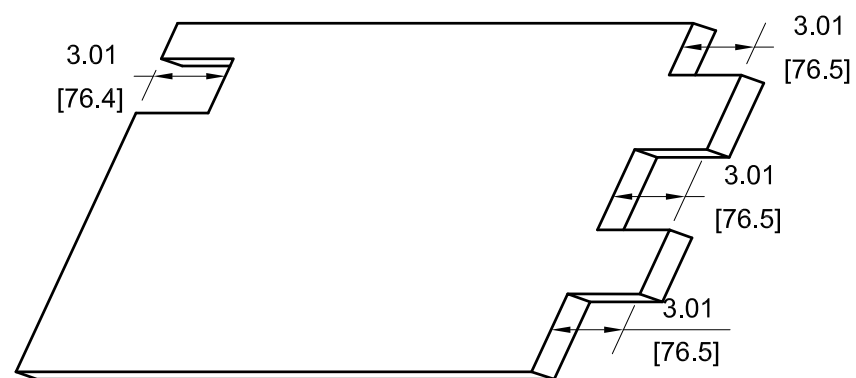

REAR VIEW RELATIVE TO VIEW D4-159

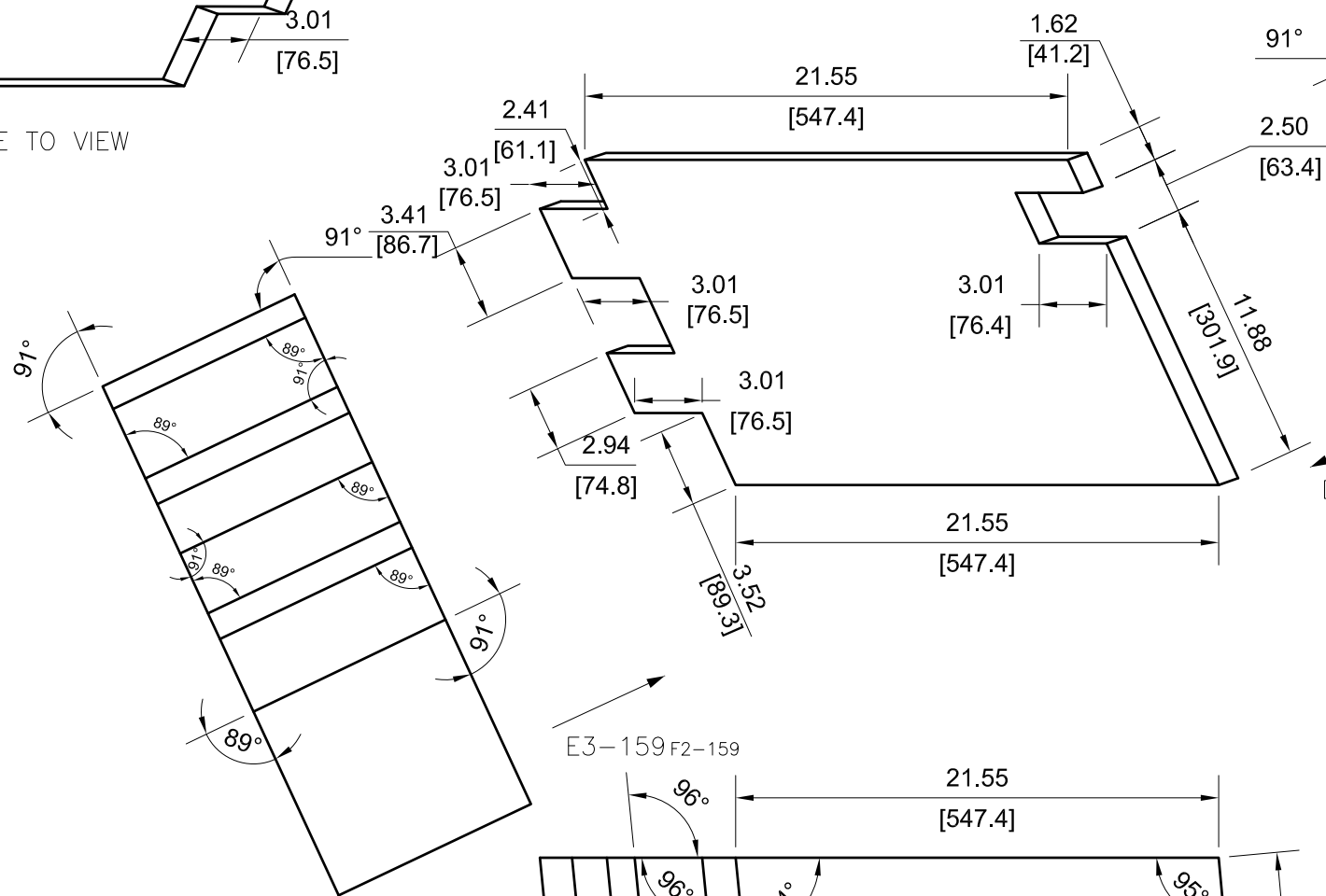
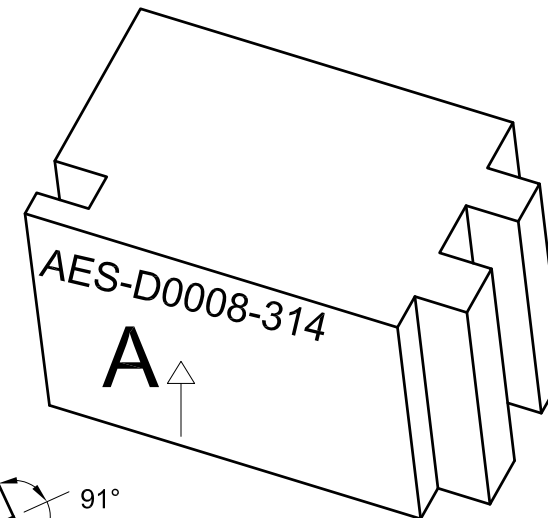
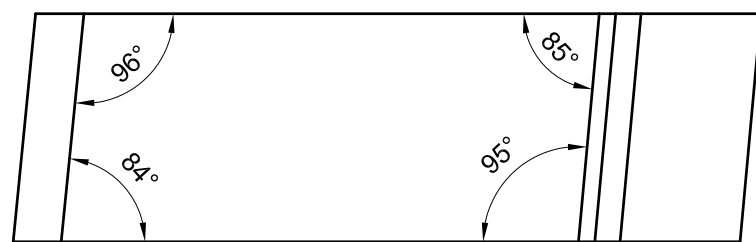

VIEW E3-159

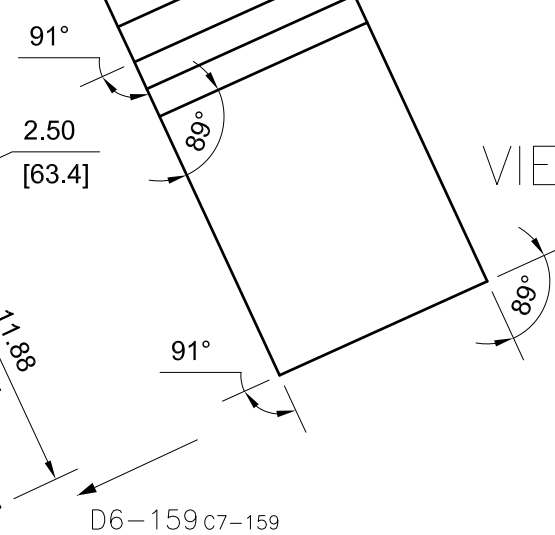
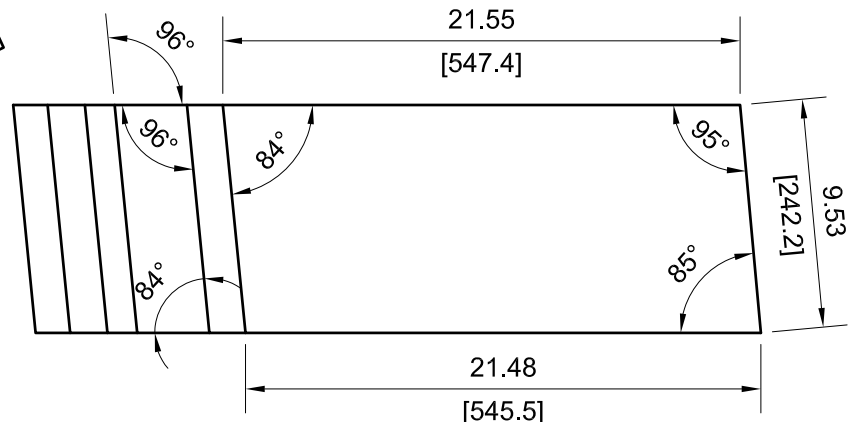

VIEW D6-159

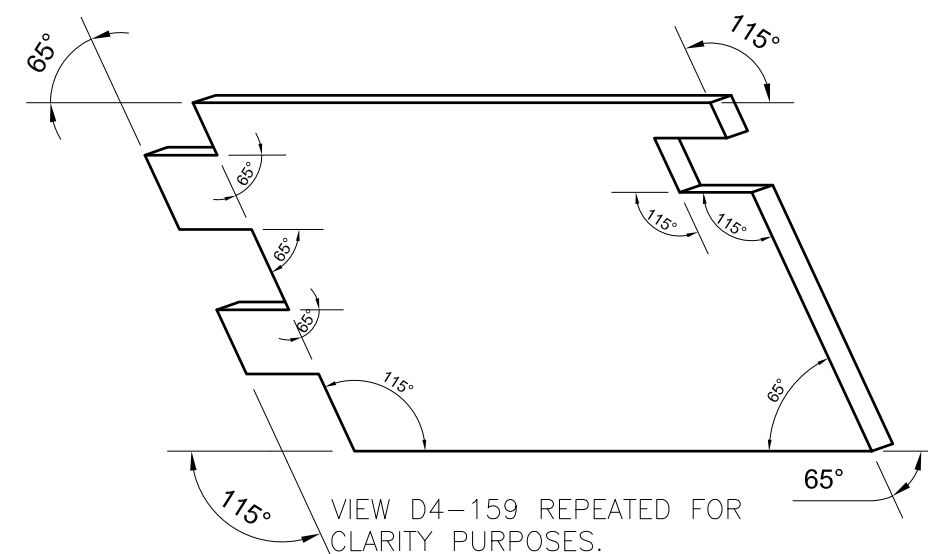

VIEW D4-159 REPEATED FOR CLARITY PURPOSES.



DRAWING NUMBER				
AES-D0008				
SIZE	SCALE	SHEET	OF	REVISION
A3	NONE	159	190	B

316

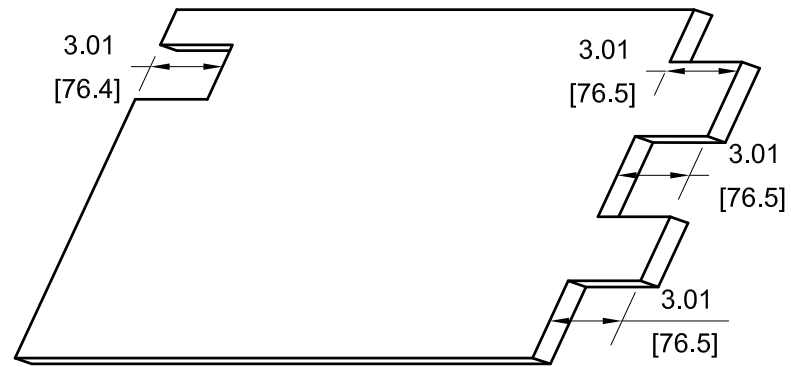

REAR VIEW RELATIVE TO VIEW D4-160

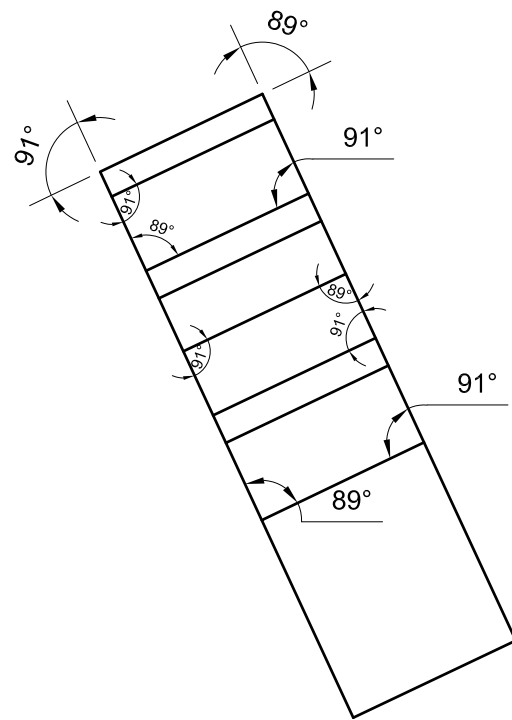
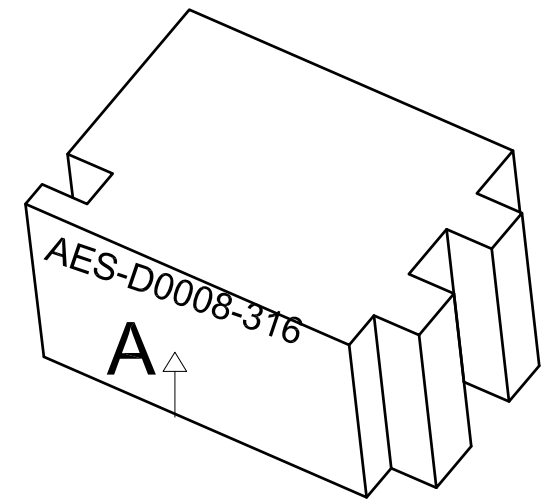
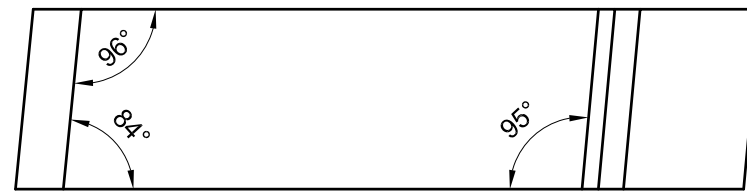

VIEW E3-160

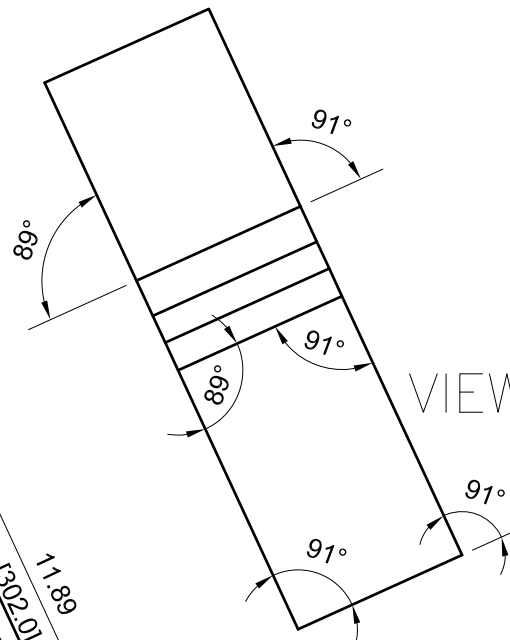
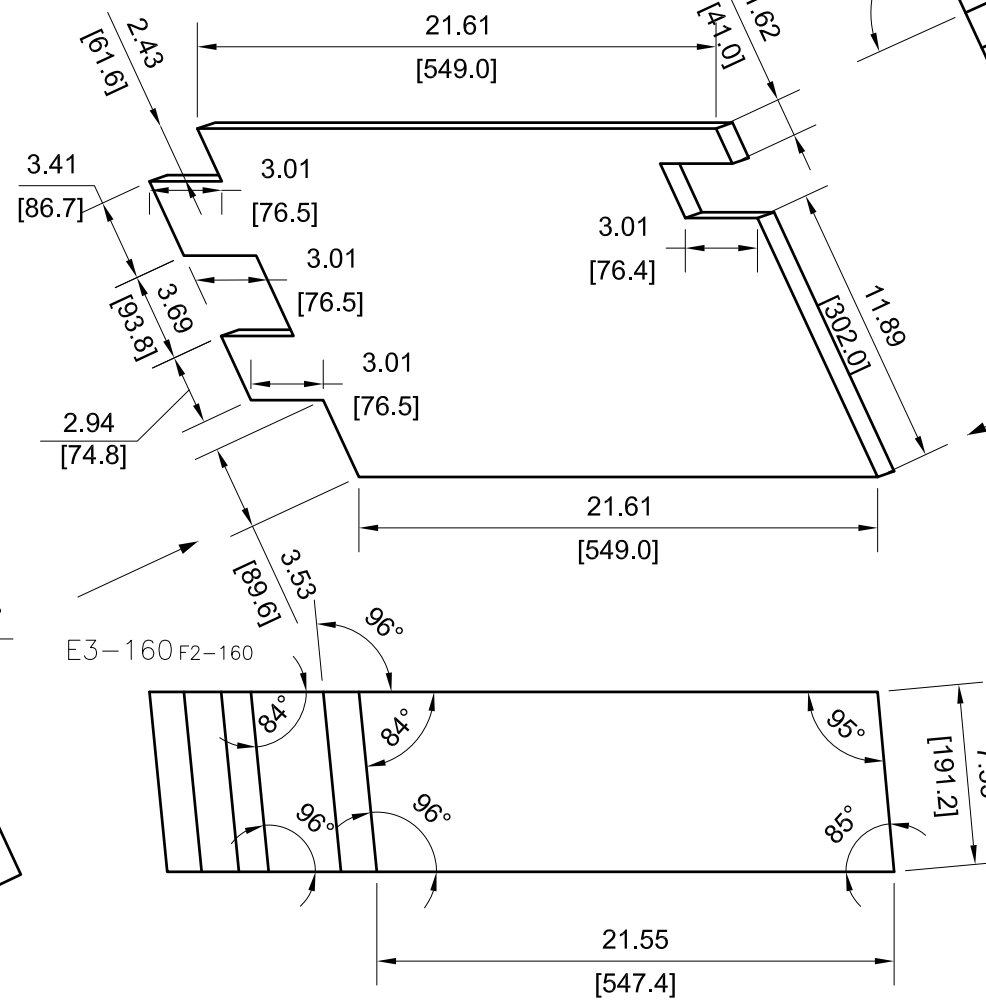

VIEW D6-160

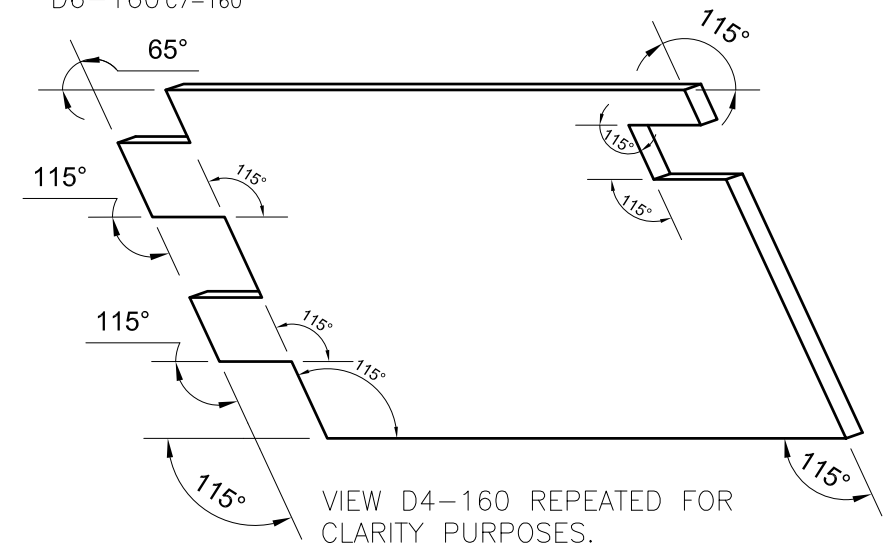

VIEW D4-160 REPEATED FOR CLARITY PURPOSES.



DRAWING NUMBER				
AES-D0008				
SIZE	SCALE	SHEET	OF	REVISION
A3	NONE	160	190	B

— 318

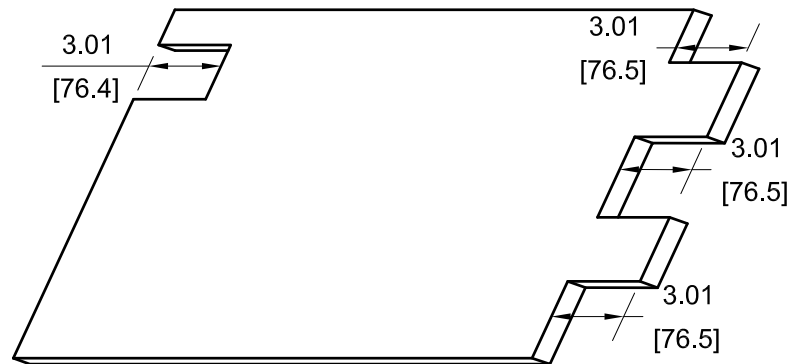

REAR VIEW RELATIVE TO VIEW D4-161

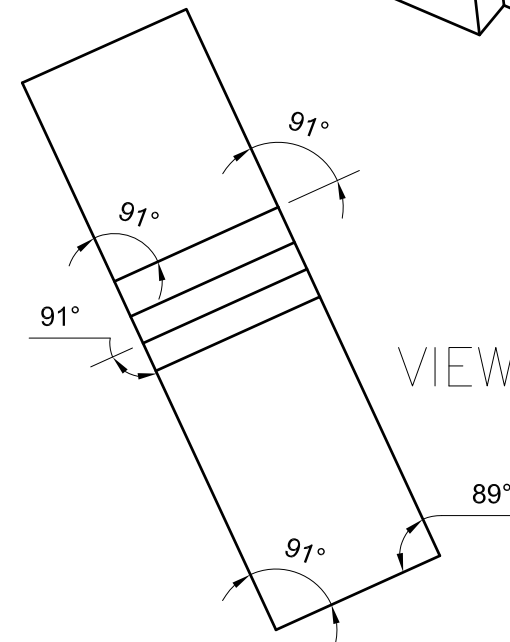
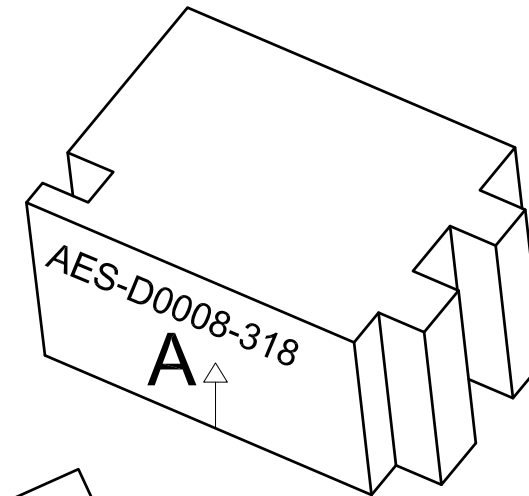
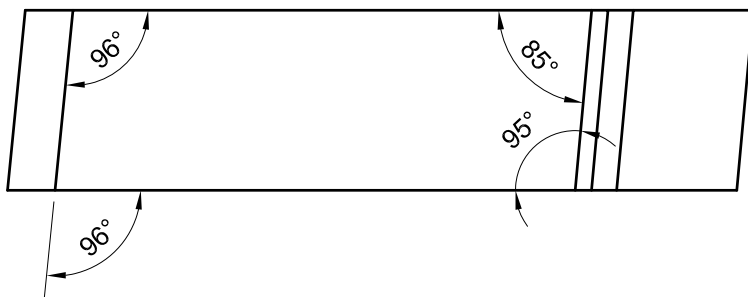

VIEW D6-161

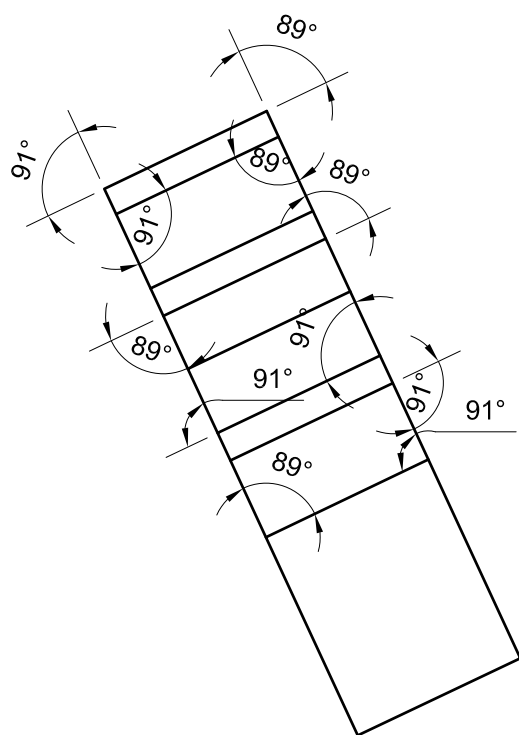

VIEW E3-161

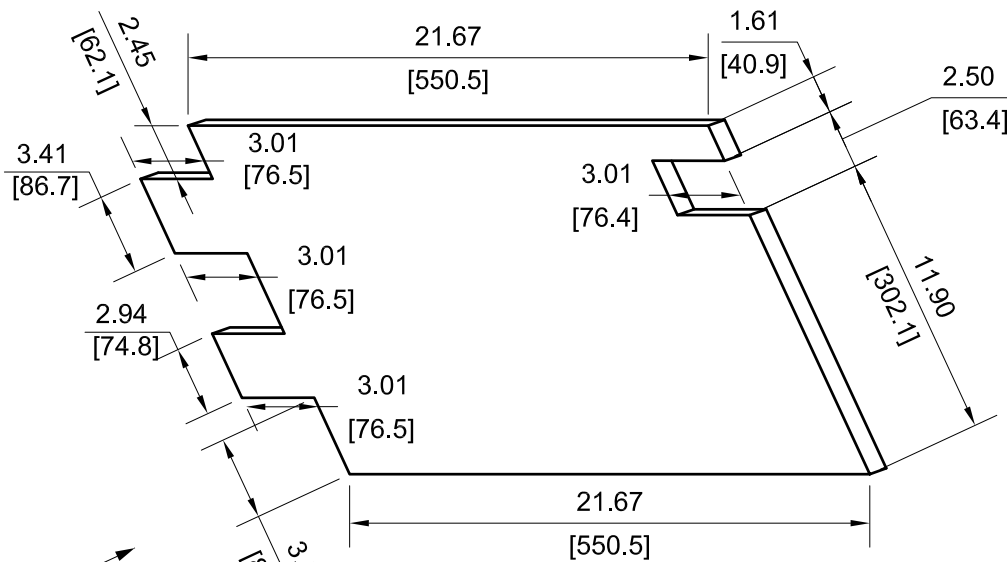

E3-161F2-161

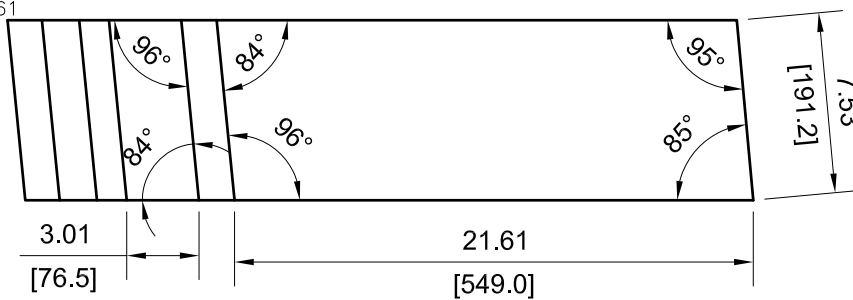

D6-161C7-161

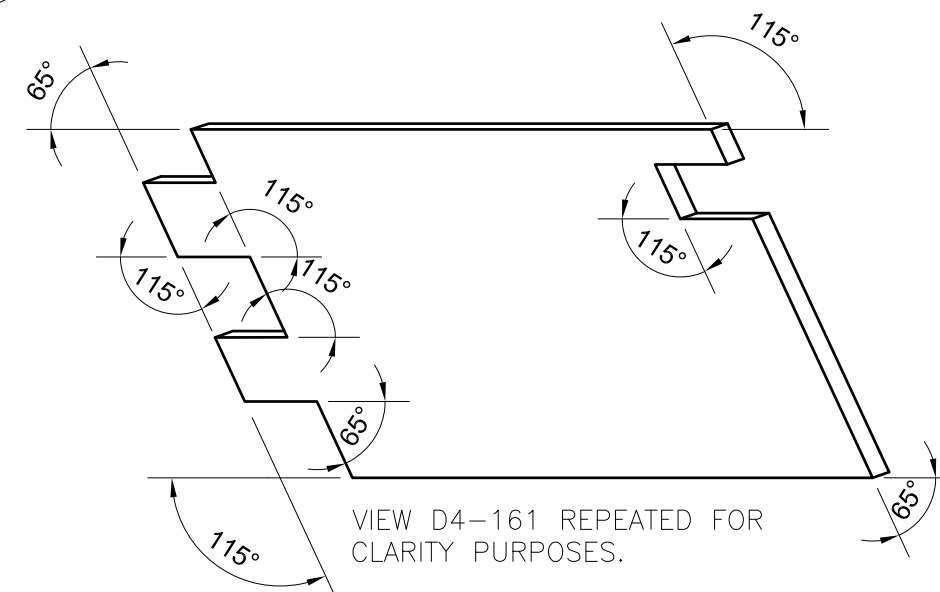

VIEW D4-161 REPEATED FOR CLARITY PURPOSES.



DRAWING NUMBER				
AES-D0008				
SIZE	SCALE	SHEET	OF	REVISION
A3	NONE	161	190	B

320

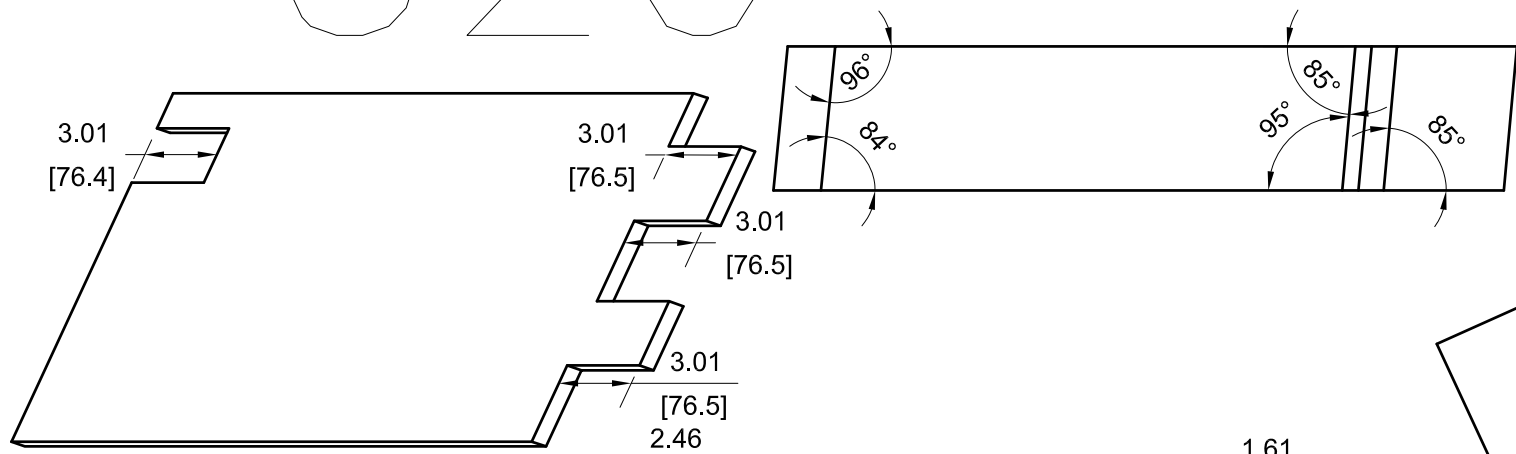

REAR VIEW RELATIVE TO VIEW D4-162

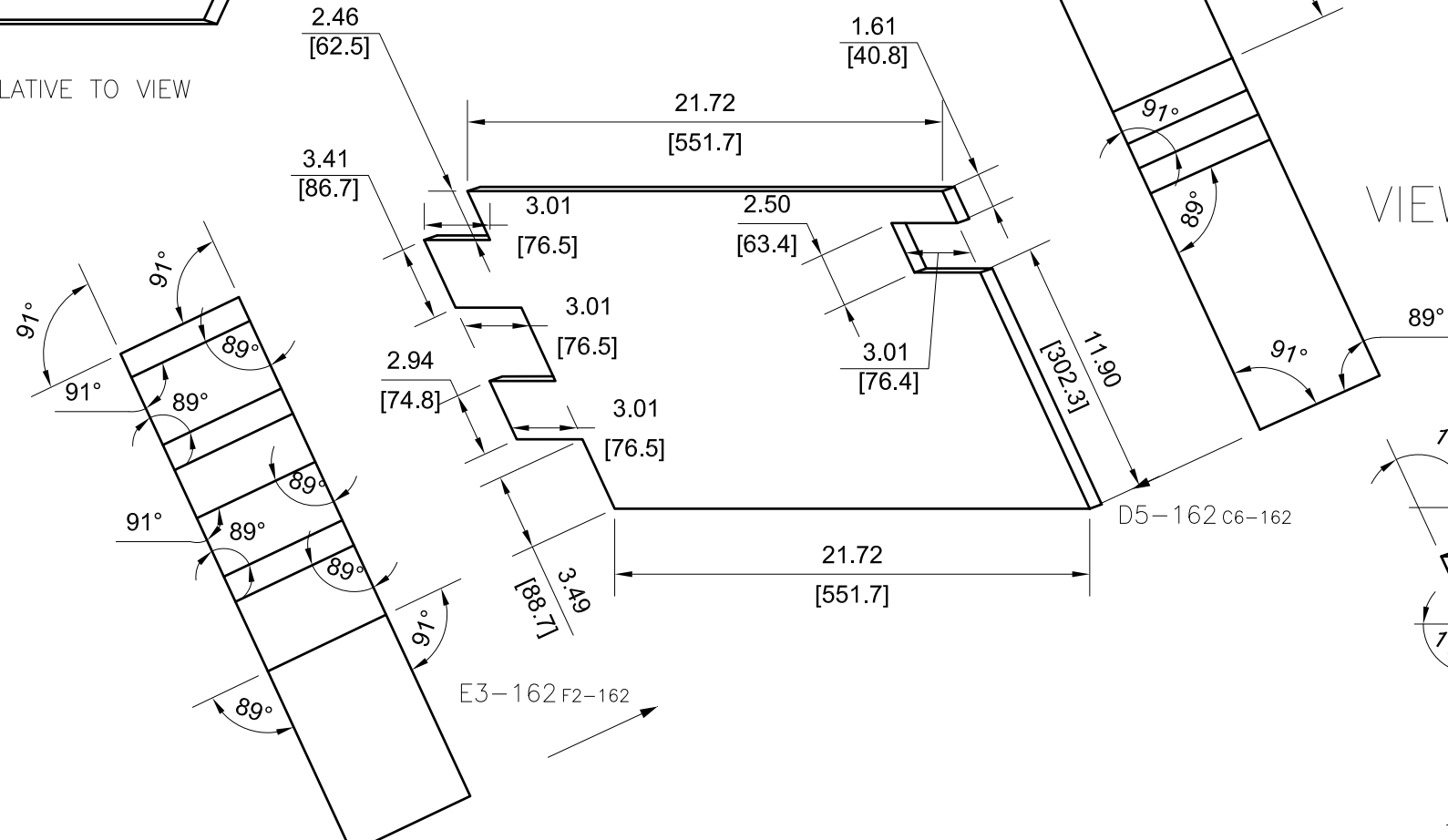
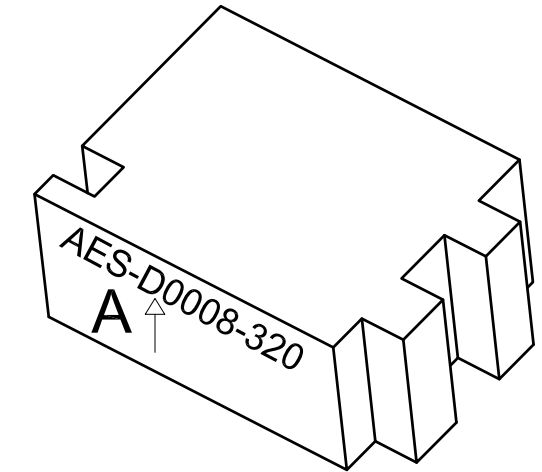

VIEW D5-162

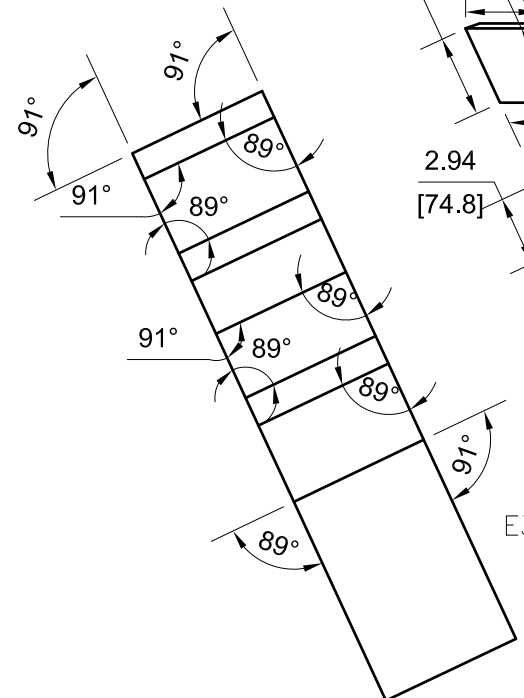

VIEW E3-162

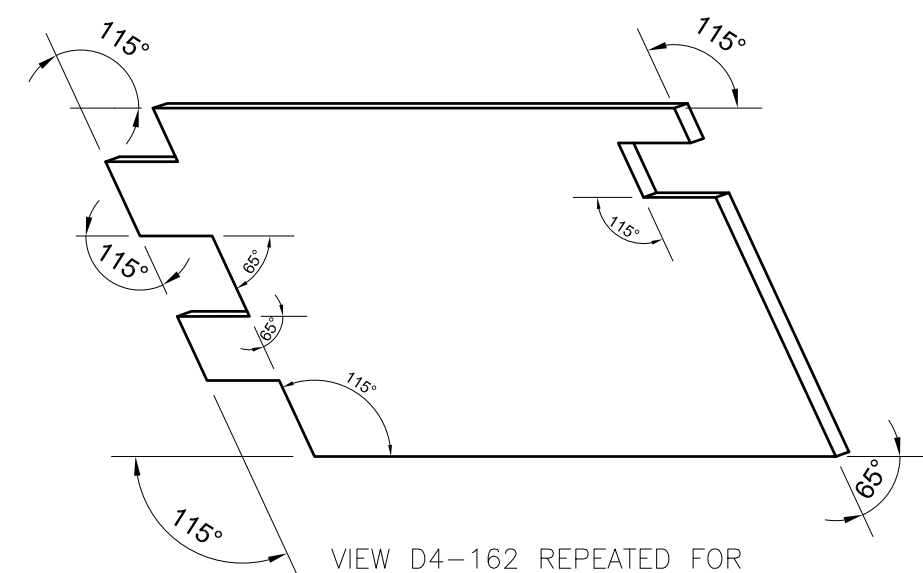
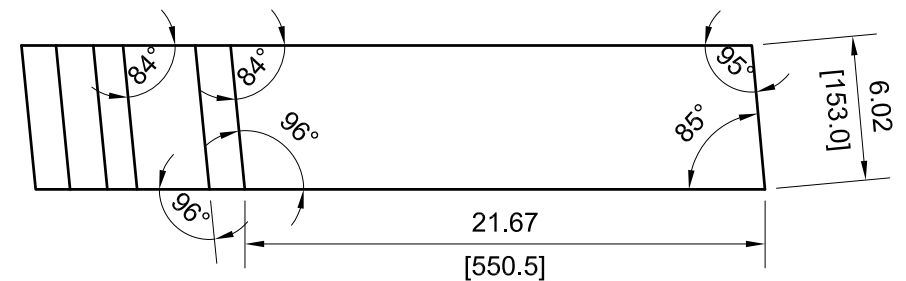

VIEW D4-162 REPEATED FOR CLARITY PURPOSES.



DRAWING NUMBER					AES-D0008	
SIZE	SCALE	SHEET	OF	REVISION		
A3	NONE	162	190	B		

322

SECTION VIEW C5-163

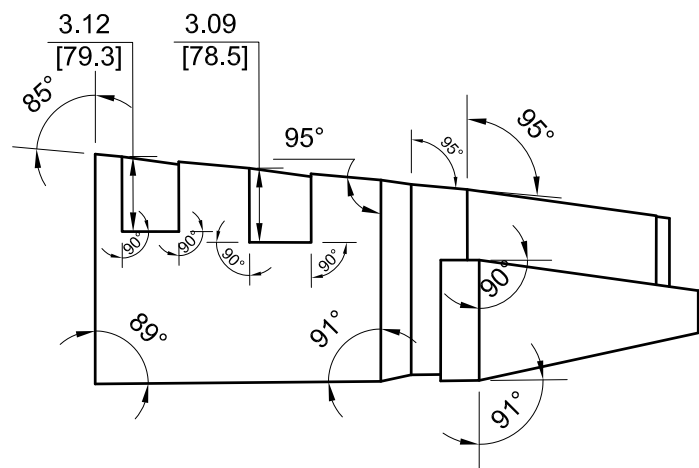

VIEW D5-163 REPEATED FOR CLARITY PURPOSES.

VIEW A5-163

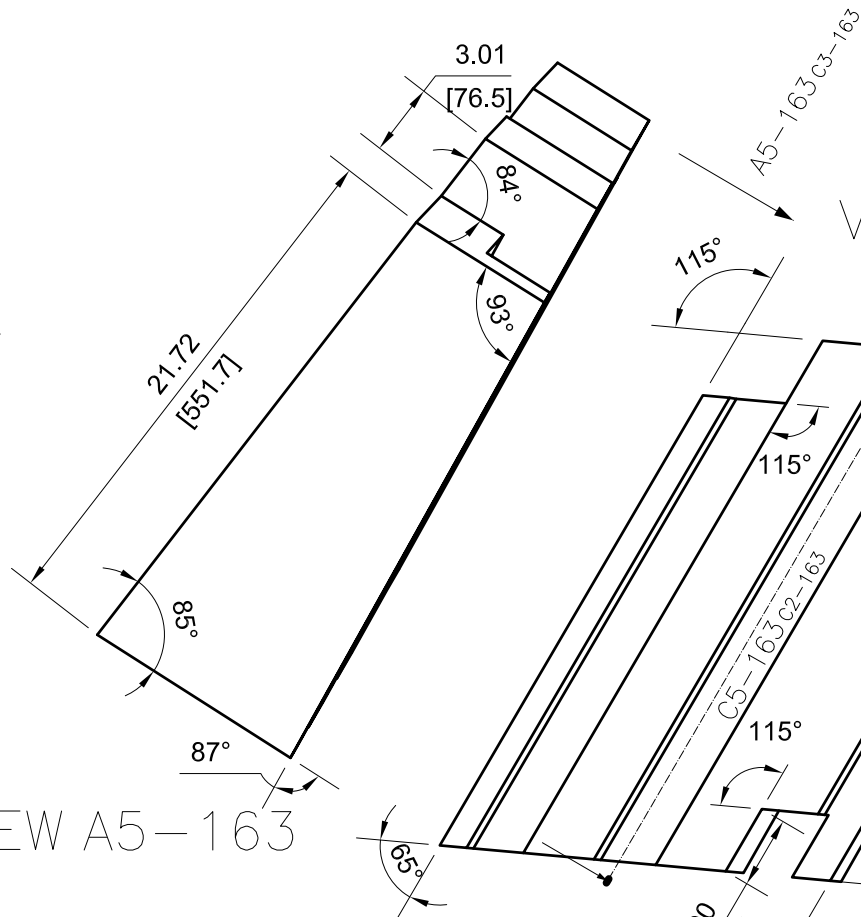

VIEW B3-163

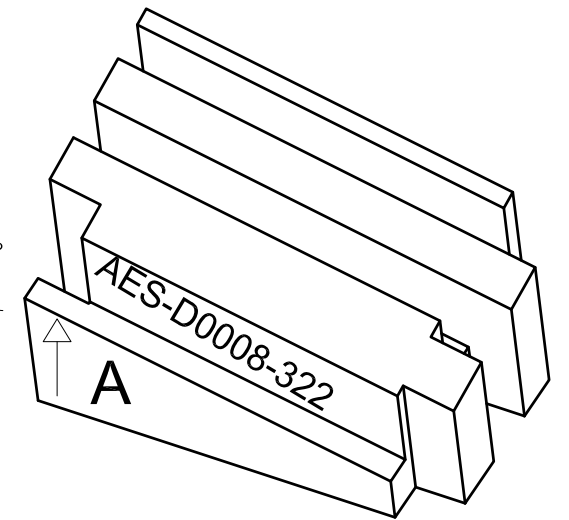
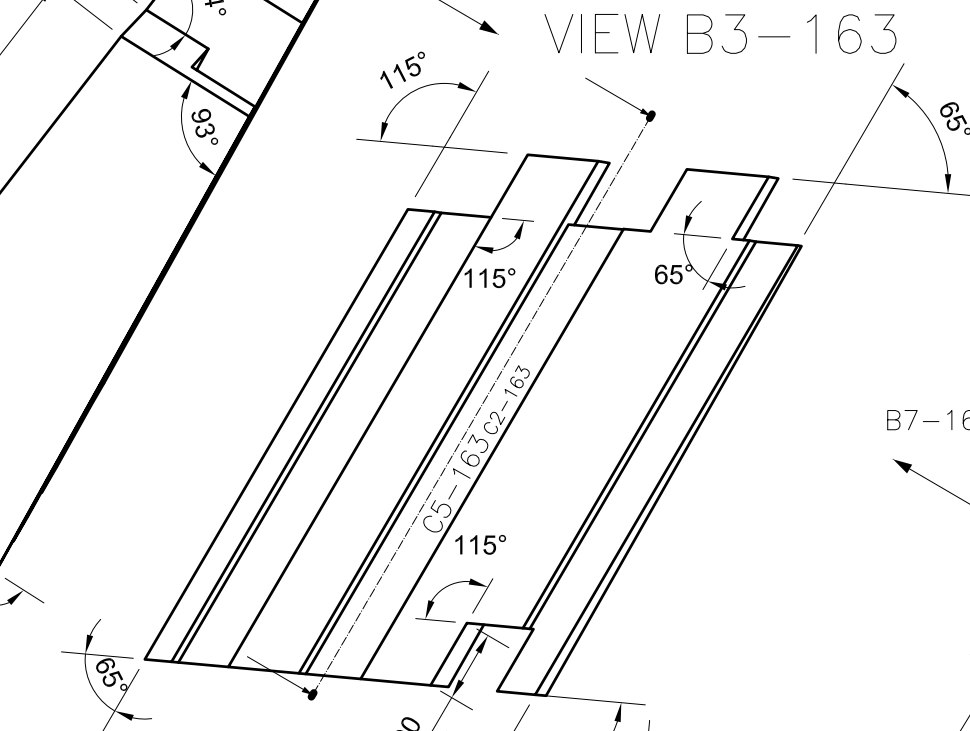

B7-163 E7-163

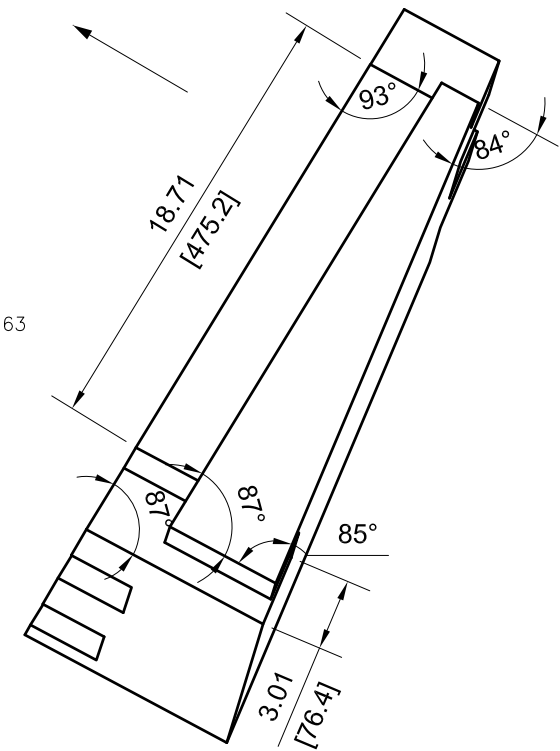

VIEW B7-163

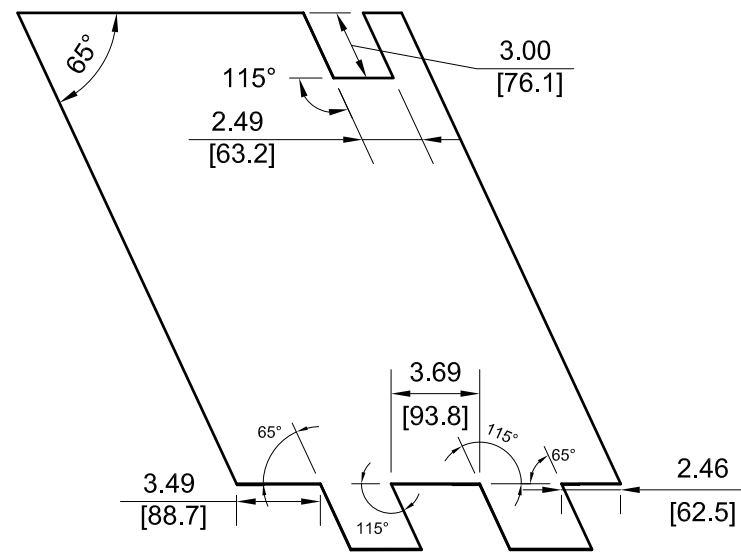
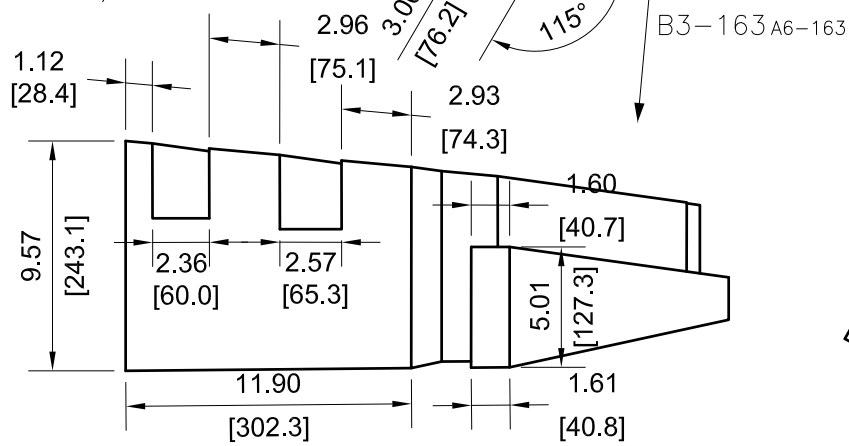

DRAWING NUMBER				
AES-D0008				
SIZE	SCALE	SHEET	OF	REVISION
A3	NONE	163	190	B

324

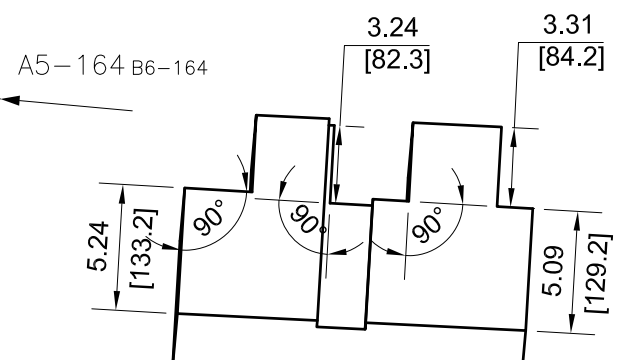
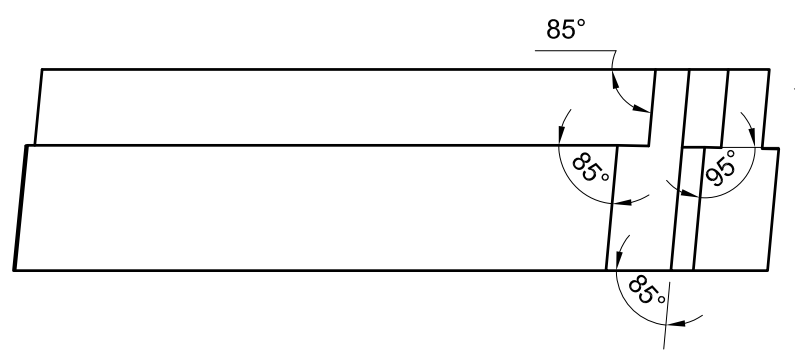
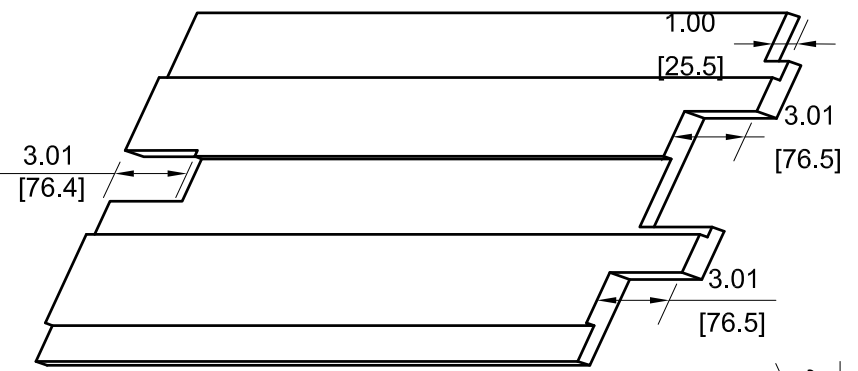

VIEW A5-164

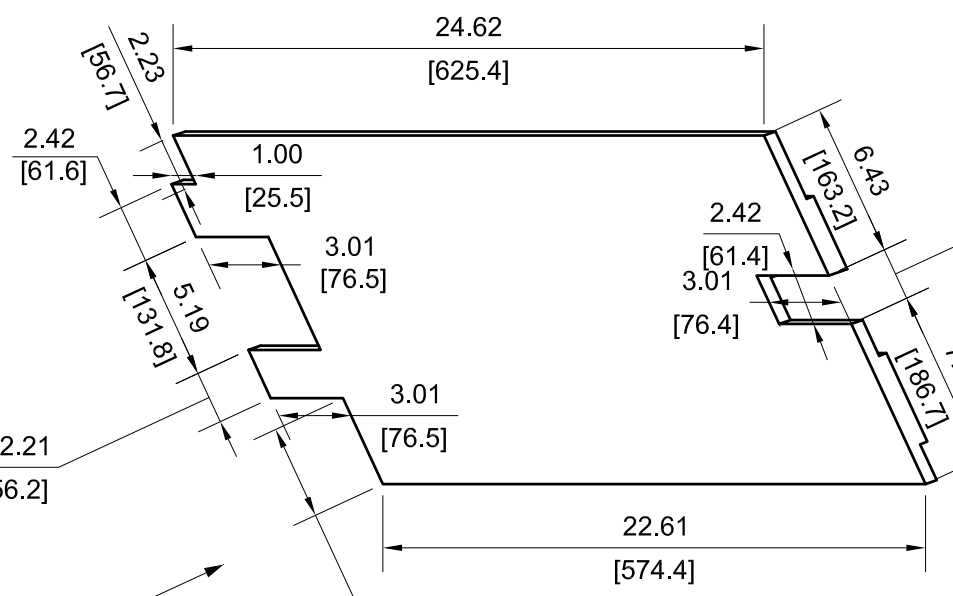
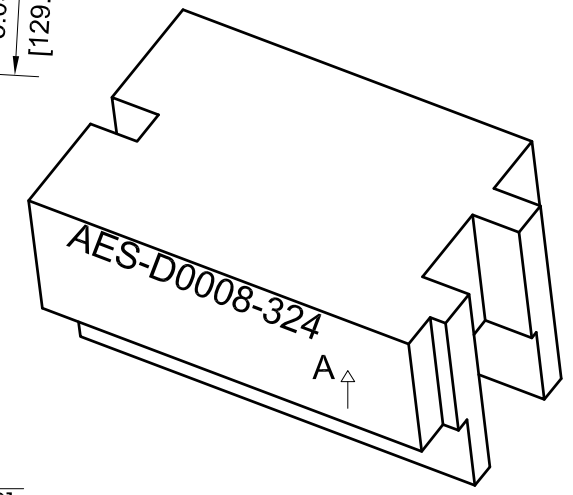

VIEW D5-164

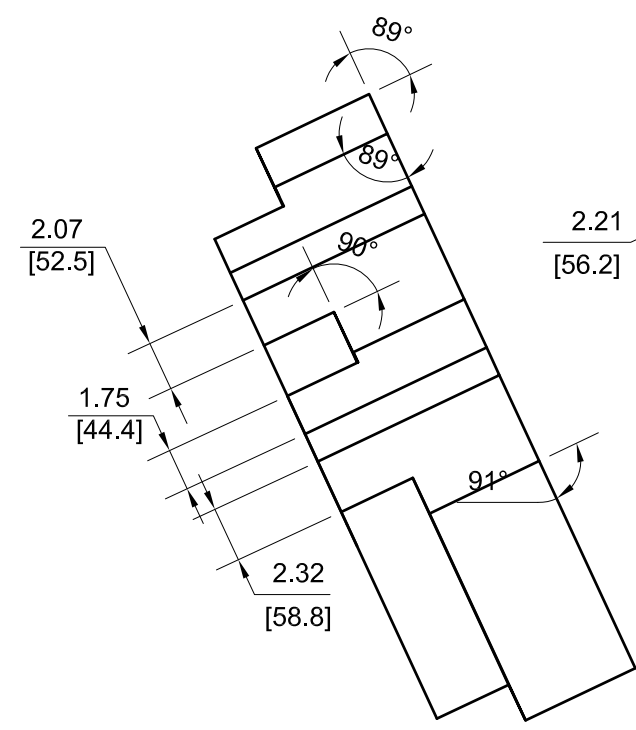

VIEW E3-164

E3-164 F2-164

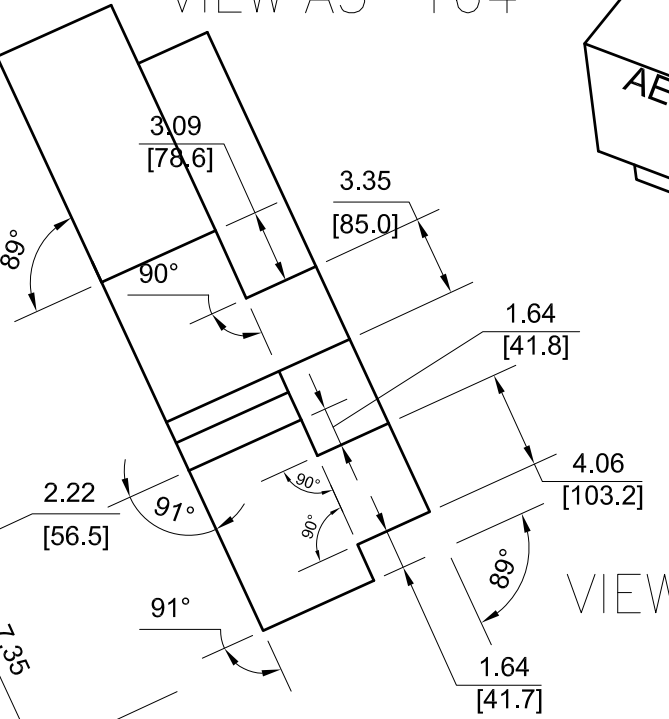

VIEW D4-164 REPEATED FOR CLARITY PURPOSES.

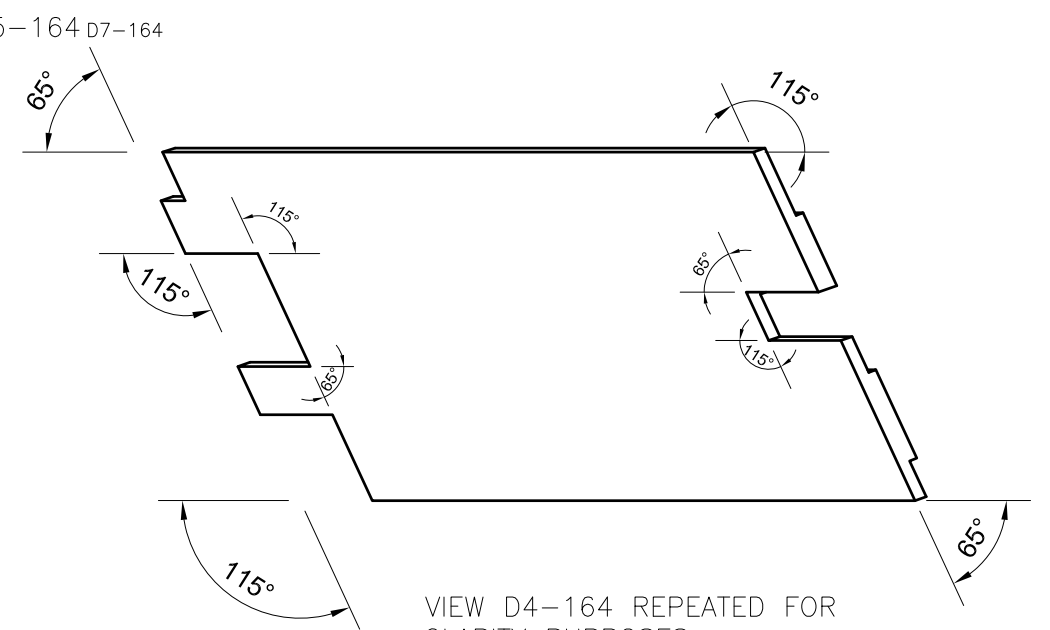
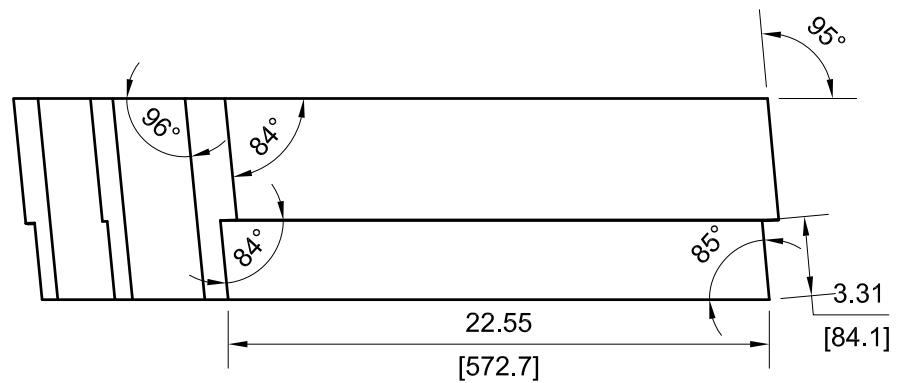

	DRAWING NUMBER				
	AES-D0008				
SIZE	SCALE	SHEET	OF	REVISION	
A3	NONE	164	190	B	

326

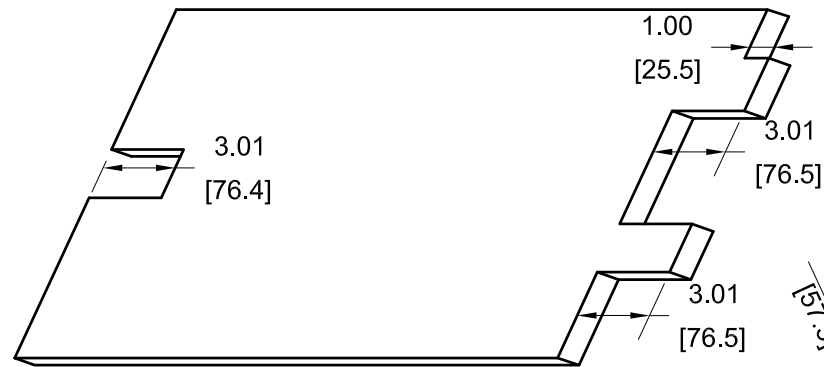

REAR VIEW RELATIVE TO VIEW D4-165

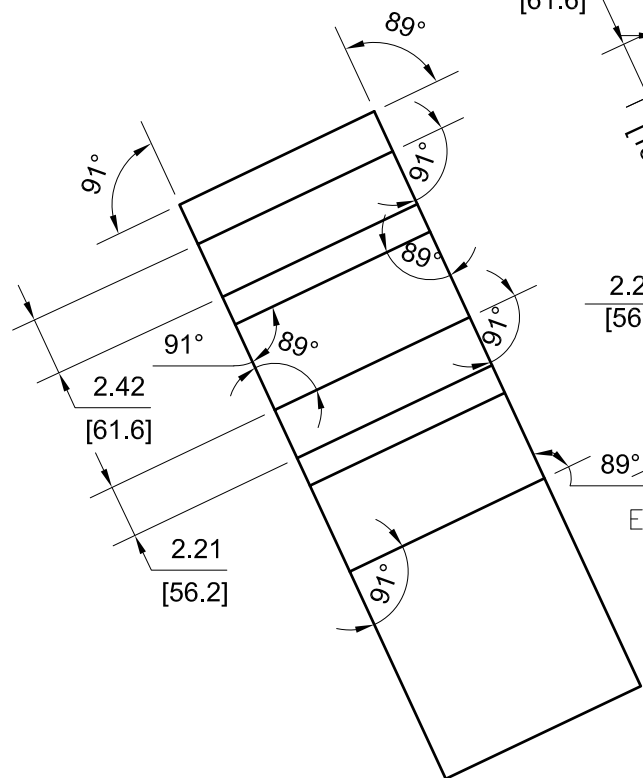
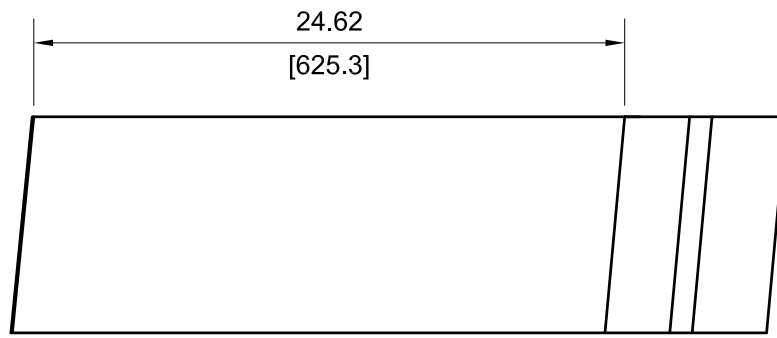

VIEW E3-165

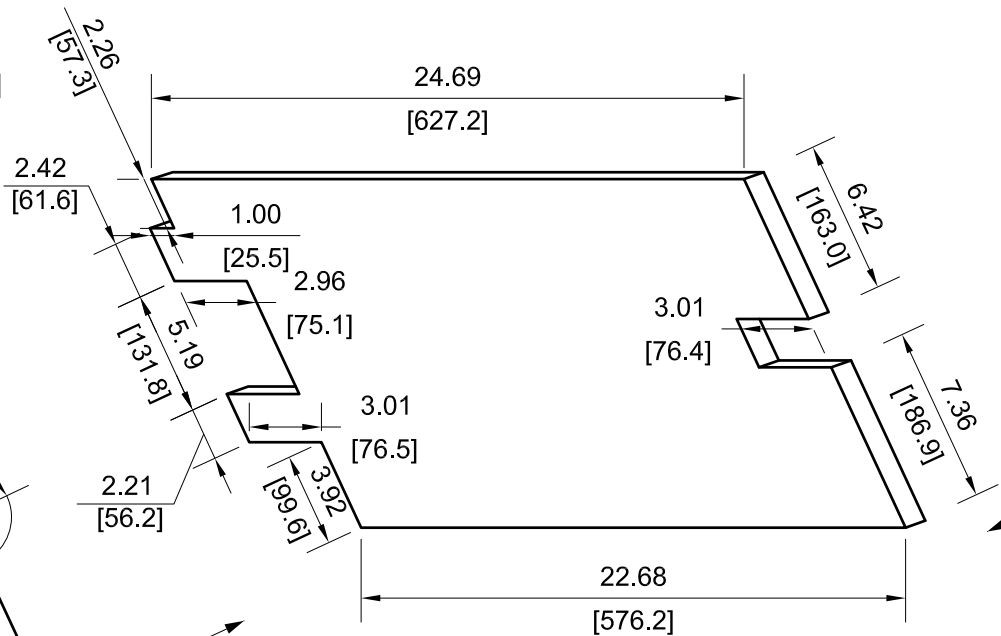

E3-165 F2-165

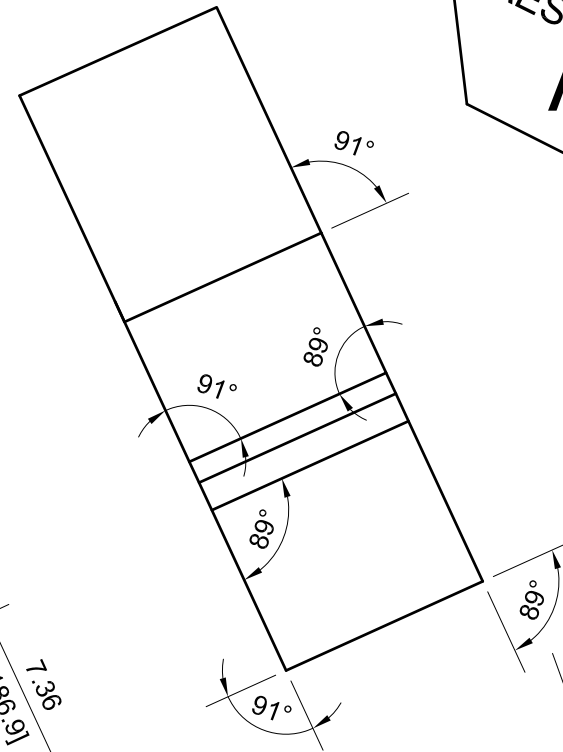
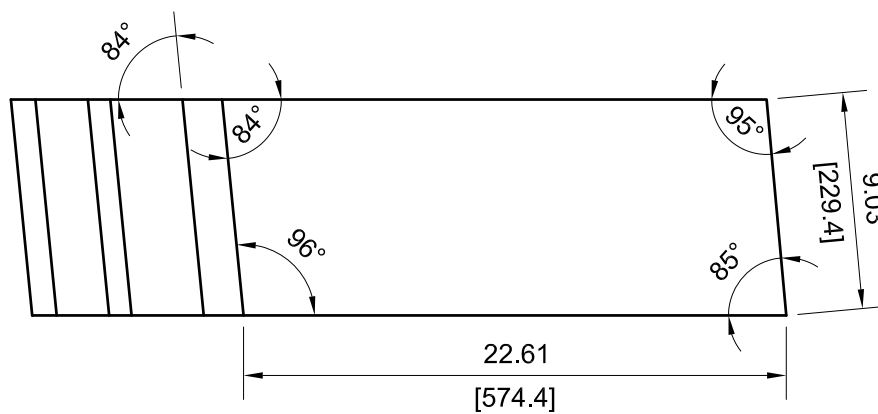

VIEW D6-165

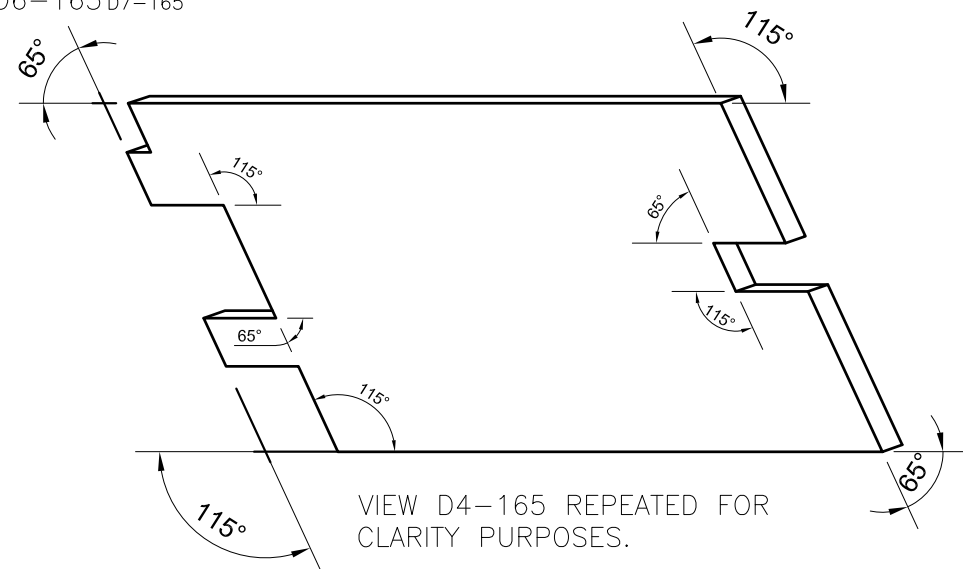

VIEW D4-165 REPEATED FOR CLARITY PURPOSES.

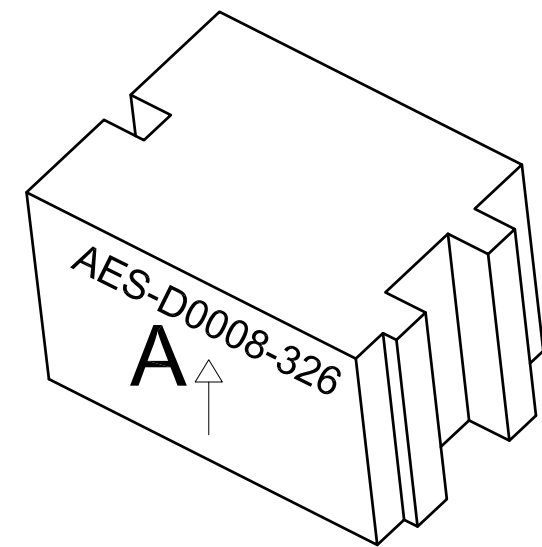

DRAWING NUMBER					AES-D0008	
SIZE	SCALE	SHEET	OF	REVISION		
A3	NONE	165	190	B		

328

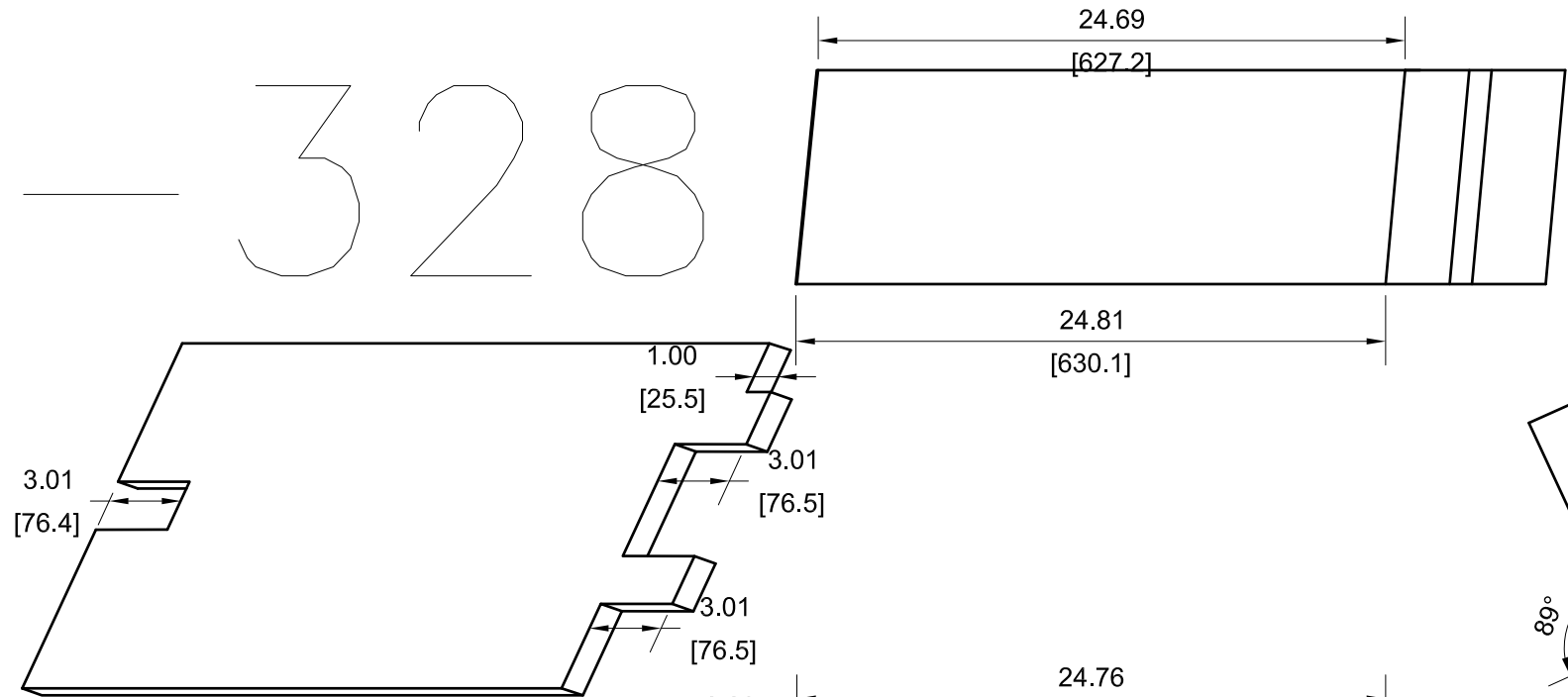

REAR VIEW RELATIVE TO VIEW C4-166

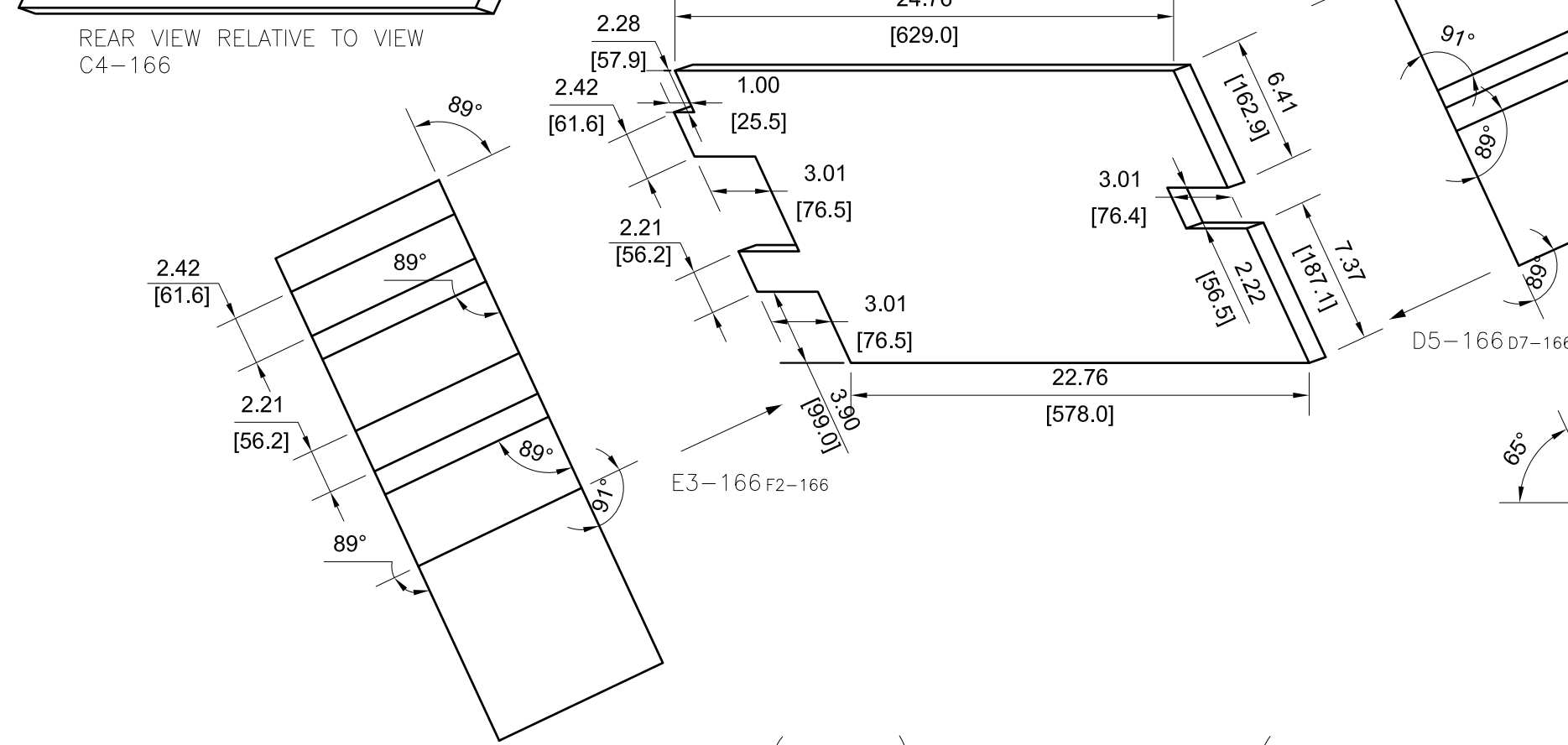
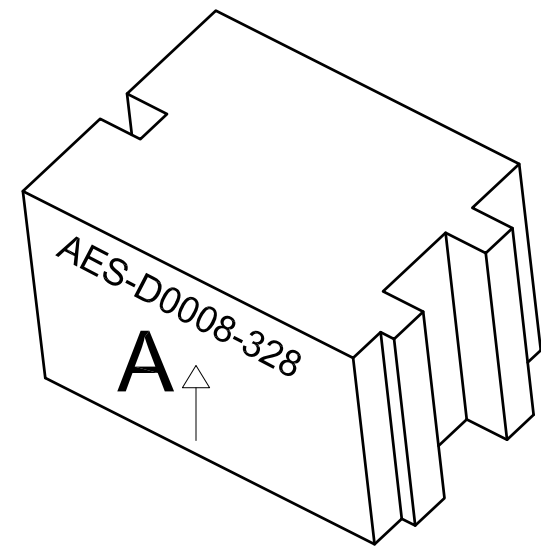

VIEW E3-166

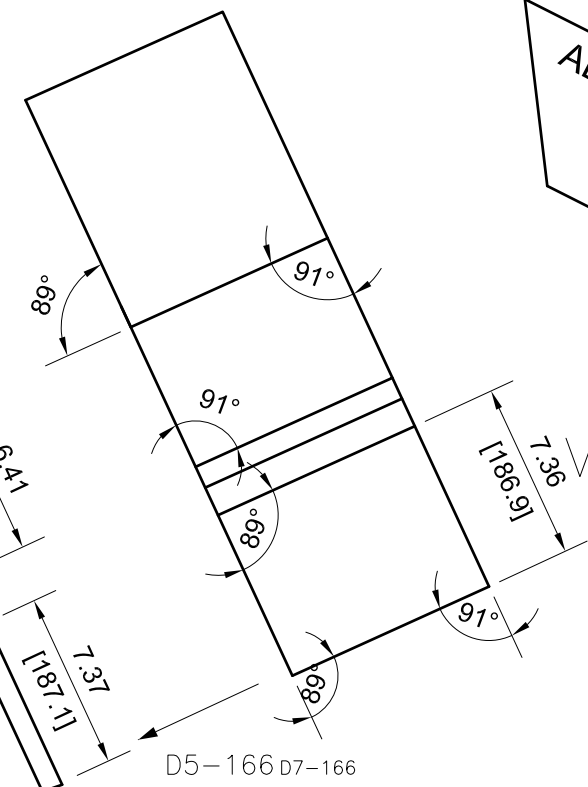
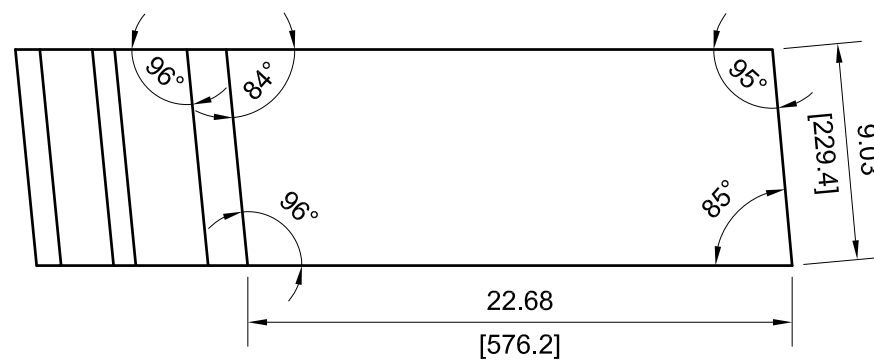

VIEW D5-166

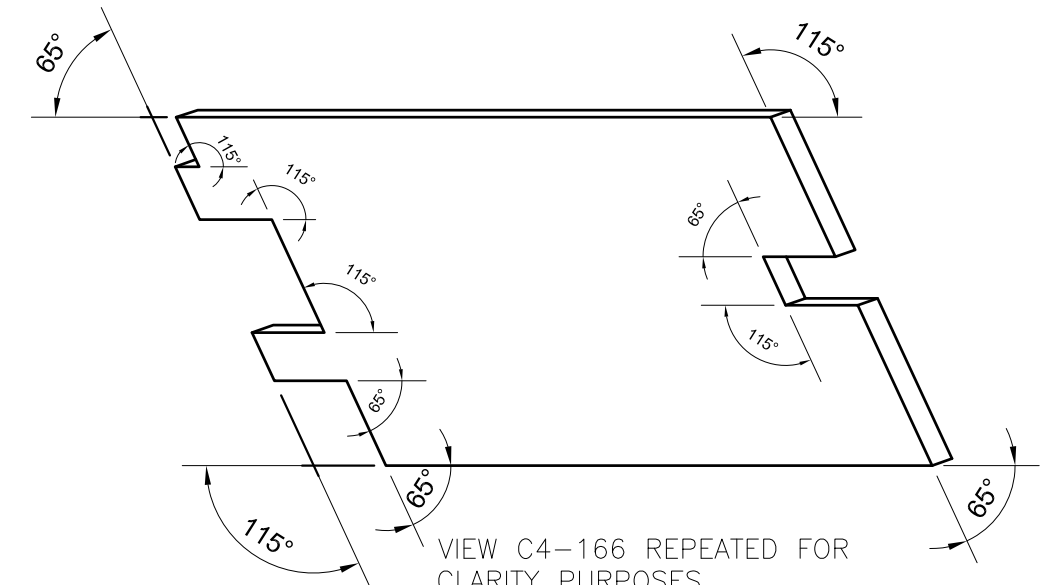

VIEW C4-166 REPEATED FOR CLARITY PURPOSES.



DRAWING NUMBER				
AES-D0008				
SIZE	SCALE	SHEET	OF	REVISION
A3	NONE	166	190	B

330

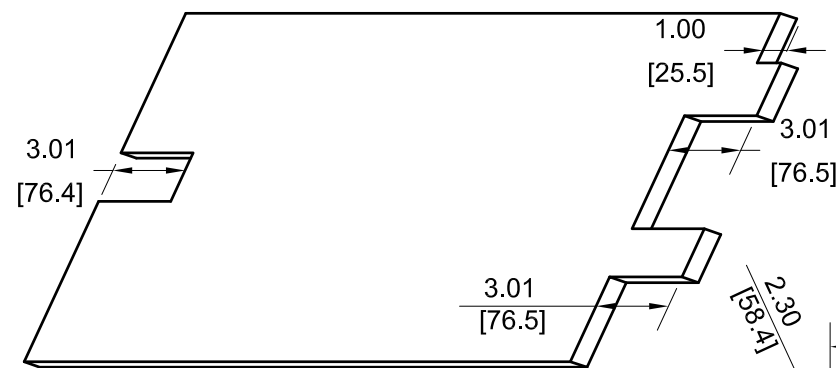
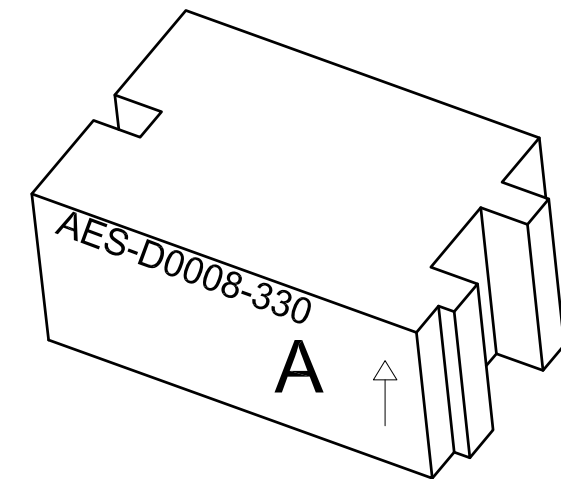
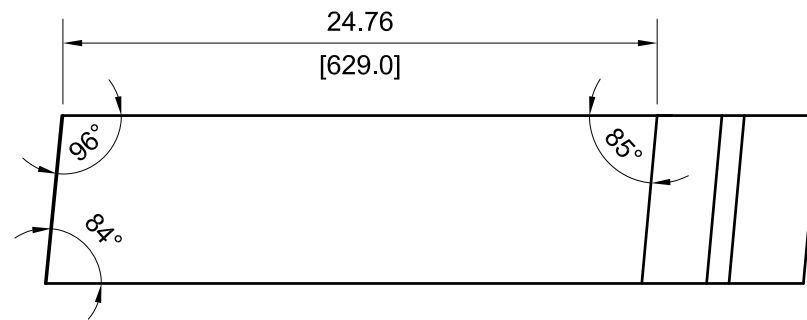

REAR VIEW RELATIVE TO VIEW D4-167

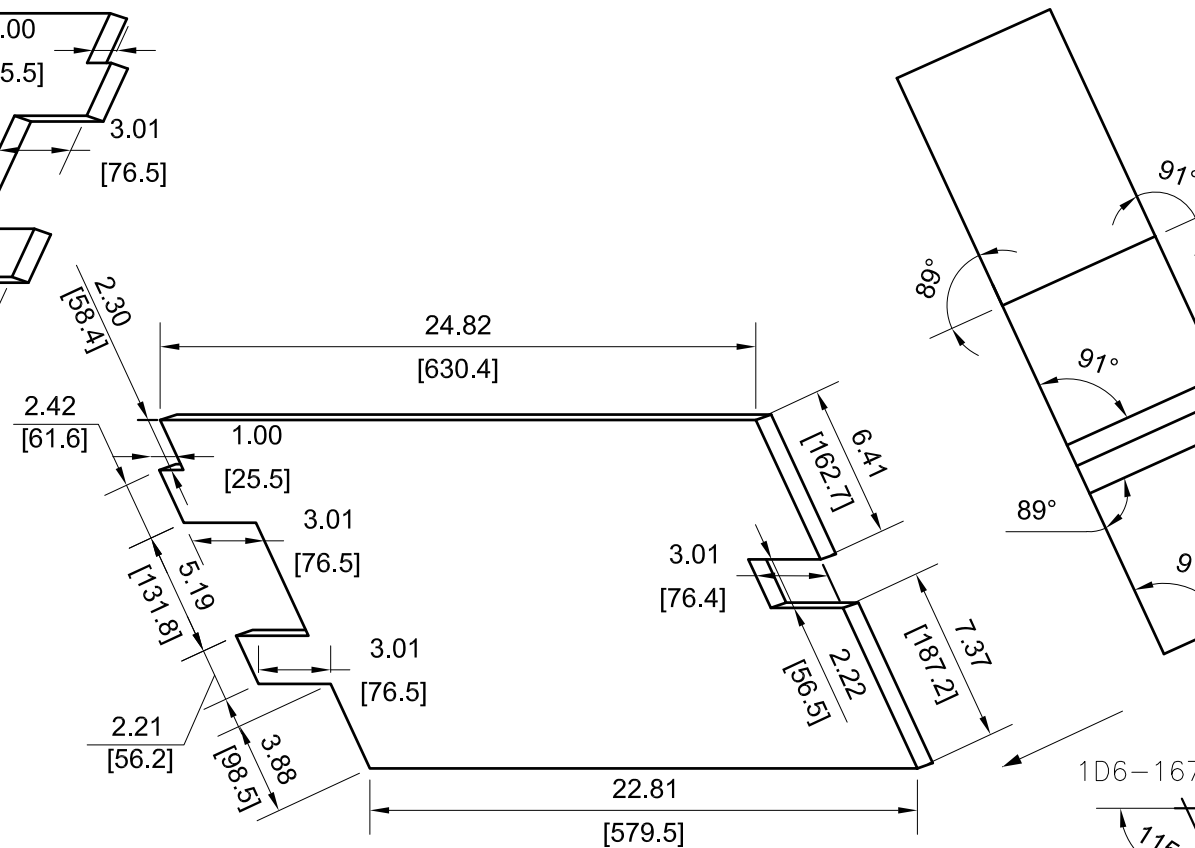

VIEW 1D6-167

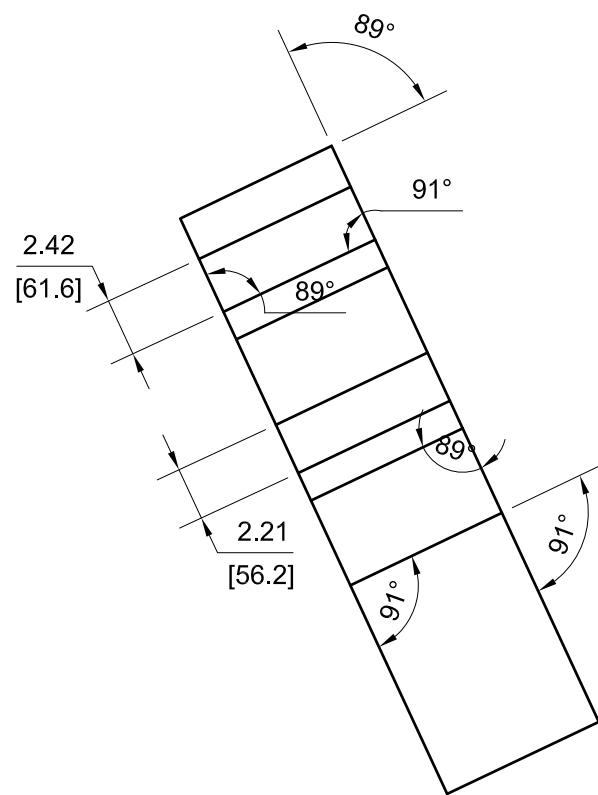

VIEW E3-167

E3-167 F2-167

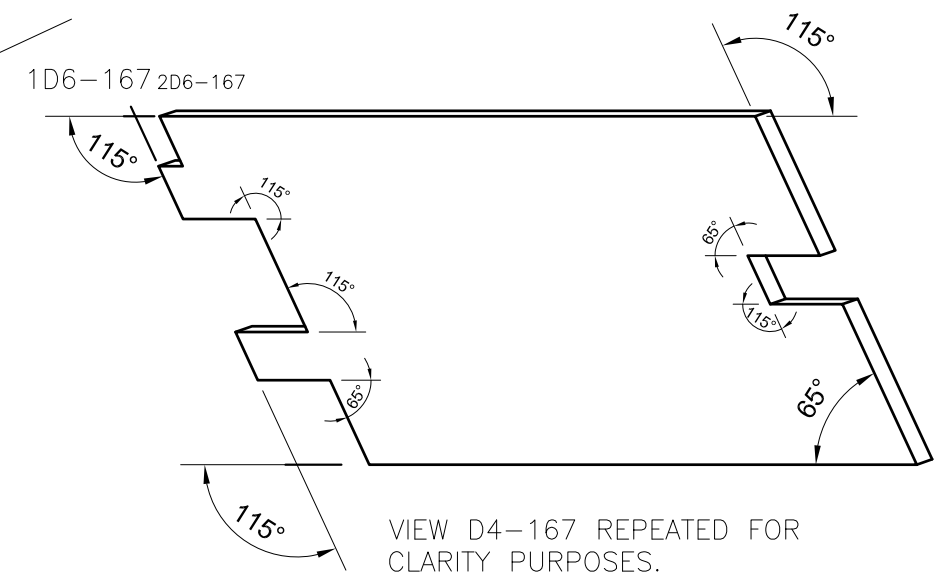
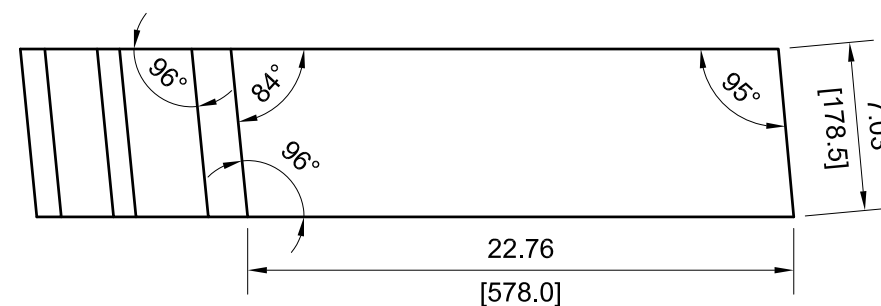

VIEW D4-167 REPEATED FOR CLARITY PURPOSES.



DRAWING NUMBER				
AES-D0008				
SIZE	SCALE	SHEET	OF	REVISION
A3	NONE	167	190	B

332

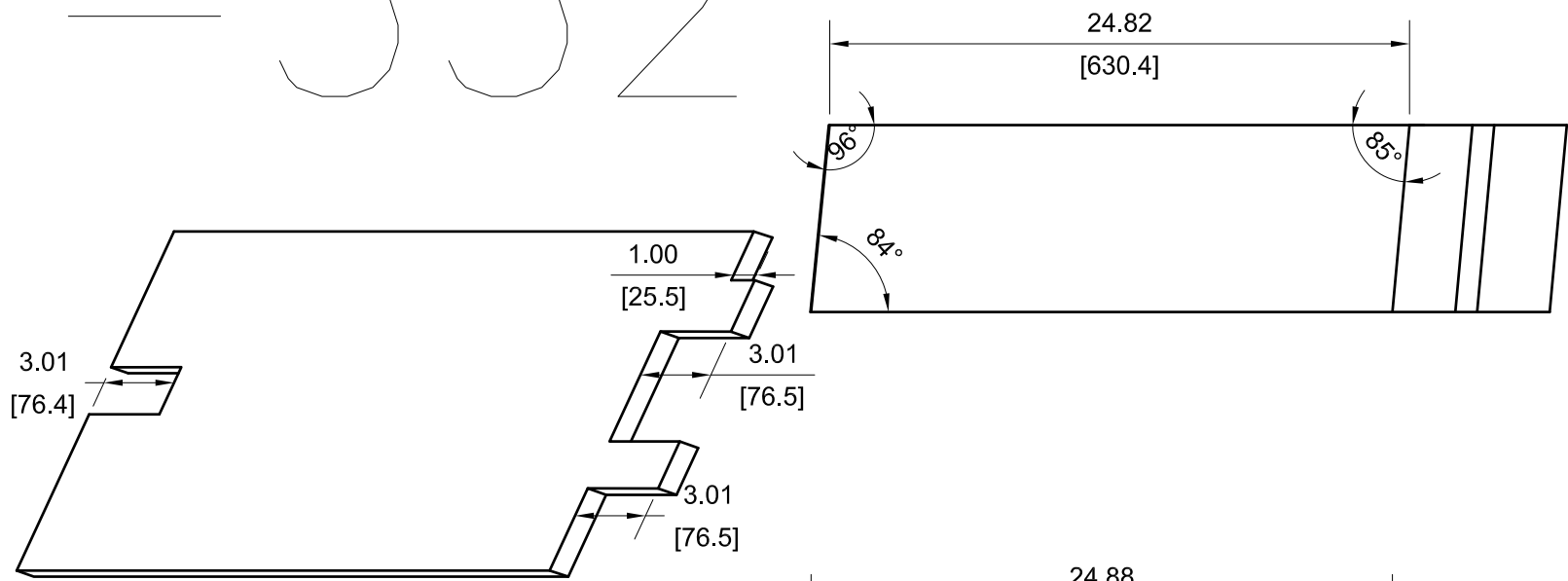
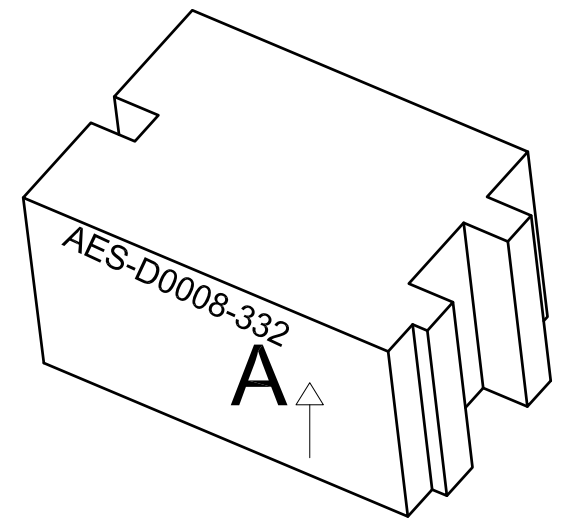

REAR VIEW RELATIVE TO VIEW D4-168

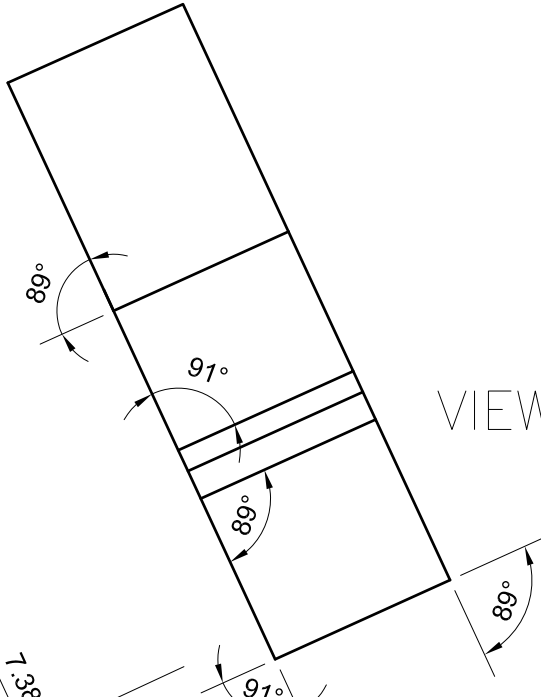

VIEW D5-168

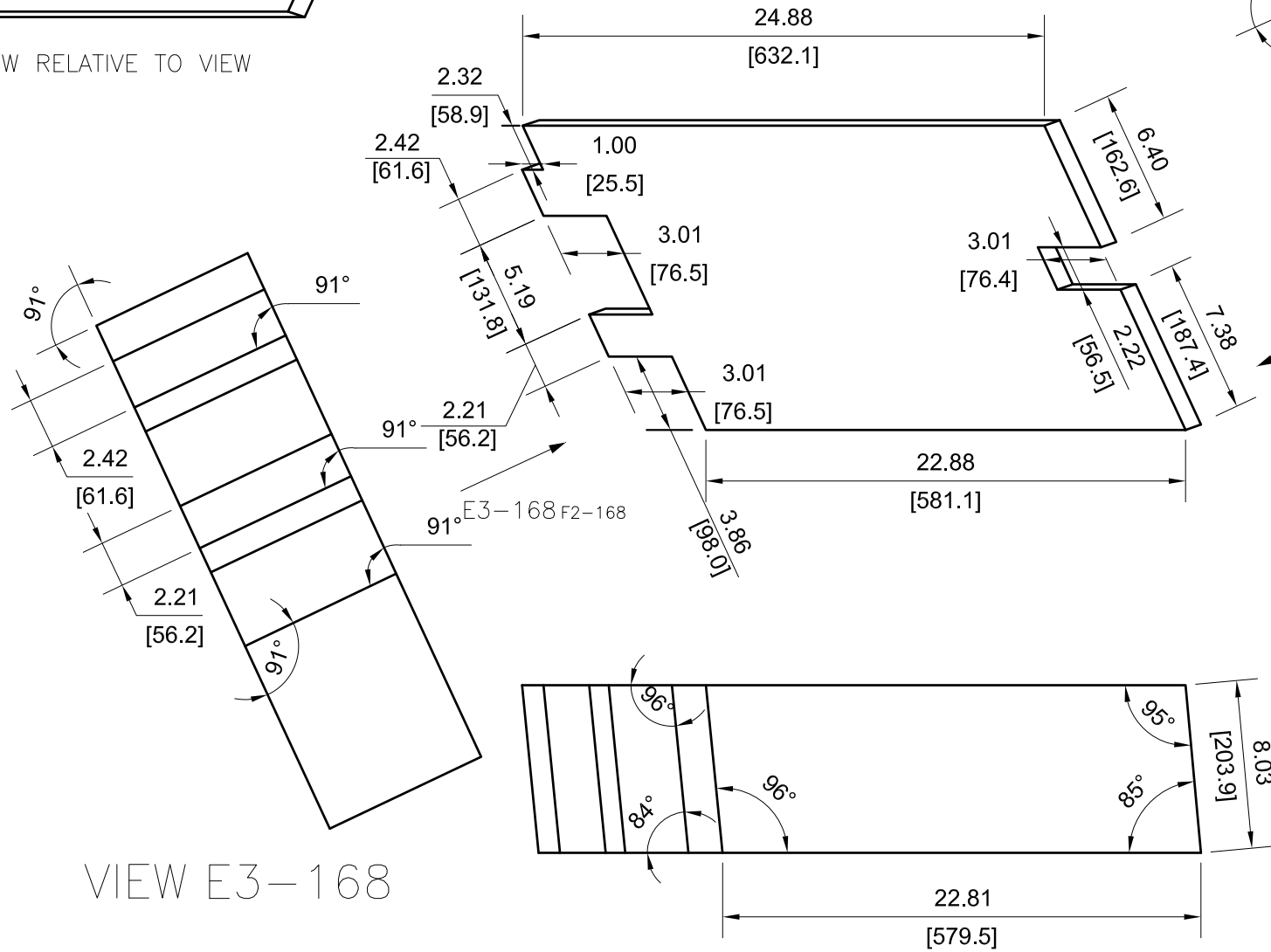

VIEW E3-168

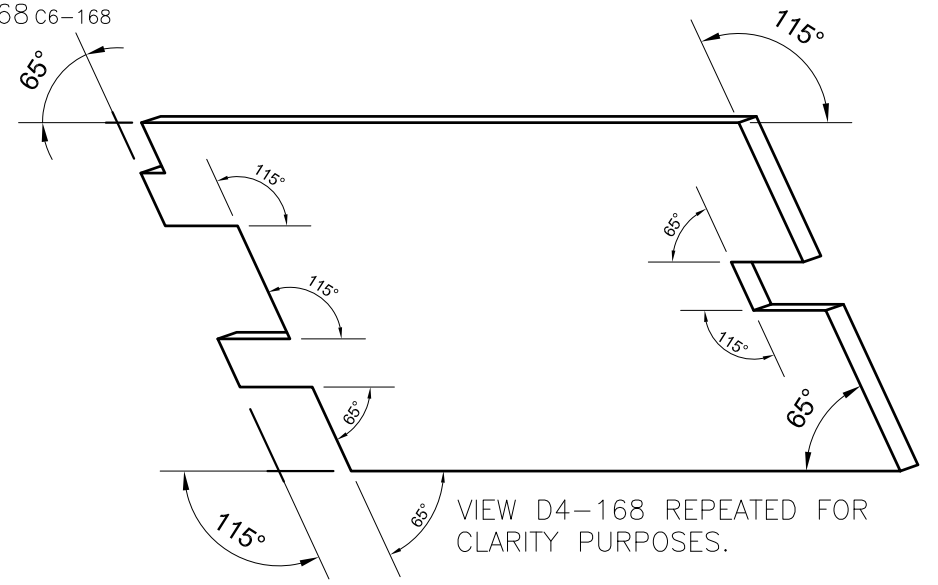

VIEW D4-168 REPEATED FOR CLARITY PURPOSES.



DRAWING NUMBER				
AES-D0008				
SIZE	SCALE	SHEET	OF	REVISION
A3	NONE	168	190	B

334

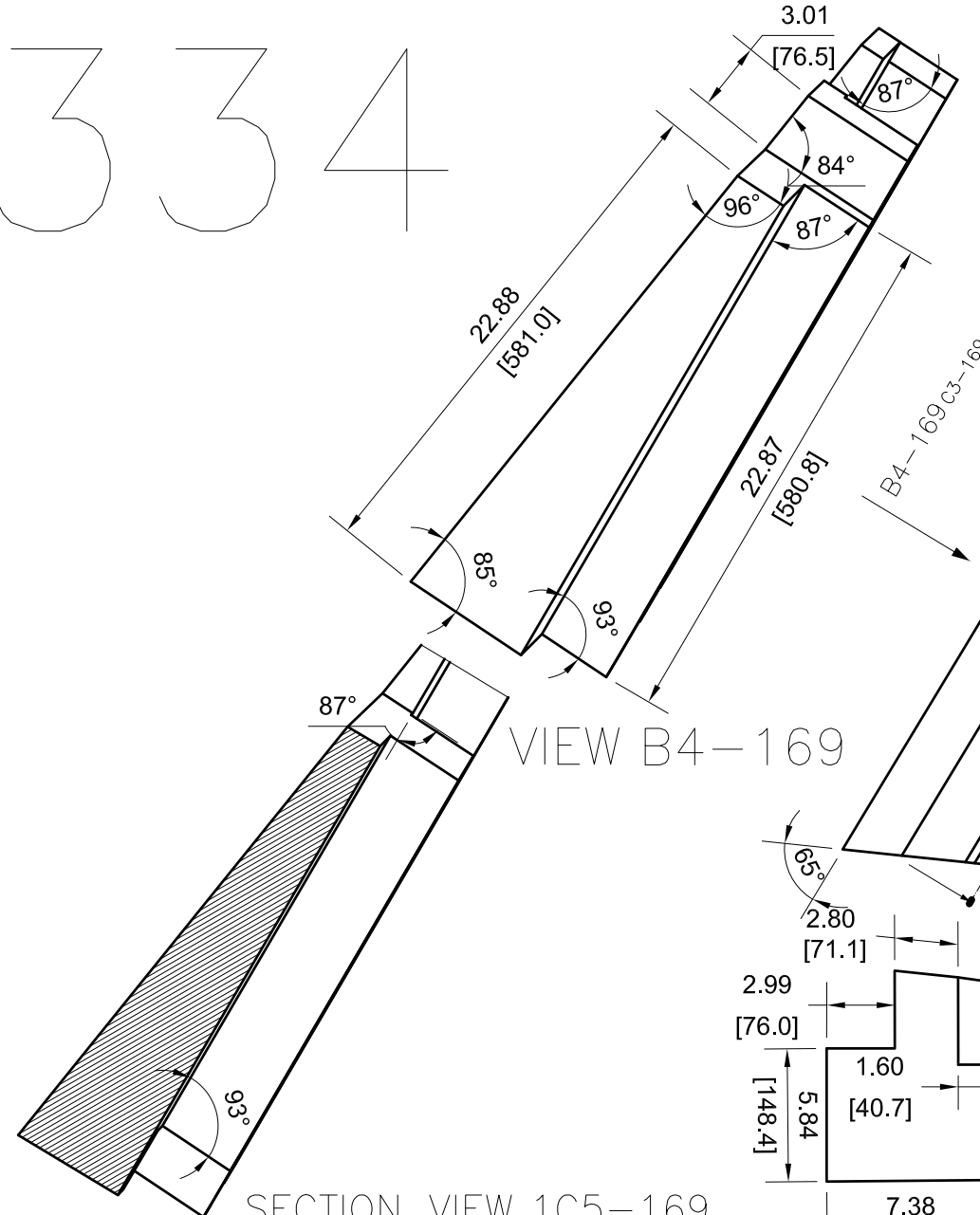

VIEW B4-169

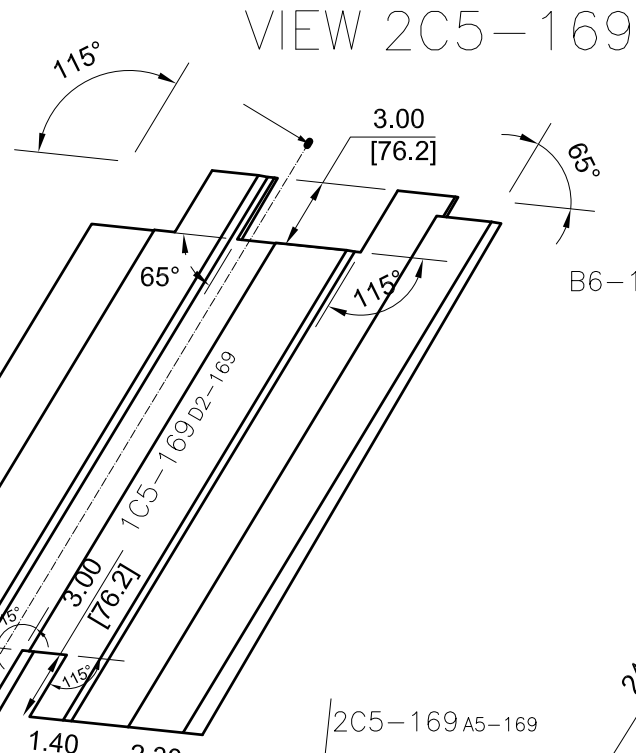

VIEW 2C5-169

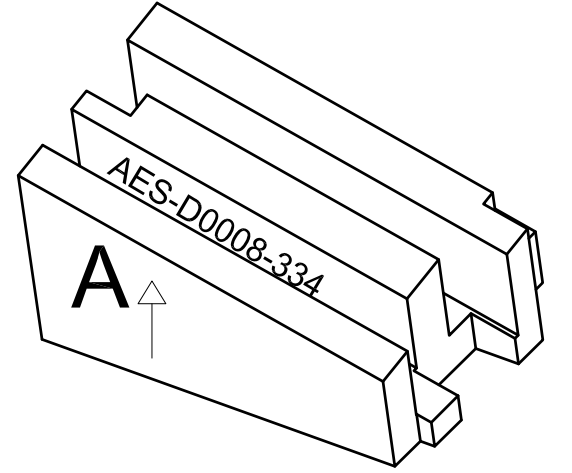

SECTION VIEW 1C5-169

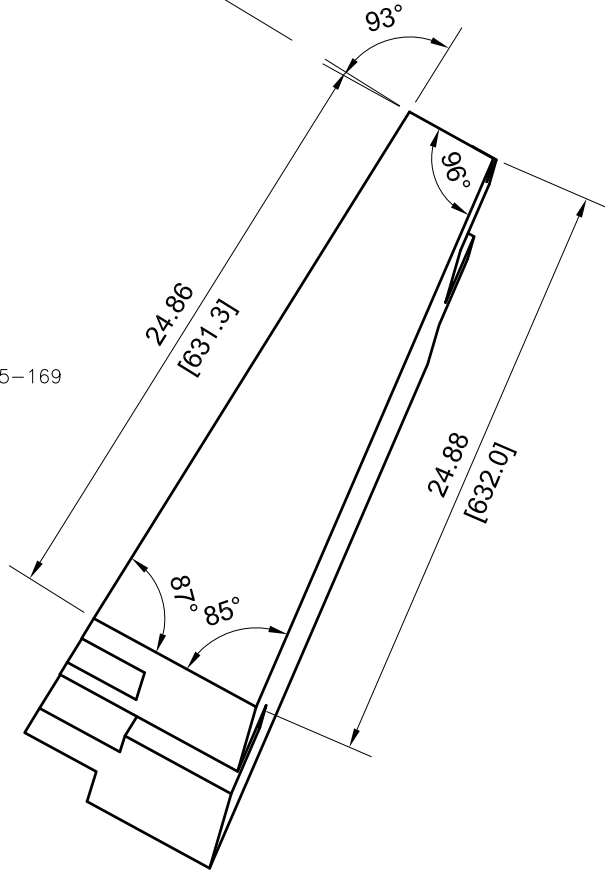

VIEW B6-169

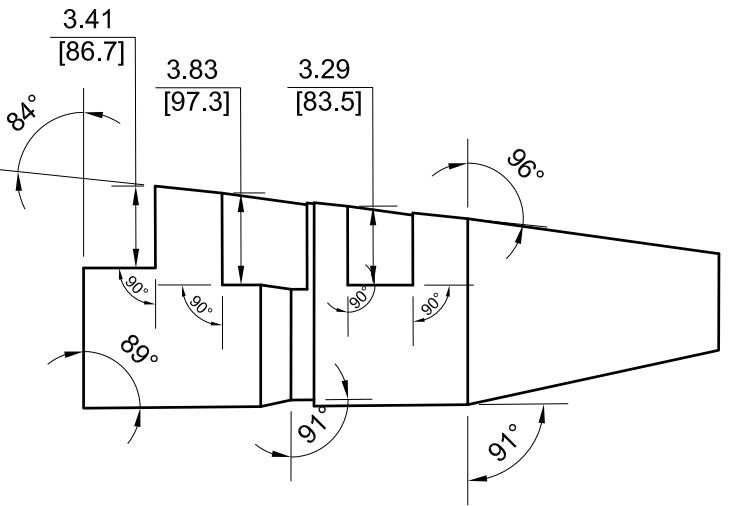

VIEW D4-169 REPEATED FOR CLARITY PURPOSES.

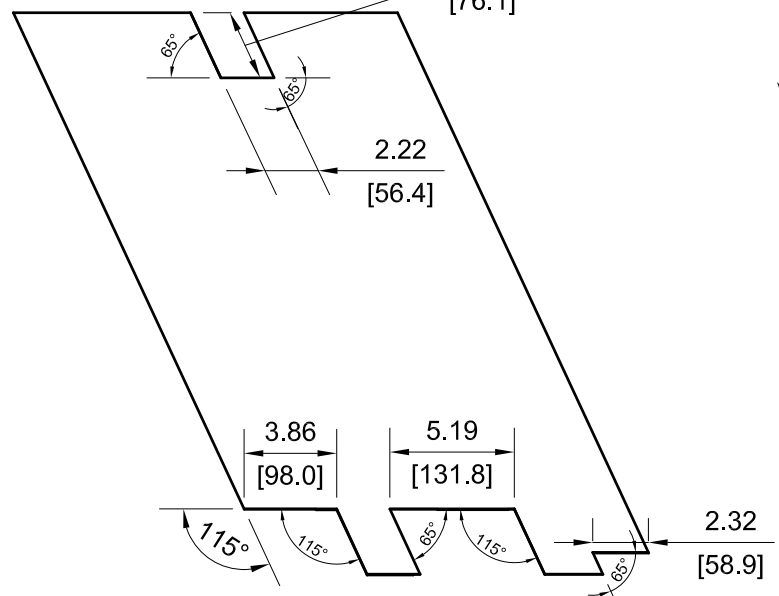

		DRAWING NUMBER			
		AES-D0008			
SIZE	SCALE	SHEET	OF	REVISION	
A3	NONE	169	190	B	

336

VIEW B5-170

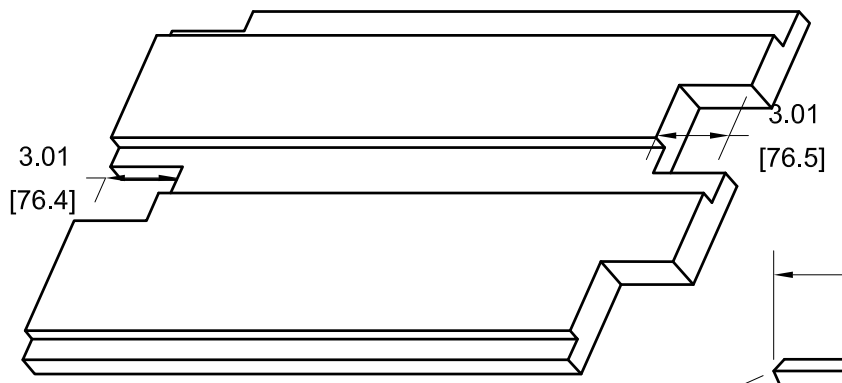
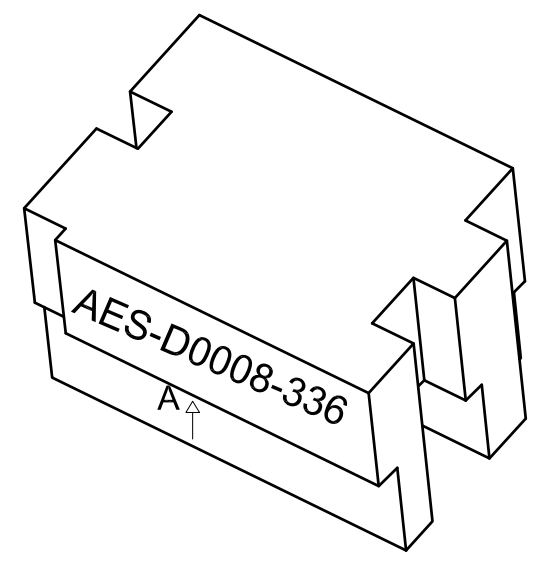
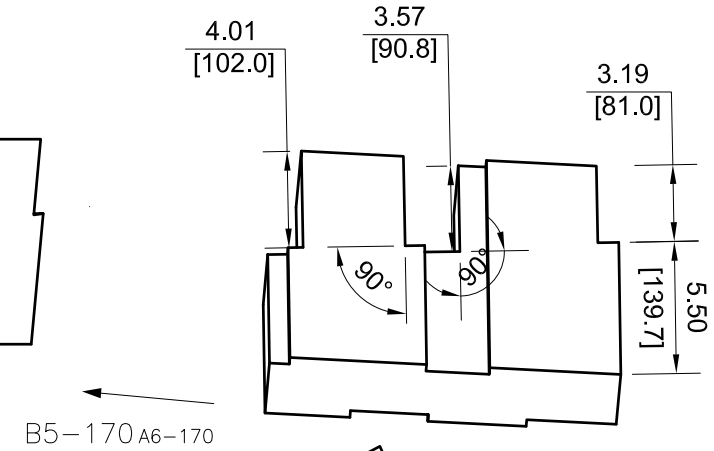
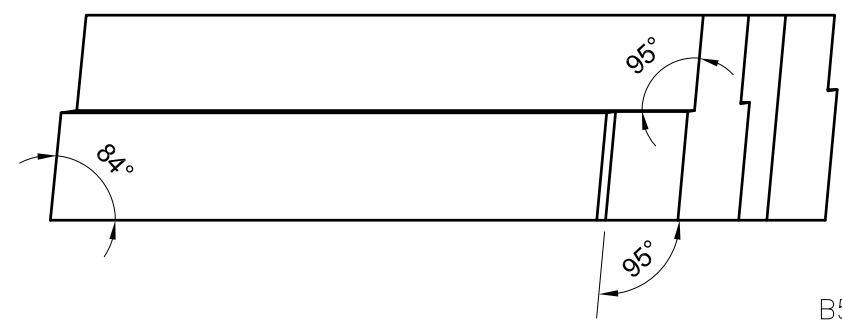

REAR VIEW RELATIVE TO VIEW D4-170

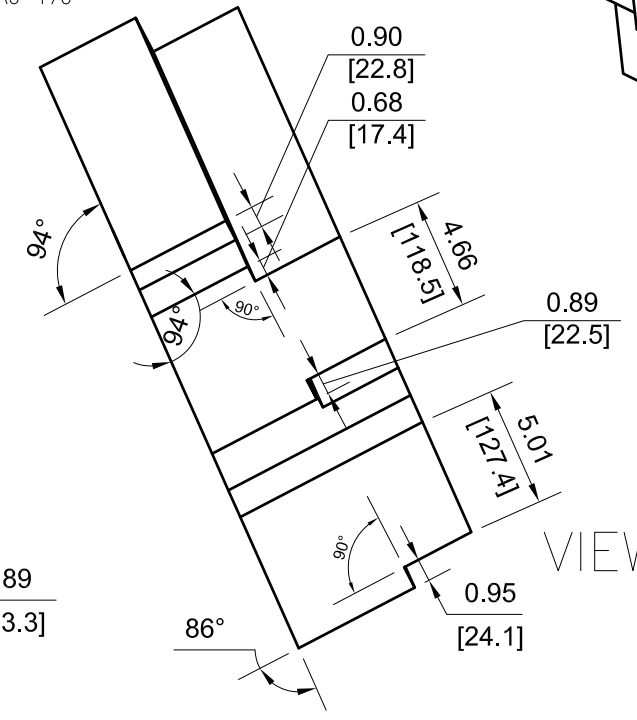

VIEW D5-170

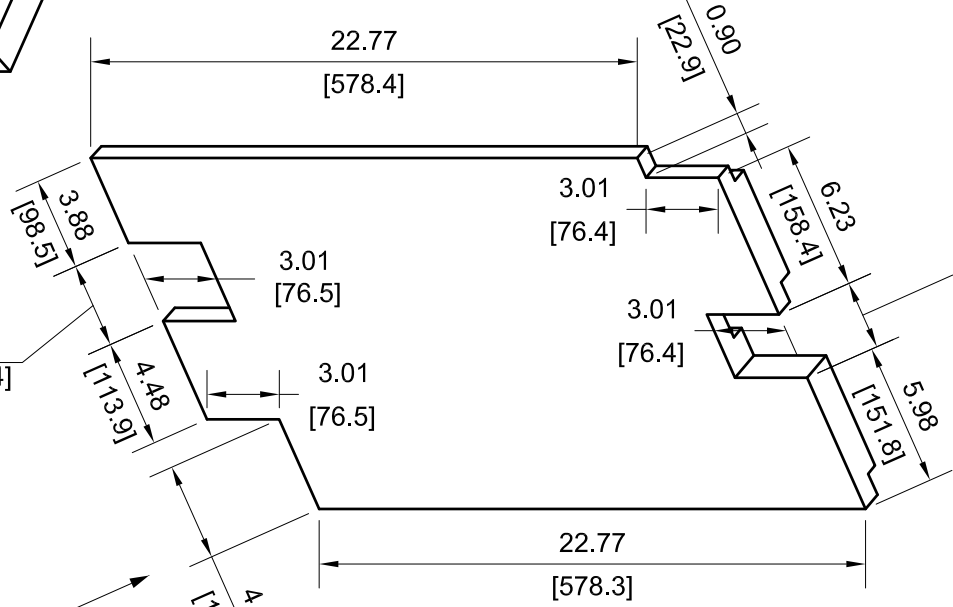

D5-170 D7-170

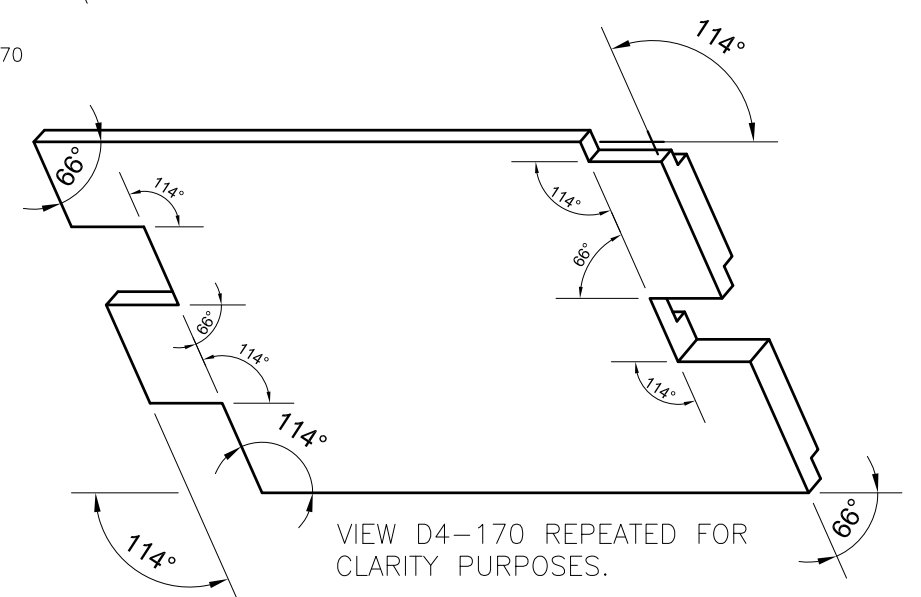

VIEW D4-170 REPEATED FOR CLARITY PURPOSES.

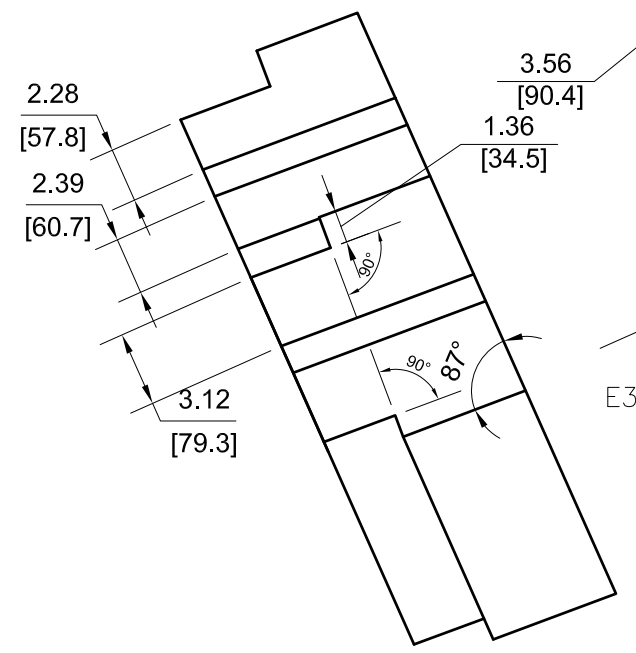

VIEW E3-170

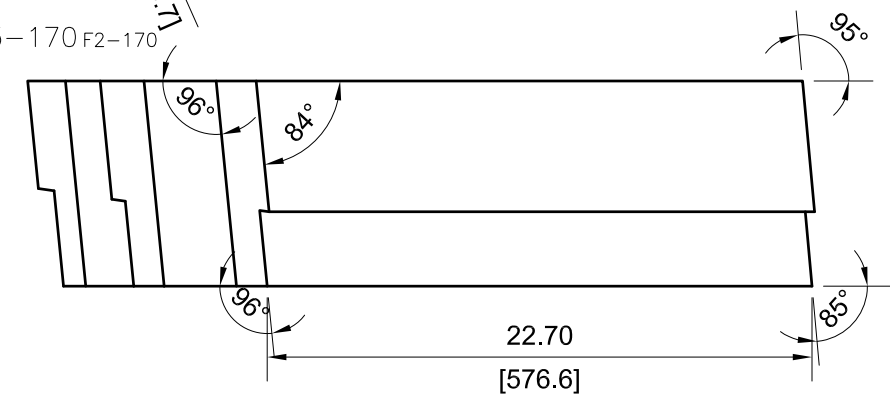

E3-170 F2-170



DRAWING NUMBER					AES-D0008	
SIZE	SCALE	SHEET	OF	REVISION		
A3	NONE	170	190	B		

338

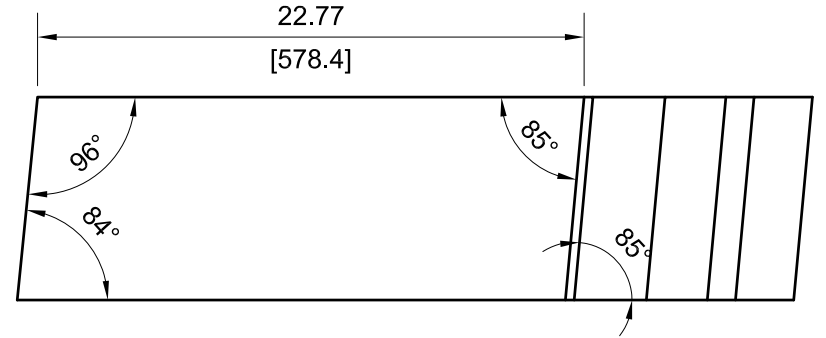

VIEW B5-171

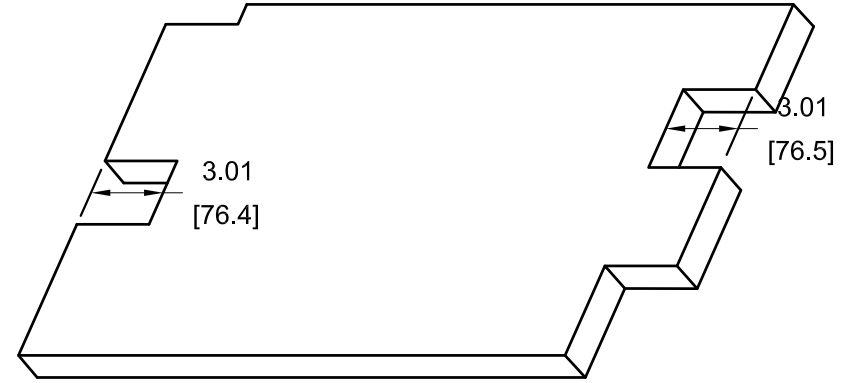
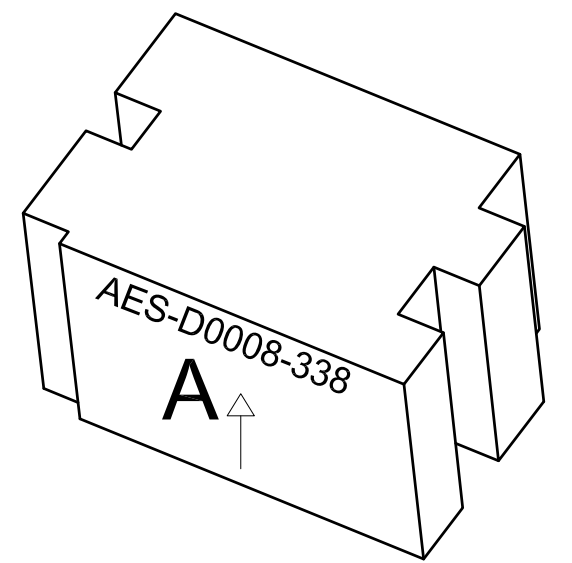
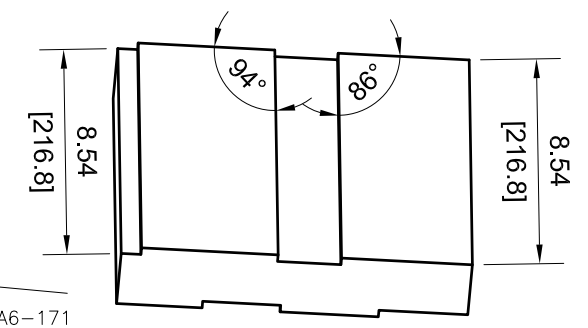

REAR VIEW RELATIVE TO VIEW E4-171

B5-171A6-171

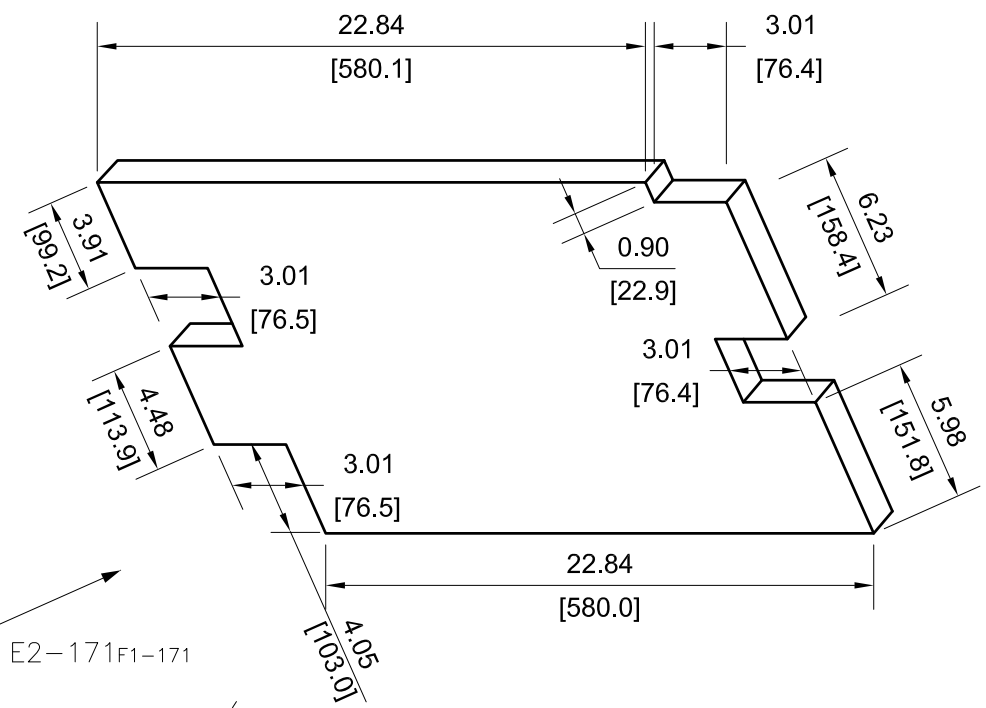

VIEW E5-171

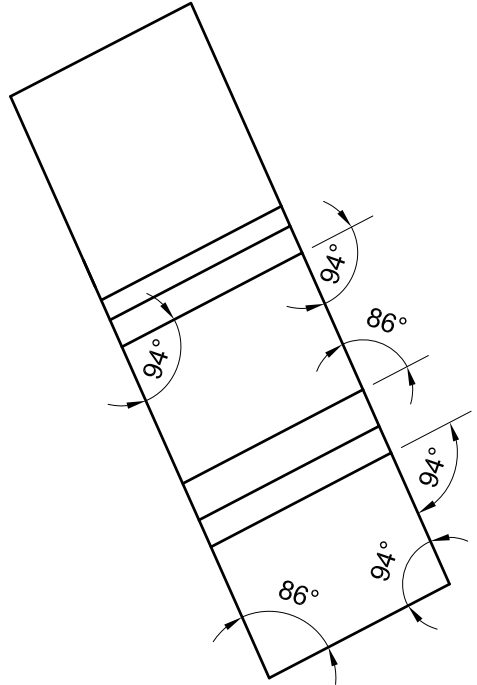

E5-171D6-171

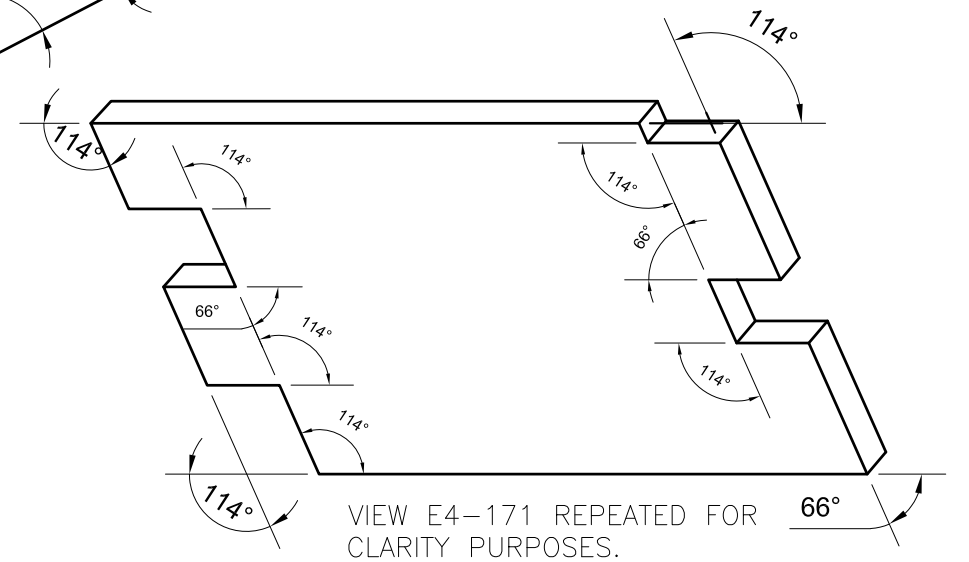

VIEW E4-171 REPEATED FOR CLARITY PURPOSES.

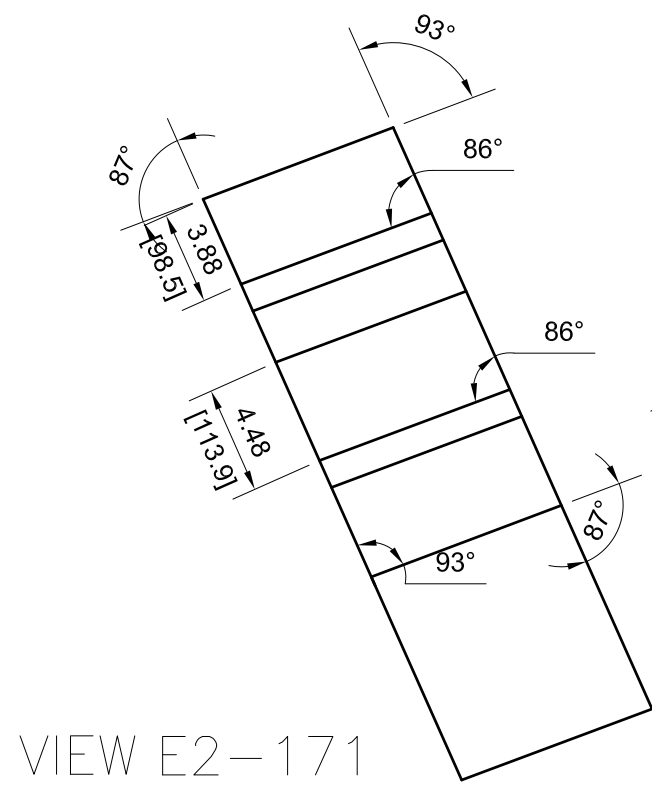

VIEW E2-171

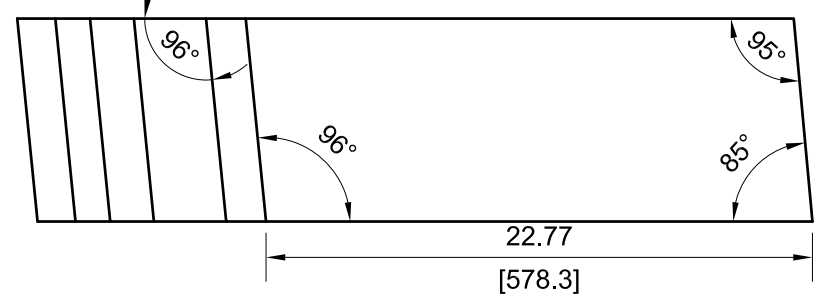

E2-171F1-171



DRAWING NUMBER				
AES-D0008				
SIZE	SCALE	SHEET	OF	REVISION
A3	NONE	171	190	B

340

VIEW B5-172

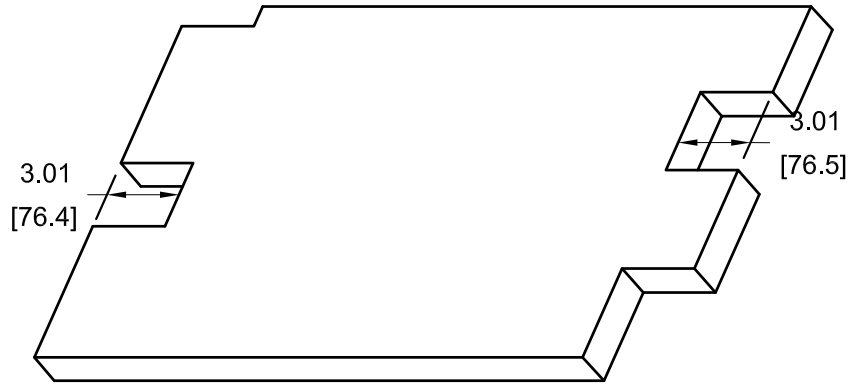
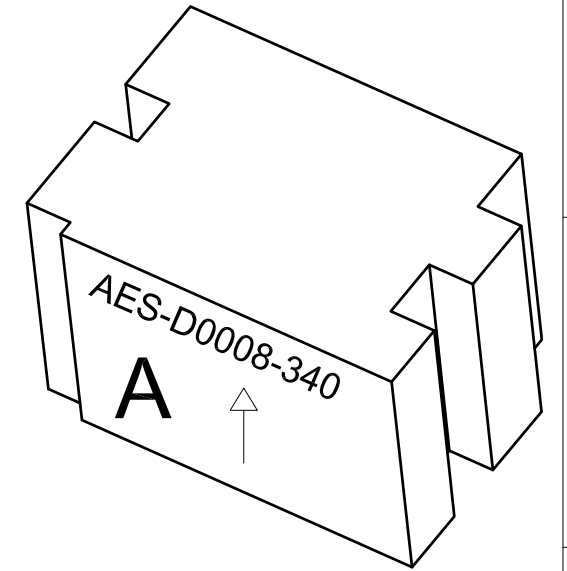
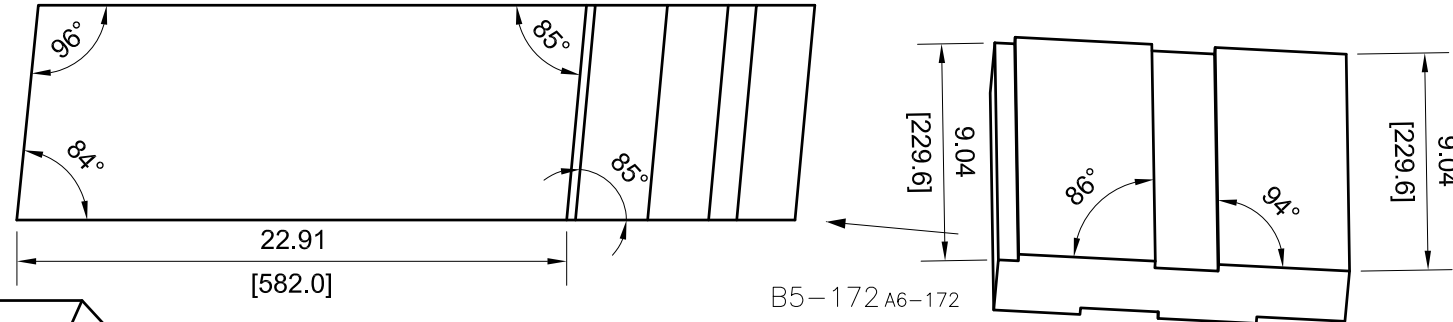

REAR VIEW RELATIVE TO VIEW D4-172

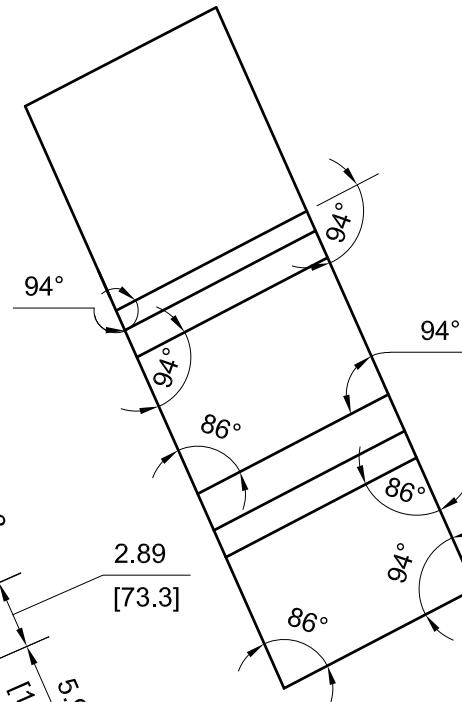

VIEW E5-172

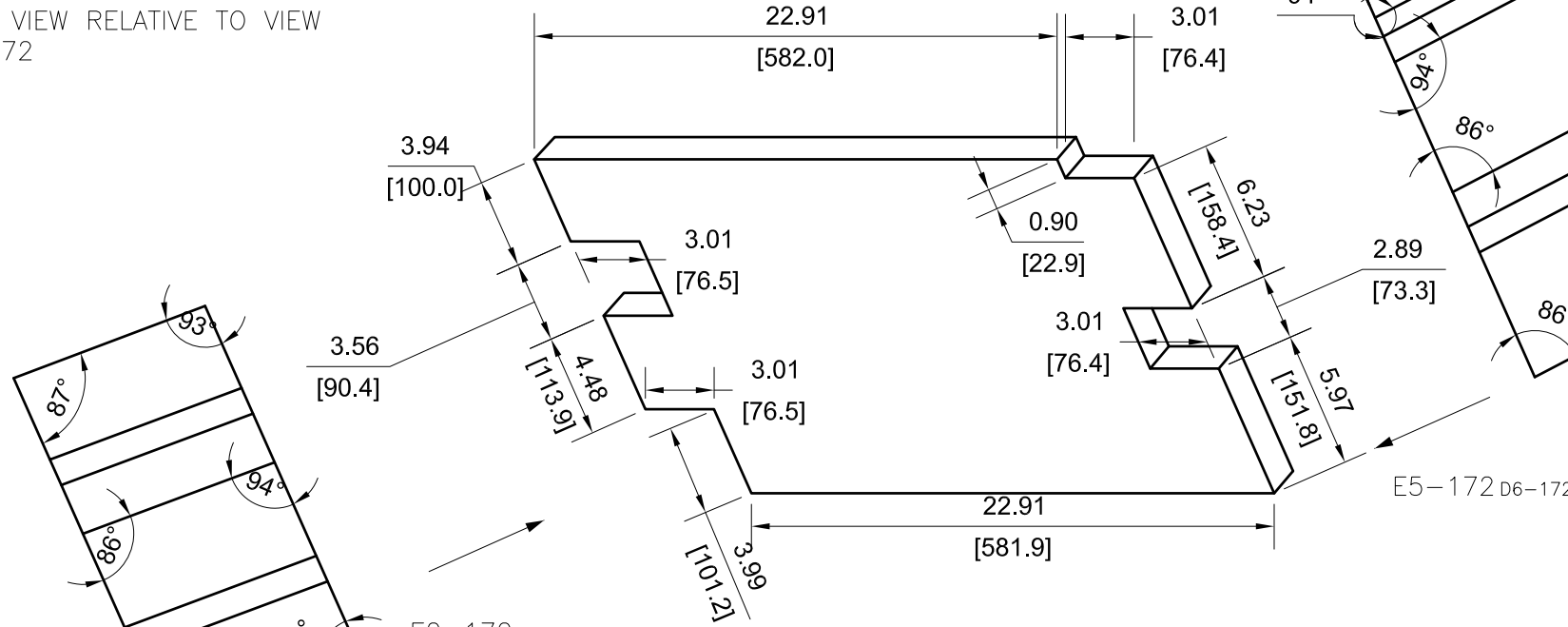

VIEW E2-172

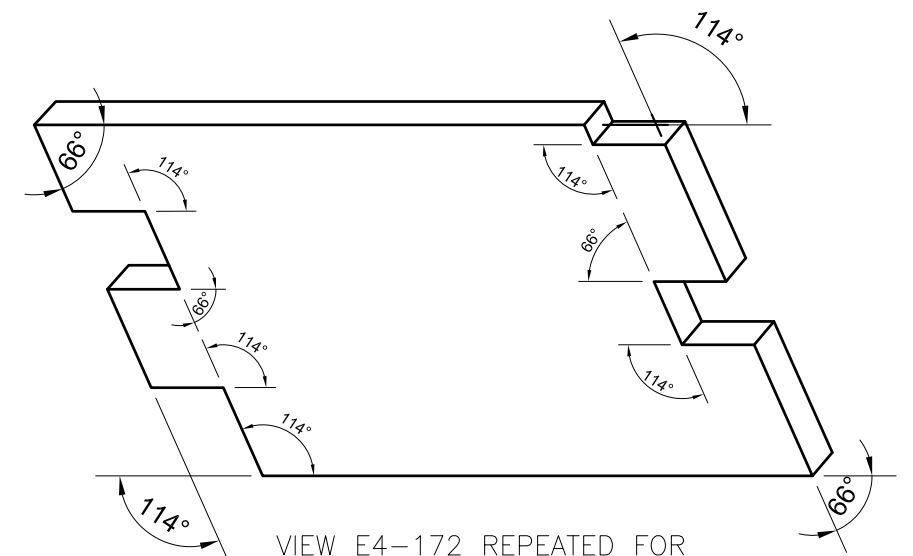
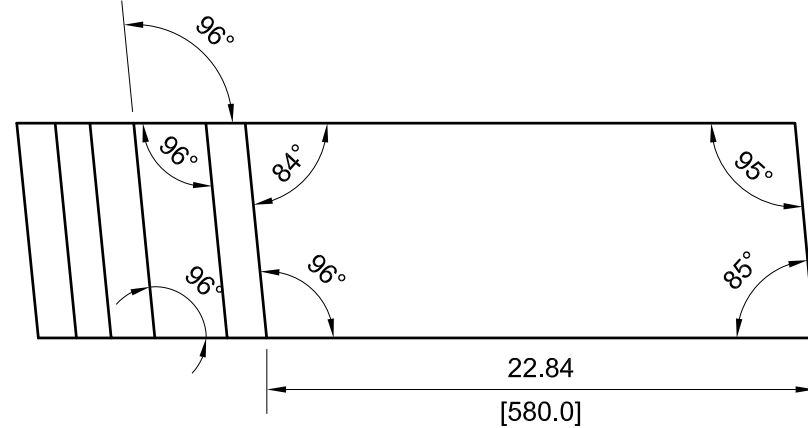

VIEW E4-172 REPEATED FOR CLARITY PURPOSES.



DRAWING NUMBER					AES-D0008	
SIZE	SCALE	SHEET	OF	REVISION		
A3	NONE	172	190	B		

342

VIEW B5-173

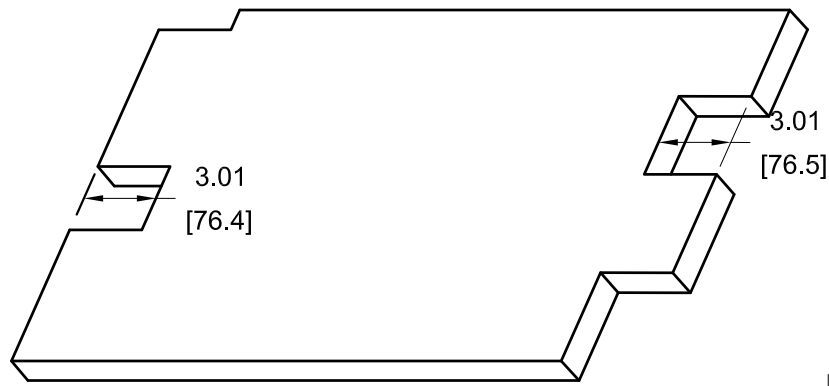
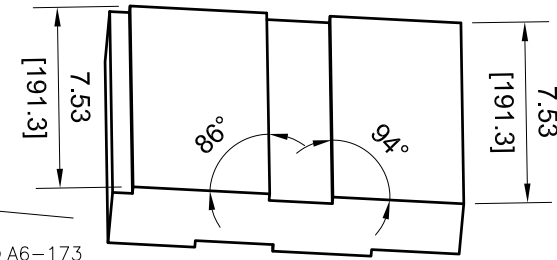
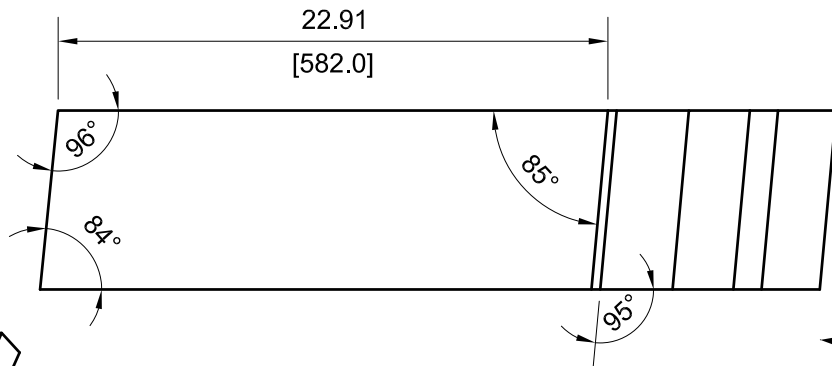
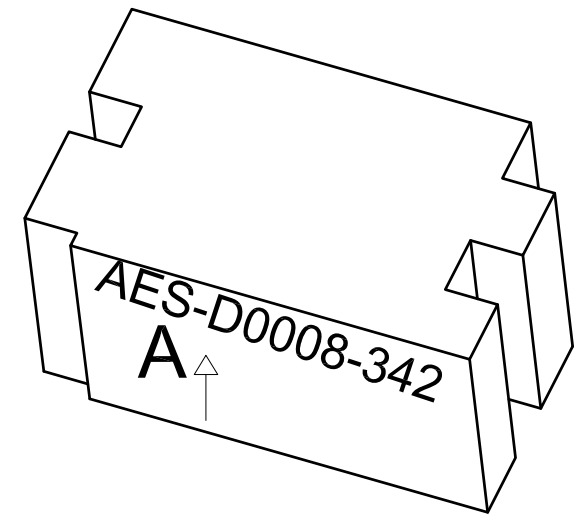

REAR VIEW RELATIVE TO VIEW D4-173

B5-173A6-173

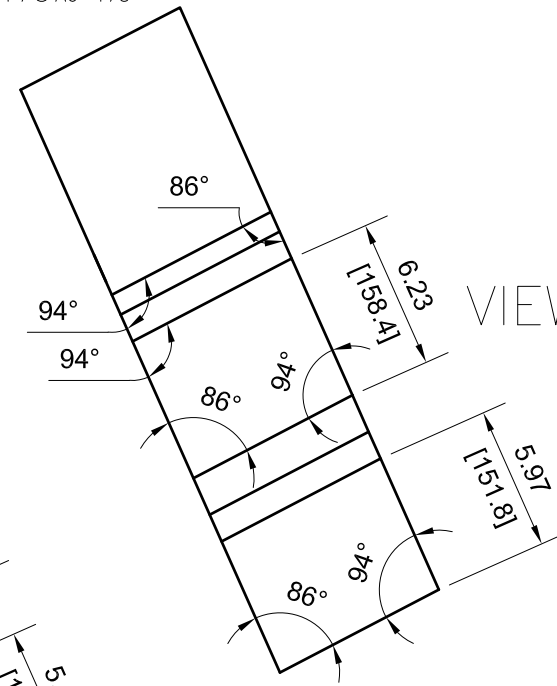

VIEW E5-173

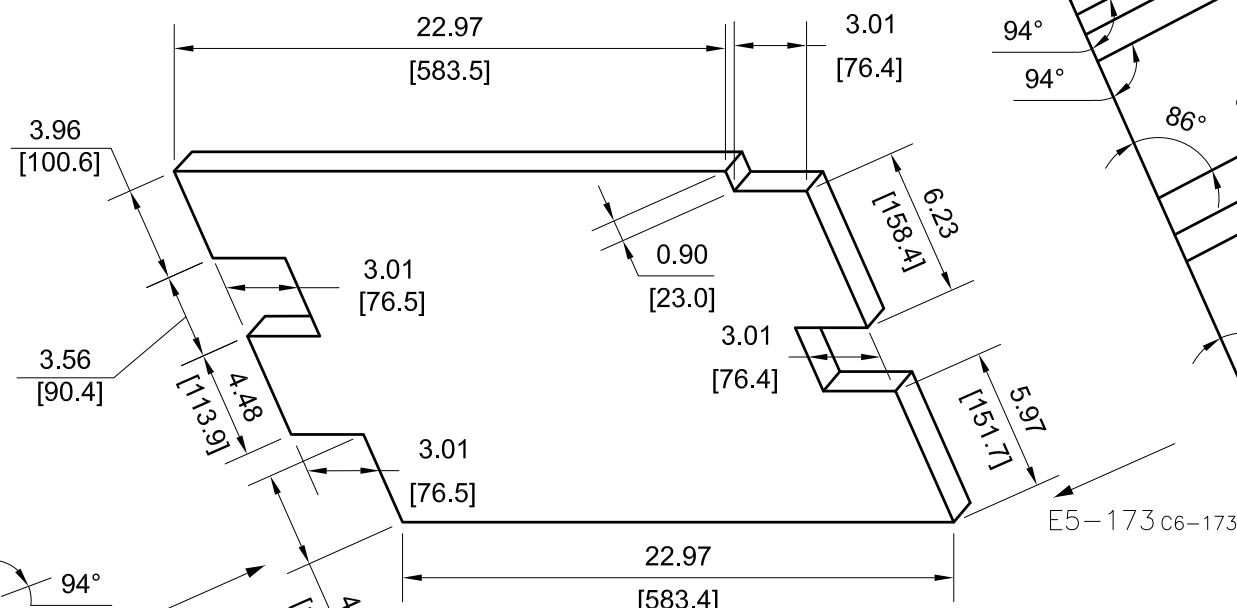

E3-173F2-173

E5-173C6-173

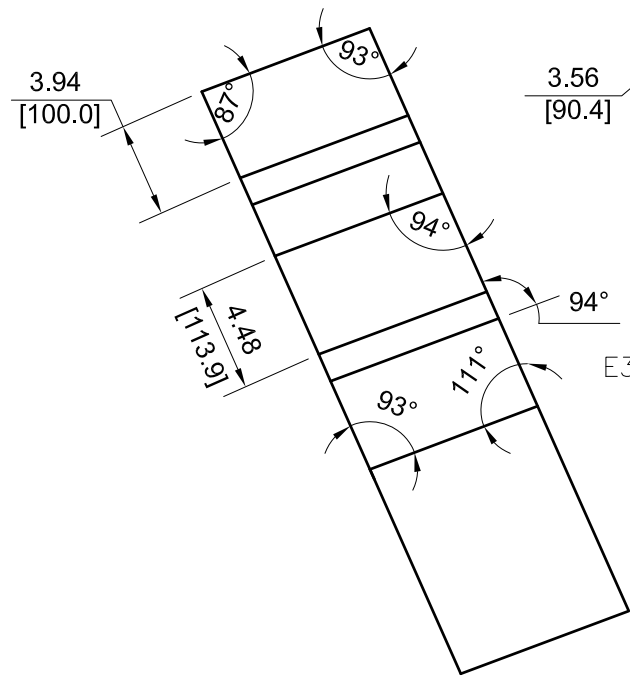

VIEW E3-173

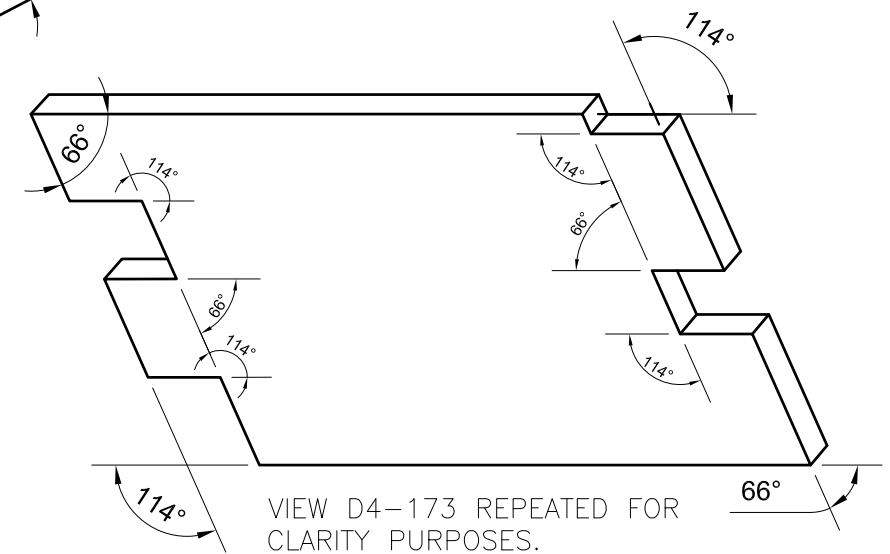
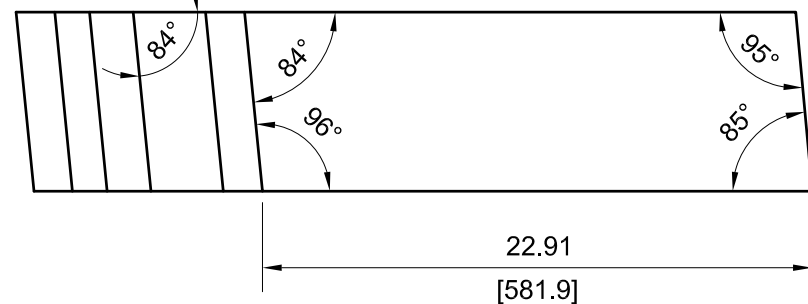

VIEW D4-173 REPEATED FOR CLARITY PURPOSES.



DRAWING NUMBER					AES-D0008	
SIZE	SCALE	SHEET	OF	REVISION		
A3	NONE	173	190	B		

344

VIEW B5-174

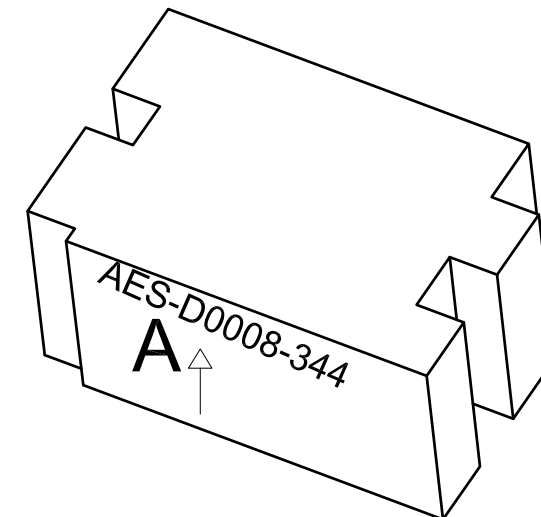
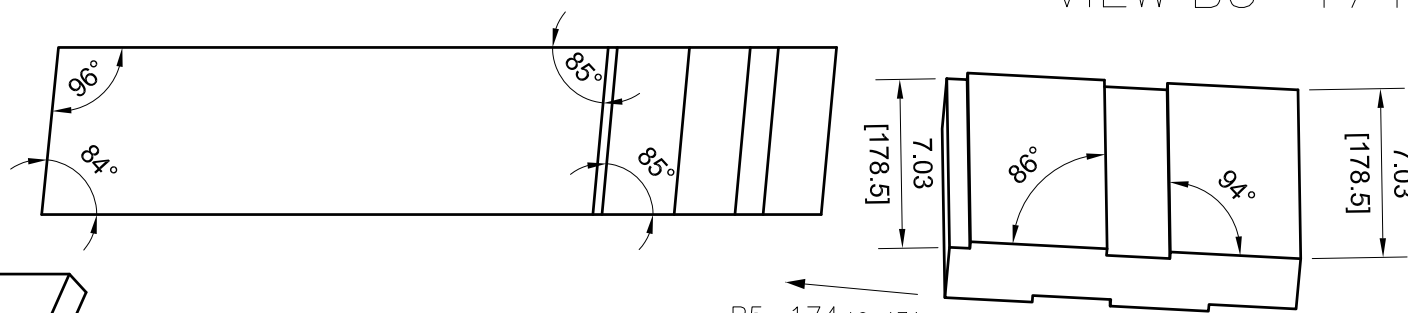

B5-174 A6-174

VIEW D5-174

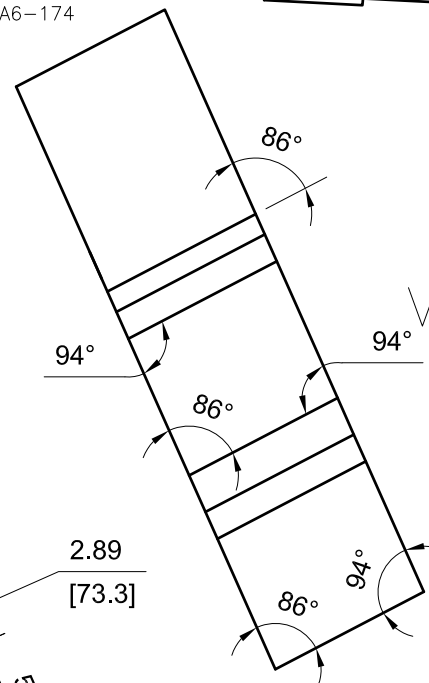

D5-174 C6-174

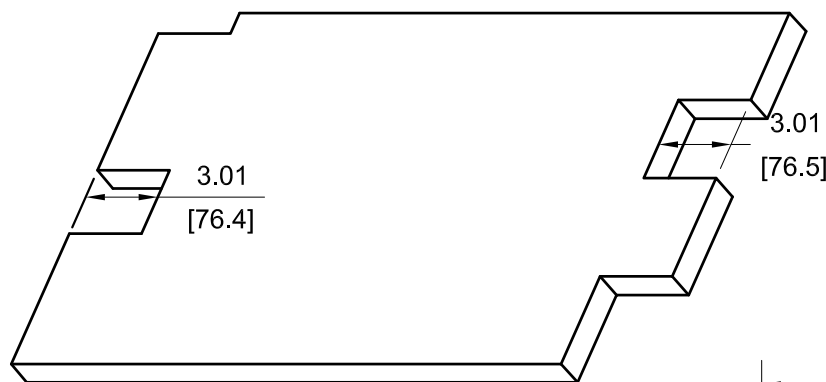

REAR VIEW RELATIVE TO VIEW D4-174

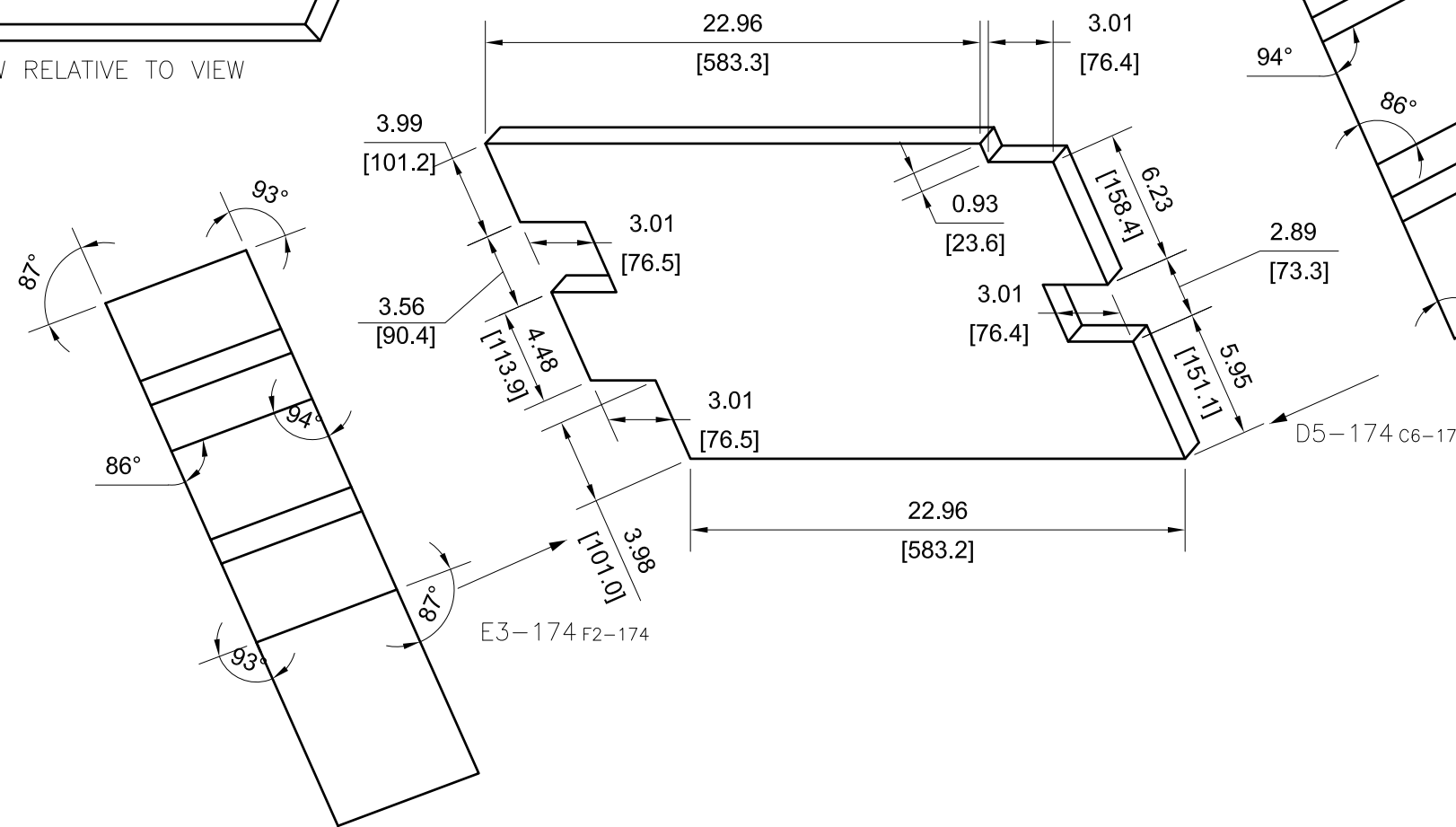

VIEW E3-174

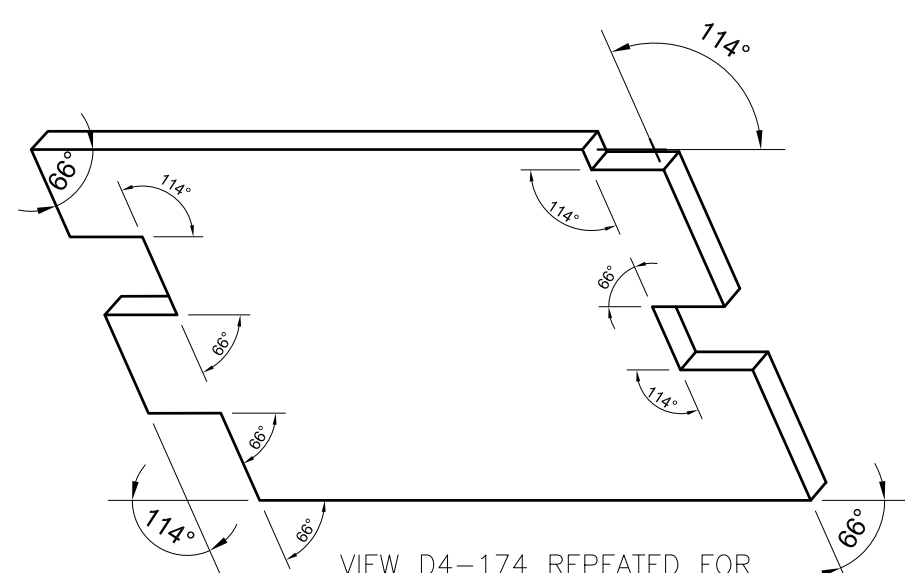
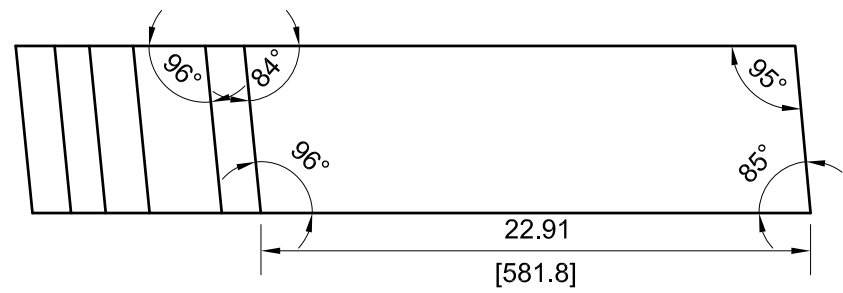
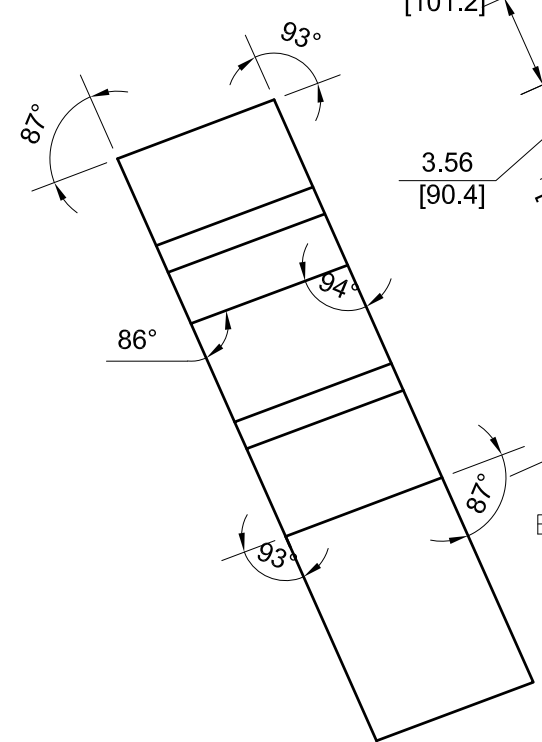

VIEW D4-174 REPEATED FOR CLARITY PURPOSES.



DRAWING NUMBER					AES-D0008	
SIZE	SCALE	SHEET	OF	REVISION		
A3	NONE	174	190	B		

348

VIEW B5-176

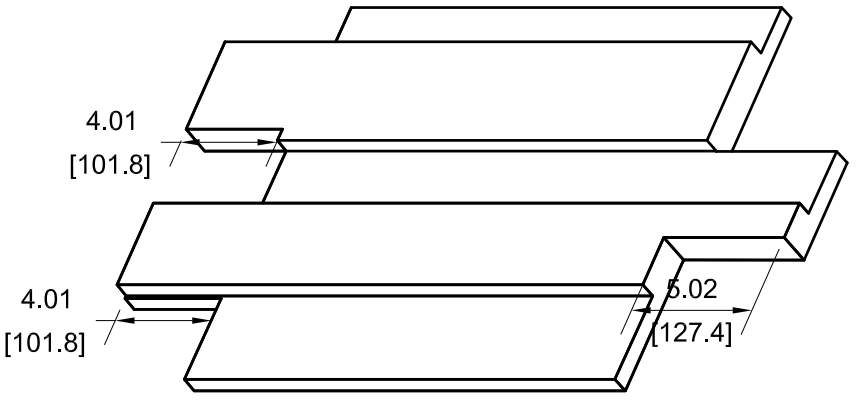
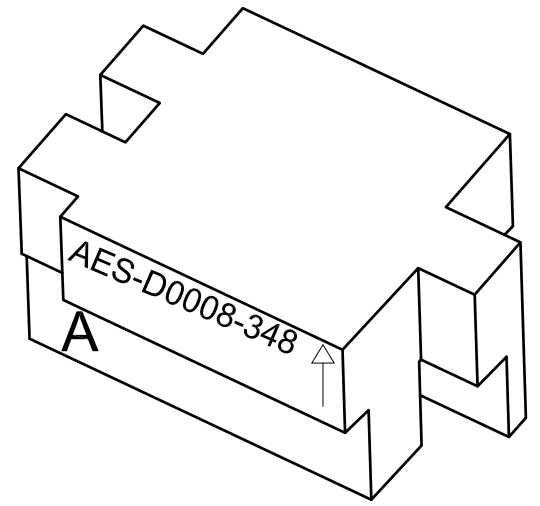
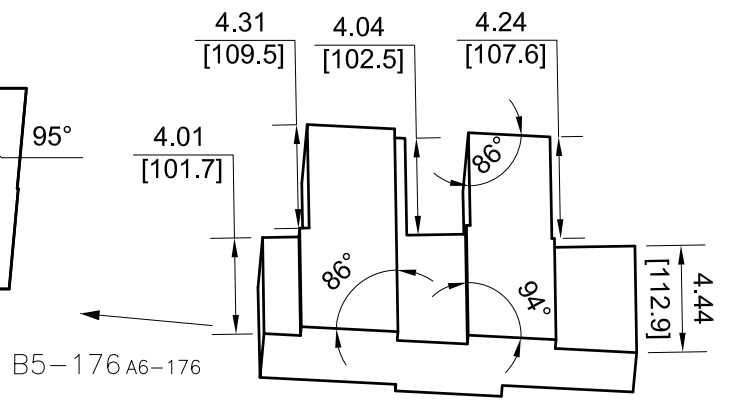
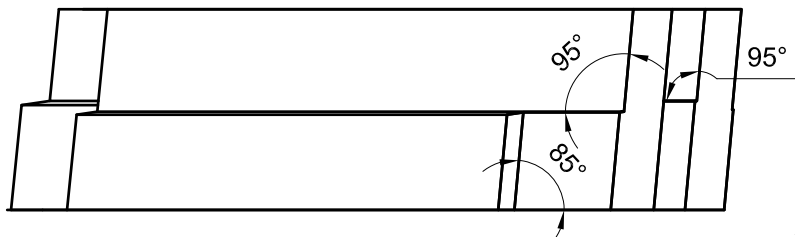

VIEW E5-176

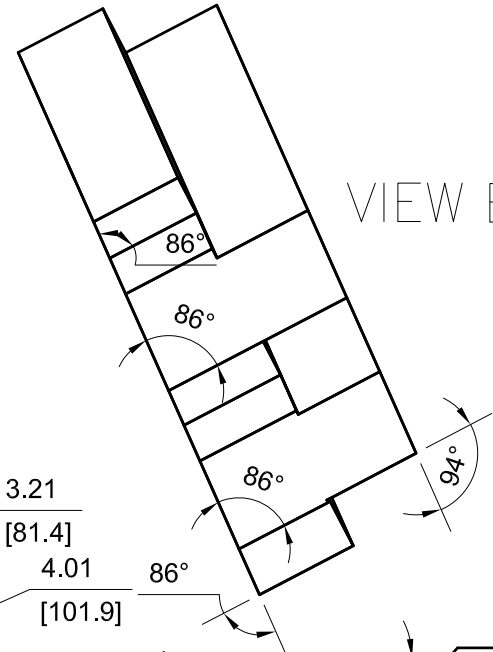

REAR VIEW RELATIVE TO VIEW D4-176

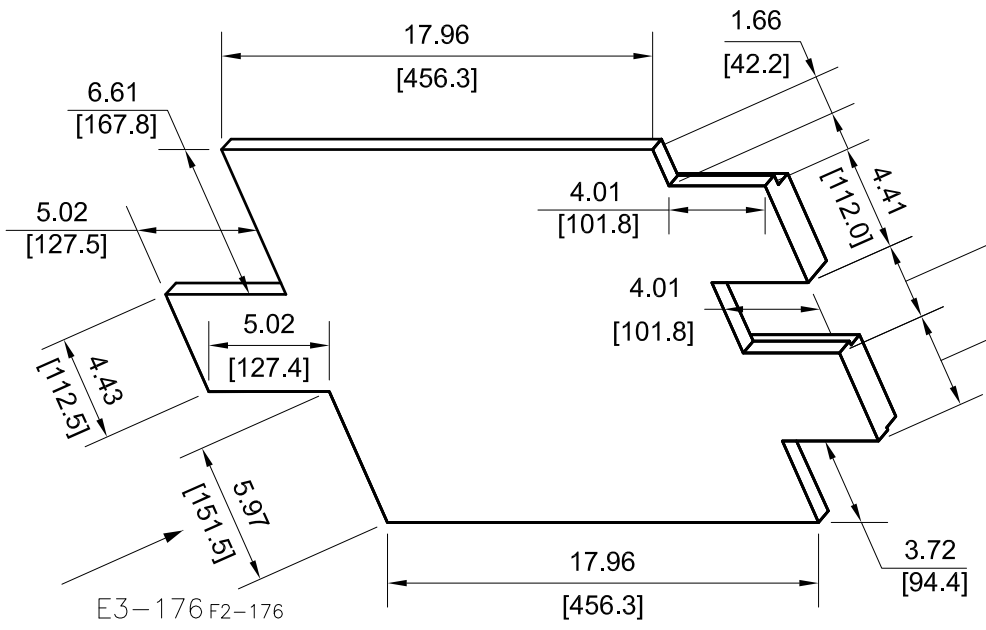

E5-176 C6-176

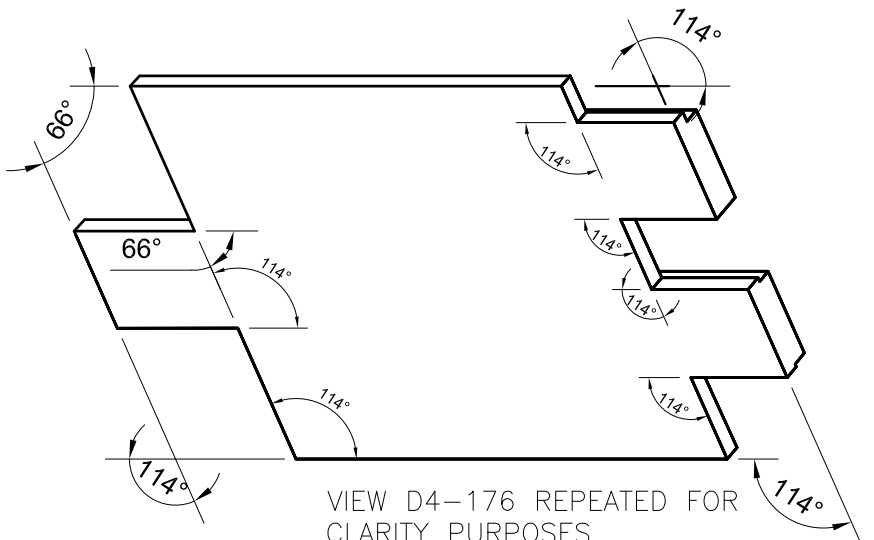

VIEW D4-176 REPEATED FOR CLARITY PURPOSES.

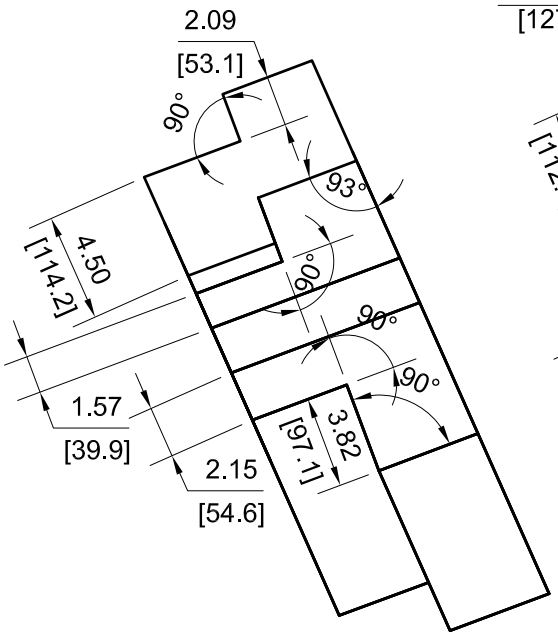

VIEW E3-176

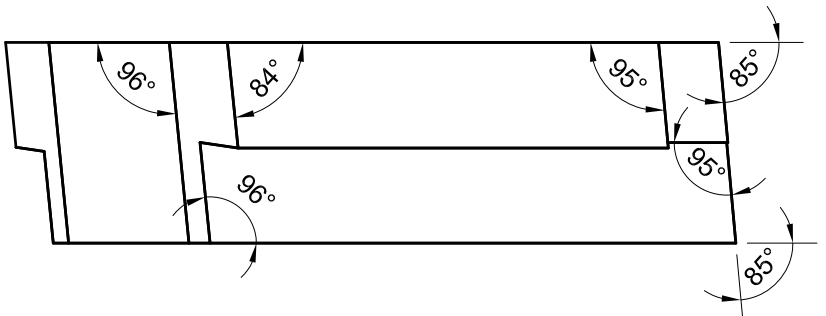

DRAWING NUMBER					AES-D0008	
SIZE	SCALE	SHEET	OF	REVISION		
A3	NONE	176	190	B		

350

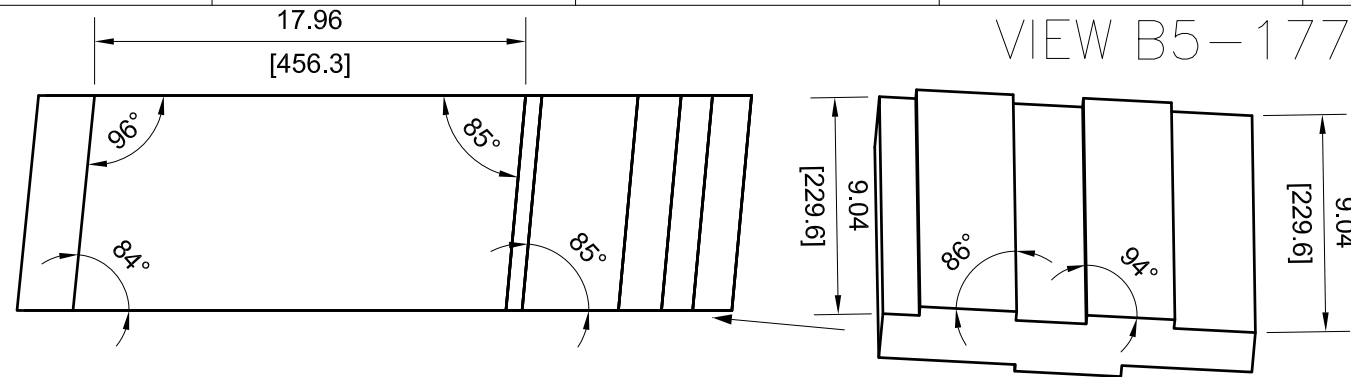

B5-177 A6-177

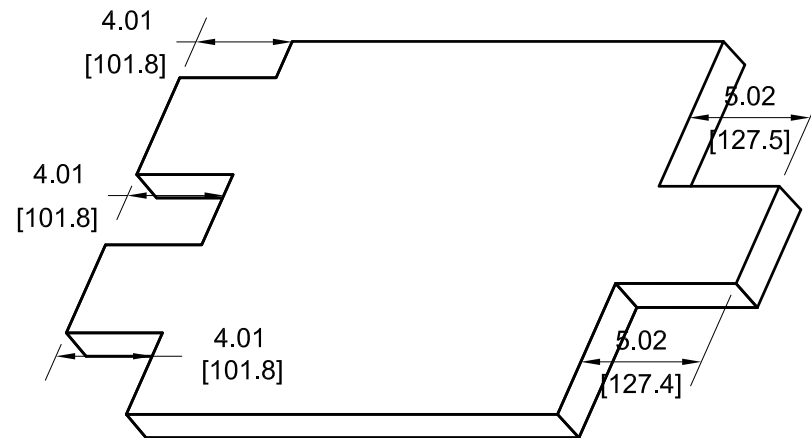
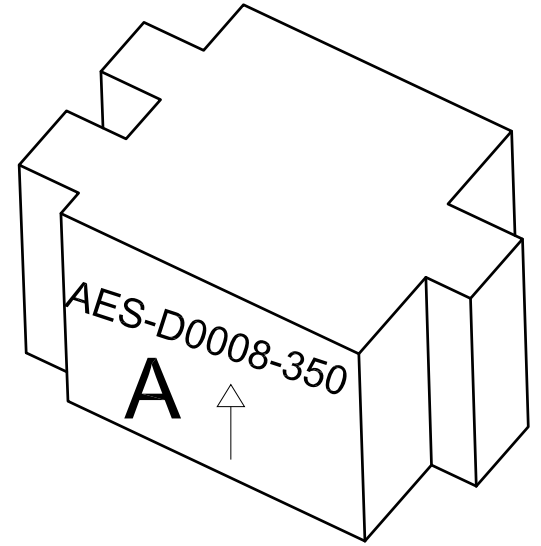

REAR VIEW RELATIVE TO VIEW D4-177

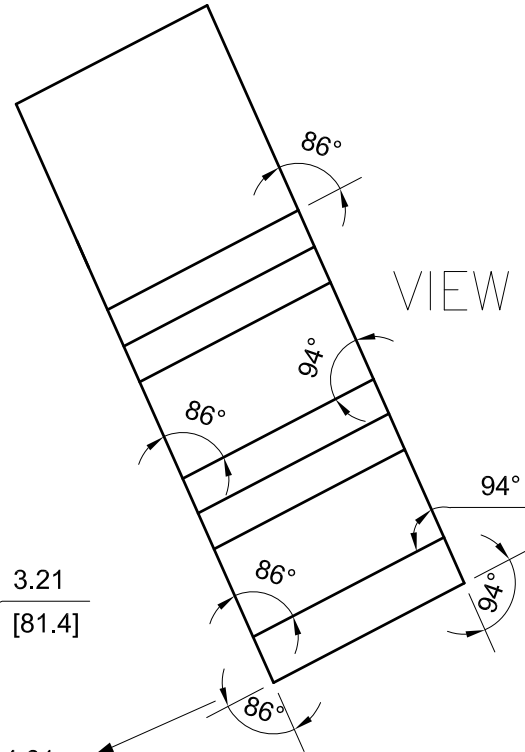

VIEW D6-177

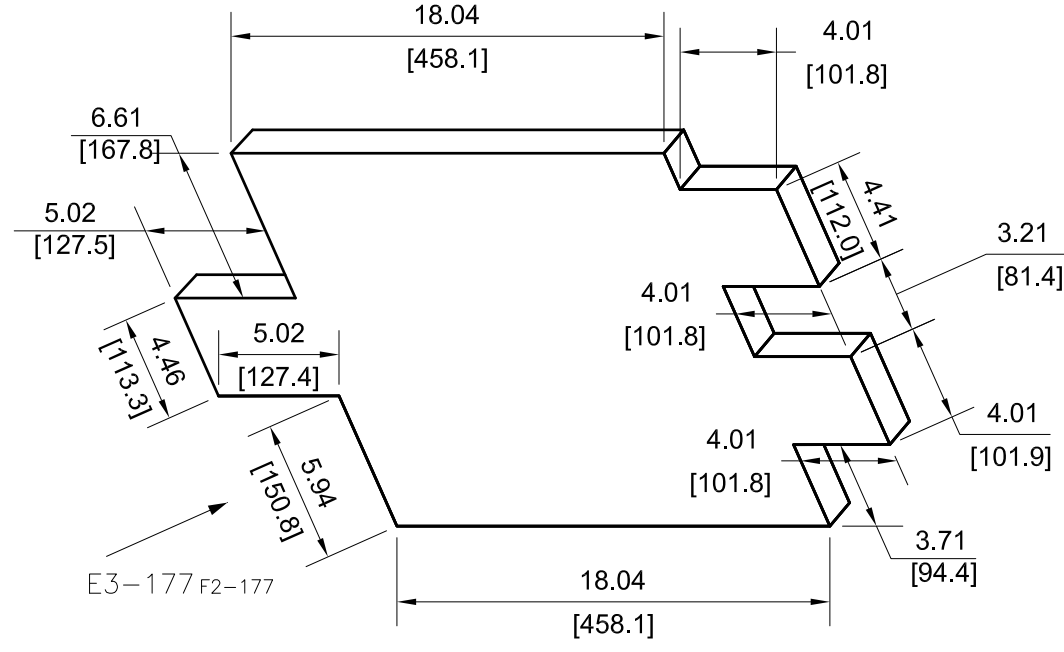

E3-177 F2-177

D6-177 C6-177

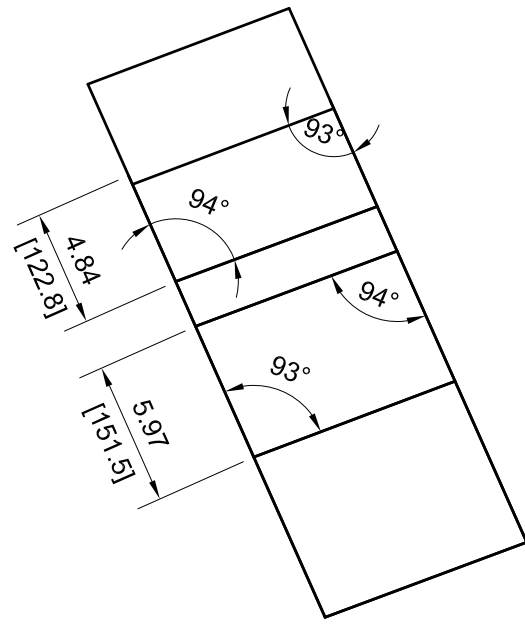

VIEW E3-177

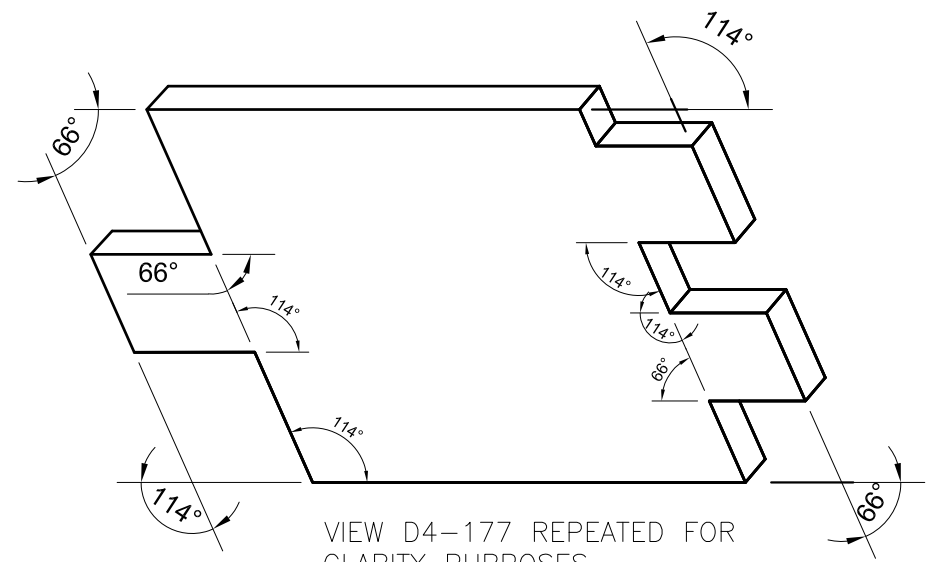
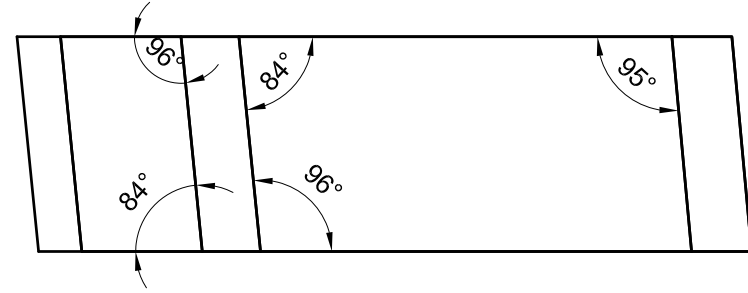

VIEW D4-177 REPEATED FOR CLARITY PURPOSES.



DRAWING NUMBER					AES-D0008	
SIZE	SCALE	SHEET	OF	REVISION		
A3	NONE	177	190	B		

352

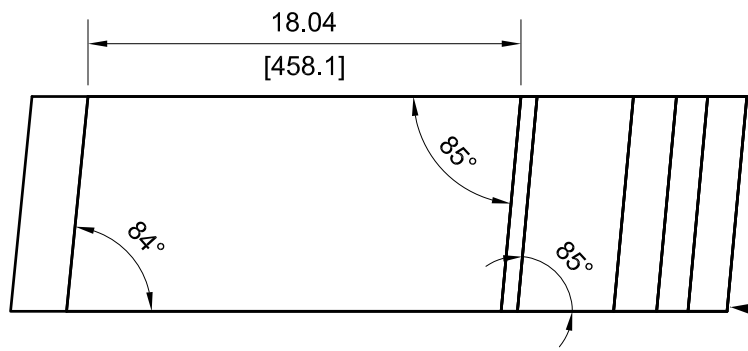

B5-178 A6-178

VIEW B5-178

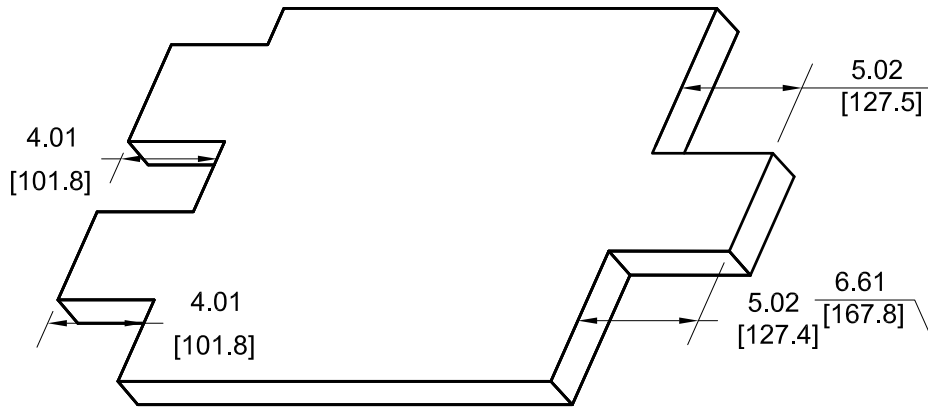
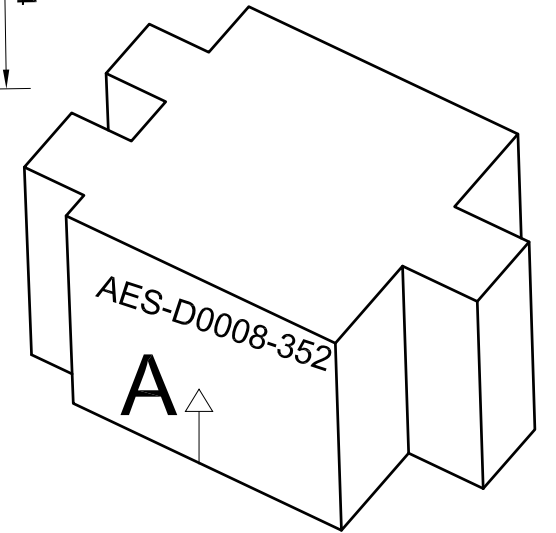
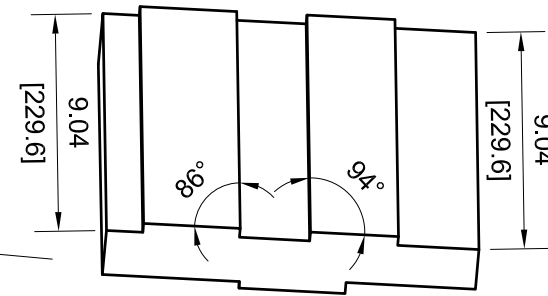

REAR VIEW RELATIVE TO VIEW D4-178

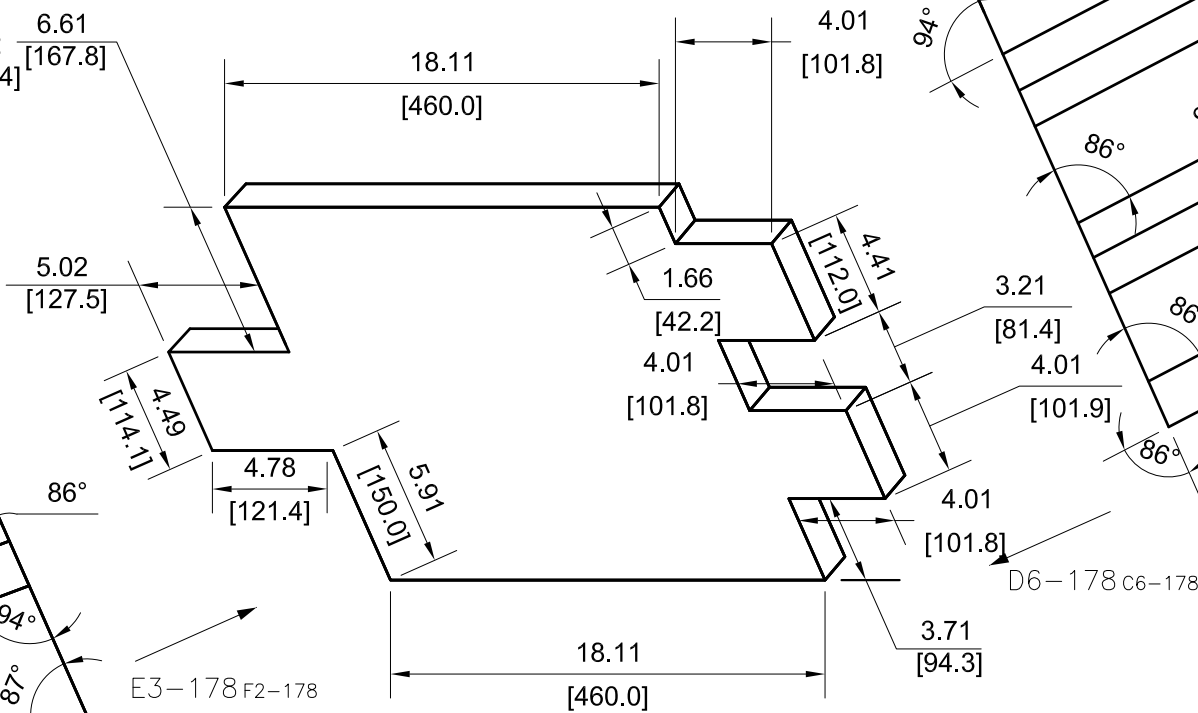

D6-178 C6-178

VIEW D6-178

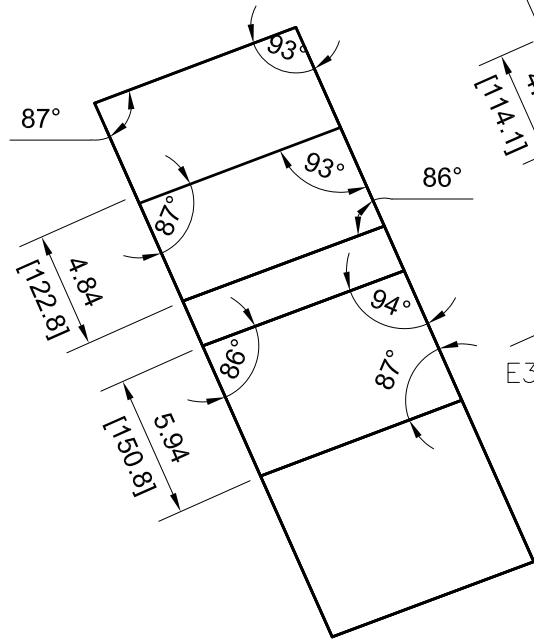

E3-178 F2-178

VIEW E3-178

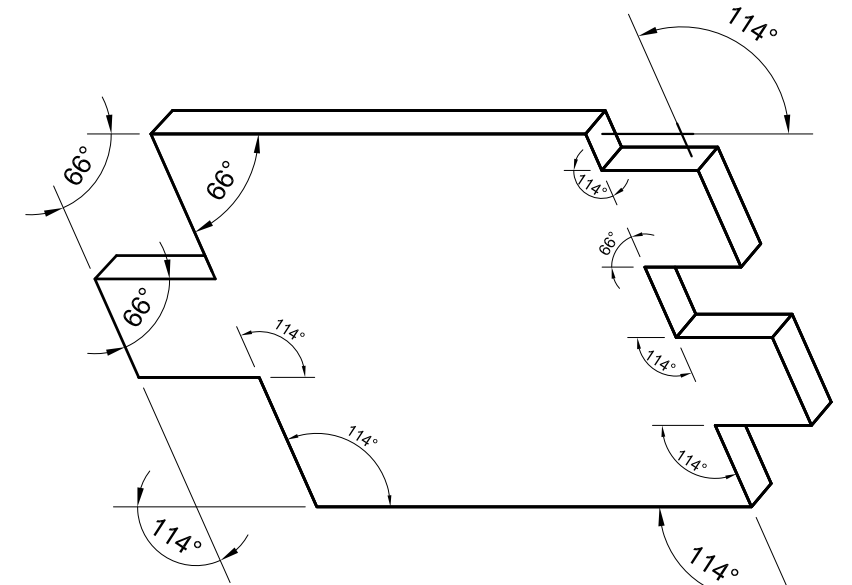
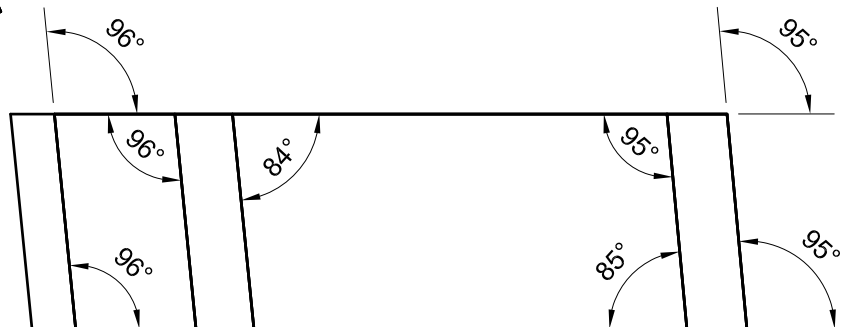

VIEW D4-178 REPEATED FOR CLARITY PURPOSES.



DRAWING NUMBER					AES-D0008	
SIZE	SCALE	SHEET	OF	REVISION		
A3	NONE	178	190	B		

354

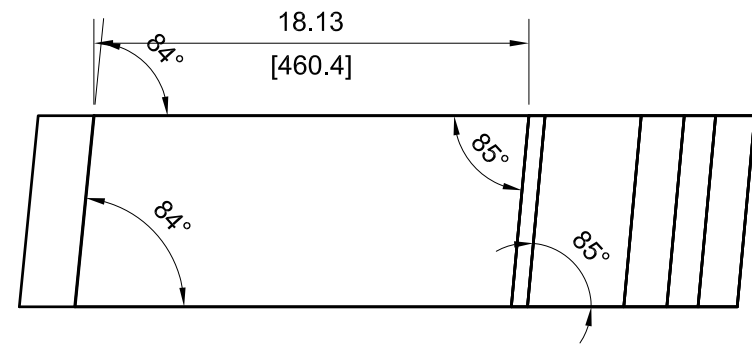

VIEW B5-179

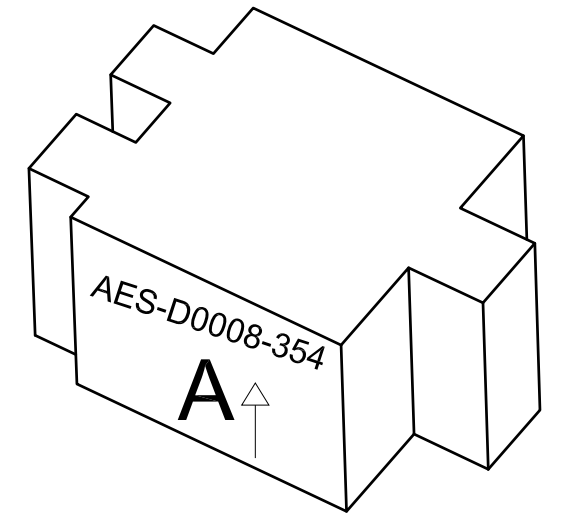
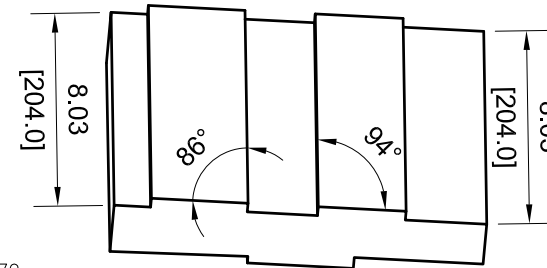

B5-179 A6-179

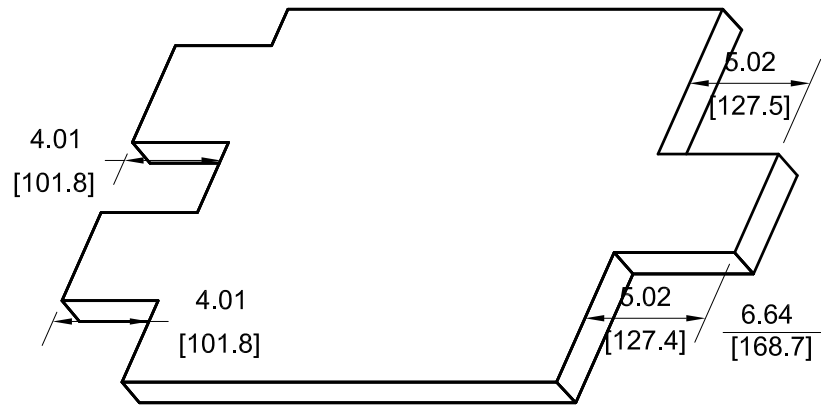

REAR VIEW RELATIVE TO VIEW D4-179

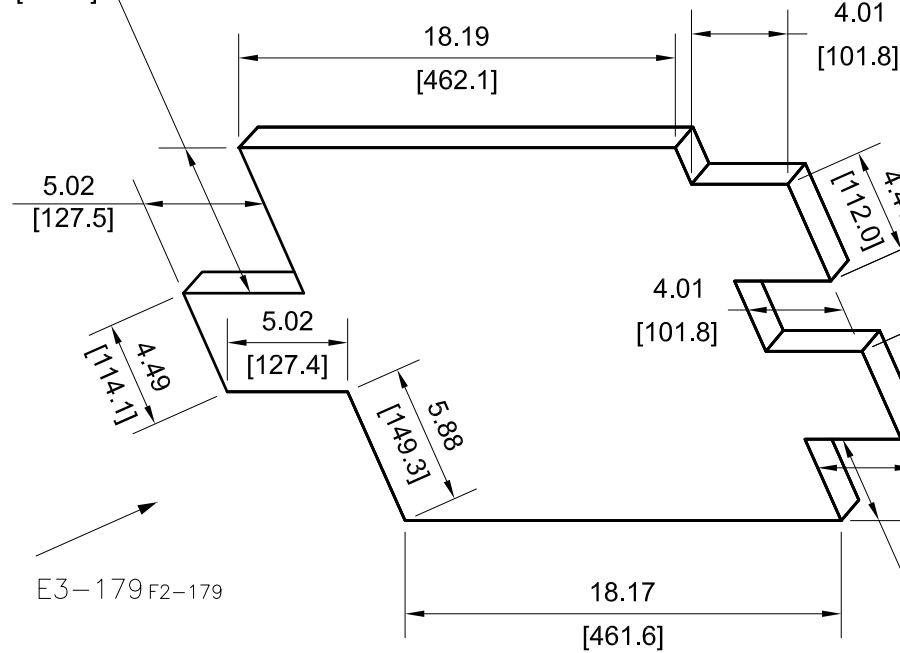

E3-179 F2-179

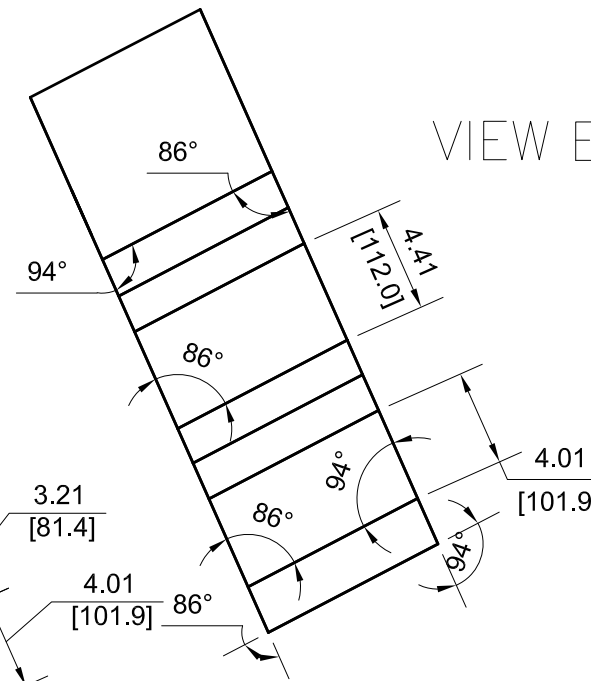

VIEW E5-179

E5-179 C6-179

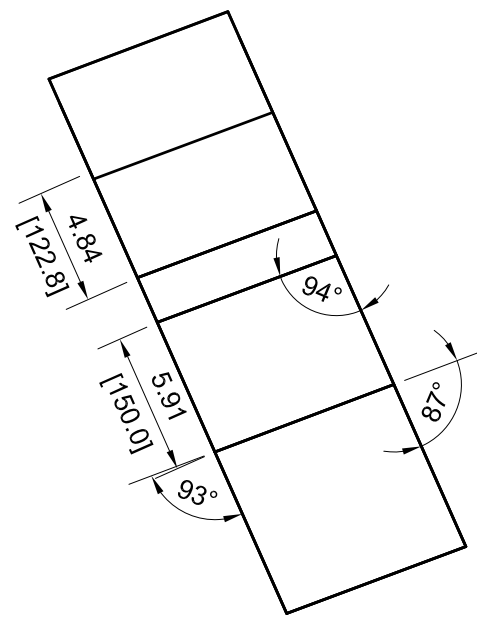

VIEW E3-179

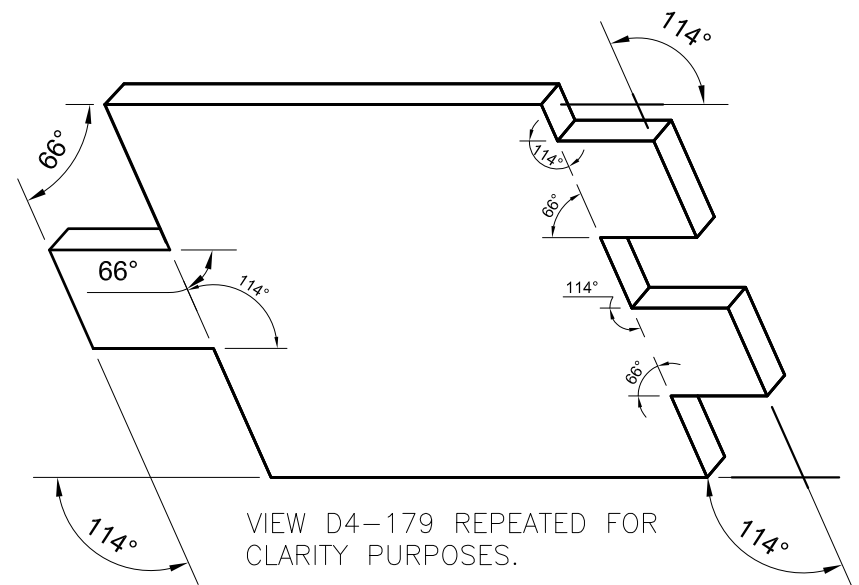
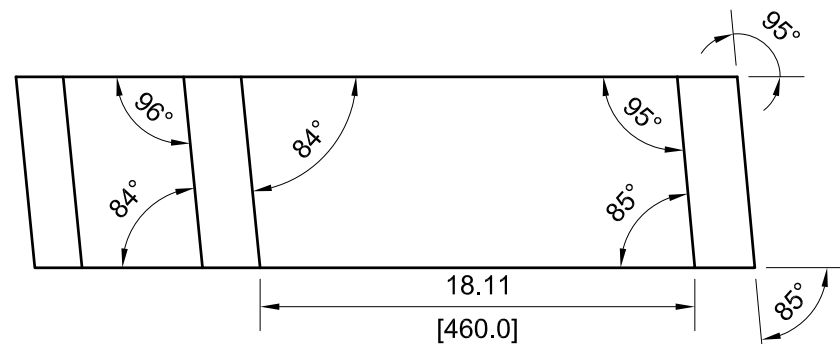

VIEW D4-179 REPEATED FOR CLARITY PURPOSES.



DRAWING NUMBER				
AES-D0008				
SIZE	SCALE	SHEET	OF	REVISION
A3	NONE	179	190	B

356

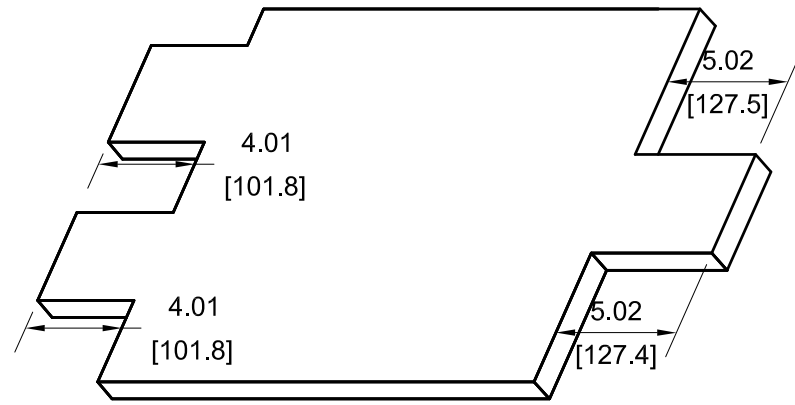

REAR VIEW RELATIVE TO VIEW D4-180

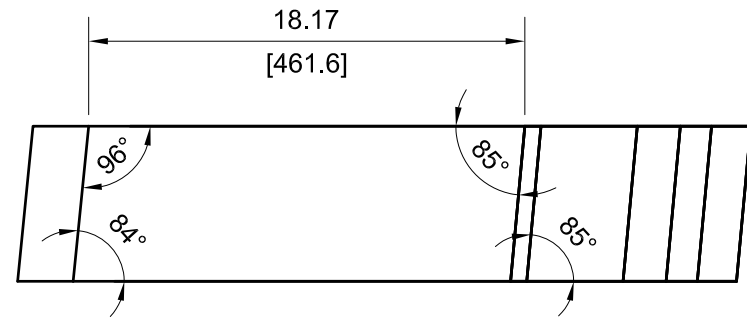

B5-180 A6-180

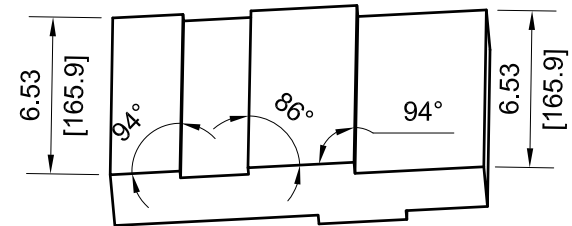

VIEW B5-180

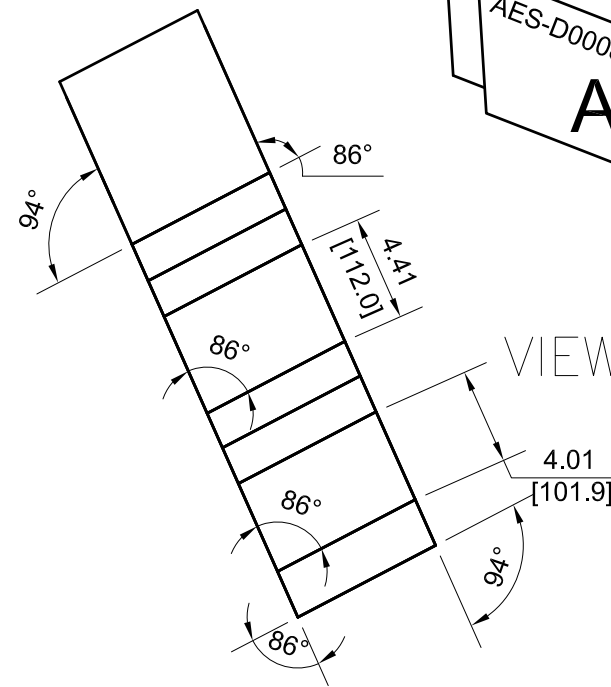
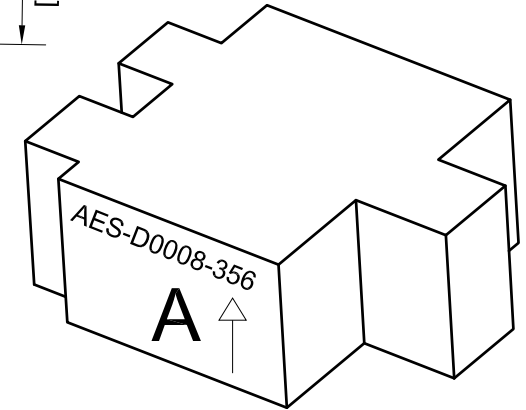

VIEW D6-180

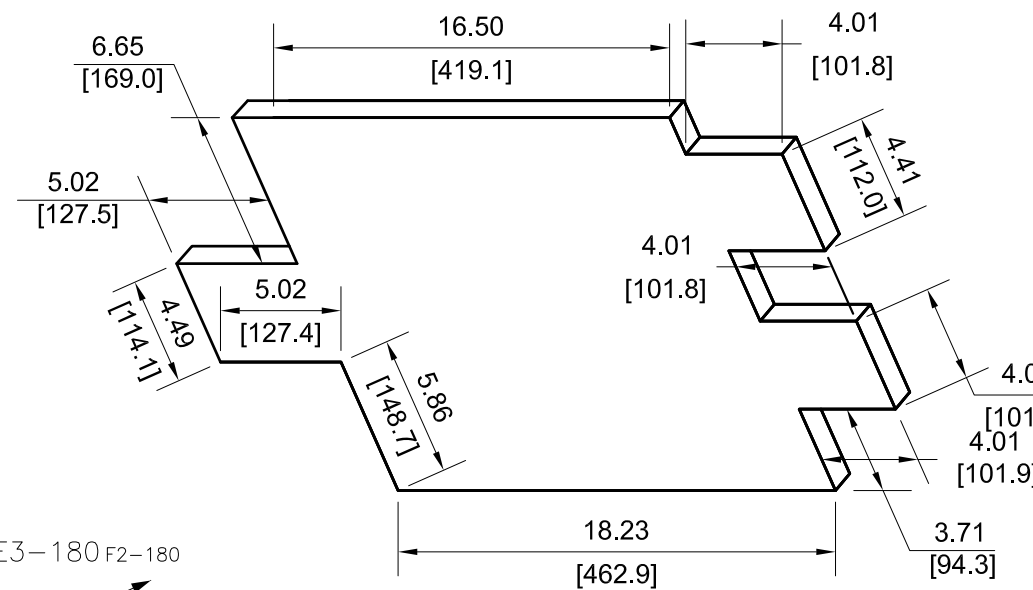

D6-180 C7-180

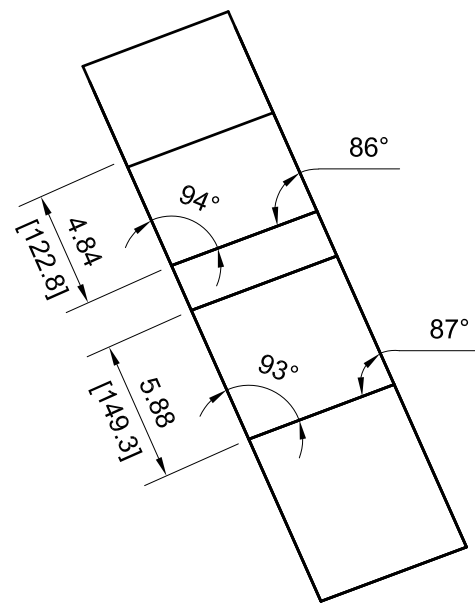

VIEW E3-180

E3-180 F2-180

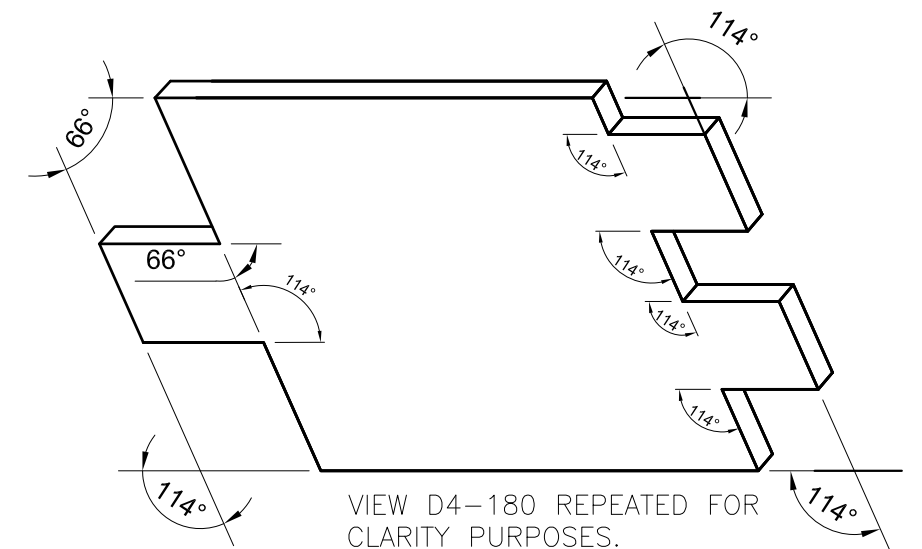
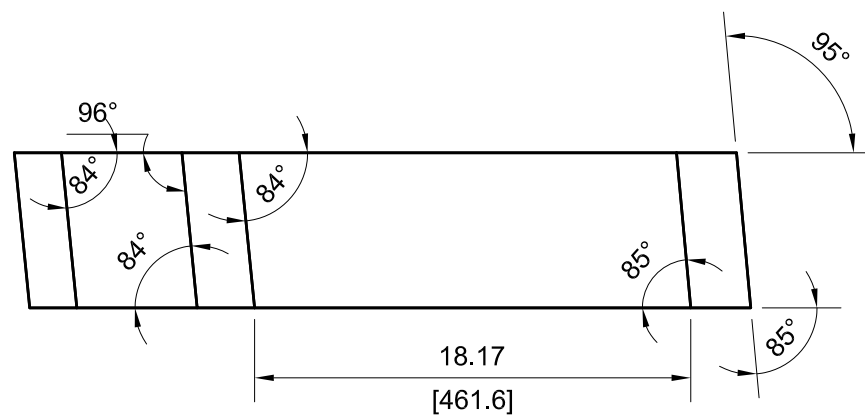

VIEW D4-180 REPEATED FOR CLARITY PURPOSES.



DRAWING NUMBER				
AES-D0008				
SIZE	SCALE	SHEET	OF	REVISION
A3	NONE	180	190	B

358

VIEW B4-181

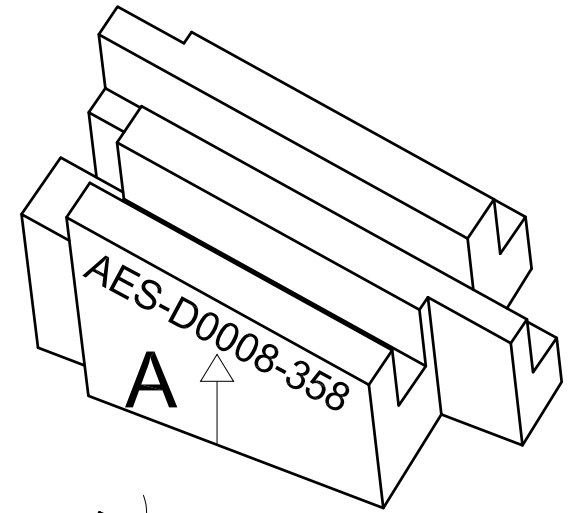
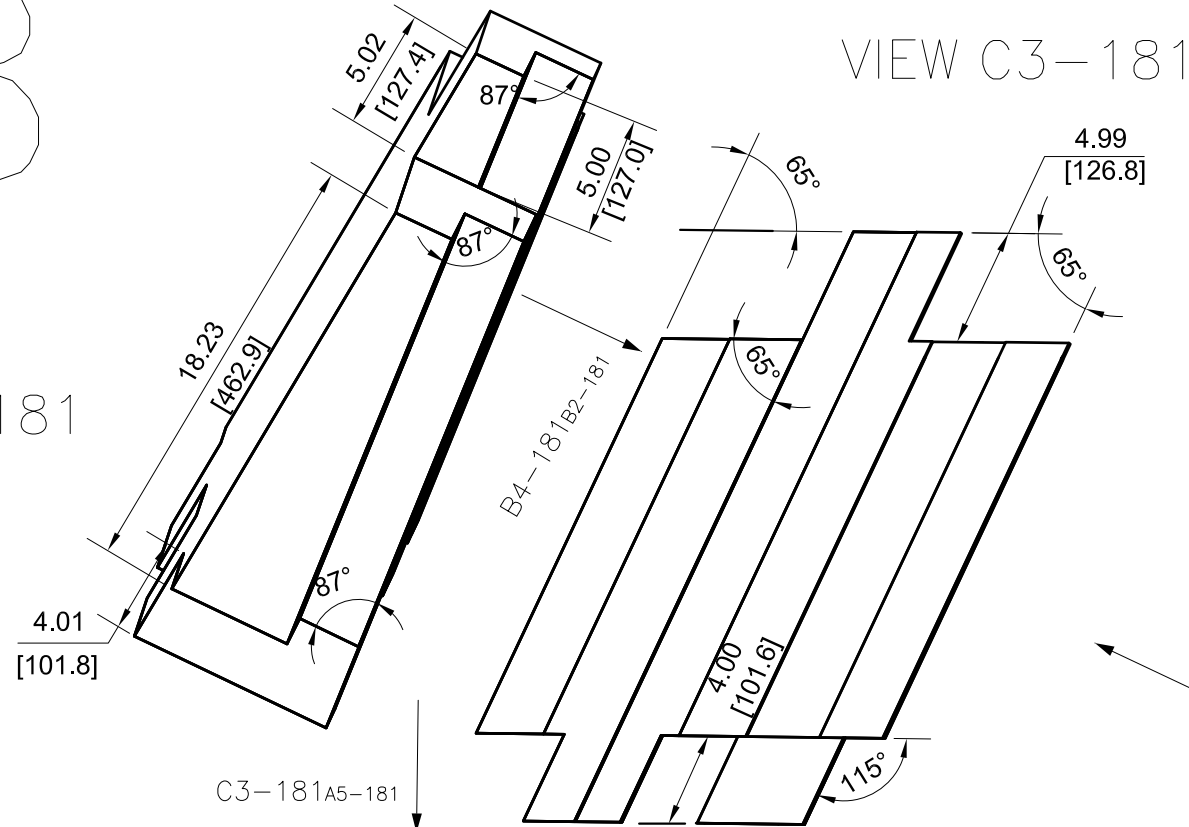

C3-181A5-181

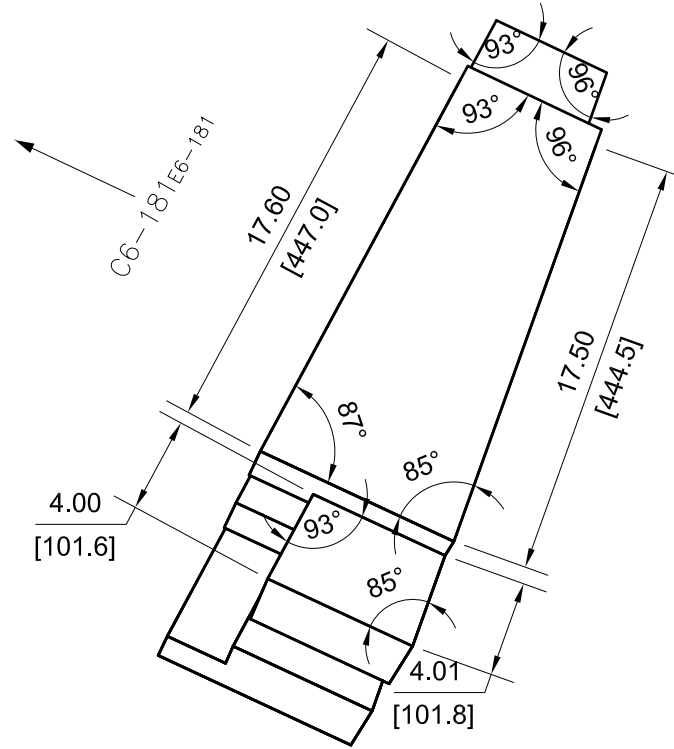

VIEW C6-181

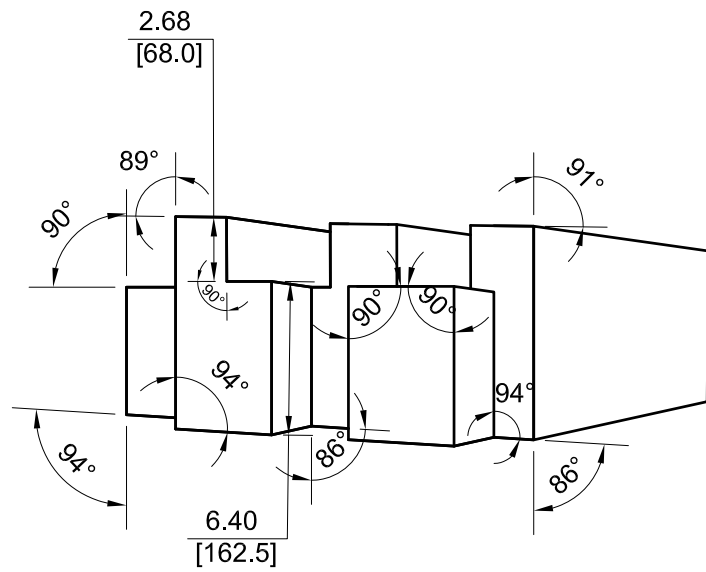

VIEW D4-181 REPEATED FOR CLARITY PURPOSES.

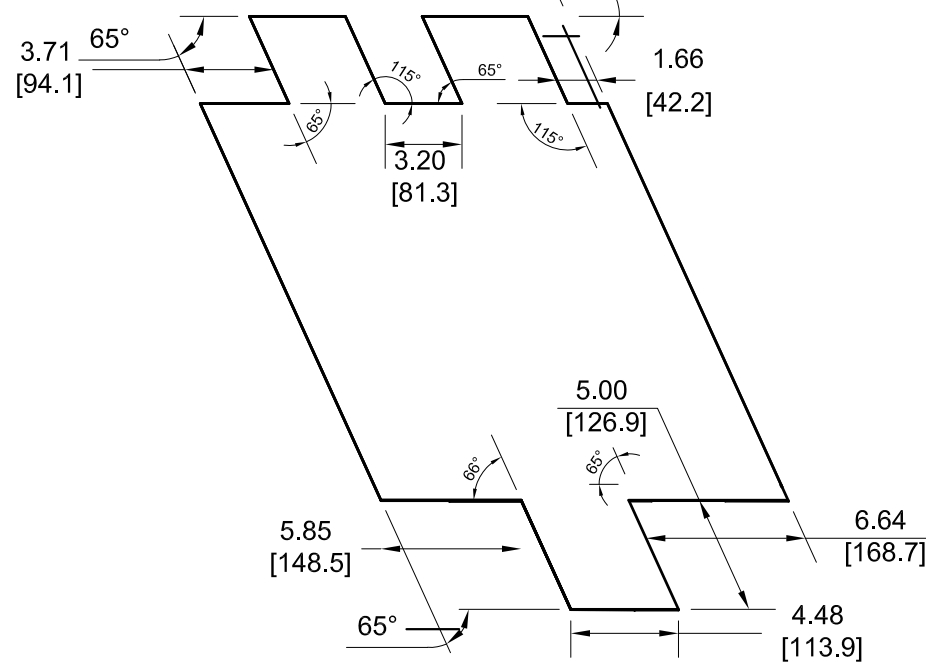

DRAWING NUMBER				
AES-D0008				
SIZE	SCALE	SHEET	OF	REVISION
A3	NONE	181	190	B

360

VIEW B5-182

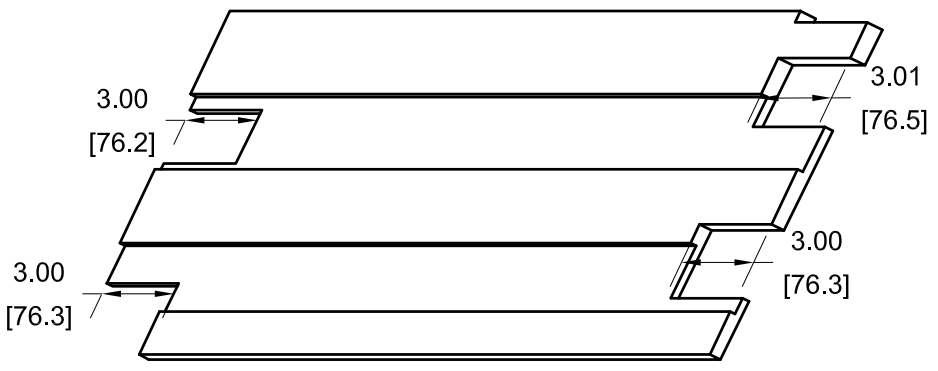
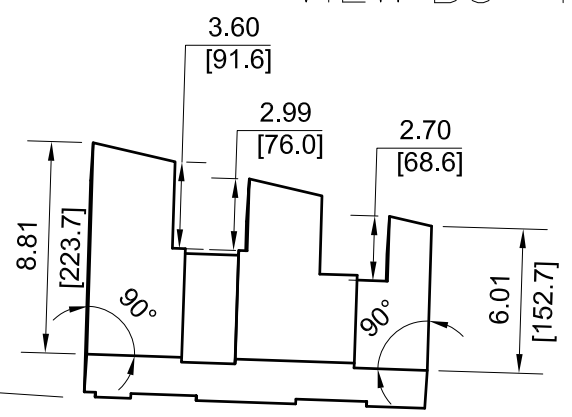
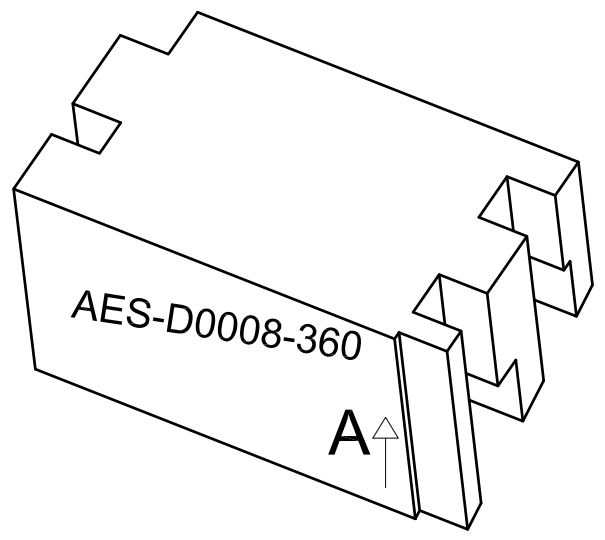

B5-182 A6-182

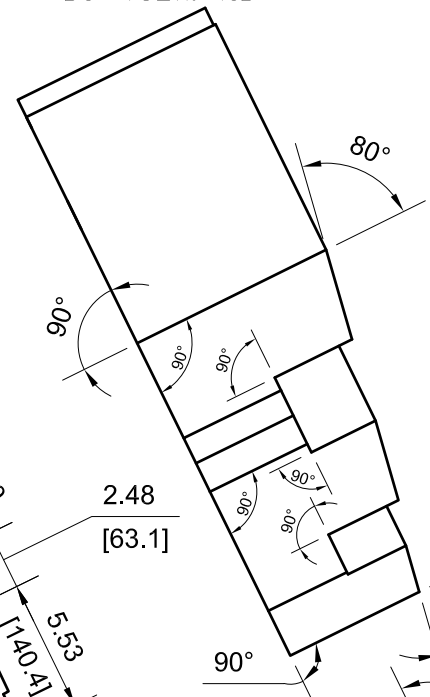

VIEW E5-182

REAR VIEW RELATIVE TO VIEW D4-182

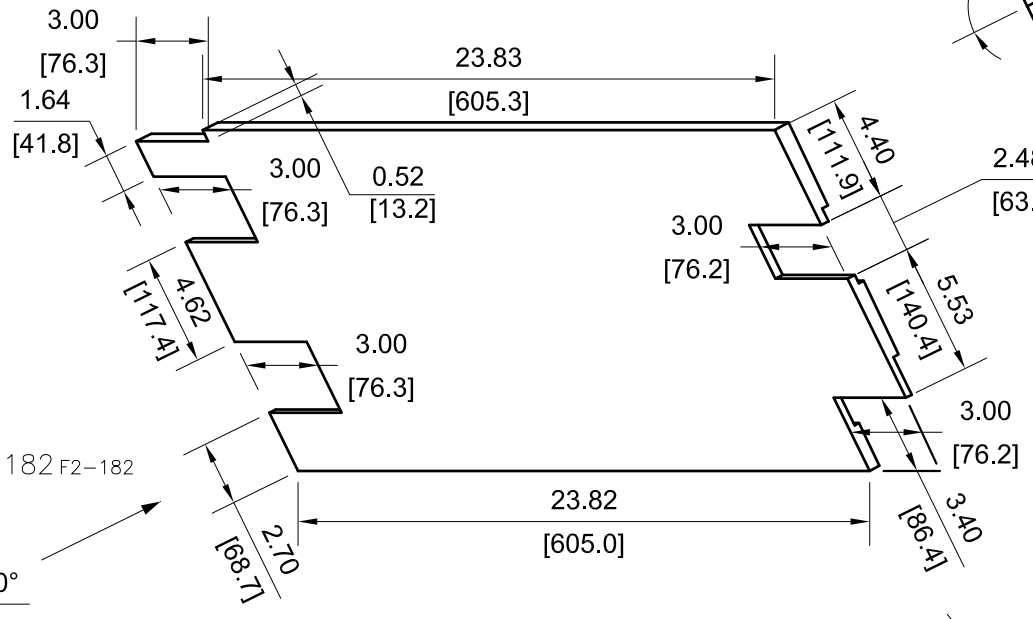

E2-182 F2-182

E5-182 D6-182

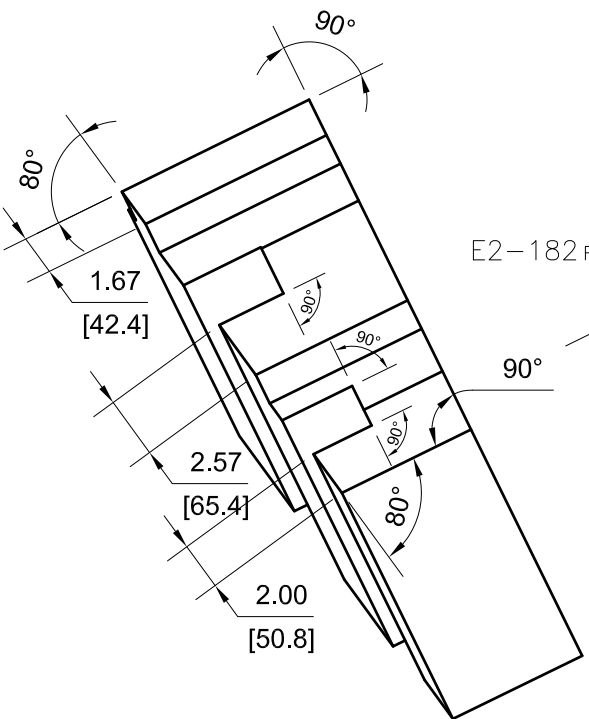

VIEW E2-182

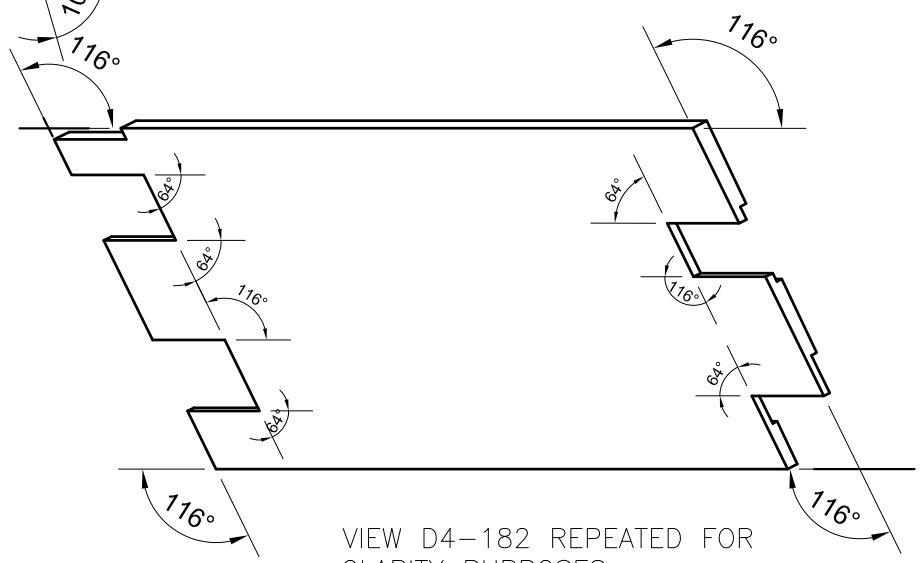
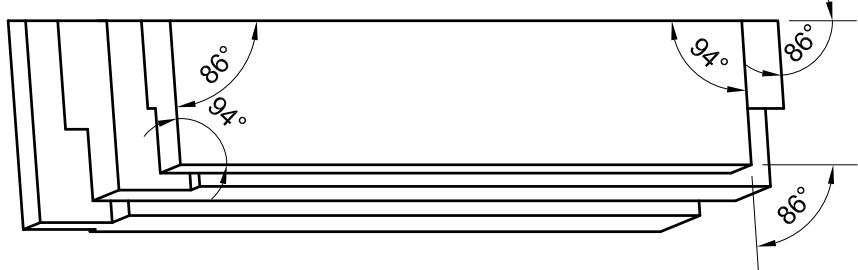

VIEW D4-182 REPEATED FOR CLARITY PURPOSES.



DRAWING NUMBER				
AES-D0008				
SIZE	SCALE	SHEET	OF	REVISION
A3	NONE	182	190	B

362

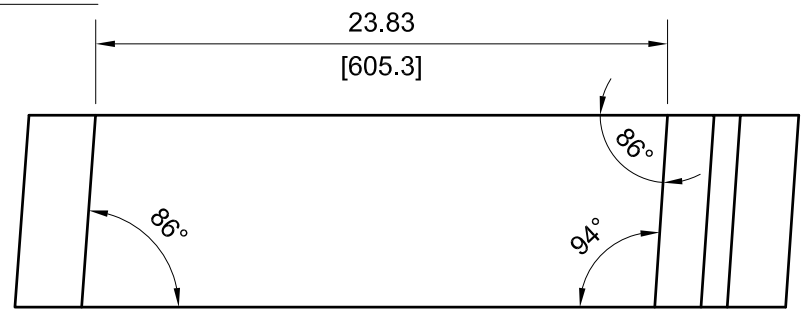

VIEW B5-183

B5-183 A6-183

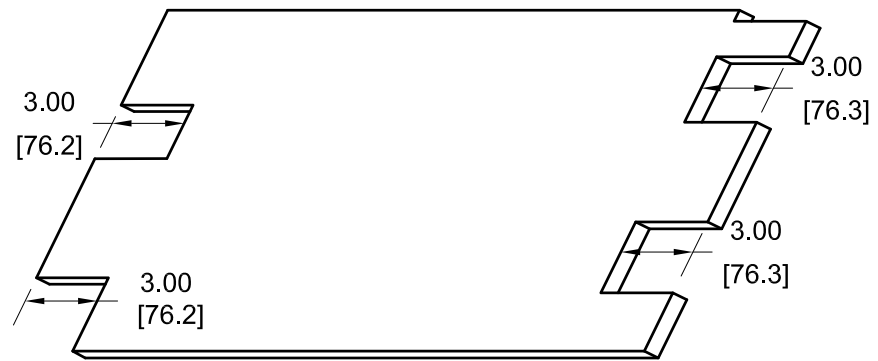
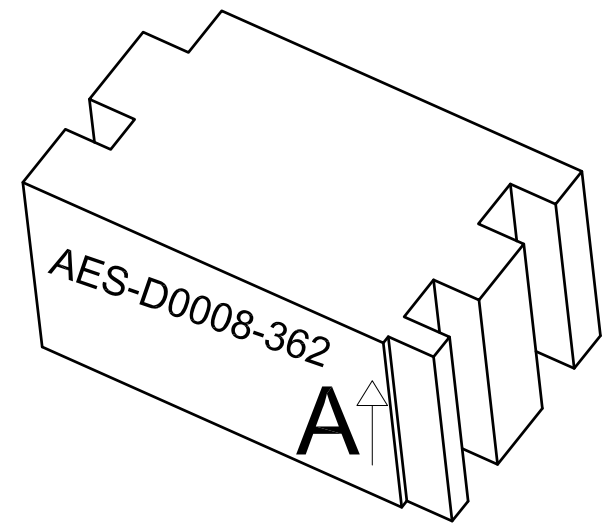
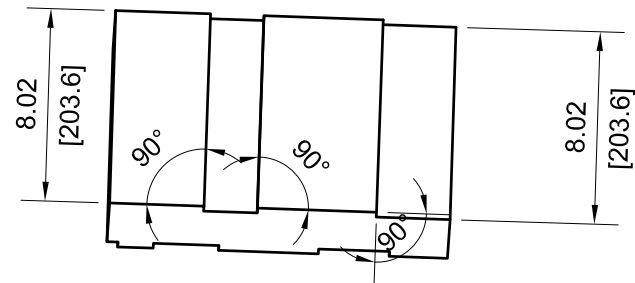

REAR VIEW RELATIVE TO VIEW E4-183

VIEW E5-183

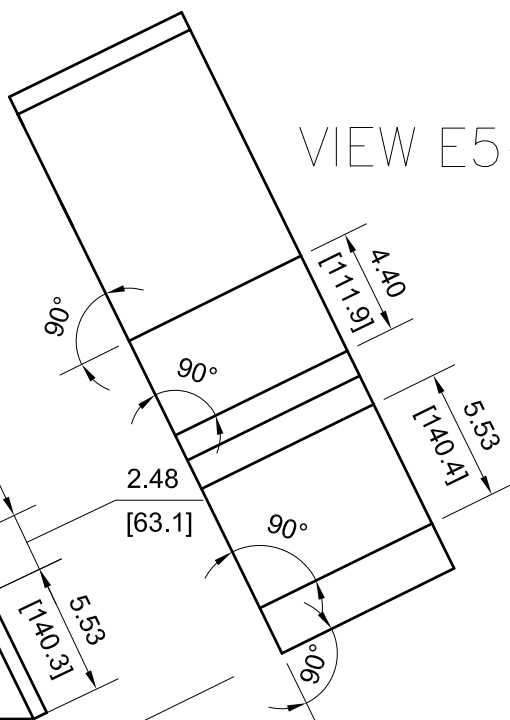

E5-183 C5-183

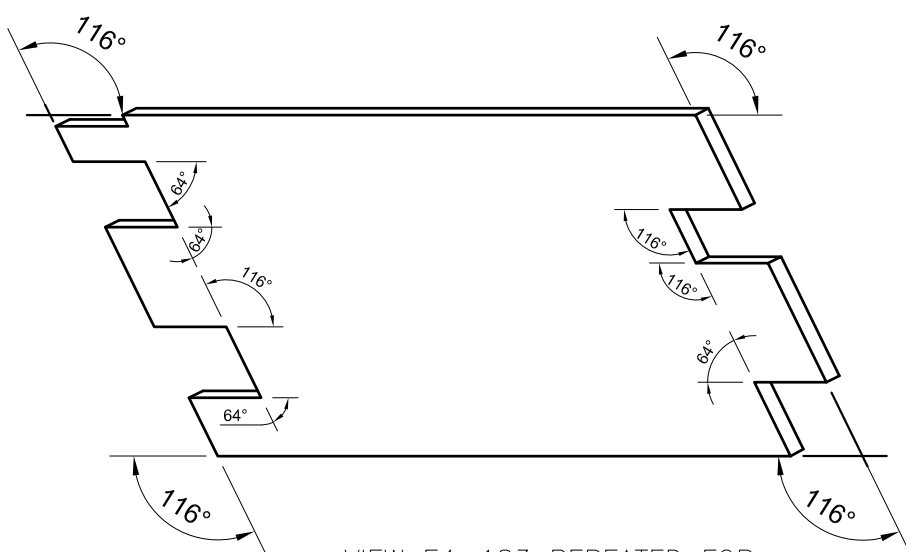

VIEW E4-183 REPEATED FOR CLARITY PURPOSES.

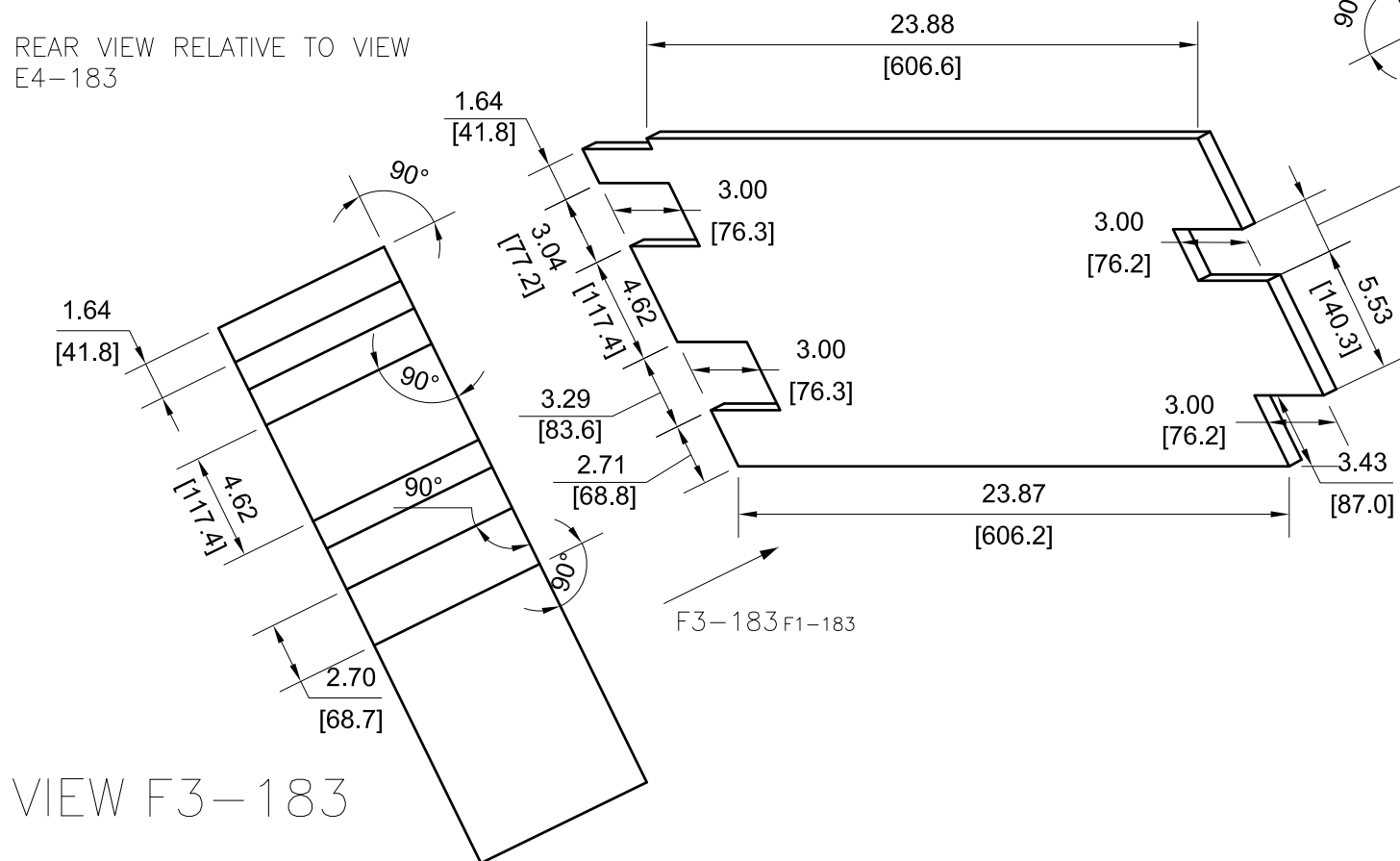

VIEW F3-183

F3-183 F1-183

	DRAWING NUMBER				AES-D0008
	SIZE	SCALE	SHEET	OF	REVISION
A3	NONE	183	190	B	

364

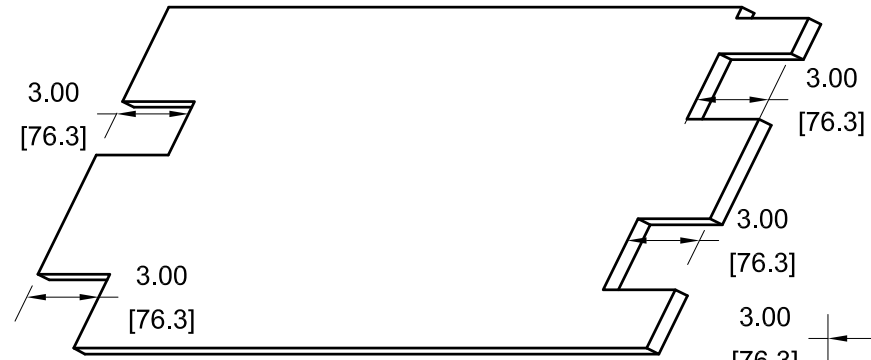

REAR VIEW RELATIVE TO VIEW D4-184

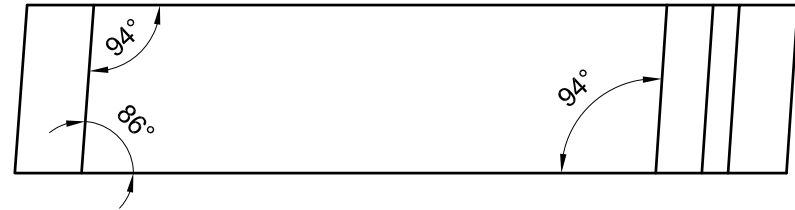

A5-184 A6-184 VIEW A5-184

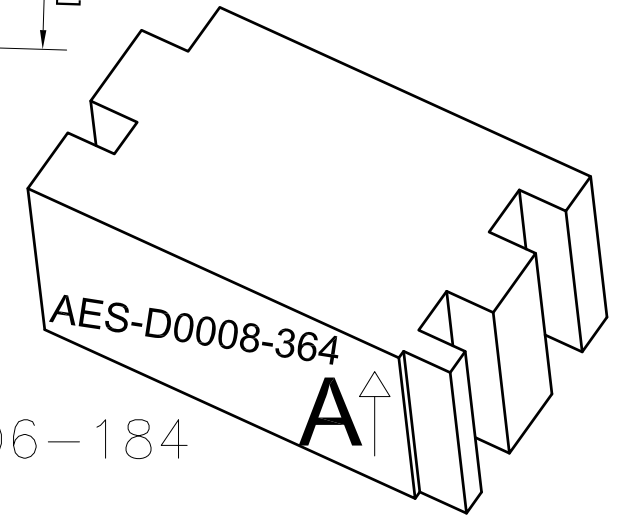
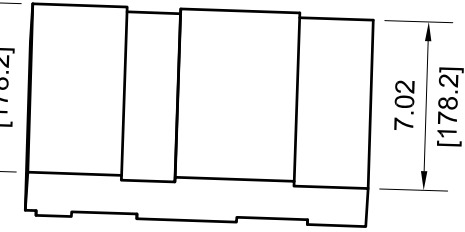

VIEW D6-184

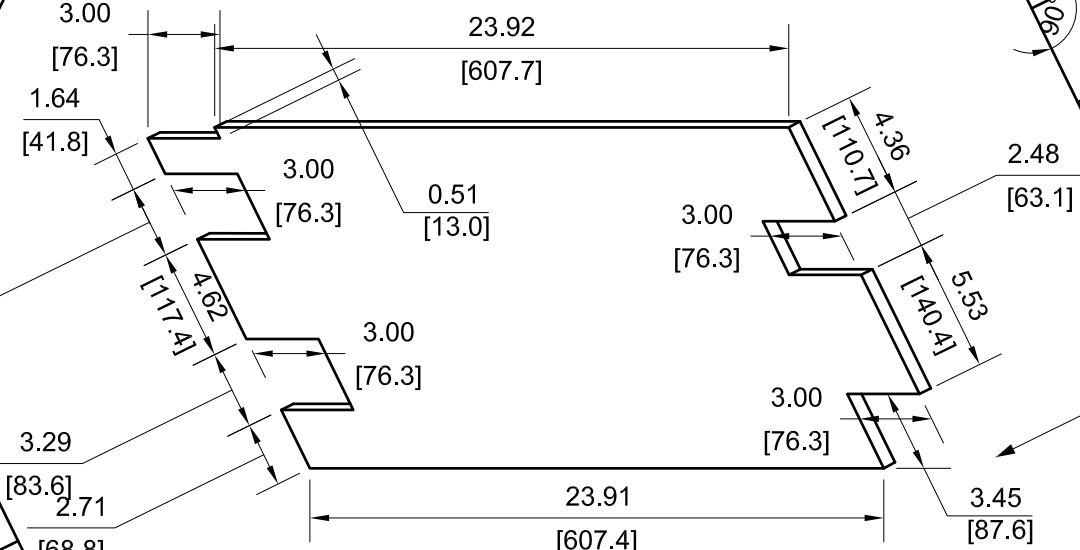

D6-184 C6-184

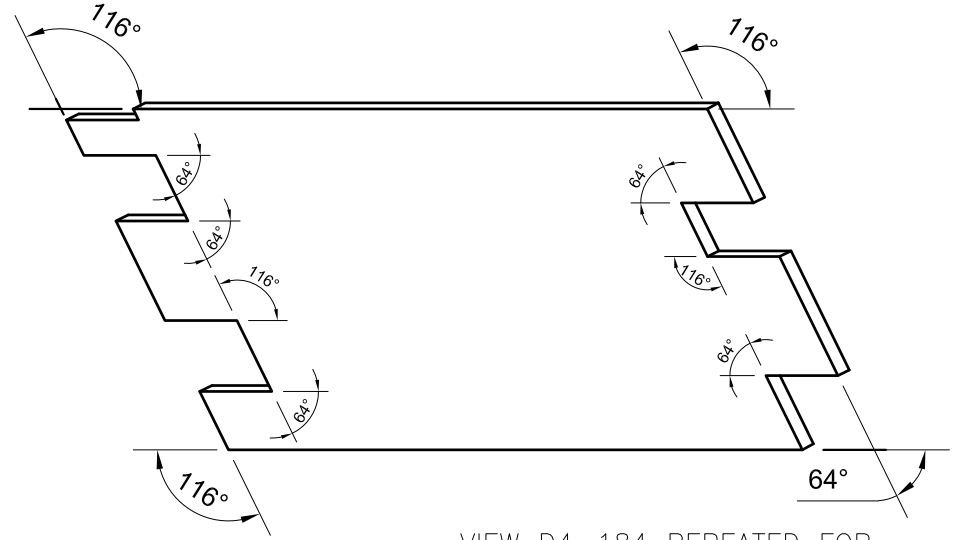

VIEW D4-184 REPEATED FOR CLARITY PURPOSES.

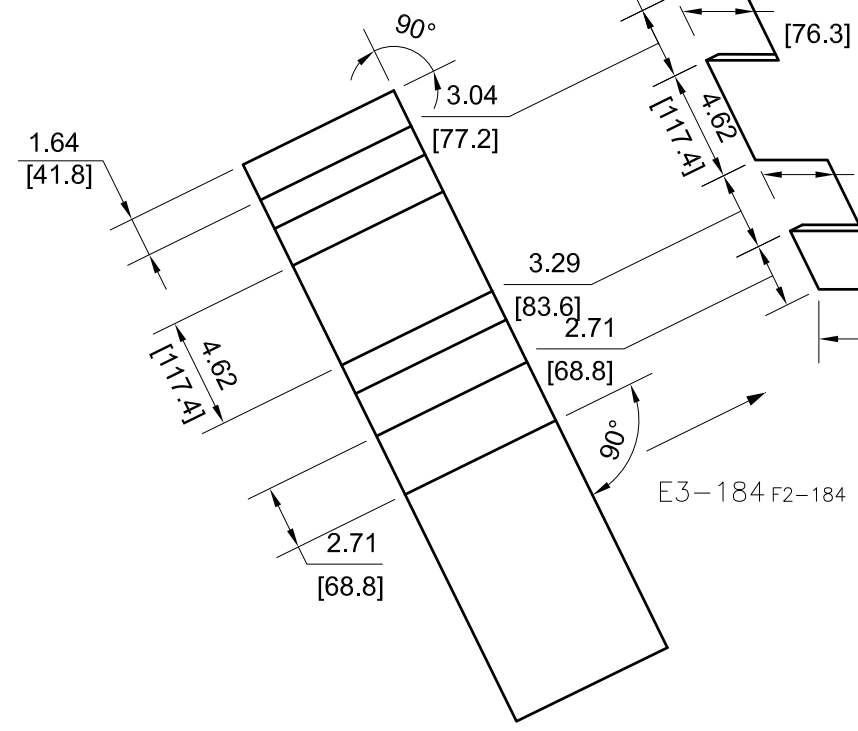

VIEW E3-184

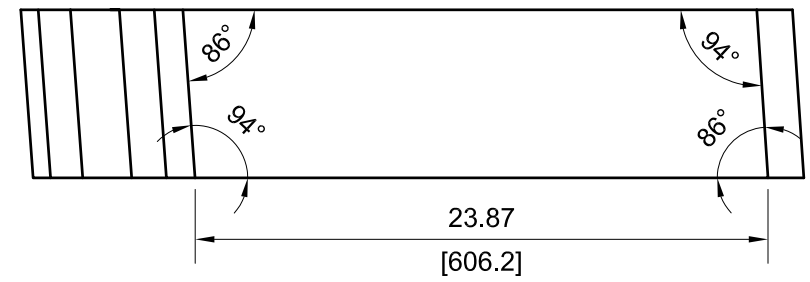

23.87 [606.2]



DRAWING NUMBER				
AES-D0008				
SIZE	SCALE	SHEET	OF	REVISION
A3	NONE	184	190	B

3666

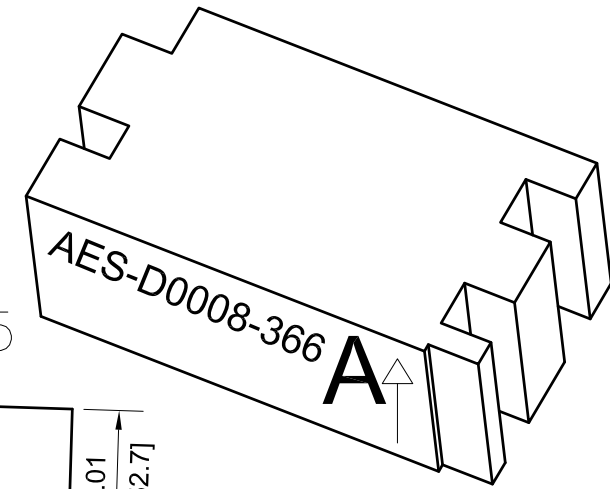

VIEW 1B5-185

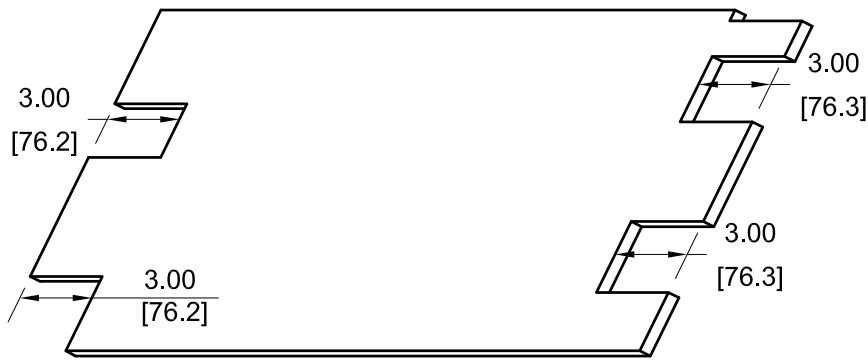
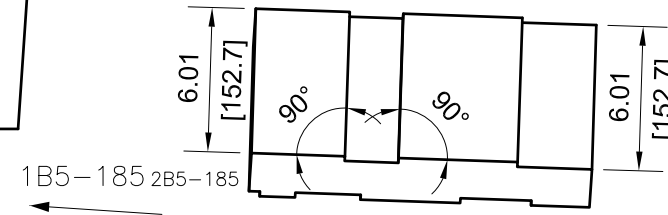
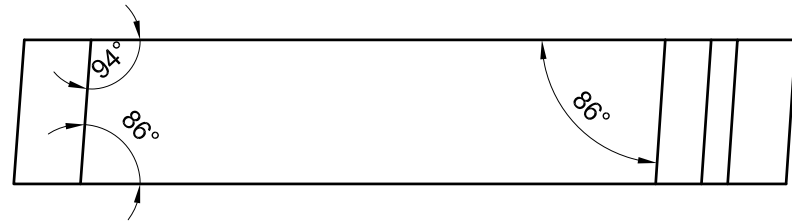

VIEW E5-185

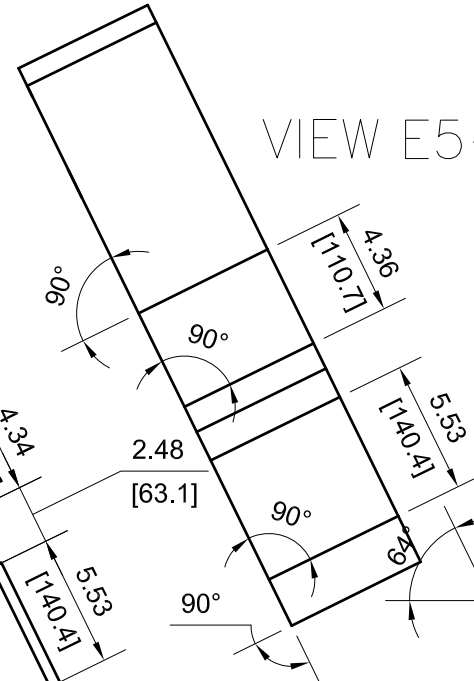

REAR VIEW RELATIVE TO VIEW D4-185

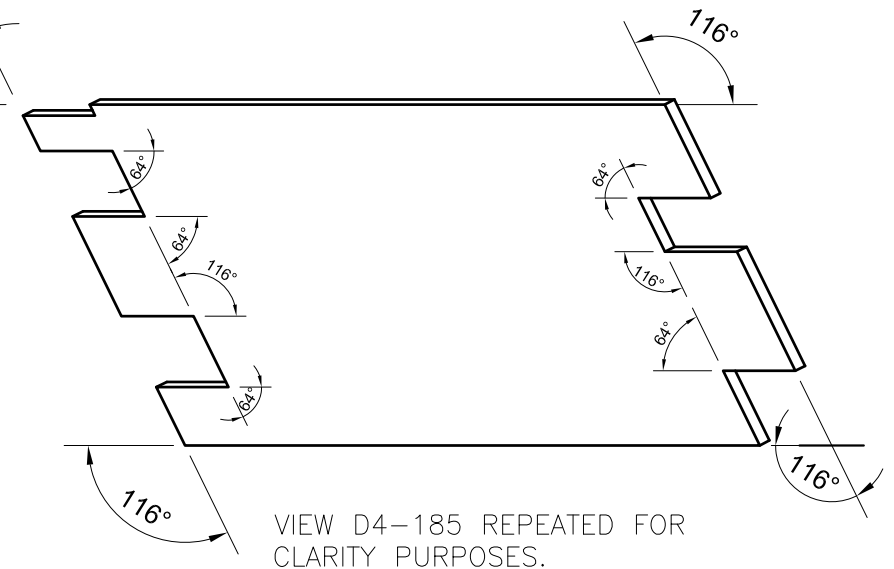
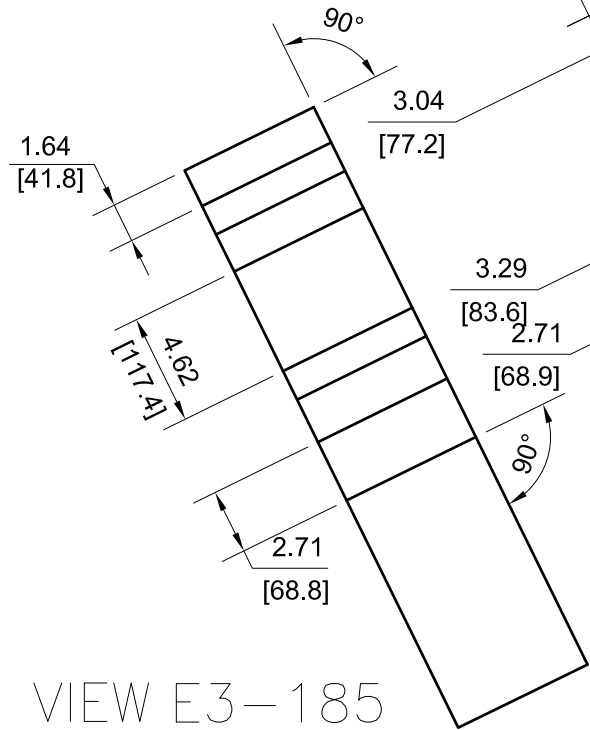
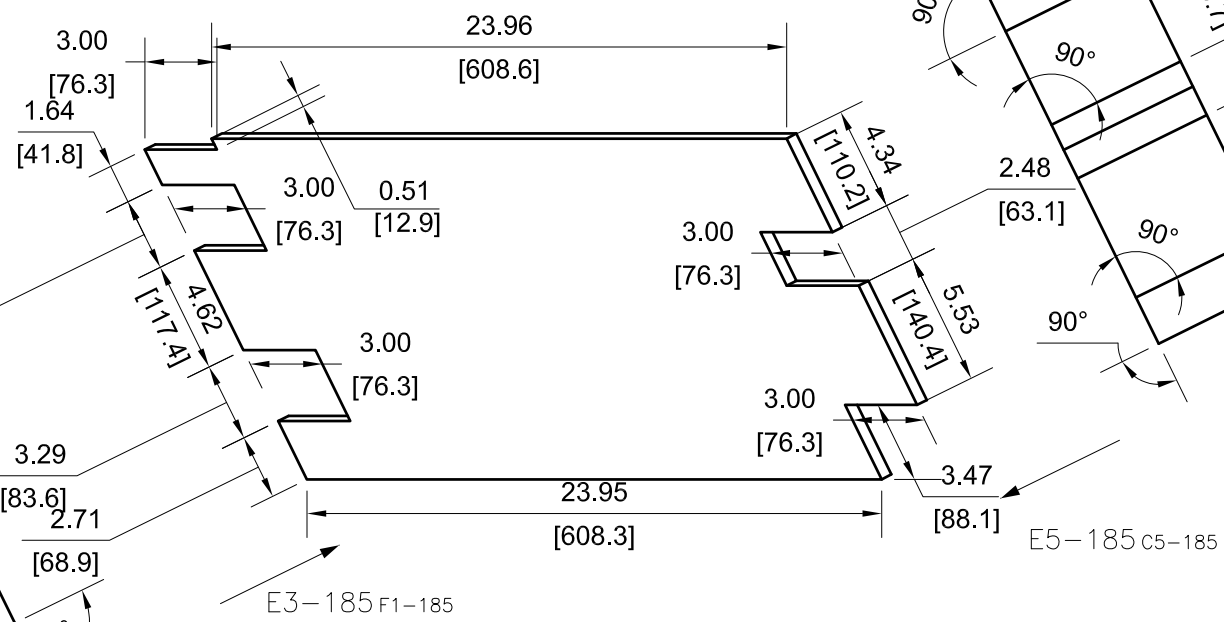

VIEW D4-185 REPEATED FOR CLARITY PURPOSES.



DRAWING NUMBER				
AES-D0008				
SIZE	SCALE	SHEET	OF	REVISION
A3	NONE	185	190	B

368

VIEW B5-186

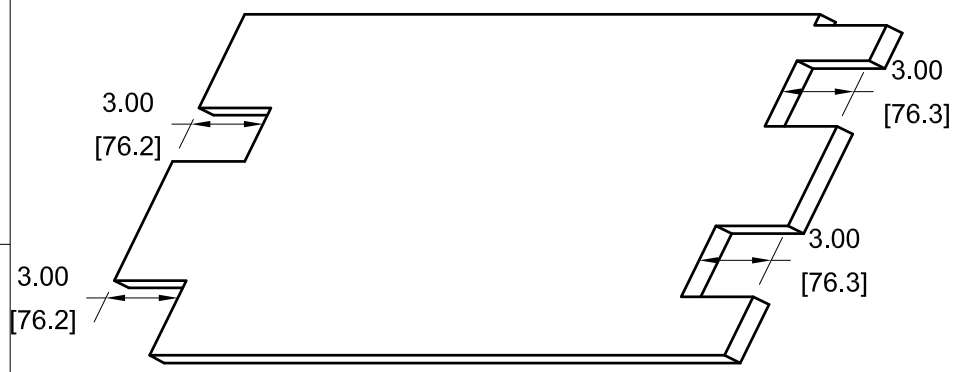
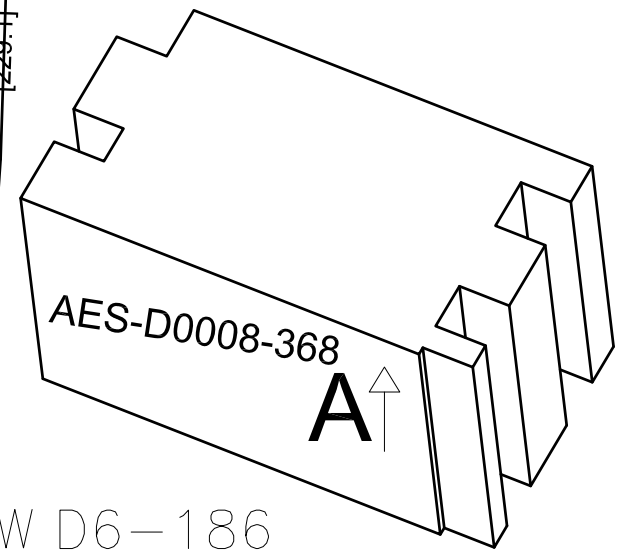
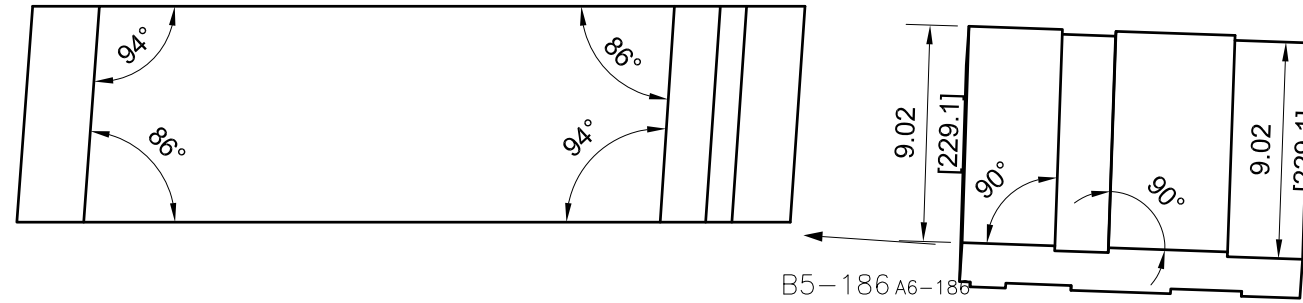

REAR VIEW RELATIVE TO VIEW D4-186

VIEW D6-186

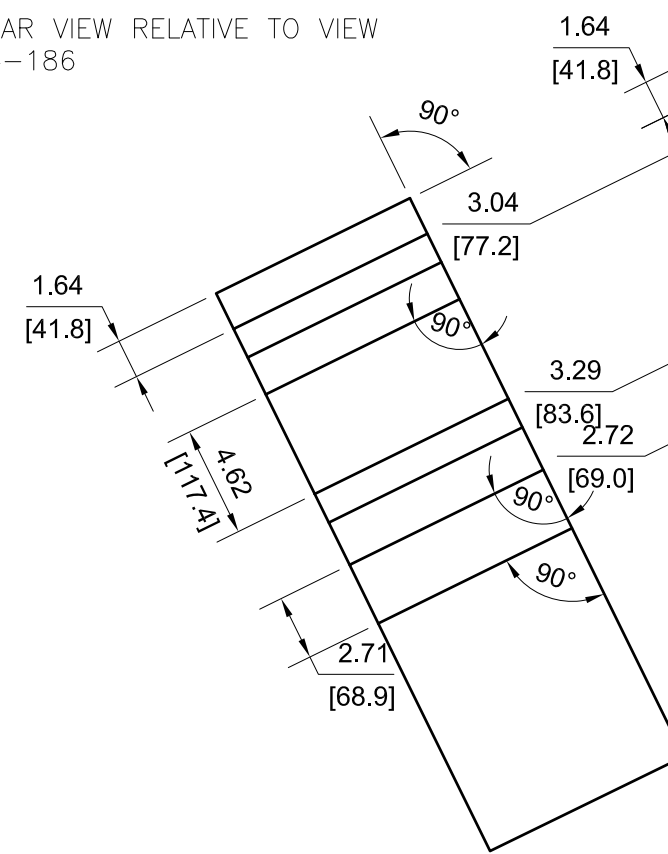
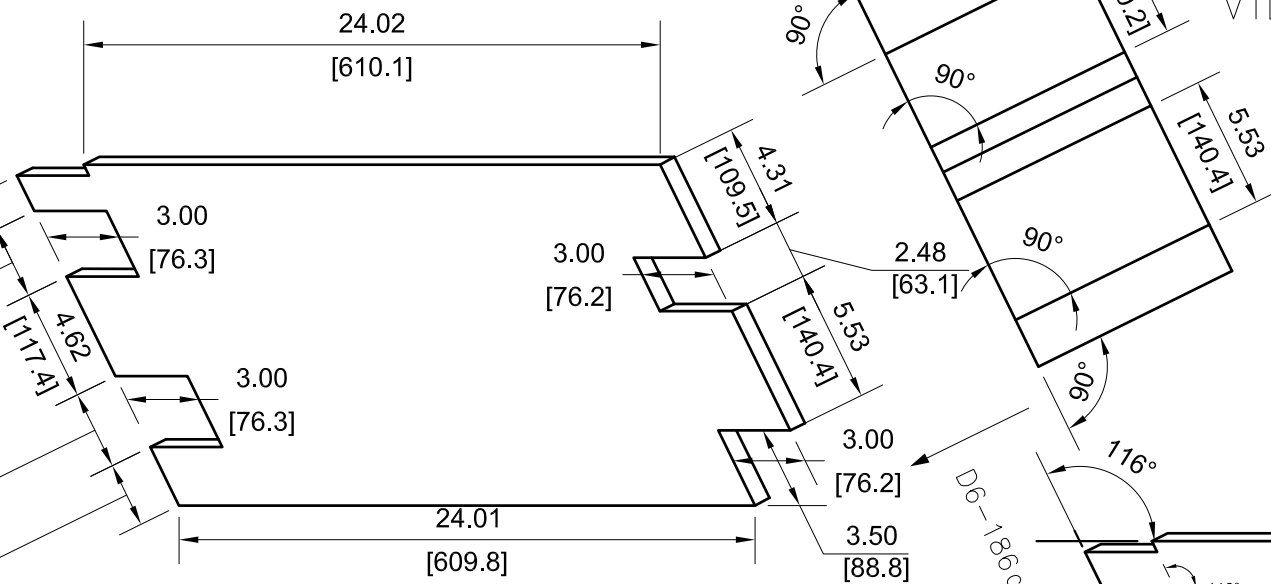

VIEW E3-186

E3-186 F2-186

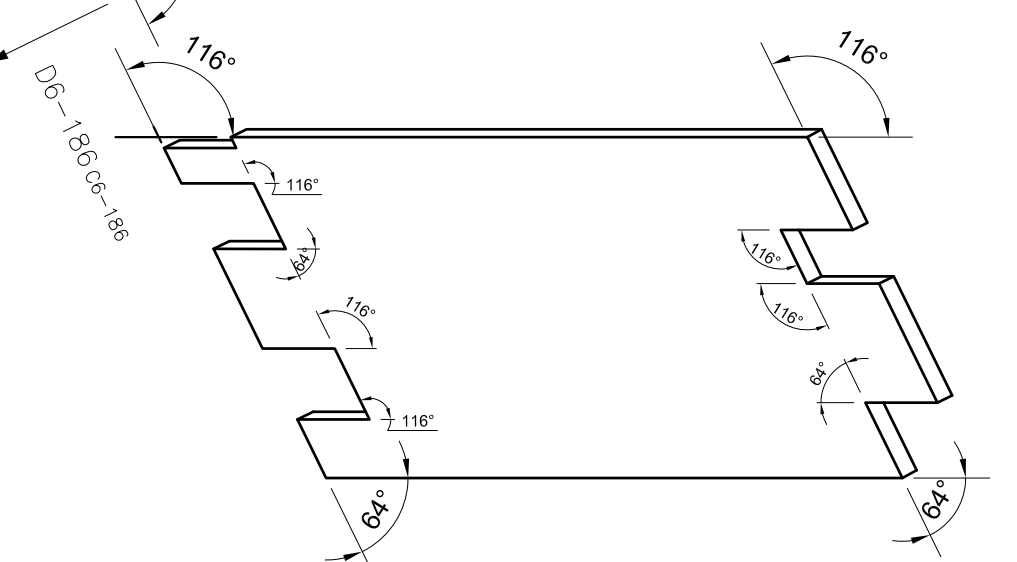
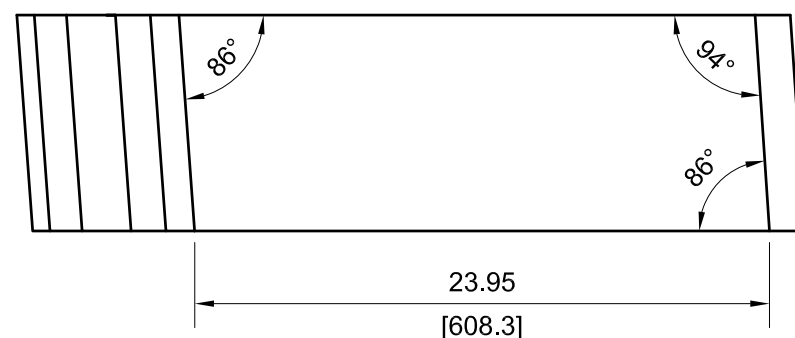

VIEW D4-186 REPEATED FOR CLARITY PURPOSES.



DRAWING NUMBER				
AES-D0008				
SIZE	SCALE	SHEET	OF	REVISION
A3	NONE	186	190	B

370

VIEW C4-187

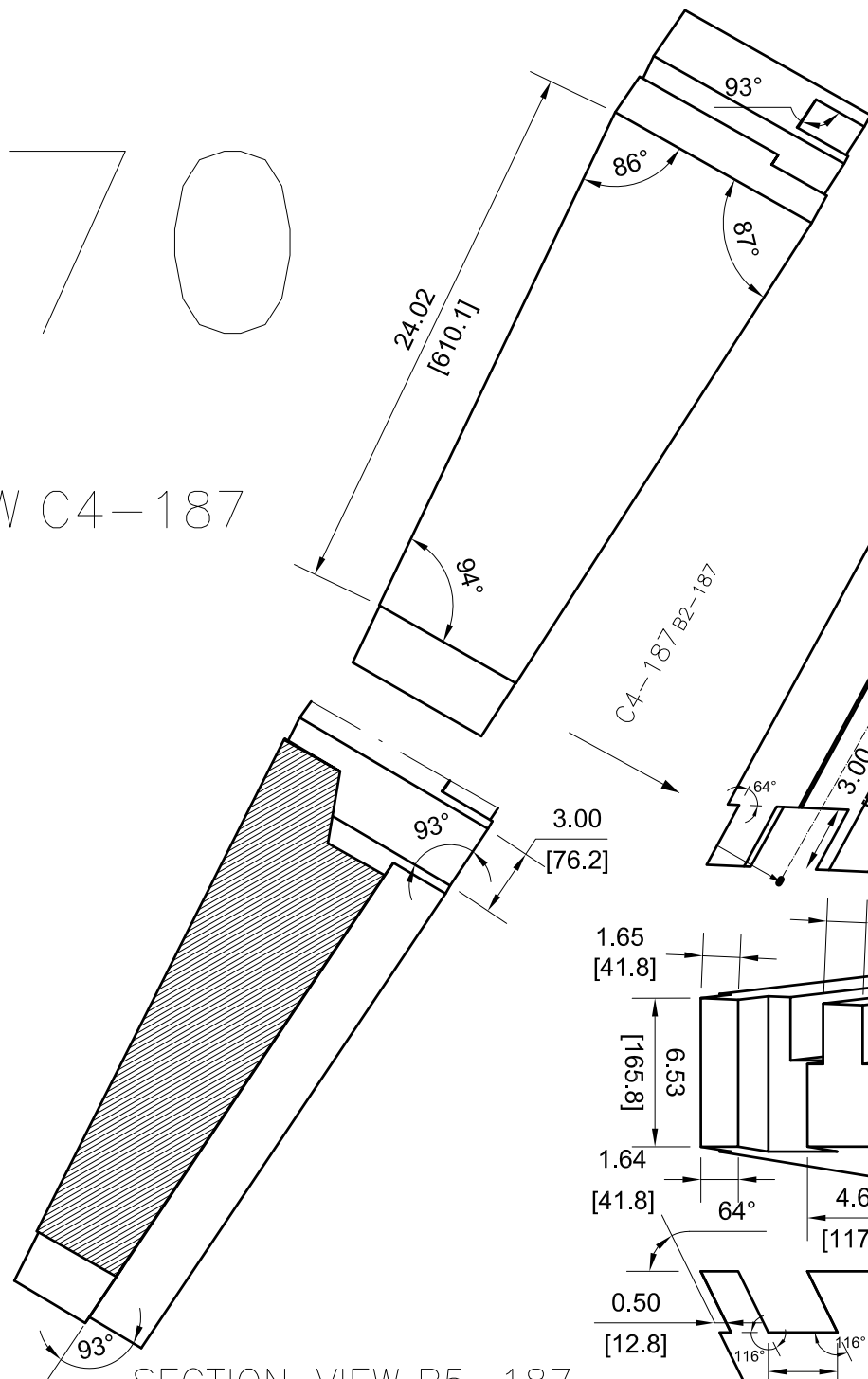

VIEW C5-187

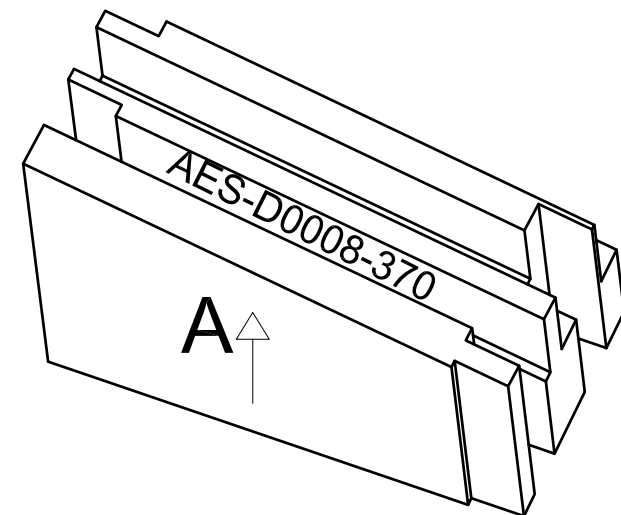
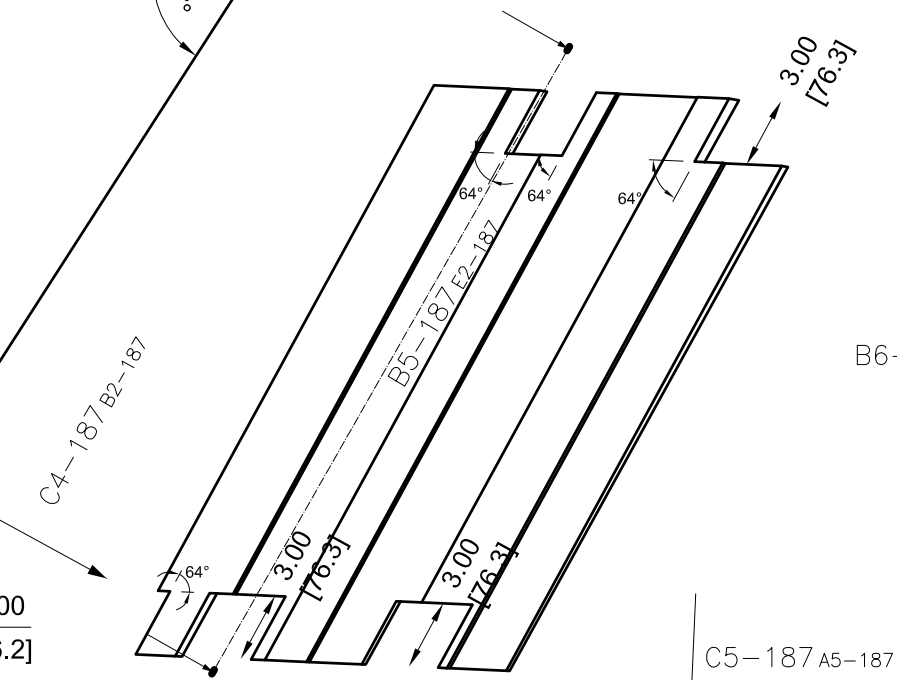

B6-187 D6-187

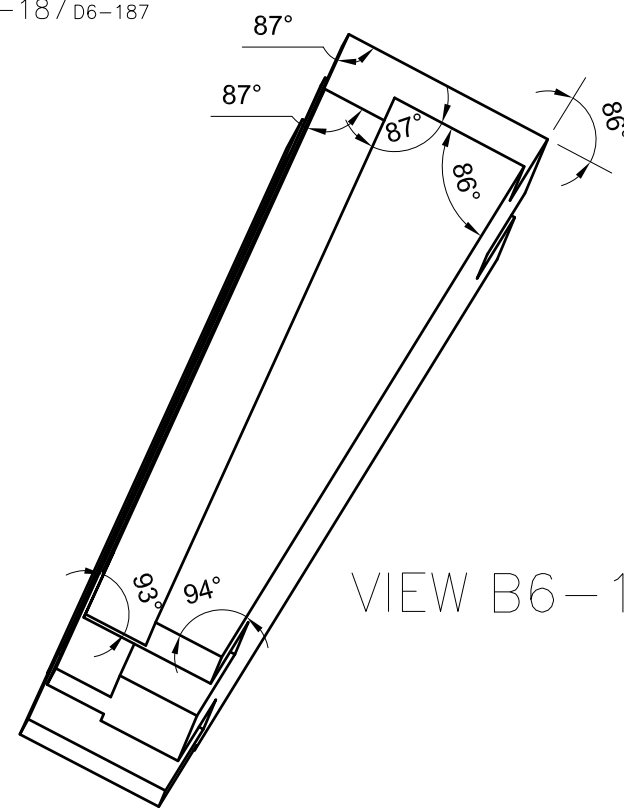

VIEW B6-187

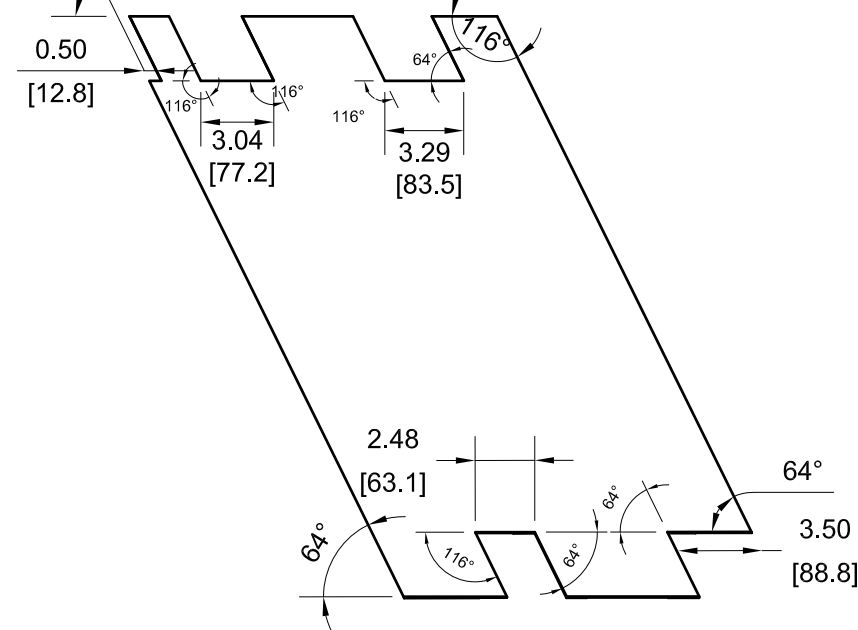
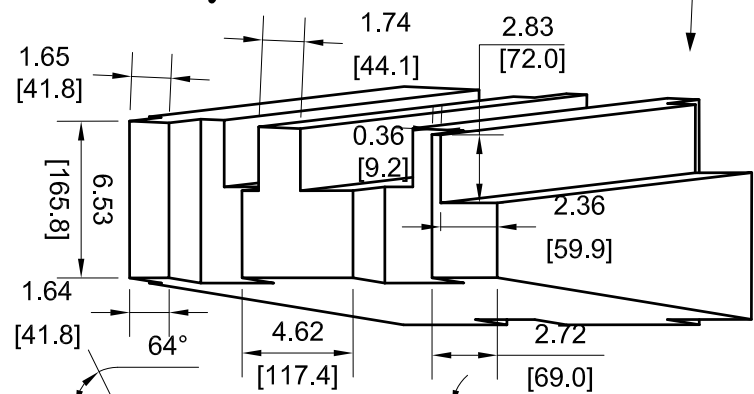

SECTION VIEW B5-187

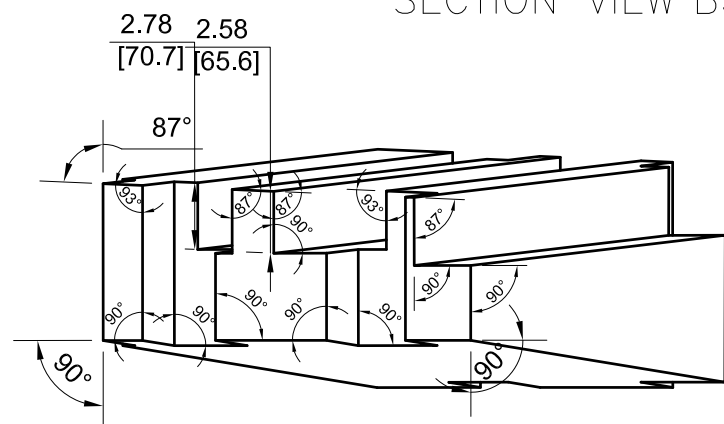

VIEW D4-187 REPEATED FOR CLARITY PURPOSES.



DRAWING NUMBER				
AES-D0008				
SIZE	SCALE	SHEET	OF	REVISION
A3	NONE	187	190	B

372

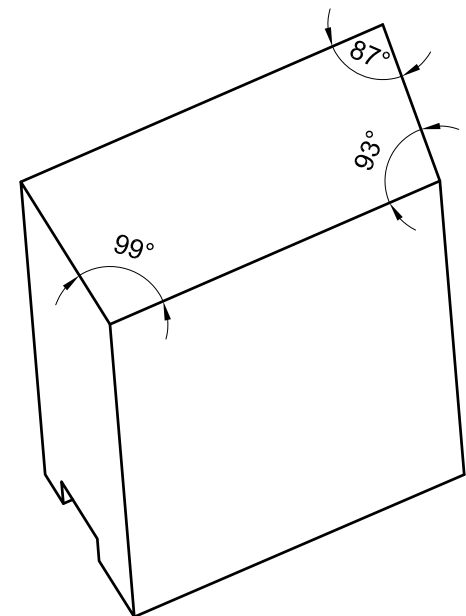

C2-188 D1-188

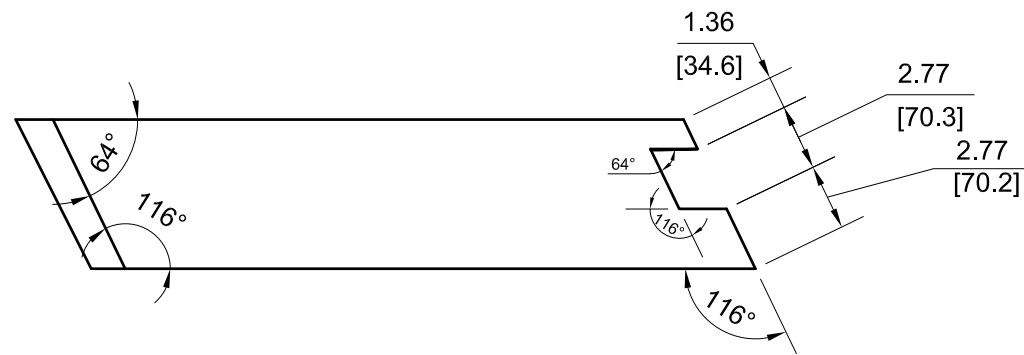

VIEW D5-188

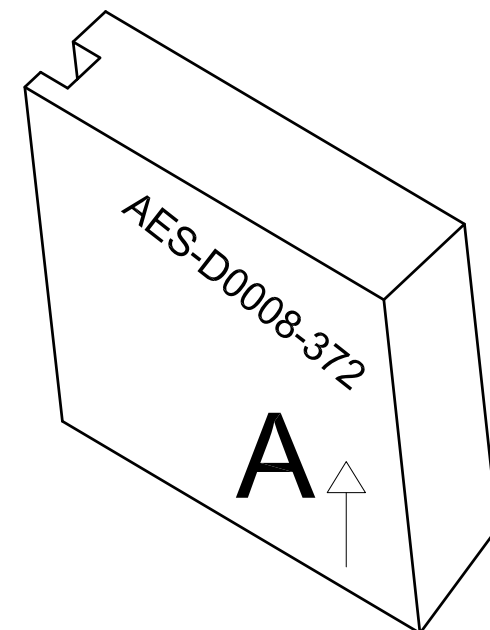
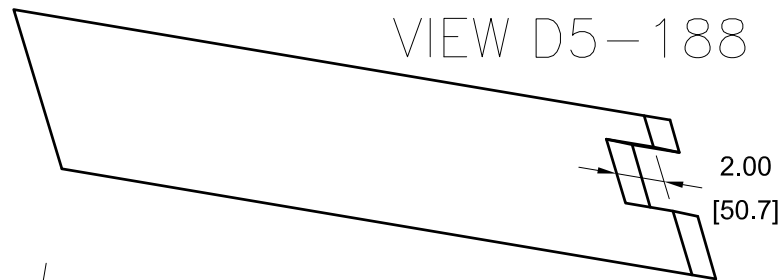

VIEW C2-188

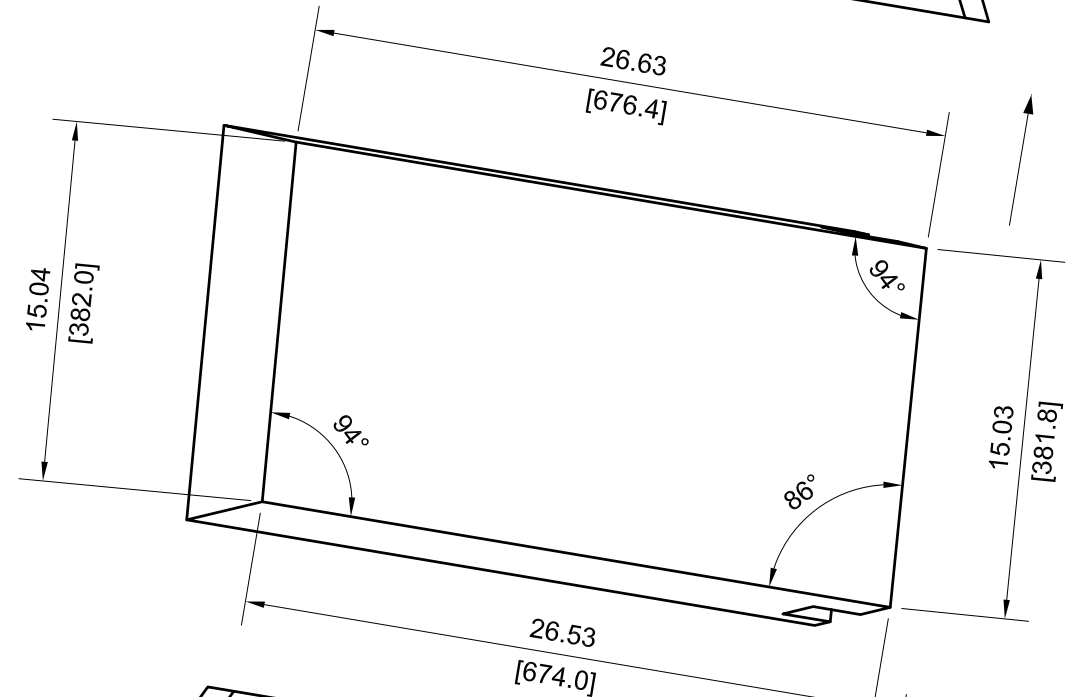

D5-188 C4-188

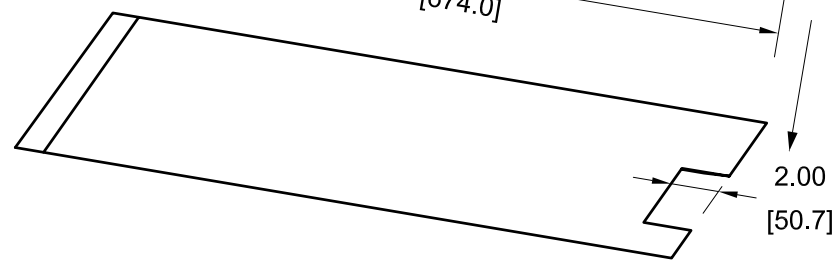

F5-188 F3-188

VIEW F5-188



DRAWING NUMBER					AES-D0008	
SIZE	SCALE	SHEET	OF	REVISION		
A3	NONE	188	190	B		

— 374

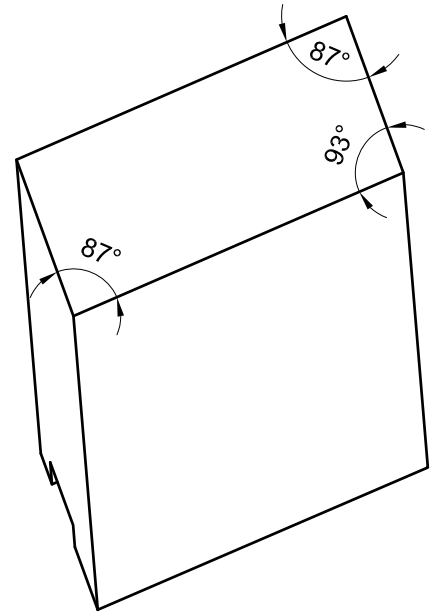

VIEW D2-189

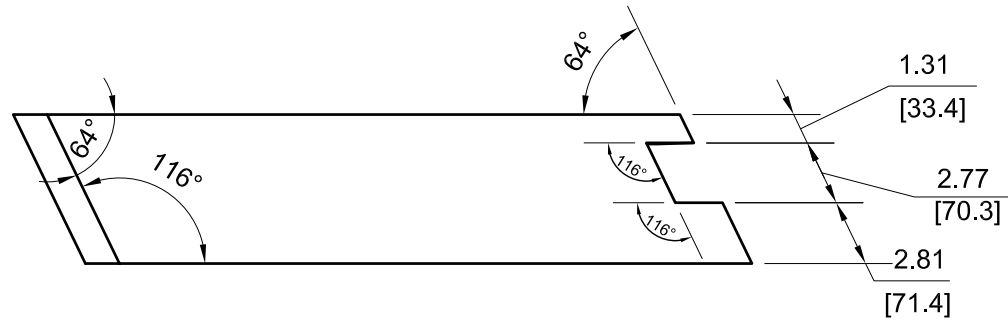

C3-189 D2-189

VIEW D5-189

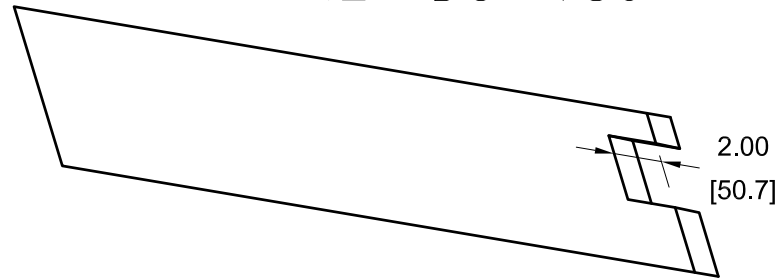

D5-189 C4-189

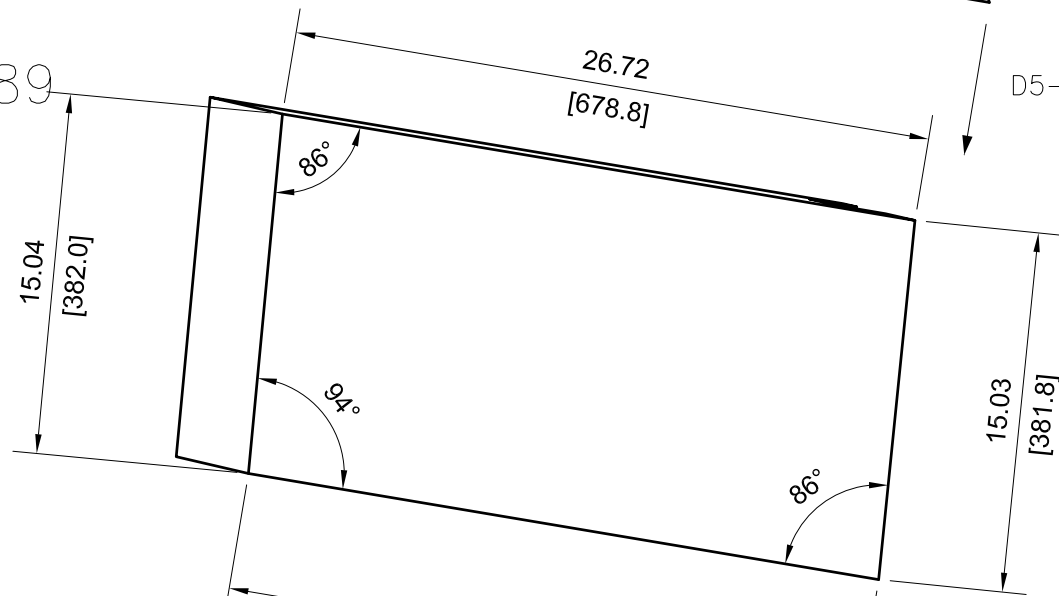

1F5-189 2F5-189

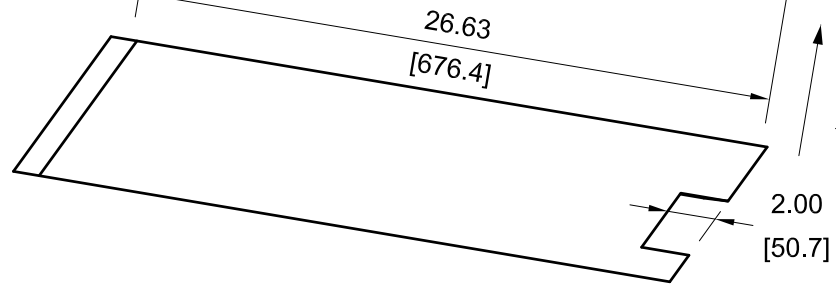

VIEW 1F5-189

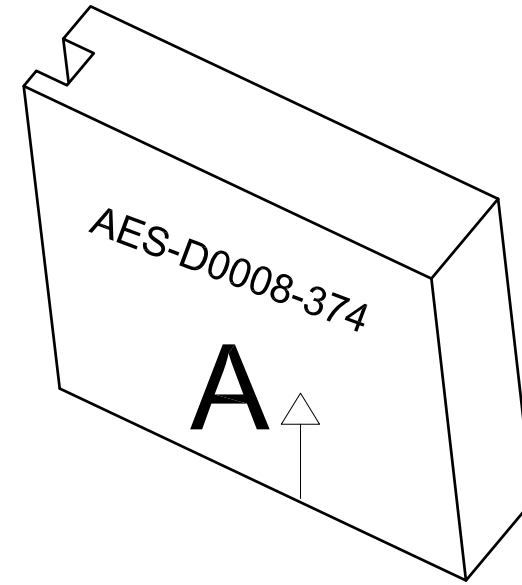

DRAWING NUMBER					AES-D0008				
SIZE	SCALE	SHEET	OF	REVISION					
A3	NONE	189	190	B					

— 376

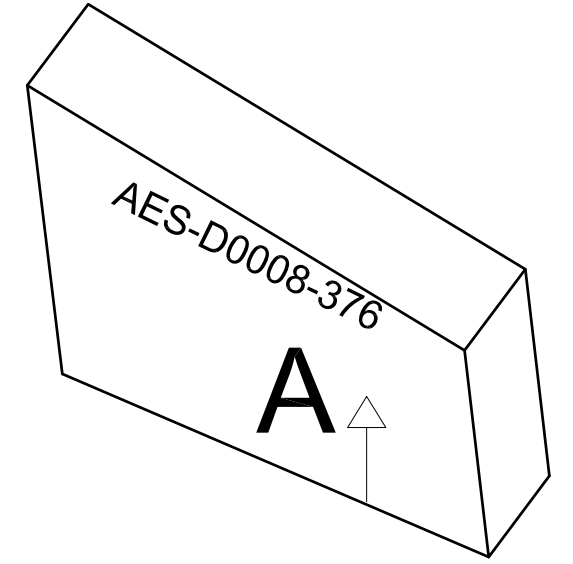
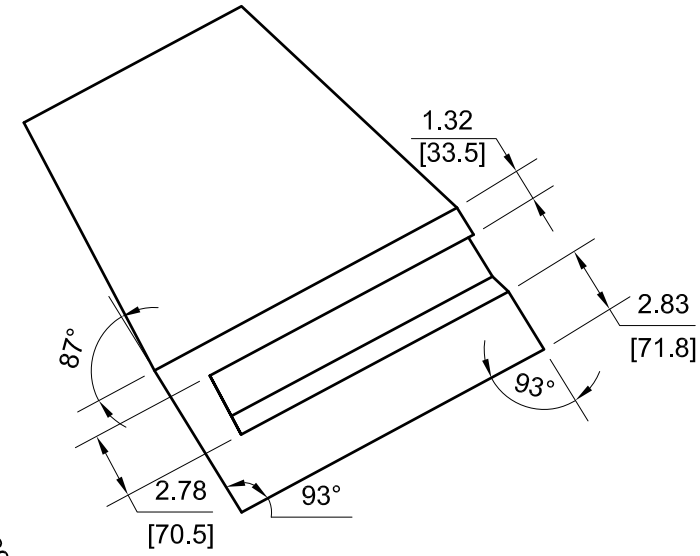
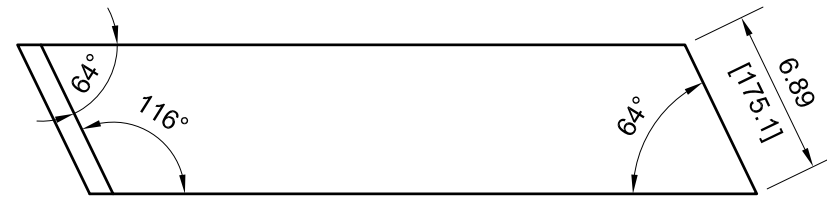

VIEW D5-190

C5-190 C6-190

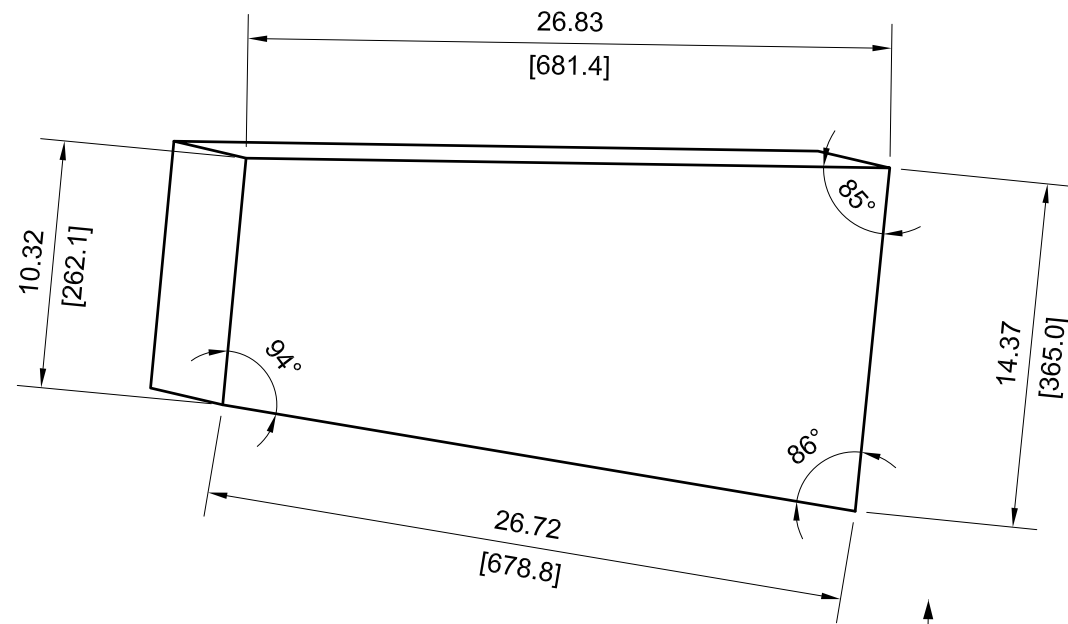

E5-190 F3-190



VIEW E5-190



DRAWING NUMBER				
AES-D0008				
SIZE	SCALE	SHEET	OF	REVISION
A3	NONE	190	190	B